

# Gain analysis of high-speed DWDM link with different optical amplification configurations

Rajan Miglani<sup>1</sup>, Gurjot Singh Gaba<sup>1,\*</sup>,  
Mehedi Masud<sup>2</sup> and Roobaea  
Alroobaea<sup>2</sup>

<sup>1</sup>Department of Electronics and  
Electrical Engineering, Lovely  
Professional University, Phagwara,  
144411, India.

<sup>2</sup>College of Computers and  
Information Technology,  
Taif University, Taif, 21974,  
Saudi Arabia.

\*E-mail: gurjot.17023@lpu.co.in

This paper was edited by  
Ashutosh Sharma.

Received for publication  
July 11, 2020.

## Abstract

Evolution of data-hungry devices has prompted the need for an exclusive communication infrastructure that can cater to the exponential increase in the need for high-speed data access. Since optical fiber links are inherently capable of supporting high-transmission data rates, fiber systems will be an integral part of the larger strategy to provide cost-effective high-speed data access to end users. This paper demonstrates the 100×40-Gbps dense wavelength division multiplexing (DWDM)-based 100-km-long fiber link whose performance has been analyzed using various configurations of a hybrid optical amplifier. The performance of the proposed link has been investigated using parameters like gain (dB) and bit error rate (BER). During the analysis, it has been observed that hybrid amplification, i.e., combination semiconductor optical amplifier (SOA), erbium-doped fiber amplifier (EDFA), and Raman amplifier, delivers overwhelming gain (dB) in comparison to the conventional stand-alone amplifier. Further, it has been seen that among different positional configurations of the amplifier, symmetrically positioned hybrid amplifiers achieved the gain of 18.6 dB, while the SOA link with similar configuration and parameters delivered link gain of merely -2.6 dB. In terms of BER performance, the symmetric hybrid configuration was outstanding with BER of 10<sup>-5</sup>, while preamplification link BER was merely 10<sup>-3</sup>, and post amplification being the most undesirable. The proposed link has been designed and investigated using OptiSystem™ 14.2.

## Keywords

Gain analysis, EDFA, hybrid amplifiers, positional configuration.

Rapid expansion of mobile services, tech-savvy lifestyle, e-commerce, and digital literacy are some of the key forces that have led to the creation of an enormous market for data service providers. However, fulfilling this ever-increasing data hunger will not be possible without incorporating communication technologies that can provide cost-effective high-speed data access to the end users. Radio infrastructure (RF) today forms the major backbone for data connectivity services, but it is highly likely that the current RF regime will witness massive performance-deficient systems in the near future (Miglani et al.,

2020b; Sharma and Sharma, 2016; Kumar et al., 2020). Lightwave communication links due to their large bandwidth and the ability to support high-speed data access will play a crucial role in the success of creating a digital world (Kumar et al., 2019). In order to utilize the bandwidth of the fiber more effectively and to make the transmission of multichannels possible, an efficient technique called wavelength division multiplexing (WDM) was introduced (Ivaniga et al., 2016; Chowdhury et al., 2019; Ji et al., 2019; Miglani et al., 2019). The transmitter section of WDM uses  $N:1$  multiplexer that combines incoming  $N$  optically

modulated channels to a single consolidated channel. Since all of these channels have different modulation wavelengths, the receiver section uses highly capable optical demultiplexers and filters to separate the participating wavelength signals (Sharma and Sharma, 2016; Miglani et al., 2020b). Among various forms of wavelength division multiplexing, the DWDM provides the best-in-class and efficient use of the available optical bandwidth (Sharma and Sharma, 2016). DWDM systems, therefore, allow tight packing of multiple information channels separated from each other by guard space to achieve a high-capacity optical network.

Signal transmission over long distances induces various forms of losses that include path loss, absorption loss, and scattering loss, to name a few. Such losses can play havoc with an estimated power budget, thus leading to deteriorated services (Curri and Carena, 2016). Therefore, it becomes imperative to use signal-conditioning measures that can strengthen the information-bearing signals for correct detection. There are a variety of optical amplification techniques and equipment available today, which can fulfill the aforementioned requirements. Semiconductor optical amplifier (SOA) is one such example that uses an optoelectronic mechanism to boost the incoming signals. SOA possesses design elements of an antireflection coating material at the end faces. These amplifiers are characteristically made from the compound semiconductors (typically from group III to group V). Although convenient and cost-effective to use, SOAs will find themselves incompatible with new-generation all-optical networks (Miglani et al., 2020a). Erbium-doped fiber amplifier (EDFA), on the other hand, uses an all-optical amplification process obtained through the action of an external pump source that generally operates either at 980 nm or 1480 nm. An important feature of EDFA is its ability to amplify signals in the C and L bands of the optical spectrum with low noise and cross talk as compared with SOA (Srinuan and Noppanakeepong, 2013; Pedro and Costa, 2018). EDFAs are, however, limited by the requirement of a high-powered external pump, low gains beyond C and L bands, and long length of EDFA required to achieve the desired gain. Raman amplifier also uses an external pump source to induce nonlinearity to achieve amplification. Using a high-powered external pump, stimulated Raman scattering (SRS) causes transfer of power from a pump to a modulated signal. Raman amplifier offers a very dynamic feature of tailoring-achievable gain over a wide range of wavelengths, and this is in sharp contrast to EDFA that has restricted operational bandwidth (Urquhart et al., 2007; Jose and Narayanan, 2015). Raman amplifiers are however

accompanied with high coupling losses and nonlinear amplification characteristics (Carena et al., 2001; Miglani et al., 2020b). Therefore, it can be decisively said that each of the amplifier mentioned here has its own set of advantages and limitations. Thus, it is for the same reason that hybrid amplifiers came into existence, and these amplifiers actually had all the favorable features of SOA, EDFA, and Raman amplifier. Such an arrangement of an amplifier has played a major role in achieving long-haul optical links with minimum signal conditioning at intermediate nodes.

Apart from designing and optimizing a hybrid amplifier, we have also investigated the performance of a proposed hybrid-amplified DWDM link for different positional configurations of the amplifier. There are possibly three different positional configurations in which the optical amplifiers can be in the photonic network, namely, pre, post, and symmetric. In pre-amplification configuration, the optical amplifier is positioned and operated right before the receiver, i.e., detection stage. This configuration is known to enhance receiver sensitivity and increased gain with the minimum addition of noise. Post-amplification configuration on the other hand allows the optical amplifier to be operated just after the transmitter section with an aim to strengthen the optical power that goes into the propagation medium. Last, symmetric-amplification configuration uses twin optical amplifiers, out of which one is used after the transmission, while the other operates before the data recovery section. Symmetric configuration delivers the best of pre- and post- amplification configuration, thus ensuring effective compensation of link losses (Carena et al., 2001; Urquhart et al., 2007; Pedro and Costa, 2018).

This paper consists of four sections. The second section examines the proposed methodology and simulation setup design features, while evaluation of the observed results has been put up in the third section. The paper is concluded with possible future scope of research in the fourth section.

## Proposed methodology and link design

In this paper, a high-speed DWDM optical link has been examined for performance analysis with different amplification configurations as shown in Figure 1A-C. Each of these links has been designed and investigated using a specialized design tool OptiSystem™. As mentioned previously, Figure 1A illustrates a DWDM link with post-amplification character, while Figure 1B, C highlights pre- and symmetric configurations, respectively. Irrespective of the amplification

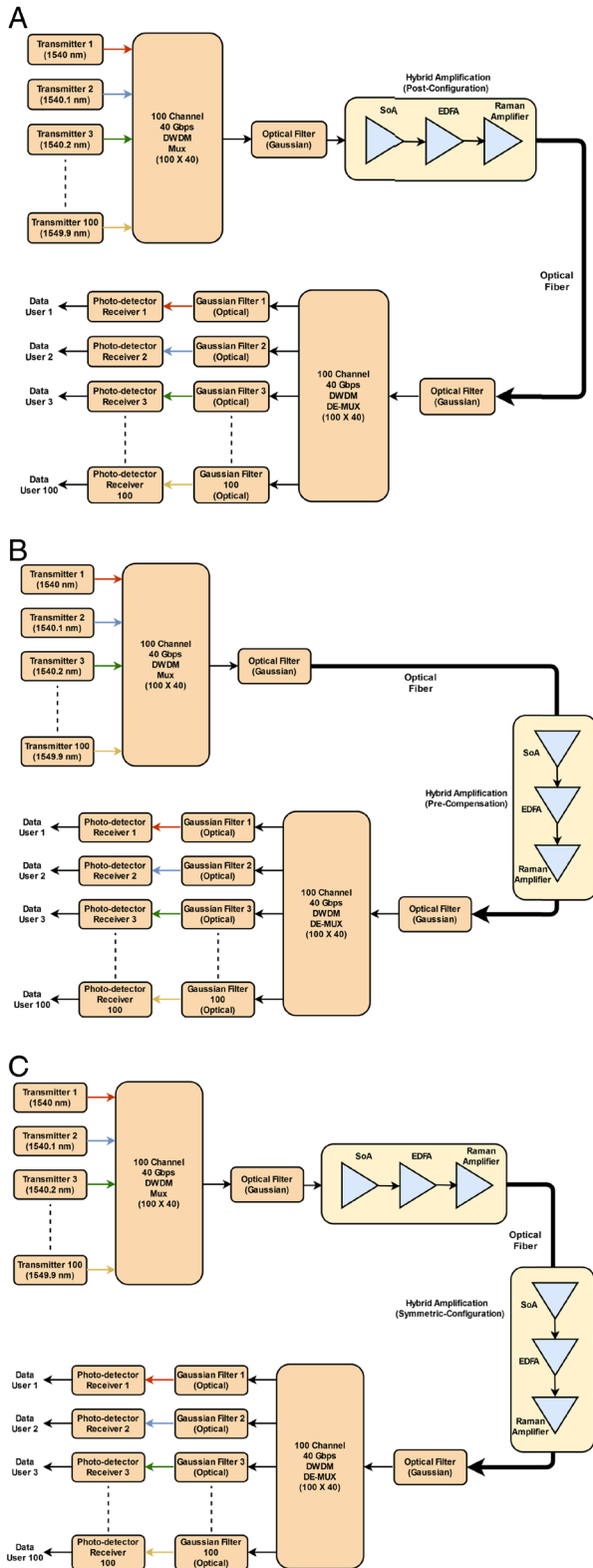

Figure 1: Proposed high-speed DWDM link with a hybrid amplifier positioned in (A) post-, (B) pre-, and (C) symmetric configuration.

configurations, each of these links can be said to have three fundamental segments, namely, transmitter, receiver, and amplifier. The transmitter section consists of 100 different optical sources that are capable of converting the user data (electrical) to an optical modulated signal. Each of these transmitters operates at a frequency (wavelength), which is different from the other. The wavelength spacing between the optical modulators is 0.1 nm, and all the transmitters operate on a fixed wavelength that lies in the channel band, i.e., 1,540 to 1549.9 nm. As a matter of fact, this channel lies within the conventional band (C band) of the third transmission window of optical communication. Further, each transmitter modulates and conditions the data at a rate of 40 Gbps, while the transmitted optical power from each of the channels can be varied from 0.1 to 1 mW, i.e.,  $-10$  to 0 dBm, respectively. Every transmitter shown in Figures 1 and 2 uses a Mach-Zehnder modulator to perform external modulation on nonreturn to zero (NRZ)-conditioned electrical signal with the help of a continuous-wave (CW) laser that acts as an optical carrier. Later, a 100:1 optical multiplexer combines all of the optically modulated 100 channels operating between 1,540 and 1,549.9 nm onto a single channel, such that each of the channel information remains intact through predefined channel spacing. This process of packing different channels through tight interchannel spacing is known as dense wavelength division multiplexing (DWDM). The second stage in each of our designs is that of amplification as explained in previous sections; we have chosen hybrid amplification over stand-alone options as the former is capable of delivering tailored benefits that otherwise cannot be achieved using SOA, EDFA, or Raman amplifier. In our case, the performance of the proposed link has been evaluated by placing the hybrid amplifier stage in pre-, post-, and symmetric configurations (Table 1).

After amplification, the signal is relayed over the medium, i.e., single-mode fiber (SMF). The third stage of our proposed design is that of the receiver section. In this section, the DWDM signal received over the propagating medium is optically filtered to remove out of band noise, thus permitting the channel, i.e., 1,540 to 1549.9 nm to pass through for further conditioning. Optical demultiplexer of the order of 1:100 is used to create 100 parallel outputs, such that each of the output nodes contains the same modulated information. Later on, a combination of 100 different optical modulators, each tuned to a specific wavelength as its pass band, allows retrieving the modulated information. This is followed by optical-electrical (O-E) conversion stage wherein

**Table 1. Transmitter design parameters.**

Parameter	Value/description
Transmission band	1,540-1,549.9 nm
Channel spacing	0.1 nm
Optical transmission power	0.1-1 mW
Optical modulation	External modulation (Mach-Zehnder modulator)
Data transmission rate	40 Gbps
Transmission medium	Single-mode fiber (SMF)
Total channels	100

photodetectors (PIN) are used to recover original data for each of the channels. A low-pass filter was also used in the proposed design after the O-E stage to further refine the message signal of noise ingredients (Table 2).

## Results and observations

In this section, we analyze the results obtained from the simulation setup presented in the previous section. The proposed link has been investigated for two different criteria, first, for different positional configuration of hybrid amplifier, and second, comparison of hybrid amplifier characteristics with those of the conventional choice, i.e., SOA. The results obtained from this

**Table 2. Amplifier and receiver design parameters.**

Parameter	Value/description
Injection current (SOA)	0.05 Amp
Length—EDFA	50 meters
Length—Raman amplifier	10 kms
Pump power—EDFA	300 mW (forward type)
Pump signal—wavelength	980 nm
Pump power—Raman amplifier	100 mW
Detector type	PIN
SMF attenuation (@1550 nm)	0.2 dB/km

analysis have been presented in the form of gain and BER analysis. The link behavior as observed from analysis of symmetric, post-, and pre-amplifier configurations using the SOA amplifier is compared with the result analysis of symmetric, post-, and pre-amplifier configurations using a hybrid amplifier for a 100-channel DWDM system. Figures 4 and 5 highlight the link gain (dB) pattern of the proposed 100-channel DWDM link with a hybrid amplifier and SOA, respectively, for the fiber length of 50 Kms. There are two distinct observations from Figures 4 and 5, first that symmetrical amplification is by far more effective than post- and pre-amplification, while least gain (dB) is observed for post-amplification configuration. Second, gain (dB) achieved in a symmetrical SOA configuration is way less as compared with a hybrid amplifier operated in similar conditions. Although the gain (dB) tends to decrease with an increase in transmission power, the highest gain for a hybrid amplifier is 18.6 dB as compared to -2.6 dB in the SOA-based DWDM link. Configuration comparison reveals that for a hybrid amplifier, gain varies from 18.6 to 9.3 dB for a symmetric configuration, 15.8 to 6.8 dB for pre-configuration, and 9.4 to 1 dB for post configuration, while as in the case of nonhybrid amplification (SOA), gain variations in the range from -2.6 to -3.7 dB for symmetric configuration, -4.7 to -4.9 dB for pre-configuration, and -4.8 to -5.6 dB for post configuration have been observed. From the aforementioned observations, we can assert that hybrid amplifier combination provides far better gain performance than the nonhybrid amplifiers. Refer Table 3 for a detailed comparison of the gain pattern in hybrid and nonhybrid amplifiers. An important observation from Table 3 is about the gain variation pattern of two amplifier types discussed here. While gain in a hybrid amplifier is way more than nonhybrid ones, the former witnesses major gain variation as transmission power increases, while the difference in maximum and minimum gain in the latter is drastically lower (Fig. 2).

Figure 4 demonstrates BER behavior of the proposed DWDM link for varying link range, i.e., fiber length. It has already been established from Figures 3 and 4 and Table 3 that a hybrid amplifier outperforms nonhybrid ones in terms of the quantum of the achieved link gain; hence, the BER analysis presented in Figure 4 has been restricted to a hybrid configuration only. It is observed here that with an increase in link length, the BER also tends to increase. As previously, the same trend is also seen here and symmetric configuration delivers highly reliable performance as compared to post- and pre-amplifier configurations. Furthermore, out of all the configurations, post-amplifier configuration is found to

Table 3. Gain (dB) comparison of hybrid and nonhybrid amplifier for different values of transmission power.

Transmission power	Hybrid amplifier			Nonhybrid amplifier		
	Pre-	Post-	Symmetric-	Pre-	Post-	Symmetric-
0.1 mW	15.8	9.4	18.6	-4.7	-4.8	-2.6
1 mW	6.8	1	9.3	-4.9	-5.6	-3.7

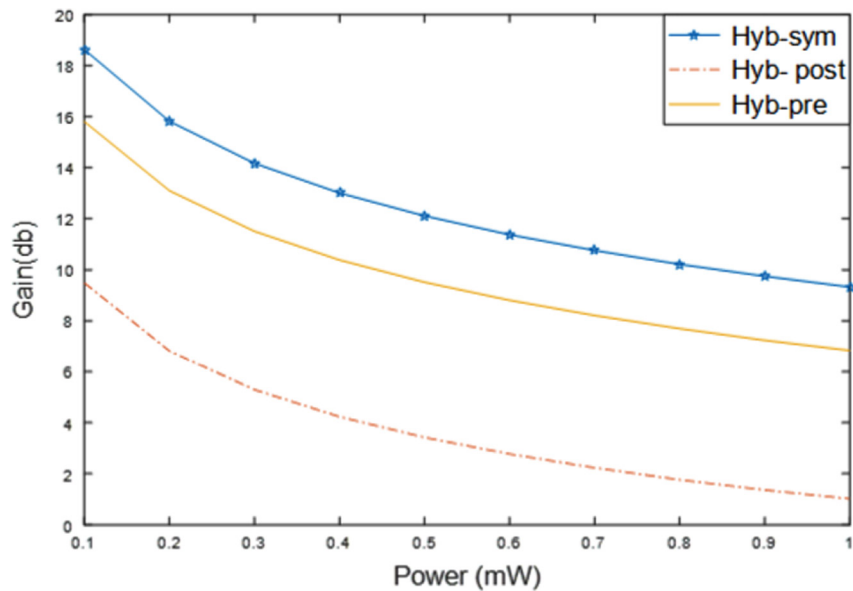

Figure 2: Analysis of power versus gain for symmetric, post-, and preamplifier configurations using a hybrid (SOA, EDFA, and Raman) amplifier.

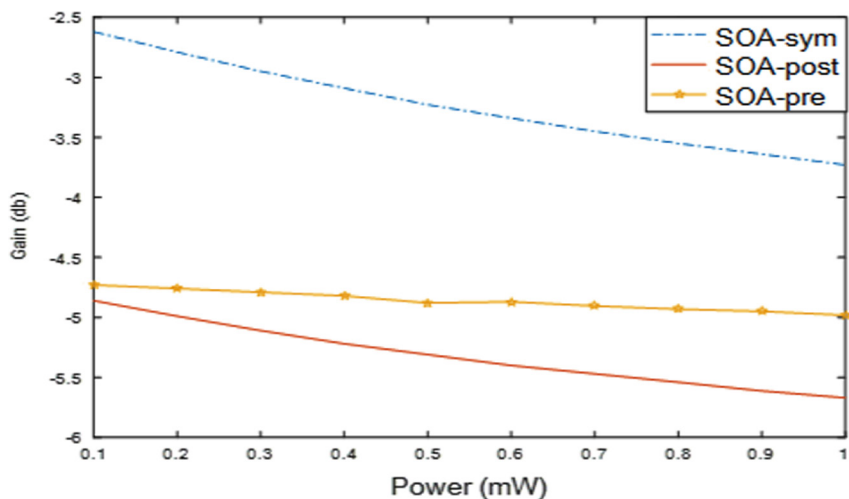

Figure 3: Analysis of power versus gain for symmetric, post-, and preamplifier configurations using SOA.

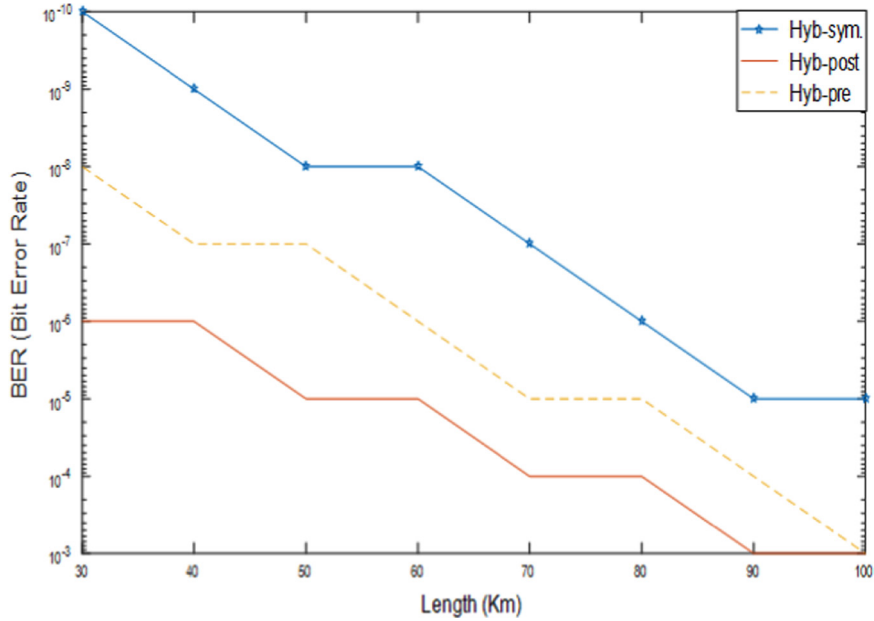

Figure 4: Analysis of BER and length using a hybrid amplifier for pre-, post-, and symmetric configurations.

have the maximum BER as compared to the others. From the analysis, it can be seen that at maximum possible link length, i.e., 100Kms, the symmetric hybrid amplifier-based DWDM link delivers decent BER of  $10^{-5}$ , compared to  $10^{-3}$  in post configuration. Detailed comparison of BER performances of the proposed link for different link ranges can be found in Table 4.

Figure 5 highlights the observations of gain (dB) variations across the spectrum of 100 information-bearing channels used in the proposed DWDM link with hybrid and nonhybrid amplifiers. It can be seen here that as we shift toward longer wavelengths of the transmitted band, increasing the wavelength,

the gain (dB) tends to increase and reaches the maximum of 18.3dB for a hybrid symmetric configuration. However, for hybrid pre- and post configurations, the gain (dB) patterns remain the same as in symmetric configuration, but then the quantum of gain increment decreases. Figure 5 also highlights that although the gain (dB) for a nonhybrid configuration is drastically lower than that of the hybrid link, the nonhybrid DWDM link witnesses a uniform gain across the channels. Ideally, it will be desired to have a uniform gain (dB) across all channels to ensure that cross-channel cross talk and saturation effects are minimized; hence, based on this criterion, Table 5 elaborates gain variations across the channel for a hybrid-amplified link. It is therefore evident from Tables 4 and 5 that although symmetric configuration delivers best-in-class BER performance, but when it comes to uniformity of gain across all channels, preconfiguration is the ideal candidate for long-haul networks because of its lowest gain (dB) variations across the high-speed channels.

**Table 4. BER comparison at different link range (kms).**

Configuration	Link range		
	50 km	70 km	100 km
Pre-	$10^{-7}$	$10^{-5}$	$10^{-3}$
Post-	$10^{-5}$	$10^{-4}$	$10^{-2}$
Symmetric-	$10^{-8}$	$10^{-7}$	$10^{-5}$

### Conclusions

We have investigated the performance of a 100-channel DWDM system using a nonhybrid (SOA) and hybrid amplifier in symmetric, post-, and preconfigurations. Improved performance in terms

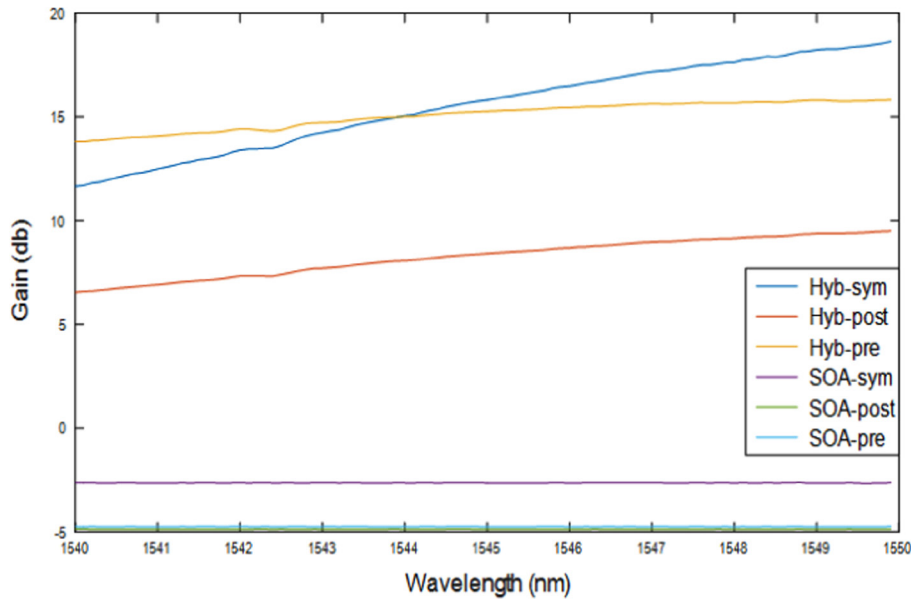

Figure 5: Analysis of wavelength versus gain for hybrid and SOA in symmetric, pre-, and post-amplifier configurations.

**Table 5. Gain (dB) variations of hybrid-amplified DWDM link.**

Configuration	Gain (dB) maximum	Gain (dB) minimum	Difference (dB)
Pre-	15.7	14.4	1.3
Post-	9.8	6.9	2.9
Symmetric-	18.3	11.8	6.5

of link gain (dB) and BER has been observed in hybrid amplifier-aided links compared to nonhybrid counterparts. Moreover, out of all three configurations, pre-, post-, and symmetric configurations considered here, the symmetric amplifier arrangement witnesses higher gain (dB) and reduced BER as compared to other amplifier configurations. However, when it comes to channel gain variations, preamplifier configurations are found to be most suited for long-haul applications.

## Literature Cited

Carena, A., Curri, V. and Poggiolini, P. 2001. On the optimization of hybrid Raman/erbium-doped fiber amplifiers. *IEEE Photonics Technology Letters* 13(11): 1170–1172.

Chowdhury, M. Z., Hasan, M. K., Shahjalal, M., Shin, E. B. and Jang, Y. M. 2019. Opportunities of optical spectrum for future wireless communications. 2019 International Conference on Artificial Intelligence in Information and Communication (ICAIIIC), Okinawa, 004–007, doi: 10.1109/ICAIIIC.2019.8668981.

Curri, V. and Carena, A. 2016. Merit of Raman pumping in uniform and uncompensated links supporting NyWDM transmission. *Journal of Lightwave Technology* 34(2): 554–565.

Ivaniga, T., Ovseník, L. and Turán, J. 2016. The four-channel WDM system using semiconductor optical amplifier. 26th International Conference Radioelektronika (RADIOELEKTRONIKA), Kosice, 354–357.

Ji, Y., Zhang, J., Xiao, Y. and Liu, Z. 2019. 5G flexible optical transport networks with large-capacity, low-latency and high-efficiency. *China Communications* 16(5): 19–32.

Jose, T. and Narayanan, V. 2015. Design of a gain flattened doped fiber amplifier with stabilized power

output for WDM transmissions. 2015 International Conference on Microwave, Optical and Communication Engineering (ICMOCE), Bhubaneswar, 193–196.

Kumar, D., Sharma, A., Kumar, R. and Sharma, N. 2019. Restoration of the network for next generation (5G) optical communication network. In 2019 International Conference on Signal Processing and Communication (ICSC), IEEE, pp. 64–68.

Kumar, D., Sharma, A., Kumar, R. and Sharma, N. 2020. A holistic survey on disaster and disruption in optical communication network. *Recent Advances in Electrical & Electronic Engineering (Formerly Recent Patents on Electrical & Electronic Engineering)*, 13(2): 130–135.

Miglani, R., Malhotra, J. S. and Gaba, G. S. 2019. Gain performance analysis of optical parametric amplifiers employing different modulation techniques. *Journal of Optics* 48: 155–159, available at: <https://doi.org/10.1007/s12596-018-0502-x>.

Miglani, R., Malhotra, J. S., Majumdar, A. K., Tubbal, F. and Raad, R. 2020a. Multi-hop relay based free space optical communication link for delivering medical services in remote areas. *IEEE Photonics Journal*, 12(4): 1–21, doi: 10.1109/JPHOT.2020.3013525.

Miglani, R., Singh, G., Singh, G., et al. 2020b. “Gain optimization of 100×40 Gbps high capacity DWDM fiber optical link using hybrid amplification techniques”, *Journal of Optics* 49(3): 323–331.

Pedro, J. and Costa, N. 2018. Optimized hybrid Raman/EDFA amplifier placement for DWDM mesh networks. *Journal of Lightwave Technology* 36(9): 1552–1561, doi: 10.1109/JLT.2017.2783678.

Sharma, S. R. and Sharma, V. R. 2016. Gain flattening of EDFA using hybrid EDFA/RFA with reduced channel spacing. 3rd International Conference on Signal Processing and Integrated Networks (SPIN), Noida, 260–264.

Srinuan, C. and Noppanakeepong, S. 2013. The analysis of shift alternative repeated unequally spaced channels allocation for DWDM system. *International Journal of Information and Electronics Engineering* 3(6): 594–598.

Urquhart, P., Lopez, O. G., Boyen, G. and Bruckmann, A. 2007. “Optical Amplifiers for Telecommunications”, 2007 IEEE International Symposium on Intelligent Signal Processing, Alcalá de Henares, October 3–5, pp. 1–6, doi: 10.1109/WISP.2007.4447524.