

# Archaeological Atlas of the 2 Seas

**A Cross-border  
Maritime Archaeology Project**

**Final Report | 2009-2012**



# A2S Project Supporters



## A project that goes beyond borders

Archaeological dive on the iron ingots site in the Triagoz (FR).  
© T. Seguin/ADRAMAR/A2S

The Archaeological Atlas of the 2 Seas (A2S) is a cross-border archaeological project that has involved archaeologists from France, England, Belgium and the Netherlands as project partners or members of the steering committee. The *Association for the Development of Maritime Archaeological Research* (ADRAMAR) in France, *Flanders Heritage Agency* (Onroerend Erfgoed) in Belgium and the *Hampshire and Wight Trust for Maritime Archaeology* (HWTMA) in England conducted the A2S project, supported by national heritage agencies such as the *Department of Underwater Archaeological Research and Sub-Marines* (DRASSM) and *English Heritage*.

From 2009 to 2012, the partners have studied over 150 submerged archaeological sites, collecting data from primary literary sources and national archives. The findings steered a programme of field investigation exploring almost 100,000 years of our collective submerged cultural heritage from prehistoric landscapes to present day shipwrecks.

The collated information has been synthesised to feed the national inventories of archaeological sites and the partners' databases. These, in turn, can be found online via the A2S Geoportal through an interactive geographical web interface making the common underwater cultural heritage accessible to anyone for years to come.

The international scope of the project has appealed to schools. This led to the development of tri-lingual teaching resources from each

partner country. The focus was a shipwreck with a common connection between the nations who communicated via the internet and by visits from a purpose built maritime archaeological bus.

A key objective of the project was to maximise engagement with a broad audience by disseminating the results as widely as possible. Accordingly the team has reached into the community of volunteers and professional archaeologists for support and collaboration while the project has been encapsulated in a broadcast quality film.

*“The collated information has been synthesised to feed the national inventories of archaeological sites and the partners' databases.”*

By the end of the A2S project a strong network of co-workers was developed; the direct training and building of experience to hundreds of participants had taken place; thousands of individuals had been directly involved and strong links were established between nations. We believe the foundations are now laid for future projects that will facilitate further European collaboration around some of the richest cultural resources on the globe. ■

*Alexandre Poudret-Barré, Garry Momber, Ine Demerre & Inge Zeebroek*

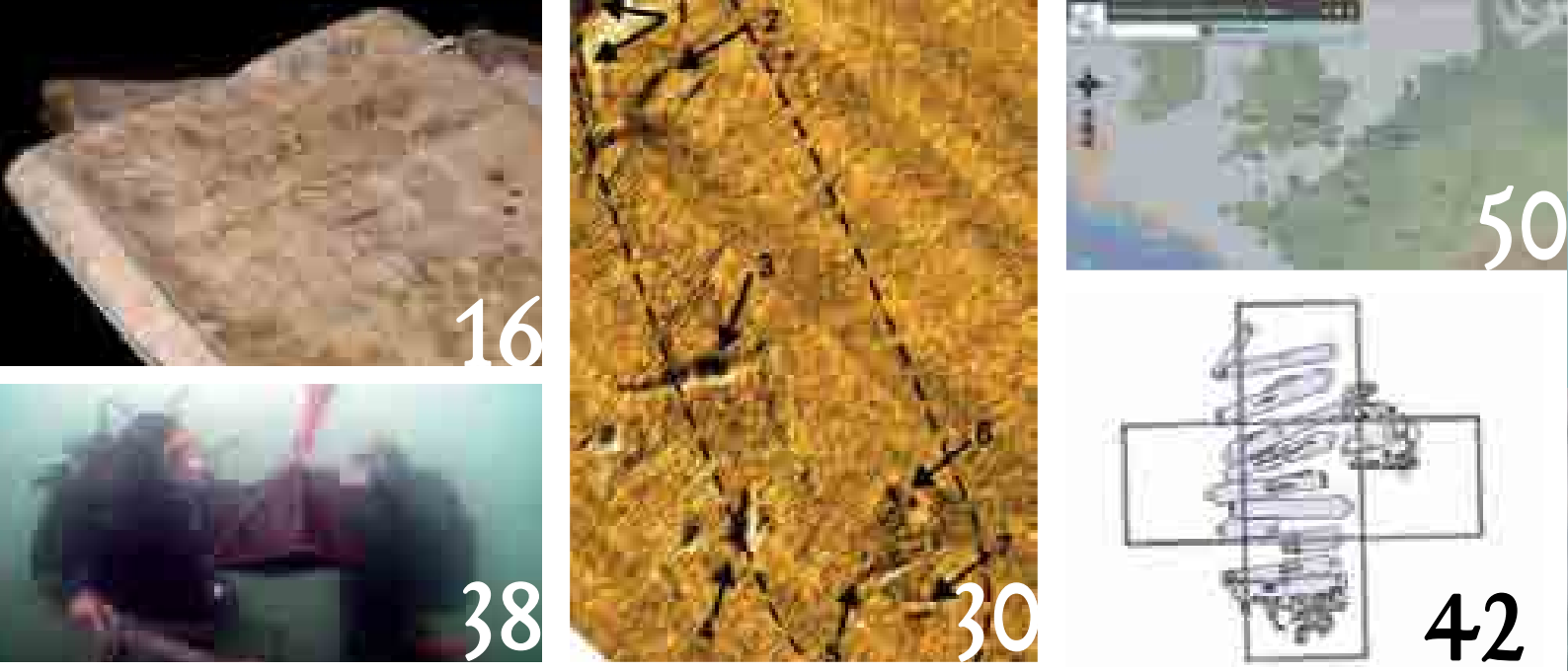

# A2S project objectives to

- build an international archaeological team
- establish a cross-border collaboration between the partners
- share knowledge and data about underwater archaeological sites
- create a publicly accessible geoportal about the underwater cultural heritage of the 2 seas
- survey underwater archaeological sites to enhance understanding of our submerged cultural heritage
- promote our common underwater cultural heritage through education and outreach
- share experience and best practice in archaeological techniques
- assist students and volunteers in gaining practical experience of underwater archaeological methods

Towed deployment of magnetometer during survey.  
© T. Seguin/ADRAMAR/A2S

## Table of contents

A2S project	5
A2S project objectives	5
A2S project	7
A2S scientific partners	8
A2S steering committee members	10
External project participants and co-workers	12
INTERREG IV A 2 Seas	14
Management	15
The activities	16
Desk-based research	16
Archaeological survey	18
Case studies	20
Archaeological research	22
Geophysical survey off the French coast	26
't Vliegende Hart	30
The site of Raversijde beach	32
Biéroc-la-Mondrée	36
Mesolithic industry below the Solent shores	38
Shipwreck research and investigation	40
Excavation of the ZI 24 shipwreck	42
HMS Wakeful	44
Flower of Ugie	46



A2S dissemination	48
A2S Geoportal	50
The French experience	54
Education and outreach	56
The SS Londonier	60
Communication	66
Project experience	72
Acknowledgements	74
Contacts	78
A2S documentary DVD	79

*“Somewhere on the seabed of the Channel and the North Sea there remain a large number of archaeological sites. These are all witnesses to a vast and forgotten history.”*

Michel L'Hour, Director of the Drassm

# A2S project



↑ A2S team briefing during a survey off the coast of Morbihan (FR). © T. Seguin/ADRAMAR/A2S

*Archaeological Atlas of the 2 Seas (A2S)* is an ambitious project to collate cross-border archaeological maritime heritage data. It is being delivered by ADRAMAR, HWTMA and Onroerend Erfgoed/Flanders Heritage (Onroerend Erfgoed) and is co-funded by the European Union. The project is supported by three of the main underwater archaeological research and management groups in Europe: DRASSM in France, Flanders Heritage in Belgium and English Heritage in the UK.

**T**he overall aim of the four-year project has been to map underwater archaeological sites in the shared seas of France, England and Belgium.

Sharing both the English Channel and the southern North Sea, these three coastal states have a common heritage drawn from a shared maritime history.

Europe's foundations rest on wars, trade and alliances. While shipwrecks bear testimony to our often shaky allegiances, underwater archaeological landscapes illustrate our history dating back many thousands of years. This geographical area forms a tangible link between the countries of northern Europe, constituting a common cultural heritage.

However to date, despite this shared history, the treatment of both documentary and archaeological data is still essentially based at the national or even local level. A2S was born from this lack of exchange. Its aim is to combine the knowledge and information related to the underwater archaeology in our shared seas so that each country has access to all possible information, not just that from its own national resources.

For example, research related to an English ship wrecked in French or Belgian waters is

often not extended to British archives. This is a frustrating situation for researchers and it is these sorts of limitations that this international project aims to resolve.

A new approach to understanding our shared maritime history is now under way using the combined skills of French, English and Belgian archaeologists.

For several years these three countries have collected and mapped data on archaeological sites in their own seas.

One of the first stages of the A2S project is to link the partners' databases via a Geoportal which will comprehensively link the underwater landscape. This information will be added to in the years to come and will include the location of known shipwrecks and other underwater archaeological sites. It is aimed not only at students, researchers and the general public, but also at heritage management groups in the partner countries.

Alongside this research and data compilation, archaeological teams from the three partners have been deployed to conduct geophysical and archaeological

surveys in each of the partner countries. Some of the shipwrecks that have been chosen for study have great significance in terms of shared heritage between the member countries. One such vessel, *SS Meknès*, was a French ship repatriating troops to France in July 1940 after the Franco-German Armistice. Despite the treaty a German E-boat torpedoed the vessel. It now lies in English waters.

“*A new approach to understanding our shared maritime history is now under way using the combined skills of French, English and Belgian archaeologists.*”

As the project has drawn to a close the international team has made a wealth of information available for access via the Geoportal. This can now be used for a broad range of research topics. These could range from the study of ancient trade routes and comparative studies on naval architecture, to the evolution of nautical weaponry and even the study of the possessions that characterised the daily lives of mariners. ■

Cargo cannon on the Chariot shipwreck lost in April 1676 (FR). © T. Seguin/ADRAMAR/A2S





## A2S Team

### From bottom to top and left to right

- Caroline BARRIE-SMITH, Education Officer (UK)
- Victoria MILLERSHIP, Administrator & Project Officer, Maritime Archaeologist (UK)
- Jan GILLESPIE, Maritime Archaeologist (UK)
- Virginia DELLINO-MUSGRAVE, Project Manager, Maritime Archaeologist (UK)
- Stephen FISHER, Maritime Historian (UK)
- Charlotte GEORGEAULT, Financial Manager (FR)
- Garry MOMBER, Director, Maritime Archaeologist (UK)
- Yann GAONAC'H, Historian (FR)
- Inge ZEEBROEK, Project Coordinator, Maritime Heritage Researcher (BE)
- Lauren TIDBURY, Maritime Archaeologist (UK)
- Ine DEMERRE, Project Coordinator, Maritime Heritage Researcher (BE)
- Cheryl WHITEHEAD, Administrator (UK)
- Gareth OWEN, Education Officer (UK)
- Brandon MASON, Maritime Archaeologist (UK)
- Anne HOYAU-BERRY, Maritime Archaeologist (FR)
- Charlotte LE NOAC'H, Archaeologist (FR)
- Cécile CHATELIN, Communication Manager (FR)
- Christin HEAMAGI, Maritime Archaeologist (UK)
- Django GUYON, Archaeologist (FR)
- Alexandre POUDRET-BARRÉ, Projects Manager, Maritime Archaeologist (FR)
- Pieterjan DECKERS, Communication Officer (BE)
- Victor LAFORÉT, Survey Technician (FR)
- Georges LE PELLETIER, Boat Mechanic (FR)
- Erwan MARION, Maritime Archaeologist (FR)
- Sven VAN HAELST, Maritime Heritage Researcher (BE)
- Valentine VERRIJKEN, Maritime Heritage Researcher (BE)
- Julian WHITEWRIGHT, Maritime Archaeologist (UK)

### Out of picture:

- Jessica BERRY, Maritime Archaeologist (FR)
- Amanda BOWENS, Education & Outreach Manager (UK)

## A2S scientific partners



**The Association for the Development of Maritime Archaeological Research (ADRAMAR)** was formed in 1993 by professional archaeologists in order to promote research into maritime archaeology both in France and internationally.

It has participated in some high profile excavations : the wrecks of *La Natière* (St Malo, 18<sup>th</sup> century), the *Brunei junk* (Borneo, 16<sup>th</sup> century), the *Lapérouse expedition* (Solomon Islands, 1788).

ADRAMAR's mandate brings together the following:

- study and protection of archaeological sites;
- assistance and training in underwater archaeological excavations;
- scientific meetings, conferences and exhibitions;
- publication of monographs and archaeological guides;
- consultation with public bodies, groups and associations;
- public awareness of marine archaeology.

ADRAMAR works together with the DRASSM, part of the French Ministry of Culture and Communication responsible for managing, protecting and studying French maritime heritage at home and overseas.

Since 2005 ADRAMAR has been leading the project *Atlas archéologique des biens culturels maritimes de l'Arc atlantique*, thanks to the financial support of local government. This project is helping to demonstrate the value of submerged archaeological sites off the west coast of France. It largely inspired the A2S programme of which ADRAMAR is the project leader.



**The Hampshire and Wight Trust for Maritime Archaeology (HWTMA)** was founded to promote interest, research and knowledge of maritime archaeology and heritage in the UK. This includes archaeological research and education and outreach activities on a local, national and international scale.

The HWTMA's objectives include :

- maritime archaeological research and investigation;
- preservation and management of archaeological sites;
- public awareness, enjoyment and participation;
- archaeological awareness and competence amongst divers;
- development of a maritime archaeological database of sites;
- publication of investigations and research;
- liaison with local, regional and national heritage organisations.

To fulfil these objectives the HWTMA runs a programme of research-led fieldwork with professional archaeologists, volunteers and students. Shipwrecks, submerged landscapes and inter-tidal sites are investigated and reported through publications, lectures and educational initiatives including resources for schools and educators and outreach events.

The HWTMA's goals correspond with the aim of the A2S project of facilitating fully-integrated European co-operation in the investigation of internationally significant wrecks and submerged landscapes. The HWTMA believes that trans-national links are vital to enable full analysis and dissemination of our common heritage.



**Flanders Heritage Agency (Agentschap Onroerend Erfgoed)** is part of the Flemish government. Driven by a passion for heritage, our officers protect and manage inventories

of valuable buildings, landscapes and archaeological sites. Furthermore, we provide a stimulating environment for heritage management and conduct research supporting government policy regarding heritage. *Flanders Heritage* is a national and international centre of expertise and information. In order to disseminate this information, we maintain several significant heritage inventories, including a database for maritime heritage (publicly accessible at [www.maritime-archaeology.be](http://www.maritime-archaeology.be)). Research results are published through diverse media, including an Open Archive website (<http://oar.onroenderfgoed.be>), journals like *Relicta* and *M&L*, various other academic and popular publications, exhibitions and conferences.

Since 2003, maritime archaeologists at *Flanders Heritage* have actively worked on the inventory and research of archaeological sites in underwater and intertidal environments. Sites above and below water are investigated through on-site fieldwork, but also through the application of state-of-the-art geophysical and remote sensing techniques. Furthermore, existing collections kept by local museums, fishermen and sport divers are studied. For these purposes, the agency cooperates with various scientific and other partners in Flanders and abroad, including the *Flanders Marine Institute* (VLIZ), the province of *West-Flanders* and several universities.

*Flanders Heritage* is the youngest partner of the A2S-project. Through its participation in the project, the Agency's maritime archaeologists and numerous volunteers have enhanced their knowledge of new techniques and current standard practices in the study of maritime heritage.

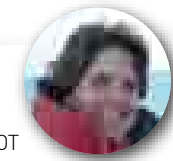

Olivia HULOT  
Project Officer  
Maritime Archaeologist

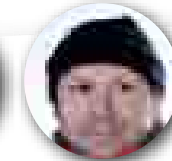

Denis DÉGEZ  
Project Officer  
Maritime Archaeologist

### Involvement of the DRASSM in the A2S project:

The *Department of Underwater Archaeological Research* (DRASSM), has a national responsibility for the protection and management of France's submerged cultural heritage. The DRASSM is a key partner in the A2S project. It provides expertise through the delegation of two staff members and supports the project financially. The staff members are Olivia Hulot, responsible for the Atlantic, English Channel and North Sea coasts of France and Denis Degez, project officer. Both lend their knowledge and expertise to project activities.

In 2005, the DRASSM initiated a precursor project on the west coast of France, called the *Atlas archéologique des biens culturels maritimes de l'Arc atlantique*. This is a GIS based register of underwater archaeological sites, supported by a substantial number of researchers, professionals and volunteers working within a common framework. In 2008 and 2009 this was followed by similar projects undertaken for the coasts of Provence and Languedoc.



© For both portraits T. Seguin/ADRAMAR/A2S

# A2S Steering Committee members

## What is the Steering Committee?

The Steering Committee is made up of internationally renowned experts in the field of maritime archaeology. The A2S project team convened the Committee so they could provide advice and direction as the project developed. The extensive experience of the members enabled them to take a holistic view while steering the work in a direction that would take international collaboration beyond the time-frame of the project.

During the four years of the project, three Steering Committee meetings have been held; in Brussels (December 2010), Southampton (December 2011) and Rennes (June 2012).

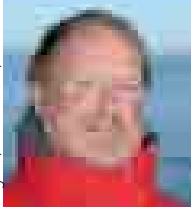

**Director of the DRASSM**  
147 plage de l'Estaque  
13016 Marseille  
France

**Michel L'Hour**

*“The fundamental purpose of the project was to collect data which was disseminated in the various countries; to get English, Belgian and French divers to work together and beyond this, to eventually establish a huge atlas of the wrecks, and also to manage common exploration and survey programmes. We have made huge progress. I think that we are standing even beyond what we had imagined, this is a real success.”*

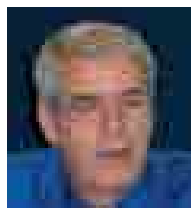

**Heritage Protection Director  
English Heritage**  
1 Waterhouse Square  
138-142 Holborn  
London EC1N 2ST  
England

**Adrian Olivier**

*“A great success of the A2S project has been achieved by the partners working together with common objectives while retaining their diversity. The project provides a useful framework within a coherent structure where valuable work can take place. The ability of the partners to work separately and together exchanging information, and building on specialist expertise is a model that should be commended.”*



**Research director  
LAMOP (University of Paris 1/CNRS)**  
Musée national de la Marine  
Palais de Chaillot  
17 place du Trocadero  
75 116 Paris [France]

**Eric Rieth**

*“The Archaeological Atlas of the 2 Seas is a very original programme. Firstly because it covers a submarine archaeological heritage running from prehistoric times to the present, and it is specifically representative of the French Ponant and the British and Flemish coasts, but also because it represents a common European marine archaeological memory. The Atlas is also outstanding in its very design, presenting high level scientific contents in a format highly accessible, not just to the community of researchers, but to anyone with a passion for submarine archaeology, history and our common marine heritage.”*



**Professor  
Department of Archaeology University of York**  
The King's Manor  
York YO1 7EP  
England

**Geoff Bailey**

*“The partnership is a great success. The cross-border cooperation is leading to enthusiastic participation in collaborative work and the sharing of good practice, and is an excellent demonstration of international European teamwork. The education and outreach is fabulous. It demonstrates the wider impact of the research and the significance of maritime archaeology to a wider public.”*



**Director of International Activities  
Flanders Heritage Agency**  
Albert II-laan 19, bus 5  
B-1210 Brussel  
Belgium

**Marnix Pieters**

*“The Archaeological Atlas of the 2 Seas project demonstrated in a very convincing way that the underwater heritage deserves an international approach.”*

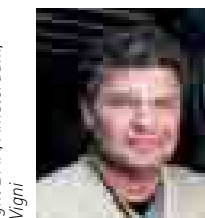

**Head of the Archaeological Division,  
City of Amsterdam  
Professor University of Amsterdam**  
Herengracht 482  
Postbus 10718  
1001 ES Amsterdam [Netherlands]

**Jerzy Gawronski**

*“The A2S project combines in an unique international cooperation the digital mapping of maritime archaeological sites with a programme of underwater fieldwork operations and public outreach education. A2S is a successful example of a practical and innovative approach in European maritime heritage policy which deserves to be further developed.”*

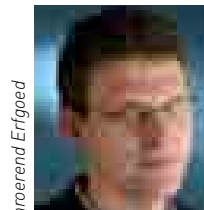

**Head of Heritage Listing  
and Protection  
Flanders Heritage Agency**  
Albert II-laan 19, bus 5  
B-1210 Brussel  
Belgium

**Marc De Bie**

*“Leaning on the shoulders of our knowledgeable neighbours, the Atlas project intensively fuelled our incipient expertise in maritime archaeology. My only hope is that the injection will be sustainable and will eventually anchor a tradition of concern for our maritime archaeological heritage.”*

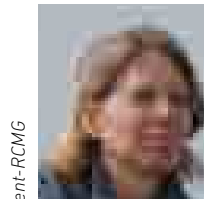

**Senior researcher at RCMG  
Ghent University**  
Krijgslaan 281 - S8  
B-9000 Ghent  
Belgium

**Tine Missiaen**

*“The intense collaboration within the A2S project has played a key role in its success. I was particularly impressed by the outreach and education, which allowed school children to discover the world of marine archaeology.”*



# External project participants and co-workers

There were many project participants who helped make the project a great success. The broad spectrum of help provided by volunteers and professionals was greatly appreciated and cannot be overstated. Roles and activities are outlined in the sections below, but the page remains too small to include the names of individuals or organisations. These have been given their own space on pages 74-77.

## In England

The submerged cultural heritage belongs to all humanity as it tells the story of our common past. Its study is multi-disciplinary and as such necessitates input from a wide range of people. Accordingly, participants in the A2S project from the UK have been many and varied.

Volunteers from the south coast have conducted research into local archives and spent many hours filling databases with the results. Avocational divers from the UK with archaeological skills have helped record and excavate shipwrecks in all three partner nations. They have not only conducted high quality fieldwork but have provided skilled input including underwater photography, video and boat handling. This is in addition to providing their own resources and equipment.

The success of the project has also relied on commercial expertise. This has come from highly proficient boat skippers who ensured we would be placed on shipwrecks every time, or from geophysical companies who enabled the collection of side-scan sonar data over sites of greatest interest. The production of a broadcast-quality footage is another area where we called on specialists to film below water and above.

Finally, the involvement of schools should receive attention. Because archaeology and maritime heritage are not national curriculum

subjects in any of the partner countries, in-school work is only possible with the pro-active support and collaboration of teachers and staff over and above their normal activities.. The 3-nation schools programme (see page 64), for example, was made possible thanks to the wholehearted participation of teachers working within each of the partner schools. This enabled children to participate enthusiastically within and between partner country schools while taking part in the A2S programme of activities. Appreciating the past makes us familiar with the present, while understanding our common heritage can set foundations for a collective future. The education of our children is key to this.

*French volunteers dived with the English team on the Wight Spirit in the Solent (UK).  
© A. Hoyau-Berry/ADRAMAR/A2S*



## In France

The development of underwater archaeology in France owes much to the work of volunteer divers who are archaeology and history enthusiasts. For several decades, they have been active in the archive rooms and in the field, thereby improving our knowledge of marine history.

By sharing their findings and participating in our efforts towards the enhancement of the marine heritage, they have become helpful contributors to the A2S project, especially as they integrated their own, often unpublished, data into the French database.

Some of these highly committed collaborators also became involved in A2S project fieldwork operations. Gilles Drogue and Joë Guesnon, for example, took part in the survey of the site at

Biéroc-la-Mondrée and they later worked on the English site of Bouldnor Cliff, sharing their experiences and exchanging their practice with English and Belgian archaeologists. No doubt this first contact will become a long-term relationship. Successful institutional collaborations were also established as part of the A2S programme. The survey of the Biéroc-la-Mondrée site, a partnership with the Basse-Normandie Regional archaeological service (*Service Régional de l'Archéologie Basse-Normandie*) made a connection between terrestrial archaeology and marine archaeology, bridging the gap behind and between the two disciplines. This helped promote research programmes through the extra European visibility achieved by the mapping interface of the A2S, as shown by the successful integration of the fish traps surveyed by AMARAI and CReAAH (UMR 6566).

## In Belgium

The maritime archaeologists of Flanders Heritage Agency would not have been able to produce so many results within such a short time without the generous support and cooperation of several scientific institutions, other organizations and individuals.

For long Flanders Heritage has been working closely together with the province of West Flanders. For the A2S project they provided various outlets for the dissemination of research results to the public including exhibitions, symposia and support for the development of the national maritime database [www.maritime-archaeology.be](http://www.maritime-archaeology.be). The Flanders Marine Institute (VLIZ), which coordinates marine scientific research in Flanders, made available archival data and contacts, a public platform as well as web hosting for the maritime database. But crucially for the A2S survey campaigns was the provision of the research vessel 'Zeeleeuw'.

The first step towards archaeological investigation of the project targets in Belgian waters was based on the invaluable archives and important assistance during subsequent research of Flemish Hydrography (The Agency for Maritime and Coastal Service, Dept. of Coast). Other archival evidence has been made available through many different channels, from official institutions to private collectors and divers.

Several research divisions at Ghent University contributed to the geophysical research, notably RCMG (Dept. of Geology and Soil Sciences) and ORBit (Dept. of Soil Management).

But the on-site investigation of the wreck sites would not have been possible without our dedicated and enthusiastic team of students and no less than 34 experienced North Sea divers who volunteered to learn but also to reveal more information about this precious heritage.



*↑ Belgian volunteers exchanging their survey results after the dive (BE). © A. Hoyau-Berry/ADRAMAR/A2S*

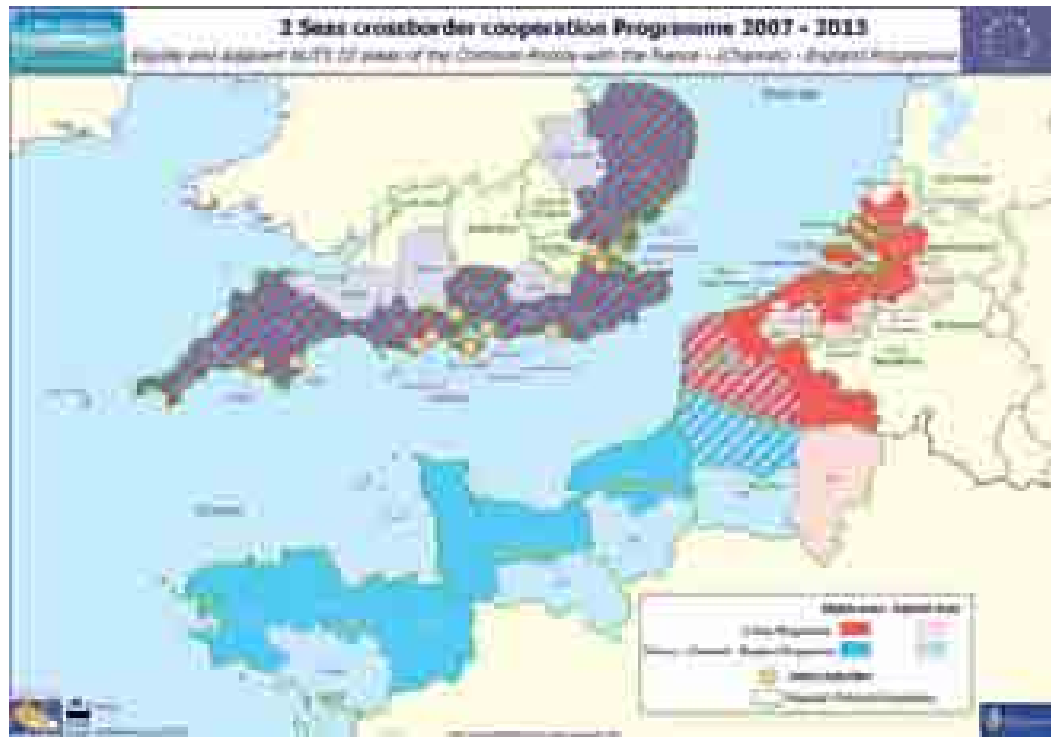

The INTERREG IV A 2 Seas Programme enables crossborder cooperation of local and regional actors from different territories of four member states of the EU: England, Belgium (Flanders), France and the Netherlands.

# INTERREG IV A 2 Seas

## invests in your future

**T**he purpose of this programme is to generate positive results and solve issues of common interest in situations where this would not have been possible through a strictly national approach.

The programme is based around the three key priorities of economic development, protection of the environment and improvement of quality of life. It shares a common priority with the France (Channel)- England INTERREG IV A Programme.

The 2 Seas Crossborder Cooperation Programme is part-financed by the European Union (ERDF) with 167 million euros available for the 2007-2013 programming period. ■

### More information and contact details:

Joint Technical Secretariat - INTERREG IV A 2 Mers Seas Zeeën  
Les Arcuriales, 45/D rue de Tournai, 5<sup>e</sup> étage  
F-59000 Lille [France]  
T: +33 (0)3 20 21 84 85  
www.interreg4a-2mers.eu

## On the project...

The A2S project made a quick start right after its approval by the Programme, building daily on its crossborder cooperation with an experienced and dedicated partnership. Over the years, the project progressed steadily and managed to gain attention from professionals and amateurs, from university professors as well as children. Now the time has come for it to show the results it has achieved. We hope these results will remain available and useful to everyone who is interested in maritime archaeology.

The Programme wishes to congratulate the partnership on the success of its project and we wish it all the best for the future. The Atlas of the 2 Seas project has been a true ambassador for the 2 Seas programme!

# Management

## A2S Project Funding: a budget of €2,774,462

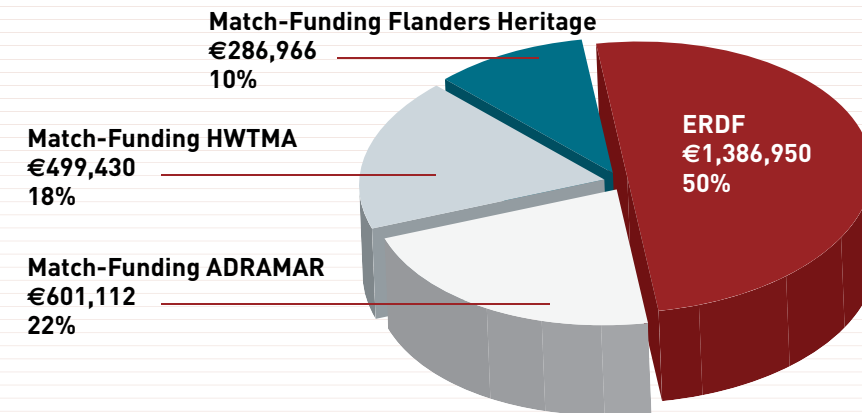

The A2S was approved on 8 July 2009 by the Steering Committee of the INTERREG IV A 2 Seas programme, during the third call for proposals. A total budget of €2,774,462 was approved for the period from 31 October 2007 to 30 June 2012.

## Financial aspects

The A2S would not have been possible without the 50% funding of the ERDF (European Regional Development Fund) and the match-funding from financial partners at national, regional and local level.

The ADRAMAR was financially supported by the DRASSM (Ministry of Culture and Communication), the Brittany region and the departments of Ille-et-Vilaine, Morbihan and Côtes-d'Armor.

The HWTMA has been supported in this project by English Heritage and the Heritage Lottery Fund.

Flanders Heritage, a state agency, assured its own match-funding.

The breakdown of the expenditures by activity shows that the largest share (35%) was devoted to fieldwork operations. The desk-based research, the integration of information in the partners' databases, communication and management each have a share of about 17%. The design of the Geoportal and its implementation correspond to a share of about 10% of the expenditure.

## Management aspects

In order to best manage the constraints of a project in the European programme, the project partners attended training seminars organized by the INTERREG IV A 2 Seas.

Management meetings of the project to review progress were programmed at the start of the project. During it working groups were formed to follow the implementation of the different activities.

Every six months the partners met for two or three days in one of the partners' organizations. In addition, meetings were held during fieldwork while communication via telephone or emails was ongoing. In addition to their scientific interest, the meetings and communication created a group synergy that has aided both project management and delivery of activities.

## Project progress reports every six months

Requests for payment from the ERDF were made after the submission of project progress reports which recorded the completion of tasks against the stated claims of the approved application.

Six progress reports, consisting of an activity and a financial report, were produced every six months.

After approval of the progress report by the JTS and the Managing Authority (Regional Council of Nord-Pas de Calais), the Certifying Authority transferred the grant to Adramar as the lead partner. In turn Adramar distributed the appropriate share of the grant to the other partners. ■





## Hydrographic records

In France the Hydrographic records are maintained by the Naval Hydrographic and Oceanographic Service (SHOM). In Belgium, they are housed in the Flemish Hydrographic archives (Agency for Maritime Coastal Service - Departement of the Coast) and the Maritime Access division of Mobility & Public Works Department, while in the UK data are held by the UK Hydrographic Office (UKHO).

← New Reduced Chart of the Channel. To serve the king's ships 1749. Mr Bellin. © Museum of Saint-Malo (FR) - T.Seguin/ADRAMAR



← Archival records are precious for the archaeological research.  
© The National Archives (UK)

## National inventories

France has the national database of the Ministry of Culture and Communication (*Patriarche*) and the archives of the *DRASSM*. In Belgium, maritime archaeological data is stored in the Flanders Heritage Agency public database with online access at [www.maritime-archaeology.be](http://www.maritime-archaeology.be). In England, the *National Monuments Record* (NMR) helped by *English Heritage* holds the public archive of 48,000 monuments. It can be accessed online via 'PastScape' at <http://pastscape.english-heritage.org.uk>.

# Desk-based research

The rationale for desk-based research within the A2S project was to build up a database of our mutual submerged cultural heritage, gather more data about known shipwrecks, locate new sites and learn about unidentified wrecks. Data are brought together through desk-based study of existing documentation.

## Building databases

A database contains comparable details about underwater sites which can be queried by researchers or the wider public. The construction of the database has allowed information to be accessed through a web based Geoportal which is a core element of the A2S.

Sources of documentation interrogated include National archives and inventories, Hydrographic Office records, plus primary, and secondary material. Charts, geophysical survey data, photographs and other salient records were entered into the database.

National inventories and archives contain information on archaeological and architectural monuments. This can encompass wreck sites, reported shipping casualties, crashed aircraft, net snaggings, maps, charts, photographs, isolated finds and submerged prehistoric landscapes.

Hydrographic offices hold national archives of current and historic information acquired when the sea floor has been charted. They hold extensive collections of historic charts, modern bathymetric data and information on ship losses. They also hold records of all known wrecks to ensure safe navigation for modern shipping. In the first instance much of the data can be received in digital formats,

providing essential summary data suitable for the primary fields in the database.

## Increasing understanding

Many thousands of known and unknown wrecks are listed in established databases and in many cases the detail recorded is sufficient for research or management purposes. However, there are a number of wreck losses that warrant further investigation. This can be because they help provide information about little known periods or aspects of our common past, because

they are under threat or because they can provide information needed to satisfy a collective European quest for understanding. Where more information is needed, further levels of investigation have been conducted into primary and secondary sources.

Primary sources include documents that are directly related to the subject matter. This can include ships' plans, logs, manifests, port records, contemporary correspondence, prints and old photographs. These documents can be found at the national inventories, regional museums or the archives of shipping companies, insurance agencies or the repositories of national navies.

Further information can be gathered through secondary sources. These are publications that have previously interpreted and published primary sources. They are produced mainly by archaeologists, historians or sometimes journalists. They can be found in scientific journals, books, monographs and newspapers and are therefore widely dispersed. These sources often give an interpretation of the general historical and archaeological context.

Where desk based assessment did not satisfy the questions being asked, work in the field was deemed necessary.

## New and unidentified wrecks

Many shipwrecks have yet to be found and many discovered wrecks have yet to be identified. When looking to locate unknown wrecks and when looking to interpret archaeological investigations of unknown wrecks, additional areas of investigation were necessary.

To locate possible wreck sites information about maritime trade routes, international conflicts, ship types, old newspapers and ship loss records were studied. The results were coupled with inspection of historic charts, modern charts and geophysical data from the seabed. Where an unknown wreck was investigated, ships' plans, logs, manifests, port records, cargo characteristics, passenger lists and an understanding of life on board all helped to answer the mystery it presented.

## Results of the desk-based research

The desk-based research involved the location of documentary and visual sources within each partner country. By working in collaboration, the A2S project has identified, located and brought together dispersed datasets.

The various documentary sources consulted during the desk-based study have provided new historical insights. However, documentary sources are inevitably partial and often fragmentary. The archaeological record is also fragmentary, but avoids the bias of human interpretation. By combining information from both documents and archaeology, a far more powerful and objective historical tool is created. Therefore, within the context of the A2S project, a combination of historical and archaeological data has been gathered and made publicly available through the Geoportal. ■



Zeeleeuw, Flemish research vessel (BE).  
© Onroerend Erfgoed/A2S

# Archaeological survey

One of the main objectives of the A2S project is the 'survey of archaeological sites under water to enhance understanding of our submerged cultural heritage'.

**D**esk-based research alone is not sufficient to grasp the archaeological heritage under water in its entirety.

It is necessary to go and look on the spot for different reasons:

- In sites which are only known through the detection of an anomaly on the seabed or by an archival document, the accuracy of the known position needs to be verified. Furthermore, the characteristics and the significance of the remains may need to be determined.
- For sites where information is already known, detailed investigation can

increase our knowledge of the wreck or its structure. It can reveal technical aspects or the cause of the shipwreck. In many cases site investigation can help establish the date and origin, or even the identity, of the ship.

- Finally, regular monitoring of the condition of known sites is essential. It helps us to understand the factors impacting underwater sites and to predict possible threats to their conservation. Sediment-erosion patterns, for instance, can cause a site to degrade, but can also protect it.

The A2S project tries to maintain as broad a perspective as possible on maritime

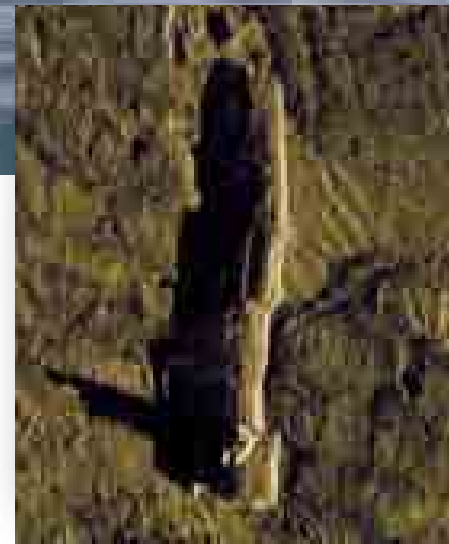

↑ Side-scan sonar image of the submarine U171 (FR).  
©ADRAMAR/A2S

archaeological heritage by giving attention to underwater wreck sites as well as to submerged or partly submerged landscapes and structures.

Each project partner made its own selection of sites to be investigated during the project. These were selected based on research priorities and national programmes. However, the international approach of the project provided 'added value' in many ways. For example, submerged prehistoric landscapes in French and English waters could be compared, foreign wrecks like the English warship HMS *Wakeful* in Belgian waters or the French SS *Azemmour* steaming



Diver taking measurements on a gun on the ZI 24 shipwreck (FR). © T. Seguin/ADRAMAR/A2S

“Through the on-site research and cross-border cooperation, one of the central aims of the project has been realized.”

in English waters were investigated while the 'multi-national' SS *Londonier* was studied by researchers from the three project nations (see page 60).

Through the on-site research and cross-border cooperation, one of the central aims of the project has been realized. The international team of archaeologists shared experience and best practice in archaeological techniques and different underwater research methods. Students and volunteers actively participated in the surveys and gained practical experience in the methods of maritime archaeology. The involvement of such a diverse group of people furthermore helps to raise a wider awareness regarding maritime heritage and ensures continued and efficient cooperation in the future.

## Survey techniques

Throughout the project, different surveying methods were used. Geophysical methods allow for the assessment of a site from a distance, without directly interfering with it. Several techniques are available and may often be combined, depending on the nature of the site and on the information required. Thus, on the intertidal site of Raversijde, in Belgium, electromagnetic prospection has been used to map the variation in the nature of the subsoil. This allowed archaeologists to distinguish between peat, sand and man-made structures thought to be of late-medieval date.

Multibeam and side-scan sonar are used to map height differences and provide

acoustically generated images of wreck sites on the seabed. Seismic surveys produce virtual cross-section images of the seabed that expose underlying layers. This can be helpful in reconstructing ancient landscapes.

Other techniques require the researchers, usually divers, to be physically present on the site. These 'ground-truthing' techniques range from simple observation of the site through the creation of detailed plans of the visible remains, development of photographic and video records, to more intrusive methods such as coring, sampling and ultimately, excavation. In addition, some sites have been monitored over a period of time by establishing and reviewing the condition of fixed reference points.

The data that have been gathered on the target sites during the project have been disseminated through different initiatives aimed at the general public and will enrich the project's database. ■

# Case studies

The following case studies show the large variety and broad chronological span of the different research subjects studied by the partnership during the A2S project. These investigations are addressing archaeological research questions to enhance our knowledge of the underwater cultural heritage preserved beneath the Channel and the North Sea.

**100** sites have been investigated by the partners during the A2S project they are shown on the map. Eleven of these case studies are presented to show the potential of the underwater cultural heritage of the Channel and North Sea area. They prove that cross-border collaboration between the countries enhances our knowledge through the exchange of information, the involvement during archaeological operation and the dissemination of the results as a common heritage to the public.

The archaeological sites, investigated within the A2S project, range from Prehistoric submerge landscapes like the Biéroc-la-Mondrée and Bouldnor Cliff sites, to Second World War shipwrecks like HMS *Wakeful*. They also encompassed a medieval submerged settlement at Raversijde beach and modern losses like the Z124 shipwreck, *'t Vliegende Hart* and *Flower of Ugie*. The research had the objective to target several sites that were of a common interest and within the national priorities. In addition new and existing geophysical and archaeological techniques have been combined and tested on sites on the beach or underwater for possible application in archaeology.

To conclude, the case study of the SS *Londonier* is an example of the integration of all the actions of the A2S project. ■





→ The distinctive hawse holes visible at the northern end of Alum Bay 1. Extant copper fastenings and surviving timber remains are clearly visible in the foreground (UK).  
© M. Pitts.

# Archaeological Research

During the course of the A2S project, the HWTMA has conducted archaeological investigation, often in collaboration with A2S partners, of a wide range of shipwreck sites located within the English area of the 2 Seas zone. This work has enhanced our knowledge of these important elements of our shared underwater cultural heritage while building the capacity to conduct similar work in the future.

By Julian Whitewright

The successful application of archaeological survey has been at the heart of the HWTMA contribution to the A2S project. Desk-based research conducted identified many hundreds of wrecks located within the English area of the 2 Seas zone. Many of these were deemed worthy of further research, including archaeological investigation and geophysical survey. It was recognised that such fieldwork would enhance the information already contained in the A2S Geoportal. Some of these wrecks are now discussed and illustrate a variety of post-medieval watercraft, ranging from British sailing men of war, a Dutch merchant schooner, a 19<sup>th</sup>-century clipper ship and Second World War casualties including a U-boat and D-Day landing craft.

## Alum Bay

Alum Bay is located on the north-west tip of the Isle of Wight, a short distance from the Needles. The bay is the site of a number of underwater archaeological remains, including two shipwrecks, the remains of a 19<sup>th</sup>-century pier and numerous scattered, individual artefacts. The largest section of shipwreck remains, termed Alum Bay 1, is a section from HMS *Pomone* which sank on the Needles in 1811. The remains of HMS *Pomone* that are located at the Needles are now a Protected Wreck under UK law. Alum Bay 1 lies in 7-8m

of water and is preserved to a length of 19m. The remains are one upper side of the bow of HMS *Pomone*. Features such as the anchor hawseholes are preserved along with several gun port openings, offering a rare glimpse of these areas of a naval vessel that are not usually well-preserved in the archaeological record.

Nearby is the site of Alum Bay 2, the remains of a much smaller, carvel-built vessel that now lies upside down in the sandy floor of the bay. The identification of this vessel is still unknown, but it is clearly much smaller than Alum Bay 1 and may represent one of the boats from HMS *Pomone* or a vessel-type such as a fishing boat or excise cutter. Examples of these are documented as having been lost at the Needles. Work in Alum Bay has been on-going since 1991, surveying and recording the various archaeological features. In 2010 an A2S team comprising archaeologists from England, France and Belgium conducted a week of archaeological diving on the site of Alum Bay 1. This work increased our knowledge of the site through the excavation of a section of the remains that had previously only been subjected to a surface survey. Much new information was uncovered, including the disposition of structural timbers around some of the surviving gunports. The archaeological work in Alum Bay conducted through the A2S project is being built upon further by the HWTMA through an English Heritage-funded project which will allow further historical research to complement existing archaeological data gathered on all of the sites.



↑ The A2S Anglo-Belgian dive team make final preparations before a dive at Alum Bay in 2010 (UK).  
© HWTMA/A2S

→ A2S diver inspecting a set of deadeyes on the port side of the wreck of the *Smyrna* (UK).  
© D. Robbins.

## Smyrna

Many known wrecks are located close to the coastline of the 2 Seas zone and often a great deal is known about such wrecks because they are easily accessible. Further offshore, in deeper water, it is far harder to gather archaeological information required to enhance the A2S. One vessel which falls into this category is the *Smyrna*, an iron sailing clipper that sank in 1888 and lies in 55m of water, 26km south-east of the Isle of Wight.

*Smyrna* was built in Aberdeen by Walter Hood in 1876 and is representative of one of the most famous classes of merchant sailing ship; the clipper. Designed to convey passengers and high value cargoes as rapidly as possible around the world, vessels like the *Smyrna* were economically viable only because of the speed at which they could travel with an enormous suite of square-sails and a relatively large crew to operate them.

On 24 April 1888, the *Smyrna* was outward bound from London to Sydney. The previous year the vessel had made the voyage from Sydney to Aberdeen in 96 days. The vessel entered a fog bank under sail at 10.30a.m. and shortly afterward was struck by the SS *Moto*, bound from Bilbao to Newcastle. *Smyrna* was severely damaged and began to take on water, sinking shortly afterwards with the loss of 11 of her crew of 29 and the only passenger on board.

The vessel was rediscovered in 1993 and a range of artefacts have since been salvaged, including the vessel's nameplate and items of cargo. The ship was reported as being in good condition with many elements that usually rapidly disappear, such as parts of the lower



rigging, still preserved. The lack of archaeological diving on the remains of the *Smyrna*, coupled with its offshore location, made the remains of the vessel an important way to extend the activities of the A2S project into deeper water. At the same time, the condition and extent of the vessel could be properly assessed for the first time.

A2S divers visited the site of the *Smyrna* in 2010 as part of targeted diving on a number of shipwrecks located in deeper water to the south of the Isle of Wight, none of which had ever been the subject of archaeological diving before. This work enabled the measurement of key archaeological features to be undertaken and for a photographic and video record to be created. For the *Smyrna* and the other deep water wrecks, this information will serve as the underlying data that will allow them to be properly monitored in the future. This archaeological information also provides an important physical correlation to the material gathered on such vessels during historical and desk-based research. Finally, the experience of working at increased depths will enhance and improve the capacity of maritime archaeologists operating in the 2 Seas zone to provide coverage for all sites in the future, no matter where they are located. ● ● ●



The ghostly remains of U-1195 still lie preserved on the seabed of the eastern Solent (UK). © HWTMA/A2S



The SS Cuba lists to port prior to sinking. Lifeboats are visible to the right of the ship.



A Centaur CS IV tank on the beach at Courseulles, Normandy.

## Second World War shipwrecks

The seabed remains of *U-1195* are located in the eastern Solent, 18km east of the Isle of Wight and 28km south-east of Portsmouth. The vessel is a German MkVIIC submarine that was commissioned in November 1943 and was sunk by HMS *Watchman* on the 6 April 1945. On the day of its sinking, *U-1195* was responsible for sinking the troopship *Cuba* in the eastern Solent. Both the *Cuba* and *U-1195* have been dived on during the A2S project to enhance the information developed during desk-based research. The latter has revealed the wealth of existing documentary evidence about both vessels and the day of their loss.

For much of its career *U-1195* operated as a training vessel within the Kriegsmarine before eventually putting to sea on active service in early 1945 under the command of Ernst Cordes. Prior to the sinking of the *Cuba*, Cordes and *U-1195* sank an American Liberty ship off Plymouth. The submarine is not an especially rare vessel-type; over 500 type VIIC boats were commissioned between 1940 and 1944. But the vessel is an important reminder of the events of the Second World War as well as acting as a lasting monument to Ernst Cordes and his crew who died in the sinking of the vessel.

The *Cuba* was built in 1923 in Newcastle, England and was originally a ocean liner for the French CGT line, operating on the Saint Nazaire – West Indies – Vera Cruz route. She was taken into the Royal Navy in October 1940 and converted to a troop transport ship. In this capacity the *Cuba* could carry as many as 3,000 people between England and France. The vessel was returning from France on 6 April 1945 and was less than 1,6km from the anti-torpedo net gate off Portsmouth when it was struck by a torpedo from the *U-1195*. The vessel took 56 minutes to sink, during which time her crew were rescued, with the exception of one man who was killed in the initial torpedo impact.

Diving on these two vessels, whose final days are so inter-linked, took place through the A2S project in 2011 and involved divers from England and Belgium. No archaeological diving had previously taken place on either of the sites and their physical condition remained unknown, including the effects of salvage operations during the 1950s. A2S divers successfully confirmed the exact location of these wrecks, completed extensive photographic and video surveys of both sites and were able to establish the underlying condition of remains. The latter will be crucial for the effective future monitoring and management of these important symbols of Europe's armed struggle during the mid-20<sup>th</sup> century.



↑ Geophysical image of the remains of the Fenna (UK). © HWTMA/A2S

## Geophysical Investigation

*Fenna* is the well-preserved remains of a Dutch schooner which sank west of the Needles in 1881 while en-route to the Mediterranean. The cargo of the vessel is still perfectly preserved in its original configuration on the seabed in 20m of water. In December 2010, the HWTMA, through the A2S project and in collaboration with Kongsberg GeoAcoustics conducted a detailed geophysical survey which produced a clear overall image of the site.

## Memories of D-Day: LCT(A) 2428 and vehicle assemblage

The seabed remains of LCT(A) 2428 and its associated vehicle assemblage represent a unique archaeological site within the English 2 Seas zone. The vessel is a Second World War landing craft designed to convey tanks to the D-Day beaches in June 1944. The tanks that were carried on board LCT(A) 2428, along with two armoured bulldozers for clearing the beaches, were Centaur Mk IV tanks that were unique to the unit of Royal Marines were tasked with providing close fire support on the way in to the D-Day beaches. The vessel broke down and capsized while under tow in the eastern Solent while en-route to Normandy on the eve of D-Day. Its cargo of vehicles was spilled on to the seafloor in the same configuration in which they sat on the decks of the landing craft. The vessel remained afloat, posing a potential hazard in the busy shipping lane, before eventually being deliberately sunk by the naval tug in attendance.

The initial archaeological investigation of the two sites, one for the vessel and one for the vehicles, was done by divers from Southsea Sub Aqua Club (SSAC). Following this, a

collaborative project (the Landing Craft Project) between SSAC and the HWTMA and funded by English Heritage and A2S, was launched to conduct further survey work on both sites, resulting in two complete site plans for the first time. Archaeological work on the sites was carried out by divers from SSAC, HWTMA and A2S partner countries. In addition, the project also provided a case study to assess whether English legislation designed for terrestrial archaeological remains could be successfully extended to the marine zone.

The Landing Craft Project achieved all of its aims and objectives. Archaeological knowledge of these two sites was greatly increased, while accompanying historical research revealed that the Centaur tanks are two of only five now surviving worldwide. The project allowed archaeologists and volunteer divers to collaborate, and the final project report offered recommendations for the future legislative management of England's underwater cultural heritage.

## The future

Our shared knowledge of the underwater cultural heritage located off the coast of southern England has been greatly enhanced and developed as a result of

the archaeological fieldwork carried out through the A2S project. This work has built upon the firm foundations laid during the desk-based assessment and documentary research. But it also feeds back to, and directs, that work to allow it to be more specifically targeted in the future. The archaeological fieldwork undertaken by the HWTMA through the A2S project has also allowed the development of techniques and mutual learning as a direct result of the inherently collaborative nature of the fieldwork. Finally our capacity to conduct future work – at the desk, on the boat or underwater – have all been increased and improved through the successful application of work conducted under the aegis of the A2S Project. ■

## References

- Whitewright, J. (2011). *LCT(A) 2428: An assessment for Scheduling in the Marine Zone*. HWTMA on behalf of English Heritage, 32 p.
- Whitewright, J. & Satchell, J. (2010). *Solent Maritime Heritage Assets. The Fenna: Site Assessment*. HWTMA, 33 p.
- [www.hwtma.org.uk/alum-bay](http://www.hwtma.org.uk/alum-bay)
- [www.hwtma.org.uk/fenna](http://www.hwtma.org.uk/fenna)
- [www.hwtma.org.uk/LandingCraft](http://www.hwtma.org.uk/LandingCraft)
- [www.hwtma.org.uk/Smyrna](http://www.hwtma.org.uk/Smyrna)





→ Hermine Bretagne, ADRAMAR's research vessel during the geophysical survey off the coasts of Saint-Malo (FR).  
© T. Seguin/ADRAMAR/A2S

# Geophysical survey off the French coast

## research and enhancement of archaeological sites

Three geophysical survey campaigns were conducted in French waters between 2009 and 2011 targeting archaeological sites of the Ile-et-Vilaine, Morbihan, Côtes-d'Armor and Pas-de-Calais departments.

*By Alexandre Poudret-Barré, Erwan Marion, Victor Laforêt, Denis Dégez, Olivia Hulot, Jean-François Jeu and Alain Richard*

The objectives of these operations were to calibrate detection equipment, to document known wreck sites, to survey areas with a high archaeological potential, to check the geographical coordinates of a few sites and their state of conservation and to set up an image and film base of these sites.

To fulfil our objectives, we contacted our collaborators to collect relevant information and documentation about the areas to be surveyed. Jean-Maurice Authié, Patrice Cahagne, Michel Cloâtre, Daniel David, Emmanuel Feige, François Floch, Jean-Pierre Génar, Franck Jouet, Jean-Michel Keroullé were closely associated to the set up of operations in Brittany. The survey at Boulogne-sur-Mer was different as we were invited by Jean-François Jeu and Alain Richard of CODEP 62 to take part in a coordinated project and bring in our expertise and equipment to perform a side-scan sonar analysis of several sites.

The examples presented here testify to the valuable contribution of geophysical surveys to the problematics of research and enhancement of underwater archaeological sites.

### The tragedy of the *Artiglio*

The *Artiglio* was bought in 1926 by SORIMA, an Italian underwater operations company specializing in the rescue of wrecked ships' cargo and the scrapping of wrecks which might pose a navigation hazard.

In 1930, SORIMA obtained a contract to level of the wreck of the *Florence H*, a vessel which had sunk on April 17, 1918 with a cargo of several hundred tonnes of black powder. On 7 December 1930, the *Artiglio's* tender was sailing away after a scuba diver had placed four blasting charges onto the wreck of the *Florence H*. The *Artiglio* and the tender were still too close to the wreck site when the explosives were lighted and they were also blown up by a huge explosion, killing twelve of the nineteen crew members. Witnesses to the scene reported that they had seen the bottom of the sea at the time of the blast, while others said that the *Artiglio* was lifted up at a considerable height before it fell back and sunk in less than 45 seconds (Rabault 1995). Ironically, the company in charge of clearing the *Artiglio* in 1932 was SORIMA, and

its wreck was savaged commercially in the second half of the 1990s (L'Hour & Veyrat 2005).

After submitting both wrecks to a side-scan sonar analysis, we were able to draw a plan allowing for a better understanding of the site: the wrecks lie 180m apart from each other. The tender is clearly visible 35m south of the *Artiglio* which is resting on its keel with a preserved length of nearly 45m and 3m in height while the debris of the *Florence H* is scattered over more than 70m<sup>2</sup>. Eighty years after the wrecking of the *Artiglio*, the scene seems to have been preserved, as if it were 'frozen' some 20m under water.

### A gun scatter off the coast of Quiberon

The scatter was declared to the French 'Marine Nationale' in 2006, and had been accurately located, but no information was available regarding the number of cannon, their depth of burial or indeed the site's configuration. Our strategy was systematically to cover a 178,000m<sup>2</sup> wide area with a side-scan sonar and magnetometer survey.

The sonar cover identified 14 scattered cannon. We positioned the *Hermine-Bretagne* directly above the cannon to be surveyed (one at a time), based on the analysis of survey data, in order to achieve an optimal organisation of the dives. The plan drawn from geophysical data also helped direct the divers under water, but the



Recording guns off the coast of Quiberon (FR).  
© T. Seguin/ADRAMAR/A2S

→ Side-scan sonar of Artiglio and Florence-H (FR).  
© ADRAMAR/A2S





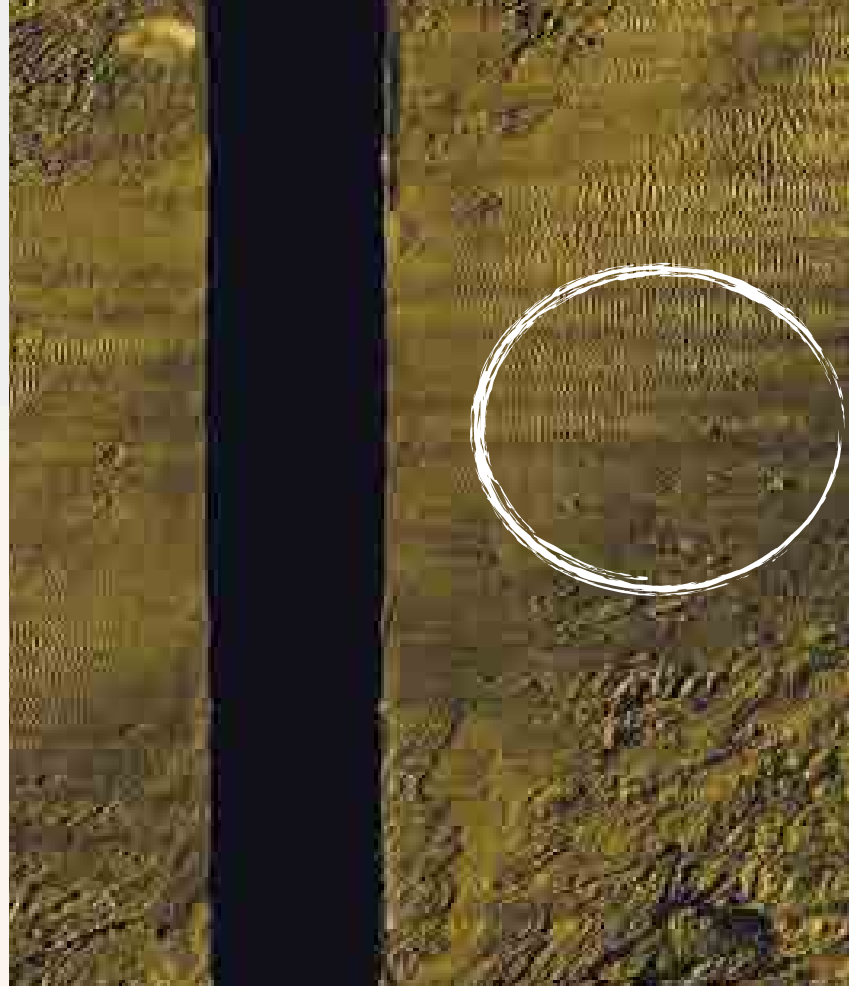

→ Side-scan sonar of a gun scatter off the coast of Quiberon (FR).  
© ADRAMAR/A2S

••• recording of all the cannon was not possible as the site was spread over a more than 70m wide area.

The cannon are probably made of cast iron, and their relative position to one another gives no clue as to whether or not they belong to the same wreck. The fact that they are not buried or aligned on a single axis, as would be expected in the instance of un-ballasting a distressed vessel, seems to indicate that this scattering is due to repeated trawling rather than to an incident at the time of their loss. If the cannon are, at all, related to one or two wrecks, these are still to be located. In light of this initial operation the site deserves a further survey so that all the cannon can be recorded. Trial excavations could then be conducted to look for any associated wreck material.

## The wrecks of La Natière

The site of La Natière where various wrecks are lying under water was searched for 10 years by Michel L'Hour and Elisabeth Veyrat's team (2001; 2002; 2003; 2004). Two major wrecks were found which were astonishingly well preserved considering the time they had spent underwater. Thanks to data gathered through parallel research in the field and in the archives, both wrecks were identified as early 18<sup>th</sup>-century privateer frigates, i.e. the *Dauphine*, a royal

frigate fitted for the 'guerre de course' which sank on 11 December, 1704 while she was escorting a captured English ship to the port of Saint-Malo, and the *Aimable Grenot*, a trading vessel loaded with canvas which was wrecked on 6 May, 1749 as she was leaving the port of Saint-Malo, bound for Cadiz. While working on this outstanding site, researchers could study the two naval structures with more than 3,000 artefacts being brought to the surface. In order to preserve the site. In 2008 the timbers were covered with 'geotextiles', then filled with sand. The purpose of the side-scan sonar surveying campaign was to check the condition of the sand layer covering the site.

The side-scan sonar image shows a depression due to the excavation of the *Aimable Grenot*, whereas the wreck of the *Dauphine* is less visible. The sonar image and the on-site exploration by divers showed that the sand-filled level is not enough to make up for the lack of sediment caused by the excavation. Additional analysis in May 2010 revealed little difference in the level of the sand layer between the sets of survey data. For this reason, a campaign was set up in the autumn of 2010 to bring yet more sand to the site. This proved sufficient to ensure adequate protection.

The surveys proved that it is essential to monitor the sand levels following the end of an archaeological dig as this was, and is, the only way to ensure full protection of the remains for future generations.



← Side-scan sonar of Laplace (FR).  
© ADRAMAR/A2S

## The motor torpedo boat of Cap d'Alprech

The wreck of a motor torpedo boat was discovered during the 1988-1989 diving season and was regularly visited afterwards by divers of the Club Sous-Marin de la côte d'Opale. A very damaged hull was observed lying flat, deeply buried in sand on the sea bottom. An outstanding feature was the presence of two torpedo tubes with bevelled termination and no streamlining. The wreck bears no resemblance to an armoured vessel. A few years later, a propeller was brought up by a trawler near the site, and the inscriptions found on it confirmed that this was the starboard propeller of German motor torpedo boat *S 189*, an armoured vessel which had been sunk by the British forces off the coast of Boulogne-sur-Mer a few days after D-day. Since *a priori* this was not a propeller from the motor torpedo boat which was discovered, more field and archival research was initiated to establish the relationship between the propeller and the wreck. This is when we got involved in the project's underwater investigation, using side-scan sonar, under Jean-François Jeu and Alain Richard's supervision.

The sonar analysis of the site provided a global vision of the remains surrounding the wreck of the motor torpedo boat. Both torpedo tubes were displaced outside the wreck's port side, possibly by a trawler. Three inconsistent artefacts were spotted in the nearby area. The first is very probably a propeller which has been dragged from the north for at least 45 metres. The second might be a fragment of the armoured wheelhouse of a motor torpedo boat. The third could be the spare torpedo, reported

on site in 1991 and which has since disappeared, being trawled some 47 metres away from the site. Review of the side-scan sonar data therefore opened up new diving investigations to determine whether this is indeed the *S 189*'s armoured wheelhouse, recording any inscriptions written on the propeller, and formally identifying the wreck.

Geophysical surveys are an appropriate tool to record the remains of contemporary wrecks and assess their level of preservation. Archival research into relatively recent losses is also an essential component of investigation, providing an insight into material remains (Richard *et al.* 2013). The collaboration between divers who are real history enthusiasts and archaeologists was more than just about technical, human and scientific assistance; indeed it was a valuable opportunity to make contacts and exchange experiences.

## Conclusion

It seems essential, considering the above-mentioned operations and collaboration between partners, that the people in charge of heritage management – along with scuba diving clubs and amateur divers and scientists – should start exchanging views on ways to establish policies applicable to the ongoing management of excavated archaeological sites and sites containing contemporary wrecks. Such a dialogue should define the objectives to be met and the possible participation of the various parties in order to set up management and monitoring protocols. Only through collaboration between the actors at local, national and European level will the study, protection and enhancement of our submerged heritage be achieved. ■

↓ Torpedo tube of the motor torpedo boat S189 (FR).  
© I. Richard

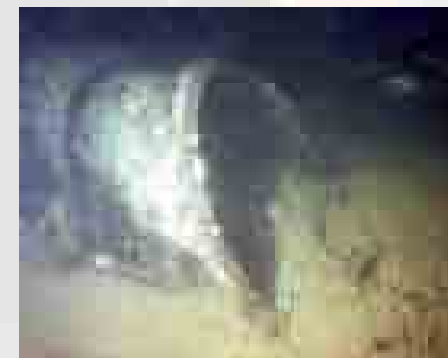

## References

- Rabault, C. (1995). *L'or et la griffe*. Rennes: Editions Terre de Brume, 192 p.
- L'Hour, M. & Veyrat, E. (2001). *Un corsaire sous la mer, les épaves de la Natière. Campagne de fouille 2000*. Concarneau: ADRAMAR, 108 p.
- L'Hour, M. & Veyrat, E. (2002). *Un corsaire sous la mer, les épaves de la Natière. Campagne de fouille 2001*. Concarneau: ADRAMAR, 108 p.
- L'Hour, M. & Veyrat, E. (2003). *Un corsaire sous la mer, les épaves de la Natière. Campagne de fouille 2002*. Concarneau: ADRAMAR, 132 p.
- L'Hour, M. & Veyrat, E. (2004). *Un corsaire sous la mer, les épaves de la Natière. Campagne de fouille 2003*. Concarneau: ADRAMAR, 128 p.
- L'Hour, M. & Veyrat, E. (2005). *La Mer pour Mémoire*. Paris: Somogy et Association Buhez, 396 p.
- Poudret-Barré, A. ed. (2011). *Rapport de la campagne de prospections et d'expertises sous-marines au large de l'Ille-et-Vilaine et des Côtes-d'Armor*. Domagné: ADRAMAR, 79 p. [unpublished research report]
- Poudret-Barré, A., Marion, E., Dégez, D. (2010). *Rapport de prospections et d'expertises sous-marines au large du Morbihan et de l'Ille-et-Vilaine*. Domagné: ADRAMAR, 2 vol., 74 p. & 36 p. [unpublished research report]
- Richard, A., Richard, I. & Jeu, J.-F. (2013). *Plongées en côte d'Opale. Tome 3*. Boulogne-sur-Mer: CODEP 62. (in press).





← Printed map by Johannes van Keulen showing the location of the wreck sites of Anna Catharina and 't Vliegende Hart. This map was based on an map of Abraham Anias of 1736. © Hildred, 2001

# 't Vliegende Hart

During the years 2010 and 2011 of the A2S project, the 18<sup>th</sup>-century wreck site of 't Vliegende Hart received special attention. By archival research, a series of extensive on-site registration surveys in very bad circumstances and by geophysical methods, the A2S team tried to unravel the many secrets of a site that captivated the minds of both researchers and the general public.

By Ine Demerre, Tine Missiaen, Inge Zeebroek and Pieterjan Deckers

## History and background

The Dutch East Indiaman 't Vliegende Hart, a c.44m long three-master carrying 42 guns, was built in 1729-1730 in Middelburg. On 3 February 1735, carrying a cargo of wood, building bricks, iron, gunpowder and wine, as well as several chests of gold and silver ducats, it left the Dutch port of Rammekens near Vlissingen in convoy with a smaller ship, the *Anna Catharina*, and a pilot boat. The same day both ships ran aground on a sandbank in the Deurloo channel. Over 400 men were lost on both vessels (Van der Horst, 1991).

After several salvage attempts, knowledge of the wreck was gradually lost. Only in 1977 it did receive renewed attention when a manuscript chart was discovered, showing the exact position of the two wrecks.

Following this exciting discovery, retired British lawyer Rex Cowan obtained a concession for the search and recovery of the wreck from the Dutch Ministry of Finance, which to this day is responsible for VOC property. Between 1981 and 2007 several controversial excavation and salvage campaigns were carried out by an Anglo-Dutch diving team (Bruyns & Van der Horst, 2006). Regrettably, the structural remains of the wreck received little attention during these treasure-oriented diving sessions.

## Research during A2S

With the establishment of a Flemish marine archaeological research entity, interest in this wreck in Belgian territorial waters received a new impetus. Using side-scan sonar and multibeam soundings by the Flemish Hydrographic Service and the Renard Centre of Marine Geology (RCMG, Ghent University), the wreck's exact position and state were determined. Currently, it seems almost completely buried and only small fragments of the wreck protrude from the sea floor.

In cooperation with the Dutch State Service for Cultural Heritage, archives relating to past salvage campaigns were consulted. These mostly concern the communication between various parties involved with the salvage works between 1977 and 2007, demonstrating how stakeholder interests, legislation and public opinion often conflicted. The few published reports focus mostly on diving methodology rather than the wreck structure or discovered artefacts (Missiaen *et al.*, 2012).

Armed with this knowledge and the new images, the A2S team performed a number of diving surveys of the wreck in 2010 and 2011. Strong currents caused by the tide and the proximity of the Scheldt Estuary limited diving opportunities, whereas suspended sediment from a nearby dredging dump-site usually reduced visibility to 50cm or less. Fortunately, occasional clearer conditions allowed the team to start detailed registration.

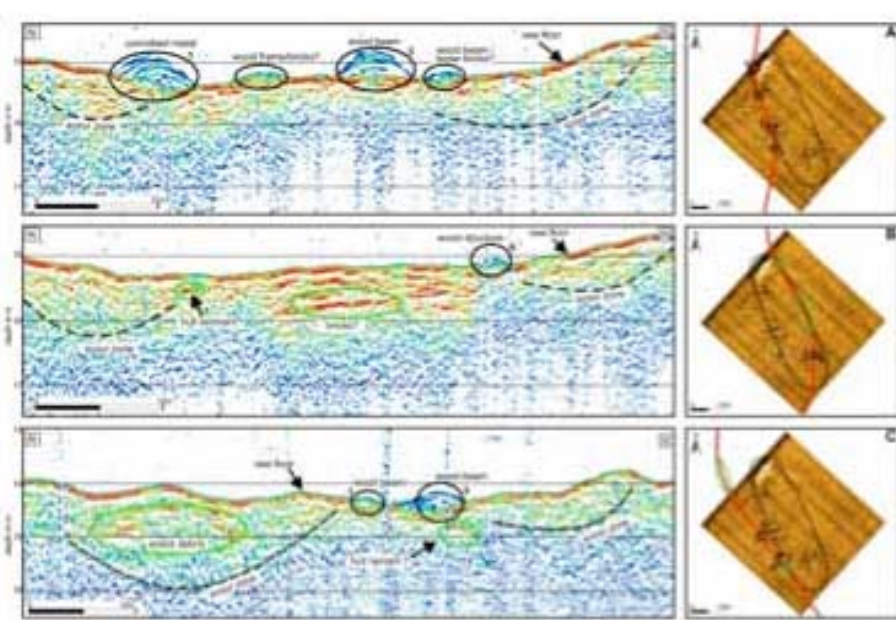

↑ Interpretation of 3 seismic profiles of the 't Vliegende Hart site (BE). © RCMG/A2S

→ A schematic overview of the exposed wreck remains observed in 2010 with top right: detail of the south eastern part and bottom right: multibeam image of the site (BE). © Agency for Maritime & Coastal Service - Département of coast - Flemish Hydrography/ Onroerend Erfgoed/A2S, 2010

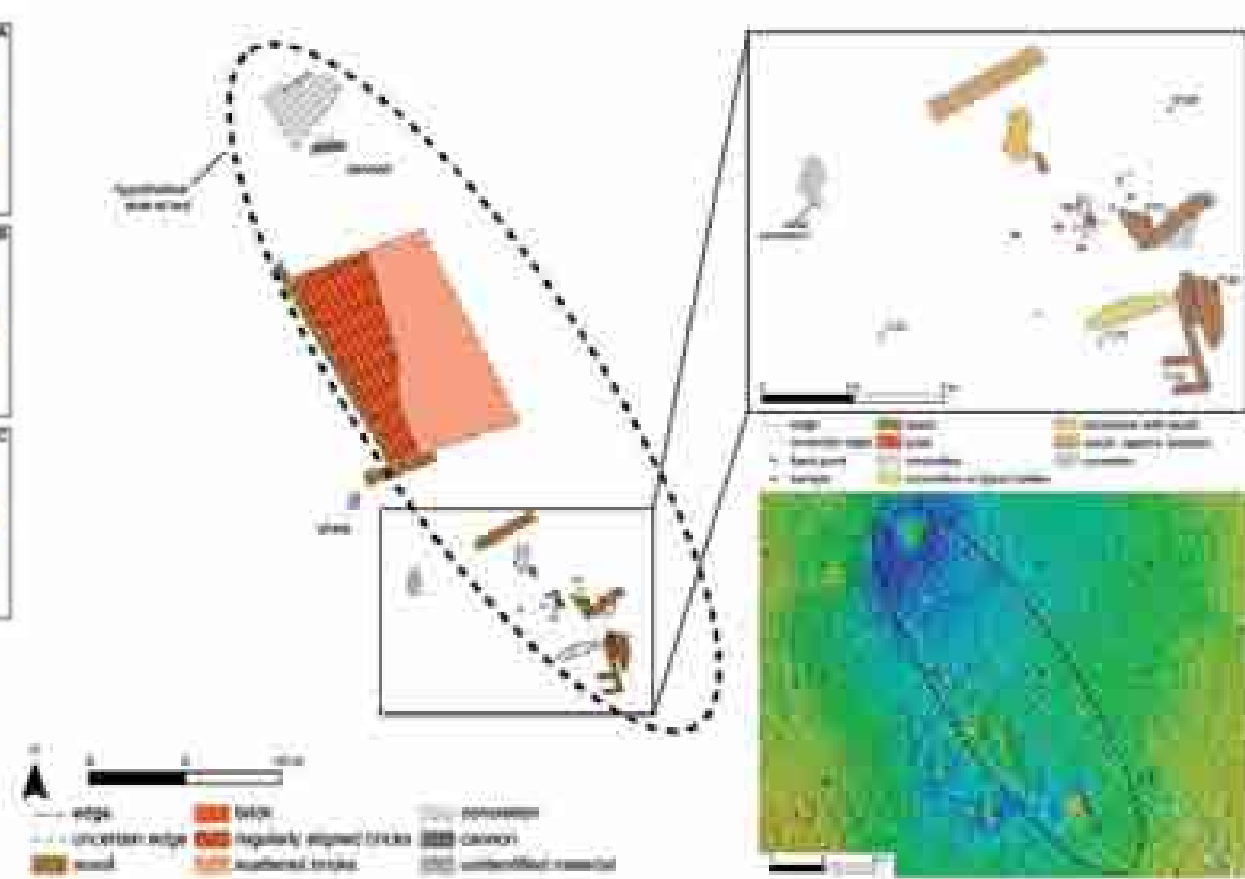

The visible remains stretch over a length of 37m, at a depth of 18m. As the stern section in the north-west contained the most valuable artefacts, previous diving had concentrated on this area. Structural remains in other parts of the wreck were recorded during the A2S surveys, including wooden beams and concretions of wood and metal near the bow. A possible cross-beam was recorded, as well as two long beams more to the south over and underlying close-set transverse wooden planking which suggest hull or ceiling planks near the ship's keel or bow.

Towards the centre of the site, an expanse of regularly aligned bricks represents a cargo of building material. Wood delineating the western edge of this area may form part of the hull structure against which the bricks were stacked.

Observations over two years of survey confirm that the wreck is subject to significant and rapid changes in sedimentation and erosion. The many sherds of 'onion-shaped' bottles and bricks also attest to continuing degradation, as do the fish-nets caught on wreck structures and even on recent registration pins.

Many of the wreck remains observed on the

seabed match prominent features on the side-scan and multibeam images. In order to refine the detail and broaden our knowledge, high resolution seismic data were acquired of top and subsoil by RCMG in 2010 (see also pages 32-33). Recognizable features are mostly related to the brick cargo. The ship's hull appears to have largely disappeared. Depressions with a stratified infill around the wreck are the result of scouring when the wreck was still (partly) exposed. Within these depressions, reflectors indicating layers containing debris are most pronounced to the east, which conforms to cargo spilling out of the listing ship's port side.

## Conclusion

Despite adverse conditions, the combination of archival study and various research methods are slowly revealing the secrets of 't Vliegende Hart. It is hoped that this initial project, and the international and multidisciplinary cooperation from which these data are the results, provides a stepping stone for further research and a more complete understanding of this valuable site. ■

## References

- Bruyns, W. & Van der Horst, A., (2006). Navigational equipment from 't Vliegende Hart (1735). *The International Journal of Nautical Archaeology*, vol. 35, n° 2, pp. 319-325.
- Demerre, I. & Missiaen, T. (2010). Speurtocht naar het wrak van 't Vliegende Hart. *De Grote Rede*, 28, pp. 1-8.
- Gawronski, J. & Kist, B. (1984). *'t Vliegende Hart report 1982-1983*. Rijksmuseum Amsterdam, 32 p.
- Hildred, A. ed. (2001). *VOC anniversary Shipwreck Project. Report on the excavation of the Dutch East Indiaman Vliegende Hart*, 60 p.
- Missiaen, T., Demerre, I. & Verrijken, V. (2012). Integrated assessment of the buried wreck site of the Dutch East Indiaman 't Vliegende Hart. *Relicta* (in press).
- Van der Horst, A. (1991). *Met geen drooge oog om tesien. De Ondergang van het VOCretourschip 't Vliegende Hart in 1735*. Amsterdam, 80 p.

→ Location of the site of Raversijde beach (1) and Raversijde polder (2) (BE).  
© Onroerend Erfgoed



# The site of Raversijde beach

## a test site for geophysical research techniques

The A2S project did not only focus on the study of wreck sites. Submerged settlements were also among the research subjects. One of these is a Late Medieval settlement at Raversijde beach. This has survived thanks to its present location on the beach where it is covered by sand and partly under water. In addition to the desk-based study of previous research results Flanders Heritage Agency had the opportunity to apply diverse and complementary geophysical research methods with the help of partners from Ghent University.

By Inge Zeebroek, Ine Demerre and Pieterjan Deckers

### History and location of the site

The site of Raversijde beach extends over a distance of about 2.5km between the Belgian coastal municipalities of Middelkerke and Mariakerke (Ostend). It is the only site within the project located both in the intertidal zone (between the tide marks) and in the subtidal zone (permanently under water).

Chronologically, the site covers a long time-span. Since the 19<sup>th</sup> century, researchers have discovered remains dating from prehistory up to the late Middle Ages. Until the end of the 1970s, these were visible on the beach, but exposed to marine erosion. Following the construction of groynes, they became covered by a layer of sand.

The prehistoric material primarily includes lithic artefacts dating from the Late Palaeolithic (30,000 - 10,000 BC) up to the Neolithic (5,300 - 2,000 BC). A wooden oven paddle was recovered from the top of the surface peat (locally dated between 3,012 +/- 61 - 814 +/- 15 BC (ref. KAI-20051 and KAI-20052)). Henceforth the paddle can be dated in the period between Neolithicum and Iron Age.

During the Roman period salt and iron production took place in this area. This is borne out by the remains of a system of wood-lined basins and ditches in which sea water was left to evaporate,

as well as a furnace and a pit filled with iron slags (Thoen, 1978). Refuse pits (Pieters *et al.*, 2010) and plough marks in the clay surface were also found. Behind the dunes, a Roman dike built with clay and peat was discovered during excavations in 2005. On the basis of old photographs from the Cools-Mortier collection, the dike could be traced as far as the beach. Even if all this cannot be considered as evidence for human settlement, these remains indicate intense activity in this area during the Roman period.

The most extensive remains belong to the Late Medieval fishing settlement of Walraversijde (13<sup>th</sup>-14<sup>th</sup> centuries). The settlement was originally located behind a dune barrier. Due to continuous erosion, its remains ended up on the beach. Various researchers have described remnants of houses with wooden and wattle walls, refuse pits and traces of peat extraction. Rows of houses extended along the beach over a distance of up to 1km.

For years numerous artefacts, notably of late medieval date, have been collected. Nowadays, these artefacts are spread over different public and private collections, including the museum at Raversijde. At the end of the 14<sup>th</sup> century, the inhabitants resettled inland, behind the current dune range, where archaeological research has been conducted since 1992.

→ Location of Late Medieval houses and a picture of the foundation of one of these dwellings in Mariakerke-Raversijde as recorded by André Chocqueel around 1936 (BE).  
© Chocqueel, 1950

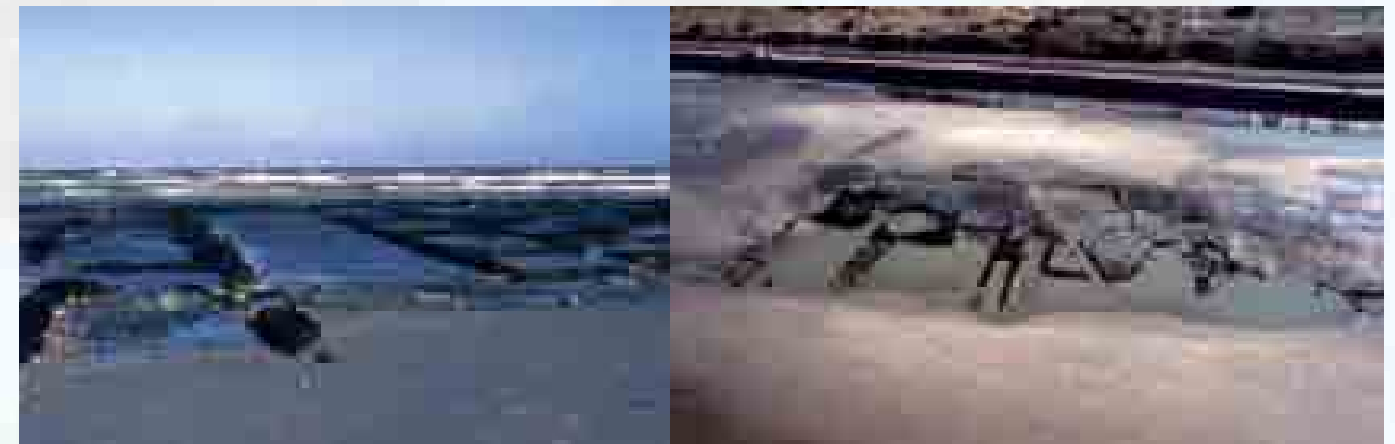
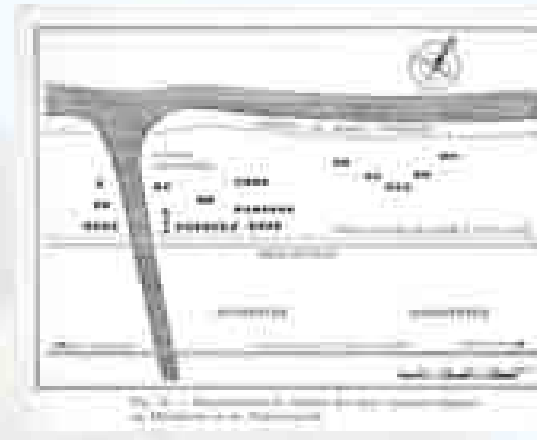

← Traces of peat extraction pits (BE).  
© Cools-Mortier.

### Desk-based study and on-site research

The study of the site of Raversijde beach within the scope of the A2S project consisted of two aspects: a new desk-based study and fieldwork. In addition to compiling an inventory of old discoveries and collecting new data, research offered the opportunity to compare different techniques on this special site. The results are disseminated through the A2S Geoportal.

The desk-based study consisted of the collection and reevaluation of published or old unpublished research results. In the process special attention was paid to the precise date and location of structures and artefacts.

One collection in particular has been studied in depth. This belonged to Mr and Mrs Cools-Mortier who, between 1960 and 1980, built an important collection of finds and photographs, supplemented by oral information provided by Mrs Mortier. This is a very valuable source of information for the Raversijde beach site. Any archaeological structures in the photographs were identified and, whenever possible, roughly located. The collection of finds and

the accompanying documentation have been completely inventoried and made available on the A2S Geoportal.

The exact location of traces of archaeological sites posed a particular problem, not just due to imprecise registration or the loss of research data, but also because the beach provided us with very few exact reference points. Therefore, oral information, a few general location maps and information from the photographs needed to be combined to enhance our understanding.

Nonetheless, additional fieldwork was inevitable in order to further improve our knowledge of the site. Since excavations are not appropriate in these field conditions, various geophysical methods were used. As the study is still in progress, we restrict ourselves in this article to the preliminary results of the surveys of 2007-2012 (Missiaen, 2010; Delefortrie *et al.*, 2012).

On the basis of the desk-based study, a zone was defined for further investigation between two groynes at kilometre markers 24 and 25. Different techniques were used in this zone, both on land (at low tide) and at sea (at high tide): seismic-acoustic measurements (at sea), electromagnetic measurements and coring (on land).

In 2007 seismic-acoustic measurements were conducted. A parametric echosounder emits two signals of different





↑ Network of seismic-acoustic measurements from 2007 and 2010 (BE). © Missiaen, 2010

← A small selection of pilgrim souvenirs and secular badges from the extensive Cools-Mortier artefact collection (BE).

© H. Denis/Onroerend Erfgoed/A2S

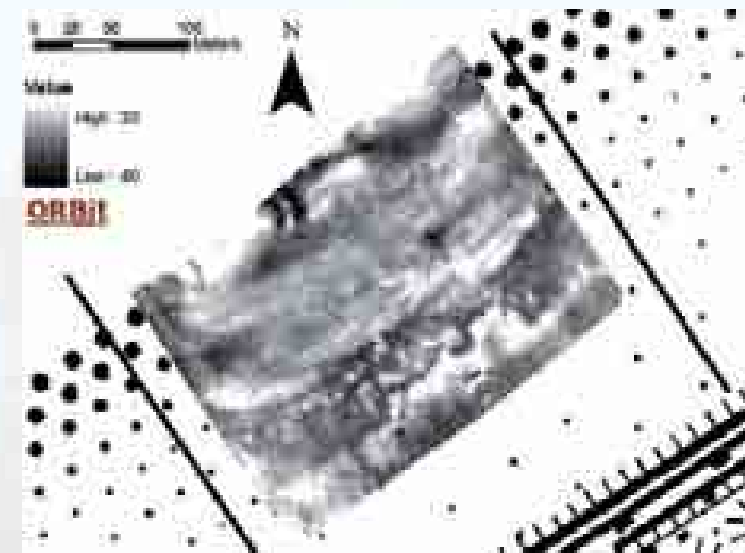

↑ The measured zone between the groynes and the variation in apparent electrical conductivity up to a depth of about 0.5m (BE). © Orbit/A2S

A DUALEM-21S soil sensor pulled by an all-terrain vehicle on the beach (BE). © K. Vandevorst/Onroerend Erfgoed/A2S



Coring by means of Van der Staay suction-corer on Raversijde beach (BE). © Kris Vandevorst/Onroerend Erfgoed/A2S



• • • frequencies to the sea floor. The seafloor relief was mapped by means of a high frequency pulse (100 kHz), while a low frequency pulse (between 6 and 14 kHz) reveal a crossed section of the underlying structures.

On the basis of these measurements, several fossil tidal channels could be charted in a large area off the coast of Raversijde. The study was continued in 2010, resulting in a smaller-scale yet more detailed image of the intertidal zones (Missiaen, 2010).

A complex system of intersecting fossil tidal channels was detected as well as a more recent channel, parallel to the current shoreline. This may be part of an old dyke damming a tidal gully. A network of smaller channels was located between the groynes. Irregular and often interrupted structures covered by 1m of sediment were detected at a distance of 142 to 178m from the current seawall. These are probably settlement traces that were still on the surface 40 years ago. Further seismic recordings have been planned in this zone to better understand these complex traces and to correlate them with the electromagnetic measurements (research ongoing during editing of this report).

Electromagnetic induction measurements were carried out in the intertidal area as well. The test zone measured an area of 500m<sup>2</sup> in 2010 and was expanded to approximately 6ha in January 2012. The research was conducted by means of a DUALEM-21S sensor, which measures both the apparent electrical conductivity (mS/m) and the apparent magnetic susceptibility (dimensionless) using a configuration of four coils, each with a different depth sensitivity of up to 3m below surface level.

Two test zones were subjected to measurements in 2010. This revealed that variability was significant, despite the considerable background noise resulting from the high conductivity of salt-rich sediments. Led to the conclusion that electromagnetic induction is a valid technique for detecting structures in the subsoil of sandy beaches.

Several remarkable traces were found in 2012:

- A zone with clear structures was perceptible at a depth of less than 0,5m over a surface area of approx 120x70m and 120m distant from the current seawall. Because of their regular structure, they may be identified as peat extraction pits or the remains of dwellings.
- Peaks in the measured values may indicate the presence of metal objects in the soil.
- A zone with linear structures perceptible at a depth of less than 1m. It is unclear whether these structures have a human or a natural origin (possibly prehistoric channels).

In March 2012 an area of about 3.5ha adjacent to the zone already studied and closer to the seawall has been charted, and the zone with possible traces of human activity was measured in greater detail together with the edge of the current dyke foundation with a DUALEM-1S sensor.

To link the geophysical observations to the subsoil conditions, six test corings were conducted in 2010 in the same zone between the groynes, four within the seismic measurement area and two within the electromagnetic measurement area. For this purpose, a Van der Staay suction-corer was used, which prevents

water-saturated sediment from instantly running from the core tube thanks to a suction system. The presence of nearly impenetrable layers of clay made this a very labour-intensive job. The corings, reaching a depth of 4.8m, clearly showed that the strong seismic-acoustic reflectors correspond to shell-rich layers, layers of clay and peat, and transitional layers between clay and to sand.

## Conclusion

This study of Raversijde beach has produced numerous results. The collection and processing of old research data has greatly increased our knowledge of the site which, in turn, laid the foundation for the fieldwork. In addition, the collections of finds and photographs formed an important contribution to the maritime database linked to the A2S Geoportal. This site also offered an excellent opportunity to experiment with different geophysical survey techniques.

The geophysical results were ground-truthed on the basis of a small number of cores, but the technique of coring in water-saturated sediment needs to be fine-tuned. In the future, a network of cores will help to develop an optimum strategy for intertidal areas, to interpret the geophysical results and identify and date man-made structures.

Unique multidisciplinary cooperation between different research institutes was established. Techniques for pedological, geological and archaeological purposes complemented each other. Although additional research data is still awaited preliminary results seem promising, as there is a high probability that several man-made structures have already been identified. ■

## References

- Chocqueel, A. (1950). *Les civilisations préhistoriques & anciennes de la Flandre Occidentale d'après l'examen d'objets leur ayant appartenu*. Brussels: Les éditions du temple, 121 p.
- Delefortrie, S., Sacy, T., Van Parys, V. & Van Meirvenne, M. (2012). *Geofysisch onderzoek d.m.v. electromagnetische inductie te Raversijde. Eerste verslaggeving – 08 februari 2012*. Ghent: UGent, 8 p. [unpublished research report]
- Gevaert, G. ed. (2007). *De archeologische site 'Raversijdestrand'. Academische zitting over maritieme archeologie. Raversijde, 6 november 2007*. Brussels: Flemish Heritage Institute, 38 p.
- Missiaen, M. (2010). *Acoustic imaging offshore Raversijde. Results of the 2nd survey, April 2010*. Ghent: UGent, 20 p. [unpublished research report]
- Pieters, M., Demerre, I., Lenaerts, T., Zeebroeck, I., De Bic, M., De Clercq, W., Dickinson, B. & Monsieur, P. (2010). *De Noordzee een waardevol archief onder water. Meer dan 100 jaar onderzoek van strandvondsten en vondsten uit zee in België: een overzicht. Relicta*, 6, pp. 177-218.
- Thoen, H. (1978). *De Belgische kustvlakte in de Romeinse tijd. Bijdrage tot de studie van de landelijke bewoningsgeschiedenis. Verhandelingen van de Koninklijke Academie voor Wetenschappen, Letteren en Schone Kunsten van België*, XL(88). Brussels: Royal Flemish Academy of Belgium for Sciences and the Arts, 255 p.



# Biéroc-la-Mondrée

## a Middle Paleolithic site

The survey conducted in July 2010 on the Biéroc-La-Mondrée in Fermanville (Manche, France) has provided a complementary evaluation meant to better comprehend the site in its environmental and chronological contexts.

By Alexandre Poudret-Barré, Garry Momber, Dominique Cliquet, Jean Olive, Joë Guesnon and Norbert Mercier

The site which lies 20m under water at the bottom of the Biéroc-la-Mondrée cliff, near Fermanville, is thought to be older than the latest Ice Age, i.e. between 40,000 and 70,000 years. Excavations in the 1970s brought to light more than 2500 knapped flints, most of them waste flakes highly typical of the Levallois technique. They testify to a Neanderthal occupation on the continental shelf during the last interglacial/beginning of the last Ice Age, which means that the Biéroc-la-Mondrée site is the most ancient submerged site in North-West Europe. Diving operations, however, were only recently organised (between 2000 and 2002) to determine the general extent of the site, characterise the site's environment, identify the occupation period(s), and finally, to try to understand the taphonomical phenomena which the site has undergone.

### Underwater survey

In partnership with the 'Service Régional de l'Archéologie de Basse-Normandie' and the divers of ASAM-Cherbourg, the A2S team surveyed the site between 26 and 30 July 2010. On board two semi-rigid boats, 8 divers performed 60 dives, totalling 42 hours under water. Following visual survey of the site, the divers planted reference points and laid a triangular grid allowing accurate positioning of the trial excavations made in 2002.

Reconnaissance dives on site confirmed discrepancies in the makeup of the seabed, including silty sand, cobbles, boulders and outcroppings of indurated clay and rock. Discrepancies in the distribution of artefacts were also observed, with a greater concentration in the southern part of the site, containing thicker sand deposits. In total, 341 artefacts were recorded along the five baselines covering a nearly 350m<sup>2</sup> wide area into a wider, nearly 40,000m<sup>2</sup> large, zone. Ninety per cent of the artefacts recorded by the divers were found in the southern half of the site.

Relatively high thickness and looseness of the sedimentary deposit south of our grid suggest that a basin or channel might exist, where sediments could have been trapped. The presence of knapped flints, in close association with the deposit and the pollen sequence, suggests that this may be a primary deposit (Clet *et al.*, 2003).

Although there is no evidence that the clay may be the initial archaeological layer, the boundaries of this paleostructure could lie 30m east where a clay layer is outcropping. Our hypothesis was that the basin or channel bed substrate was probably resistant or sheltered enough to withstand environmental and hydrographical changes for several tens of thousands of years.

A site map was drawn by means of a side-scan sonar analysis of the deposit, confirming the differences in sedimentation between the northern and southern parts of the site, as well as the proximity of the paleo-cliff to the site.



Biéroc-la-Mondrée site plan (FR). © ADRAMAR/HWTMA/A2S

### OSL dating

A core sample of the sediment was taken along baseline 7 to attempt dating of fine sediments using the quartz OSL technique (Optically Stimulated Luminescence). The sequence taken contains, from top to bottom: 21cm of organic silty sand related to the lithic industry, 23cm of sand and 16cm of grit. The preliminary results obtained by the Bordeaux Laboratory confirmed the hypothesis that the top part of the site was occupied at the junction between isotopic stages 5a and 4, i.e. around 70 000 years b.p. (Mercier *et al.* to be published), which is consistent with pollen data (Clet Pellerin, 1988).

The interpretation of the geological and sedimentary matrix linked with the paleo-surfaces made it possible to assess the archaeological potential of the buried soils. The increasing thickness of the sand and silty material layer towards the southern part suggests a greater sedimentation and less water movement while the clean surface of artefacts in that zone suggests a mild abrasion effect, preventing colonisation by marine organisms. It is therefore essential to understand the relationship between the sedimentation and the

### References

- Clet, M., Cliquet, D., Coutard, S. & Olive, J. (2003). *Fermanville (50). Anse de la Mondrée/Biéroc. Rapport d'opération 2002*. Caen: SRA Basse-Normandie, 24 p. [unpublished research report]
- Clet, M. (1988). Étude de séquences marines interglaciaires en Normandie corrélables aux stades isotopiques 7 et 5. In: *Actes X<sup>e</sup> Symposium APLF: Palynologie, Ecologie, Paléocologie, Bordeaux, 1987*. Pondichéry: Institut Français de Pondichéry, Section Sci. et Tech., 25, pp. 151-168.
- Cliquet, D., Coutard, S., Clet, M., Allix, J., Tessier, B., Lelong, F., Baltzer, A., Mear, Y., Poizot, E., Auguste, P., Alix, P., Olive, J. & Guesnon, J. (2011). The Middle Palaeolithic Underwater Site of La Mondrée, Normandy, France. In Benjamin, J. et al. (eds). *Submerged Prehistory*. Oxford: Oxbow Books, pp. 111-128.
- Coutard, S. & Cliquet, D. (2005). Chronostratigraphie des formations pléistocènes et peuplements paléolithique en contexte littoral (Val de Saire, Normandie). *Bulletin de la Société Préhistorique Française*, vol. 102, n° 3, pp. 477-499.
- Mercier, N., Cliquet, D., Olive, J., Poudret-Barré, A., Momber, G., Coutard, S. & Clet, M. Approche du gisement paléolithique moyen sous-marin de la Mondrée à Fermanville (Manche) et évaluation de son potentiel en matière de datations par la méthode de l'OSL. In *Actes du colloque HOMER, Vannes, 2011*. (to be published)
- Momber, G., Cliquet, D., Poudret-Barré, A., Millership, V. & Binoc, R. (2010). *Rapport d'expertise du site de Biéroc, Juillet 2010*. Domagné: ADRAMAR, 48 p. [unpublished research report]

accumulation of sediments in a zone with a 'fresh' industry lying at the bottom.

It should be noted that the site lies on the western side of a bay more than one kilometre wide, in front of a floodplain today lined with a sand beach. The plain lies below a V-shape incised valley which cuts through the hills from the south. The paleo-channel or basin probably had connexions with this ancient hydrographical network. Therefore, the underwater course of the paleo-channel should be followed to determine how it relates to the archaeological deposit as this may yield information on the size of the paleo-channels which are likely to contain archaeological material.

### Conclusion

Data from the 2010 survey revealed the character of the site which will serve as a basis for planning future operations. The boundaries of the site have not been resolved. The most likely hypothesis is that the sand deposit containing the stratified archaeological level(s) is a filling material having accumulated in a protected basin or on the shores of a paleo-channel. Accordingly the exact area of the archaeological site is yet to be determined. Future prospection should use geophysical survey to define parameters. This should be conducted before further intrusive sampling or excavation is undertaken as this could destabilize areas of the site or undermine the archaeological integrity of the results. ■





Sample being lift from Bouldnor Cliff site (UK). © M. Pitts

## Training and cooperation

The sheltered waters of the Solent have enabled diving archaeologists from all partner organisations to work closely together at Bouldnor Cliff. The team have been able to share ideas and learn the skills necessary to work on similar submerged landscape sites.



© HWTMA/A2S

## Media

Work on the Bouldnor Cliff site as part of the A2S project has resulted in new discoveries and created a great deal of interest in the media. It has been the subject of a documentary, two news reports, two local radio interviews, seven articles in the press and hundreds of web features.



© HWTMA/A2S

## Geophysical anomalies

Anomalies identified within a geophysical dataset revealed many more remnants of the submerged landscape in the Solent. These anomalies were systematically dived and inspected by A2S team members. The data was analysed by the University of Southampton as part of the A2S project, while in the UK, data is held by the UK Hydrographic Office (UKHO).

# Mesolithic industry below the Solent shores

During glacial periods water levels has been over 120 m lower than today and many hundreds of kilometres further offshore. This exposed a vast landscape that offered opportunities to our ancestors and contained areas rich in resources that were available for exploitation.

By Garry Momber

There were periods when the UK was a physical part of a larger European land mass and there were times when it supported an early European population. But the coastline was dynamic and forever changing. During fluctuations in global temperature sea levels rose and drowned low-lying coastal plains. Terrestrial features in sheltered areas were protected by marine sediments. Where sites survived beneath these, they have the potential to tell the story of changing environments and of the people who lived in them.

Examples of submerged landscapes can be found across the Atlas of the 2 seas region. They include the 70,000 year old site at Cape Levi, off Fermanville, the inundated coastal Medieval villages of Raversijde and the drowned occupation areas of the Solent. The site which we will focus on here is the occupation site below Bouldnor Cliff that dates back over 8,000 years. It lies 11m below British Ordnance datum in the Solent.

## Submerged prehistoric activity

Occupation of the area initially occurred in a basin that supported a fresh water wetland and possibly lakes. These conditions continued until sea level rise covered the land. It has been the source of stratified lithic assemblages, but more significantly, over 20 pieces of worked material have been recovered from a single feature which appears to sit on an area of small-scale industrial activity. The hypotheses is enhanced by the discovery of the UK's oldest pieces of prepared string, wood chippings, carbonised wood (subsequently worked) and deliberately deposited stores of flints which were heated to exceptionally high levels. The evidence suggests this may have been a boatbuilding site where a dugout canoe or logboat was made (Momber et al. 2011).

Assessment of the timbers revealed sophisticated woodworking. One piece in particular, which provided a secure radiocarbon date of 6370-6060 cal BC (BETA-249735), has been tangentially split

from a large oak tree approximately 2m in diameter. The timber would have been of sizable proportions, possibly in the order of 10m long. Later prehistoric evidence indicates that this technique was used to produce logboats and for the construction of monumental structures.

## A2S discoveries

In 2010 and 2011 support from the European Regional Development Fund through the INTERREG IVA 2 Mers Seas Zeeën Cross-border Cooperation Programme enabled the work to continue. The objectives were to determine the extent of the worked timbers to help with the interpretation of the assemblage, to investigate geophysical anomalies that had been identified in geophysical datasets and monitor the loss of this relict common European landscape. While addressing the archaeological aspects of the project, an underlying agenda was to share our experiences with members of the A2S team and to train volunteer divers.

During the fieldwork, further inter-related pieces of worked oak were uncovered, including two long curved pieces. These were 0.95m and 1m long respectively and they both had been worked with longitudinal grooves. Another piece of timber, that appears to be the worked end of a logboat, was recovered. This would have been part of a larger timber that had suffered damage around the time of deposition. There is evidence of burning and degradation around the edges of the timber pieces while some cut marks remain well defined and clear.

## Conclusion

The rich archaeological material from the settlement on the edge of the basin contrasts with the scarcity of Mesolithic occupation sites in the wider region, suggesting that the lowland basin below Bouldnor Cliff was a focal point offering attractive settlement opportunities. The work is still in its evaluation stage, yet it has already uncovered artefacts the like of which are seldom seen on British Mesolithic sites. Furthermore, the wetland or lacustrine environment that once existed in the Western Solent, would have been rich in resources that could have been exploited all year round. Therefore, the concentration of Mesolithic material at Bouldnor Cliff may suggest an increased element of sedentism.

Bouldnor Cliff is currently unique but represents an example of what may remain buried at many similar locations between Britain and Continental Europe when the land was joined. It is rich in well-preserved organic material and is likely to add extensive detail to the current Mesolithic archaeological record. During the course of the A2S the work has been published in two academic papers and as a large book. ■

## Reference

- Momber, G., Tomalin, D., Scaife, R., Satchell, J. & Gillespie, J. (2011). *Mesolithic occupation at Bouldnor Cliff and the submerged prehistoric landscapes of the Solent*. York: Council for British Archaeology Monograph, Series Research Report 164, 197 p.



# Shipwreck research and investigation

One of the main objectives of the A2S project was to enhance our understanding of the submerged cultural heritage in the waters between the partner nations. This case study will look at a selection of shipwrecks that have been identified as important and have warranted further investigation.

By Lauren Tidbury

The method used during desk-based research was first to collate a database of shipwrecks and known losses. It involved assessing the existing corpus of work to understand the current state of knowledge as well as identifying any gaps. This stage in the research included the collation of existing documentary, graphic, photographic and electronic information in order to identify the likely character, nature, extent and quality of the known or potential heritage assets in a local, regional, national or international context, as appropriate. The end result of this process was the identification of 894 shipwreck sites. Many of these sites are well known and located with a long history of archaeological investigation. Other sites are located but contain little or no baseline information. Finally, some sites are only historically documented and their location is yet to be discovered.

The wrecks were then reviewed to identify those that had the potential to tell us more about our common European past, to provide information about little known periods or aspects of our heritage, or because wreck sites were under threat. The importance of these losses lies in their ability to help build a picture of cultural links. They are time capsules that reflect social interactions at a fixed point in the past. The most significant wrecks were selected for further research.

Of the 894 sites identified, 46 shipwrecks were chosen as having

the potential to add relevance to the A2S project. Desk-based research into each wreck was extended to produce individual reports. Sources of information scrutinised included the *National Monuments Record*, the UK Hydrographic Office, information from the Receiver of Wreck, national archives, local archives, as well as French and Belgian archives where possible. Alongside this, information was gathered from contact with individuals and groups such as local dive clubs and local historians. The reports were designed to cover information on the vessel's history, the known archive and to highlight the potential for further research.

The results of this staged approach to the research, the level of significance and amount of information available informed our next levels of investigation which included: further targeted geophysical survey, fieldwork, archive research and photography of artefacts. The work was carried out in order to enhance our understanding of these sites, looking to answer specific research questions based on the aims and objectives of the A2S project (see pages 22-25).

Two examples where investigation and research have enhanced our understanding, are the *Stirling Castle* and the *SS Azemmour*. The *Stirling Castle* has a long history of investigation, with over 30 years of archaeological and archive research. The *SS Azemmour* on the other hand has comparatively little and there is still much to be done.



↑ Historical photo of the *SS Azemmour*, a triple expansion steam ship (UK). © D. Wendes

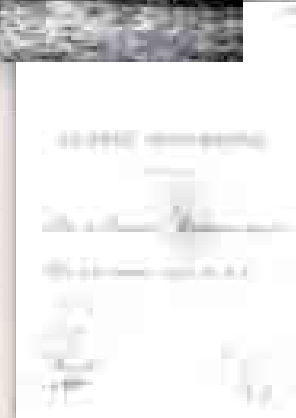

↑ Historical document found in the French Archives during research on the *SS Azemmour*, a steel freighter built in Britain and sold to a French company. The ship was torpedoed by a German U-Boat during World War I. ©HWTMA

↑ Engraving of the 'Great Storm' in 1703 which resulted in the loss of many ships and thousands of lives, thirteen Royal Navy ships were lost including the *Stirling Castle*. © Unknown author

↑ Photographs of the *Stirling Castle Muster Book*, located in the National Archives. Resources such as this can provide information on who was on board the vessel for certain voyages as well as dates of voyages and even crew wages (UK). © HWTMA

## A long history of seafaring

Evidence for seafaring along the English coast of the 2 Seas zone can be traced as far back as the Bronze Age. Meanwhile, scatters of coins at the Needles suggest the presence of a Roman shipwreck in the area. Over time, the inter-tidal zone of the Solent has preserved evidence of Saxon logboats while historical sources record the loss of a Viking war fleet. In the post-medieval and modern period, the remains of the *Mary Rose*, perhaps England's most famous piece of maritime archaeology, can be listed alongside men-of-war, clipper ships, submarines and aeroplanes.



© National Archives (UK)

### Stirling Castle

The *Stirling Castle* was a third rate 70 gun ship of the line built by John Shish and completed in two years, being launched at Deptford on the south bank of the river Thames in 1679. At 1,114 tons the *Stirling Castle* was slightly larger than the average third rate as laid down in the specifications of the 1677 ship building programme. It was amongst the third rates listed in the Revolution Fleet of 1688. During 1699 the ship was rebuilt, and in 1701 was refitted and re-commissioned back into the Navy. The career of the ship came to an end in the early hours of 27 November during the Great Storm of 1703. The ship was wrecked on the Goodwin Sands, losing four fifths of its crew. The storm also claimed two other thirdrates in the same fleet, *Northumberland* and *Restoration*. In 1980 the *Stirling Castle* was designated under the Protection of Wrecks Act 1973.

The wreck was discovered in 1979 and has a long history of investigations. This has resulted in a large archive, including historical documents and paintings, as well as several hundred artefacts that have been recovered from the site, photographs, under water video footage, site plans and drawings. The HWTMA has been involved in the audit and assessment of the *Stirling Castle* archive. The wealth of archive information has allowed for a better understanding of the site and its relevance at local, regional and international levels, and more importantly it will enable us to understand the *Stirling Castle* as a social product of its time.

### SS Azemmour

The *SS Azemmour* was a steel freighter built in Britain in 1909, powered by a triple expansion steam engine. The vessel was originally named *Wistaria* but in 1913 was sold to the French Compagnie Generale Transatlantique and renamed *SS Azemmour*. In March 1918 the vessel was hit by a torpedo from the German U-Boat *UB-59* and sank approximately 24km south west of the Isle of Wight. Primary research has been undertaken by Mr David Wendes, a local maritime historian who has carried out extensive archival research on the vessel. It has been complemented by information provided by DRASSM through the A2S project from the French archives, as well as archival information relating to the sinking of the vessel found in the British National Archives. The vessel's identity was confirmed by crockery recovered from the site. Diving activity carried out for the A2S project has aimed at confirming the position, extent, stability and character of the site. ■

### References

- HWTMA (2009). *Stirling Castle: Archive Summary Report*, 45 p.
- Wendes, D. (2006). *South Coast Shipwrecks*. Eastleigh: David Wendes, pp. 180-181.



→ Survey grid over the site (FR).  
© T. Seguin/  
ADRAMAR/A2S

← The research vessel Hermine-Bretagne moored on the site (FR).  
© T. Seguin/  
ADRAMAR/A2S

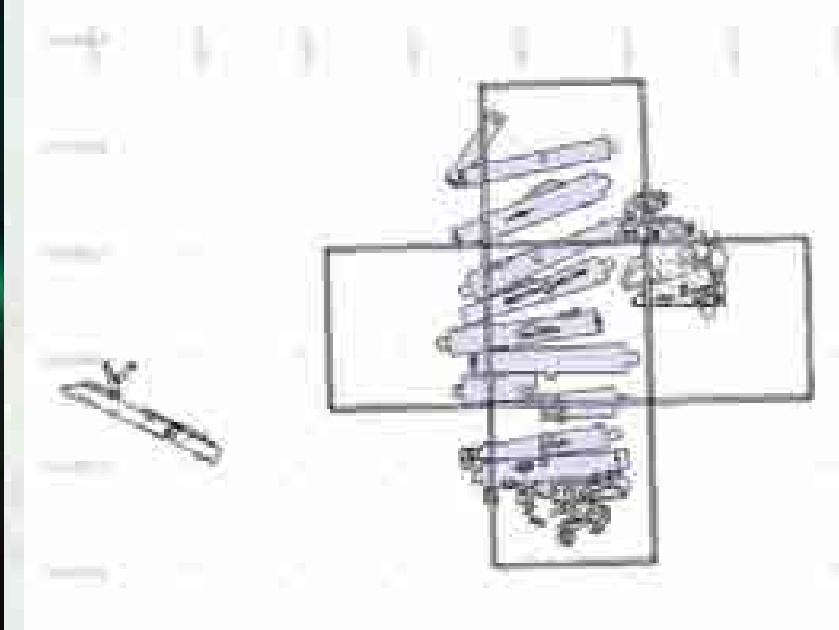

↑ ZI 24 site plan, showing the cannons and the grid (FR). © ADRAMAR/A2S

# Excavation of the ZI 24 shipwreck alleged to be the *César*

ADRAMAR's archaeological operations on the ZI 24 wreck site was an opportunity to compare underwater survey methods, to further analyze the site through excavations, and to carry out archival research. Excavation revealed stone ballast and remains of the hull, providing evidence that a wreck was lying underneath the eleven cannon.

By Alexandre Poudret-Barré, Anne Hoyau-Berry, Yann Gaonac'h, François Lang, Erwan Marion and Damien Sanders

## History of the investigation

The ZI 24 wreck lies on a sandy-silt seabed, 18m below sea level at high tide and upstream of the Rance tidal power station dam. The site was reported on 9 October, 1989 by Loïc Martin and an archaeological survey was made during the *Carte Archéologique du littoral atlantique* in 1996. The remains were recorded, measurements and the orientation of the cannon were taken, and timber and flints were noted (L'Hour 1997, p.59). The site consists of an alignment of eleven cannon of a similar size lying next to one another in a head-to-tail position. This pattern is an indication that they were not in operation but were more likely to be part of the cargo or used as ballast.

Although the archaeological survey showed the site dated between the second half of the 17<sup>th</sup> century and the end of the 18<sup>th</sup> century, several uncertainties still remained. Were the cannon used as ballast or were they the ship's cargo? Similarly, were the flints used as ballast or were they part of the River Rance's natural bed? Was it possible to establish a historical relationship between the wreck and the *César*? Was archaeological material to be found on site?

Geophysical survey, archaeological excavations and archival research was conducted in 2011 to address these issues.

## Archaeological operations

The site's geographic coordinates were refined through side-scan sonar analysis, which also made it possible to assess the extent of siltation since the initial discovery in 1996. Unfortunately, analysis using a sub-bottom profiler did not yield the expected information which would have been used to set-up excavation pits based on the site's stratigraphy. This initial operation, however, was an essential step in the preparation and completion of the archaeological survey especially for establishing a mooring plan for the research vessel *Hermine-Bretagne*.

Although access to the ZI 24 wreck site was not easy, archaeological investigation was eventually found to be possible. But, due to its closeness to the Rance's dam, special diving safety procedures were implemented. The purpose of the survey was to compare the 'standard grid' survey method and the *direct survey method* (DSM) for the underwater recording of data, to measure and study the cannon, to make excavation pits and identify the stone found on site.

The comparison between the 'standard grid' and the DSM showed that both methods could be performed quickly and that they produced high-quality results. The DSM additionally yields three dimensional data based on a single recording of measurements, but it requires a graphical survey of the site to provide a context for

the survey points. This can be made either through the 'standard grid' survey method or through a form of surveying independent of the grid.

The cannon have a cascabel and overall elongated appearance which is indicative of 17<sup>th</sup> century artillery pieces. They feature fairly homogeneous dimensions which would confirm that they were the ship's cargo. Although they could be 18-pounders bore diameter cannons manufactured in France, the possibility that they were foreign and made elsewhere in Northern Europe cannot be dismissed.

The excavations provided evidence that the initial archaeological hypothesis was wrong. The discovery of architectural pieces in excavation pits 1 and 4 was an indication that the ZI 24 wreck is oriented lengthwise on an east-west axis, perpendicular to the layout pattern of the cannon. The stone layer lying under the sand was found to be the wreck's stone ballast rather than a part of the natural river bed.

## Archival research

The purpose of the documentary research was to collect and summarize any available information regarding the *César* and its wrecking in order to find similarities between the archaeological site and the ship's history. The *César*, which was chartered by the King and was loaded with cannon, sank on 6 March 1692 in the Belle-Grève roads. The archival sources mostly contains the proceedings of the trial of Guillaume Raguene (captain of the *César*) versus Simon Masson (coastal and deep-sea pilot) and the correspondence between the Saint-Malo 'Marine commissioners' and the 'Ministry of Marine' concerning the wreck and the rescue and related recovery and disassembly operations. Our investigation also involved collecting information on the site's geographic environment in modern times, including a study of old nautical maps of the Saint-Malo area.

## References

- L'Hour, M. (1997). *Épave de la Rance, dite de la ZI 24 (Ille-et-Vilaine). Bilan Scientifique du DRASSM*. Marseille: Ministère de la Culture et de la Communication, p. 59.
- Poudret-Barré, A. ed. (2012). *L'épave de la ZI 24 (La Richardais). Rapport d'opération 2011*. Domagné: ADRAMAR, 2 vol., 109 p. & 107 p. [unpublished research report]

## Could the ZI 24 wreck be the *César*?

The site's geographical location, the layout of the cannon and archival research seem to confirm the hypothesis that the ZI 24 wreck is most likely to be the *César*. However, one should be very cautious as no archaeological evidence is available so far to define a more accurate site chronology, or indeed confirm whether the cannons were used as ballast or were part of the cargo.

Besides the issue of identifying the wreck, further excavation works would allow us to investigate various lines of research orientations:

- confronting submarine measurement methods;
- studying the method for loading cannon, either as ballast or cargo;
- studying the wreck's naval architecture in order to determine what kind of ship it is;
- collecting dendrochronological samples;
- studying the stone ballast layout pattern, its stratigraphy and composition;
- studying the stone ballast from a mineralogical point of view in order to determine its origin;
- studying the impact of the recovery of the cannon on the site's taphonomy.

These investigations have proved to be particularly interesting as only limited research has been conducted regarding the layout, the geographic origin and the stratigraphy of stone ballast in ships. The collaborative analysis of the sediment, the ballast and the measuring methods initiated in 2012 are providing definitive answers to some of the longstanding questions associated with the site which will open up yet wider research perspectives. ■



→ HMS Wakeful.  
© HMS Wakeful archives,  
J. Samyn.

# HMS Wakeful

a wreck recorded on site with an interest common to the project partners

An English ship, departing from France and sunk in Belgian waters, the wreck of the destroyer HMS *Wakeful* forms a link between the three project partners' nations. During archival study and field research, the partners worked closely together to gather new information.

By Inge Zeebroek, Ine Demerre and Pieterjan Deckers

## Introduction

HMS *Wakeful* (H88), a British destroyer with a length of approx 100m, was hit amidships by a German torpedo on 29 May 1940, during the evacuation of Dunkirk. The ship broke in two near the engine room and sank very quickly (Termote, 2009). Only a few of the 640 soldiers and 98 crew members were rescued (Johan Samyn, pers. comm.). The ship was wrecked near the Akkaert Bank, in the middle of the current shipping lane, 12 nautical miles north of Ostend. Nowadays, the wreck is protected by the British War Grave Commission. Nevertheless, as it posed a danger to sea traffic, the highest wreck parts were removed to clear the channel after registration of the site in 2003. A Royal Navy ship that left France and now rests in Belgian waters is an obvious research object within the A2S project. Further questions arose during this study: how should we deal with this kind of recent nautical heritage? What is the added value of archaeological research on such wrecks?

Wrecks from both world wars are often neglected in archaeological research due to their young age (L'Hour & Veyrat, 2005). On the other hand, sport divers are only too happy to collect 'souvenirs' from recent war wrecks. In addition, their history still lives on in the memories of survivors and their relatives.

Because of its importance as a war grave and its limited accessibility, the state of preservation of HMS *Wakeful* remains a pressing question nearly 10 years after the intervention in 2003. The wreck needed a detailed archaeological screening. Thanks to the project's international dimension, various recording techniques could be compared and collaborators from the three countries could exchange expertise.

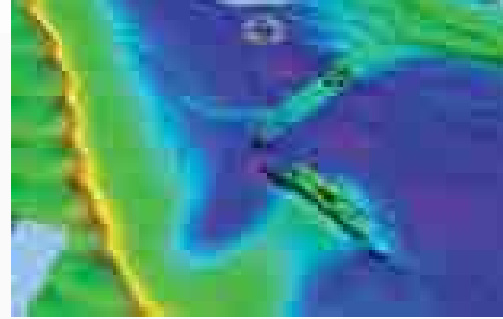

↑ Multibeam image of the HMS Wakeful (BE).  
© Agency for Maritime and Coastal Service -  
Department of Coast - Flemish Hydrography, 2006



↑ A gun barrel on the aft part of the ship. Due to the extremely limited visibility, photographing the wreck proved difficult (BE). © D. Damen/Onroerend Erfgoed/A2S



Detailed sketch of  
HMS Wakeful based  
upon the on-site  
measurements  
of 2010-2011 (BE).  
© Onroerend Erfgoed/A2S

## Preliminary survey

Prior to the diving campaigns, reports describing the state of the wreck at various moments in the past were studied. A 1988 diving report revealed that the fore part and the aft part were located at right angles to one another on the seabed. Boilers, funnels, propeller, guns and other parts of the wreck were well preserved and protruded up to 4m above the sea floor.

In 2001-2002 the wreck was surveyed by the former department 'Waterwegen en Zeekanaal' by means of bathymetry, magnetometry, side-scan sonar and diving surveys. Subsequently, the highest located wreck parts (< 20m below MLLWS) were removed and deposited next to the wreck to clear the shipping lane.

The propeller was not located during this survey. The visible metal of deck plates, ribs and shell plates were in bad condition and stuck up to 2m above the sand. Two guns were in position on the afterdeck. The interior of both the fore part and the aft part was silted up and subject to rapid sedimentological changes. Ammunition and pieces of wreckage were spread round the site. The condition deteriorated even further after the 2002 intervention. A multibeam image from 2006 provides the most recent overview of the wreck, but the level of detail was limited so ground-truthing was deemed to be necessary.

The information from these files was supplemented by English archival research. Various documents from the Public Record Office were consulted, such as the interrogation of Captain Fisher of HMS *Wakeful* and confidential reports concerning the Dunkirk evacuation (*Operation Dynamo*).

## On-site registration

Some 15 dives to HMS *Wakeful* were carried out within the scope of the A2S project. The remains of the ship were mapped by means of a network of fixed points and base lines along and across the wreck. In addition, the wreck was photographed and filmed.

The two parts of the wreck are approximately 15m distant from each other. The 42m long rear part is in an almost upright position. Large areas of decking, the footings for gun emplacements and a guns remain intact. Aspects of the vessel remain cohesive with pieces of superstructure rising 2-3m above seabed level. The most upstanding components are found at the north east extent of the vessel probably containing machinery which suggest it to be the midship area (and thus the broken area of the wreck). Of the hull itself are mainly ribs preserved. Structural elements are covered in fishing nets.

The fore part of the ship is approximately 54m long. The ship's side mainly consists of ribs connected by partly preserved metal plating that projects up to 3m above the seafloor. The ship's bow is largely covered by sand. Only the tip of the bow is still visible. The fore part of the ship's most conspicuous components are two large boilers. In addition, a copper plate with the letters 'WA', fragments of wooden chests and an orange brick with the word 'Glenboig', (a small Scottish town with an important brick industry) were found. In comparison with the observed condition in 1988 and 2001, many wreck parts appear now to be even more affected by erosion and other degradation processes.

## Conclusion

Thanks to the close collaboration between the project partners and an extensive team of experienced volunteer divers, this shipwreck, the history of which provided a link between the three countries involved, was mapped in detail for the first time. The preliminary survey of Belgian research files supplemented with historical data from British archives provided a solid basis for the on-site registration. As with the other case studies, the results of this investigation will be disclosed on the A2S Geoportal. ■

## References

- L'Hour, M. & Veyrat, E. (2005). *La Mer pour Mémoire*. Paris: Edition Somogy et Association Buhez, 396 p.
- Termote, D. & T. (2009). *Schatten en scheepswrakken. Boeiende onderwaterarcheologie in de Noordzee*. Leuven: Davidsfonds, 352 p.



# Flower of Ugie

## turning mystery into meaning

The work of the HWTMA on the shipwreck remains of the *Flower of Ugie* perfectly demonstrates the synthesis of archaeological fieldwork, historical research, scientific analysis and public dissemination created in discovering more about our underwater cultural heritage. The *Archaeological Atlas of the 2 Seas Project* has allowed diving work on the site to continue through 2011.

By Julian Whitewright

The *Flower of Ugie* was first discovered in 2003 when a fisherman snagged his nets on a previously unknown seabed obstruction in the Eastern Solent, off the south coast of England. Initial investigation by the HWTMA revealed an extensive set of wooden shipwreck remains. However, the identity of the wreck remained unknown and the site was named the 'Mystery Wreck'. In order to discover the identity of this shipwreck the HWTMA conducted several seasons of archaeological fieldwork to survey and map the site and to collect detailed information about the characteristics of the shipwreck remains. This included sampling the timber structure to allow dendrochronological analysis as well as species identification. Samples were also taken from a range of the metal fastenings (bolts and nails) and outer hull sheathing, which were subjected to compositional and microscopic analysis.

This work recorded two large areas of wooden structure, each over 15m in length, lying 23m apart and representing the central bottom of the vessel and part of one of the sides. In between was a large debris field of structural ironwork and timbers. The vessel was primarily constructed from oak, ebony and elm. It was carvel built, with iron reinforcement in many areas of the hull, instead of wooden knees. The ship was fastened with a mixture of wooden treenails, copper bolts and yellow-metal (brass) bolts. At the time of sinking, the exterior of the hull was sheathed in yellow-metal. It was not possible to date the vessel through dendrochronology, but comparative analysis of the metal fastenings allowed a provisional date of c.1820-1850 to be assigned.

Throughout the period of fieldwork, researchers at the HWTMA had been compiling historical information to help identify the wreck from over 300 candidates located within a 10km radius of the site. Detailed characterisation of the shipwreck remains allowed comparison between the historical records of shipwrecks and the

physical seabed remains to be conducted, resulting in a positive identification of the vessel as the *Flower of Ugie*. Further historical research was now possible, drawing upon material from the Lloyds Register, Lloyds List and Lloyds Survey Reports as well as contemporary newspapers and documentary sources to build up a biography of the life and career of the ship.

## Vessel Biography

*Flower of Ugie* was a wooden sailing barque, built in Sunderland in 1838 by Luke Crown, a shipbuilder for over 30 years. Between 1838 and 1846 the *Flower of Ugie* engaged in trade with the Indian Ocean. Records of the cargoes of the vessel still survive in the customs books of Liverpool and provide a snapshot of the goods and materials being exported and imported between Britain and India in the late 1830s. This period also included a voyage from India to China in 1842 at the time of the First Opium War between Britain and China. The *Flower of Ugie* seems likely to have been carrying soldiers or supplies. Meanwhile, a period of return voyages between Madras and Mauritius coincides with a sustained period of transport of indentured labour from India to Mauritius in 1844/45. The vessel was sold to new owners in 1846 and was then used on a variety of northern hemisphere routes including the Mediterranean, Baltic and North Atlantic. Destinations included New York, Alexandria, St Petersburg and Odessa. The final voyage of the *Flower of Ugie* ended with shipwreck in the eastern Solent on 27<sup>th</sup> December 1852 while carrying a cargo of coal to Cartagena in Spain. The work of the HWTMA has revealed a great deal about the archaeology and history of the ship; providing an important insight into mid-19<sup>th</sup> century British wooden shipbuilding, as well as illustrating the part played by such vessels in the origins of today's globalised maritime world.

→ An archaeologist from the HWTMA records timber structure on the *Flower of Ugie* (UK). © HWTMA/A2S

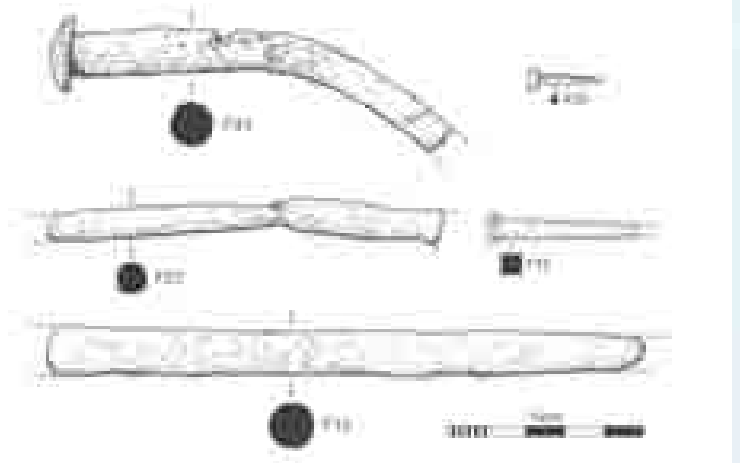

↑ Archaeological recording and scientific analysis of artefacts such as fastening bolts allowed a detailed understanding of the characteristics of the vessel to be developed (UK). © HWTMA/A2S

→ The original Lloyds Survey Report for the *Flower of Ugie* has been located and has provided invaluable information about the original construction of the vessel (UK). © HWTMA/A2S



## Future management

The publication of a monograph report on the archaeological and historical work just described does not mean that the HWTMA's work on the *Flower of Ugie* is complete. Throughout the project, HWTMA has sought to disseminate the archaeological information contained in the shipwreck to the general public. In addition to talks and presentations, HWTMA has created a teaching pack that enables secondary school teachers to use the data gathered during the investigation of the shipwreck to enhance teaching programmes in subjects such as geography, science, maths and history. Finally, the HWTMA has continued to monitor the site of the shipwreck, this was carried out with the help of the A2S project partners during the 2011 fieldwork season, enabling us to share our experiences and train volunteer divers. This has been done through repeat diver observation in conjunction with the installation of monitoring points to provide an indication of any alterations to the seabed sediment. Reduction in sediment levels leads to the exposure of more wooden ship structure. This is subsequently degraded by the combined effects of physical erosion and attack by marine organisms, most notably *Teredo nautilus*. On-going monitoring will enhance our understanding of the processes of exposure, erosion and degradation that are one of the biggest threats to the underwater cultural heritage within the 2 Seas region.

*Flower of Ugie* represents an important part of Britain's maritime heritage. The vessel symbolises the last flowering of large-scale wooden shipbuilding in the leading maritime country of the period. Beyond this, the *Flower of Ugie* gives us an insight into the global trade-routes and patterns of commerce that were the foundation of much of the modern world that we know today. But the vessel is not only about technology and commerce. *Flower of Ugie* was involved in political events with far-reaching consequences and in the organised movement of people, the demographic results of which are still felt today. All of this has been revealed through the careful application of archaeological techniques, deployed in partnership with methodical historical research and disseminated through a proven programme of education and outreach. The A2S project has enabled the HWTMA to share ideas and experience from the *Flower of Ugie* with the project partners and to learn the skills necessary to work on similar submerged sites. ■

## Reference

- Whitewright, J. & Satchell, J. ed. (2011). *The Archaeology and History of the Flower of Ugie, Wrecked 1852 in the Eastern Solent*. HWTMA monograph series 1. Oxford: British Archaeological Reports, British Series 551, 112 p.

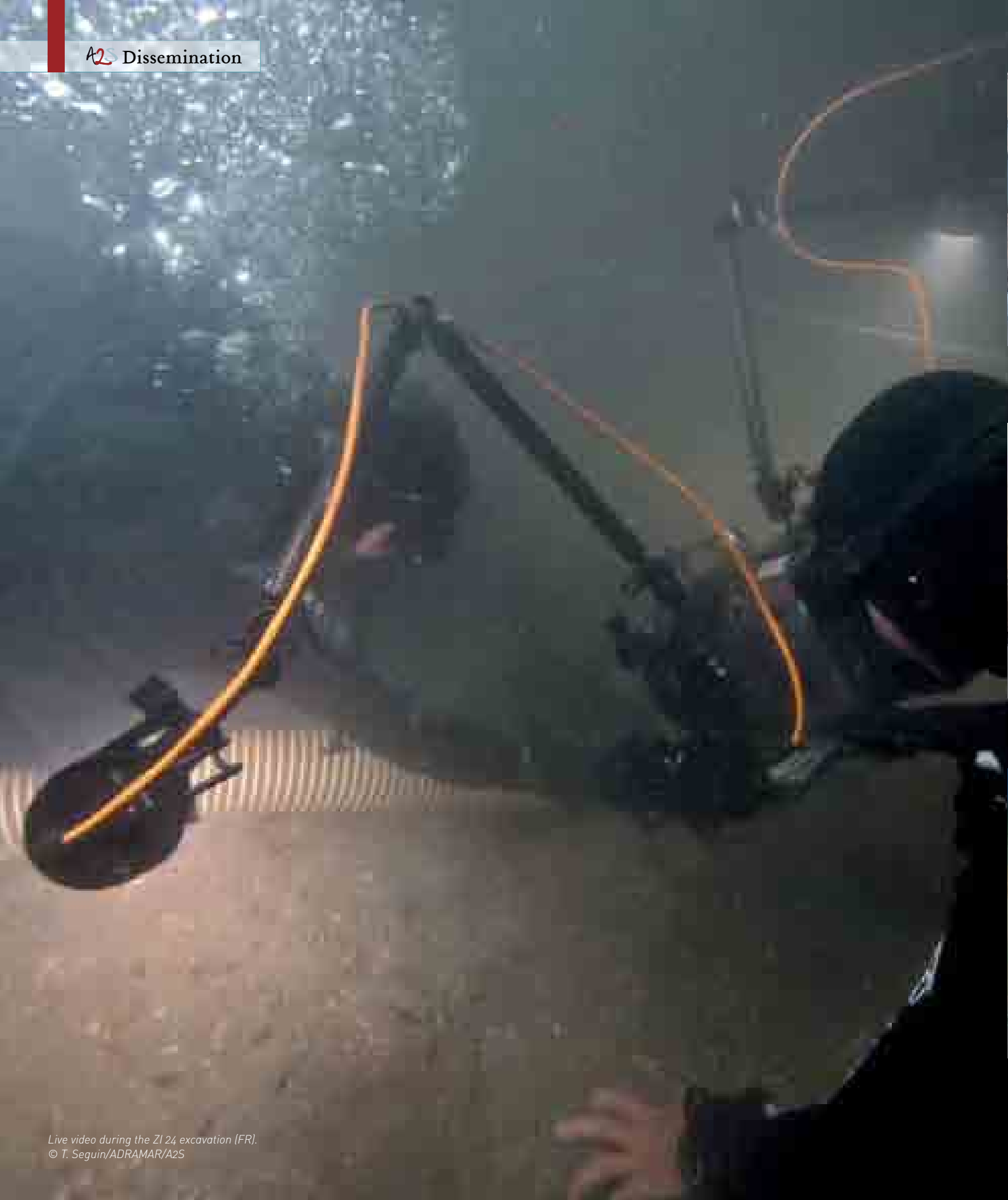

↑ HWTMA's Maritime Bus ready for visitors during the European Roadtrip (FR). © HWTMA/A2S



↑ Interview for the A2S documentary (BE). © Onroerend Erfgoed/A2S

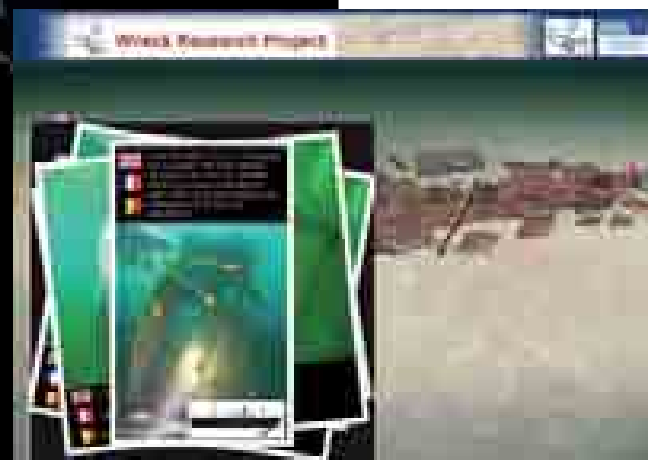

↑ Online 'virtual dive'. One of the resources created in three languages for use in the 3-nation schools project. © A2S



# A2S Dissemination

Dissemination of information collected through the A2S project and making data available to all audiences, has been a core component of the A2S project, from inception to legacy.

**T**he range of audiences the project aims to reach is extensive and varied, including scientists, archaeology enthusiasts, the general public, schools and funders. Recognising challenges and opportunities presented when trying to target such diverse audiences, the A2S project has developed a broad range of methods and approaches incorporating a variety of media.

From a short, amusing stop-motion animation to a 35-minute documentary film, through public events as part of National Heritage Days, articles in popular media, presentations at conferences and seminars, leaflets, brochures, didactic tarpaulins and posters, academic, scientific and popular publications, a 3-nation schools programme with associated resources, a live broadcast from archaeologists working under water, and of course the freely accessible online Geoportal, people with differing levels of involvement, interest and understanding can learn about, and access information from, the A2S project. ■

# A2S Geoportal

The A2S Geoportal offers a comprehensive vision of the marine archaeological landscape by providing unique access to Belgian, English and French data, bringing together the submerged archaeological heritage that we share.

1  
Search



2  
Select

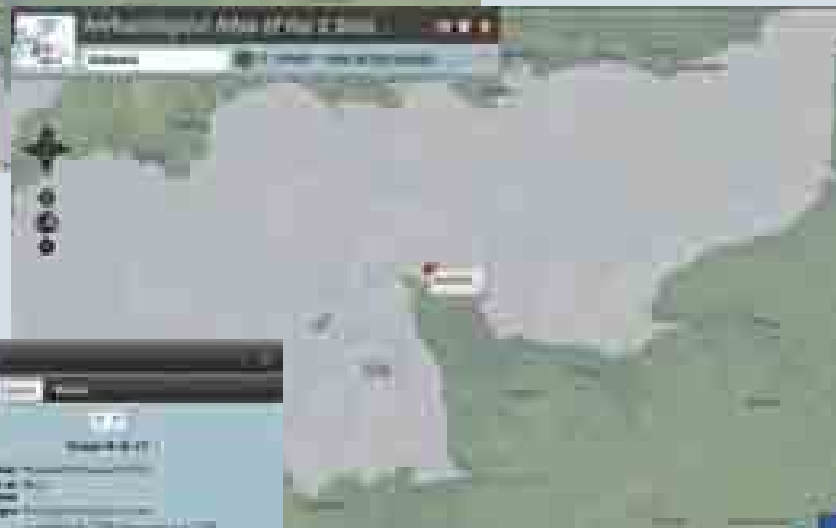

3  
Explore



## Why?

The Geoportal is a key output of the Archaeological Atlas of the 2 Seas project. It provides the means for disseminating information and results, as well as enabling public engagement in the project and encouraging education in the wider field of maritime archaeology and cultural heritage.

## Who?

The Geoportal functions as a research tool for academics, archaeologists, historians and other heritage professionals. It is also available to anyone with access to the internet and who has an interest in marine archaeology and heritage, or just a fascination with historic wrecks.

## How?

The Geoportal has been created by developers from the GeoData Institute at the University of Southampton. The team are specialist in building easy-to-use web mapping applications using open-source technologies, exploiting the latest innovations and open standards of the modern web.

The website can be used easily by anyone who has interacted with a Google-maps style web interface, with simple, intuitive tools for searching the database, exploring wreck records and viewing images and other detailed information.

Photographs, site plans, historic maps and charts and other media are available, helping to further our understanding of the nature and extent of the environment in which sites now exist.

Multiple language support has been built into the Geoportal, so English, French and Belgian users will feel at home straight away.

## Up to date?

The Geoportal embeds its own synchronisation module, automatically connecting to the three-partner databases once a day to find updated and additional wreck records and associated information. No further action is needed by system administrators – as long as the source databases are updated and accessible, the Geoportal takes care of the rest.

## Long term?

The GeoData team have developed the Geoportal using industry-standard open-source software, so in the long term it can be hosted by any suitable service provider, without any software licencing costs or implications.

## Technical info

Over  
**1,573** archaeological sites,  
covering the English  
Channel and Southern  
North Sea

Over  
**3,000** underwater, artefact  
and historical photos

High resolution background  
bathymetry

(global multi-resolution topography)

High resolution  
ancient charts and  
aerial photographs

Open standards  
and technologies

OpenSearch, OpenLayers, RSS, W3C  
xHTML/JavaScript



The three partners of the A2S project have developed their own databases in relation to their needs and objectives. The A2S Geoportal will connect and synchronise with those databases in order to retrieve a selection of data about the underwater cultural heritage of the 2 Seas. This technical solution will enable the A2S Geoportal to be updated after the end of the A2S project, by synchronising and incorporating new archaeological sites integrated in the partners' databases. Moreover, the open-source architecture enables the A2S Geoportal to be linked to future partners' databases to enhance further the data presented.

Here the partners introduce their databases and demonstrate the full potential of the records that will be contained in the A2S Geoportal. ■

## Flanders Heritage's Maritime Database

Since 2006, Flanders Heritage's database 'Maritime Archaeology' ([www.maritime-archaeology.be](http://www.maritime-archaeology.be)) has provided the public with a window on maritime heritage in Belgian waters in four languages. Next to remains on the seabed, many objects of maritime archaeological value are dispersed across museums and private collections. The aim is to bring together this scattered information into a single, structured dataset.

Following registration, users can add data in four principal categories. The first concerns the *wrecks* of ships and aeroplanes. *Structures* are constructions above or below the water, related to the sea. *Artefacts* are objects recovered from wrecks or structures or as isolated finds. Finally, *events* consist of information that cannot be associated with a known wreck or structure such as documentary data on a shipwreck.

Linking between data in these categories is possible, as is the addition of documents, images, maps and even videos. Special attention is given to information sources such as references to published works as well as to information supplied by the public.

At present, the database stores information on 300 shipwrecks and has over 600 registered users. By linking the database to the A2S Geoportal, this considerable dataset is made even more accessible to maritime researchers and anyone else with an interest in the historical heritage of the North Sea, from anywhere in the world.

## HWTMA's Maritime Archaeological Database

The last 30 years of development of the HWTMA has seen a shift away from paper records, drawings, logs, photographic prints, slides and all other traditional media, taking the plunge with the rest of the world into the Digital Age. This transition comes with its own set of challenges, as well as innovative solutions.

A great part of this involves how we standardize, store and share our data. The A2S Project has demonstrated how partners working to achieve a common goal at the outset has reduced the number of issues arising over the last three years. Data-sharing and databases have been a key element of this and with the inspiration of ADAMAR and the support from GeoData, the HWTMA has begun to centralise and assemble data for a vast number of sites across the UK and internationally. Compatibility has been achieved by following English Heritage's general principles contained in MIDAS Heritage Standards.

The HWTMA uses an open-source database (PostgreSQL) running on a linux server. This provides us with a cost-effective solution and one that has great flexibility and potential. The database is spatially enabled (PostGIS) so that every record can be created, viewed, updated or deleted graphically using open-source GIS software. The database can also be queried to pull out bespoke results depending on the specific needs of the user. The contents are archive-secure in that they can be exported as simple text files in case of proprietary formats becoming obsolete.

The HWTMA database has a new level of accessibility with an online front-end (Vfront - open-source) meaning that records can be created and browsed from anywhere on the internet with a simple login. Regular volunteers with the HWTMA have been instrumental in turning large quantities of paper and indeed digital records into highly structured database entries. Various user privileges mean that the database can be used to create, update and disseminate information more quickly and efficiently than ever before.

The HWTMA database can also be connected using web mapping (e.g. web-GIS to populate sites, images and other documents in a Google Earth style interface). Look out for several examples of this type of work on the HWTMA website ([www.hwtma.org.uk](http://www.hwtma.org.uk)).

# Linking the three partner databases to the Geoportal

[www.a2s-geoportal.eu](http://www.a2s-geoportal.eu)

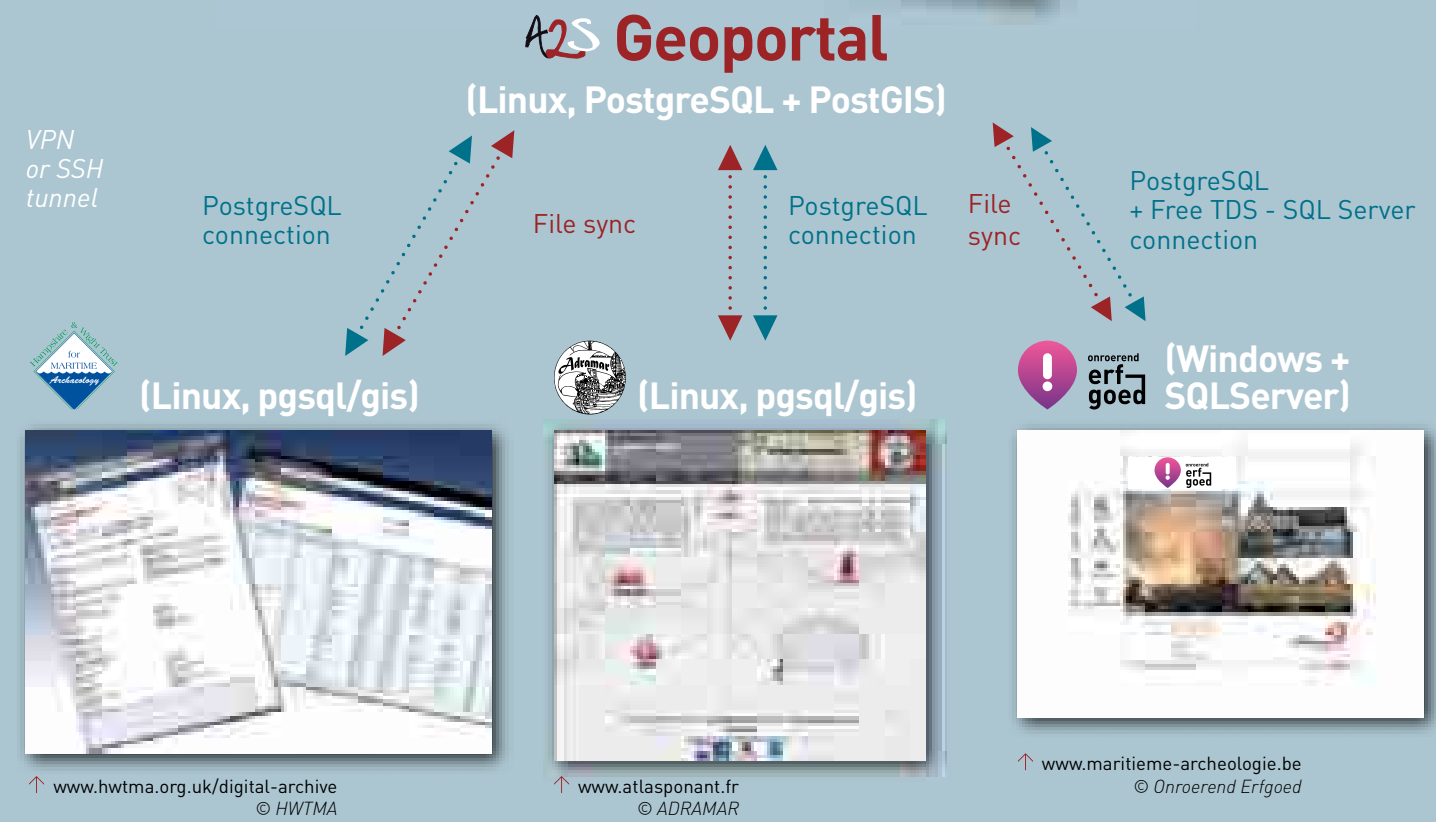



# The French experience

## The Atlas archéologique des biens culturels maritimes de l'Arc atlantique

The French Atlas, which served as a reference for the making of the A2S project, shows the potential and richness of the data contained in the partners' databases which was made available via the A2S Geoportal.

By Django Guyon, Yann Gaonac'h and Charlotte Le Noac'h

### The origine of the French Atlas

With the growing accessibility of scuba diving in the 1950s, and the increasing numbers of divers' associations, among whom were many archaeology and history enthusiasts, the discoveries of underwater remains were on the rise. In the 1980s, Michel L'Hour, Director of DRASSM, initiated a close collaboration with these associations which was the real historical starting point of maritime archaeology on the west coast of France. The French Atlas was a direct development of the exchanges between these spheres of research: maritime activities and diving. Initiated by the ADRAMAR in 2005, it was the result of a long-lasting collaboration between archaeologists, historians, archivists and scuba-diving enthusiasts. It established a systematic inventory of the archaeological heritage of the west coast of France through the study of archaeological collections, as well as text and image resources.

### Documentation

Considering the great quantity of available information, it soon became obvious that it had to be centralised and cross-checked. In order to grant collected scientific data a genuine 'approved' status, the aim of the French Atlas project was to establish its relevance and reliability. Thousands of documents (including archaeological reports, publications, archaeological material, archival documents and underwater photographs) concerning wrecks, submerged terrestrial sites, fish traps and more have been scanned and integrated into a database made available to all kinds of audiences. This include researchers, historians, students, teachers, sailors, enthusiasts and the general public. All information known on the archaeological sites has been classified in five interactive categories (Site, Remains, Images, Archives, Artefacts). The data has been centralised in a Geographic Information System (GIS) and can be accessed through a cartographic interface.

## Deep diving into the French archives

Archival data collection with a view to documenting archaeological sites was a major objective throughout the A2S project. The invaluable documentation produced by the collaborators of the French Atlas was complemented through various specific missions. For example, Jean-Luc Lahitte (COREDO), further examined the archives that Gérard Philoux went through at the French Archives Nationales. This archival find, consisting of 192 accounts of the wrecking of 47 civilian and military ships between the 17<sup>th</sup> and 19<sup>th</sup> centuries, is part of the French Atlas which can be accessed via the A2S Geoportal. A campaign for the digitisation of more than 70 ancient maps was also initiated in order to be able to visualise sites in their historical context. Finally, dozens of documents on wrecked ships in the English Channel and the North Sea were digitised during investigations in the various archive centres (including Archives Départementales, Service Historique de la Défense, Archives Nationales), which complemented the image library of the A2S Geoportal.

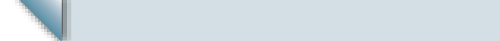

## Enhancement of the marine heritage of the western coast of France

The French Atlas reflects current knowledge regarding the marine archaeological map of the Ponant coast. The numerous and diverse archaeological sites presented allow a better understanding of the marine world, and its human exploration and exploitation. The French Atlas is an essential tool for the protection and enhancement of submerged cultural heritage; it encourages the development of cultural and educational projects through partnerships with heritage and educational organisations. The French Atlas also opens up new perspectives for research by allowing the scientific community to access the archaeological collections of artefacts brought to light during excavations in their own historical context. With the A2S Geoportal, these insights take on a wider significance at a European level, allowing for a more comprehensive understanding of our common maritime heritage. ■



© T. Seguin/ADRAMAR/A2S

The side-scan sonar image of the steamer Fetlar, which was wrecked in 1919 off the coast of Saint-Malo (France), yielded a comprehensive view of the wreck. The exploration of the remains by divers complemented the geophysical data.

### Image data

By definition, submerged marine heritage is not easily accessible. Although the scientific purpose of the inventory of the wrecks of the Ponant coast, conducted as part of the A2S project, was to record the sites, another aim was to share the submerged archaeological heritage with the public.



© MCC/DRASSM

### Remains

By mentioning the type, characteristics and history of these sites, the French Atlas places each in its own context. By constantly exploring a two-way relationship between the archaeological expertise and the historical context, the French Atlas sheds mutual light over both areas, thereby improving our knowledge of maritime heritage.

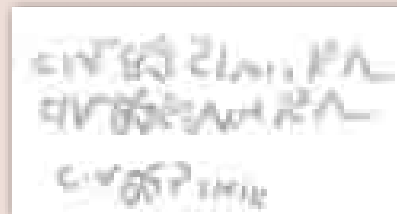

© MCC/DRASSM

The cargo and chronology of the Ploumanac wreck, which was dated to the 4<sup>th</sup> century AD, make it a unique example in northern Europe as well as a remarkable testimony of commercial trade in Antiquity. The study of the inscriptions found on the 271 lead ingots brought to light revealed a connection with two Celtic tribes of Romanized Britain.

© AN/J.L. Lahitte/ADRAMAR



© AD56/T. Seguin/ADRAMAR

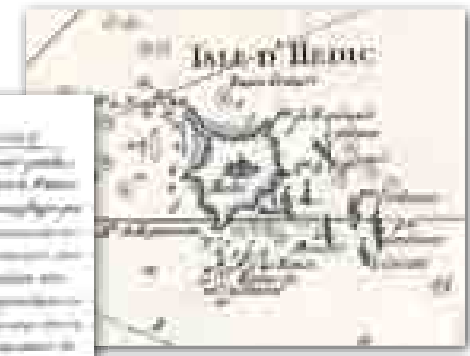

On 26 April, 1676, a letter from the French Ministre de la Marine mentions the loss of the royal flute Le Chariot 'atbwart Hedic'. Less than a century later, in 1764, the rocks upon which the ship was wrecked appeared as Roches du Chariot on a map drawn by Bellin.

## Archives and ancient maps

Archival documents are the tenuous traces of history that can contain valuable information needed to locate and interpret archaeological sites. The data obtained from co-workers and in the various archive centres eventually amounted to substantial documents which can now be made available. These are complemented by an atlas of ancient maps which makes it possible to visualise sites in their historical context and to conduct toponymic studies.

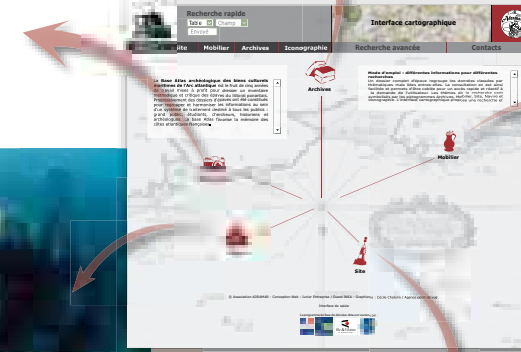

### Site

The wealth of marine archaeological heritage is clearly visible through the topological diversity of the various sites. Ranging from underwater Neolithic habitats to the submerged wrecks of ships and planes and fish traps, the study of underwater sites introduces rich and varied topics. Such diversity was brought to the public through the French Atlas, raising awareness of an often unrecognised heritage and strengthening its protection as a result.

© L. Langouët/AMARAI

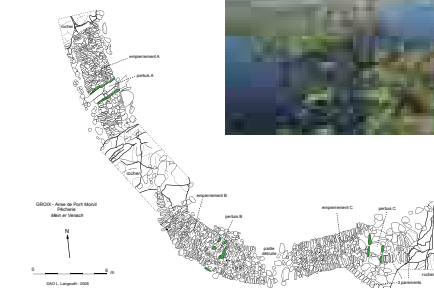
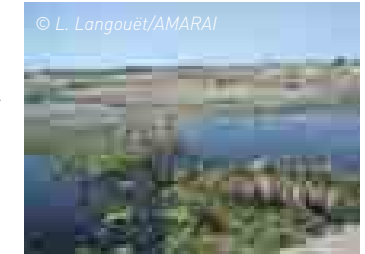

© L. Langouët/AMARAI

The composition of the on-board crockery of the Drummond Castle (1896), the Colombian (1865) and the European (1877), in white faience bearing the inscriptions of the company to which it belonged is an example of how the value of the artefacts presented in the French Atlas may be emphasised. It is possible to define more general study and assessment programmes, in this case in relation to the on-board crockery of the great transcontinental ships, through the analysis of the body of material and the pooling of data.



© T. Seguin/ADRAMAR

## Artefacts

Archaeological collections from underwater excavations are not easily accessible to the public in their entirety. Only the most interesting artefacts, from a museum perspective, are presented to the general public in small sets when they have been restored. The administrative paperwork and the geographic distribution of such artefacts are also obstacles to the researcher. The French Atlas provides a comprehensive view of the collections of materials brought to light on a site, i.e. a real, widely accessible, virtual museum.

An in situ view and archaeological survey of the Porh Morvil (Morbihan) fish trap dated to the 12<sup>th</sup> century AD. Although they are usually barely visible to a layman's eyes, the fish traps found in intertidal zones seem like an inseparable part of the life of coastal communities. They testify both to an original form of exploitation of the coastline environment and to change in sea level. The fishing archaeology study program conducted by the AMARAI association located more than 660 traps dated between 7000 BC and the 18<sup>th</sup> century AD along the coastlines of Brittany.



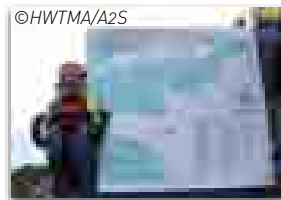

# Education & Outreach

→ Young public watching the live video during the ZI 24 excavation (FR). © ADRAMAR/A2S



The A2S project provided a number of opportunities in each of the partner countries for face-to-face interaction with the public. This included working in formal educational settings as well as public events of a less formal nature.

**T**he A2S visited schools in each of the partner countries through the 3-nation schools programme (see p. 64). Visits by HWTMA's Maritime Bus and educational workshops in France were delivered as part of the *Hermine Itinérante* operation.

Opportunities to engage and inform the general public, beyond the school environment, included the Maritime Bus European Road Trip, the *Hermine Itinérante* operation, the ZI 24 live video, Operation *Meknès*, exhibitions in France and Belgium, fieldwork and conferences. ■

## ZI 24 live video

To engage the public and share our exciting profession, the A2S team invited the public to a live video event on the excavation of the ZI 24 wreck. On board the *Sol Armor* they came alongside *Hermine-Bretagne*. While the team prepared to dive, the public were able to interact with them and enjoy a live presentation of the preparation done on deck before the diving. A cameraman film the divers them working on the site. The camera was linked to the surface enabling the public to watch and hear the archaeologists working under water. At the end of the dive, a diver onboard the *Sol Armor* talked about the work done during the dive and answered questions from the public. More than 140 people come on board over two dives. Response from the public was so positive that we hope to incorporate a similar live video in all future excavations. Such an approach provides a great opportunity to interact directly with the public, showing them their cultural heritage as it is revealed for the first time in centuries.

## Maritime Bus mainland European road trip

European Heritage Days 2011

HWTMA's Maritime Bus enabled underwater video, animation, artefacts, images and information from archaeological sites with relevance to all three partner countries, to tour in an interactive mobile exhibition visiting parts of France and Belgium.

The two-week long Maritime Bus Road Trip was planned to coincide with European Heritage Day events in both countries and the Bus provided a 'shop window' in which to showcase the A2S project. Public events included Heritage Days in Ostend, Belgium (10 and 11 September 2011) and in the Château du Guildo, Côtes-d'Armor, France (17 and 18 September 2011). In addition, the touring exhibition was taken to the schools in France and Belgium that would be involved in the 3-nation schools programme. During the two-week long trip, the Maritime Bus covered nearly 3,000 km and more than 1,000 people came on board to learn about the A2S project and the shared maritime heritage of the partner countries.



↓ The Maritime Bus European Road Trip was filmed by the A2S team and put on YouTube. © A2S



← Maritime Bus european road trip in Raversijde (BE). © HWTMA/A2S



← Hands-on learning: young people try out archaeological techniques at Guissény College (FR). © ADRAMAR/A2S



↓ Maritime Bus at the Archaeological Museum Walraversijde (Provincial Domain Raversijde) during Open Monuments Day 2011 (BE). © Onroerend Erfgoed / A2S



An archaeologist explaining the work on the ZI 24 wreck site after the dive (FR). © ADRAMAR/A2S

## Hermine Itinérante operation

Promoting the discovery of the archaeological heritage through the *Hermine Itinérante* project on board ADRAMAR's ship *Hermine-Bretagne*

In May and June, 2011, ADRAMAR set-up an event called *Hermine Itinérante: à la découverte de l'archéologie sous-marine* as part of its cultural outreach programme.

This event which was intended for the general public and schools, presented the diversity of the underwater archaeological heritage, the activities of the association and the A2S project. Four Breton ports were selected to welcome ADRAMAR's research ship *Hermine-Bretagne*. Several educational workshops (a visit of the research ship, excavation grid and inventory tent, and an experimental archaeology rope-making workshop using ancient techniques), gave visitors a chance to figure out what the work of marine archaeologists is all about. A series of conferences in all visited ports offered a double approach with a general presentation of underwater archaeology and more specific insights into local heritage. After a one month journey and events covering 14 days, the *Hermine Itinérante* reached almost 2,000 visitors, and more than 440 pupils from twelve schools – from nursery school to secondary school – attended the educational workshops.

→ School visit during the *Hermine Itinérante* operation in Concarneau (FR).  
© ADRAMAR/A2S

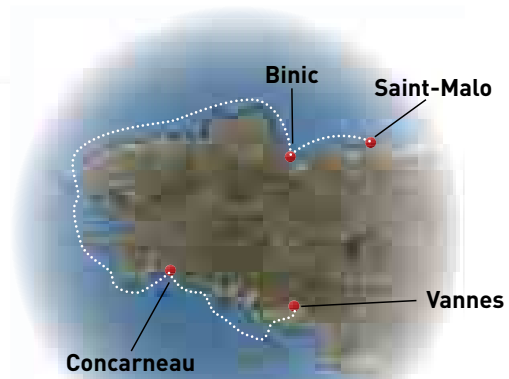

→ School visit during the *Hermine Itinérante* operation in Concarneau (FR).  
© ADRAMAR/A2S



## Involving volunteers

Enthusiastic volunteers helping the HWTMA as part of the A2S project during the diving fieldwork were a welcome and very useful resource. A total of 83 volunteers from the A2S partner countries took part during the 2010 and 2011 diving season; this consisted of suitably qualified divers, boat skippers and support workers for activities such as, cylinder filling, sample processing and catering. The diving took place over 62 days in total in and around the Solent, and up to 12 miles south of the Isle of Wight.

Five dive boats with excellent dive-boat skippers helped to carry the vast amount of kit needed for diving operations and to safely deploy and retrieve the divers. An added advantage was that volunteers had the chance to train and learn new skills 'on the job' during the fieldwork. The hectic nature of week-long fieldwork exercises required that accommodation was sought on a total of seven occasions which ranged from camping sites and scout huts to villas in areas in the vicinity of the diving operation. The benefit of having accommodation near to site allowed volunteers from further afield to participate for longer than just one day, bringing an all-important feeling of team spirit and camaraderie to the project.

↑ Volunteer David Johnstone takes the plunge (UK). © HWTMA/A2S

## Operation Meknès

commemorating the 70<sup>th</sup> anniversary of the liner's sinking

During the confused period which took place in the early days of WWII, on 24 July 1940, French liner *Meknès* was torpedoed by a German motor torpedo boat patrolling the waters of the English Channel, even though the Armistice between Germany and France have been signed on 22 June 1940. Of the 1279 sailors on board 429 died in the attack.

In 2010, ADRAMAR and HWTMA, in collaboration with associations *Saint-Malo Plongée Emeraude* and *Aquateck Vision* and with the UK Ministry of Defence, took part in archival research, aimed at finding any documents that would shed light on the sinking, and underwater survey of the wreck which today lies 60m below the sea.

Following the operation, the association '*Les Oubliés du Meknès*' (forgotten victims of the sinking of the *Meknès*) organised a ceremony on 24 July 2010, i.e. the 70<sup>th</sup> anniversary of the shipwreck, attended by the families of the victims. On the shore in Dieppe where most bodies were recovered and buried, a commemorative stone in memory of the fallen sailors was unveiled and at the same time a commemorative plaque was laid on the wreck, illustrating the historical and memory dimension of the archaeological study of contemporary vessels.

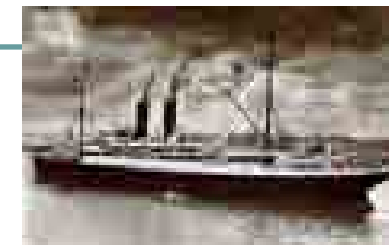

↑ SS Meknès. © All rights reserved

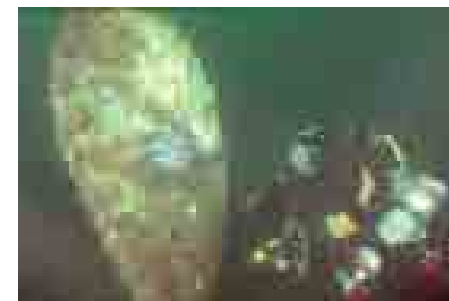

↑ Memorial plaque on the propeller of the SS Meknès (UK).  
© Saint-Malo Plongée Emeraude

## Exhibition

### 'The archaeological Atlas of the 2 Seas'

During the summer and fall of 2012, the Provincial museum at Raversijde (Oostende, BE) will host an exhibition dedicated to the research results of the A2S project. The exhibition will shed a light on recent research on different archaeological sites. With photographs, film and a select number of distinctive objects, the public gains an insight into the diversity of the maritime heritage and of its research methods. Not only the wreck sites of the Second World War HMS *Wakeful* and the 18<sup>th</sup>-century '*Vliegende Hart*' but also the late medieval fishing village of Raversijde-beach and the Mesolithic site of Bouldnor Cliff are presented.

Based on these intriguing examples the different aspects of this maritime archaeological project are explained: archival studies and fieldwork using the most recent scientific methods. And last but not least, the education aspect within the A2S project is not forgotten.

→ Practical:

- exhibition from 5 July to 11 November 2012 at Archaeological Museum Walraversijde  
Nieuwpoortsesteenweg 636  
8400 Ostend, Belgium

The Departmental Archives of Ille-et-Vilaine are hosting the exhibition *À l'abordage ! Les Corsaires entre mythe et réalité*. Around the drawing of Patrice Pellerin (*L'Épervier*), the artefacts of the Natière shipwrecks and the archives, the exhibition is showing the similarities between the work of the cartoonist and the archaeologist. Through the pictures taken during the A2S project and the sites surveyed, the public will discover the archaeological scientific approach while immersing itself in the realm of the French corsair.

→ Practical:

- exhibition from 4 June to 31 August 2012  
Departmental Archives of Ille-et-Vilaine  
1, rue Jacques Léonard  
35000 Rennes, France

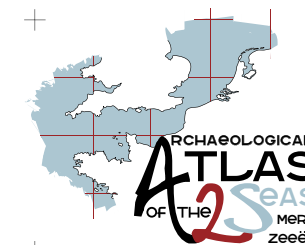



→ Particulars of attacks on merchantvessels by enemy submarines, a document completed by the highest ranking survivor of merchant ships sunk during the First World War.  
© The National Archives (UK), ADM 137/1476.

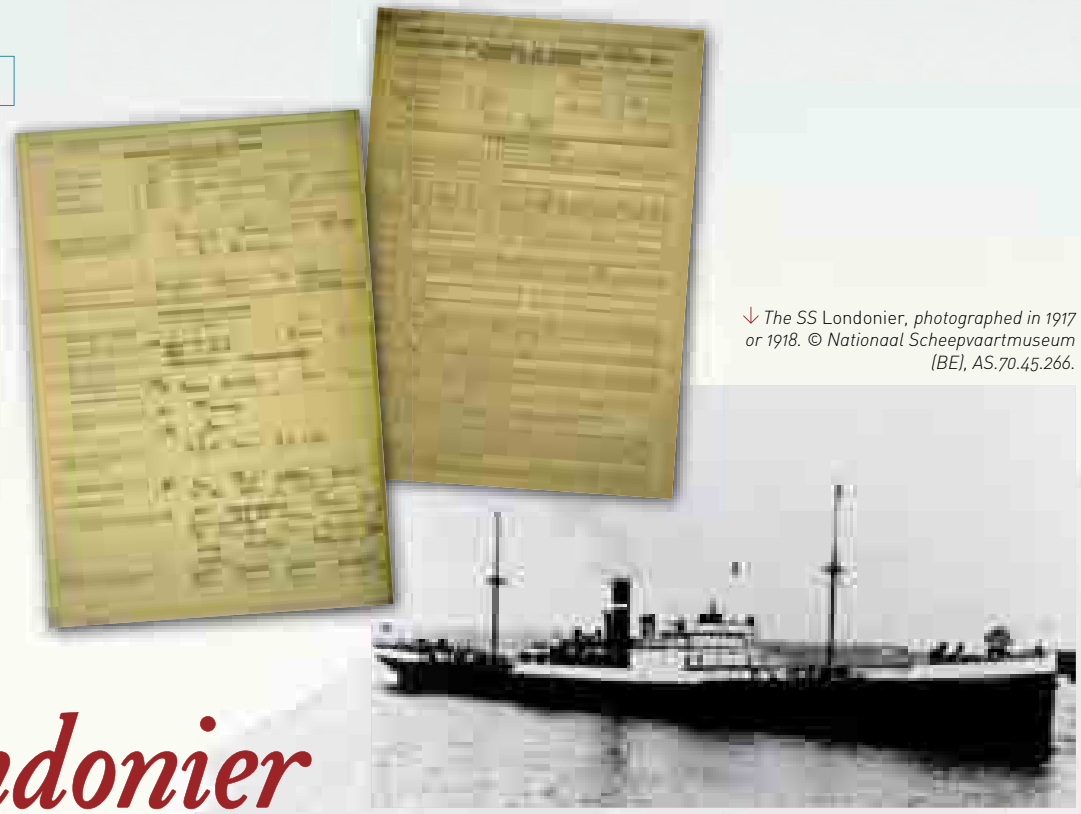

↓ The SS Londonier, photographed in 1917 or 1918. © Nationaal Scheepvaartmuseum (BE), AS.70.45.266.

# SS Londonier

The *Londonier* constitutes an excellent case study from the A2S project, clearly demonstrating the common heritage that results from the shared maritime history of the three coastal state partners and how the various activities of the A2S project are applied in relation to a single site.

By Amanda Bowens and Stephen Fisher

The wreck of the *SS Londonier* lies in the English Channel. The ship had been located, researched and identified prior to the A2S project by Mr David Wendes (Wendes, D. 2006). However the A2S project facilitated further historical and archaeological research by project partners' staff and volunteers.

## SS Londonier - an international story

*SS Londonier* was a Belgian-owned steamship, built and launched in England in 1911. It was originally named *SS Vrijhandel*, but was renamed *SS Londonier* in 1917 when its owners changed. On 12 March 1918 *SS Londonier* was on charter to the French Government when it left Calais bound for the UK Bristol Channel. The vessel was armed with a single QF 12-pounder 12 cwt naval gun and there were 25 people on board comprising at least 12 Belgians, three Russians, two Dutch, two British, one Swede and one Norwegian. At approximately 2am on 13 March 1918 *SS Londonier* was torpedoed by *UC-71* and the crew abandoned ship. Only 13 men survived; 11 men died in the explosion or drowned, and a further one died of exposure. The submarine was glimpsed momentarily by the ship's crew as they gathered in the lifeboats and at around 2:30a.m. it was seen to dive.

## Cross-border desk-based research

A visit to the UK National Archives provided new information about the nature of *SS Londonier's* final voyage. It revealed a number of interesting facts including: that the name of the master had been mistyped in an Admiralty document; that the ship had been alone and not in convoy as had previously been thought; that one of the crew members died of hypothermia in a lifeboat; and that the name of the ship's owners was out-of-date in the Admiralty report.

This information enabled further internet research which revealed information about the shipyard in which *SS Vrijhandel/SS Londonier* had been built, and its crew manifest at the time of its arrival in New York in early 1918.

Meanwhile, exploration of Belgian historic sources revealed the names of Belgian crew members who had been killed in the sinking which, when combined with the Admiralty survivors list from the UK, enabled the compilation of a near complete crew list of the 25 individuals on board the ship when it sank.

With the ship's name and ownership thoroughly established, it was possible for Belgian researchers to conduct more detailed research into the archives of *Compagnie Maritime Belge* (CMB). This uncovered an article on the *SS Londonier*, written in 1936, that described

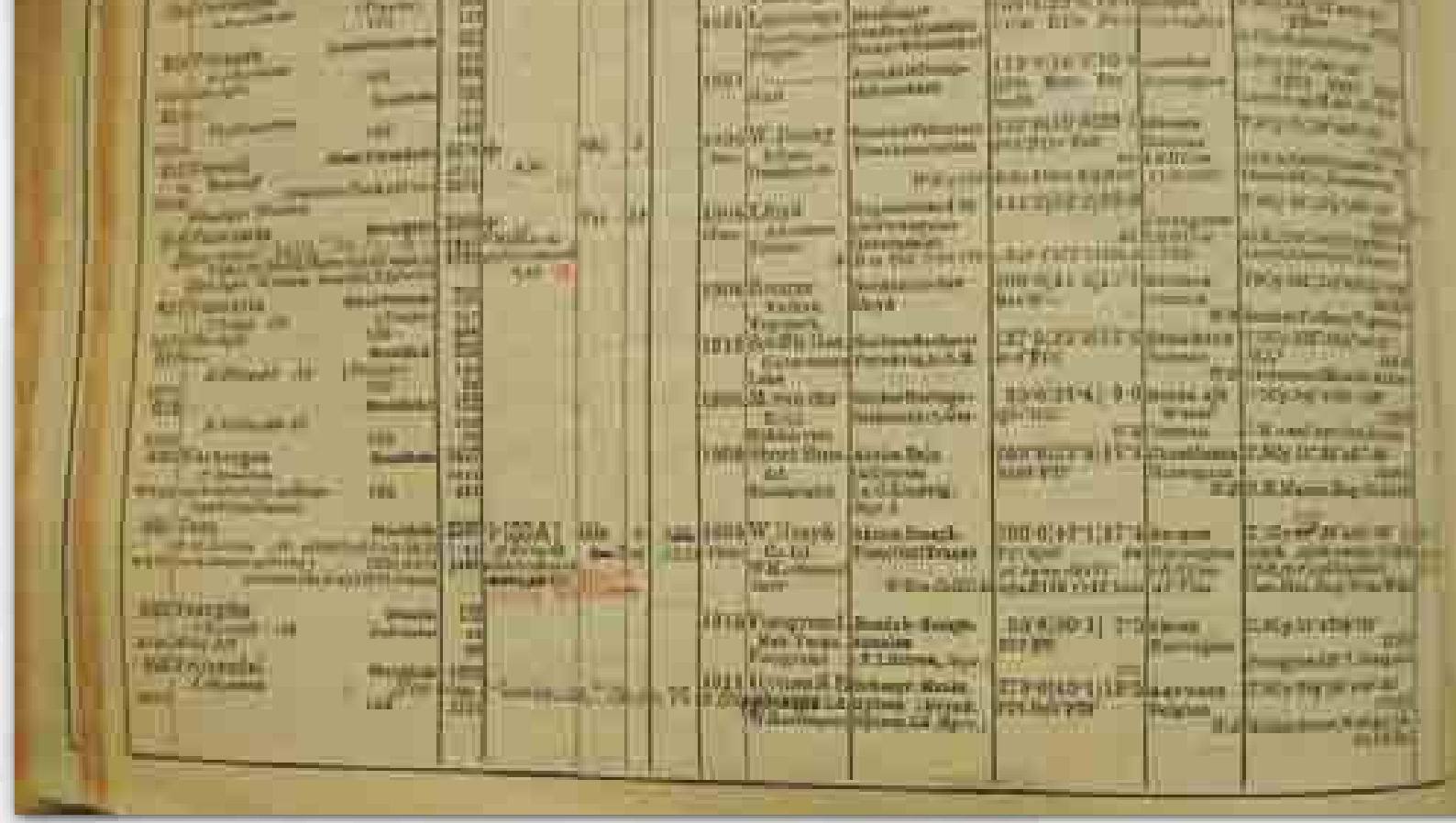

↑ The Lloyds Register for 1916/1917, indicating the change of name from *Vrijhandel* to *Londonier*.  
© The Lloyds Register of ships, 1916-1917. Volume II: Steamers, p. 274.

→ Certificate of Tonnage of the steamship named *Vrijhandel*.  
© The Belgian Ship Mortgage Registry, Antwerp, Article 1067.

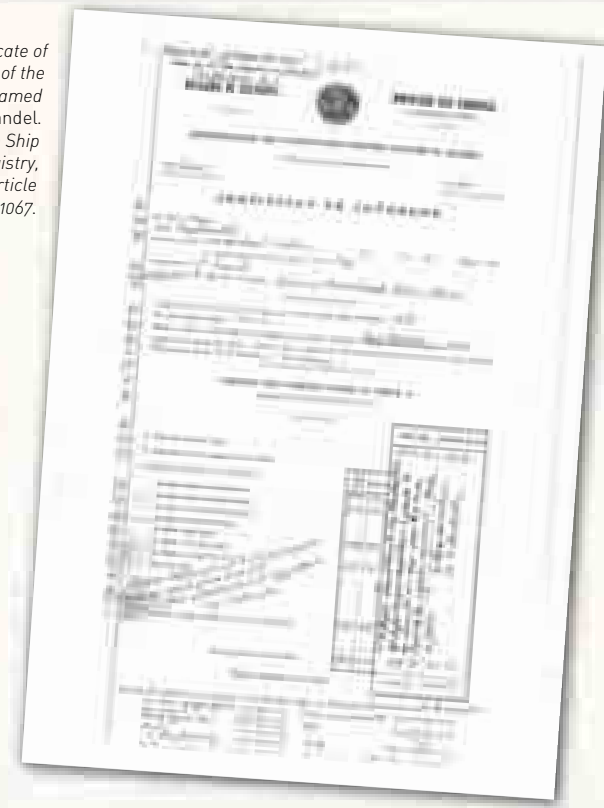

its career and loss in 1918, using sources lodged with the shipping company. These not only made use of their own paperwork, but also survivor statements containing more detail than the Admiralty reports. The article contained a great deal of information about the ship pre-1918 that was not in the Admiralty reports and conversely the Admiralty reports contained lots of information about the sinking and survivors that was not in the Belgian article. The Belgian historic archives also revealed French documentation in the form of a certificate of tonnage for *SS Vrijhandel* from 1911.

The desk-based research also highlighted the fact that there was a second *SS Londonier* launched in 1919. This ship was very similar in size and appearance to the 1911 *SS Londonier* and it was discovered that photographs of the newer vessel had, in the past, been confused with the ship launched in 1911.

The desk-based research into *SS Londonier*, involving the sharing of methodologies, sources and information across borders and between countries, has resulted in a more complete picture of the story behind *SS Londonier* (1911) and its sinking than would otherwise have been possible. As such the ship provides an exemplary case study of what has been achieved through the A2S. ● ● ●

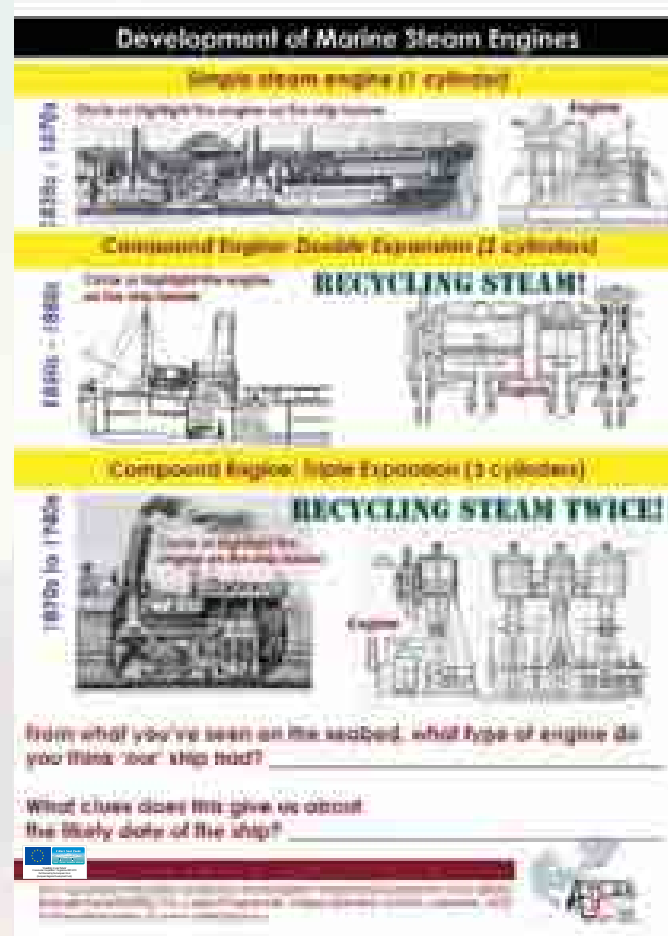

← The 12-pounder gun mounted on the stern of the SS Londonier (UK). © H. Morrison

## Fieldwork

Fieldwork on the SS *Londonier* site included diver survey, using measuring tapes, video and geophysics in the form of a side scan sonar survey. The overall objective was to establish an accurate record of visible archaeological material, while confirming the current position, extent, stability and character of the site.

Diving on the site was carried out by a multi-national mixed team of professional and volunteer divers. While all three partner organisations have worked closely and dived together on a range of A2S sites, the SS *Londonier* fieldwork was carried out by a team of divers from the UK and France, with the results being used by all three partner countries (see page 18-19).

Side-scan sonar data was collected from the SS *Londonier* site using a system and staff-time donated by Kongsberg GeoAcoustics and an acquisition system supplied by CodaOctopus. Work was conducted from *Wight Spirit*, the standard work vessel employed by the HWTMA during fieldwork diving projects.

While both the diving and geophysics work on the SS *Londonier* site was limited by adverse weather conditions, it was possible to achieve the main fieldwork objectives.



A propeller blade and section of the rudder of the SS Londonier (UK). © H. Morrison

## The shipwreck

The remains of SS *Londonier* lie scattered around a flat seabed comprising sand and gravel. Most of the wreck lies close to the seabed, the exceptions being the engines, boilers, donkey boiler and rudder which stand proud. The engines are the highest part of the wreck, approximately 4-5m above the sea floor. The stern face of the starboard boiler is missing, revealing the water

pipes inside. Aft of the engine it is possible to follow the propeller shaft to the stern of the wreck where the gun is visible. Life-jackets can be seen pinned under frames adjacent to the port side of the propeller shaft. Forward of the boilers the wreckage is more disparate with plates lying flush with the seabed. Two anchors are visible at the bow, still in the hawse pipes.

← One of the worksheets created for the 3-nation schools programme (English version). © A2S

↓ Pupils learning about maths, history and technology by applying archaeological techniques during the 3-nation schools programme (BE). © Sint-Bernarduscollege, Nieuwpoort/A2S



↑ Information about the SS Londonier can be found on the A2S Geoportal. © A2S

## Geoportal

Information gathered through desk-based research and archaeological survey during the A2S project has been entered into the database that sits behind the geoportal so it can be accessed by the general public. Users can search for the ship by name, or click on a geographical area for further information.

## Dissemination and communication

Dissemination and communication to all audiences has been central throughout the A2S project. All information gained through cross-border collaborative work under desk-based research and fieldwork has been disseminated and communicated using a range of venues and approaches in each of the partner countries, during the HWTMA Maritime Bus mainland European road trip. Of course, information continues to be disseminated via the A2S Geoportal. The SS *Londonier* has received additional coverage as the focus of the A2S 3-nation Schools Programme.



Pupils and teachers involved with the programme showed great enthusiasm as can be seen from their feedback:

“The project demonstrated the interconnected histories of England, France and Belgium; studies which they wish to develop in this school.”

French teacher

“Very nice to be able to offer a quality extra curricular activity – something really different?”

English teacher

“Made me interested in something I had not known anything about before.”

English pupil

“Very positive experience and definitely worth participating in.”

Belgian teacher

“I thought every bit of the project was super. It was a nice experience for everyone. The film we made for the exhibition was super fun.”

Belgian pupil

“On to the next project of shipwreck history.”

French pupil

## A2S 3-nation Schools Programme

This innovative programme saw organisations and schools in the three partner countries working collaboratively using information and data collected through the desk-based research and fieldwork elements of the A2S project.

Each partner organisation recruited a school in their country to work with. These schools were:

- England: Toynbee School Hampshire, England
- France: Collège Diwan Guissény, France
- Belgium: Sint-Bernarduscollege Nieuwpoort, Belgium

The project was based on the scenario that a seabed anomaly had been found during a marine geophysics survey. Divers were called in to investigate the anomaly and from this point, the pupils took on the role of the maritime archaeologist, beginning with a tri-lingual ‘virtual dive’. Each week, guided sessions and bespoke materials took pupils through a realistic process of archaeological and historical investigation.

The in-school delivery aspect of the project was approached slightly differently in each of the partner countries. In the UK and Belgium the project sessions took place in a weekly after-school or lunch club, while in France the sessions ran during the school day as part of their Breton language classes.

A suite of educational resources was created in four languages (English, Dutch, French and Breton) and with the support of maritime archaeologists from A2S partner organisations, pupils used the same materials in all three schools during a unique seven-week programme.

## Results

The A2S 3-nation Schools Programme has enabled the Belgian partners to develop a new relationship with teachers and pupils of a local school. French and English partners have been able to develop existing school partnerships by offering a programme of activity and resources that did not previously exist.

Sixty-two pupils and nine teachers in three countries have been introduced to maritime archaeology and have an understanding of how it relates to traditional school subjects and their national curricula.

All three schools are interested in running similar programmes in the future and the on-line, paper and practical resources developed for the programme constitute part of the project’s legacy and have already been used in other schools. ■

## References

- Board of Admiralty, English Channel: German Submarines, 1-15 March 1918. National Archives ADM 137/1476.
- Scarcériaux, P. (1936). Histoire Londonier. *Wandelaer et sur l'eau*, August, n° 164, pp. 378-381.
- Wendes, D. (2006). *South Coast Shipwrecks*. Wight Spirit Charters, pp. 174-175.



← ↑ Pupils using the A2S resources during the A2S 3-nation Schools Programme (UK). © HWTMA



↑ The video produced by pupils at Toynbee School, telling the story of the research of SS Londonier (UK).



↓ → Newspaper front pages of the SS Londonier sinking made by the pupils of Diwan College Guissény (FR). © Collège Diwan Guissény/A2S

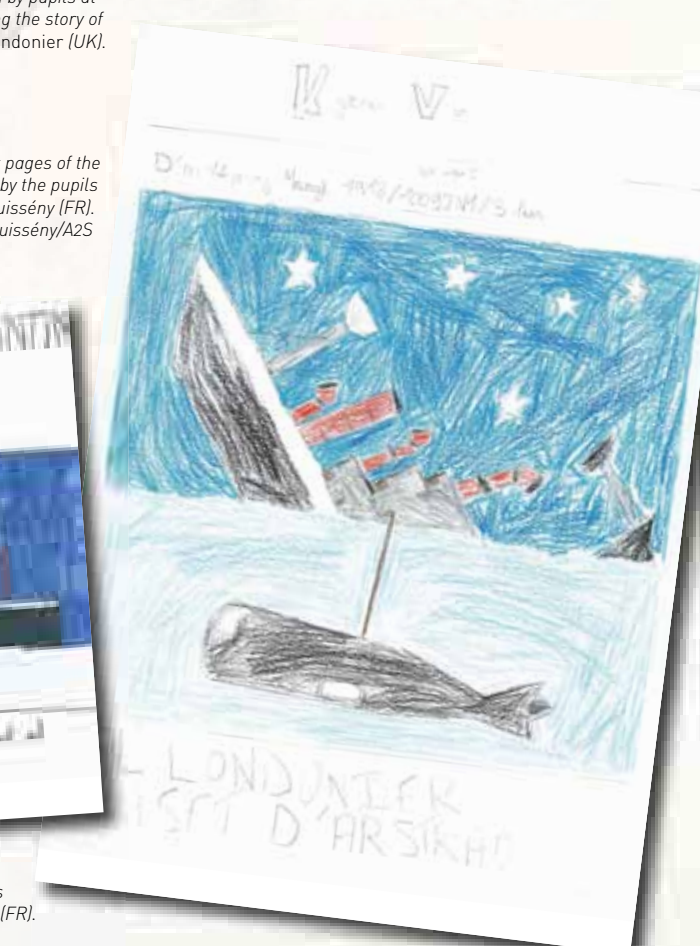

← A2S 3-Nation Schools Programme in Guissény (FR). © ADRAMAR/A2S



→ UNESCO Conference, 13 and 14 December 2011, Brussels (BE). © A2S

# Communication

## informing diverse audiences

The specific challenges and opportunities presented by the A2S project meant that communication with the various stakeholders and partners was vital from the very beginning of this European project.

To this end we set up a programme of activity and range of communication tools to share information with broad and diverse audiences during the whole life-cycle of the project. This was set out in the project's Communication Strategy which was constantly reviewed and amended during the course of the project.

Project communications in the three participating countries were harmonised and given a consistent identity through the creation of a 'graphic identity' for the project, comprising standardised Powerpoint templates, poster, brochure, leaflet and banner designs. A communication brochure introduced the A2S project, detailing the contributions of the various partners (funders, scientists and volunteer workers) and a flagship website was established at [www.atlas2seas.eu](http://www.atlas2seas.eu) [www.atlas2mers.eu](http://www.atlas2mers.eu) [www.atlas2zeen.eu](http://www.atlas2zeen.eu).

The following principles underpin the A2S Communication Strategy:

- Stage 1:** data collection, joint field operations.
- Stage 2:** data checking, approval by the scientific partners at national and European level.

**Stage 3:** Delivering information to the public through promotional policies targeting various audiences (scientists, archaeology enthusiasts, the general public, schools, funders).

We developed several forms of communication intended for very diversified target audiences, these included:

- Media events aimed at funders, such as the ZI 24 dive covered via a duplex broadcast incorporating a selection of special guests.
- For scientists, we organized conferences and working groups with scientific reports such as our scientific committee which meets on a yearly basis.
- For the general public, special events such as the *Hermine Itinérante* project in France or the HWTMA-sponsored Maritime Bus trip organised to coincide with European Heritage Days in France and Belgium.
- For schools, an interactive project named 'Mystery shipwreck' involving three schools (one in each participating country) working collaboratively to research a single wreck with links to each country.

A documentary film was also made to

promote the project more widely beyond its funding circles.

A few promotional activities were recorded, filmed and made available online the project's website and on youtube.

All actions were recorded photographically and archived.

This common experience has been also an opportunity for us to create excellent communication tools such as didactic tarpaulins on the project and the career of submarine archaeologists, and also special educational tools intended for school pupils.

An end-of-project publication was produced to present the common work, activities and outcomes of the partner organisations, this is complemented by an mobile exhibition which will form part of the project's legacy. All activities and tools were designed collaboratively, resulting in a consistent set of documents whose relevance will reach well beyond the funded life-cycle of the project. These can be downloaded via the project website and on the partners' websites. ■

More than **30** conferences/lectures given during the A2S project

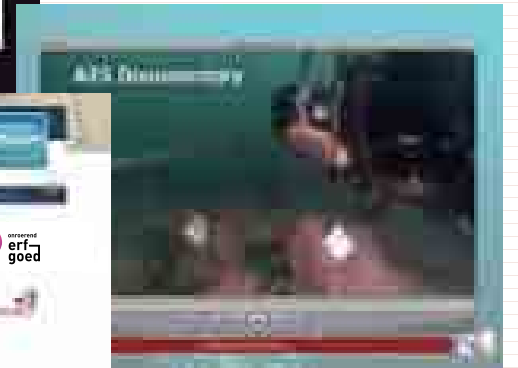
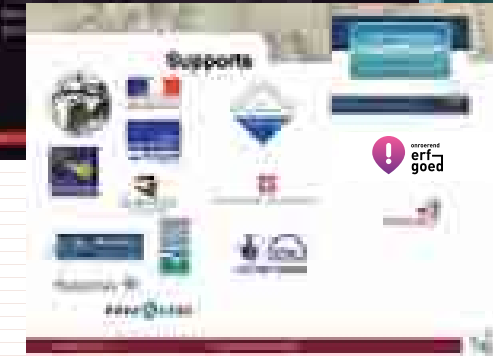
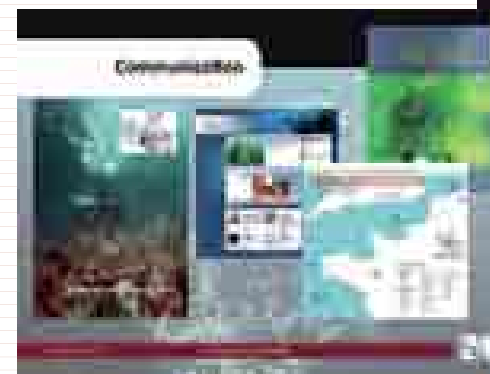

← Template for conferences presentation. © A2S

**35** minutes documentary produced during the A2S project



→ Panels presenting the A2S project, realized for European Heritage Days 2010 (Trilingual version). © A2S



↑ → Panels presenting the education part of the A2S project, realized for European Heritage Days 2011 within the framework of the Maritime Bus european road trip (Flemish and French version). © A2S





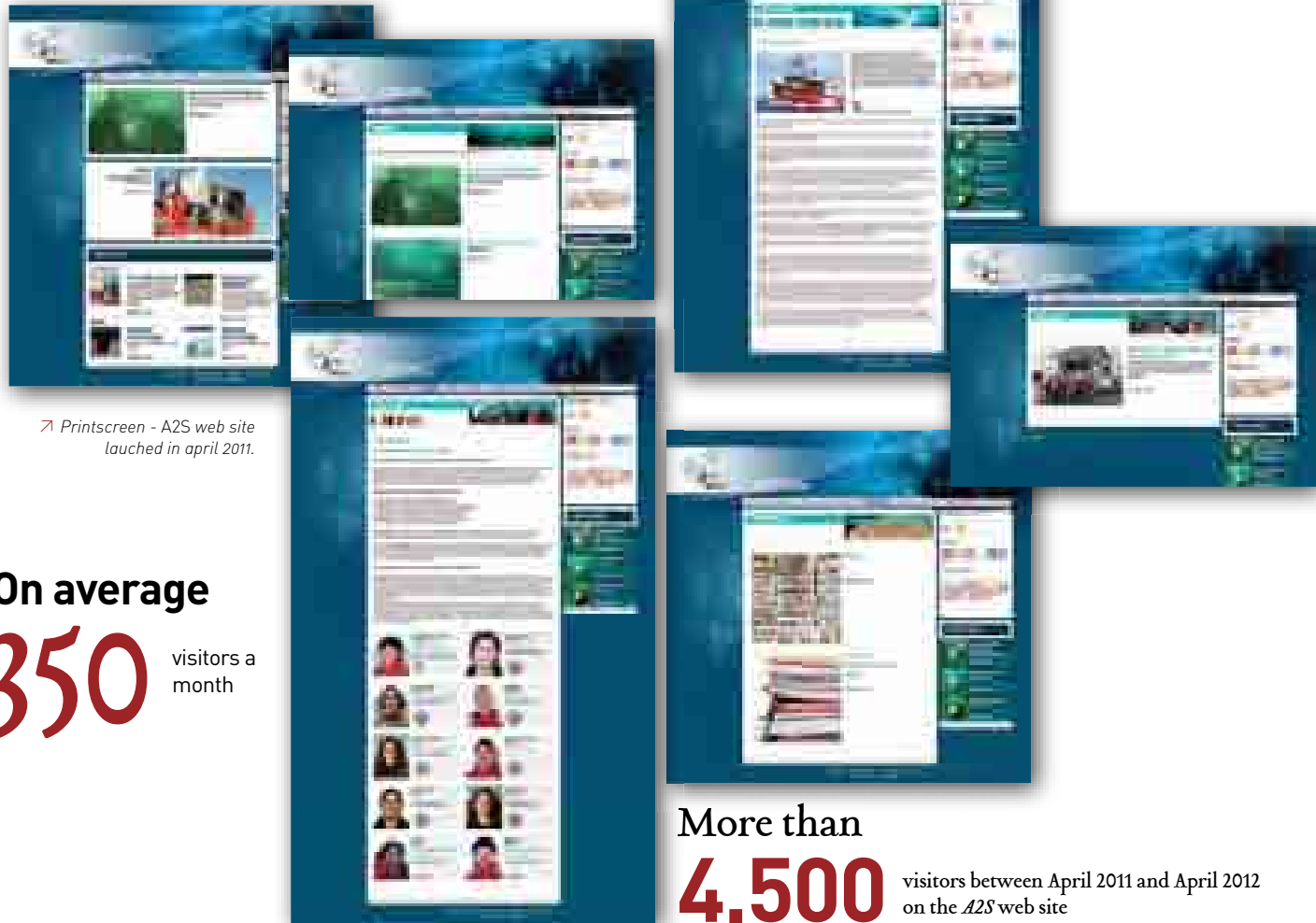

➤ Printscreen - A2S web site lauched in april 2011.

On average  
**350** visitors a month

More than  
**4,500** visitors between April 2011 and April 2012 on the A2S web site

[www.atlas2mers.eu](http://www.atlas2mers.eu) [www.atlas2seas.eu](http://www.atlas2seas.eu) [www.atlas2zeen.eu](http://www.atlas2zeen.eu)



➤ December 2011 - A2S web site PDF to download Fieldwork.



➤ December 2011 A2S web site PDF to download Outreach.

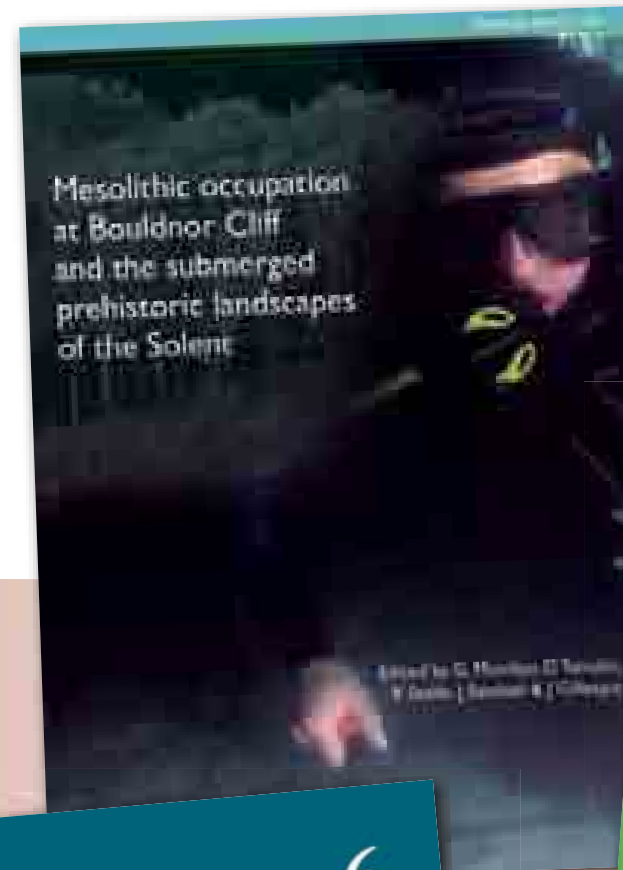

**17**

scientific publications during the 4 years of the A2S project

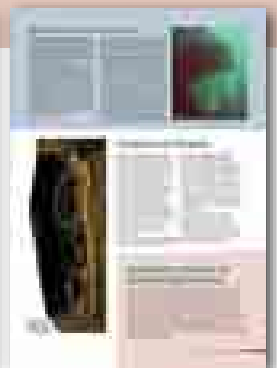
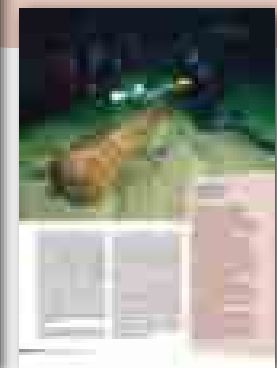
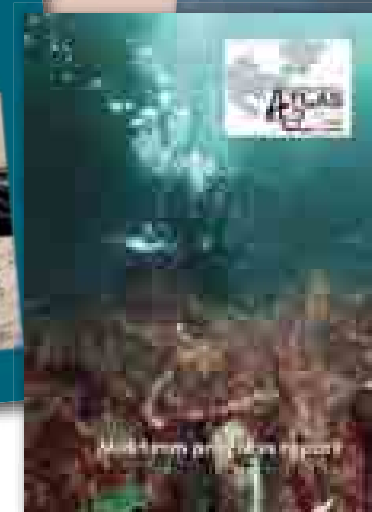

↗ Printscreen - Meridian TV, november 4<sup>th</sup> 2011.



**6** television programmes  
**9** radio programmes

↘ Interview for West Flemish television (Focus), August 2009, about Maritime heritage research in Belgium. © Onroerend Erfgoed



↑ Press article on the Meknès operation appeared in the Octopus magazine in October 2011.

↓ Leaflet realized for Hermine Itinérante operation in May 2011.



↑ Press release realized to announce the Meknès operation in September, 2011.

## In figures

In the frame of A2S 3-nation Schools Programme

More than  
**20**  
 press articles

**3** schools

**62** children

**9** teachers

**7** weeks programme

**4** common outreach projects

More than  
**3,500**

visitors welcomed within the framework of the various events organized around the A2S project

↑ Nautical Archaeology Society newsletter appeared in Spring 2011.

**16**  
 newsletter articles

More than  
**2,000**  
 photographs taken



# Project experience...



Hull of the shipwreck Fetlar (FR).  
© T.Seguin/ADRAMAR/A2S

The history of Europe is a tempestuous one. It has been born of invasions, conflicts and political intrigues. These events have divided nations in years gone by. Now, through the A2S project, people from different nations have been linked around a common history, bridging cultural barriers and strengthening relations. The project has shown the value of heritage as a tool to unify and it has demonstrated the rewards that can be gained when nations collaborate.

**By Garry Momber, Alexandre Poudret-Barré,  
Ine Demerre and Inge Zeebroek**



Launch of a side scan sonar and a magnetometer from the research vessel Hermine-Bretagne (FR). © T.Seguin/ADRAMAR/A2S

**T**he data gathering and research undertaken throughout the A2S project has highlighted the richness and magnitude of the submerged cultural heritage in our common seas. Over 1,500 archaeological sites have been identified and listed in the region while over 3,000 underwater artefacts and historical photographs have been catalogued. During fieldwork, 100 archaeological sites were investigated by maritime archaeologists, among these 36 geophysical anomalies were dived and inspected. All the results have been collated and stored on databases which are now accessible through the A2S online Geoportal that can be accessed by curious members of the public, students, academics, coastal manager or policy makers. The case studies presented in this report demonstrate the diverse range of research, survey and excavation methods used by the partners. The variety is important as it facilitates the provision of training and the building of expertise. The individual studies have been delivered by team members from all three nations working closely together to share methodologies, skills and experience. As a result of the collaboration, larger undertakings were attained and all partners have emerged stronger; being more able to deal with a broader cross section of maritime archaeological challenges.

The outreach and education components have been particularly strong with over 600 people being directly involved while many thousands more have participated in A2S activities. Events have included public lectures, seminars, open days and tours in each of the partner countries. A single cruise around the coastline by *Hermine Bretagne* received over 2,000 visitors while the Maritime Bus reached out to 1,000s of people on a trip from England to France, Flanders and the Netherlands. Each expedition included close associations with schools, three of which were involved in a venture to identify a 'Mystery Wreck'. These were Collège Diwan of Guissény, Brittany, France, Sint Bernarduscollege Nieuwpoort, Flanders, Belgium and Toynbee School, Hampshire, UK. They worked together by sharing information to investigate and identify the SS *Londonier* which is a wreck with associations common to all three nations. The results were disseminated on the A2S website ([www.atlas2seas.eu](http://www.atlas2seas.eu)), but more significantly by the children themselves who produced their own outreach tools including in-house newspapers, films and animations. Educational resources were created in English, French, Dutch and Breton.

In addition to the large number of direct project participants a comprehensive communication strategy has taken the archaeological

“ *The A2S project has unified international teams of archaeologists, volunteers and school children ranging in age from 8 to 88.* ”

results to a much broader spectrum of society. There have been more than 20 articles in the local and national press, plus 16 newsletter articles while the website received over 4500 hits in its first year. The work has been reported in 17 academic publications, it has been the subject of 15 televised and radio news reports, and featured in a documentary. The communication has proved essential to inform the wider public and ensure that awareness of the project does not diminish. The published works along with the production of a 35 minute broadcast quality film will create a legacy that ensures the successes are not forgotten and overlooked. Indeed, the sharing of experiences between the partners has created a fertile environment and a cohesive team primed to push forward new cultural enterprises.

## A Way Forward

The A2S project should be seen as a pilot that has pioneered a range of successful initiatives. It has unified international teams of archaeologists, volunteers and school children ranging in age from 8 to 88. It has provided a platform for cross-border collaboration in a way that is seldom witnessed. This is something worth maintaining as foundations have been laid that can enable key elements of the A2S project to be rolled out to a wider audience. First, the Geoportal provides a vehicle for a wide section of the diving and non-diving community to contribute, whereby increasing the number of submerged heritage sites. Secondly, the international team of maritime archaeologists now have the skills and capacity to deliver projects on a supra-national scale. Thirdly, research between nations by avocational volunteers has built bridges and shown how it can link cultures. Finally, the submerged cultural heritage has proven to be a very powerful educational tool with great teaching benefits. More sites should now be integrated into educational resources that can enthuse school children to engage with their national curriculum in a fun and proactive manner. ■

# Acknowledgements

## *A2S* Steering Committee Members

Geoff Bailey  
Marc De Bie  
Jerzy Gawronsky  
Michel L'Hour  
Tine Missiaen  
Adrian Olivier  
Marnix Pieters  
Eric Rieth

Charlotte Georgeault  
Alexandra Grille  
Django Guyon  
Anne Hoyau-Berry  
Franck Jouet  
Victor Laforêt  
Jean-Luc Lahitte  
Charlotte Le Noac'h  
Georges Le Pelletier  
Jean-Paul Le Raer  
Paul Marec  
Frédéric Osada  
Alexandre Poudret-Barré  
Marine Sadania  
Damien Sanders  
Teddy Seguin  
Elisabeth Veyrat  
Magali Veyrat  
Catherine Volant

### DRASSM Staff

Denis Dégez  
Olivia Hulot  
Michel L'Hour  
Christine Lima  
Denis Metzger  
Christian Péron

## Match funding support

DRASSM, Ministry of Culture and Communication  
Region of Brittany  
Department of Ille-et-Vilaine  
Department of Morbihan  
Department of Côtes-d'Armor

## Technical support

Armor Lux  
Aqualung

## *A2S* French team

### ADRAMAR Board Members

Eric Mancey, President  
Marie-Pierre Brin, Treasurer  
Erwan Marion, Secretary

### ADRAMAR Staff

Henri Bernard-Maugiron  
Emmanuel Berry  
Jessica Berry  
Cécile Chatelin  
Rémy Chirié  
Francis Crespin  
Charles Dagneau  
Yann Gaonac'h

## Volunteers

Jean-Maurice Authié  
Tony Babarit  
Gérard Bousquet  
Patrice Cahagne (†)  
Yvon Chartier  
Michel Cloâtre  
Elie Coantic  
Fabrice Courault  
Daniel David  
Alexis Deniau  
Jean-René Donguy  
Denis Douillez  
Gilles Drogue  
Mathias Dufour  
Patrice Enault  
Jean-Michel Eriau  
Emmanuel Feige  
François Floc'h  
Alain Foulonneau  
Maurice Grenon  
Joë Guesnon  
Michel Huet  
Bernard Jacq  
Jean-François Jeu  
Franck Jouet  
Jean-Michel Keroullé  
Vincent Lebaron  
Gilles Lec'hvien  
André Lorin  
Jacques Macé  
Paul Marec  
Anik Margelin  
Jean-François Mariotti  
François Mathieu  
André Meignen  
Jacques Morin  
René Ogor  
Jean Olive  
Gérard Philoux  
Franck Pineranda  
Jean-Claude Pompougnac  
Hugues Priol  
Alain Richard

Michel Roland  
Claude-Youen Roussel  
Michel Vrignaud

## Students

Romain Birot  
Liselore Muis  
Hélène Schillinger

## Associates

Hervé Blanchet - DRSM  
Christophe Cérimo - University of South Brittany  
Dominique Cliquet - SRA  
Basse-Normandie - CReAAH/UMR 6566  
Marie-Yvane Daire - CReAAH/UMR 6566  
Jean-Marie Gallissaire - Iota Survey  
Loïc Langouët - AMARAI  
Guirec Quérré - CReAAH/UMR 6566  
Jean-Philippe Roze - Museum of Saint- Malo

Alkante  
Antechamber Mordelles  
Departmental archives of Ille et Vilaine  
Rance dam  
Cadden  
CCI Saint-Malo Fougères  
CCI Quimper Cornouailles  
Shipyard, Le Charles  
Chatelais and Le Gall, industrial equipment and supplies  
Town Council of Binic  
Town Council of Concarneau  
Rance House  
Museum of Boulogne sur Mer  
Museum of Saint-Malo

Museum harbor of Dunkirk  
Port of Binic  
Port of Concarneau  
Port of St Malo  
Port of Vannes  
Region of Brittany - Port antenna of Saint-Malo  
University of Free Time

## Collège Diwan, Guissény

### Teachers

Dominique Chorlay  
Ffran May  
Jakez Le Borgne  
Hervé Peaudecerf

### Pupils

Shanthi Ambroise  
Thomas André  
Anna Balcon  
Tereza Berrou  
Mariane Bleunven  
Amélie Blonz  
Sezni Boulc'h  
Lorenn Dauzeres  
Erwan Doll  
Ewena Fablet-André  
Aksell Gourhant  
Genovefa Gourvennec  
Tifenn Guegantou  
Keziah Guillope Bodiguel  
Ewen Guiziou  
Helori Hyguinen  
Oanez Kerleroux  
Mathilde Kervran  
Maëlwenn Lautridou  
Loevan Le Borgne  
David Le Breton  
Marie-Hélène Le Duc  
Howel Le Fur  
Ines Le Gall  
Malo Le Gall  
Mael Lecat  
Aurore Lecompte  
Clara Lecompte  
Maël Liziard  
Emilie Monrose  
Gwendal Mosneron Dupin  
Gwennoline Mosneron Dupin  
Yoann Philip

Erwan Quemeneur  
Heidi Richard  
Pierre Riou  
Alan Roignant  
Erwan Roudaut  
Garlonn Vergne

## Special thanks to

Olivier Agogué  
Vincent Barré  
Nicolas Boutet  
Emmanuelle Castel-Granterral  
Philippe Cracosky  
Pascale Delmotte  
Marc Depail  
Christian Fauvel  
Jean-Michel Ferand  
Martial Gabillard  
Michel Glet  
Marie-France Goude-Ayrault  
Nathalie Huet  
Marine Jaouen  
Claude Jeay  
Julien Julhes  
Bruno Lassus  
Ronan Le Baccon  
Jean-Guy Le Floc'h  
Yannick Le Floc'h  
Roland Le Gall  
Jacques Le Lay  
Frédéric Leroy  
Claude Nogues  
Philippe Petout  
Marie-Armelle Paulet-Locard  
Lila Reboul  
Florence Richez  
Serge Rinckel  
Didier Robineau  
Dominique Robineau  
Raymond Sarazin  
Dominique Sevin  
Philippe Thibault  
Arnaud Tréhu  
Pascale Tumoine  
Emilie Veneau  
José Vieira

## *A2S* Belgian team Flanders Heritage Staff

Nico Beernaert  
Wendy Cooremans  
Stefan Corveleyn  
Pieterjan Deckers  
Pascal De Neef  
Ine Demerre  
Kristof Haneca  
Natalie Huyghe  
Det Jacobs  
Glenn Laeveren  
Clint Lenaers (†)  
Tom Lenaerts  
Bart Lippens  
Tine Missiaen  
Evelien Oomen  
Marnix Pieters  
Peter Putteman  
Hans Roeder  
Sven Van Haelst  
Sonja Vanblaere  
Franky Vereycken  
Jeroen Vermeersch  
Valentine Verrijken  
Inge Zeebroek

## Volunteers

Pieter Bax  
Cris Beerens  
Kenneth Beerens  
Roland Beerens  
Dirk Damen  
Willy De Backer  
Hugo De Clerck  
Patrick De Coensel  
Roger Dingens  
Marc Gielen  
Réjane Gyssens  
Claude Lescouhier  
Stefaan Maeckelbergh  
Dieter Maezele  
Christian Mahieu  
Danny Moens  
Alain Muller  
Johan Opdebeeck  
Peter Provost  
Allan Soreyn  
Peter Van der Plaetsen  
Peter Van Schevensteen  
Peter Vandaele

Jessica Vandeveld  
Carine Vercaempt  
Ivan Verkempinck  
Jan Vermeire  
Wim Vermeire  
Hans Vervaeke  
Steve Vervaeke  
Mark Vieren  
Ivan Vosselman  
Alain Witkowski  
Steven Wouters

## Students

Thomas Dhoop  
Rik Lettany  
Liselore Muis  
Sven Van Haelst

## Sint-Bernarduscollege, Nieuwpoort Teachers

Julie Callens  
Diane De Feyter  
Christine Dejonghe  
Wim Jans  
Bernadette Lannoye  
Valérie Vandekerckhove

### Pupils

Ajsa Avdovic  
Elise Casselman  
Manon Casselman  
Fee Crombez  
Jeany Deschacht  
Silke D'Haenen  
Eva Dewulf  
Sarah Vanhoutte  
Emily Verburgh

## Special thanks to

Etienne (†) & Agnès Cools - Mathieu De Meyer  
Glenn Gevaert  
Christian Mahieu  
David Monteyne  
Noordzee Archeologisch Team  
Aquarius vzw



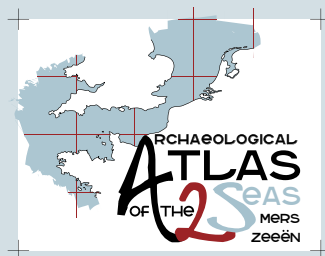

This publication was produced by the partners of the A2S project.

### Editors:

Valerie Fenwick, Alexandre Poudret-Barré, Garry Momber, Ine Demerre, Inge Zeebroek, Amanda Bowens, Cécile Chatelin

### Coordination and graphic design:

Cécile Chatelin

**Authors:** Veerle Ausloos, Amanda Bowens, Cécile Chatelin, Dominique Cliquet, Pieterjan Deckers, Denis Dégez, Virginia Dellino-Musgrave, Ine Demerre, Stephen Fisher, Yann Gaonac'h, Charlotte Georgeault, Jan Gillespie, Joë Guesnon, Django Guyon, Anne Hoyau-Berry, Olivia Hulot, Charlotte Le Noac'h, Brandon Mason, Norbert Mercier, Victoria Millership, Tine Missiaen, Garry Momber, Jean Olive, Alexandre Poudret-Barré, Lauren Tidbury, Élodie Villeneuve, Astrid Vlieberg, Julian Whitewright, Inge Zeebroek

**French translation:** Thierry Bonhomme, Louise Byrne  
**French proofreading:** Valérie Lapalus, Yann Gaonac'h, Django Guyon, Charlotte Le Noac'h, Laetitia Le Ru

**Dutch translation:** Valérie Paquet & Annemie Van den Broucke (GT Traductions/GEA-Consult)

**Dutch proofreading:** Pieterjan Deckers, Ine Demerre & Sven Van Haelst

**Printing:** Pure Impression

### Caption and copyright cover picture:

- First cover in the middle: *Anchors and lime bags on the grindstones shipwreck (FR)*. ©Teddy Seguin / Adramar / A2S (other pictures see inside pages)
- Fourth cover: *Maritime bus in front of Guissény College (FR)*. © HWTMA
- In table of content, top right picture: *Corsairs Captain register © Ille-et-Vilaine Departement Archives-T.Seguin/ADRAMAR/A2S* (other pictures see inside pages).

'This document reflects the author's views. The Financial Partners are not liable for any use that may be made of the information contained therein.'

All rights reserved - June 2012



## Associates

Archaeological museum Waltraversijde  
Open-air museum Atlantic Wall  
Jan Lettens, BVBA Adelante  
The Big Blue crew of 'Ephyra'  
crew of Research Vessel 'Zeeleeuw'  
team of De Kogge, Flanders Heritage  
Agency for Maritime and Coastal Service - Dept. of Coast - Flemish Hydrography  
ORBit, Department Soil Management - Ghent University  
RCMG, Department of Geology and Soil Sciences - Ghent University

## Support

Province of West-Flanders  
Flanders Marine Institute (VLIZ)  
Flemish Government

## A2S English team

**HWTMA President**  
Dame Mary Fagan, JP, HM Lord  
Lieutenant of Hampshire

### HWTMA Vice Presidents

Major-General Martin S. White, CB, CBE, DL, JP, HM Lord  
Lieutenant of the Isle of Wight  
Mr Maldwin Drummond, OBE, DL, Hon DSc, FSA  
The Lord Montagu of Beaulieu

### HWTMA Patrons

Lord Mottistone, CBE  
Mr Michael P. Aiken  
Mr Andrew Williams, OBE  
Mr Alan Titchmarsh, MBE, CMH, DL  
Mr Martin Jay, CBE, DL  
The Hon. Ralph Montagu  
Mr Nicholas de Rothschild, MA  
Mr Christopher D.J. Bland, JP  
Mr Doug Morrison

### HWTMA Management Committee

Cdr. John M. Bingeman, CEng, MIMechE, RN (Chairman)  
Mr Geoff Cadman, MRTPI  
Cllr Peter Eddis, Portsmouth City Council  
Mrs Valerie Fenwick, MA, FSA, MIFA  
Dr Nic Flemming, OBE  
Mr Frank Green, BA, MSc, MPhil, MIFA, IHBC, New Forest National Park Authority  
Mr David E.J. Guy, MBE, JP, DL  
Dr Robin McInnes, OBE, FICE, FGS, FRSA  
Honorary Alderman Michael Woodhall, Hampshire County Council

### HWTMA Staff

Caroline Barrie-Smith  
Amanda Bowens  
Rachel Bynoe  
Kathryn Dagless  
Virginia Dellino-Musgrave  
Stephen Fisher  
Jan Gillespie  
Christin Heamagi  
Brandon Mason  
Victoria Millership  
Garry Momber  
Lawrence Moran  
Gareth Owen  
Julie Satchell  
Lauren Tidbury  
Valentine Verrijken  
Cherryl Whitehead  
Julian Whitewright

## Match funding support

Associated British Ports  
British American Tobacco  
The Crown Estate  
D'Oyly Carte Charitable Trust  
Daisie Rich Charitable Trust  
English Heritage  
Ernest Cook Trust  
Golden Bottle Trust

Gosling Foundation  
Hampshire County Council  
Heritage Lottery Fund  
Institute for Archaeologists  
John Coates Charitable Trust  
Marine Environmental Protection Fund  
National Oceanography Centre  
The Oakmoor Trust  
Robert Kiln Charitable Trust  
Roger Brookes Charitable Trust  
Southampton City Council  
University of Southampton  
West Wight Landscape Partnership

## Special thanks to

Trevor Jenkins, All Dive Video  
Dave Wendes, Wight Spirit Charters  
Dave Robbins  
Hamish Morrison

## The Toynbee School, Eastleigh, Hampshire

With thanks to Mrs Anne Richardson and the staff and pupils of the Toynbee School, Eastleigh, Hampshire

## Norwich School, Norfolk

With thanks to Ella Porter and the staff and pupils of Norwich School, Norfolk

## Volunteers

Amelia Astley  
Mick Awcock  
Delian Backhouse-Fry  
Rosemary Batty  
Darren Baylis  
Carolyn Bell  
Katy Bell  
Jessie Booth  
Robert Bradbury  
Tim Brook

Rowland Brookes  
Mike Cahill  
Derek Callaghan  
Beth Cameron  
Olivia Chalwin  
Pauline Christie  
Nick Cokes  
Mike Cotterill  
Ashley Crossen  
Darwin Culley  
Martin Davies  
Alex Davison  
Sophie Davison  
Laura Davison  
Imogen Davison  
John Elder  
Jim Fuller  
Diane Green  
Clare Hallybone  
Christina Halton  
Christine Harmer  
Jackie Hart  
Sara Hasan  
Jane Hollinshead  
Catherine Holt  
Mari Horsfall  
Russell Ince  
Helen Jackson  
Dave Johnston  
Gareth Jones  
Dominic Kasperski  
Martin Koerner  
Jane Maddocks  
Chris Mason  
Julien Masson  
Emily Jane Masters  
Amy Matthews  
Alison Mayor  
Tony Millership  
Richard Milwain  
Jasmine Noble-Shelley  
Michael O'Sullivan  
Dan Pascoe  
Jan Peters  
Graham Petrie  
Pauline Petrie  
Alan Phillips  
Charlotte Porter  
Amy Radford  
Chris Ratsey  
Giles Richardson  
Georgi Rochford  
Henry Rochford

Julie Snook  
Hannah Stamp  
Paul Tolley  
Ian Underdown  
Anastasia Vasileiadou  
Malcolm Whitewright  
Champika Wijayaweera  
Andy Williams  
Peter Wilson  
Diane Wilson-Greene  
Wendy Wiseman  
Richard Wyatt

## Students

Edward Caplin  
Jocelyne Green  
Lucy Houghton  
Sorna Khakzad  
Leandro Infantini de Rosa  
Andrew Lockett  
Emily Masters  
Amy Matthews  
Amy Radford  
Rebecca Richards  
Tjasha Stroud  
James Troup  
Duncan Robins  
Aaron Ward  
Lynne Westhorpe  
Leanne White  
Jack Wolfe

## Associates

Jolyon Chesworth & Dr Amy Dale, Hampshire and Isle of Wight Wildlife Trust  
Kongsberg GeoAcoustics  
John Liddiard & Max Ellis  
Bjorn Melin, Marna Diving Charters  
Dr Rob Scaife  
Southsea Sub-Aqua Club  
Dr David Tomalin  
University of Birmingham  
Dr Peter Northover, University of Oxford  
Dr Justin Dix & Dr Helen Farr, University of Southampton  
Jason Sadler & Homme Zwaagstra, GeoData Institute,

University of Southampton  
Nigel Nayling, University of Wales Trinity Saint David  
University of York

## A2S documentary

### Written and Produced by

Michael Pitts  
Frank Spencer

### Filmed and directed by

Michael Pitts

### Edited by

Frank Spencer

### Music

Anthony Phillips  
Andrew Skeet

### Diving and Lightning Assistant

John Chambers

### Script Consultant

Anne Shepherd MBE

### Special thanks to

Ron and Pauline Howse  
John Luxford  
Julian Mockford  
Jim Walmsley  
Ann Spencer

# Contacts

## ADRAMAR

ZA La Fontenelle  
35113 Domagné, France  
Phone: +33 (0)9 77 68 50 79  
www.adramar.fr  
contact@adramar.fr

- **Alexandre Poudret-Barré**  
Projects Manager  
alexandre.poudret-barre@adramar.fr
- **Charlotte Georgeault**  
Financial Manager  
charlotte.georgeault@adramar.fr
- **Cécile Chatelin**  
Communication Manager  
cecile.chatelin@adramar.fr

## DRASSM

147 plage de l'Estaque  
13016 Marseille, France  
• **Michel L'Hour**  
Director of the Drassm  
michel.lhour@culture.gouv.fr

- **Olivia Hulot**  
Project Officer  
olivia.hulot@culture.gouv.fr

## HWTMA

Room W1/95  
National Oceanography Centre,  
Empress Dock, Southampton  
SO14 3ZH, United Kingdom  
Phone: +44 (0)23 8059 3290  
www.hwtma.org.uk  
info@hwtma.org.uk

- **Garry Momber**  
Director  
garry.momber@hwtma.org.uk
- **Victoria Millership**  
Administrator and Project Officer  
victoria.millership@hwtma.org.uk

## Onroerend Erfgoed

Koning Albert II-laan 19, bus 5  
B-1210 Brussel, Belgium  
Phone: +32 (0)2/553.16.50  
Fax +32 (0)2/553.16.55  
www.onroerenderfgoed.be  
info@onroerenderfgoed.be

- **Ine Demerre**  
Project coordination  
ine.demerre@rwo.vlaanderen.be
- **Inge Zeebroek**  
Project coordination  
inge.zeebroek@rwo.vlaanderen.be





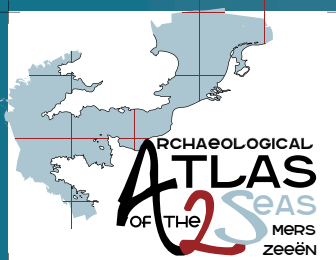

The history of Europe is a tempestuous one. It has been born of invasions, conflicts and political intrigues. These events have divided nations in years gone by. Now, through the A2S project, people from different nations have been linked around a common history, bridging cultural barriers and strengthening relations.

*The Archaeological Atlas of the 2 Seas (A2S)* has emerged from a desire to bring together knowledge, skills and information relating to underwater archaeology in the common maritime areas. It has been an ambitious project that is looking to enhance understanding of our cross-border maritime archaeological heritage. The three countries share a rich submerged maritime heritage that can facilitate collaboration and cross-cultural links.

From 2009 to 2012, A2S partners researched over 150 submerged archaeological sites, collecting data from primary literary sources and national archives. The results have steered a programme of field investigation to explore almost 100,000 years of our collective submerged cultural heritage from prehistoric landscapes to present day shipwrecks.

This report records the process and outcome of the A2S endeavour. It provides case studies presenting the many dimensions of the project while setting out pioneering new methods for dissemination, education and outreach.

The A2S project has been led by the *Association for the Development of Research in Maritime Archaeology* (ADRAMAR) in France, with the *Hampshire and Wight Trust for Maritime Archaeology* (HWTMA) in England and *Flanders Heritage Agency* (Agentschap Onroerend Erfgoed) in Belgium. It has been co-financed by the European Union under the Interreg IV A 2 Seas programme. The work was supported by the *Department of Underwater Archaeological Research and Sub-Marines* (DRASSM) in France, *English Heritage* in England and *Flanders Heritage Agency* in Belgium.

**+ A2S project documentary DVD inside**

