

PAPER • OPEN ACCESS

In-situ checking various mechanical parameters of original nail connections between crossbeams and wooden support, in the framework of an innovative method for rationally dimensioning the crossbeams of panel paintings, applied on an original artwork

To cite this article: MAZZANTI Paola *et al* 2020 *IOP Conf. Ser.: Mater. Sci. Eng.* **949** 012062

View the [article online](#) for updates and enhancements.

239th ECS Meeting

with the 18th International Meeting on Chemical Sensors (IMCS)

ABSTRACT DEADLINE: DECEMBER 4, 2020



May 30-June 3, 2021

SUBMIT NOW →

In-situ checking various mechanical parameters of original nail connections between crossbeams and wooden support, in the framework of an innovative method for rationally dimensioning the crossbeams of panel paintings, applied on an original artwork

MAZZANTI Paola¹, RIPARBELLI Lorenzo¹, GUALDANI Giovanni²,
CASTELLI Ciro², RICCIARDI Luciano², SANTACESARIA Andrea², TOGNI
Marco¹, UZIELLI Luca¹

1 DAGRI (former GESAAF), Univ. Florence, Florence, Italy

2 Opificio delle Pietre Dure, Florence, Italy

The corresponding author's e-mail address: paola.mazzanti@unifi.it

Abstract. A collaboration aiming to improve knowledge and procedures for conservation of Panel Paintings has been in force since several years between OPD (Opificio delle Pietre Dure, Florence) and the Research Group on Wood Technology of DAGRI (University of Florence). In such framework a research is here presented, which for the first time has led to dimensioning rationally (i.e. by means of objective criteria based on Conservation, on Engineering and on Wood Science principles) the stiffness of the crossbeams of an original Panel Painting. Crossbeams typically have a double function: a) to control the deformation of the panel painting when it undergoes climate changes and b) to stiffen the panel painting for handling purposes. If too stiff or too yielding, crossbeams might damage the wooden support or the paint layers; until today the choice of their stiffness was entrusted to the expert but subjective judgment of the Restorers alone, who therefore have been calling for a confrontation with Wood and Engineering Scientists in order to develop more objective criteria. To satisfy this request the research here mentioned has been carried out, in close collaboration between the Restorers of OPD and the Wood Scientists of DAGRI, to develop a specific protocol allowing for the rational dimensioning of the stiffness of crossbeams. This protocol is based on an engineering modular approach, and for the first time it has been applied on an original artwork, the *Adorazione del bambino e committente* attributed to Cesare da Sesto (1514-1520). One of the modules of such protocol is to assess the stiffness of both the crossbeams and the wooden support and, in such framework, this paper presents the non-invasive mechanical tests that were designed and implemented to check in-situ various mechanical parameters (including the axial holding capacity) of the original nail connections between the crossbeams and the wooden support. Such knowledge might in general be helpful especially during the diagnostic phase, to understand the internal forces still acting into the wood structure, and possibly their influences on the degradation of the paint layers in relation to the behaviour of the wooden support.



1. Introduction

Even if a work of art must be considered an inseparable unit, for diagnostic and conservation purposes a panel painting can be considered as composed of a wood structure on which paint layers (including ground layers) are applied. The wood structure is typically composed of (i) a wooden support or panel (a planking) on which the paint layers are applied, equipped with (ii) a restraining system, e.g. frame and/or crossbeams; the interaction between the wooden support and the restraining system is nowadays considered of key importance for an optimal conservation of panel paintings. The already active collaboration between DAGRI (University of Florence) and Opificio delle Pietre Dure (OPD) laboratory has been focused on this topic in the framework of a restoration work on *Adorazione del Bambino e committente* attributed to Cesare da Sesto, 1515-1520 (Figure 1), that was the subject of a final degree thesis at SAFS (OPD) [1].

The planking is 137 cm wide, 213 cm high and 3.5 cm thick, made of three poplar boards (*Populus alba* L.) glued along their edges; the restraining system is made of three chestnut crossbeams (*Castanea sativa* Mill.) nailed to the planking. The boards are of poor quality, two are flat sawn and the other one is quarter sawn with pith included. The crossbeams, all with pith included, had a variable section; their width was 11.0 cm for the two extreme ones and 9.0 cm for the central one, their thickness was variable (5 cm approximately) for each of the crossbeams and within each one because of some hand-made thickness reductions. This operation was performed at some point by artisans or restorers who had presumably realized that the original crossbeams were too stiff. Nowadays, the OPD Restorers highlighted the same problem, since they observed a significant condition of suffering due to the still excessive stiffness of the crossbeams together with the repeated climatic variations. In fact, the wooden support showed several cracks, and an open joint between two boards at its top; in addition buckling, cleavage and flaking were observed on the paint layers. Thus, the OPD Restorers drafted a restoration plan that included a better-suited design for the crossbeams. For the first time, such dimensioning was made in collaboration with the Wood Technologists from DAGRI, a collaboration that led to develop and implement a new protocol for the dimensioning of the crossbeams; for the details regarding the protocol see [2]. The protocol consists of the following five “modules”: a) a Restoration Plan, developed by Restorers and Conservators, providing Wood Technologists with information about the desired restraining effect that crossbeams should exert for the artwork’s optimal conservation, b) appropriate mechanical tests to evaluate the stiffness of the painted panel and of the crossbeams, c) hygroscopic tests to determine the hygromechanical behaviour of the wooden support alone, d) dimensioning the new crossbeams by means of numerical modelling and e) numerical and/or experimental verification of the dimensioning. One of the modules of such protocol included the measurement of the mechanical behaviour of the wood structure; in this regard, some non-invasive and absolutely safe mechanical tests were allowed. The main purposes of these mechanical tests were to assess a) the transversal bending stiffness of the wooden support, b) the longitudinal bending stiffness of each crossbeam and c) to check the axial holding capacity of the nails connecting the crossbeams to the wooden support. This last point was of great interest for the Restorers, both for diagnostic reasons and for planning their intervention; this is therefore the topic on which this paper is centred.

As mentioned above, in the framework of the pre-intervention diagnostic phase, before planning their modification and their adaptation to the new restraining system, the Restorers needed to understand and evaluate both a) the interactions between crossbeams and the wooden support, and b) the holding capacity of the nails.

Indeed, the tests described here are basically configured as simple “proof-load” tests, aiming to ensure that the in-situ original nails can withstand the design load anticipated by the numerical modelling (not dealt with here) without failure nor irreversible deformation.

Additionally, performing these tests made it possible to better understand the physical behaviour of the original wood structure and the damages it might have produced on the paint layers, and to measure various mechanical parameters of the connection, including a) the residual restraining load, if any, still exerted through the nail between the wooden support and crossbeam, b) the forces (if any, possibly caused by “friction”, “adhesion” or “encrustation”), that oppose the slippage of the nail shank with respect to the crossbar’s wood it crosses, and c) the elastic behaviour of the wooden support in transverse bending, at the time of testing (these tests were performed before the wooden support was separated from the crossbeams to restore its structural integrity).

However, it should be acknowledged that although such information can generally contribute to a better understanding of the involved phenomena, in this specific case it was not needed, and therefore has not been used, for the rational design of the new restraining system.



Figure 1 The original artwork *Adorazione del Bambino e donatore* attributed to Cesare da Sesto, 1515-1520; both the front (painted) face and the back face after restoration are shown.

2. Materials and Method

In order to measure the above-mentioned mechanical parameters, a made-on-purpose measurement method, and a simple apparatus for putting it into practice were designed and implemented, suitable for the complex task of performing the measurements on an original artwork in a restoration laboratory.

The method consisted in a) applying a pull-out axial force to the nail’s head, b) applying the reaction to such force against the crossbeam, and c) measuring the slippage of the nail with respect to the crossbeam.

The measuring apparatus consisted of the following elements (see Figure 2):

- a stiff U-shaped wooden bridge, placed on the crossbeam above the nail to be measured (the contact areas being regularized by means of wood-epoxy wedges, built on site for each location, simply resting on the crossbeam without being glued to it);
- a load cell (LAUMAS AZ010, full-scale 1000 N, error 0.2% full-scale), fixed on the wooden bridge so that its measurement axis is aligned with the nail;
- a threaded bar (equipped with a handle at one end, and a lifting shackle with free-rotating bearing on the other), engaged in a threaded hole in the load cell, and aligned with its measurement axis;
- a steel wire cage built on the nail’s head, grappled to the lifting shackle;
- two potentiometric linear transducers (Penny&Giles, SLS095, error ± 0.25 %), measuring the displacement between nail (in fact, the planking on which the nail is planted and clinched) and

crossbeam; being mounted on the two sides of the crossbeam, they take into account any asymmetry during the test.

Slowly rotating the threaded bar by means of the handle, resulted in pulling or releasing axially the nail.

The data were logged every second by means of Onset HOBO UX120-006M (resolution $40 \mu\text{V}$, accuracy $\pm 0.1 \text{ mV} \pm 0.1 \%$ of reading). In order to remain safe, the test was stopped when a maximum force of 500 N was applied.

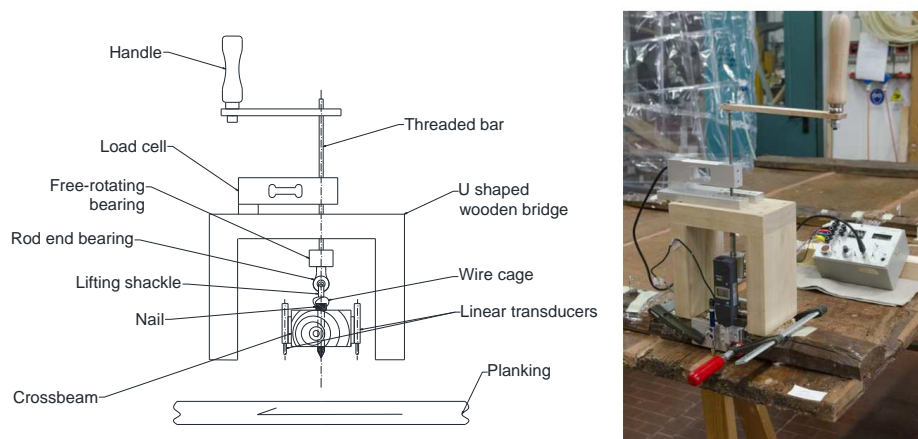

Figure 2 The drawing of the measurement apparatus, applied on nail A2 (see Figure 3). From top to bottom, the components are visible: handle, threaded bar, load cell, wooden bridge-support, free-rotating bearing, rod end bearing, lifting shackle, wire cage built on the nail's head, potentiometric displacement transducers mounted on metal plates fixed on the crossbeam's sides. The drawing is a schematic image of the test method showing all the components, dimensions are not realistic; when the handle is rotated, the nail is pulled or released. The photo shows the measurement apparatus mounted on the original artwork in the restoration laboratory; also two digital centesimal comparators were added in parallel to the transducers in order to have comparison measurements.

Firstly, some tests were performed on a mock-up panel, to verify the correct operation of the measurement apparatus and to reproduce situations that may occur on the artwork. In fact, two possible situations were reproduced, both with the nail free to move through the crossbeam: one with no preload and the other one with the nail preloaded by a force of known entity; later the results made it easier to interpret the tests on the original artwork.

Five original nails were then non-destructively tested in-situ (see Figure 3): two on the upper crossbeam (A2 and A5), two on the central crossbeam (B2 and B4), one on the lower crossbeam (C2).

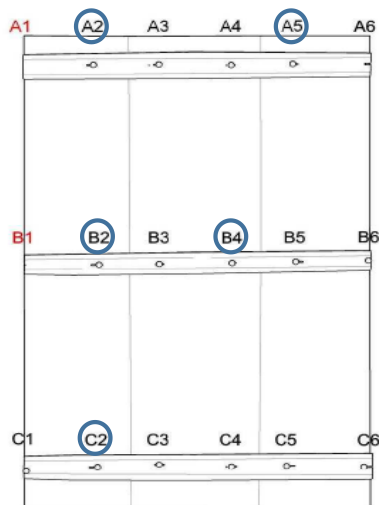

Figure 3 Schematic drawing of the back of the panel painting, showing the locations of all the nails. Nails A1 and B1 are no longer present, their existence was only hypothesised. The tested nails are circled.

3. Results and Discussion

All the data were organized in force-displacement graphs, the displacement was computed as the average of the displacements measured by the two potentiometric transducers.

The tests on the mock up provided clear and useful data as shown in Figure 4. When the not preloaded nail was tested, the graph shows a linear correlation between the displacement and the force, produced by the transverse flexural deformation of the wooden support; on the other hand, when the preloaded nail was pulled out, an initial phase of quickly increasing force with almost no displacement occurred, followed by a linear less steep phase, after the preload was exceeded.

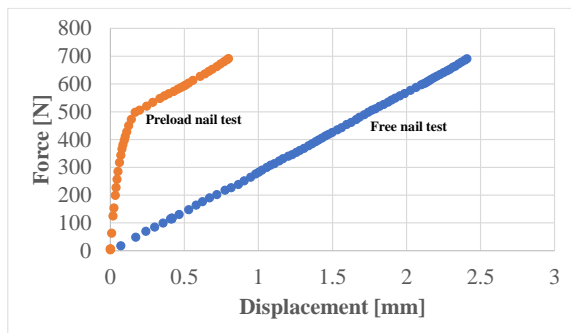

Figure 4 The graphs show the tests performed on the mock-up panel. The blue curve was observed when a not preloaded nail (“free nail”) was pulled out; the orange curve resulted from a preloaded nail.

Comparable results were observed on the original artwork as in Figure 5, which shows the test on nail B2. The graph shows a linear correlation between the force and the displacement, which highlights a not preloaded nail, free to move through the crossbeam; again, the displacement is produced by the transverse flexural deformation of the cupped wooden support, pulled by the nail against the crossbeam.

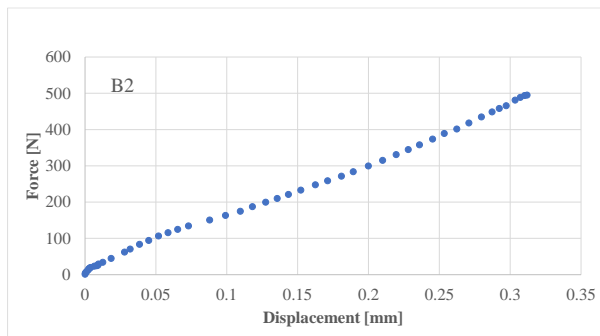

Figure 5 The graph shows the pull-out test on nail B2. In this case the nail was free to move through the crossbeam (the graph shows no initial steep increase of the force, which would be caused by friction or adhesion between nail shank and crossbeam), and a linear correlation is observed between the force and the displacement.

In Figure 6 two situations similar to each other (nails A5 and B4) are presented, recalling the mock-up tests with preloaded nails. In this case, the nails showed a preload of about 200 N. However, here the transition between the two phases (initial part: overcoming the preload – final part: bending of the wooden support) is not clearly defined. The straight segments in Figure 7 represent the ideal trend assumed for the graphs, in the absence of adhesions or frictions.

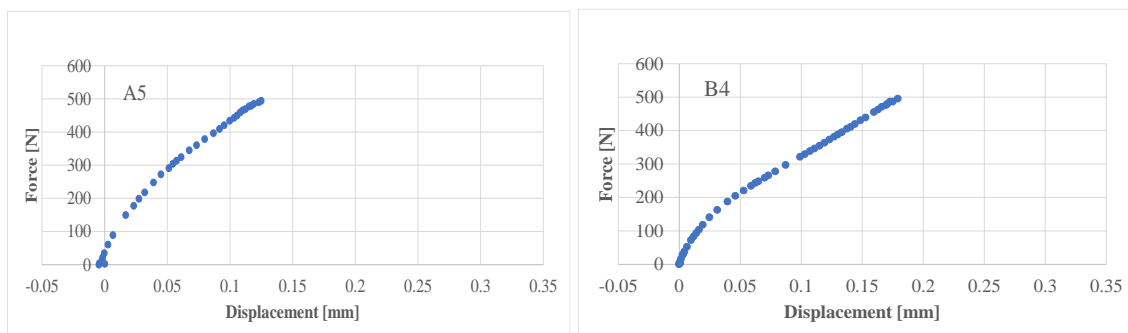

Figure 6 The graph shows the pull-out test of nails A5 and B4. Both the tests show a steep initial phase (up to around 200 N) at the end of which the preload was reached; presumably the curved trend of that part of the graphs indicates the presence of friction and / or deformation of the nail shanks. After the preload limit is exceeded, the smaller slope indicates the nails were freely slipping through the crossbeams, and the wooden support was deforming in transversal bending.

In order to determine a specific preload value for each nail, the following method is chosen. The curve was ideally divided in two parts according to the changing slope observed during the test: a first part made of 7-9 data representing the preload reaching phase and a second part made of 11-15 data, extrapolated from the central part of the transversal bending phase. For each of these two parts, a trend line was calculated by means of Excel and the equations are reported in Figure 7. Therefore, a system of two equations in two unknown variables is obtained and its solution gives the computed preload value (see the orange circles in Figure 7). For nail A5, the solution gives a preload value of 209 N; probably the main reasons for the divergence between the experimental curve and its schematization with two segments consists in some friction and/or shank deformation and/or lateral yielding of the crossbeam's wood. Such phenomena are more evident than for nail B4 and, as a consequence, the computed value for the displacement (0.02 mm) does not approximate the experimental one (0.03 mm). However, it is possible to identify a preload value that belongs to the curve and best approximates this experimental test, which probably is 177 N. The same method applied to nail B4 gives a solution of 157 N, which once again does not belong to the curve, but lays close to it both for displacement (same value) and force (the difference is 15 N, probably due to the friction).

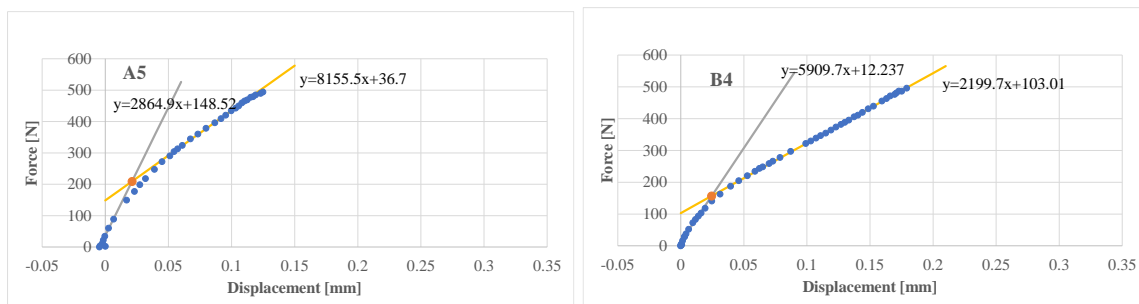

Figure 7 The graphs show a method to determine the possible preload value. Two different trend lines are calculated for each curve, one for the “preload phase” and a second one for the “transversal bending” part; the solution of the system of equations gives the preload value, in the graphs, the computed preload value is represented by an orange circle. The values are 209 N for A5 (which shows a divergence from the experimental data probably because it is influenced by friction or deformation of the nail shank) and 157 N for B4.

Lastly, the nails A2 and C2 (Figure 8) show a completely different behaviour, indeed the force-displacement curves are characterised by one only very steep phase, that is, a rapid growth of force, in correspondence with very limited displacements. This behaviour is interpreted as a consequence of completely blocked nail shanks into the crossbeams.

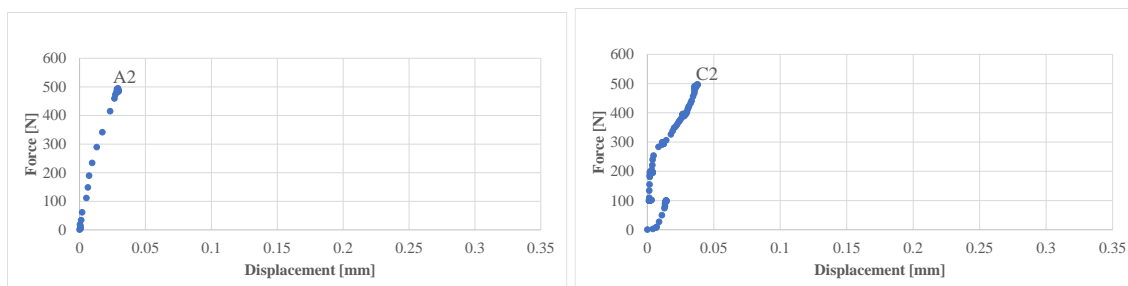

Figure 8 The graphs show the pull-out test of nails A2 and C2. Both the tests showed very steep curves, possibly due to the nail shanks completely blocked into the wooden crossbeams.

4. Conclusions

The experimental tests described here are particularly significant in that they have been carried out non-invasively on an original artwork in the restoration laboratory. They were planned and implemented by means of a made-on-purpose measurement method and apparatus, intended for measuring the load-displacement behaviour of original nails present in an original panel painting.

The results highlight that some nails were still transmitting a force between the wooden support and the crossbeam, whereas others were totally unloaded; also, some nail shanks were completely blocked against the crossbeam, whereas others were completely free. Such knowledge might in general be helpful especially during the diagnostic phase, to understand the internal forces still acting into the wood structure and possibly their influences on the degradation of the paint layers in relation to the behaviour of the wooden support and the crossbeams.

Moreover, the tests performed constituted a sort of proof-loading, verifying that the original nails were able to withstand in operation a pull-out force of at least 500 newtons.

References

- [1] Gualdani G. (2017). Il caso studio del dipinto su tavola Natività di Cesare da Sesto. Un lombardo nel Rinascimento meridionale all’inizio del XVI secolo: particolarità tecniche e costruttive. Analisi sul

degrado della pellicola pittorica in relazione al comportamento del supporto ligneo. L'intervento di restauro della tavola. Tesi di laurea alla SAFS - Scuola di Alta Formazione e di Studio dell'Opificio delle Pietre Dure di Firenze [The case study of the panel painting Nativity by Cesare da Sesto. A Lombard in the southern Renaissance at the beginning of the 16th century: technical and constructive peculiarities. Analysis on the degradation of the paint layers in relation to the behavior of the wooden support. The structural restoration of the panel painting. Final Degree Thesis at SAFS - Higher Education and Study School, in the OPD - Opificio delle Pietre Dure, Florence]

[2] C. Castelli, G. Galdani, L. Gusmeroli, P. Mazzanti, L. Riparbelli, A. Santacesaria, M. Togni, L. Uzielli, (2018). Il restauro del supporto ligneo della Natività attribuita a Cesare da Sesto. Messa a punto di un metodo per il dimensionamento e l'adeguamento elastico della traversatura originale. [Conservation of the wooden support of the Nativity attributed to Cesare da Sesto. Definition of a method for dimensioning and adjusting the flexibility of the original crossbeams system], OPD Restauro 30: 186-204

[3] Pieroni F. (2017). Alcuni aspetti della funzionalità del collegamento mediante chiodi tra traversa e tavolato: prove non invasive durante il restauro di un dipinto del Cinquecento, e prove di resistenza all'estrazione di vecchie chiodature sacrificabili. Elaborato finale per la laurea triennale in Diagnostica e Materiali per la Conservazione e il Restauro, Università di Firenze [Some aspects of the performance of the nailed connection between crossbeam and painted panel: non-invasive tests during the restoration of a sixteenth century painting panel, and pull-out tests of expendable nails. Final Report for the Three-years Degree in Diagnostics and Materials for Conservation and Restoration, University of Florence].