

Available online at www.sciencedirect.com**ScienceDirect**

Procedia Engineering 87 (2014) 1314 – 1317

**Procedia
Engineering**www.elsevier.com/locate/procedia

EUROSENSORS 2014, the XXVIII edition of the conference series

Enzymatically catalyzed degradation of biodegradable polymers investigated by means of a semiconductor-based field-effect sensor

S. Schusser^{a,b}, M. Bäcker^{a,b}, M. Krischer^a, L. Wenzel^a, M. Leinhos^{a,b}, A. Poghosian^{a,b},
M. Biselli^a, P. Wagner^c, M.J. Schöning^{a,b*}

^aInstitute of Nano- and Biotechnologies (INB), FH Aachen, Heinrich-Mußmann-Straße 1, 52428 Jülich, Germany

^bPeter Grünberg Institute (PGI-8), Forschungszentrum Jülich GmbH, Wilhelm-Johnen-Straße, 52428 Jülich, Germany

^cInstitute for Materials Research, Hasselt University, Wetenschapspark 1, 3590 Diepenbeek, Belgium

Abstract

A semiconductor field-effect device has been used for an enzymatically catalyzed degradation of biopolymers for the first time. This novel technique is capable to monitor the degradation process of multiple samples in situ and in real-time. As model system, the degradation of the biopolymer poly(D,L-lactic acid) has been monitored in the degradation medium containing the enzyme lipase from *Rhizomucor miehei*. The obtained results demonstrate the potential of capacitive field-effect sensors for degradation studies of biodegradable polymers.

© 2014 The Authors. Published by Elsevier Ltd. This is an open access article under the CC BY-NC-ND license (<http://creativecommons.org/licenses/by-nc-nd/3.0/>).

Peer-review under responsibility of the scientific committee of Eurosensors 2014

Keywords: Field-effect sensor, enzymatic (bio)degradation, poly(d,l-lactic acid), in-situ monitoring, impedance spectroscopy

1. Introduction

An accurate prediction of degradation kinetics of biodegradable polymers is essential for the application of such materials in biomedical products. The degradation rate is defined not only by the chemical nature of the degradable backbone and physico-chemical properties of the polymer [1–3], but also the physico-chemical parameters of the degradation environment [4] or the addition of compounds for drug-release applications can have an impact on the

* Corresponding author. Tel.: +49-241-6009-53235; fax: +49-241-6009-53235.
E-mail address: schoening@fh-aachen.de

degradation kinetics [5]. As a consequence, extensive studies on the mechanism and influencing factors are inevitable to understand the degradation process in detail. Common techniques for the study of a degradation of biopolymers, such as gel permeation chromatography, weighing of the mass loss, or nuclear magnetic resonance [6,7], are costly and laborious and consequently, make a total investigation an unfeasible endeavor due to the limited throughput of test samples. Recently, a sensor-based technique utilizing semiconductor field-effect devices has been introduced for degradation monitoring of biopolymers [8]. These devices consist of an electrolyte-insulator-semiconductor (EIS) structure and are able to detect not only interfacial potential changes induced by ions, enzymatic reactions or charged macromolecules [9–12], but also changes in thickness or permittivity of polymer layers deposited on EIS surfaces. Since this approach provides an electrical signal indicating the state of the degradation process, it is capable to monitor the degradation process of a large number of samples in-situ and in real-time.

Poly(lactic acid) (PLA) is one of the most important biodegradable polymers for biomedical applications. One major reason is the fact that PLA degrades to lactic acid, which is a natural component of the anaerobic metabolism of animal and human bodies. Thus, it can leave the organism via a natural pathway. Due to the exceptional importance of PLA, it was chosen as a model polymer for the present work. The functional group of PLA is an ester, which is degraded by means of a hydrolytic splitting in the presence of water. It is known that the rate of this splitting process can be altered by a large number of factors such as the surrounding pH, temperature, ionic strength or enzymes present in a biological environment. In the present work, the enzymatically-catalyzed degradation of PLA was monitored by the field-effect sensor. The degradation process was accelerated and triggered by means of the enzyme lipase from *Rhizomucor miehei* (LipaseRM) [13].

2. Materials and methods

2.1. Sensor structure and signal read-out

The developed sensor consists of a p-doped silicon substrate with an insulating layer of 30 nm SiO₂ and 60 nm Ta₂O₅ on top, and 300 nm Al on the rear-side forming an ohmic contact. The polymer under investigation was applied on the insulating layer as a thin film by means of a spin-coating method (see Fig. 1). The thickness can be adjusted by varying the concentration of the polymer in the solvent as described in [8]. The sensor surface covered

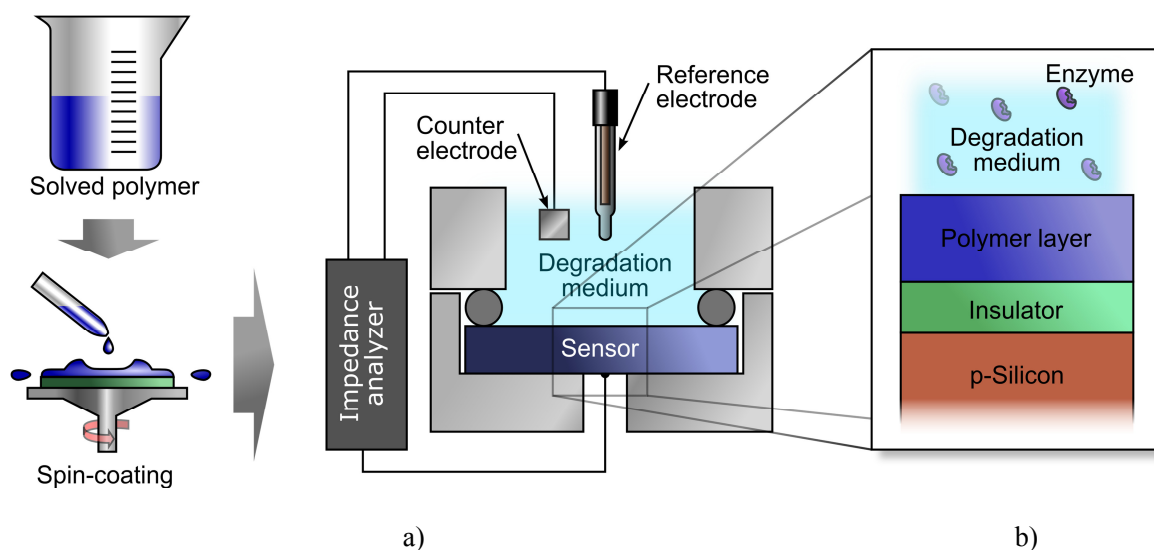

Fig. 1: Illustration of the experimental setup using a semiconductor field-effect sensor for monitoring polymer biodegradation (a), and detailed schematic of the sensor structure covered with a polymer layer (b).

with the polymer film was sealed with an O-ring in a home-made measurement cell containing the degradation medium. The sensor signal was read-out using an impedance analyzer (IM6, Zahner Elektrik GmbH, Germany). A DC bias potential of -2 V vs. the Ag/AgCl reference electrode was applied to the sensor structure to operate the device in the accumulation region. In this working mode, the capacitance of the field-effect sensor is independent on the applied voltage and defined by the gate capacitance. Further details on the relation of the working mode and the bias potential as well as the functional principle of the field-effect device in general is described elsewhere [14]. For the read-out, an AC signal with frequencies of 0.1 Hz to 1 MHz and an amplitude of 20 mV is superimposed in order to determine the complex impedance of the system, including sensor, polymer layer and electrolyte. A full impedance spectrum was captured every hour.

2.2. Polymer and enzyme

The experiments on the enzymatic degradation of the polymer were carried out using the commercial poly(D,L-lactic acid) Resomer[®] R202H (Evonik Röhm GmbH, Germany), with an isotactic order of the two enantiomers L- and D-lactic acid and a mass-average molar mass of $M_w=10,000-18,000$. The polymer was solved in methyl ethyl ketone (MEK) with a concentration resulting in a layer thickness of 500 nm after spin-coating. The covered sensors were mounted in separate measurement chambers and were exposed to different degradation media composed of either the pure pH 7 buffer (Titrisol[®], Merck KGaA, Germany) or the buffer containing the enzyme LipaseRM (Palatase[®] 20000L, Novozymes A/S, Denmark). The enzyme was diluted 1:500 in pH-buffer solution and both degradation media were adjusted with respect to the conductivity by adding KCl.

3. Results and discussion

Figure 2 shows the normalized time-resolved sensor signal derived from the captured impedance spectra at a fixed frequency of 100 Hz. The signal was normalized to avoid sensor-related variances of the measured impedance caused by tolerances of the insulator thickness and sensitive area.

The impedance signal of the sensor exposed to pH 7 buffer exhibits an initial phase during which the impedance decreases until it reaches an almost steady condition. This behavior is similar to former studies on polymer degradation in pH 7 using this sensor technique. This process can be due to water penetration or related ion diffusion into the polymer bulk. Strictly speaking, it is not associated to degradation in chemical terms but gives information about fundamental processes that mainly define the degradation kinetics. In this respect, the polymer exposed to pH 7 exhibits slow degradation indicated by the high level of the sensor signal even after 12 days of exposure. In

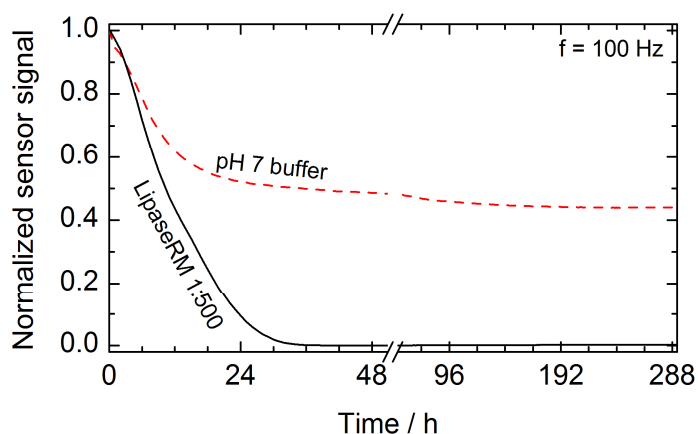

Fig. 2: Normalized signals of sensors exposed to media composed of either pure pH 7 buffer or buffer containing the enzyme LipaseRM.

contrast, the signal of the polymer exposed to the medium containing the enzyme showed a monotonic decrease of the sensor signal and reached the level of the bare sensor after 36 hours.

4. Conclusion

A detailed knowledge concerning the degradation behavior of biodegradable polymers is essential for an expedient and save usage. In this respect, external influences need to be identified and investigated in detail. The successfully performed experiments on the enzymatically catalyzed degradation of poly(D,L-lactic acid) demonstrate the potential of capacitive field-effect sensors as a novel and promising tool for the real-time, in-situ electrical monitoring of degradation kinetics of polymer layers. Its capability to monitor a large number of samples in-situ at the same time facilitates performing extensive studies on multiple parameters without great effort.

Acknowledgements

This research is part of the Interreg EMR IV-A project BioMIMedics (www.biomimedics.org) and is co-financed by the European Union, local governments, research institutes and SMEs. The European Commission, investing in your future.

References

- [1] P. Gunatillake, R. Mayadunne, R. Adhikari, Recent developments in biodegradable synthetic polymers, in: M.R. El-Gewely (Ed.), Elsevier, 2006: pp. 301–347.
- [2] N. Lucas, C. Bienaime, C. Belloy, M. Queneudec, F. Silvestre, J.-E. Nava-Saucedo, Polymer biodegradation: Mechanisms and estimation techniques - A review, *Chemosphere* 73 (2008) 429–442.
- [3] D.F. Williams, S.P. Zhong, Biodeterioration/biodegradation of polymeric medical devices in situ, *International Biodeterioration & Biodegradation* 34 (1994) 95–130.
- [4] F. von Burkersroda, L. Schedl, A. Göpferich, Why degradable polymers undergo surface erosion or bulk erosion, *Biomaterials* 23 (2002) 4221–4231.
- [5] F. Alexis, Factors affecting the degradation and drug-release mechanism of poly(lactic acid) and poly[(lactic acid)-co-(glycolic acid)], *Polymer International* 54 (2005) 36–46.
- [6] W. Amass, A. Amass, B. Tighe, A review of biodegradable polymers: uses, current developments in the synthesis and characterization of biodegradable polyesters, blends of biodegradable polymers and recent advances in biodegradation studies, *Polymer International* 47 (1998) 89–144.
- [7] R. Auras, L.-T. Lim, S.E.M. Selke, H. Tsuji, eds., *Poly(Lactic Acid): Synthesis, Structures, Properties, Processing, and Applications*, John Wiley & Sons, Inc., New Jersey/Canada, 2010.
- [8] S. Schusser, A. Poghossian, M. Bäcker, M. Leinhos, P. Wagner, M.J. Schöning, Characterization of biodegradable polymers with capacitive field-effect sensors, *Sensors and Actuators B: Chemical* 187 (2013) 2–7.
- [9] M.H. Abouzar, A. Poghossian, A.G. Cherstvy, A.M. Pedraza, S. Ingebrandt, M.J. Schöning, Label-free electrical detection of DNA by means of field-effect nanoplate capacitors: Experiments and modeling, *physica status solidi (a)* 209 (2012) 925–934.
- [10] J. Gun, M.J. Schöning, M.H. Abouzar, A. Poghossian, E. Katz, Field-effect nanoparticle-based glucose sensor on a chip: amplification effect of coimmobilized redox species, *Electroanalysis* 20 (2008) 1748–1753.
- [11] A. Poghossian, D.T. Mai, Y. Mourzina, M.J. Schöning, Impedance effect of an ion-sensitive membrane: characterisation of an EMIS sensor by impedance spectroscopy, capacitance-voltage and constant-capacitance method, *Sensors and Actuators B: Chemical* 103 (2004) 423–428.
- [12] M.J. Schöning, N. Näther, V. Auger, A. Poghossian, M. Koudelka-Hep, Miniaturised flow-through cell with integrated capacitive EIS sensor fabricated at wafer level using Si and SU-8 technologies, *Sensors and Actuators B: Chemical* 108 (2005) 986–992.
- [13] Y. Takahashi, S. Okajima, K. Toshima, S. Matsumura, Lipase-catalyzed transformation of poly(lactic acid) into cyclic oligomers, *Macromolecular Bioscience* 4 (2004) 346–353.
- [14] A. Poghossian, M.J. Schöning, *Encyclopedia of Sensors*, in: E.C. C.A. and Dickey Grimes, M.V. Pishko (Eds.), American Scientific Publisher, 2006: pp. 463–534.