



Indian Journal of Pure & Applied Physics  
Vol. 58, September 2020, pp. 698-705



## New hand-cart for Old-Delhi whole sale market designed and engineered using generic product development process

Amol & Sangeeta Pandit

Indian Institute of Information Technology Design and Manufacturing, Jabalpur 482 005, India

*Received 21 July 2020; accepted 30 July 2020*

The study aimed to design a hand cart for the cart puller in the old Delhi area. We used a Generic Product Development Process as a base to design and test our new cart design for the cart pullers. The process had been used in a sequential procedure to get the best design solution. It also saves time and money which would be wasted in the reiteration of the cart design. It starts with User Research where we find out the basic user needs, which can be conducted via interview. Then to convert the user needs into applicable design specifications, we used a Quality Function Deployment (QFD). The next stage was to design the concepts, to do so we used the Morphological chart which helped us to generate concepts logically. After the generation of concepts, we had to select one concept which is the most promising one, to do so we used Pugh's Concept Selection method and we landed on one concept. To make the detailed design of the cart we used dimensions from the existing cart and used Indian anthropometric data to add ergonomics into the cart design. A 3D CAD Design was made using detailed dimensions. Finally, based on CAD design a low fidelity prototype was made, and then it was translated into a 1:1 scale prototype. The last stage of testing was done and results were compared with the existing cart design in terms of Rapid Entire Body Assessment (REBA), Hierarchical Task Analysis (HTA) and Verbal interview.

**Keyword:** Hand cart, Generic product development process, Quality function deployment, Morphological chart, Pugh's concept selection, CAD, Indian anthropometry, Ergonomics, Rapid Entire body assessment (REBA), Hierarchical task analysis (HTA)

### Introduction

In our day to day life, we do all sorts of material handling jobs. Any action where there is transporting or supporting of a load by one or more than one person it is referred to as manual material handling<sup>1,2</sup>. In almost all working environments, manual handling occurs. It can include lifting boxes at an assembly or packaging line, construction materials handling, pushing or pulling carts, handling of patients in the hospitals, cleaning, etc. The prolonged or incorrect posture of manual material handling can result in Work-related Musculoskeletal Disorders (WMSD)<sup>2</sup>. Work-related Musculoskeletal Disorder may include injuries in the back, neck, shoulder, arms, or other body parts. Also, there are chances of cuts, bruises, fractures along with damage to the musculoskeletal system of the body (muscles, tendons, ligaments, bones, joints, blood vessels, and nerves). Sometimes improper material handling results in unexpected events such as accidents. From the dawn of civilization, humans have been trying to find ways for

transporting goods and people from one point to another. We have found pieces of evidence of the first 2 wheeled carts in Mesopotamia around 3000 BCE<sup>3</sup>, which was a breakthrough in freight transportation in human civilization. From there till mid seventeens the use of different types of carts and wagons was on the major source of transportation. These carts were propelled by either humans or animals<sup>3</sup>. Today we have categorized vehicles in two parts, Motorized Transportation (MT), and Non-Motorized Transportation (NMT). Motorized Transportation is considered the best option for long haulages while Non-Motorized Transportation (NMT) is good for a shorter run as they are non-polluting and more economical. The use of NMT's has been increasing around the globe. Countries like Spain, Italy, Switzerland, Rwanda, etc. have been using NMTs as an economical and environmentally friendly alternative<sup>4-6</sup>. Even in our country carts are seen everywhere, From railway station to vegetable vendor to dabbawallas in Mumbai<sup>7</sup>. In Delhi the hand-pulled cart and their pullers are known as "Thella & Thella Walla's", they are the backbone of transportation of goods in the old Delhi area. As mentioned above pushing or pulling of

\*Corresponding author:  
(E-mail:1814005@iiitdmj.ac.in)

carts is considered a manual material handling task, the hand carts are widely used for last-mile delivery

The hand-pulled cart or hand cart is a play a vital role in connecting business. The hand cart is one of the most important Non-Motorized Transports (NMT) when compared with animal carts, cycle thela, and head load porters. In the Old Delhi area, it has been seen that 37,425 tonnes of goods are transported between major markets, they are food grains, textiles, automotive parts, hardware material, and electrical materials markets, which results in 160948 tonnes km of movement via the motorized and non-motorized mode of transportation. Now out of 37425 tonnes, 20,659 tonnes are transported via non-motorized vehicles that account for a little over 55%. Out of 55%, 34.4% comes from hand carts which accounts for 12,860 tonnes per day<sup>8</sup>. They are highly efficient as they can fit in narrow roads still carrying heavy loads, they are non-motorized therefore they don't cause any harm to the environment and the hand cart's operational costs are much lower as compared to Light Commercial Vehicles.

The hand carts are no doubt one of the best options for last-mile delivery but there are a lot of problems associated with cart pulling operation. The cart's design is such that every time the cart needs to be moved with or without load the cart puller has to come in front of the cart, kneel and put on a shoulder strap with which the cart pullers lifts the cart. After this stage, the cart puller holds the handles and lifts the cart using his arms and shoulders to relieve some pressure off the shoulder and starts walking (Fig.1). If the load is heavy then the cart puller also uses one of his shoulders which was previously strapped to pull the load. To do this kind of heavy (up to a ton) manual material handling task, the puller uses immense force to complete the cart pulling operation *see Fig 2*. Moreover, the hand carts are estimated to carry 70,542 Tonne Km which is equivalent to an estimated 16,940 vehicle Km<sup>8</sup>.

### Methodology

To design and develop a new cart that would reduce the physiological load on the body cart puller, we had used the Generic Product Development Process (GPDP). The Generic Product Development Process is a sequential process which follows these steps:

#### Identify customer needs

According to the book<sup>9</sup>, it has been given that the interviews are one of the best information-gathering

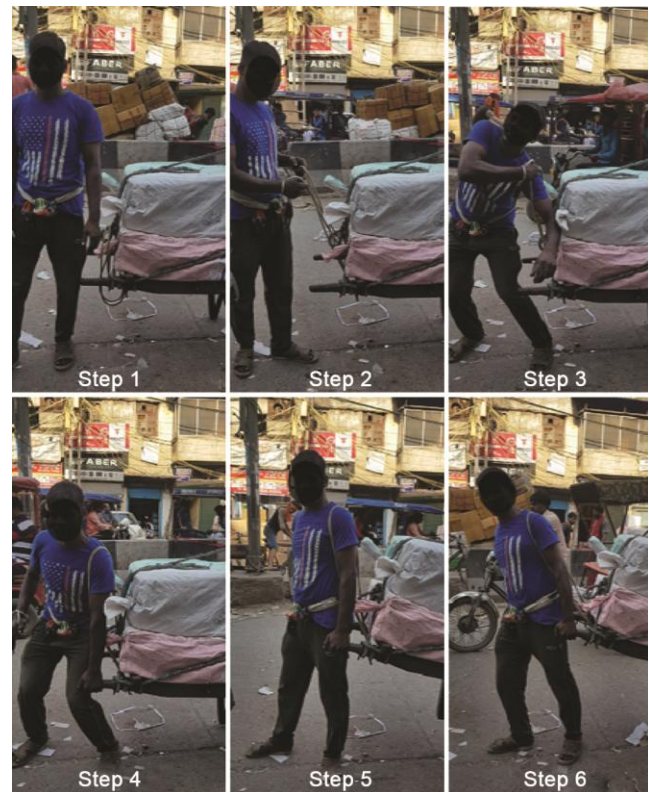

Fig. 1 — Task analysis of cart puller.



Fig. 2 — Cart pulled with help.

tools available for research; it is done to draw out the user's view about a particular task or job at hand. The interviews are generally dyadic and can sometimes have preplanned questions or sometimes impromptu. Interviews are one of the best tools for the market survey as they are quick and don't require much equipment. To understand the user need and pain points, the interviews we conducted were majorly on four groups i.e., the cart pullers, transporters, shopkeepers, and cart manufacturers and suppliers.

### Set target specifications

The Quality function Deployment (QFD) is a method that was designed by Dr. Yoji Akao at the beginning of 1966<sup>10</sup>. This tool converts customer needs or user demands into tangible engineering characteristics. To start with QFD one must have done prior research on the problems faced by the user and one must come up with a list of on-point user requirements to be used in QFD. The QFD is a way in which an engineer or anyone in front end development of a product or a policy can understand and convert the user needs which are considered as “what’s” (what the user wants) into engineering characteristics which may be relevant to those desires which are also known as “How’s” (how to bring demands into tangible output). The QFD prioritizes each product characteristic while simultaneously setting development targets. The result of the Quality function Deployment is generally a matrix with user demands on one side and is correlated with functional requirements on the top side. On the right side of the QFD, the cells of stakeholder characteristics, where those characteristics are affected by the system parameters across the top of the matrix are assigned weight. At the bottom part of the matrix, the column is summed, which allows for the system characteristics to be weighted according to the stakeholder characteristic. In the end part, we get to know all the unit dimensions of the engineering characteristics which we need to improve with importance ratings showing which product characteristics need to be improved the most with maximum effect.

### Generate product concepts

Morphological chart<sup>11</sup> is a design tool that is used in situations where the design space is open with many possibilities and when the designer wishes to use a methodical process to generate concepts to explore this space. In a morphological chart, all the important product functions which are necessary for product development are visualized and alternative means and combinations of achieving that functionality are plotted in the chart. For all the respective product functions, there could be many possible solutions. A morphological chart is a structured approach through which we can consider an alternate solution for a designated function. These functions had to be pre-determined through previous research. If a morphological chart is used properly, it gives a user-driven approach to the generation of potential solutions.

### Concept selection

To comparing design ideas against your design criteria early in the design process, a simple design tool known as Pugh’s concept selection or Pugh’s chart is used<sup>12</sup>. This method of concept selection was designed by Stuart Pugh a British product designer in 1996. In Pugh’s chart, the left side is used for design criteria which we got using previous design methods and on the top row, we put the concepts which were designed earlier. The next step is to take one concept as a datum, this works as a reference point form with each of the design criteria is rated. The datum should be a somewhat average design concept (not the best or worst). We use a scale-like -, 0, + symbols to rate each design criteria of all the concepts against the datum concept. If any concept is superior the datum concept in respected design criteria then it is marked +, similarly, if the concept is inferior then the datum concept in respected design criteria, it is marked -. 0 is marked when we think or feel that the design criteria are very comparable to the datum concept. Once all the concepts are rated, we take a sum of all the +, 0, -, the design with the highest net rating is not necessarily the best concept but, if the ratings go against our intuition, we reexamine your ratings. The purpose of the Pugh chart is to get us a logical and systematic assessment of the pros and cons of each concept relative to our design criteria.

### Detail design

Detailed design is sometimes referred to as Embodiment design. This is a very crucial stage in the product development stage as all the smallest details in designing the concept are considered here from the material used to all the tolerances and the manufacturing methods employed. Mostly all the products manufactured are in one way or another has human interaction. Human anthropometry varies from one person to another therefore to make a design that fits most of the people well; we use Indian anthropometric data which helps us make the product even more humane. In our case, the cart is a non-motorized mode of transportation which is propelled by human force because of which ergonomics play an important role in detailed design. To convert our detailed input of dimensions and joineries we made a 3D cad which helped us to visualize the real shape of the cart. After making the 3D cad and getting satisfactory results, we can move forward to the next stage which is prototyping.

**Prototype**

Prototyping is the final stage in the Product development process. In this stage, all the design inputs given through all the stages are brought to life. In this stage first, a scale model was made to check the dynamics of the cart to understand any fault which might have skipped during the designing process. When we were satisfied with the scale model, we moved towards final prototyping which was made with the final material using final production techniques.

**Test**

The final testing and comparison were very important in proving that the new hand cart design is superior to the existing hand cart design. Due to the lack of time and the current pandemic, there were only a few tests conducted, to prove this claim we did some initial interviews with the cart pullers and conducted REBA (Rapid Entire Body Assessment) [13].

**Results**

The results of the methodology used are as follows:

**Identify customer needs**

With the help of interviews<sup>9</sup>, we concluded a set of user requirements which needs to be addressed to reduce the WMSD and increase the efficiency are as follows:

- i. Easy handling
- ii. Maneuverability
- iii. Stopping or breaking
- iv. Extra man force
- v. Balance
- vi. Parking
- vii. Theft protection
- viii. Cost

**Set target specifications**

With the help of QFD<sup>10</sup> see Table 1, we have Hierarchical list in which we must address the user needs.

- i. The design of the new cart has to be ergonomic
- ii. There must a braking system in the cart
- iii. The cart can have some kind of mechanical or electric propulsion system to get rid of extra man force required to pull the heavy load.
- iv. Maneuverability can be improved through some steering mechanism.
- v. Modular design can help with the parking and theft problem.
- vi. And finally, the cost of the cart must not go high.

Table 1— Quality Function Deployment (QFD).

strong +ve ●								
+ve ○								
-ve x								
strong -ve #								
Strong = 9								
Moderate = 3								
Weak = 1								
	Ergonomic design	Breaking	Mech/Electric assistance	Steering mechanism	Modular design	Alarm	Cost of material	
Easy handling	9	3	3	3				5 2 5 2.5 1.5 18.8 0.241
Maneuverability	9			9				5 4 5 1.3 1.5 9.8 0.126
Stopping		9						5 3 5 1.7 1.5 12.8 0.164
Extra man force			9					5 3 5 1.7 1.3 11 0.141
Balance	9							4 3 4 1.3 1.3 6.8 0.087
Parking				9				4 3 5 1.7 1 6.8 0.087
Theft protection					9			4 3 4 1.3 1.3 6.8 0.087
Cost								5 5 5 1 1 5 0.064
Abs. importance	4.086	2.199	1.992	1.857	0.783	0.783	0.576	12.28
Rel. importance	0.33	0.18	0.16	0.15	0.06	0.06	0.04	77.8 total 1
Carts now in market	1	1	1	3	4	1	2	
Direction of movement	↑	↑	↑	↑	—	—	↑	
Units	mm	feet	nlm	degree	mm	—	Rs	

Table 2 — Morphological chart.

No. of features	1	2	3	4	5
Ergonomic design					
Breaking	Disk break	Pressure brakes	Cycle Calipers	Human force	—
Mech./ elec. help	Motor & battery	Small engine	Flywheel momentum	Spring powered	Pedal
Steering mechanism	Link mechanism	Through body movement	Through a couple	Single front wheel	—
Parking	Modular design	Stack able	Modular design	—	—
Theft protection	GPS	Mechanical locking	Nut bolt	Chain points	—

**Generate product concepts**

As the morphological chart had been plotted see Table 2<sup>11</sup> using specifications form QFD<sup>10</sup> we get the results as follows.

*Features of concept 1:* Over the shoulder support beam, elongated arms, padded shoulder support, eliminates the need for lifting and pulling, see Fig. 3.

*Features of concept 2:* Electric motor assisted cart, steerable handle via rack and pinion, eliminates the need for lifting and pulling, see Fig. 3.

*Features of concept 3:* ergonomic front end, steering through a single bolt, ease of manufacturing motor and breaking can be provided, eliminates the need for lifting and pulling, see Fig. 3.

*Features of concept 4:* harness worn by user can be attached to the cart; in hand breaking can be

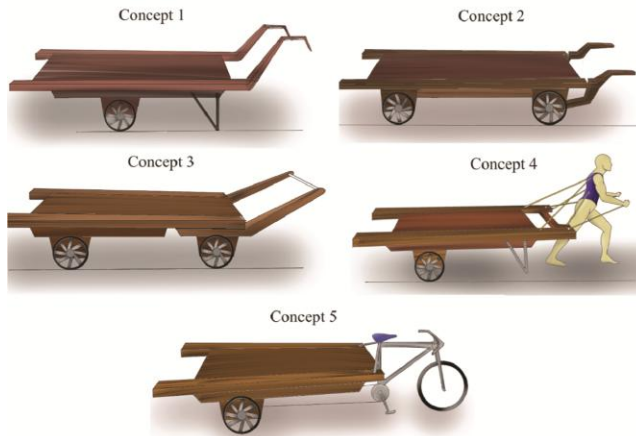

Fig. 3 — Concepts.

Table 3 — Pugh’s concept section method.

Selection criteria	Concepts				
	1	2	3	4	5
Ease of Use	-	D	0	-	0
Maneuverability	-	A	+	-	+
Breaking	0	T	0	0	0
Serviceability	+	U	+	+	+
Accessorization	0	M	0	0	0
Theft proof	0	0	+	0	0
Balance	-	0	+	-	0
Max load (Bearing)	-	0	0	-	-
Cost	+	0	0	+	0
Sum +ve	+2	0	+4	+2	+2
Sum -ve	-4	0	0	-4	-1
Sum 0	3	0	5	3	6
Total	-2	0	+4	-2	+1
Rank	4th	3rd	1st	4th	2nd

provided, eliminates the need for lifting and pulling, see Fig. 3.

**Features of concept 5:** a cycle front end providing source of propulsion and breaking, eliminates the need for lifting and pulling, see Fig. 3.

**Concept selection**

With the help of Pugh’s concept selection method see Table 3<sup>12</sup>, we concluded that Concept 3 is the best design to be taken forward. It was closely followed by concept 2 which didn’t win because the technical difficulty of manufacturing and a more prominent need of accessorization (combination of battery and motor, breaking, load sensors to assess the load on the cart, etc.) see Fig. 4.

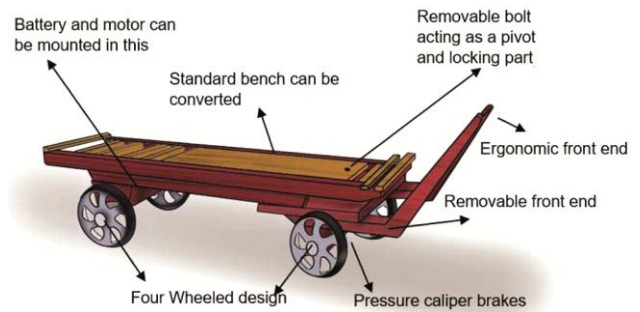

Fig. 4 — Selected concept 3 with features.

**Detail Design**

Using original cart as the base for the new design see table 4. With the help of Indian Anthropometric data<sup>14</sup>, we designed the front-end using CAD.

**Anthropometric assessment of the front end of the cart**

The front part of our cart is modular and because of that, this is where we have to add all the ergonomics so that the pushing operation of the cart becomes easier and need of lifting and pulling the cart is eliminated. All the anthropometric data of Indian males were taken from the book of Indian anthropometric dimensions for ergonomic design practice by Debkumar Chakrabarti<sup>14</sup>. To further make our design more suitable for road conditions and to fit all the men of different stature we optimized our data. The touchpoints have been taken are equated with Indian anthropometric dimensions see Fig. 5.

*The length of the handle = Span akimbo*, which is the maximum horizontal distance between the tip of elbows when both the upper arms are stretched outwards perpendicular to the trunk<sup>14</sup>.

Taking max of max value<sup>14</sup>, we get 959 mm. 959 mm is on the widest length possible, to maintain the slim profile of the cart we had taken 150 mm from the overall length of 959mm so the optimized length of the handlebar is 809 mm

*The thickness of handle = Grip inside diameter, maximum*, is measured by the tips of the thumb and middle finger remain touched to each other<sup>14</sup>.

Taking max of max value<sup>14</sup>, we get 56 mm. 56 mm is on the thickest diameter possible for a hand to fully encircle, to make the handle easier to push and reduce line load on the hand of cart puller we added 7mm to the overall diameter giving us final dimension at 63mm

*Height of handle from ground = Elbow*, most proximal point of the olecranon-tip of the ulna<sup>14</sup>

Table 4 — part, material, dimension chart.

Part or area of measurement	Material	Dimensions
Height of the cart from the ground, with respect to the main beam(A)	-	482.6mm
Height of the cart from the ground, with respect to the secondary support beam (B)	-	393.7mm
Wheel (C)	Cast Iron	431.8 mm
Length secondary support beam (D)	Malaysian Sal wood	1820 mm
Length Main support beam (E)	Malaysian Sal wood	2780 mm
Width of the main support beam and secondary support beam (F)	-	63.5 mm
height of main support beam and secondary support beam (H, G)	-	88.9 mm
Width from the back (I)	Sangwan wood	647.7 mm
Width from Front (J)	Malaysian Sal wood	520.7 mm
Width from the middle (K)	Sangwan wood	596.9 mm
Full length of the cart (L)		2895.6 mm
Secondary beam clearance length From front and back(M)		508 mm

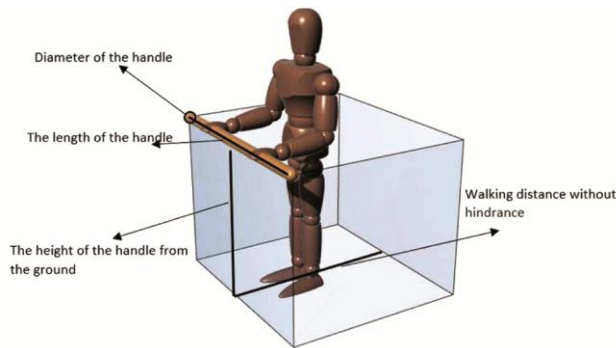

Fig. 5 — Main touchpoints for ergonomic front end.

The cart handle should be placed so that the shortest of the person should be able to push the cart. To make this cart widely used by all the cart pullers, the cart handle must come in the power zone of the puller, therefore, minimum of minimum value has been taken (male value because all cart pullers are male) while considering the principle of access which is 945mm<sup>14</sup>. To make the cart accessible by higher percentile people we have added some extra height of 165 mm and clearance for shoe 40mm so the final handle height comes out to be 1150 mm

*Space required to walk inside the front part* = *stature*, top of the head in erect stretched posture.

To define the space required between the handle and the cart body we have to take the maximum of maximum value i.e. 95<sup>th</sup> percentile male which is 1781 mm<sup>14</sup>. Now according the article<sup>15</sup> the mean step length of a male with a stature 1770mm is 795mm. To make the front part of the cart roomier to walk we can give twice step length space i.e. 795\*2 = 1590 mm. if we take 1590 mm from the cart to the handle then the shaft connecting the handle to the front part would

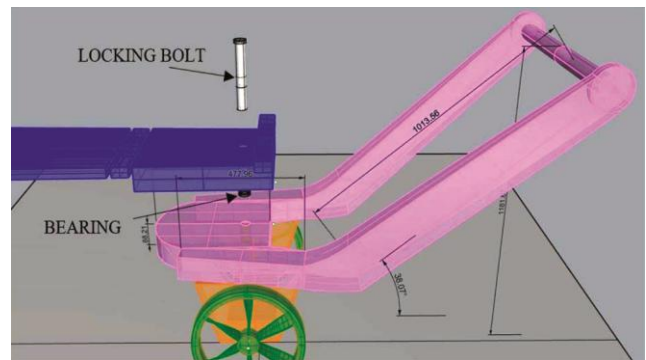

Fig. 6 — Assembly of the front part with the existing cart.

become too long and to for a smaller man 159 0mm space is on the larger side, therefore, we reduce the dimension by almost 500 mm which gives the final dimension of 1090 mm.

**CAD**

Keeping new found dimensions of touch points as the base dimensions of the front part and taking the dimensions of the existing cart we developed 3D cad see Figs. 6, 7 using Rhino 6 design to be used in renderings and manufacturing of the final prototype see Fig. 8.

**Prototype**

The final prototype was made in Old Delhi with the help of one of the few original cart manufacturers left in. The cart was made using the same material used for making the carts and there were no corners cut in making the cart. See Table 3, Fig. 9.

**Test**

After the manufacturing of the cart we did interview and conducted REBA to validate our design. Result of the tests is as follow:

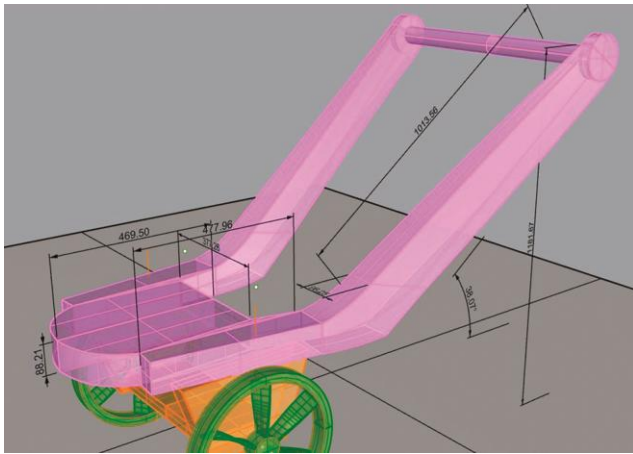

Fig. 7 — Perspective view of the front part of the cart with dimensions cart.



Fig. 8— 3D final render.



Fig. 9 — Final Prototype (New hand cart).

#### Result of interview

- i. The pushing of the cart is relatively easy.
- ii. The action of lifting and pulling has been eliminated in the new cart.
- iii. The four-wheel design makes cart stable which makes it topple proof.
- iv. The cart pullers understood the function of how to disassemble the cart without much guidance.
- v. According to the cart pullers pulling the new cart was much more comfortable than the existing cart.
- vi. They were willing to convert their old cart into the new one.



Fig. 10 — REBA Analysis.

- vii. The cart is very hard to operate when unassembled making it very difficult to steal.

#### Result of postural analysis

The rapid entire body assessment test<sup>13</sup> was done to assess the working posture of the cart puller. The results we got gave use the REBA score of 2 which means the end-user is at low risk. The old REBA score was 12 which meant that the cart pullers were are at very high risk. Now with our new REBA score of 2, we can confidently say that pushing the new cart is less likely to result Work-related musculoskeletal disorders, see Fig. 10.

#### Discussion

- i. The carts are the integral part of freight movement in Delhi, Mumbai, and many other parts of India including many railway stations.
- ii. The new cart design will reduce the chances of work-related Musculoskeletal disorders.
- iii. The pre-existing carts can be converted into the new cart design with minimal investment.
- iv. The front end of the cart has been designed using relevant Indian anthropometric data so it will accommodate the maximum Indian hand cart puller's body dimensions.

- v. The cart design uses simple assembly to connect the front end of the cart with the main cart using a simple 22inch bolt and a thrust bearing between the joint to provide steerability and provides protection from theft as it can be unassembled.
- vi. As per the requirement of the cart puller, a battery and motor combination can be fitted in the cart to help with the extra assistance which was earlier given by people pushing from behind see fig. 2.
- vii. This type of cart will also be beneficial for big industries which transport their goods within their premises.
- viii. Braking mechanism can be provided which will be beneficial for the road with uphill or slope.
- ix. The maintenance and manufacturing of the cart is fairly simple as the material used is locally sourced and which are inexpensive and easy to assemble.

### Conclusions

From our study of design development and testing we can say that the new cart design is more ergonomic, has more load-bearing capacity, steering capabilities, theft-prone, can be equipped with battery motor combination and braking as future need be, reduces chances of WMSD i.e., Work-related Musculoskeletal disorders that are injuries or disorders of the muscles, nerves, tendons, joints, cartilage, and spinal discs. All the material used in the manufacturing of the cart is locally sourced which makes the cart economical to

manufacture, service, or repair which also makes this cart entirely made in India.

### References

- 1 Patel T & Karmakar S, Introduction to Ergonomics Introduction to ergonomics, R S Bridger, Taylor & Francis/CRC Press, Boca Raton, London, New York (2008).
- 2 McCormick E J & Sanders M S, *Human factors in engineering and design*, McGraw-Hill Companies, 1982.
- 3 Lay M G & Volti R, *Technology Culture*, 35 (1994) 608.
- 4 Ruesh M & Glücker C, Urban logistics in Europe: some statistical elements and experiences of regulation in European cities, 2002.
- 5 The Republic of Uganda, 2012, Uganda Draft Non- Motorized Transport Policy, Ministry of Works and Transport, Uganda.
- 6 Tom Ritchey, coffee bike Retrieved from- <http://projectrwanda.org/coffeebike.php> Accessed on 9 December, 2019.
- 7 Ravichandran N, World class logistics operations, The case of Bombay dabbawallahs, 2005.
- 8 Gupta S, *Transport Res Proc*, 25 (2017) 978.
- 9 Young M S & Stanton N A, Applying interviews to usability assessment, Handbook of human factors and ergonomics methods, (2005) 29.
- 10 Akao Y & King B, Quality function deployment: integrating customer requirements into product design Cambridge, MA: Productivity press, 221 (1990).
- 11 Roozenburg N F & Eekels J, Product design: fundamentals and methods, 1995.
- 12 Pugh S & Clausing D, Creating innovative products using total design: the living legacy of Stuart Pugh, Addison-Wesley Longman Publishing Co, Inc 1996.
- 13 Hignett S & McAtamney L, *Appl Ergon*, 31 (2000) 201.
- 14 Chakrabarti D, *Indian anthropometric dimensions for ergonomic design practice*, National institute of design, 1997.
- 15 Zhang Y, Li Y, Peng C, Mou D, Li M & Wang W, *Sensors*, 18 (2018) 1039.