1
by 1 1

Submission date: 06-Jan-2019 04:53PM (UTC+0700)

Submission ID: 1061680215

File name: 01_Jurnal_Ilmiyah_International.pdf (327.57K)

Word count: 1984

Character count: 10213

A prototype fire detection implemented using the Internet of Things and fuzzy logic

Tri Listyorini† & Robbi Rahim‡

† Universitas Muria Kudus, Kudus, Indonesia
‡ Universiti Malaysia Perlis, Kubang Gajah, Malaysia

ABSTRACT: Dangerous fires often occur because slow fire spots have the potential to become big fires that are difficult to extinguish. An example of this danger are peatlands in Riau, Indonesia. These dangerous conditions can be ameliorated by first detecting them. A device was developed that can detect fire spots by using the Internet of Things (IoT) and fuzzy logic. This early prototype detection tool could identify hotspots in the peatlands by using fire sensors, temperature sensors, servo motors, buzzers and surveillance cameras controlled by a WEMOS ESP8266 microcontroller and by applying the fuzzy logic method to analyse the intensity of the detected flames. Based on an experiment using the prototype, fire detection devices with an IoT connection can speed up the monitoring of fire hotspots, and the use of fuzzy logic can minimise false warnings from fire detection devices. The prototype could be used as a medium of learning for high school students majoring in computer engineering and networking.

INTRODUCTION

The Internet of Things (IoT) involves continuously connected Internet devices that can be used to simplify activities in many aspects of life [1][2]. For example, the IoT could be used for peatland surveillance in countries, such as Indonesia that have vast peatlands.

Detection of fire hotspots could be done by an IoT connected device, which would allow quick and early detection. However, the detection of fire hotspots on peatlands is error prone, especially concerning the level of heat detected by fire sensors. The use of fuzzy logic for the detection of fire hotspots can minimise detection errors, which arise because of variations of the heat intensity of fires [3-5]. Fuzzy logic can be used to model this variability and; hence, minimise detection errors [6].

The implementation of an IoT-based detection monitor using fuzzy logic for the detection of fire hotspots on peatlands would allow improved, real-time Internet-connected monitoring. A fire detection prototype could be used as a medium of learning for high school students majoring in computer engineering and networking. It could show how the Internet works and also how to obtain data from a tool linked into the IoT.

METHODOLOGY

The IoT allows the connection of machines, equipment and sensors to obtain data to manage their performance, enabling devices to collaborate and even act independently on newly acquired information [2][7]. Thus, the IoT connects machine to machine, so that the devices can interact and work independently. The goal is to make human interaction with objects more efficient, and for objects to communicate with other objects [1][2][7].

The Internet of Things is a technological revolution that represents the future of computing and communications, and its development depends on technical innovation in critical areas, ranging from wireless and sensors to nanotechnology [1]. The research reported in this article involved the development of an IoT connected fuzzy logic fire detection prototype to monitor and detect hotspots in peatlands.

Fuzzy Logic

A fuzzy set used in fuzzy logic has a membership for a set object in the range of 0 to 1 e.g. 0.7; which means the object can be part in and part out of the set [8]. A conventional or *crisp* set only allows an object to be *in*, i.e. 1, or *out*, i.e. 0. In logic terms 1 corresponds to true and 0 to false. A conventional control system will categorise a value as true or false, i.e. 1 or 0; values either will be rounded up and treated as true (1) or ignored and treated as false (0). Fuzzy logic can

deal with values in the range of 0 to 1. The fuzzy logic output is not only a value of 1 or 0, but can be an intermediate value used to control processes in the control system [8].

A fire sensor would activate an alarm based on temperature using a straightforward fuzzy function to define the temperature boundaries and the corresponding decisions [9][10]. The fuzzy process for decision-making is used to decide, if the temperature of the fire is low or normal, medium or high. If the temperature is low, then, the early fire detector alarm is inactive since this is normal; if the fire temperature is medium or high, the early fire detector alarm is active and information is sent to the supervisor, so that the fire can be extinguished.

Table 1: Conditions determined by the temperature sensor.

No	Temperature (°C)	Condition
1	25° C	Low
2	28° C	Low
3	30° C	Low
4	31° C	Medium
5	32° C	Medium
6	35° C	Medium
7	36° C	High
8	38° C	High
9	39° C	High
10	40° C	High

Table 1 is a sensor condition determination corresponding to the temperature level of the early fire detector. A high-temperature level (30 to 40 degrees Celsius) will trigger the buzzer alarm.

Prototype Fire Detector

An early detector of hotspots has a function to detect the presence of fire spots. The tool detects the presence of hotspots on peatlands before a fire becomes significant. Components used to make a prototype detector of hotspots in peatlands included:

1. Microcontroller WEMOS ESP8266

The controller used in the prototype fire detection system was the WEMOS ESP 8266, which is an Arduino Uno clone board equipped with an ESP8266 Wi-Fi module. This board has 11 digital input/output pins, an analog input pin (maximum input 3.2 V), a micro USB connection and a power jack with 9-24 V input [11][12].

2. Temperature sensor LM35

The LM35 temperature sensor is an very accurate exact temperature measuring device with linear output voltage for a temperature range from -55° C to 150° C [13].

3. Fire sensor

Fire sensors detect fire as a light source with wavelength in the range of 760 nm to 1,100 nm.

4. Servo motor

The servo motor has a closed feedback system for the position of the engine back to the control circuit in the servo motor.

5. Buzzer

A buzzer is an electronic component that converts electrical vibrations into sound.

6. Tripod

Tripod is a tool used to reduce the noise caused by shocks and also used as a prototype tower.

Figure 1 is a detailed diagram for each element in the connected system.

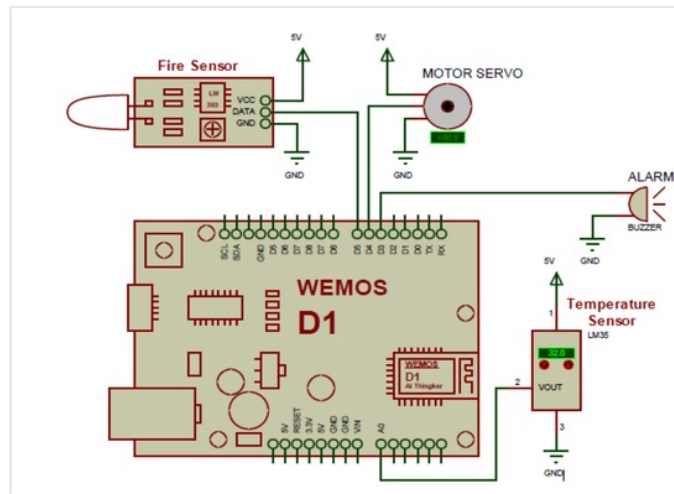
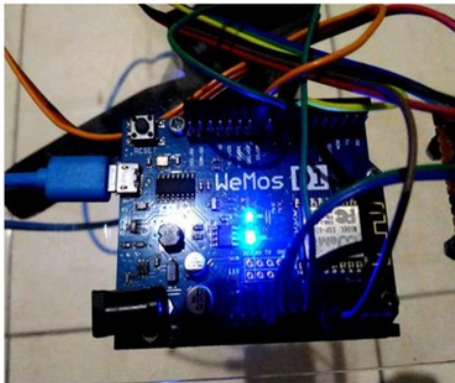

Figure 1: A prototype circuit for an early fire detection device.

RESULTS AND DISCUSSION

The fire detection experimental equipment consisted of a WEMOS ESP8266 microcontroller, temperature sensor (LM35), flame detector, servo direction and alarm warning. The microcontroller sends data to the cloud server, and an Android application retrieves the data from the cloud server. Figure 2 photographs show the experimental equipment being tested.



a)

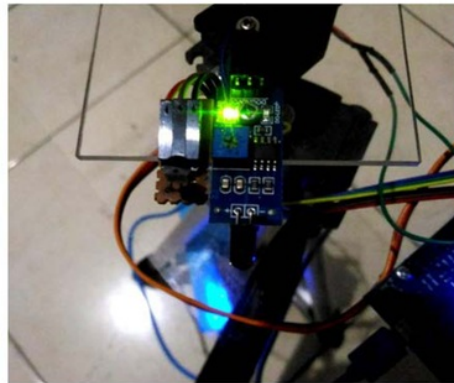

b)

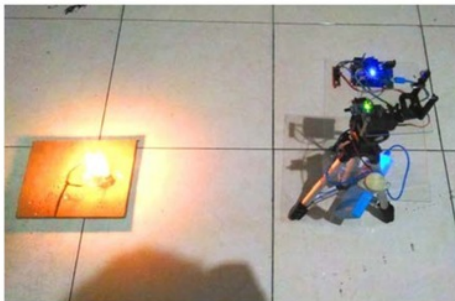

c)



d)

Figure 2: Experiments using the prototype device. As shown in photographs above: a) testing the WEMOS ESP8266 microcontroller; b) the fire sensor test; c) testing that the sensor detects fire hotspots; and d) testing the servo motor in the direction of the fire point located in the northeast direction.

The fire detection test as shown in Figure 2 used the fuzzy temperature values in Table 1. As an example, here is the fuzzy membership determination for the low or normal category:

$$\mu(x, a, b) = \begin{cases} 0; & x \leq a \\ \frac{x - a}{b - a}; & a \leq x \leq b \\ 1; & x \geq b \end{cases}$$

$$\mu_{\text{NORMAL}}[26^{\circ}\text{C}] =$$

$$\begin{cases} 0, & x \leq 25 \\ \frac{26 - 25}{30 - 25}, & 25 < x < 30 \\ 1, & x \geq 30 \end{cases}$$

$$= \frac{1}{5} = 0.2$$

$$\mu_{\text{NORMAL}}[27^{\circ}\text{C}] =$$

$$\begin{cases} 0, & x \leq 25 \\ \frac{27 - 25}{30 - 25}, & 25 < x < 30 \\ 1, & x \geq 30 \end{cases}$$

$$= \frac{2}{5} = 0.4$$

$$\mu_{\text{NORMAL}}[28^{\circ}\text{C}] =$$

$$\begin{cases} 0, & x \leq 25 \\ \frac{28 - 25}{30 - 25}, & 25 < x < 30 \\ 1, & x \geq 30 \end{cases}$$

$$= \frac{3}{5} = 0.6$$

$$\mu_{\text{NORMAL}}[29^{\circ}\text{C}] =$$

$$\begin{cases} 0, & x \leq 25 \\ \frac{29 - 25}{30 - 25}, & 25 < x < 30 \\ 1, & x \geq 30 \end{cases}$$

$$= \frac{4}{5} = 0.8$$

$$\mu_{\text{NORMAL}}[30^{\circ}\text{C}] =$$

$$\begin{cases} 0, & x \leq 25 \\ \frac{30 - 25}{30 - 25}, & 25 < x < 30 \\ 1, & x \geq 30 \end{cases}$$

$$= \frac{5}{5} = 1.0$$

There are similar membership functions for the medium and high fire conditions. Using these membership values, possible false alarms can be decreased.

Based on the temperature membership values in Table 1, an experiment with various types of fire source was performed using the fire detection prototype. In Table 2 observations of the fire sensors are displayed against different types of fire source.

Table 2: Fire detection observations.

No.	Source	Length (cm)	Fire sensor (Candela)	Detection results
1	Cigarettes	10	450 Cd	Not detected (normal)
2	Lighter	10	480 Cd	Not detected (normal)
3	Matches	20	500 Cd	Not detected (normal)
4	Candle	25	650 Cd	Detected (medium)
5	Paper burning	30	680 Cd	Detected (medium)
6	Fire gas stove	35	700 Cd	Detected (medium)
7	Torch	40	900 Cd	Detected (high)
8	Dry grass	50	880 Cd	Detected (high)
9	Great fire	55	900 Cd	Detected (high)
10	Great fire	60	950 Cd	Detected (high)

Shown in Table 2 are the results of tests conducted on various types of fire source based on temperature and fire intensity with a maximum distance of 60 cm. Valid detection results were obtained and false alarms were avoided.

CONCLUSIONS

A fire point detection prototype was implemented by applying the IoT and fuzzy logic. The IoT was used to send data from fire sensors in the form of temperature and alarms to the cloud server, which were downloaded by applications running on an Android platform.

The fire detection prototype used a simple temperature sensor with a range of 100 cm; this could be replaced with other heat sensors with a greater range. Such fire detection devices could be located in peatland sites. The use of fuzzy logic to determine the temperature condition of the fire minimises errors in the alarm notification. The use of the Tsukamoto method, Sugeno, Mamdani or adaptive neuro-fuzzy inference system (ANFIS) could be used as an additional method in the temperature detection process [5][6].

The use of technology in education is important in the digital era. The prototype discussed here could be tested by students directly and even further improvised. The impact on engineering and technology education arises from the practice and not just theory that students receive. Hence, the peatland fire detection prototype could enable students to learn engineering concepts and the IoT as applied to everyday life.

REFERENCES

1. Qian, H. and Wang, Y.-J., IoT technology and application. *Tien Tzu Hsueh Pao/Acta Electron. Sin.*, 40, 5, 1023-1029 (2012).
2. Liu, T. and Lu, D., The application and development of IOT. *Proc. 2012 Inter. Symp. on Infor. Technologies in Medicine and Educ.*, ITME, 2, 991-994 (2012).
3. Perangin-angin, M.I., Khairul, and Siahaan, A.P.U., Fuzzy logic concept in technology, society, and economy areas in predicting smart city fuzzy logic concept in technology, society, and economy areas. *Inter. J. of Recent Trends in Engng. Research*, 2, 12, 176-181 (2016).
4. Khair, U., Fahmi, H., Al Hakim, S. and Rahim, R., Forecasting error calculation with mean absolute deviation and an absolute percentage error. *J. of Phys. Conf. Ser.*, 930, 1, 12002 (2017).
5. Singhala, P., Shah, D.N. and Patel, B., Temperature control using fuzzy logic. *Inter. J. of Instrum. Control Syst.*, 4, 1-10 (2014).
6. Harliana, P. and Rahim, R., Comparative analysis of membership function on Mamdani fuzzy inference system for decision making. *J. of Phys. Conf. Ser.*, 930, 1, 12029 (2017).
7. Farooq, M.U. and Waseem, M., A review on Internet of Things (IoT). *Inter. J. of Comput. Appl.*, 113, 1, 1-7 (2015).
8. Sivanandam, S.N., Sumathi, S. and Deepa, S.N., *Introduction to Fuzzy Logic Using MATLAB* (2007).
9. Siregar, D., Arisandi, D., Usman, A., Irwan, D. and Rahim, R., Research of simple multi-attribute rating technique for decision support. *J. of Phys. Conf. Ser.*, 930, 1, 12015 (2017).
10. Risawandi, R. and Rahim, R., Study of the simple multi-attribute rating technique for decision support. *Inter. J. of Scientific Research in Science and Technol.*, 2, 6, 491-494 (2016).
11. Robot-r-us, WeMos D1 R2 WiFi ESP8266 Board Compatible with Arduino IDE (2018), 18 October 2017, <https://www.robot-r-us.com/wireless-wifi/wemos-d1-r2-wifi-esp8266-development-board-compatible-with-arduino.html>
12. Haryanto, T., Belajar IoT - Menyalakan dan Mematikan Lampu Via Internet Menggunakan AgnosThings dan ESP8266 (2016) (in Indonesian), 20 October 2017, <https://www.codepolitan.com/tutorial/belajar-iot-menyalakan-mematikan-lampu-via-internet-menggunakan-agnosthings-dan-wemos-esp8266> (in Indonesian).
13. Learning about Electronics. How to Build a LM35 Temperature Sensor Circuit. 13 September 2017, <http://www.learningaboutelectronics.com/Articles/LM35-temperature-sensor-circuit.php>

ORIGINALITY REPORT

20%

SIMILARITY INDEX

11%

INTERNET SOURCES

18%

PUBLICATIONS

11%

STUDENT PAPERS

PRIMARY SOURCES

-
- | | | |
|----------|--|-----------|
| 1 | R Ratnadewi, H Nurdiyanto, A Najmurrokhman, C Prabowo et al. "Control and Notification Automatic Water Pump with Arduino and SMS Gateway", IOP Conference Series: Materials Science and Engineering, 2018
Publication | 4% |
| 2 | china.iopscience.iop.org
Internet Source | 3% |
| 3 | Jutika Borah, Kandarpa Kumar Sarma, Pulak Jyoti Gohain. "chapter 8 Learning-Aided IoT Set-Up for Home Surveillance Applications", IGI Global, 2019
Publication | 2% |
| 4 | pastebin.com
Internet Source | 1% |
| 5 | Martha Kafuko, Tom Wanyama. "Chapter 10 A Multi-agent System for Supervisory Temperature Control Using Fuzzy Logic and Open Platform Communication Data Access", Springer Nature, 2019 | 1% |

6

A Chairunnas, I Abdurrasyid. "Near field communication (NFC) model for arduino uno based security systems office system", IOP Conference Series: Materials Science and Engineering, 2018

Publication

7

Bokolo Anthony Jnr, Mazlina Abdul Majid, Awanis Romli. "A Trivial Approach for Achieving Smart City: A Way Forward towards a Sustainable Society", 2018 21st Saudi Computer Society National Computer Conference (NCC), 2018

Publication

8

Submitted to University of East London

Student Paper

9

Submitted to Coventry University

Student Paper

10

Submitted to Loughborough University

Student Paper

11

Liu, Jihong, and Jie Yu. "Research on the Framework of Internet of Things in Manufacturing for Aircraft Large Components Assembly Site", 2013 IEEE International Conference on Green Computing and Communications and IEEE Internet of Things

1%

1%

1%

1%

1%

1%

and IEEE Cyber Physical and Social Computing, 2013.

Publication

12

T L Grigorie. "Adaptive neuro-fuzzy controllers for an open-loop morphing wing system", Proceedings of the Institution of Mechanical Engineers Part G Journal of Aerospace Engineering, 11/01/2009

Publication

1%

13

Submitted to Royal Holloway and Bedford New College

Student Paper

1%

14

Marco Brambilla, Eric Umuhoza, Roberto Acerbis. "Model-driven development of user interfaces for IoT systems via domain-specific components and patterns", Journal of Internet Services and Applications, 2017

Publication

1%

Exclude quotes Off

Exclude matches < 5 words

Exclude bibliography Off