

Wireless control system for spy devices based dual tone multi frequency technology

Jabbar Shatti Jahlool, Mohammed Abdulla Abdulsada

Department of Computer Technique's Engineering, Dijlah University College, Iraq

Article Info

Article history:

Received Feb 16, 2020

Revised Jul 7, 2020

Accepted Jul 29, 2020

Keywords:

Acoustic communication

Arduino board

DTMF

GSM network

Remote control

Wireless control

ABSTRACT

Obtaining information is one of the most important requirements for intelligence works, spy surveillance cameras and listening devices are among the important means for this. One problem of using these means is a mechanism of controlling them to sustain their work efficiently for the perpetuating of achieving the purpose of their installation. In this research, the problem of controlling these devices has been overcome, by designing a system dependent on the dual tone multi frequency (DTMF) and global system for mobile (GSM) networks. In the proposed work, designing and implementing a system to remotely and wirelessly control of the movement of spy cameras in all directions as well as the ability to control the on/off listing audio device anytime and anywhere. The proposed mechanism is implemented by dividing the work into nine modes, with each one performing one specific function. These work modes are used to control all system activities such as control the horizontal directional motor (HDM) to change the spy camera in different horizontal directions, control the vertical directional motor (VDM) to change the camera in vertical directions and control the working status of the listening device.

This is an open access article under the [CC BY-SA](https://creativecommons.org/licenses/by-sa/4.0/) license.



Corresponding Author:

Jabbar Shatti Jahlool,
Department of Computer Technique's Engineering,
Dijlah University College,
Baghdad, Iraq.
Email: jabbar.shatti@duc.edu.iq

1. INTRODUCTION

One of the most applications and high reliable are the spy systems. Spying devices like surveillance cameras, listening devices and recording devices for picture, sound or calls. The scope of applications of these devices includes the Central Intelligence Agency, surveillance of persons, and collection of information. Such devices, in order to be more effective, it is necessary to control their activities wirelessly from remote places. A model that allows remote control of the robot was implemented via one of the most advanced communication technologies for data transmission, which is dual tone multi frequency (DTMF). This technology is more efficient and better than Wi-Fi and Bluetooth. Since at DTMF it is possible to operate and control devices from anywhere, regardless of geographical location. While this process is not possible by using Wi-Fi and Bluetooth, because it's limited to short ranges [1].

Children or elderly are monitored directly with a controlled robot. The movement directions of the robot are controlled during a phone call and through DTMF technology; it sends commands to move the robot in a controlled direction. The camera installed on the robot can send the live streaming of audio and video to the robot control center at the desired location. Arduino IDE is used as a programming software and IP WebCam application

for Android to implement the video streaming [2]. The user sends control commands over a remote phone by exploiting global system for mobile (GSM) networks and DTMF technology. Another mobile phone is used at home for the purpose of receiving the transmitted tones. With this phone and other hardware electronic components, used the transmitted commands, for control of home appliances remotely anywhere without restrictions in distance or time [3, 4]. Based on GSM networks to send short message service (SMS) and through Raspberry Pi Board, a surveillance camera system is controlled to capture video and then distribute it to systems connected to the network in addition to alerting the administrative person via SMS alarm [5].

Wireless and remote control of multi electrical appliances by using cell phone based DTMF technique, so that can turn on or off each appliance separately through the user phone numbers after making a call [6, 7]. Remote control system for angular position of stepper motor using DTMF signal, implemented by using 8051 microcontroller [8]. The using mobile controlled robots for direct current (DC) motors regulating and their domestic communication for remotely control multi home electric appliances [9]. Robot car is remotely controlled by a mobile phone using DTMF method, the motion of the car on all direction can be controlled depend on the button pressed at the user phone that generate DTMF signal this signal will pass through the multi processing to result a motion of the car [10]. Suggests method by using DTMF tone technology to design a control system depend on the tone generated when the user mobile phone pushes a keypad buttons through the call or when connected to a remote mobile phone robot [11]. Mobile phone used for control of toy car depends on the received DTMF tone is processed by the (ATmega16) microcontroller. The microcontroller receives control signals and then analyzes them based on the special algorithm assigned to this object, then issues orders to control the direction of the toy car in the required directions [12].

Suggests a remote-control technique based on mobile to control the direction of the DC motor, this is done through generate a control signal to drive the DC motor movement based a GSM modem either by SMS or DTMF techniques [13]. GSM network and mobile phones represent one of the more effective and important tools that are using for remote control of multi applications in different fields [14-16]. Important and civilized means of exchanging information is cellular communication. As a result, it has become impossible to dispense with these networks in all countries of the world. Because of that widespread, it has been relied on for technological uses such as remote control of the ON and OFF of home appliances [17-21]. Transmission of a control signals has been achieve by depending of telephone line for two sections local and remote, this is for remote control of switching applications by taking advantage of a DTMF property [22].

In this paper, a wireless remote-control system has been designed. This system has the ability to provide different operating modes. These modes divided into nine cases, so that each case performs a specific function which includes: horizontal direction control for clockwise and anticlockwise 360°, shift right 90°, shift right 180°, shift left 90°, vertical direction control has the ability to move the camera up to 30° or down to 30°, default mode that makes the camera in a steady position, whether in horizontal or vertical directions, operational control of spy listening device to ON/OFF and final mode that's control of all the spy devices to be turn ON/OFF. The technology adopted in this design is DTMF and GSM network. The required components to implemented the proposed design consists of Arduino board, two mobile phones, DTMF decoder, L293 motor driver, two SPDT (single pole double through) latch relays', ULN2003 integrated circuit, two D.C motors, power supply, spy camera and listening device.

2. SYSTEM COMPONENTS AND METHODOLOGY

The current system components as shown in the block diagram in Figure 1 can be given a brief explanation as follows: Arduino as a central processing component to implement the system algorithm. Two mobile phones are used, one of which is intended for the user to generate DTMF tones, and then these tones are sent via GSM network to a remote phone for transfer to the decoder. Use the DTMF CM8870 IC (integrated circuit) decoder that decodes the received DTMF analog tone pairs and converts them to 4 bits digital tones for ease of handling with other digital devices [23]. The decoder will recognize the tone frequency of the cell phone key and change to its equivalent digital code which is then fed to four inputs of Arduino pins (PD5, PD4, PD3, PD2). The Arduino board will process all the system functions depend on the proposed algorithm. The sketch is the name of algorithm code written. The software used for developing such sketch is known as the Integrated Development Environment (IDE) [24-26].

A set of control signals, result from reading and analysis process that occur during the implementation of the algorithm code. These signals are intended for multiple functions, namely to rotate the horizontal directional motor (HDM) and vertical directional motor (VDM) of the spy camera at the desired direction for up, down, left and right. Other control signal connected to current amplification relay driver ULN2003 to drive two SPDT latch relays', first the main ON/OFF latch relay (RL1), who controlled the prevention or passage of main supply voltages to the spy devices, second listening ON/OFF latch relay (RL2), used for control the operation of listening device for ON/OFF state. Crystal oscillator (3.597 MHz) is used for providing clock to

MT8870. For sufficient drive the two DC motors (HDM & VDM) of spy camera, a high voltage and current drivers are required, for these reasons the L293D driver which is designed to provide bidirectional drive currents of up to 600-mA at voltages ranging from 4.5 V to 36 V. This module was designed to drive DC and bipolar stepping motors, solenoids and relays [27]. Power supply unit, consist of 12 volts battery, two types of regulators 7808 and 7805. This unit is responsible for the power supply function of all system components.

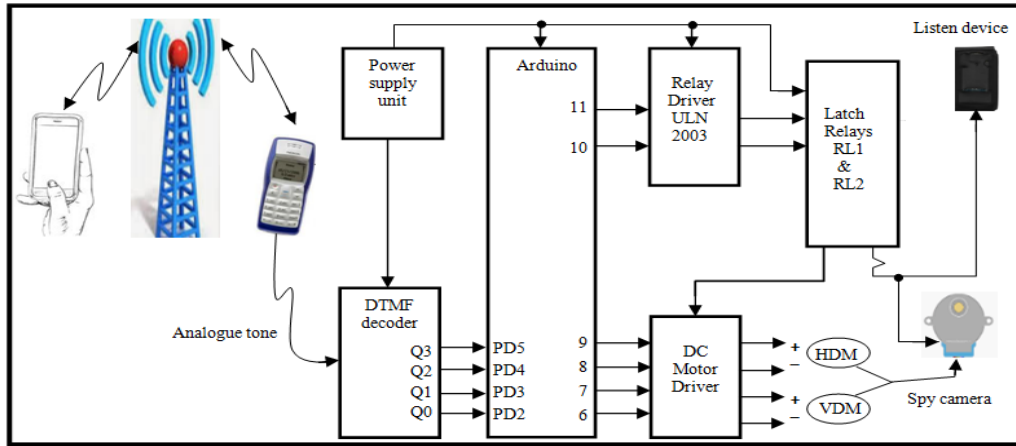

Figure 1. Proposed system block diagram

2.1. DTMF meaning

DTMF is a system used for signal tone generator. The tone that is generated when a button is pressed on the user’s mobile phone keypad through the call so that each press of a number will generates a special tone. There are 16 unique combinations tones. Twelve standard signal tones. Ten of these tones represent the numerals zero through nine. Two represent asterisk (*) and octothorp (#). And four sub- signal or special tone denoted by (A, B, C and D). Most of our mobile phones use twelve out of the sixteen possible tones [28-30]. Each tone is comprised from two frequencies, low frequency identify to row line and high frequency corresponding to column line. The all frequency used for DTMF system of each keypad are summarized in Table 1.

Red key (A, B, C, D) DTMF signal not available on a standard phone keypad. The frequency amount of each keypad button is calculated by adding the row and column frequency [31]. As example, if number (1) keypad is pressed, a frequency value equal to (1906 Hz) will produced which comes from the summing of the frequency of row and column of the pressed number i.e. (697+1209). Table 2. Explain all keypad numbers, frequencies, analogue tones and equivalent binary tones.

Table 1. DTMF keypad row and column frequencies

Low Frequency Hz	High frequency Hz			
	1209	1336	1477	1633
697	1	2	3	A
770	4	5	6	B
852	7	8	9	C
941	*	0	#	D

Table 2. DTMF process

Keypad number	Low frequency Hz	High frequency Hz	Analog tones frequency Hz	Equivalent binary tones Q3 Q2 Q1 Q0
1	697	1209	1906	0001
2	697	1336	2033	0010
3	697	1477	2174	0011
4	770	1209	1979	0100
5	770	1336	2106	0101
6	770	1477	2247	0110
7	852	1209	2061	0111
8	852	1336	2188	1000
9	852	1477	2329	1001
*	941	1209	2150	1010
0	941	1336	2277	1011
#	941	1477	2418	1100

3. PROPOSED SYSTEM FLOWCHART

The proposed system consists of two parts. Hardware and software, the software part will be implemented by Arduino sketch code depend on the flowchart shown in the Figure 2, the algorithm start by reading the four binary tones (Q3, Q2, Q1, Q0). These DTMF tones generated when the user makes a call to the remote place phone and if any key is pressed through the call. The user phone generates tones matches with the pressed key number, these tones send through GSM network to the remote place phone then relay to DTMF decoder as input analogue signals.

The decoder will output four binary digital tones denoted as (Q3, Q2, Q1, Q0). These tones connected to the four digital inputs ports of Arduino board at the pines (PD5, PD4, PD3, PD2). Depend on the reading and analyzing of these tones, and by assigning a function to each tone, the algorithm execute different of subroutines leads to generate a set of output control signals in form of logic high or low and accordingly rotates the HDM and VDM of spy camera motors, also to turn ON/OFF the listen device. In this proposed design, nine cases are uses (nine tones), for each case, there is a subroutine that is executed to generate a control signal for the purpose of fulfilling the required function. Details of all proposed cases required are shown in the system flow chart in Figure 2.

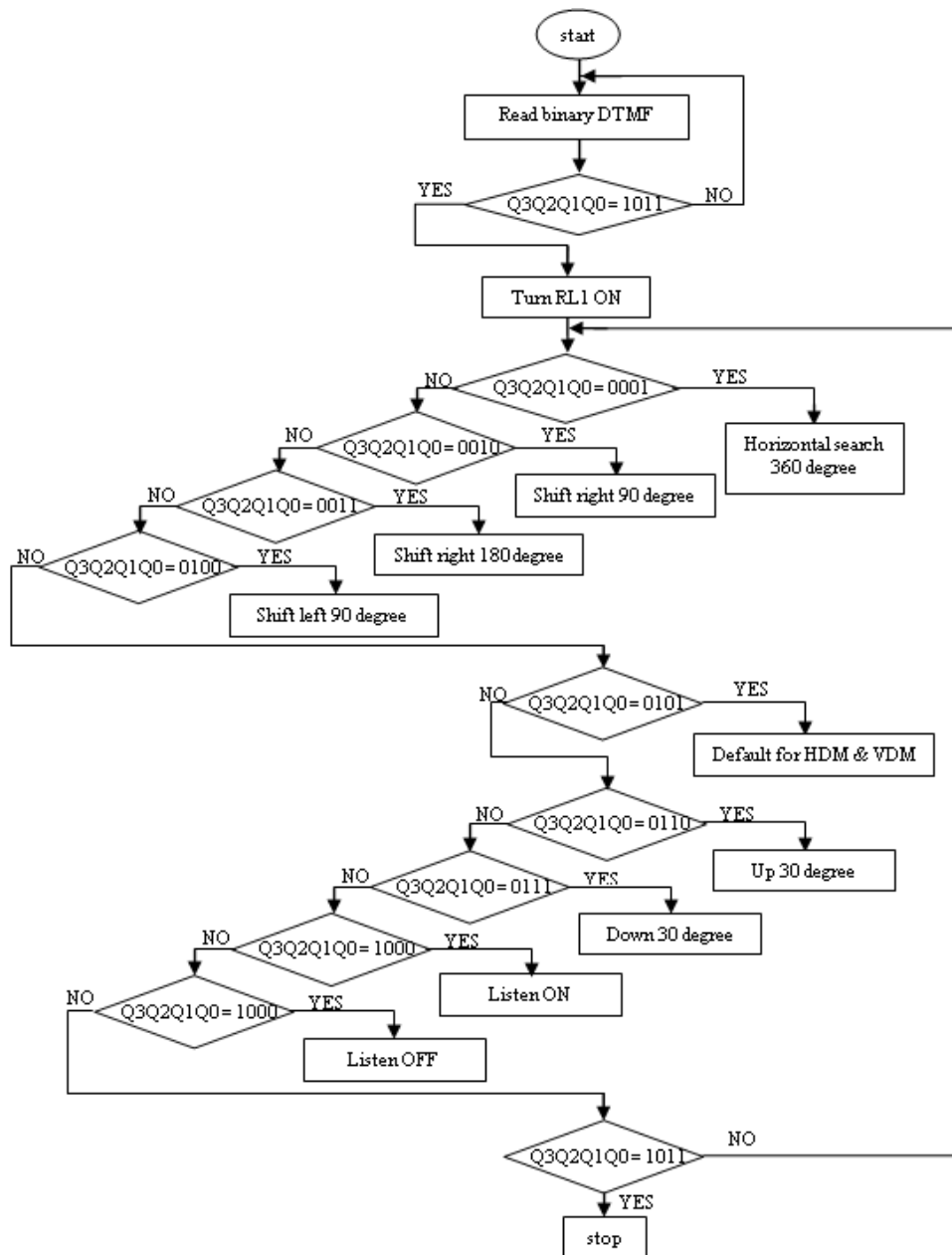

Figure 2. Proposed system flowchart

4. DETAILS SYSTEM HARDWARE DESCRIPTION

The hardware circuit component of the proposed system has shown in the Figure 3, the first unit is the power supply unit (PSU). This unit consists of battery and two regulators the function of this unit is to equip all design components with the required operational voltages. Two mobile phones are used for the purpose of generating tone signals and the local GSM networks are used for the connection between them. Important things should be taken into consideration. The keypad sounds must be activating at maximum value for the user phone, this is for purpose of guarantee of tones generation. At the remote place phone, to ensure its working properly, two points must be taken into consideration, first activating the automatic answer service, second increase the speaker volume to the highest value, this is to guarantee receiving the tones.

The user phone used to generate DTMF tones with any key pressed though call. These tones are received by remote place phone then carried over to the DTMF decoder for purpose of generating four binary tones at bits (Q3, Q2, Q1, Q0). This tone connected to Arduino board at digital ports pins (5, 4, 3, 2). The board represents the central processing component through which the algorithm is implemented to meet all the requirements of the system working. Depending on these four digital entries, the algorithm will implement multi functions (nine cases) as indicated in the flowchart. This processes leads to generate different control signals at the board pins (6 to 11), which leads to control of several activities of spy devices as explain in Table 3.

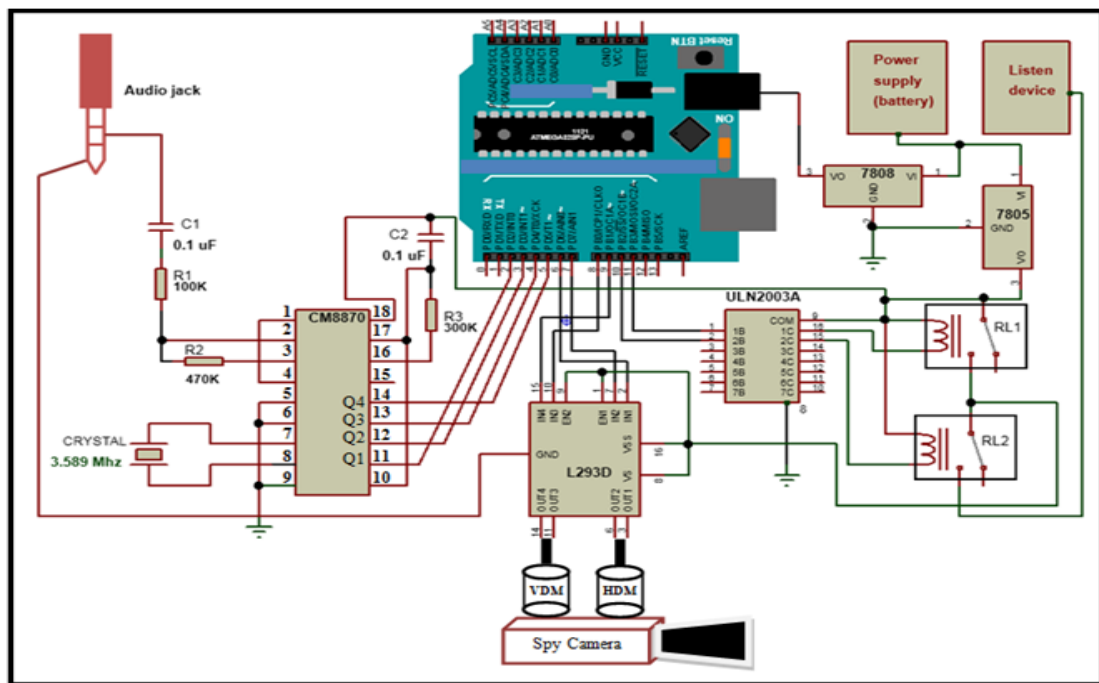

Figure 3. Hardware circuit diagram of the proposed system

Table 3. Proposed activities for the system working

Cases No.	Arduino pins	Command code	Command name	Status and function
1	6 7	HDMA SM	Horizontal direction motor at search mode	Pin 6 = Logic 1 and Pin 7 = Logic 0 clockwise direction Pin 6 = Logic 0 and Pin 7 = Logic 1 anticlockwise direction
2	6 7	HDMSR90	Horizontal direction motor shift right 90 degree	Pin 6 = Logic 1 and Pin 7 = Logic 0
3	6 7	HDMSR180	Horizontal direction motor shift right 180 degree	Pin 6 = Logic 1 and Pin 7 = Logic 0
4	6 7	HDMSL90	Horizontal direction motor shift left 90 degree	Pin 6 = Logic 0 and Pin 7 = Logic 1
5	6 7	DHAVDM	Default horizontal and vertical direction motors	Pin 6 = Logic 0 and Pin 7 = Logic 0 default case for horizontal Pin 8 = Logic 0 and Pin 9 = Logic 0 default case for vertical
6	8 9	VDMU30	Vertical direction motor up 30 degree	Pin 8 = Logic 1 and Pin 9 = Logic 0 shift up 30 degree
7	8 9	VDMD30	Vertical direction motor down 30 degree	Pin 8 = Logic 0 and Pin 9 = Logic 1 shift down 30 degree
8	10	LDONOFF	Listening device ON or OFF	First Pin 10 = Logic 1 listening device at ON state Second listen device OFF
9	11	ADONOFF	All devices at ON or OFF	First Pin 11 = Logic 1 Devices ON second devices OFF

The activities implemented by the proposed system can be divided into nine cases or modes. Details function of each case is shown as follows:

4.1. Case one: horizontal search mode

A 360° horizontal search is performed in this case which enables the HDM of spy camera will continuous rotate 360° clockwise or counterclockwise with a constant speed, so that the 360° will covered at approximately period of time equal to one minute and may be change to (0.5 or 2) minutes. This case done when the user pressed the key number 1, which lead to output binary tone equal to (Q3Q2Q1Q0=0001). If the system algorithm read this value, the command name HDMASM will executed, result to generate a pair of control signals at pins (6 and 7) which leads to rotate the HDM in two ways. The first way, the clockwise search that is occurs when the state of pin (6) at logic one and pin (7) at logic zero. The second way, the anticlockwise search, occur when pin (6) at logic zero and pin (7) at logic one.

4.2. Case two: 90° shift right

Press key number 2 at activate this case. Binary tone reading equal to (Q3Q2Q1Q0 = 0010) will generated and result to execute HDMSR90 command which leads to generate a pair of control signal at pins (6 and 7) so that pin (6) at logic one and pin (7) at logic zero. At this case the HDM move to shift right to 90° . Figure 4 shows different horizontal angles of HDM.

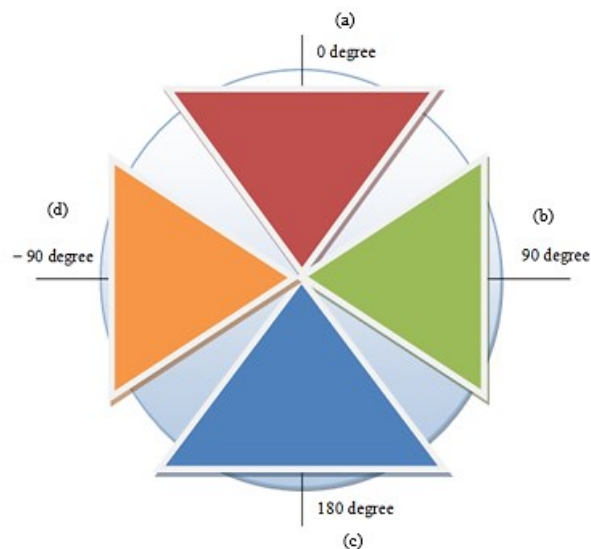

Figure 4. Different horizontal positions of HDM;
(a) default 0 degree, (b) shift right 90 degree, (c) shift right 180 degree, (d) shift left 90 degree

4.3. Case three: 180° shift right

When tone reading equal to (Q3Q2Q1Q0 = 0011) matched with press key 3, The there'd case will implemented to make the HDMSR180 command to executed for change the state of pin (6) to logic one and pin (7) to logic zero, this make the HDM move to shift right to 180° .

4.4. Case four: 90° shift left

The HDM shift left to 90° , this is the function of fourth case that implemented when the key number 4 is pressed. This leads to the implementation of the HDMSL90 command, which changes the state of pin (6) to logic zero and pin (7) to logic one. This case execute when the tone reading equal to (Q3Q2Q1Q0=0100).

4.5. Case five: default case

At this case the two motors HDM and VDM fixed at a default direction, so that the HDM fixed at direction zero of x-axis and VDM stopped at direction zero of y-axis as shown in Figures 4 and 5 respectfully. This case implemented when the key number 5 is pressed that lead to generate a binary tone reading value equal to (Q3Q2Q1Q0=0101) then execute the command DHAVDM, as a result to generate a control signals at pins (6, 7, 8, and 9) so that all these signal at logic zero.

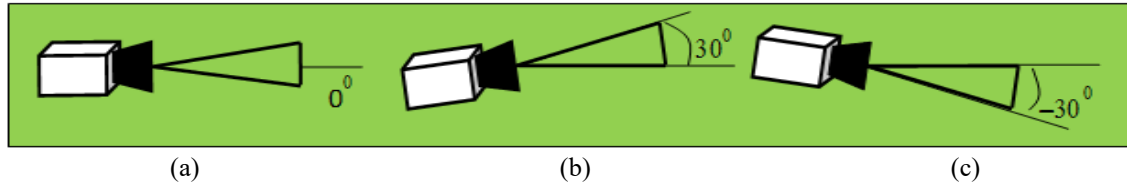

Figure 5. Different vertical positions of VDM of spy camera;
(a) default case, (b) up 30 degree, and (c) down 30 degree

4.6. Case six: vertical up 30°

The function of this case: move the VDM in vertical direction up to 30°. This case enable when key 6 is pressed, that lead to generate a binary tone value equal to (Q3Q2Q1Q0=0110) and allows to execute VDMU30 command will results a pair of control signals are generated at pins (8 and 9). So that pin (8) at high state and pin (9) at low state as explain in Figure 5 shows positions of different vertical angles of VDM.

4.7. Case seven: vertical down 30°

This case has implemented when key 7 is pressed that make the VDM move in vertical direction to down 30°. This is when execute VDMD30 command. This process is occur when the algorithm receive binary tones value equal to (Q3Q2Q1Q0=0111), as a result, a pair of control signals will generated at pins (8 and 9) in which, pin (8) at low state and pin (9) at high state.

4.8. Case eight: ON/OFF listen device

This case occur when key 8 is pressed, this lead to execute LDONOFF command when receiving binary tone value equal to (Q3Q2Q1Q0=1000). Executing the LDONOFF command generates a high-state control signal at pin (10), causing the excitation relay driver ULN2003 then excitation relay RL2 that's allowed the required power to reach the listening device to turn it to ON state. Because this relay is latch type then second signal with logic high at the same pin will turn it at OFF state then turn OFF listen device. The second signal is generated when key 8 is pressed a gain will cause to repeated the process at second time.

4.9. Case nine: ON/OFF spy devices

This case is activated when the key number 0 is pressed. The function of this case like the ON/OFF switch for any electric device that make all the spy devices and their drivers to turn ON or OFF depending on the control signal caused to control of relay RL1. Because the RL1 is a latch relay therefore the first logic high signal at pin (11) will enable the RL1 and the second logic high signal will disable it. This done when the input binary reading tone equal to (Q3Q2Q1Q0=1011) and the comment ADONOFF will be executed that result a logic one control signal at pin (11) of board will generated.

5. RESULTS

In this proposed research, different DTMF signal has been generated by pressing different keys on the keypad of user mobile phone. These signals send to remote place mobile phone through GSM network then transfer to the DTMF decoded in order to output four digital bits tones corresponding to the pressed key. The DTMF signals from nine different keys have been used to generate all the desired control signals used to implemented different actions. All these activates are shown in the Table 4. The Arduino sketch code used for writing the system algorithm and performing all analyzes by relying on the four digital tones received from DTMF.

Table 4. All practical executed command and actions of the proposed system

User phone keys	Implemented case name	DTMF decoder tone binary output bits (Q3, Q2, Q1, Q0)	Executed command	Action of spy camera Motors and listening device
1	horizontal search mode	0001	HDMASM	360 degree. Horizontal search
2	Shift right 90°	0010	HDMSR90	Shift right 90 degree
3	Shift right 180°	0011	HDMSR180	Shift right 180 degree
4	Shift left 90°	0100	HDMSL90	Shift left 90 degree
5	default case	0101	DHAVDM	Default position for HDM &VDM
6	vertical up 30°	0110	VDMU30	VDM up 30 degree.
7	vertical down 30°	0111	VDMD30	VDM down 30 degree
8	ON/OFF listen device	1000	LDONOFF	Listen ON or OFF
0	ON/OFF spy devices	1011	ADONOFF	All devices at ON or OFF

The spy camera rotation speed at horizontal search mode can be adjusted by the software so that it is possible to cover all site area 360° at different time periods, through half minute, one minute and two minutes. The one minute selected as the default search time period denoted as speed2. While the other two time periods are slow speed (speed3) or high speed (speed1). This is can be achieved by reprogramming the board. Figure 6 shows different time periods for horizontal search mode.

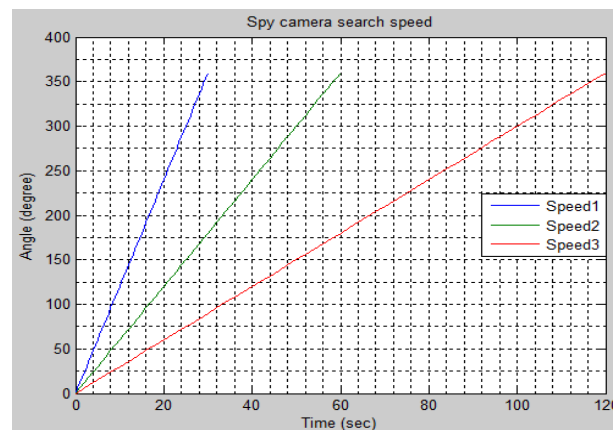

Figure 6. Different rotational time periods at horizontal search mode

6. CONCLUSION

The proposed research undertakes a suitable solution to implement wireless remote-control system using DTMF technology. One of the advantages of applications of this technology is its simplicity, cheapness and ease of use, which allows the user to understand its functions and the possibility of using it in a very short time. This device is used in security and intelligence institutions. The research will enable us to install this device wherever it is required to monitor its activities, especially in security hot spots, socially unstable places, the expected routes for the passage and transit of drugs and contraband, remote places that are difficult to reach, suspicious gathering places, and others. This proposed system enable to obtain good and effective information's without resorting to the presence of humans.

Use of such a device provides the ability to turn on / off and remotely control spy devices without the need for manual switching. The use of DTMF technology helps to use this system from different locations, without restrictions in place or time. The system has been simplified by allowing devices to be controlled by mobile pressed numbers. The user only needs a simple training to learn about numbers functions. Each number is assigned to perform one job. In this work, nine functions were identified. These functions represent moving the camera to searching in clockwise or anticlockwise, shift left or right, up and down or telling it to switch ON or OFF, it would enable the user to fully control the devices without any effort. An important point to remember is relying on local cellular networks available in every country and everywhere. Using this system can provide important security and intelligence requirements for the place to be monitored, which are, covering video and audio by simple means, not causing noise or excitement, remote control of the device without human intervention, and finally, rely on cheap and available technologies, which are DTMF and GSM networks.

REFERENCES

- [1] J. Kumar, A. Kumar, N. Kumar, P. Banal, R. Kashyap and S. Kumar, "Long Range Spy Robot Using DTMF Technology," *International journal for advance research in science and engineering*, vol. 6, no. 5, pp.81-89, 2017.
- [2] A. Tayab N., H. Rashid, M. A. Mahmud and Md. Shariful, "Design & Implementation of a Microcontroller Based Low Cost DTMF Controlled Acoustic & Visual Detecting Robot to Monitor Child & Aged Person," *International Conference on Electrical, Computer and Communication Engineering (ECCE)*, 7–9 February, 2019.
- [3] Sa. Maheshwari, S. Kumar and Se. Maheshwari, "Mobile Controlled Home Automation System Through DTMF Technology," *International Journal of Engineering Research and Management Technology*, vol. 3, no. 6, pp. 59-64, 2016.
- [4] A. Azeez, N. Sivanagaraju and M. Amilesh, "GSM Based Home Appliances Automation and Energy Auditing," *SSRG International journal of computer trends and technology (IJCTT)*, pp. 238-240, 2017.
- [5] A. S. Lande and B. P. Kulkarni, "Wireless Security Camera System," *International Journal of Innovative Technology and Exploring Engineering*, vol. 8, no. 10, pp. 2751-2754, 2019.

- [6] V. Darji, W. Dalmet, N. Dharamshi and S. Bhattachar-Jee, "Cell Phone Operated Remote Control Using DTMF," *International Journal of Computer Applications*, vol. 179, no. 35, pp. 23-37, 2018.
- [7] M. M. Josephine, "Design and Construction of a Remote-Control Switching Device for Household Appliances Application," *Advances in Science, Technology and Engineering Systems Journal*, vol. 2, no. 4, pp. 154-164, 2017.
- [8] P. Niladri and S. Tripathy, "Remote Position Control System of Stepper Motor Using DTMF Technology," *International Journal of control and automation*, vol. 4, no. 2, pp. 35-42, 2011.
- [9] S. Khakurel, A. K. Ojha, S. Shrestha and R. N. Dhavse, "Mobile Controlled Robots for Regulation D.C Motors and Their Domestic Applications," *International Journal of Scientific & Engineering Research*, vol. 1, no. 3, pp. 1-5, 2010.
- [10] S. Choudhary, S. Singh, V. and S. Dubey, "Cell Phone Control Robot Car," *International Journal of Advanced Technology in Engineering and Science*, vol. 2, no. 4, pp. 89-93, 2014.
- [11] Y. C. Cho and J. W. Jeon, "Remote Robot Control System Based on DTMF of Mobile Phone," *The IEEE. International conference on Industrial Informatics (INDIN 2008) DCC*, Daejeon, Korea, pp. 1441-1446, July 13-16, 2008.
- [12] S. Das, A. R. Ochi, M. S. Hossain and N. A. Siddique, "Designing & Implementation of Mobile Operated Toy Car by DTMF," *International Journal of Scientific and Research Pub Publication*, vol. 3, no. 1, pp. 1-7, 2013.
- [13] A. J. Al Mghawish, "A Practical Approach for Mobile Based Remote Control," *European Scientific Journal*, vol. 9, no. 18, pp. 194-201, 2013.
- [14] W.e Oludele, K. Shade O. and O. Samuel O., "GSM Based Electronic Interface for Remote Control of Electrical Appliances," *The International Journal of Computer Science and Applications*, vol. 1, no. 1, pp. 12-26, 2012.
- [15] E. C. Abunike, "GSM Control of Electrical Appliances," *International Journal of Technical Research and Applications*, vol. 3, no. 3, pp. 181-183, 2015.
- [16] K. Hassan, R. Siddiqui, Md. T. Islam, N. A. Siddique and S. M. E.b Uddin, "GSM Based Automatic Motor Control and Protection System," *International Journal of Advancements in Research and Technology*, vol. 2, no. 2, pp. 1-4, 2013.
- [17] E. Effah, F. L. Aryeh and W. K. Kehinde, "GSM Based Home Appliances Control System (HACS) For Domestic Power Users in Ghana," *4th UMaT Biennial International Mining and Mineral Conference*, pp. 58-64, 2016.
- [18] O. B. Olalekan and O. V. Toluani, "GSM Module in Remote Electrical Loads Control," *Asian Journal of Electrical Sciences*, vol. 6, no. 1, pp. 29-35, 2017.
- [19] S. Alla, B. and K. Babu, "Remote Control of Electrical Appliance Using Wireless Technology GSM," *International Journal of Science and Research (IJSR)*, vol. 2, no. 4, pp. 498-500, 2013.
- [20] K. A. Amusa, M. U. Olianipekun and O. O. Nuga, "Application of GSM for Home Devices Control," *International journal of computer applications*, vol. 167, no. 12, pp. 1-8, 2017.
- [21] A. Amin and M. N. A. Khan, "A Survey of GSM Technology to Control Remote Devices," *International Journal of u- and e- Service, Science and Technology*, vol. 7, no. 6, pp. 153-162, 2014.
- [22] A. R. Cruz1, S. D. Garraton, J. M. Jose and A. Malolos, "Model Case of Remote Switching Application System Via Telephone Line Using DTMF," *Presented at the DLSU Research Congress 2016 De La Salle University*, Manila, Philippines March 7-9 2016.
- [23] CM8870/70C datasheet, "California Micro Devices," 2011. [Online]. Available: <https://www.oztronics.com/data/cm8870.pdf>
- [24] Y. A. Badamasi, "The Working Principle of an Arduino," *2014 11th International Conference on Electronics, Computer and Computation (ICECCO)*, Abuja, 29 Sept.-1 Oct., pp.1-4, 2014.
- [25] D. Anusha, P. M. Sarma, M. N. SandhyaRani, "Appliance Remote Control Using Arduino," *International Journal of Latest Trends in Engineering and Technology (IJLTET)*, vol. 2, no. 4, pp. 35-41, 2013.
- [26] S. R. M. Zeebaree, H. M. Yasin, "Arduino Based Remote Controlling for Home: Power Saving, Security and Protection," *International Journal of Scientific and Engineering Research*, vol. 5, no. 8, pp. 266-272, 2014.
- [27] L29, L293D Quadruple Half-H Drivers, "Texas Instruments Incorporated," 2004. [Online]. Available: <https://cdn-shop.adafruit.com/datasheets/l293d.pdf>
- [28] K. O. Enalume and E. Okhueigbe, "Design and Construction of a Mobile Phone Based Home and Office Appliances Remote Switching System," *American Journal of Embedded Systems and Applications*, vol. 5, no. 1, pp. 1-6, 2017.
- [29] B. N. Getu, N. A. Hamad and, H. A. Attia, "Remote Controlling of an Agricultural Pump System Based on the Dual Tone Multi-Frequency (DTMF) Technique" *Journal of Engineering Science and Technology*, vol. 10, no.10, pp. 1261-1274, 2015.
- [30] A. K. Panigrahi, R. Ranjan, S. Bhoi and N. Kumari, "DTMF based Home Automation System," *International Journal of Advanced Research in Electrical, Electronics and Instrumentation Engineering*, vol. 6, no. 3, pp. 1355-1361, 2017.
- [31] R. Hakani, "DTMF Based Controlled Robot Vehicle," *International Journal for Scientific Research and Development-IJSRD*, vol. 2, no. 12, pp. 506-510, 2015.