

THESIS FOR THE DEGREE OF DOCTOR OF PHILOSOPHY

Shaping Future Opportunities for Biomass Gasification
- The Role of Integration

Johan Ahlström

Department of Space, Earth and Environment

CHALMERS UNIVERSITY OF TECHNOLOGY

Gothenburg, Sweden 2020

Shaping Future Opportunities for Biomass Gasification
– The Role of Integration
JOHAN AHLSTRÖM
ISBN 978-91-7905-399-4

© JOHAN AHLSTRÖM, 2020.

Doktorsavhandlingar vid Chalmers tekniska högskola
Ny serie nr 4866
ISSN 0346-718X

Division of Energy Technology
Department of Space, Earth and Environment
Chalmers University of Technology
SE-412 96 Gothenburg
Sweden
Telephone + 46 (0)31-772 1000

Printed by Chalmers Digital Printing
Gothenburg, Sweden 2020

Shaping Future Opportunities for Biomass Gasification
– The Role of Integration

JOHAN AHLSTRÖM

Department of Space, Earth and Environment
Chalmers University of Technology

ABSTRACT

A considerable number of studies indicate that biofuels produced from lignocellulosic biomass will most probably play a significant role in achieving the climate goals stated in the Paris agreement. Several candidate technologies could be implemented to produce these fuels, and one of the most promising is thermal gasification. Gasification is a robust technology that has been demonstrated successfully at industrial scale and shown to be able to achieve high conversion efficiencies and relatively low production costs. However, there are currently no large-scale plants in operation or under construction, since such plants are unable to compete with their fossil counterparts under current conditions. This thesis explores how different forms and levels of integration could facilitate deployment of large-scale biomass gasification for future production of biofuels. Three levels of integration are considered, a technological level, a process level and a value-chain level. Different integration concepts are then assessed with respect to these levels. From a technology perspective, the implications of switching feedstock are studied. At the process level, heat integration with existing sawmill plants as well as integration of an electrolyser unit with a gasification plant are investigated. From a value chain perspective, integration with the value chain for producing fuels for use the Swedish iron and steel industry is considered, as well as integration with the electricity system.

The results presented in this thesis indicate that the different integration options investigated can contribute to making biofuel production through biomass gasification more cost-efficient. Switching gasifier feedstock can lower biofuel production costs by up to 42%. Efficient heat integration with sawmills is the most attractive option to decrease production costs from a plant-owner perspective. Integration of a flexible gasification unit equipped with CO₂ capture capacity for either long-term storage or re-use as feedstock for biomethane production through the Sabatier reaction with hydrogen produced through electrolysis increases the economic competitiveness of the gasification unit, while stimulating increased construction of renewable electricity generation capacity. The thesis thus demonstrates that well-planned integration of biomass gasification plants can contribute significantly to making the technology more competitive.

Keywords: Biorefinery, Gasification, SNG, Biomethane, process integration, power-to-gas, hydrogen, heat integration, sawmill

List of publications & co-author statement

This thesis is based on the work presented in the following papers:

- I. Ahlström, J.M., Alamia, A., Larsson, A., Breitholtz, C., Harvey, S., Thunman, H. Bark as a feedstock in dual fluidized bed gasification – operability, efficiency and economics. *International Journal of Energy Research*, Volume 43, 3 January 2019, Pages 1171-1190
- II. Ahlström, J.M., Pettersson, K., Wetterlund, E., Harvey, S. Value chains for integrated production of liquefied bio-SNG at sawmill sites – Techno-economic and carbon footprint evaluation. *Applied Energy*, Volume 206, 15 November 2017, Pages 1590-1608
- III. Ahlström, J.M., Zetterholm, J., Pettersson K., Harvey, S., Wetterlund, E. Economic potential for substitution of fossil fuels with liquefied biomethane in Swedish Iron and steel industry – Synergy and competition with other sectors. *Energy Conversion and Management*, Volume 209, 1 April 2020, Page 112641
- IV. Zetterholm, J., Ahlström J.M., Bryngemark, E. Large-scale introduction of forest-based biorefineries: actor perspectives and the impacts of a dynamic biomass market. *Biomass & Bioenergy (Accepted for publication)*
- V. Ahlström, J.M., Harvey, S., Papadokonstantakis, S. Forest residues gasification integrated with electrolysis for production of SNG –modelling and assessment. *Computer Aided Chemical Engineering*, Volume 44, 1 January 2018, Pages 109-114
- VI. Ahlström, J.M., Walter, V., Göransson, L., Papadokonstantakis, S. The role of biomass gasification in the future flexible power system – BECCS or CCU? (*Submitted to Renewable and Sustainable Energy Reviews*)

Johan Ahlström is the principal author of Papers I-III and Papers V-VI. Jonas Zetterholm was the principal author of Paper IV, and also conducted the modelling-work in Paper III as well as contributing with reading, editing and discussions for Paper III. Johan Ahlström contributed with development of the research idea, as well as part of the writing and analysis for Paper IV. Elina Bryngemark contributed with development of the research idea, modeling and data in Paper IV. Viktor Walter contributed with modelling, data, reading and text editing in Paper VI.

Professor Simon Harvey was the supervisor of Paper II and contributed with supervision and reading of all other papers except Paper VI, he was also the main supervisor of the research project. Associate Professor Stavros Papadokonstantakis was the main supervisor for Papers V-VI. Dr. Karin Pettersson co-supervised the work of Paper II and III, as well as acting as co-supervisor throughout the research project. Associate Professor Elisabeth Wetterlund was co-supervisor of the work throughout the research project. She was also the main supervisor of the work presented in Paper III, and co-supervised the work presented in Paper IV. Professor Henrik Thunman was the main supervisor of Paper I which was co-supervised by Dr. Alberto Alamia. Dr. Anton Larsson and Dr. Claes Breitholtz contributed with experimental data and reading of Paper I. Dr. Lisa Göransson was co-supervisor of Paper VI where she contributed with editing and reading.

Related work not included in this thesis:

- A framework for techno-economic market evaluation of biorefinery concepts Bryngemark, E., Zetterholm, J., Ahlström, J.M. Presented at the SDEWES conference in Dubrovnik (October 2017)
- Decentralized plastic waste recycling through pyrolysis – a techno-economic feasibility study. Ahlström, J.M., Petersson, I., Svensson, A., Harvey, S., Papadokostantakis, S., Presented at the 3rd international conference on Functional Materials and Chemical Engineering (ICFMCE 19) in Bangkok (December 2019).
- Economic Evaluation of Large-Scale Biorefinery Deployment: A Framework Integrating Dynamic Biomass Market and Techno-Economic Models. Zetterholm, J., Bryngemark, E., Ahlström J.M., Söderholm, P., Harvey, S., Wetterlund, E. *Sustainability*, 2020, 12, 7126

Abbreviations & nomenclature

Abbreviations:

A.R. – As Received
BECCS – BioEnergy with Carbon Capture and Storage
BEV – Battery Electric Vehicle
CAPEX – Capital Expenditures
CCGT – Combined Cycle Gas Turbine
CCS – Carbon Capture and Storage
CCU – Carbon Capture and Utilization
CFB – Circulating Fluidized Bed
CG – Cold Gas
CHP – Combined Heat and Power
CP – Current Policy
CRF – Capital Recovery Factor
DAF – Dry Ash Free
DFB – Dual Fluidized Bed
DME – Dimethyl Ether
DPC – Direct Production Cost
DS – Dry Substance
DSC – Direct Supply Cost
EGD – European Green Deal
FPC – Fuel Production Cost
FRC – Feedstock Related Cost
GCC – Grand Composite Curve
GHG – Greenhouse Gas
GT – Gas Turbine
HHV – Higher Heating Value
HRSC – Heat Recovery Steam Cycle
HTL – Hydrothermal Liquefaction
HVO – Hydrogenated Vegetable Oil
IEA – International Energy Agency
iHD – Internal Heating Demand
IPCC – International Panel on Climate Change
ISI – Iron and Steel Industry
IVA – Kungliga Ingenjörsvetenskapsakademien
KPI – Key Performance Indicator
LBG – Liquefied Bio-Gas
LHV – Lower Heating Value
LNG – Liquefied Natural Gas
LPG – Liquefied Petroleum Gas
MILP – Mixed Integer Linear Programming
NG – Natural Gas
NP- New Policy
OME - Polyoxymethylene ethers
OPEX – Operational Expenditures
OR – Operational Revenues
O&M – Operation & Maintenance
PAH – Poly Aromatic Hydrocarbons
RED II – Renewable Energy Directive II
RME – Rape-seed Methyl Esters
RG – Raw Gas
R&D – Research & Development
SD – Sustainable Development

SNG – Synthetic Natural Gas
TPI – Total Plant Investments
TSSC – Total System Supply Cost
VMS – Variation Management Strategy
w.b. – Wet Basis

Nomenclature:

$n_{C,rg}$ - carbon content of raw gas
 $n_{C,v}$ - carbon content in volatiles
 $n_{C,ch}$ - carbon content in char
 $n_{O,f}$ - total oxygen supply to combustor
 n_i - moles of compound i in raw gas
 f – feedstock
 f_{rec} - fraction of raw gas recirculated to boiler
 O_{tr} – oxygen transport
 \dot{m} - mass flow
 p - product
 f – fuel
 Q – heat
 E - electricity
 X_g – char gasification
 λ_{otr} - oxygen transport
 η_{RG} - raw gas efficiency
 η_{CG} - cold gas efficiency
 η_{CH4} – biomethane efficiency
 η_{system} - system energy efficiency
 P - price
 O – flows leaving the system
 I - flows into the system
 fr - forest residues
 tfr - transportation of forest residues
 d - distribution cost of LBG
 el – electricity
 $el,cert$ - electricity certificates
 sr - sawmill residues
 wc - wood chips
 $Bmref$ - biomass sold in reference sawmill
 C – cost
 E_i - plant input or output of commodity i
 P_{tr} - transport cost
 d_{tr} - transport distance
 I - investment cost (Eq. 13)
 E_{BF} - annual plant biofuel production
 j – facility (Eq. 13)
 i – commodity (Eq. 13)
 $P_{fix,tr}$ - fixed transport cost
 $P_{dep,tr}$ - distance-dependent transport cost
 d_{tr} - transport distance commodities
 $E_{BF,tot}$ - total annual domestic LBG production.
 BF - biofuel and
 E - total LBG production (Eq. 14)

Table of Contents

ABSTRACT	III
List of publications & co-author statement	V
Abbreviations & nomenclature	VII
Chapter 1	
Introduction	1
1.1 Objective & Scope	4
1.1 Outline and overview of appended papers	5
Chapter 2	
Previous studies – different levels of integration	9
2.1 Technology & feedstock	9
2.2 Process	11
2.3 Value chain	12
2.3.1 Iron and steel industry	12
2.3.2 System feedback	13
2.3.3 Electricity system	14
Chapter 3	
Overview of processes and systems investigated	17
3.1 Biomass gasification and biofuel synthesis	17
3.1.1 Dual fluidized bed gasification with biomethane synthesis	17
3.1.2 Operation with bark feedstock	18
3.1.3 Direct blown gasification plant with biomethane synthesis	19
3.2 Process integration of biorefineries	19
3.3 Biofuel value chains	20
3.4 Power-to-gas	21
3.5 Electricity system	23
Chapter 4	
Methods	25
4.1 Methodological approach	25
4.2 Gasifier modeling	28
4.2.1 Stochastic model of DFB gasification	28
4.2.2 DFB gasifier performance extrapolation algorithm	29
4.2.3 Power-to-gas process model	29

4.3	Process integration.....	29
4.4	Value chain model.....	30
4.5	Geographically explicit value chain model.....	31
4.5.1	Multi-disciplinary framework for cost increase assessment.....	32
4.6	Electricity system model.....	33
4.7	Scenarios, analysis and performance indicators.....	34
4.7.1	Scenarios and analysis.....	34
4.7.2	Thermodynamic performance indicators.....	36
4.7.3	Economic and system performance indicators.....	38
Chapter 5		
	Results & discussion.....	41
5.1	Technology level and feedstock integration.....	41
5.2	Process integration.....	44
5.2.1	Sawmill integration energy balances.....	44
5.2.2	Sawmill integration economic performance.....	46
5.2.3	Electrolysis integration (power-to-gas concepts).....	48
5.3	Value chain integration.....	49
5.3.1	Iron and steel industry.....	49
5.3.2	Biomass price feedback.....	52
5.3.3	Electricity system.....	55
Chapter 6		
	Conclusions.....	61
Chapter 7		
	Outlook.....	65
	References.....	67
	Acknowledgements.....	75

Till Pappa

“Et ignotas animum dimittit in artes”
("And he turned his mind to unknown arts.")
— Ovid, *Metamorphoses*

Chapter 1

Introduction

As a measure to support achieving the targets set up in the EU's climate strategy, a European Green Deal (EGD) was launched during 2019 (European Commission, 2019). The scope of the EGD encompasses many aspects of society and aim specifically at decoupling economic growth and resource usage. Specifically, the package includes a large public spending program to promote transformation of energy system towards net zero greenhouse gas (GHG) emissions by 2050 (Tamma et al., 2019, European Commission, 2018). Ratification of the deal is ultimately left to each individual member state. In Sweden, the national climate goals call for net negative greenhouse gas (GHG) emissions after 2045 (Swedish Environment and Agriculture Committee, 2017); similar targets are stated by a large number of other EU member states.

To achieve these reductions, many measures will be necessary, including electrification of industry and vehicles, phase out of fossil-based power generation, improved energy efficiency, and carbon capture and storage (CCS). Energy systems research also highlights biorefineries producing biofuels and biochemicals as a key technological pathway towards a fossil-free society, especially in forest rich countries such as Sweden (Fulton et al., 2015, Connolly et al., 2014, Daioglou et al., 2019). The International Energy Agency (IEA) recently (2020) advocated for the need of a bioeconomy, stating that "The bioeconomy, an economy powered by nature and emerging from nature has, if managed in a sustainable way, major potential to help deliver the ambitions set by the Green Deal" (Palahí et al., 2020). The IEA has also previously stated that 17% of the cumulative emissions savings to be achieved by 2060 should come from bioenergy if the below 2-degree temperature increase target is to be reached (Brown et al. 2017). The future importance of bioenergy is supported by the Intergovernmental Panel on Climate Change (IPCC), who claims that in order to reach the 1.5-degree climate increase target, primary bioenergy use can be expected to be within the range of 40 to 310 EJ/a (Masson-Delmotte et al., 2018).

One technology concept that could enable the transition towards a bioeconomy is gasification of residual lignocellulosic biomass for production of liquid and gaseous biomethane, a so-called second-generation biofuel (IEA, 2020). Gasification is a technology suitable for large scale conversion of biomass to higher value energy carriers (Huber et al., 2006). It is a thermo-chemical process in which biomass is converted to a product gas. The product gas can be used to synthesise a variety of fuels, e.g. biomethane, bio-diesel and aviation fuels through the Fisher Tropsch process, or be used as a feedstock in the chemical industry (Arvidsson et al., 2015b, Bazzanella et al., 2017). During recent years, the biomass gasification concept has been developed substantially and there are several different types of gasification concepts (see e.g. Bolhàr-Nordenkamp et al. (2002), Weiland et al. (2012), Hannula and Kurkela (2012)).

Construction of pilot and demonstration plants has been highlighted as a key concept to enable widespread commercial production of advanced biofuels (Mossberg et al., 2018). Within the field of biomass gasification, years of research and development have resulted in the

Introduction

commissioning of pilot and commercial plants through the involvement of large, commercial, actors. Examples of such plants include the 140 MW_{biomass} Vaskiluodon Voima Oy plant in Finland (commissioned 2013) that produces syngas for co-combustion in a coal-fired power plant and the GoBiGas plant in Gothenburg, Sweden (commissioned 2014), a 20 MW_{biomethane} plant based on dual fluidized bed (DFB) gasification technology (Blomberg, 2014, Thunman et al., 2018). The GoBiGas plant is the only gasification plant integrated with a downstream fuel synthesis unit for conversion of 100% of the product gas to methane (Alamia et al., 2017a). However, operation of the plant was discontinued in 2018 and it is currently “mothballed”.

Regardless of past development and the clear confirmation that production of biofuels in commercial scale is possible, there is currently little to no ongoing construction of large-scale gasification plants with downstream upgrading of the product gas. The latest report by the IEA on development and the current status of biomass gasification states that that all ongoing development within the biomass gasification field is focused on local, small-scale, digester plants for production of biogas at e.g. farm locations (IEA, 2020). Furthermore, several pilot and demonstration plants have been closed due to lack of financial support (Hrbek, 2019). The main reason for this development is the difficulty to produce biofuels at a cost that can compete with fossil fuels, even though biofuels are exempt from CO₂ taxes. The concept has thus not crossed the “valley of death” into full commercialization; although many of the milestones required for achieving commercialization have been achieved.

Pettersson et al. (2019) studied the well-to-wheel costs for forest-based biofuels in Sweden and concluded that gasification-based production of biomethane can be profitable with current policy instruments. Nonetheless, the absence of economic incentive is often pointed out as the main reason for lack of production of second-generation biofuels. A report by the European Commission Sub Group on Advanced Biofuels highlights that biofuels, with a few exceptions, will remain more expensive than fossil fuels unless the cost of mitigating climate change are factored into the cost of producing and using fossil fuels (Landälv et al., 2017). Several academic studies also pin-point the importance of policy in creating long-term stability to create the conditions necessary for the development of biofuel production facilities (see e.g. Huenteler et al. (2014), Mossberg et al. (2018), Tsiropoulos et al. (2018)).

To achieve Swedish climate targets, different policy instruments have been implemented to increase the economic competitiveness of biofuels. For example, biofuels are exempted from energy and carbon taxes in Sweden (The Swedish Government, 2016). However, the tax exemption is only granted on an annual basis and it has been argued that such policy time horizons are too short, which creates uncertainty for investors (Peck et al., 2016). Therefore, a mandatory emissions reduction obligation (an obligation to reduce GHG emissions in a life cycle perspective per unit of energy by mixing in biofuels) was introduced for motor fuels in Sweden in 2017. According to the obligation, all fuel suppliers of petrol and/or diesel must comply with fixed levels of certified greenhouse gas emissions reduction compared to fossil gasoline and diesel fuels. Currently (2020) the penalty levels are 4 SEK/kg CO_{2eq} for petrol (~1280 SEK/MWh_{LHV}) and 5 SEK/kg CO_{2eq} for diesel (~1380 SEK/MWh_{LHV}). This should be achieved with an increase in drop-in biofuels, i.e. increasing the blend of biofuels into their fossil counterparts (The Swedish Energy Agency, 2017).

Introduction

Jafri et al. (2019) compared economic potential and technology maturity of six different pathways for biofuel production from lignocellulosic biomass. They concluded that one of the drawbacks with the emissions reduction obligation is that it only provides incentives for biofuel types that are suitable as drop-in fuels, e.g. HVO. Although many technologies are currently being developed, e.g. HTL and production of pyrolysis liquids from biomass, they have yet to be proven at large scale. According to the study, it is paradoxical that short-term priority is given to pathways with the lowest technological maturity. The mandate system also implies that fuel independence and fuel production from domestic feedstock are not favored over additional import. According to Torgnysson Klemme et al. (2019), 85% of the biofuels used in Sweden in 2019 were either imported or based on imported feedstock, despite the fact that Sweden has high quantities of renewable biomass available.

As the development of gasification plants for biofuel production is struggling, the shift to renewable electricity is also viewed by many as the main pathway to decarbonization of the transportation sector. Many sectors are seeing or are expected to see increased electrification, e.g. industry (The Royal Swedish Academy of Engineering Sciences (IVA), 2019) and the transportation sector where many major manufacturers are developing battery electric vehicles (BEVs). This is emphasized by Brown and Brown (2017) who discuss how the perception of biorefineries in the USA has changed with an increased focus on electrification as the main solution to decreasing GHG emissions from transportation. The costs of new technologies have decreased, e.g. the cost of lithium-ion batteries has decreased at an annual rate of 8% as BEVs have achieved commercial-scale production. This led the authors to conclude that bulk production of biofuels is unlikely, and that future transportation is more likely to be achieved with BEVs running on electricity.

As a result of the situation described above, there is a clear tendency to question whether to continue investigating biomass gasification technology. The development of second-generation biofuel production has not occurred as expected. Other options, such as electrification, are rapidly gaining ground as renewable energy options for the transportation sector. Nonetheless, there is still a broad consensus on the importance of further development of the bioeconomy remains and both the IEA and the European Union persist in their conclusions that biomass will make an important contribution to mitigating climate change (Waldheim, 2015) (European Commission, 2018). The conclusions by Brown and Brown (2017) are also contrasted by a recent report by the interest organization FuelsEurope (FuelsEurope, 2020). In their pathway to climate neutrality by 2050, they argue for a large need for low-carbon liquid fuels, where the majority is to be produced from lignocellulosic biomass. These fuels will be used for specific modes of transportation and alongside electrification and hydrogen technologies.

In conclusion, there is a broad support for the need for biofuels; it has been stated by researchers, refinery and chemical industry branch organizations as well as governmental organizations. Research on biomass gasification has shown that this is a technology suitable for large-scale production of second-generation biofuels from residual forest biomass. Furthermore, the importance of demonstration plants and of involving commercial actors in the commercialization process has been highlighted. Even so, the desired development has not yet started.

Previous research on technology development, transition and niche market management shows that niche innovations are rarely able to achieve major transformations without the help of broader forces and processes (Lovio and Kivimaa, 2012, Näyhä and Pesonen, 2014). Thus, there is a need to re-focus how the concept of biomass gasification can become commercially successful by adopting new business concepts or by introducing it in industrial sectors. The work in this thesis is based on the assumption that forest residues are a suitable feedstock for production of advanced biofuels, that gasification is a main candidate technology to achieve this objective and that by rethinking how gasification technology is implemented this objective can be achieved. There is a clear trend towards electrification of many sectors of society, including transportation and industry, and it is therefore important to investigate the potential role of gasification processes in such systems. It is highly likely that all types of technologies that are part of the energy system need to interact with and complement other technologies in the same system. This is an imperative condition for large-scale implementation of the technology to occur. Additionally, research has pointed out the importance of using biomass in sectors where other renewable options are limited. It is therefore of interest to investigate how gasification could perform in a context where it supplies specific sectors with feedstock or fuel. If this can be achieved with increased cost efficiency by switching to lower-grade, cheaper, feedstock or through suitable integration solutions with other industrial sectors, it could significantly increase the competitiveness of gasification-based concepts. The concept of process integration, either through heat, feedstock, or both, has been clearly identified in the literature as an option to increase the energy efficiency of the biomass gasification concept (Tock et al., 2010, Heyne et al., 2012, Holmgren et al., 2012, Alamia et al., 2017b, Celebi et al., 2019).

For biomass gasification to play a significant role in future energy systems, it will need to relate to, as well as coincide and interact with other aspects of the same system. Thus, there is a need to further study the technology from other perspectives, for broader investigation of potential implementation opportunities. It is possible to achieve multiple benefits and synergies by integrating the concept of gasification with other aspects of the energy system, by combining the technology with other types of industries or by integrating other types of feedstock. By redefining the role of gasification as one of complementing other aspects of the energy system, it can possibly increase energy efficiency and lower GHG emissions and costs; ultimately facilitating commercialization. If this is achieved, gasification of forest residues for production of biofuels and chemicals might fulfill the role it needs to in the transition towards a carbon neutral energy system.

1.1 Objective & Scope

The general purpose of this thesis is to evaluate opportunities to improve the competitiveness of biofuel production through gasification of forest biomass. This is done through an approach focusing on integration with other facilities as well as with other parts or aspects of the biomass gasification value chain. The evaluation ranges from introducing different feedstock types to combining the process with other major components of the energy system. The focus of the work is on investigating opportunities to implement existing technology in a new context or integrated with suitable industrial plants to reach synergies. Three different aspects of

integration were considered:

- Technology: integration that affects the process on a technological level.
- Process: integration that affects the entire biofuel production process site, in this work mainly internal heat recovery
- Value chain integration of the gasification system with other components of the energy system.

Investigation of these aspects were addressed through three research questions:

1. In what way do the considered aspects of integration contribute towards increasing the economic feasibility of the biomass gasification concept? (Papers I-VI)
2. What types of integration options should be prioritized in the construction of new plants? (Papers I-VI)
3. How does deployment of large-scale biomass gasification processes affect the energy system of which they become a part? (Paper IV & VI)

This thesis also concerns a fourth research question that relates to question 3 but is unrelated to integration, at least from the perspective previously defined.

4. How can methods be combined to study biomass gasification concepts in a dynamic system which is affected by their introduction in that e.g. price conditions might change? Furthermore, and related to question 3, do the results suggest that these types of methods provide useful insights? (Paper IV & VI)

Biomass gasification can be used to produce a variety of different chemicals and fuels. The focus of this work was not to evaluate and compare different types of end-products, and biomethane was selected as the main biofuel. Methane is a highly used fuel and chemical feedstock and it has previously been shown that it can be produced efficiently (see e.g. Gassner and Maréchal (2009) or Thunman et al. (2019)). It was therefore chosen as a generic representative of biofuels. In one of the appended papers (III), the end-use of the biomethane is specific, for all other cases it is unspecified and could thus be used for industrial fuels, transportation fuels or as a feedstock in chemical industries. In all papers, the geographic scope is limited to Europe and in most papers, it is specific to Sweden. All work was performed under the assumption that some level of support or CO₂ charge is implemented.

1.1 Outline and overview of appended papers

The work presented in this thesis is based on six appended papers, referred to by Roman numbers in the text:

- I. Bark as a feedstock in dual fluidized bed gasification – operability, efficiency and economics. Ahlström, J.M., Alamia, A., Larsson, A., Breitholtz, C., Harvey, S., Thunman, H. *International Journal of Energy Research*, Volume 43, 3 January 2019, Pages 1171-1190
- II. Value chains for integrated production of liquefied bio-SNG at sawmill sites – Techno-economic and carbon footprint evaluation. Ahlström, J.M., Pettersson, K.,

Wetterlund, E., Harvey, S. *Applied Energy*, Volume 206, 15 November 2017, Pages 1590-1608

- III. Economic potential for substitution of fossil fuels with liquefied biomethane in Swedish Iron and steel industry – Synergy and competition with other sectors. Ahlström, J.M., Zetterholm, J., Pettersson K., Harvey, S., Wetterlund, E. *Energy Conversion and Management*, Volume 209, 1 April 2020, Page 112641
- IV. Large-scale introduction of forest-based biorefineries: actor perspectives and the impacts of a dynamic biomass market. Zetterholm, J., Ahlström J.M., Bryngemark, E. *Biomass & Bioenergy* (Accepted for publication)
- V. Forest residues gasification integrated with electrolysis for production of SNG – modelling and assessment. Ahlström, J.M., Harvey, S., Papadokonstantakis, S. *Computer Aided Chemical Engineering*, Volume 44, 1 January 2018, Pages 109-114
- VI. The role of biomass gasification in the future flexible power system – BECCS or CCU? Ahlström J.M., Walter, V., Göransson, L., Papadokonstantakis, S. (Submitted to *Renewable and Sustainable Energy Reviews*)

The different biomethane production pathways investigated in this work are related to different parts of the generic value chain. The definitions differ between the different parts of the value chain considered, and the particular aspect of integration that is considered in each specific paper. Figure 1 shows how the appended papers relate to the parts of the value chain, but also to the integration level that is evaluated.

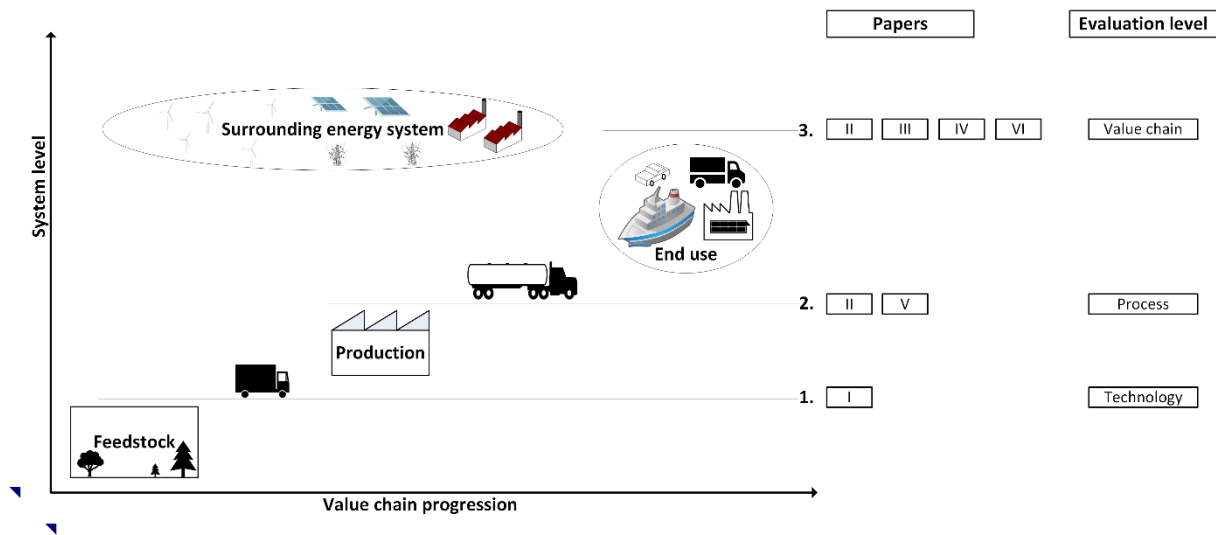

Figure 1. Overview of the appended papers and how they relate to the overall scope.

The system aspects considered include evaluation and validation of a specific technology, followed by process level evaluation, and finally value chain evaluation. The appended papers all focus on one or several aspects of evaluation, depending on the concept to be evaluated.

Paper I investigate the possibility of using shredded bark as the main feedstock in a DFB gasifier plant, thus integrating a new feedstock type into the biomethane value chain. Switching

Introduction

feedstock affects the gasification reactor and the immediate downstream product gas clean-up stages. As in the other works, the performance is quantified, partly, with economic measures.

Paper II is a value-chain study of producing Liquefied BioGas (LBG) through gasification processes integrated with sawmills, with the feedstock being entirely or partly provided from sawmill by-products. The study considers the entire value chain from feedstock to end-product, with a specific focus on the integration aspects between the sawmill and the gasification-based LBG plant.

Paper III builds upon the results of Paper II to investigate the concept of replacing fossil fuels in the Swedish iron and steel industry with LBG produced through gasification of biomass. The study considers the entire value chain.

Paper IV also builds upon the results of Paper II and investigates the different economic perspectives of plant owners and policy makers in the introduction process of large-scale production of LBG.

Paper V introduces concepts in which electricity is used to produce hydrogen, which in turn is used to increase the yield of gasification-based biomethane production. This paper focuses solely on modelling and evaluation of different process configurations for introducing hydrogen to the biomethane production process.

Paper VI is the continuation of Paper V. The plant configurations are simplified and evaluated in the context of an electricity system with high shares of generation from renewable sources. This paper focuses on the system of which the gasification concept is part.

Introduction

Chapter 2

Previous studies – different levels of integration

Chapter 2 consist of a literature study and presents work related to this thesis.

2.1 Technology & feedstock

Of the appended papers, only Paper I focus on the technology level as defined in Section 1.1. Technology refers to the process level in focus, which in this case was the gasification reactor with downstream gas cleaning. The aim of Paper I was to investigate the technical consequences as well as the economic performance of a commercial scale gasification plant if the feedstock is switched from wood pellets to bark with the goal of lowering production costs.

There have been multiple studies of the opportunities for using different feedstocks for gasification. One reason for this is that lower feedstock costs can potentially increase the plant's economic performance, provided that the plant efficiency can be maintained at sufficiently high levels. Another reason is related to environmental considerations in connection with repeated discussions about whether biomass should be considered carbon neutral. As an example, Chatham House published two reports in 2017 (Brack, 2017b, Brack, 2017a) expressing criticism on the sustainability of using forest biomass feedstock for energy purposes.

Cowie et al. (2017) challenged a number of aspects of the arguments presented by Chatham House. They emphasize that it is critical to distinguish between release of carbon that has been locked up for millions of years and the cycling of carbon between the atmosphere and the biosphere. Furthermore, they emphasize that when the impacts of bioenergy are quantified by comparing with a reference “no-bioenergy” scenario that describes the fate of residues and forests in the absence of the bioenergy market, the definition of this reference scenario has a strong influence on the outcome. They also argue that in most cases it is implausible to assume that the forest would remain unharvested and continue to grow if the biomass was not harvested and used for bioenergy purposes. Regardless of their differences, both Chatham House and their critics stress the importance of appropriate forest management for biofuels to contribute to decreased net emissions of CO₂ and they agree that residual biomass is the best feedstock alternative. It can consequently be concluded that biomass residues such as forest waste, bark or waste construction wood should be considered as carbon neutral if used for biofuel production.

There has been a discrepancy between experimental research and process/system research related to different types of feedstocks for gasification plants. Many types of feedstock have been tested in controlled, laboratory-scale, environments. For instance, Pfeifer et al. (2011) investigated a variety of different feedstocks under different operating conditions in a 100-kW pilot scale unit, including bark, wood chips and straw. The results of their study indicate that all the tested feedstocks are suitable for gasification, except for straw or other feedstocks with high ash-content that might cause operational problems. Similar studies have been conducted by other research groups (see e.g. (Carpenter et al., 2010)). However, conducting comparable measurements for industrial scale operations is complex. As a result, researchers evaluating the

system performance of gasification plants are forced to extrapolate data from lab-scale experiments when evaluating operation with a new feedstock. This is not inherently wrong, rather a fact to deal with when investigating new concepts. It is therefore the approach adopted in most of the papers included in this thesis. It is clearly important to evaluate new concepts before they are implemented at commercial scale and for complex, multi-mechanism processes such as gasification, there are limited alternatives for doing this and they all encompass compromises to accuracy (Alamia et al., 2016). Nonetheless, data measurements from industrial applications are valuable to the research community. Furthermore, owing to the limited numbers of past or present operating commercial plants, they are rare.

Paper I focused on integration of bark feedstock and on a thorough investigation of the technical performance of the gasifier reactor when operating with bark feedstock. Bark is a residue from sawmills and pulp mills with characteristics (physical size, composition, ash and moisture content) that differ considerably from wood pellets and other types of forest residues. The particularly high content of ash and alkali in bark limits the maximum allowable temperature levels in combustion boilers. As a result, bark is not an attractive fuel for power plant boilers. Currently, bark is mainly used as boiler-fuel for producing process steam or hot water. Bark is produced year-round in steady quantities since forest industry plants operate independently of the season. During periods of low heat demand in industry and district heating systems, demand for bark is very limited. Due to the restricted uses of bark as a fuel, it has a low price compared to wood pellets (Hokkanen et al., 2012), whereby it is a particularly interesting feedstock for large-scale gasification plants which can operate year-round.

Bark gasification has previously been evaluated at several facilities. Bark pellets were tested as feedstock in the dual fluidize bed (DFB) gasifier in Güssing Austria (Wilk et al., 2011). The test results indicated equal or higher cold gas efficiency for bark pellets ($0.6 \text{ kW/kW}_{\text{feedstock}}$) compared to other feedstocks, but also higher levels of dust in the product gas, due to the higher quantities of ash in the bark. The total tar levels for bark pellets were shown to be slightly higher compared to the levels when using wood of similar particle size. It was concluded that bark pellets are a suitable feedstock for DFB gasification, but also that the product gas might require modifications of the downstream gas cleaning equipment.

Other types of gasifiers have also been operated using bark as feedstock. The Värö 30 MW_{biomass} air blown, CFB gasifier was operated discontinuously from 1987 to 2014 with different feedstocks, including bark, to provide gaseous fuel to a lime kiln (Wadsborn et al., 2007). The process was operated using feedstock that was pre-dried at the plant site. Since air was used as gasification medium, the product gas had a low heating value (6-7 MJ/kg) with a nitrogen content unsuitable for further upgrading in a downstream synthesis unit (Waldheim, 2015). Bark gasification has also been evaluated in the pressurized entrained flow, oxygen blown pilot plant in Piteå, Sweden (Ma et al., 2016). The Piteå plant produced a syngas with a lower heating value of 7.82 MJ/kg dry feedstock, which is very similar to the values achieved in the same plant using stem wood (7.7 MJ/kg dry feedstock) (Weiland et al., 2012). Steam-oxygen gasification of bark was evaluated in an experimental, direct blown, pressurized, CFB gasifier by Kurkela et al. (2016). The study evaluated bark dried with a moisture content of 12.2%_{w.b.} for a test period of 215 hours and showed that stable and consistent operating of the gasifier

with bark is possible. Furthermore, the test results did not indicate any bed material sintering, or problems with ash deposits and soot formation in the tar and CH₄ reformer.

2.2 Process

Two of the appended papers focus on integration on a process level. In Paper II, the main focus was on how to best heat integrate gasification units with sawmills. In Paper V, a process perspective was adopted to determine how the efficiency of a gasification plant changes when it is integrated with the electricity system through a power-to-gas concept.

According to El-Halwagi (2006), process integration builds upon the fact that a chemical process is a system of integrated units and streams. Therefore, solutions to process problems and process optimization must adopt a perspective that considers the entire process as a single unit. One of the most well-established and systematic process integration methods is pinch analysis, which was originally developed for targeting for maximal process heat recovery in order to minimize utility heat consumption. The concept was developed by Flower and Linnhoff (1979) and has been further developed to focus on other types of utilities than heat, e.g. hydrogen and water. Pinch analysis methods are described in detail in Kemp (2011) and more recent developments are described in a review study by Klemeš et al. (2018).

In this work, process integration refers to pinch analysis applied to heat integration and, to a lesser extent, mass integration. The main idea is to heat integrate a gasification based LBG production plant with another industrial plant that operates with biomass feedstock and cascade heat between the processes so as to use heat as efficiently as possible. Both indirect and direct blown gasification occur at high temperature and generate large quantities of excess heat, hence there are significant energy savings to be made through heat integration. Mass integration opportunities investigated in this work refer to usage of residuals from one process as feedstock in another, thus increasing resource efficiency while decreasing transportation needs. Integration with an adjacent forest industry process plant is of particular interest since such plants have a continuous need for process heat, often have biomass by-products from their main processes, and have experience in operating large-scale biomass supply chains (Hosseini and Shah, 2011, Hagberg et al., 2016).

Previous studies of gasification-based biofuel production, comparing process integrated facilities to stand-alone production, confirm that co-locating and integrating biorefineries with existing industrial plants is beneficial from an energy perspective and results in lower fuel production costs. Heyne et al. (2012) showed how production of electricity as a by-product from a biomethane plant can be increased by a factor 2.5-10 if the plant is integrated with a CHP plant, depending on the type of biomass dryer that is used. Andersson et al. (2014) showed how the total energy efficiency of a biorefinery plant based on an entrained flow gasifier can be increased by 7 percentage points if the unit is heat integrated with an existing chemical pulp and paper mill. Consonni et al. (2009) investigated seven different process configurations for integration of a black liquor and biomass gasification plant with a Kraft pulp mill. Three different biofuels were investigated, Fisher-Tropsch liquids, dimethyl ether (DME) and ethanol rich mixed-alcohols. Their results show that the liquid fuel yield per unit of biomass is far higher for an integrated gasification plant than for a stand-alone gasification-based biorefinery.

Furthermore, due to the integration between the biorefinery and the pulp mill, the specific capital investment cost is lowered to a level of \$ 60,000-150,000 per barrel of diesel equivalent capacity per day, which is comparable to much larger coal-to-liquids facilities.

Arvidsson et al. (2015a) studied opportunities for integrating a direct blown, pressurized, CFB gasification plant for production of olefins in a steam cracker plant. An integrated plant producing bio-methanol through gasification on-site was compared to importing bio-methanol to the process. The methanol is used to produce olefins at the site and heat integration is performed through a heat recovery steam cycle (HRSC), generating electricity. The results show that the first option can lower the carbon footprint of the process by approximately 70% compared to a 50% decrease for the second case. Holmgren. et al. (2015) compared process integration for different gasification-based biorefineries in a case study. Comparisons were made to stand-alone units and the results were presented in terms of carbon footprint and net annual profit. The results indicate that integration with an industrial plant has positive impact on both carbon footprint and net annual profit for all scenarios. The fuel production cost is reduced by 7–8% if methanol is the end-product and by 12–13% if Fischer Tropsch diesel is produced.

2.3 Value chain

Integration with the value chain was studied primarily in Papers II-IV and VI. Papers II-IV focused on value chain design adopting a “traditional” well-to-tank value chain approach, Paper III investigated opportunities for using the gasification plant biomethane product as heating fuel in the Swedish iron and steel industry (ISI). In Paper VI the value chain is expanded to include the electricity system.

2.3.1 Iron and steel industry

Despite the ongoing trends towards electrification and increased efficiency, there are sectors that will require carbon-based feedstock and fuels in the foreseeable future. One such industry type is the ISI.

Previous research on using bio-SNG or liquefied bio-SNG for fossil fuel replacement in the ISI is limited. Heat integration of a bio-SNG plant with a steel industry heat treatment furnace was studied by Gunarathne et al. (2016). Syngas generated in the gasifier process was used as fuel for the furnace and excess heat was cascaded from the furnace to the gasification process, contributing to increased overall energy efficiency. Johansson (2016) investigated the effects on global GHG emissions of replacing liquefied petroleum gas (LPG) by bio-SNG in steel industry reheating furnaces. The results indicated that by substituting 220 GWh/a of liquefied petroleum gas (LPG) in a single Swedish scrap-based steel plant, fossil GHG emissions could be lowered by up to 52 kt/a. In a previous study by Johansson (2013) a scenario analysis was performed regarding economic incentives for a steel plant to invest in a biomass gasifier to substitute LPG with SNG produced from biomass pellets. The results showed that investment in a biomass gasifier would not be profitable in any considered market scenario, with production costs for bio-SNG ranging from 79-130 EUR/MWh. However, a more recent study on stand-alone biomass gasification for production of bio-SNG suggests that costs for production could decrease to approximately 60 EUR/MWh (Thunman et al., 2019).

Due to the limited demand of fossil fuels (3.9 TWh/a) used for other purposes than in blast furnaces in the ISI, it is unlikely that the steel industry alone will drive development towards the creation of an infrastructure for LBG production and distribution. However, demands for GHG emission mitigation have increased the demand for NG and LNG in specific branches of the transport sector, e.g. shipping and long haul trucking (Hoffman et al., 2017., U.S. Department of Energy, 2019). Large-scale use of NG and LNG for transportation could potentially help facilitate introduction of biomethane produced through gasification.

2.3.2 System feedback

Paper IV focuses on investigating how the changes in feedstock prices from large scale introduction of biofuel production from biomass gasification in turn affects the gasification plants. The feedback effects considered in Paper VI are discussed in a separate section.

Investments in large-scale forest-based biofuel production have been rare (Näyhä and Pesonen, 2014, Landälv et al., 2017) since investors typically opt for low-risk projects (Gnansounou and Dauriat, 2011, Peck et al., 2016). One perceived risk for biomass gasification plants is that of biomass feedstock cost (Thunman et al., 2019, Gnansounou and Dauriat, 2011), which can constitute up to 28% of forest-based biofuel production cost (Landälv et al., 2017). Furthermore, partial equilibrium modelling simulations have shown that large-scale implementation of biofuel production is likely to affect feedstock prices and resource allocation, e.g. (Kallio et al., 2018, Jåstad et al., 2019). In a Nordic context, biomass prices could increase by up to 35% (Mustapha et al., 2017) which would have a clear impact on economic performance of large-scale plants using biomass feedstock. Modelling studies have shown that large-scale forest-based biofuel production is likely to result in decreased profitability in the pulp industry due to increased pulpwood prices, and increased profitability in the sawmill industry due to increased demand for their by-products (Jåstad et al., 2019, Bryngemark, 2019, Chudy et al., 2019). Thus, the specific biomass assortment used as feedstock for biofuel production will influence which industries benefit or lose from the implementation of biofuel production (Chudy et al., 2019). Thus, these effects need to be considered in modelling studies and in the design of policy instruments aiming to reach the targeted levels of biofuel production.

Modelling approaches that consider biomass price as an endogenous variable are rare. To identify the performance of a biofuel supply chain, models that minimise the total system cost are often applied, see e.g. (Mafakheri and Nasiri, 2014, Yue et al., 2014, Zamboni et al., 2009). To account for uncertain price developments, price sensitivity analyses scenarios with systematic assumptions regarding the surrounding system can be applied (Harvey and Axelsson, 2010). Other studies have applied stochastic price processes to simulate future prices (Zhao et al., 2015). However, these approaches do not consider the impact on biomass prices from the introduction of large-scale forest-based biofuel production.

The strengths of a detailed technology representation in energy system models and the market representation and development in partial or general equilibrium models have previously been combined by using soft-linking (Krook-Riekkola et al., 2017, Andersen et al., 2015, Fortes et al., 2014, Mustapha et al., 2019). Similar modelling approaches have also been applied in climate change mitigation analysis (Hourcade et al., 2006). In a study by Mustapha et al. (2019),

a partial equilibrium model covering the Nordic forestry sector was hard-linked with an energy model covering the electricity and district heating sector in the Nordic countries to analyse the effects on the heat and power sector from large-scale forest-based biofuel production. The results indicated that studies not accounting for the competition for biomass may over-estimate future bioenergy production levels.

2.3.3 Electricity system

Paper VI studies the potential for integration of a gasification concept into the electricity system. The study assesses different process design configurations as well as the effects deployment of the gasification concept can be expected to have on the design of the electricity system.

In the electricity sector, a phase-out of fossil fuels is likely to lead to increased shares of electricity produced from intermittent sources (Troy et al., 2010). A recent study by Kan et al. (2020) suggests that wind power might represent up to a half of the electricity mix and solar power approximately 10% in Sweden in 2040. Similar predictions have been formulated by the Swedish Energy Agency (The Swedish Energy Agency, 2019). The same report predicts hourly ramping in electricity generation of up to 7500 MW in net load due to the variability of intermittent electricity generation. Such development induces more volatility in electricity generation and thereby more extensive and frequent changes in the electricity price (Woo et al., 2011). Thereby, it places high demands on the flexibility of the future electricity grid (Lund et al., 2015). A study of a generic grid with high integration of wind-power generation showed an increase in price volatility of 90% when the wind penetration level (% of total capacity) is increased step-wise from 5 to 50% (Astaneh and Chen, 2013). Similar results are reported for Spain in a modeling study by Martinez-Anido (2016), where the increased share of wind power generation increases price volatility by up to 7.5 \$/MWh/h (Martinez-Anido et al., 2016).

To maintain the grid balance, peaks and dips in delivery of electricity to the grid require variation management strategies (VMS). This will create opportunities for variable load application (Lund et al., 2015, Mathiesen et al., 2015). VMS functions by storing low-cost electricity and feeding it back to the grid when generation decreases, and the electricity price increases. Such storage can be both direct, i.e. batteries, but also indirect, e.g. storage of hydrogen or compressed air, and the process reversed for electricity production.

By applying gasification as a type of demand side management, it becomes an “indirect” part of the electricity system; such a concept is investigated in Papers V and VI. The concept builds on the idea of using electricity to produce hydrogen through electrolysis (Balat, 2008, Lund et al., 2015). Hydrogen is then used to enhance the biomethane production from the gasification plants, by using excess CO₂ as a reactant in the Sabatier process (Vogt et al., 2019). Such a concept would be a combination of bio- and electro-methane production. The concept builds on the idea that using cheap electricity for methane production would increase the output of the gasification process. However, increasing the demand for electricity also has feedback effects on the electricity system of which the methane production plant becomes part. One effect is that the value of electricity increases during periods of low demand, which in turn stimulates additional construction of renewable, intermittent, electricity production capacity. Large scale

production of electrofuels (fuels produced from electricity, water and CO₂) is a concept that has been highlighted for potential supply of renewable fuels for transportation, provided that the electricity and CO₂ originate from renewable sources (Brynolf et al., 2018). The concept of using captured CO₂ for production of fuels and chemicals is often referred to as carbon capture and utilization (CCU). CCU concepts are often build upon producing the hydrogen reactant through electrolysis, thus CCU is closely related to electrofuels; these concepts are often termed power-to-gas or power-to-liquid concepts, depending on the end-product. Another, potentially advantageous, pathway for biomass gasification is to store the CO₂ by-product (bio-CCS). Such a concept contributes to net negative greenhouse gas (GHG) emissions and would be profitable if policy incentives are put in place that pay providers of net carbon dioxide removal. Such a plant can be constructed to operate with the enhanced fuel production option (CCU) for all hours of the year or be built with the CCU option operating flexibly in combination with storage of the CO₂ or emitting it to the atmosphere. The balance between these two concepts is investigated in Paper VI.

The cost-competitiveness of electrofuels was studied by Lehtveer *et al* using a global energy system model, minimizing the cost of energy supply (Lehtveer et al., 2019). They conclude that electrofuels are unlikely to be cost efficient in the future, unless there are high restrictions on CO₂ emissions and restrictions or technical limitations for long-term storage of CO₂. They also state that in terms of cost-effectiveness, biofuels perform better than electrofuels in most of the cases investigated. They also concluded that it is more cost beneficial to use biomass fuel in the heating sector where CCS can be applied efficiently. According to Lehtveer et al. (2019) as well as Grahn et al. (2007), there is larger economic gain in using biomass in heat and power plants with BECCS rather than for biofuel production under high GHG emission constraints. However, their model has a global scope as well as a low time-resolution for modeling reasons. A global model is unable to capture specific geographical diversities which might influence the results. This work further elaborates on the same issue by studying a limited geographical region including the regional electricity systems. By so doing, it is possible to use a model with high time-resolution and study the benefits of specific technologies. High time-resolution models can capture the effects of rapid changes in electricity prices. Thus, it becomes possible to identify opportunities for technologies that can benefit from such changes that are hard to identify when using different modeling approaches. Moreover, this study provides additional insights into the potential dynamics of a process that produces biofuels, with the additional opportunity to both store CO₂ and use it to produce electrofuels (power-to-gas option).

The possibility of combining biomass gasification with a power-to-gas system for enhanced biomethane production has been studied previously. Rosenfeld et al investigated a power-to-gas system combined with biomass gasification for supplying fossil-free gas to a steel plant (Rosenfeld et al., 2020). They applied scenario analysis to compare fuel prices and concluded that the supply costs of biomass and electricity have the largest impact on the economic performance of the system. Clausen et al. assessed an integrated system consisting of anaerobic digestion in combination with thermal gasification and solid oxide electrolysis cells for SNG production, through thermodynamic modelling (Clausen et al., 2019). Hannula evaluated production of SNG from two production routes, biomass gasification and from CO₂ and

hydrogen produced from water electrolysis (Hannula, 2015). The concepts are compared to a hybrid process including the two concepts, similarly to the concepts addressed in this work. Hannula's analysis assumed fixed electricity prices and concluded that the gasification production route reaches the lowest production costs.

Celebi et al. (2019) studied a cogeneration concept where heat and fuels are produced from biomass in the same plant. The CO₂ by-product is released, captured and sequestered or seasonally stored and used for production of additional syngas during periods with low electricity demand. They concluded that the concept contributes to avoiding CO₂ emissions and that biomass cogeneration systems provide a good solution for long-term electricity storage. Bokinge et al. (2020) studied the possibility of producing OME via methanol from biomass gasification, a CCU approach with CO₂ from CCS was compared to a hybrid gasification/CCU approach. The results were assessed for energy performance and carbon footprint. Their results indicate that the energy efficiency is considerably higher for the gasification approach but that the largest emission reduction is achieved through the hybrid approach. Mohseni et al. (2012) studied the potential use of hydrogen and biogas production to enhance the production by reacting hydrogen with the excess CO₂ in the process. Their results indicate that the methane production could be enhanced by 110%. Gassner and Maréchal (2009) applied a super-structure optimization framework to assess the impact of the electrolyser on process design of biomass gasification plants in terms of economic, thermodynamic and environmental performance. They concluded that appropriate integration of an electrolyser can increase the exergy and energy efficiencies for both direct and indirect bubbling fluidized bed gasification. In a previous study by the same authors (Gassner and Maréchal, 2008), a multi-objective optimization algorithm was applied to a model of a plant producing SNG from wood through gasification, with an integrated electrolyser. The results show that electrolysis is an efficient and economically interesting option to increase the product gas output. Mesfun et al. (2017) studied a concept in which high temperature co-electrolysis of steam and CO₂ in power-to-gas and power-to-liquid processes could be used for producing chemical fuels from electricity. They conclude that large-scale deployment of the considered concepts is feasible, particularly when incentivized by carbon prices.

The open research literature shows that the subject of combining power-to-gas concepts based on water electrolysis with biomass gasification has been studied thoroughly. There are multiple studies investigating the suitability of the concept from several perspectives including: process modelling, techno-economic, thermodynamic and environmental assessments. However, the literature review also shows that there are very few studies that investigate how large-scale implementation of these concepts affects the system with which they are integrated.

Chapter 3

Overview of processes and systems investigated

This chapter provides descriptions of the main technologies and systems investigated in the thesis.

3.1 Biomass gasification and biofuel synthesis

3.1.1 Dual fluidized bed gasification with biomethane synthesis

The dual fluidized bed (DFB) gasification concepts (also known as allothermal or indirect gasification) involves two interconnected reactors; one combustion reactor for heat generation and one gasification reactor for fuel conversion. Bed material is circulated between the two interconnected reactors. Figure 2 presents an overview of the gasification reactor and gas cleaning sequences used in the GoBiGas plant (Alamia, 2016).

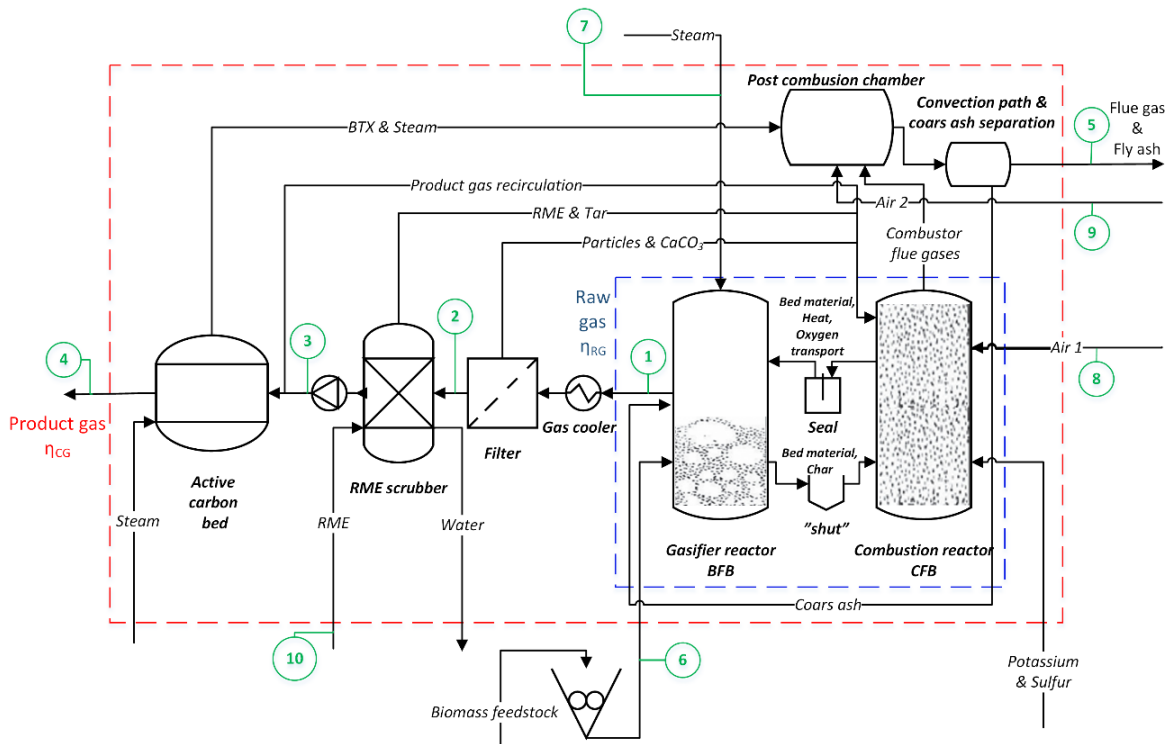

Figure 2. Process overview of the GoBiGas gasification process and gas clean-up section.

In DFB technology, the gasification process is divided into two parts. In the gasification reactor, the volatiles fraction and part of the char are converted to product gas. In the combustion reactor, the residual char and other streams are combusted to satisfy the heat demand of the gasification reactor. The gasification reactor is a bubbling fluidized bed reactor fluidized with steam and the combustion reactor is a circulating fluidized bed reactor (CFB) fluidized with air. The two reactors are connected through circulation of the bed material, which transports the following: heat from the combustion side (exothermic) to the gasification side (endothermic); unconverted char from the gasification side to the combustion side; ash and active components between the two reactors; and a certain amount of oxygen, depending on type of bed material.

The gas produced in the gasifier (hereinafter referred to as raw gas) consists of a mixture of steam, H₂, CO, CO₂, CH₄, C₂H_x, C₃H_x, C₄H_x, and aromatic hydrocarbons (PAHs). In the GoBiGas plant, the main aromatics produced are naphthalene, benzene, toluene, and other compounds up to chrysene. Due to the risk of fouling and clogging downstream equipment in the plant, it is important to remove aromatics from the product gas (the raw gas exiting the gas-clean up section).

Downstream of the DFB gasifier, a three stage gas cleaning system removes tar and other PAHs prior to feeding to the methane synthesis section (Alamia et al., 2017a). After the gasifier, the product gas is first cooled to around 160-240°C, thereafter particles are removed in a bag filter, then the heavier tar components (mainly naphthalene) are removed in a RME scrubber and remaining PAH compounds are removed through adsorption using activated carbon (Thunman et al., 2018).

The gasification concept investigated in Papers II-IV is assumed to adopt DFB gasification technology (see e.g. (Alamia et al., 2016)). Tar removal from the syngas is accomplished with a chemical looping reformer together with a cyclone. To adjust the gas composition, a water-gas-shift reaction is used. The methanation reaction occurs in an adiabatic two-step methanation unit, with intermediate separation of CO₂. The reason for using an adiabatic methanation unit, rather than an isothermal unit, is that the adiabatic unit is commercially available. It was also shown by Heyne & Harvey (Heyne and Harvey, 2009) that the impact of choice of methanation technology on overall system performance is negligible. The same study also showed that for adiabatic methanation, air drying of the biomass is more suitable from an efficiency perspective, compared to steam drying. Therefore, an air dryer was assumed in this study, drying the biomass to a moisture content of 20% (weight basis) before it is fed into the gasifier. The CO₂ removal step is assumed to adopt an amine-based solvent, in accordance with the investigation by Heyne and Harvey (2014). The bio-SNG plant achieves a biomass to LBG conversion efficiency of 69.4% (LHV basis) and has a specific electricity consumption of 0.115 MWh_{el}/MWh_{SNG}.

3.1.2 Operation with bark feedstock

During an experimental campaign conducted in November 2016, shredded bark was tested as feedstock in the GoBiGas plant. In Paper I, the resulting performance is compared with that of wood pellets, previously evaluated by (Alamia et al., 2017a). Feedstock compositions for both feedstocks are presented in Table 1. Shredded bark is a residue of the de-barking process of wood and is stored in piles outdoors. The moisture content is usually approximately 50%_{w.b.} (Andersson et al., 2014). The bark used in this evaluation was pre-dried to a moisture content of 20%_{w.b.} prior to delivery to the test facility. The bark was stored outdoors and due to rain, the moisture content increased, especially on the surface of the storage pile; the presented value is an average for each of three measurement days.

Table 1. Feedstock composition of bark and wood pellets presented in % of kg dry ash free fuel (DAF). B stands for bark and P for pellets, and the number indicate the moisture content level since this was the parameter that varied the most; e.g., B25 stand for shredded bark 25%_{w.b.} (wet basis) moisture content.

	B25	B30	B34	P8	Unit
Moisture	25.2	30.2	33.7	8.1	% A.R. ²
Ash¹	2.1	2.4	2.3	0.3	% A.R.
Volatiles	76.5	75.8	75.3	80.9	% DAF
Char	23.5	24.2	24.8	19.1	% DAF
LHV	20.3	19.8	20.7	18.8	MJ/kg DAF

¹ silicates not included

² A.R. = As received

The fraction of char and ash in the feedstock is higher, resulting in a lower volatile fraction.

3.1.3 Direct blown gasification plant with biomethane synthesis

In Papers V and VI, the biomethane production plant is assumed to adopt a direct, oxygen blown gasifier unit. A water electrolysis unit produces a clean stream of oxygen, which constitutes an additional benefit. In this work, the direct blown gasifier was not rigorously modeled; it was based on experimental data and models previously developed by Hannula and Kurkela (2012). The raw gas leaving the gasifier contains H₂O, H₂, CO₂, CO, CH₄, H₂O, inorganic impurities (e.g. H₂S) and organic compounds such as tars. The ash and traces of char in the raw gas are removed in a cyclone, thereafter H₂S is removed. In a pre-methanation step, the ratio of H₂/CO is adjusted through the water-gas-shift reaction. The methanation reaction occurs in a series of three adiabatic, fixed bed, reactors. The gas is then cooled, and remaining H₂O is removed through a flash reactor. Thereafter, the product gas contains solely CO₂ and CH₄. The CO₂ is removed or converted to CH₄ in a final upgrading sequence, which is varied for four different process configurations.

3.2 Process integration of biorefineries

In Paper II, integration of a gasification-based biorefinery with a generic Nordic sawmill is investigated. The concept assumes that biomass residues are available in large quantities at sawmill sites and takes into consideration that sawmills have a low-temperature heat demand for drying of sawn wood. If the biomass residues are used as feedstock for a gasification plant located at the sawmill site, the excess heat from the biorefinery plant can be used in the sawmill process. To increase the energy efficiency of the process, the heat flows are cascaded through an integrated heat recovery steam cycle (HRSC). The steam is used for electricity production in a back-pressure steam turbine with extraction ports at the pressure levels required to cover the process steam demands.

The integration of the gasification plant with the sawmill influences the performance of the total value chain. The size of the gasification plant determines the amount of excess heat that is available for integration with the sawmill and, conversely, the size of the sawmill determines the amount of residue feedstock that is available. If the gasification plant is significantly larger than the sawmill, the excess heat generated will exceed the heat demands of the sawmill and

the excess steam can be used to generate electricity in a condensing steam turbine unit. In addition, the feedstock requirements of the gasification plant will also exceed the by-product streams from the sawmill; additional feedstock will therefore need to be imported to the process. A large gasification process also entails longer transportation distances for the LBG product.

To investigate how these aspects affect the total GHG and economic performance of the integrated concept, the LBG plant was assumed to be sized according to five possible size-limiting factors:

- *Case 1 – Available sawmill residues.* The LBG plant is sized to use all available sawmill residues (sawdust, wood chips and bark) as feedstock.
- *Case 2 – Available sawmill residues excluding wood chips.* The LBG plant is sized to use all available sawmill residues (bark and sawdust) but not the wood chips, which are instead assumed to be sold as feedstock for pulp production. In this case, there is not enough excess heat from the LBG plant to cover the heat demand of the sawmill. A fraction of the available sawmill residues is therefore combusted directly in a boiler to produce steam for the integrated HRSC.
- *Case 3 – Forest residues uptake area.* The required uptake area for timber logs to the sawmill was estimated. It was assumed that 80% of all available branches and tops within the same area are imported and used together with the sawmill residues as feedstock to the LBG process.
- *Case 4 – Sawmill heat demand.* The LBG plant is sized according to the sawmill's heat demand. The feedstock supply rate to the LBG plant was determined based on the requirement that the excess heat released by the LBG plant is sufficient to satisfy the heat demand of the HRSC powerhouse assumed to consist of a back-pressure steam unit (without a condensing unit).
- *Case 5 – Large scale.* A fixed production of 500 MW LBG was considered. 500 MW represents a scale of production with a feedstock intake similar to that of a large Nordic pulp mill (Delin et al., 2005). For this case, the electricity production through the HRSC is maximized.

Two different sawmill sizes were considered; 50,000 and 500,000 m³/a of sawn dry wood, representing typical sizes for small and large mills in Sweden. Sawmill data was based on Anderson and Toffolo (2013). All results are compared to a reference case where part of the biomass residues from the sawmill is used in a heat-only boiler to satisfy the internal sawmill heat demand, while the rest of the residues are sold.

3.3 Biofuel value chains

In Papers II-IV a full biomass to biofuel value chain is considered, applying a Swedish perspective. This value chain is presented in Figure 3.

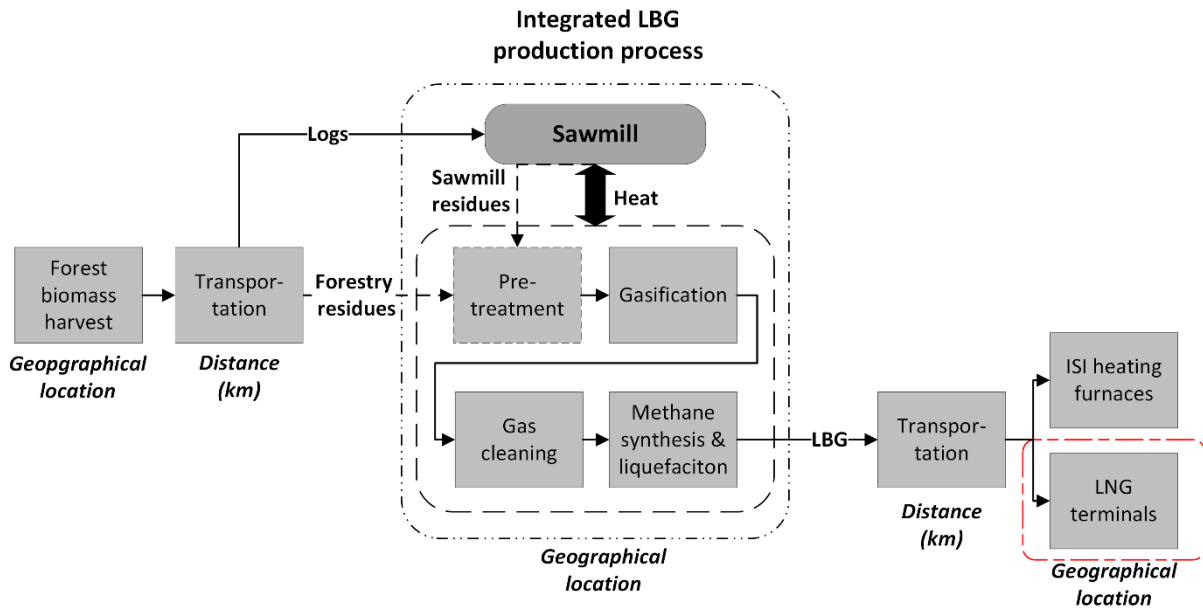

Figure 3. The value chain studied in Papers II-IV. The product is assumed to be delivered to LNG terminals in Papers II and IV (see red dashed line).

In Papers II and IV, the LBG is assumed to be delivered to one or several Swedish LNG terminals, but the ultimate end use of the product is unspecified. In Paper III, LBG was assumed to be used as fuel for firing furnaces in the Swedish steel industry. A specific demand from “other sectors” was also considered and assumed to be covered by delivery of the product to LNG terminals, as in Papers II and IV.

Papers III and IV use the cases developed in Paper II as input data in the value-chain model. An inventory of all Swedish sawmills was conducted in 2019 and used as input sites for potential integration according to the different cases presented in Paper II. For Paper III, Swedish steel plants were also mapped for the purpose of estimating the transportation distance for the LBG product.

In Paper III, LBG was assumed to be used either in steel plants, or in other sectors. Cases 1, 2, 4 and 5 developed for Paper II were compared. Regarding the ISI, 16 industrial plants in Sweden currently use fossil fuels in furnaces and for iron pellet production. *Other sectors* were not explicitly defined but include e.g. heavy-duty vehicles for road transport, and shipping. Existing as well as planned LNG terminals (import and bunkering) in, or close to, Sweden were included, based on data from Gas Infrastructure Europe (2019). All terminals were assumed capable of handling LBG.

In Paper IV, the system boundaries and assumptions were essentially identical to those in Paper III with the difference that the product was assumed to be used as a vehicle fuel. The paper conducted further comparisons of Cases 1, 4 and 5 developed for Paper II and Paper III.

3.4 Power-to-gas

Hydrogen produced through electrolysis can be used to produce methane through the Sabatier reaction with CO₂. CO₂ is inert in the gasification process; it is formed both from combustion

and by the water-gas-shift reaction and is finally removed to sustain a product of sufficient quality. In this way, the product output of the process is enhanced while the energy loads of the CO₂ separation sequence are decreased.

After the methanation section, the gas (containing only CH₄ and CO₂) is fed into the final CO₂ removing sequence. Two specification values are considered for the Wobbe index of the biomethane product, corresponding to the A and B standards of the Swedish national gas grid. The Wobbe index essentially limits the concentrations of both CO₂ and H₂ in the gas product. A-grade biomethane is produced if possible, since it can be sold at a higher price, otherwise B-grade biomethane is produced instead. Four possible configurations for the final CO₂ removal sequence and combination with the Sabatier process were investigated (see Figure 4):

Configuration (i): the gas from the methanation section is mixed with H₂ from the electrolyser and fed to the Sabatier reactor where H₂ reacts with CO₂ to increase the share of CH₄ in the gas. The gas is cleaned of the remaining CO₂ in a sequence of two amine-based CO₂ separators. The yield of the Sabatier reactor entails that there will be H₂ left in the gas after the reactor if all CO₂ is to be converted. Since configuration *i* does not include a H₂ separation sequence and the gas standards limits the concentration of H₂ in the gas product, there will always be CO₂ in the gas after the Sabatier reactor.

Configuration (ii): H₂ is added to the gas mix in sufficient quantity to convert all remaining CO₂, thus avoiding the need for a CO₂ removal step. This configuration requires that the fraction of H₂ in the gas must be decreased, which is achieved with a H₂ separation unit. The separated H₂ is recirculated back to the mixing step before the Sabatier reactor.

Configuration (iii): CO₂ is separated from the product gas and mixed with H₂ in the Sabatier reactor. The produced gas, containing mainly CH₄ but also some remaining CO₂, is dried and recirculated to the inlet gas stream before the CO₂ removal step.

Configuration (iv): similar to Configuration (iii), with the difference that a H₂ separation step is added to the process after the drying step. This results in a process in which all the CO₂ in the raw gas can potentially be reacted to CH₄, since the excess H₂ can be removed.

Configurations (i) and (iv) from Paper V were further evaluated in Paper VI.

Overview of processes and systems investigated

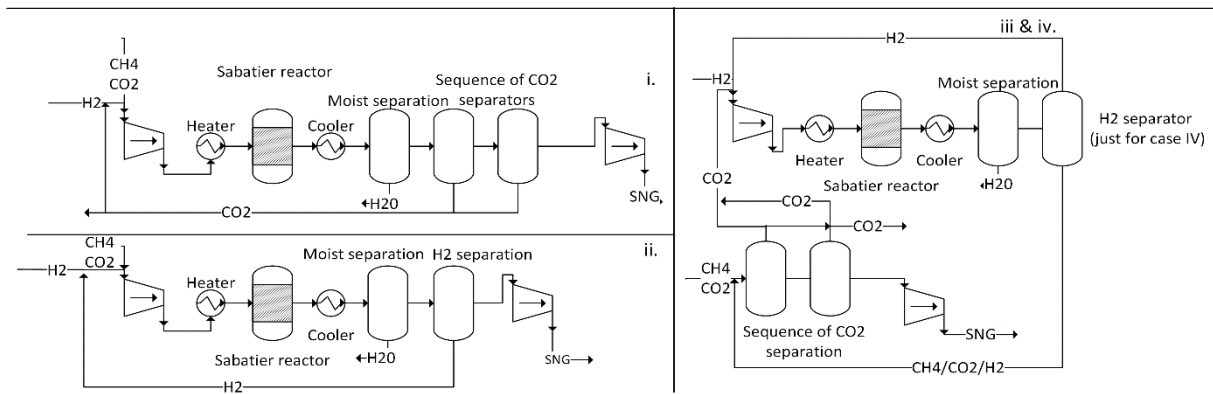

Figure 4. Overview of the final CO₂ removal sequence for the four configurations.

The main difference between the process configurations investigated is the degree of operational flexibility. Configuration (i) is limited by the fraction of CO₂ that can be reacted, since there will be H₂ in the produced gas if all CO₂ is reacted to methane. Configuration (ii) is limited by the absence of CO₂ separation units, meaning that the Sabatier reactor must always be fed with enough H₂ to achieve full conversion of the CO₂. Thus configuration (i) is more flexible than configuration (ii). In configurations (iii) and (iv), the CO₂ is separated before it is reacted with the H₂. Here configuration (iv) is the more flexible option; enough H₂ to react all CO₂ can be fed to the process, since a H₂ separation sequence is included.

Candidate electrolyser technologies include alkaline and Polymer Electrolyte Membrane (PEM) units (Brynnolf et al., 2018). PEM technology is characterized by a shorter start up time, but a lower efficiency. Alkaline electrolyser technology has reached a higher development level and was therefore selected for this work.

3.5 Electricity system

A simplified description of the system studied in Paper VI is presented in Figure 5. Process configurations (i) and (iv) from Paper V (see Section 3.4) were further studied in Paper VI. The combined gasification/electrolysis process generates biomethane, which is either used within the electricity system for generation of electricity or exported outside of the system boundaries at a fixed price, to be used as a fuel or as feedstock in the chemical industry. Exported biomethane thus provides an income to the system. A fixed base NG price is specified exogenically. The CO₂ charge is applied to all CO₂ emissions inside the system, but also affects the export price of methane since the charge is added to the base NG price. The CO₂ charge is also represented in the system so that negative emissions of CO₂ (BECCS) gets credited with a positive charge, i.e. an income.

Overview of processes and systems investigated

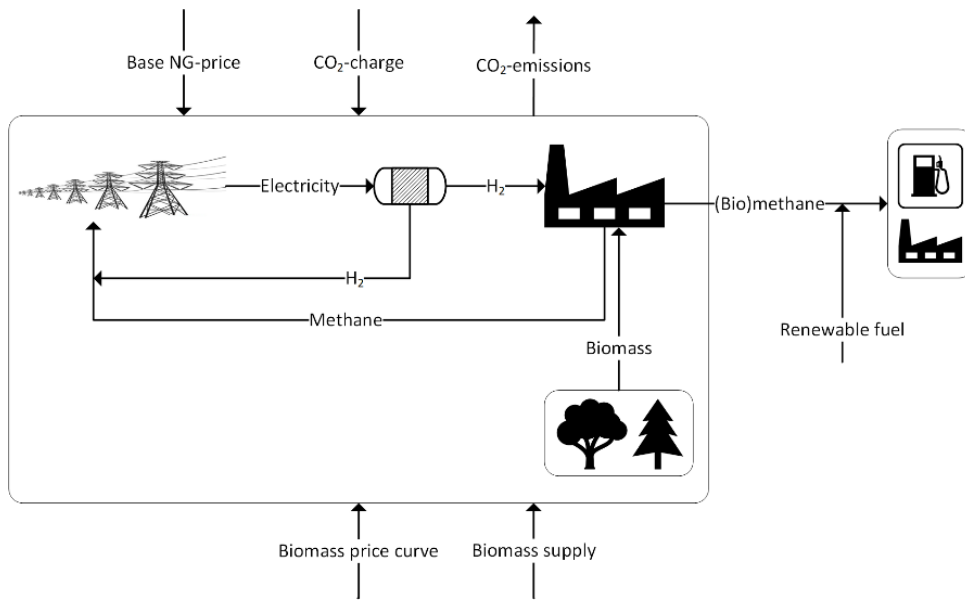

Figure 5. The system boundaries of the system considered in Paper VI.

Chapter 4

Methods

This chapter summarizes the methodological approach adopted for the thesis as a whole, as well as the individual models, methods and performance indicators applied in the different papers. No summary of input data is presented in the thesis; the reader is instead referred to the appended papers.

4.1 Methodological approach

In this work, integration refers to a number of concepts that apply to single or multiple aspects of the value chain. Thus, there is a need for several different methods and perspectives to perform the evaluation.

Six different models were used for the evaluations presented in this thesis. Figure 6 shows the system boundaries applied for the modeling of the different pathways that were evaluated.

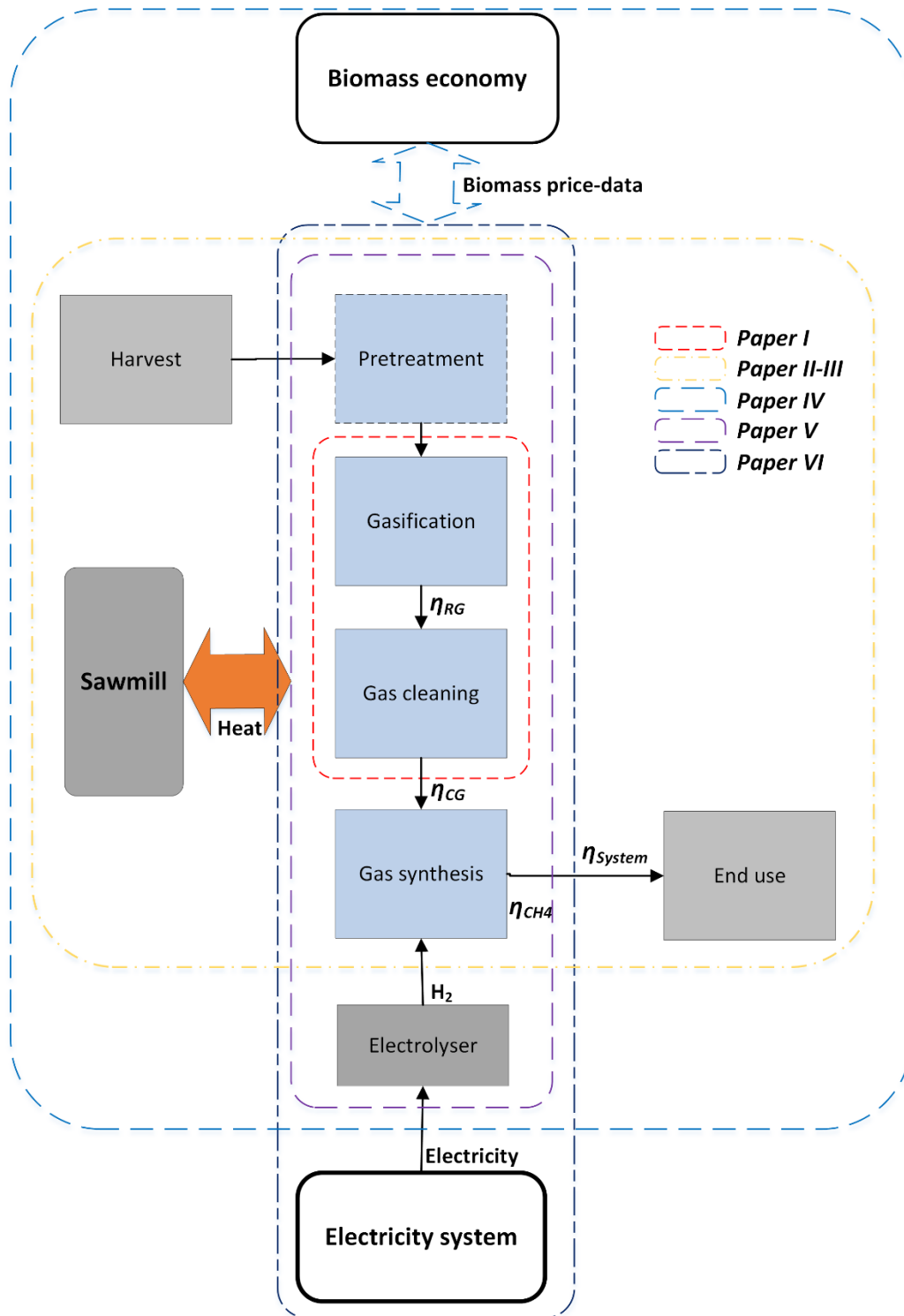

Figure 6. Overview of modeling system boundaries as well as main energy and mass flows. See Section 4.7 for definitions of the efficiency indicators indicated in the figure. The light blue boxes indicate the process steps of the gasification plant.

In Paper I, the aim was to quantify the performance of the gasification plant and the impact on plant economic performance, related to switching to bark feedstock. The performance of the overall plant was estimated based on additional assumptions regarding the rest of the plant. A model was developed that adopts a stochastic approach to reduce the uncertainty of the

Methods

gasifier's energy and mass balances. A detailed technical model captures how operation of the plant changes for different fuel characteristics and enables accurate performance estimation. The system boundary of the model includes the gasifier and downstream gas cleaning steps, as displayed by the red line in Figure 6. All modeling was performed using Matlab.

In Paper II, the aim was to evaluate how the sizing of a gasification plant integrated with a sawmill affects the performance of the entire value chain. For this purpose, a full value chain model was developed, as shown in Figure 6 (orange line). The model includes feedstock transportation, the gasification based LBG synthesis plant, the sawmill and distribution of the LBG product to the end-user. The LBG plant was simulated using Aspen Plus (v. 8.8) and a Matlab sub-model was used to optimize the process integration between the LBG plant and the sawmill. The software ArcGIS (esri, 2018) was used to map the sawmills in Sweden and estimate transportation distances for biomass feedstock and the LBG product.

In Paper III (yellow line) the aim was to study the potential of replacing fossil fuels used for heating purposes in the Swedish ISI with LBG produced from sawmill integrated biomass gasification. The study applies the same value chain scope as Paper II. However, to get a better estimation on the impact of transportation, competing biomass use and biomass supply, a geographically explicit representation of the gasification base biofuel plants was applied. Furthermore, the study also considered the interplay with LBG demand from other sectors, using the GAMS-based linear programming tool BeWhere Sweden (Wetterlund et al., 2013).

Paper IV adopts the same perspective as Paper II. However, here the aim was to study the difference in economic perspective between policymaker and plant-owner when implementing LBG production at large scale. The study investigates the impact that implementation of large-scale biofuel production has on feedstock demand and market prices and how this affects the profitability of the LBG plants. To achieve this objective, data regarding the feedstock market was iterated between the BeWhere Sweden model and an input-output economic model. The system boundaries are highlighted by the light blue line in Figure 6.

In Paper V, the aim was to identify the most efficient process configuration for integration of hydrogen as additional feedstock to the gasification-based biofuel production plant. The system boundary shown by the purple line in Figure 6, encompassing the entire plant, from pre-treatment and drying to finished product, was modeled using Aspen Plus process simulation software (v. 8.8).

Paper VI (dark blue line) is a direct continuation of Paper V with the aim of placing the concepts developed in the latter in the context of the electricity system to which they belong. Furthermore, to capture the importance of the flexibility of the concept, it is important to incorporate time as a variable. For this purpose, the linear optimization tool ENODE was applied (Göransson et al., 2017). This model was originally developed for the purpose of investigating planning and scheduling problems in electricity systems. Surrogate models of the concepts developed in Paper V were created in Matlab, whereas the ENODE model is based on the mathematical programming software GAMS.

A short summary of the different models applied and the main methods they are based on are presented in the following sections, together with the key performance indicators (KPIs) applied in this work.

4.2 Gasifier modeling

Throughout this work, two different gasification concepts were considered, dual-fluidized bed gasification (DFB) and direct, oxygen blown, gasification (Papers V and VI), described in Sub-section 3.1. The DFB gasifier considered in Paper I was modelled explicitly, whereas the characteristics of the final gas-upgrading to methane was based on data from previous work, thus adopting a grey-box approach. Mass and energy balance data were taken from literature for the other papers (black box).

4.2.1 Stochastic model of DFB gasification

The modeling in Paper I is based on data collected during a measurement campaign performed at the GoBiGas plant during ten days in November 2016. To evaluate the data, a method presented by Alamia et al. (2016) was applied. The method was used in earlier work for evaluation of performance of the GoBiGas plant operating with wood pellets. The corresponding results constitute the reference case in the comparison made in Paper I. To enable economic performance evaluation for operation with bark feedstock with the same moisture content as pellets, a performance extrapolation model was developed. All modelling was done in Matlab. An overview of the performance evaluation calculation procedure used in Paper I is presented in Figure 7.

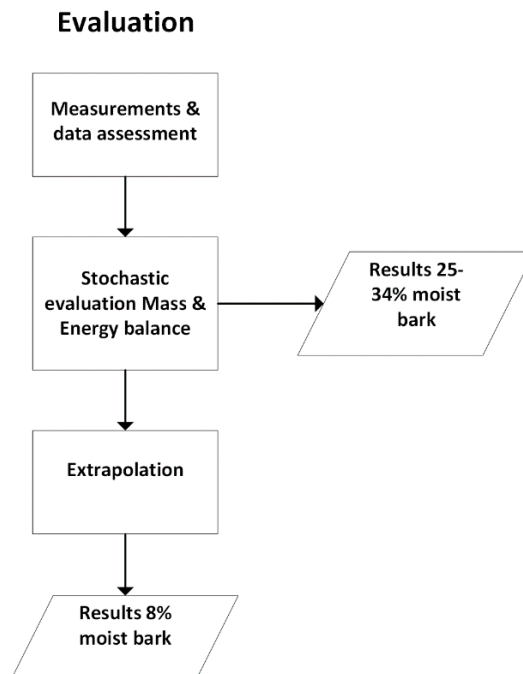

Figure 7. Overview of the performance evaluation calculation procedure

The set of measurements from the bark gasification campaign conducted at the GoBiGas plant constitutes the inputs to the mass and energy balance model.

Mean values as well as standard deviation values were first calculated for the measurement data for the process streams indicated in Figure 2. This data was then used to calculate the mass and energy balances for the complete gasification section of the DFB system.

4.2.2 DFB gasifier performance extrapolation algorithm

During the measurement campaign, bark with a moisture content ranging from 25%_{w.b} to 34%_{w.b} was used as gasifier feedstock. To estimate the performance of the DFB operating with a moisture content outside of this range, an extrapolation algorithm was developed. The results from the stochastic data evaluation model constitute the input data to the extrapolation algorithm.

The extrapolation algorithm is based on the same equations used for the mass and energy balance model and aims to predict process operating data for operating conditions outside of the range of conditions corresponding to the measurement campaign. The algorithm can handle variation of several operating parameters simultaneously and recalculates the energy and mass balances of the system. In this study, only the effect of drying is investigated, by calculating performance for a moisture content of the bark feedstock of 8%_{w.b}. (same as pellets). The calculated performance can then be compared with the performance for operation with wood pellets with the same moisture content. For a thorough description of the extrapolation algorithm, see Paper I.

4.2.3 Power-to-gas process model

To assess the possibilities of utilizing hydrogen produced by electrolysis in a direct blown gasification process, four different process configurations were identified and modeled (see Section 3.4). All modeling in Paper V was performed using Aspen Plus (v 8.8). The main process unit operations of the gasification process were not modeled rigorously (based on kinetics), with the exception of the methanation section. The Sabatier reactor was modeled as a plug flow reactor with Langmuir-Hinshelwood-Hougen-Watsonis kinetics, as described by Schlereth (2015).

The price of electricity, and thereby the cost of hydrogen production, is essential for assessing how the different process concepts perform. To capture the impact of changing electricity prices, sensitivity analysis was performed with respect to the feed flowrate of H₂, together with the recirculation rate of CO₂.

4.3 Process integration

The value chain consisting of a liquefied biomethane production plant based on DFB gasification technology integrated with a generic Nordic sawmill was evaluated in Papers II-IV. Mass (feedstock) integration and heat integration were the main aspects considered. Heat integration aspects were also considered in Papers V-VI, although not as the main focus of the work.

Heat integration between two processes implies that heat is cascaded between the processes with the aim of achieving total energy utility requirements that are lower than they would be

for two stand-alone processes. Heat integration can also be applied to evaluate how heat can be recovered efficiently within a given process (Paper II).

The process integration alternatives studied in Paper II and applied in Papers III and IV, also considers mass integration. It should be highlighted that mass integration often refers to advanced methods for estimation of re-utilizing residual flows efficiently within a process (see e.g. Klemeš et al. (2018)). In this work, however, mass integration simply implies that residual streams from one process can be utilized as feedstock in another process co-located at the same site, thereby reducing feedstock transportation requirements. If a gasification based LBG plant is integrated at a sawmill site, the residues from the sawmill (bark, saw dust and wood chips) can be used as feedstock to the gasifier.

In Papers II-IV, the heat flows of the integrated process were assumed to be cascaded through an integrated steam cycle in order to co-generate a maximum amount of electricity. In Paper II, a linear optimization tool developed by Morandin et al. (2011) was used to simultaneously maximize the electricity production and the LBG production for a given size of sawmill.

4.4 Value chain model

Paper II quantified the heat and material integration benefits to the performance of the entire value chain. Five different cases were considered for possible sizing of the LBG plant with respect to the sawmill, for two different sawmill sizes. The size of the sawmill determines the quantity of biomass residues that are available as feedstock for the gasifier. However, for some of the LBG plant sizes considered, additional feedstock is required. For these cases, the cost of transporting the feedstock to the plant must be considered. Furthermore, the size of the LBG plant determines the distance the LBG product must be transported.

The results presented focus on the relative differences between key performance indicators for the LBG production process integrated with a sawmill and a reference system consisting of the same generic sawmill (as defined in Anderson and Toffolo (2013)) without LBG production. Figure 8a shows the reference system value chain together with the studied LBG system (Figure 8b), including the relevant system boundaries.

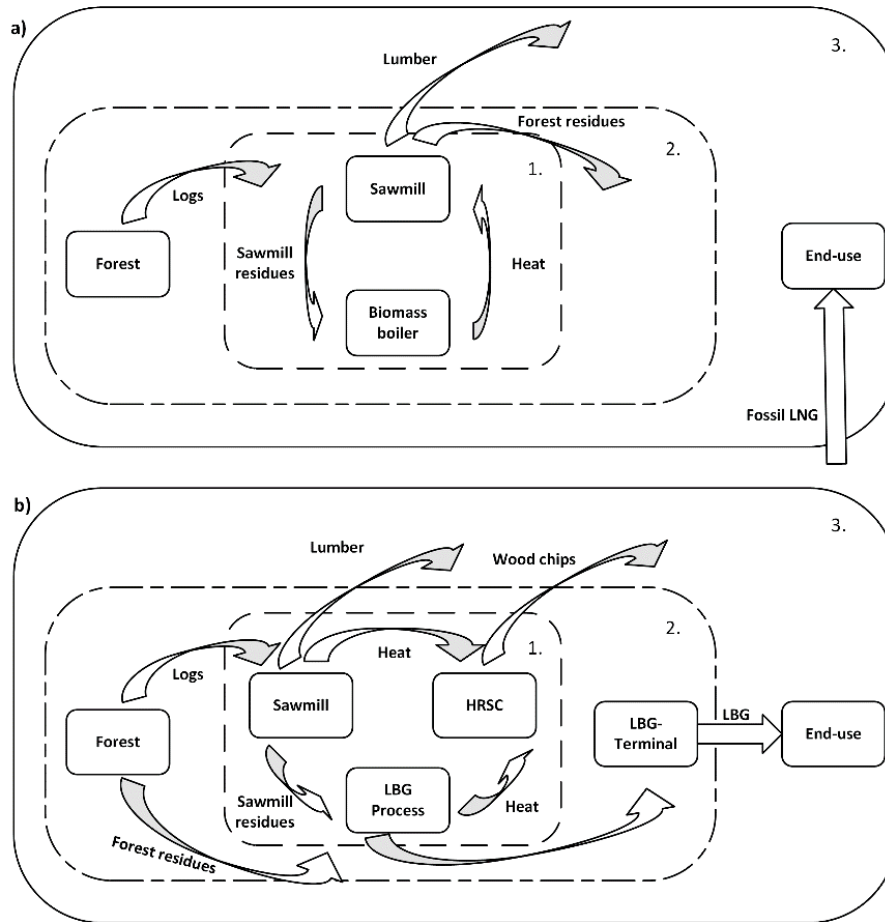

Figure 8. Reference system (a) and Sawmill integrated system (b).

The inner dashed square, marked 1 in Figure 8 b, corresponds to the boundary of the system consisting of an LBG process heat integrated with a sawmill heat system through a HRSC. The integrated process differs from the sawmill in the reference system (Figure 8 a) in which the heating needs are satisfied through combustion of a fraction of the available sawmill residues in a biomass boiler. In the reference system, the sawmill residues not required for heat generation are sold.

To assess the uptake area for biomass, statistics from the Swedish Forest Agency were used (Christiansen, 2014). ArcGis software (esri, 2018) was used to estimate the transportation distance of the finished LBG product. A model relating the electricity co-generated in the HRSC, the uptake area for biomass, and the transportation distance for the product was developed using Microsoft Excel.

4.5 Geographically explicit value chain model

In Papers III and IV, the value chain models developed in Paper II were simplified to allow further investigation using the integer optimization model BeWhere Sweden. The BeWhere Sweden model was originally developed for extensive systems analysis of biofuel and bioenergy systems (see e.g. (Pettersson et al., 2015, Wetterlund et al., 2013)). In previous studies using the BeWhere Sweden modeling framework (see e.g. (Wetterlund et al., 2013, de Jong et al., 2017, Pettersson et al., 2015, Zetterholm et al., 2018)), the analysis focused on biofuels for

transportation. For Paper III, the model was complemented with the option to also provide biomass-based fuels for the ISI.

In BeWhere Sweden all biofuel (LBG) production was assumed to be integrated with existing Swedish sawmills. All sawmill sites were considered as potential hosts for integrated LBG production. The process configurations of the integrated LBG production plants were based on the configurations developed for Paper II. The gasification plants investigated in Paper II were assumed to adopt one of three specific sizes whereas a multitude of possible sizes are possible in the BeWhere Sweden model. To estimate the CAPEX and OPEX of each plant a surrogate modeling approach was applied, achieved through curve fitting of plant capacity to both OPEX and CAPEX.

BeWhere Sweden is a mixed integer linear programming (MILP) model written in GAMS, which uses the CPLEX solver. The model is geographically explicit regarding biomass supply, competing biomass demand, potential new LBG production, transportation infrastructure, and LBG demand. For the work presented in this thesis, the model was run statically for one year at a time and the input price data and level of CO₂-charge was varied for different scenarios. The aim was to study the feasibility of delivering LBG to the ISI and how this is affected by a changing demand from other sectors. This was done in a scenario analysis, where the demand from other sectors was set as a constraint for each scenario and the constraint was relaxed to allow a span of +/- 0.5 TWh. The demand from other sectors was assumed to be satisfied by delivering the required amounts to Swedish LNG terminals and the specific end-use of the product was not considered.

The model objective was to minimize the total system cost to satisfy the LBG demand, while simultaneously satisfying a fixed biomass demand in other sectors, considering costs for energy carriers (including fossil energy carriers), GHG emissions, biomass and LBG transport, as well as investment costs and O&M costs. The model was thus given the option to produce LBG for usage in the ISI if the cost for the produced LBG was lower than the cost for the fossil energy carrier (including CO₂-charge) it replaces.

Continuous decision variables in the model included flow of biomass feedstock from supply to demand sites and flow of LBG product from production sites to LNG terminals and/or ISI sites. The binary variables were choices of location(s) and integration scale(s) for LBG production. The model was constrained regarding the domestic biomass supply, based on technical and economical limitations. The model was specified to allow fixed levels of feedstock import.

4.5.1 Multi-disciplinary framework for cost increase assessment

When introducing large-scale biomass gasification for production of biofuels, the demand for specific grades of biomass changes, which in turn affects their price. The basic idea of Paper IV was to study how the changes in prices affect the economic performance of biomass gasification. For this purpose, a multi-disciplinary framework was applied which connects the BeWhere Sweden model with a partial-equilibrium model of the Swedish forest and biofuel sectors. This framework was first presented in previous work (see Zetterholm et al. (2020)). Figure 9 illustrates the framework which is based on soft-linking of the BeWhere Sweden model

and the partial equilibrium, biomass market model SFSTM II (Carlsson, 2012, Bryngemark, 2019).

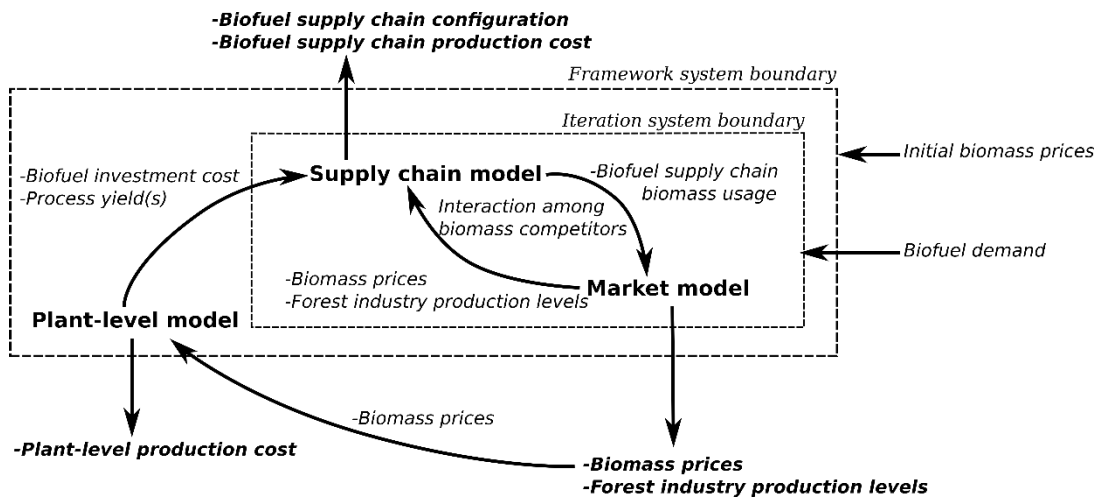

Figure 9. Illustration of the working schedule of the framework applied in Paper IV.

BeWhere Sweden was first run for production of a specific quantity of LBG. The resulting calculated biomass demand was then provided as input to the market model which re-calculates feedstock costs which were used as input data for the next model iteration run in the BeWhere Sweden model. This iterative procedure was continued until biomass prices converge between iterations. Since the BeWhere Sweden and SFSTM II models also account for how biomass is used in other sectors, e.g. pellets production, the price-updates at each iteration entail changes in the type of feedstock that is used to satisfy other system demands, e.g. in the heating sector. The end-result is a set of prices for all biomass grades considered which corresponds to the changes in feedstock demand induced by introducing a new biofuel demand.

4.6 Electricity system model

The gasification models developed for Paper V were simplified in order to include them in the ENODE model. ENODE is a linear programming model that minimizes the cost of investments and dispatch of generation units in an electricity system. A three hourly time resolution of the electricity demand is considered that must be met by electricity generation, under a strict specified CO₂-emission constraint. A single year is modelled adopting a greenfield approach, with assumed values of CO₂ charges for the year 2050. The electricity grid is modelled as a copperplate for a single region without including import and export from surrounding regions, implying that there is no existing power generation in the system, except for hydro power. The model can be adopted to investigate all European electricity regions. Investments and dispatch of the electricity system are optimized according to cost. Fossil resources can be used for power generation but are then charged for the corresponding GHG emissions.

As opposed to the BeWhere Sweden model, ENODE is not an integer model, it is not geographically explicit (although it considers limited geographical regions) and it is necessary to represent the studied technologies generically. For this purpose, two of the LBG plant models developed in Paper V were selected and simplified through linearization, namely configurations

(i) (ii in Paper VI) and (iv) (iii in Paper IV). The LBG production volume was fixed, leaving only the H₂ supply rate to the process as a variable.

Historical re-analysis data was used for modelling of wind and solar power, from the same year as the demand and hydro-inflow profiles. Electricity generation is allowed from renewable sources of biomass, biomethane, wind, solar and hydro together with nuclear power and fossil fuels (with or without carbon capture capacity). Hydrogen is assumed to be produced through electrolysis and can be consumed either by industrial processes or for electricity generation in fuel cells. Electricity can be stored in batteries or used to produce hydrogen which can be used as it is produced, be stored in underground hydrogen storages or in hydrogen tanks. To represent a supply-demand curve, a piece-wise biomass price was used, based on the work by Bryngemark (2019).

Three types of impact related to implementation of LBG production were considered. Firstly, the increased demand for hydrogen for enhancing the biomethane production in configurations (ii) and (iii) (see Section 3.4). Secondly, the competition for available resources of biomass between electricity generation and production of biomethane to be sold to an exogenous market. Thirdly, the gasification and electricity system are bound by the same carbon emissions balance and policy, which implies that negative emissions provided by the gasification plants or biomethane used for electricity generation alters the total costs for the system.

4.7 Scenarios, analysis and performance indicators

This section provides an overview of the input data scenarios as well as the main thermodynamic and economic key performance indicators (KPIs) applied to quantify the results presented in the thesis. For a thorough description of the scenarios, please refer to the papers. Only the KPIs that require a specific mathematical definition are presented.

4.7.1 Scenarios and analysis

Table 3 presents an overview of the scenarios applied in the different papers.

Table 2. Overview of scenarios studied in the different papers. SE is Sweden, IE is Ireland and ES is Spain.

	Paper I	Paper II	Paper III	Paper IV	Paper V	Paper VI
Scenario						
Process configurations	1	5 (times 2)	4	3	4	3
Economic sensitivity	Yes	Yes	Yes	No	No	Yes
CO ₂ charge	-	-	Yes	-	-	2 levels
Energy Price Scenarios	1	1	5	1	1	1
Biofuel policy support	-	-	With and without	-	-	-
Regions	(SE)	SE	SE	SE	-	IE, SE, ES
Biofuel demand	-	-	4 levels	2 levels	-	-

In Paper I, measurement data from three stable measurement periods was used (see Table 1). The gasification model was run using data from these measurement periods and compared with each other. Additionally an extrapolation algorithm (see sub-section 4.2.1) was applied to investigate the performance for operation with dried feedstock, which gives an estimation of how a commercial gasification plant could be expected to perform when operating with bark as feedstock. A single process configuration was considered, and sensitivity analysis was conducted to assess the impact of feedstock cost. Although this study was not performed with a specific geographical scope, all costs were based on Swedish data.

In Paper II, the economic performance was evaluated for five different process configurations, differing regarding the relative size of the gasification plant in relation to the sawmill host (see Section 3.2). Two different sawmill capacities were considered: small (50 000 m³_{sw/a}) and large (500 000 m³_{sw/a}). The impact of increasing important cost parameters was also considered, e.g. feedstock cost and capital recovery factor.

In Paper III, cases 1, 2, 4 and 5 from Paper II (see section 3.2) were further evaluated applying a geographical explicit scope for delivery of LBG to the ISI and other sectors. Five different energy market scenarios were considered, generated using the Energy Price and Carbon Balance tool (ENPAC) (Axelsson and Pettersson, 2014, Harvey and Axelsson, 2010). The ENPAC tool estimates possible future prices of different energy carriers for large end-users in Northern Europe, based on input data from the IEA's World Energy Outlook (International Energy Agency, 2018), and assuming that market prices are determined by the total levelized production cost of marginal production. A CO₂ charge is indirectly considered in the results presented since such a charge is included in the ENPAC tool market models, and the geographical scope is specific to Sweden. However, additional CO₂ charge analysis was also

Methods

performed, increasing the CO₂ charge to the level required to achieve 100% phase-out of fossil fuels in the ISI. Four levels of LBG demand from other sectors (0-12 TWh/a of LBG) and two technology cases, allowing and not allowing the largest gasification configuration (iv, Case 5 in Paper II), were evaluated using energy price scenarios.

In Paper IV, three of the cases from Paper II (1, 4 and 5, named A, B and C in those results) were evaluated using a framework considering changes in biomass feedstock prices when increasing biofuel production (referred to as the *iterative-endogenous* case). These results were compared to the results from only running the BeWhere Sweden model, i.e. not accounting for price changes in feedstock (referred to as the *current-exogenous* case). Two levels of biofuel demand were studied, 4 and 8 TWh/a. The geographical scope of the study was Sweden.

Paper V presents the base results used for further evaluation in Paper VI. In this paper, no geographical scope was applied, and the main purpose was the comparison of different process configurations.

In Paper VI, the analysis was performed for two levels of CO₂ charge (150 resp. 250 EUR/t CO₂) in three different geographical regions: Ireland (IE), electricity price area SE3 in Sweden (SE) and central Spain (ES). The reason for studying the concept in different geographical regions is to capture the impact of differing conditions for renewable electricity generation. Ireland was chosen as the base case owing to its favorable conditions for wind power generation, which in turn creates an electricity price curve profile with high variability. Sweden (price area SE3) and Spain were chosen as reference regions owing to high availability of biomass and good possibilities for variation management through hydropower in the case of the former, and for natural good conditions for solar power production in the latter. Additionally, scenario analysis was performed lowering the cost for electricity storing technologies (e.g. batteries), under higher biomass price conditions and removing the flexible gasification option.

4.7.2 Thermodynamic performance indicators

The thermodynamic KPIs applied in this work are summarized in Table 3. One of the aims of Paper I was to study the performance of the gasification reactor when switching to bark feedstock, under different operating conditions. This was partly quantified using several thermodynamic KPIs, described in equations 1-6 in Table 3 below. In the context of this thesis, it corresponds to answering research question 1 and contributes to answering research question 2.

In Paper V the aim was to quantify the performance of the plant configurations investigated in Paper VI, based on the system energy efficiency (equation 7). The specific results of Paper V relate to performance comparisons of the different process configurations studied and thereby in the context of this thesis it corresponds to answering research question 1 and contributes to answering research question 2.

Table 3. Process efficiency performance indicators

Char gasification	$X_g = \frac{n_{c,rg} - n_{c,v}}{n_{c,ch}}$	(1)
Bed material oxygen transport	$\lambda_{otr} = \frac{n_{otr}}{n_{o,f}}$	(2)
Product gas recirculation	$PG_{rec} = f_{rec} * \frac{\sum_{i=1}^{Gas+PAHs} n_i * LHV_i}{LHV_f}$	(3)
Raw gas efficiency	$\eta_{RG} = \frac{\sum_{i=1}^{Gas+PAHs} n_i * LHV_i}{LHV_f}$	(4)
Cold gas efficiency	$\eta_{CG} = \frac{\sum_{i=1}^{Gas} n_i * LHV_i}{LHV_f}$	(5)
Biomethane efficiency	$\eta_{CH_4} = \frac{n_{CH_4} LHV_{CH_4}}{LHV_f}$	(6)
System energy efficiency	$\eta_{system} = \frac{\sum \dot{m}_p LHV_p + Q_- + E_-}{\sum \dot{m}_f LHV_f + Q_+ + E_+}$	(7)

For a description of the nomenclature, refer to the nomenclature section or the papers.

Oxygen transport, product gas recirculation and char gasification all relate to the performance of the gasification process and are relevant for the performance calculations presented in Paper I. The char gasification, X_g , is defined as the fraction of the char that is gasified in relation to the total char content of the feedstock. This parameter assesses the extent of the biomass conversion based on the mass balance of the gasifier. Char gasification is of particular interest when using bark as feedstock, due to high char content. λ_{otr} characterizes the oxygen transported from the combustion to the gasification reactor compared to the oxygen required for stoichiometric combustion of the feedstock.

Figure 6 shows the system boundaries of the gasification process used for the efficiency indicators considered in Paper I. The efficiencies are used to quantify the conversion of feedstock to raw gas and cold gas. The raw gas efficiency η_{RG} quantifies the conversion of biomass in the gasification reactor and is calculated based on the energy content of the raw gas including all the PAHs and the product gas that is later recirculated. The cold gas efficiency η_{CG} is calculated from the product gas leaving the gasification section (after the carbon beds) and it captures the performance of the whole gasification section. To estimate the feedstock related cost (FRC), it is necessary to first calculate the biomethane efficiency, i.e. the amount of biomethane produced per biomass input (LHV_{daf}), see Equation 6. The system boundary applied for the calculation of η_{CH_4} is also shown in Figure 6. Since only the gasification section is modeled in Paper I, η_{CH_4} is calculated assuming a conversion factor of cold gas to biomethane corresponding to maximum possible methanation.

The system energy efficiency η_{system} (Equation 7), applied in Paper V relates the total energy input (LHV), in terms of biomass feedstock and electricity, to the total output from the process in terms of product and heat.

4.7.3 Economic and system performance indicators

Table 4 shows the different economic KPIs applied in Papers I-V. One of the aims of Paper I was to quantify the economic impact of switching from pellets to bark feedstock, based on the results of the thermodynamic performance indicators presented in sub-section 4.7.1. In the context of this thesis, this refers to research questions 1 and 2. The feedstock related cost (*FRC*) is the main performance indicator (Equation 8), calculated by dividing the feedstock cost by the fuel-to-biomethane conversion efficiency of different feedstock options. It does not include any capital costs or additional operational costs. This indicator includes the income from selling the biomethane from which the operational costs of the process are deducted.

In Paper II, the fuel production cost (*FPC*) (Equation 9) was applied as an economic KPI to estimate the best integration option for the five considered process configurations. In this work, both the capital and operational costs of the process are included and the cost contribution from the different parts of the value-chain can be presented separately. These results contribute mainly to answering research questions 1 and 2.

In Paper III, where the aim was to investigate the possible phase out of fossil fuels for heating purposes in the Swedish ISI, the performance is quantified based on the share of fossil fuels substituted by LBG in the ISI and the system cost of supplying LBG to the ISI and “other sectors”. The former measure is presented in Equation 10 and describes the share of LBG delivered to the ISI as a fraction of the total fuel demand. The latter is described in Equation 11 and is calculated by attributing increases in total system cost to LBG production. These KPIs relate to both research question 1 and 2.

In Paper IV the aim was to compare the economic perspective for biofuel production from gasification of the plant-owner to that of the policy maker. This correlates mainly to research questions 3 and 4. For this purpose, several economic KPIs were applied (Equation 12-14). The *Direct production cost (DPC)* is the cost of biofuel production from the plant-level model. It represents the biofuel selling price necessary for a profitable investment from a plant-owners perspective. The *direct supply cost (DSC)* is the direct supply cost of LBG from the supply chain model, and encompasses all direct costs associated with the LBG production. The *total system supply cost (TSSC)* shows the total LBG supply cost from the supply chain model which includes both the direct costs (e.g. costs directly associated with the biofuel production plants) and the indirect costs (e.g. increased costs for other biomass users). This can be analogous to the perspective of a policymaker which also needs to consider the indirect impact on other biomass using industries from the introduction of large-scale biofuel production.

Paper V considers the operational revenues (*OR*) as economic performance indicator (Equation 15), it does not account for investment costs, only operational costs. The results of Paper V provide the necessary input for the evaluation performed in Paper VI. In Paper VI, several KPIs were applied, including CO₂ emissions, electricity production from different technologies and

electricity price. The combination of these two papers addresses all four of the research questions. Paper V mainly contributes to answering the two first research questions, whereas all research questions are considered in Paper VI.

Table 4. Economic and system performance indicators.

Feedstock related cost	$FRC = \frac{P_{\text{feedstock}}}{\eta_{\text{CH}_4}}$	(8)
Fuel production cost	$FPC = \frac{\text{TPI} \cdot \text{CRF} + \text{O\&M} + I_{\text{fr}} P_{\text{fr}} + I_{\text{tfr}} P_{\text{tfr}} + O_{\text{d}} P_{\text{d}} + (I_{\text{el}} - O_{\text{el}}) P_{\text{el}} - O_{\text{el}} P_{\text{el,cert}} - O_{\text{wc sawmill}} P_{\text{wc}} + O_{\text{BM,ref}} P_{\text{Bmref}}}{O_{\text{LBG}}}$	(9)
Share of fossil fuel replaced with LBG	$\text{LBG share in ISI} = \frac{\text{LBG}_{\text{produced}} - \text{LBG}_{\text{demand,other sectors}}}{\text{Total ISI fossil fuel use}}$	(10)
Supply cost LBG	$\text{LBG}_{\text{supply cost}} = \text{LNG}_{\text{price}} - \frac{(C_{\text{base}} - C_{\text{total}})}{\text{LBG}_{\text{produced}}} + \text{Biofuel}_{\text{support}}$	(11)
Direct production cost	$\text{DPC} = \frac{(\sum (E_i \cdot (P_i + P_{\text{tr},i} \cdot d_{\text{tr},i}))) + I \cdot \text{crf} + \text{O\&M}}{E_{\text{BF}}}$	(12)
Direct supply cost	$\text{DSC} = \frac{(\sum_j (\sum_i (E_{i,j} \cdot (P_i + P_{\text{fix,tr},i} + P_{\text{dep,tr},i} \cdot d_{\text{tr},i}))) + I_j \cdot \text{crf} + \text{O\&M}_j))}{E_{\text{BF,tot}}}$	(13)
Total system supply cost	$\text{TSSC} = \frac{\text{Syscost}_{\text{BF}} - \text{Syscost}_{\text{noBF}}}{E_{\text{BF,tot}}}$	(14)
Operating revenues	$\text{OR} = \frac{P_{\text{biomethane}} O_{\text{biomethane}} - \sum \text{OC}}{O_{\text{biomethane}}}$	(15)

The nomenclature is presented in a separate section and in the corresponding papers.

Methods

Chapter 5

Results & Discussion

This chapter presents an overview of the most significant results from the appended papers.

5.1 Technology level and feedstock integration

In Paper I, the specific aim was to evaluate operation of a DFB gasifier with shredded bark feedstock. The performance was compared to operation with regular wood pellets in terms of operability, efficiency and economic performance. It was possible to continuously operate the plant using bark as sole feedstock throughout the measurement period. The mass and energy balance results are presented in Figure 10 for the best performing data set in terms of cold gas efficiency (see Table 1).

A major operational difference between bark and wood pellets is the influence of char gasification on the raw gas efficiency (η_{RG}). Due to the higher fractions of char and ash in the bark feedstock, less volatiles are converted to raw gas. Hence, the raw gas efficiency is significantly affected by the char gasification. A lower degree of char gasification leads to a raw gas efficiency for bark that is around 5 percentage points lower than the efficiency for pellets. The cold gas efficiency (η_{CG}) values for all bark cases are low compared to pellets. Pellets achieve a cold gas efficiency of approximately 70%, whereas the bark cases achieve cold gas efficiency values in the range of 50-55%. As expected, the cold gas efficiency for bark is strongly affected by the high moisture content, which leads to a significant energy penalty for the feedstock drying. The main consequence of the higher moisture content is increased product gas recirculation.

The higher product gas recirculation explains why the difference in raw gas efficiency is smaller than the difference in cold gas efficiency between the bark cases and pellets. However, the difference in cold gas efficiency between the two feedstocks does not necessarily hold if the bark is dried to the same moisture content as the pellets. The relationship between cold gas and raw gas efficiency is dependent on the quantity of tar in the raw gas and on the product gas recirculation. When the moisture content is lower, the internal heating demand (iHD in Figure 10) of the gasifier is decreased, mainly due to a decrease of heat required for evaporation of the water in the feedstock. A decrease in iHD means that a lower share of product gas is required to the combustor, which increases the cold gas efficiency.

The measurements for the B25 case were used as input data for the extrapolation algorithm, to predict performance for a moisture content of 8%, i.e. the same value as the wood pellets. Figure 10 displays the most important process indicators for case B25 and case B8 in comparison to wood pellets (P8).

Results & Discussion

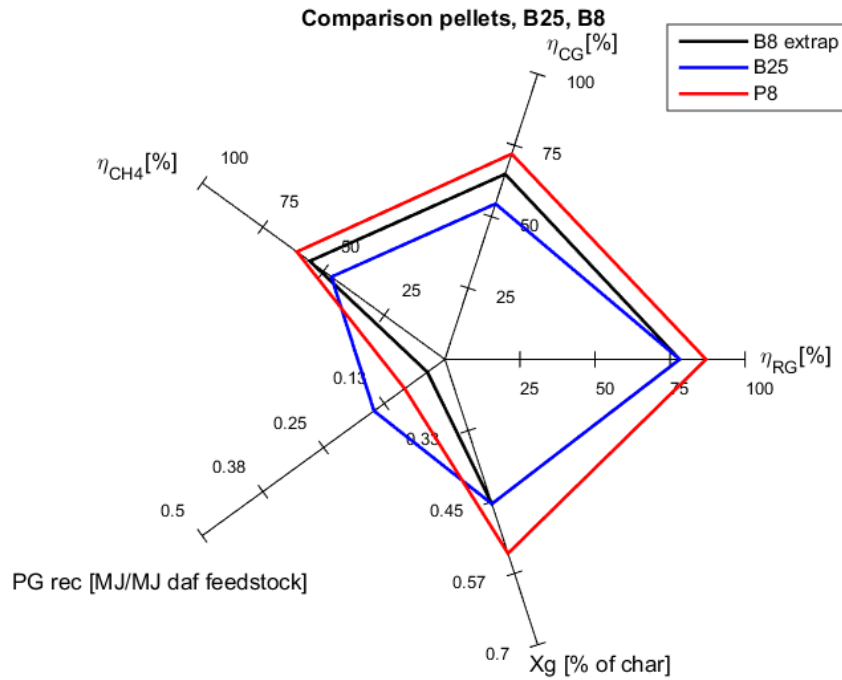

Figure 10. Spider plot presenting the cold gas, raw gas and methane efficiencies together with the char gasification and product gas recirculation for case B25, and the reference wood pellets case (P8). B stands for bark, P for pellets and the number indicates the moisture content on a wet basis, i.e. B25 stands for bark with 25% moisture content.

Figure 10 shows how the shape of the plots of the B25 case results becomes similar to that of the P8 case when the moisture content is lowered (B8 extrap). By lowering the product gas recirculation, it is possible to increase the cold gas efficiency and CH₄ efficiency values for bark operation towards the levels corresponding to operation with wood pellets (65% for 8% m.c. bark, 72% for wood pellets). This also increases the biomethane efficiency (56% for 8% m.c. bark, 61% for wood pellets).

One of the reasons that makes it possible to lower the product gas recirculation more for bark than for wood pellets is the higher levels of tar entering the combustor. However, the main reason is that more char enters the combustor as a result of both higher char content and lower char gasification rate. Since the char gasification is assumed constant for the extrapolated B8 and the original B25 cases, η_{RG} remains at the same level.

The results indicate that the gasifier can achieve a similar biomethane efficiency for different feedstocks if the moisture contents are the same. The FRC (EUR/MWh_{biomethane,LHV}) can therefore be assumed to correlate linearly with the feedstock price (EUR/MWh_{dry,LHV}), depending on the biomethane efficiency (Figure 11a) or moisture content (Figure 11b). The results of the sensitivity analysis of the feedstock price ($\pm 15\%$ with respect to the current price) are shown in Figure 11a. The results were obtained using the original data for bark from case B25 and the results obtained when extrapolating the results of B25 to 8%_{w.b.} moisture content. The feedstock cost is presented per MWh of dry ash-free biomass. A reference figure (Figure 11 b) with

different biomethane efficiencies provides an indication of the potential cost for a commercial-scale, optimized plant.

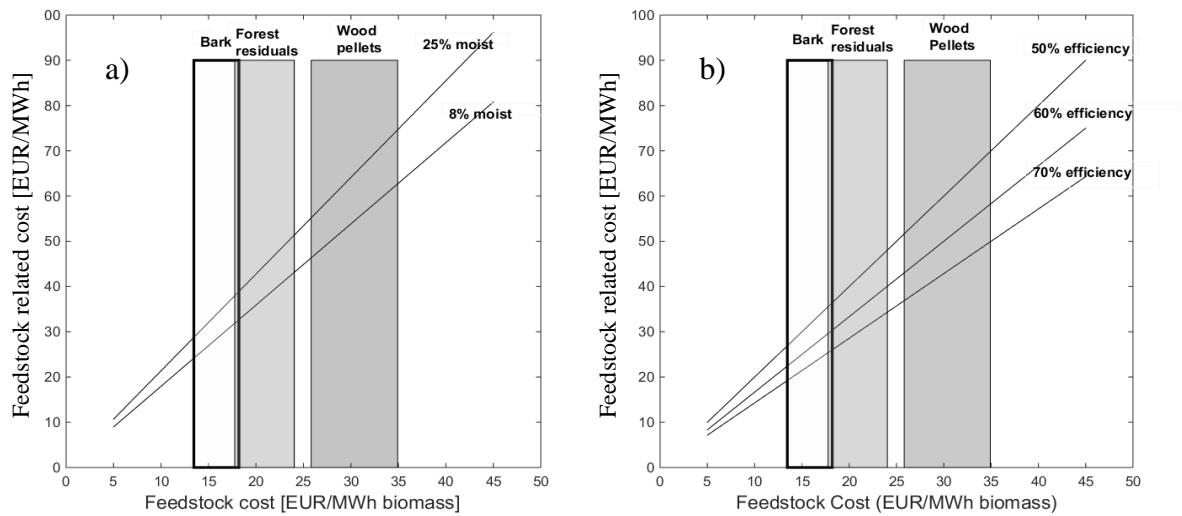

Figure 11. Economic sensitivity analysis. Bars represents feedstock prices with a sensitivity of $\pm 15\%$; lines show the feedstock related cost as a function of feedstock cost for different moisture contents (a) and different biomethane efficiencies (b)

As shown in Figure 11, the cost of the bark feedstock per MWh of biomethane product is lower than that of wood pellets, even if a feedstock with 25%_{w.b.} moisture content is used. Thus, the feedstock-related cost for bark is always lower than for pellets, regardless of the moisture content. The same conclusion can also be reached for operation with forest residues. This is because the price of wood pellets is much higher than the prices of forest residues and bark.

The cost of producing biomethane can be decreased by 13.5-18.3 EUR/MWh biomethane solely by switching feedstock to bark with 25%_{w.b.} moisture content corresponding to an overall decrease of approximately 32%. However, if the feedstock is dried to 8% moisture content, the production cost decreases by an additional 18.1-24.6 EUR/MWh biomethane or 42%. Using dried forest residues results in approximately the same feedstock related cost as using bark with 25% moisture content. The results also show how the cost can be decreased to approximately 23-31 EUR/MWh biomethane, if the efficiency can be increased to 70%, which should be possible for a commercial-scale plant using a feedstock with 8% moisture (Alamia et al., 2017a). For a 100 MW plant, operating at 8000 h/a, an annual net gain of 14.5-19.7 MEUR can be achieved by switching to dried (8%_{w.b.}) shredded bark feedstock compared to using wood pellets.

In summary, the results presented in Paper II clearly show how it is possible to lower biomethane production costs by switching feedstock and more importantly, that it is technically possible. These results are related to the first research question and in combination with the other papers contribute to answering the second research question.

5.2 Process integration

Paper II focused on assessing the value chain consisting of a DFB gasification plant producing liquefied biomethane integrated with a sawmill. The results highlight both economic performance and total GHG emissions, although solely the former is discussed here. For the GHG emission results, the reader is referred to Paper II.

Paper V constitutes the first part in the broader assessment of integrating power-to-gas concepts with a direct blown biomass gasifier that is presented in Paper VI. More specifically, four different process configurations are compared in terms of system energy efficiency and operating revenues.

5.2.1 Sawmill integration energy balances

Five different integration cases were studied in Paper II (see section 3.2). Figure 12 shows the grand composite curve (GCC) for Case 1 (*Available sawmill residues*, see Section 3.2) for a sawmill producing 50 000 m³/a. The values of minimum temperature difference for heat exchanging (ΔT_{\min}) for different stream types are listed in Paper II.

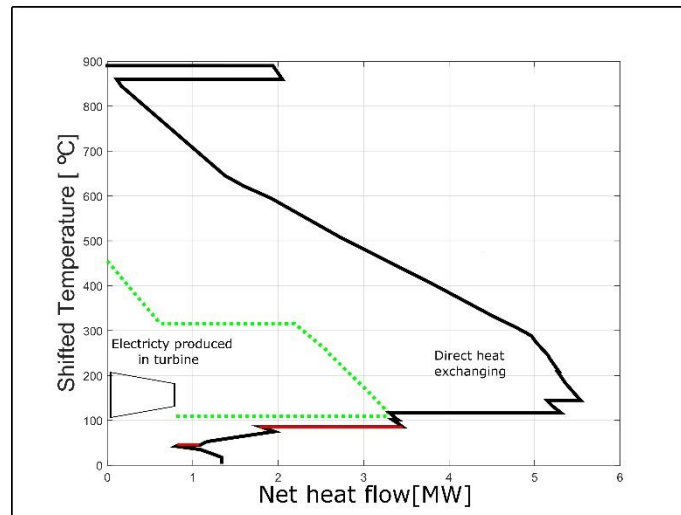

Figure 12. Grand composite curve of Case 1 for the 50 000 m³/a sawmill. The background curve of the LBG process is represented by the black line, the heat requirements of the sawmill are represented by the red lines in the background curve and the green, dotted, foreground curve represents the HRSC.

The horizontal distance indicated by the steam turbine icon between the temperature axis and the end of the foreground curve indicates the target for maximum possible electricity production. The area under the background curve that is not covered by the foreground curve indicates that parts of the heat integration will occur through direct heat exchanging between hot and cold streams.

The curves shown in Figure 12 indicate that the excess heat from the LBG process is sufficient to cover the heating needs of both the LBG process and the sawmill for this case. However, the excess heat from the integrated process is insufficient to fully integrate the HRSC (dotted line). This is because there is not enough surplus heat to raise steam with all available excess heat, and still cover the heating needs of the integrated process.

Results & Discussion

The resulting GCCs of the other four cases are presented in Paper II. When the LBG process is sized according to different criteria, the relative sizes of the heat flows between the sawmill and the LBG process change. A larger LBG process enables a higher degree of integration of the HRSC, increasing the possible electricity generation. However, beyond a certain size, the LBG process becomes so large that a condensing turbine section is required in the steam cycle in order to harness all excess heat released, i.e. more heat is available from the LBG than required by the sawmill.

Table 5 presents the resulting energy flows for each case and for the two sawmill sizes (50 000 and 500 000 m³/a). The different sizing criteria are described in Section 3.2.

Table 5. Energy flows, feedstock transportation distances and total investment costs.

Sawmill size /Case	Biomass from Sawmill [MW]	Imported Forest residues [MW]	Net biomass use [MW]	LBG produced [MW]	LBG produced per net biomass use	Electric Power balance [MW]
50 000 m³/a						
1	14.0	0.0	11.8	9.7	0.82	-0.7
2	7.0	0.0	4.7	3.9	0.83	0.5
3	14.0	10.0	21.8	16.7	0.77	-0.1
4	14.0	6.0	17.8	13.9	0.78	-0.1
5	14.0	706.1	717.8	500.0	0.7	5.9
500 000 m³/a						
1	140.4	0.0	117.9	97.5	0.82	-7
2	69.6	0.0	47.2	38.6	0.83	5.0
3	140.4	99.8	217.7	166.8	0.77	-1
4	140.4	60.4	178.2	139.4	0.78	-1
5	140.4	579.7	697.6	500.0	0.72	3.7

Each case has a flow of imported forest residues/by-products coming from the sawmill and for some of the cases, additional forest residues are imported to the process. The total biomass required is the imported forest residues plus the biomass from the sawmill and the net biomass use is the difference in used biomass compared to the reference sawmill case, which uses enough biomass to cover the sawmill heating needs through a boiler.

The degree of heat recovery is highest for Cases 2 (*Available sawmill residues excluding wood chips*) and 4 (*Sawmill heat demand*). In Case 2, export of a fraction of the biomass residues from the process entails that a part of the available bark and sawdust needs to be combusted to fulfill the heat demand; the heat released if all biomass is gasified is not enough to fulfill the heat demands of the sawmill. By burning parts of the biomass in a boiler, heat is released at a higher temperature, which means that the electricity generation becomes more efficient. Therefore Case 2 results in an excess of electricity generated by the process. For Case 4, the steam cycle is perfectly integrated (see Section 3.3). However, as high temperature heat from a

furnace is not available, less electricity is generated, resulting in a small net electricity deficit for the process. This also results in a higher net biomass use in relation to the LBG produced for this case, as compared to Case 2.

Since the steam cycle integration is not optimal in Case 1, the net power balance is negative. However, even though the power balance is negative, the heat demand of the sawmill is satisfied relatively efficiently, and no resources are used for production of condensing electricity, which results in a high production of LBG per unit of biomass used. Case 3 (*Forest residues uptake area*) also has a net negative power balance. The import of additional feedstock leads to higher electricity production; it also results in a relatively high net biomass use in relation to the amount of LBG produced.

In Case 5 (*Large scale*), the LBG process produces large amounts of excess heat that is used for electricity production through a condensing turbine stage, due to sawmill heat demand mismatch. This means that the net electricity production for this case is positive. However, the positive aspects of the process integration are limited, and the energy efficiency performance is poor, with a significantly higher net biomass use in relation to the produced LBG, at the same time as a lot of excess heat is used for inefficient condensing power generation.

Since all flows are assumed to scale linearly when estimating the energy balances for the different cases, the shapes of the fore- and background curves are the same for all sawmill sizes, except for Case 5. For Case 5 the scale of the LBG process is fixed and thereby the scale relative to the sawmill differs for the two considered sawmill sizes. Thus, the electricity production per net amount of biomass differs between the sawmill sizes in Case 5.

5.2.2 Sawmill integration economic performance

Figure 13 presents the calculated fuel production cost for all cases. “Internal feedstock” denotes the incremental usage of sawmill by-products compared with the reference sawmill case, thereby constituting a cost (or a lost revenue from selling of the by-products). The external feedstock cost is the cost for purchased forest residues.

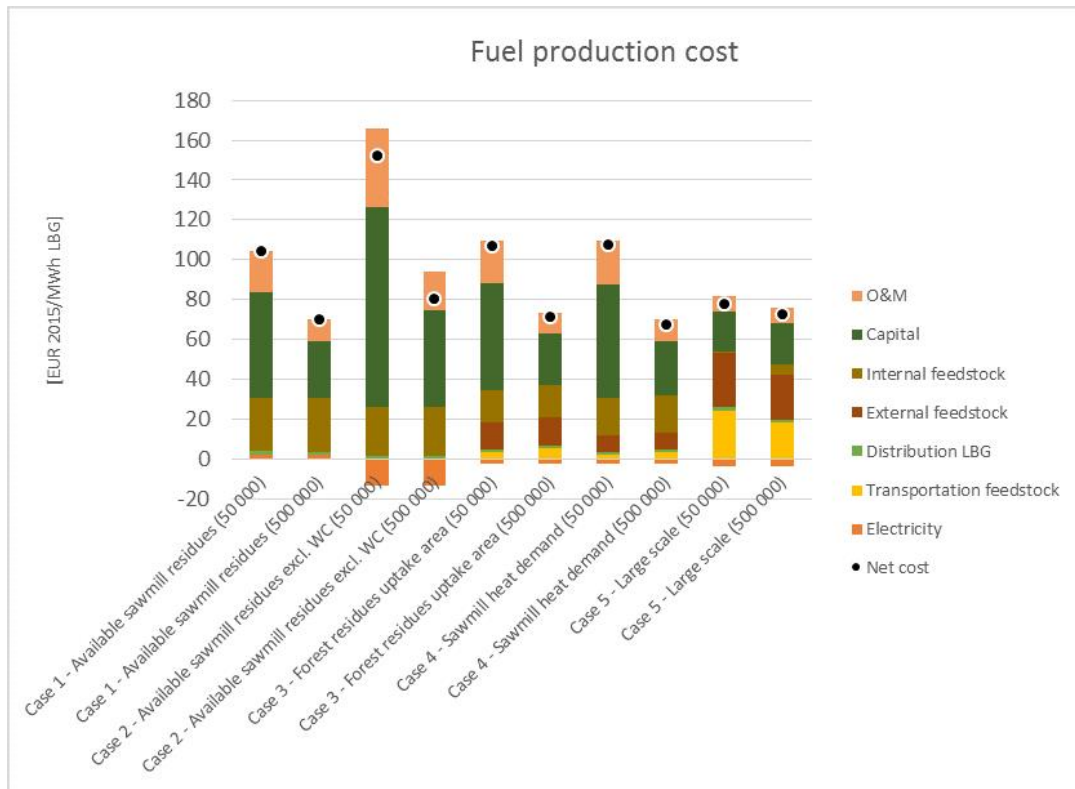

Figure 13. Fuel production cost (FPC) for all cases and the 50 000 and 500 000 m³/a sawmill sizes.

The resulting fuel production cost spans over a range from 68 to 156 EUR/MWh_{LBG}. In general, the plant costs (capital cost and O&M cost) have the largest impact on the economic performance, followed by the total feedstock cost (internal and/or external, depending on case, plus feedstock transportation). The impact of plant costs is most significant for smaller LBG plants (Case 2 – both sawmill sizes, as well as Cases 1, 4 and 3 – small sawmills), while feedstock related costs dominate for larger plants (Case 5 – both sizes, as well as Case 3 and 4 – large mills). The net electricity balance has a limited impact on the FPC.

It is apparent that in economic terms, size matters. Consequently, Case 5 (Large scale) performs best in the small size sawmill, whereas for the largest sawmill, Case 4 (Sawmill heat demand) achieves the lowest FPC and both Cases 1 and 3 perform better than Case 5. Capital cost is not a linear function, contrary to all energy related flows, but decreases non-exponentially per produced unit with increased production (economy of scale). Thus, Cases 1-4 cannot compete for the smallest sawmill size, where the total biofuel production is several orders of magnitude higher for Case 5. The high transportation cost for the feedstock clearly limits the performance of the large-scale case (Case 5), for both sizes. This is also the only case where feedstock transportation is a major contributor to the total FPC, as it constitutes about a third of the total FPC. The lowest FPCs are found for the largest sawmill cases, and for the cases with relatively efficient excess heat usage – heat load matching, i.e. Cases 4, 1 and 3, which achieve relatively similar FPCs, but with partly different cost breakdowns.

Since the specific capital cost decreases with increasing size, at a certain point the increasing cost of transporting the additional required feedstock to the plant will outweigh the benefits of a larger plant. Heat integration also has an impact on the economic performance.

The results of the analysis show clearly that process integration is an important aspect when producing LBG integrated with a sawmill. If the biofuel process is too large in relation to the sawmill, the opportunities for heat recovery are limited, which means that the FPC becomes higher than it needs to be due to high transportation costs for feedstock.

In summary, these results show that through process integration, it is possible to considerably lower biomethane production costs based on biomass gasification. Nonetheless, it is the scale of production that is the most important contribution to production cost through the capital investment required. This implies that just building a large-scale plant might be preferred in many cases, at least from a cost perspective.

5.2.3 Electrolysis integration (power-to-gas concepts)

Paper V constitutes the first part in the larger assessment of integrating power-to-gas concepts with a direct blown biomass gasifier that is presented in Paper VI. The results compare four different process configurations in terms of system energy efficiency and operating revenues.

Three of the four process configurations (configurations 1, 3 and 4) for the power-to-gas evaluations were subjected to sensitivity analysis, varying the amount of H₂ fed to the process. For configuration 2, the H₂ flow is constant at 10 kmol/h, which is the flowrate required to convert all CO₂ in the gas mix. The results for both operating revenues (equation 17) and system energy efficiency (equation 7) are shown in Figure 14.

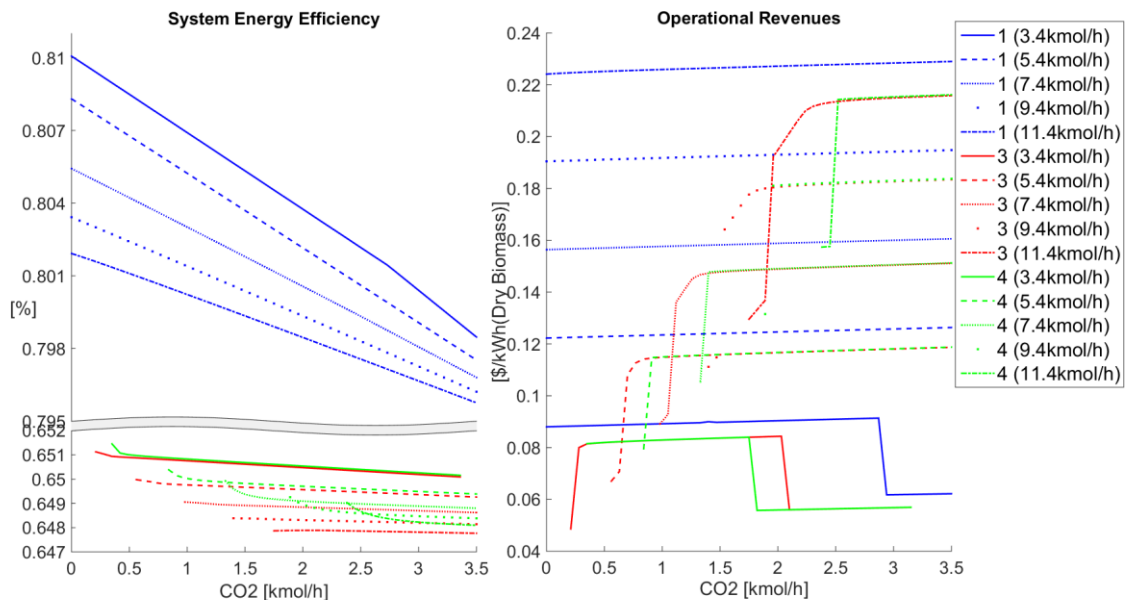

Figure 14. Total system energy efficiency and operating revenues as a function of CO₂ recirculation. The line colors correspondent to different configurations and the line types correspond to the amounts of H₂ feed. The ranges of each curve indicate the cases where the produced gas fulfills the A or B Wobbe index specifications for the Swedish gas grid.

Figure 14 shows that η_{system} decreases with increased H_2 feed and CO_2 recirculation rate. This is due to the conversion losses in the electrolyser, implying that the larger the share of the total energy input that comes from electricity, the lower the system energy efficiency will be.

The process operating revenues increase for all configurations for increasing values of H_2 feed and CO_2 recirculation rate. This indicates that the additional biomethane produced by the increased supply of H_2 outweighs the cost of generating the H_2 . The increase in revenues is essentially linear, except for some rapid increases and decreases. These rapid changes indicate the thresholds for the types of biomethane produced, namely when the model has to change from production of grade A to grade B biomethane. Only configuration (i) has an increase in revenue that can be achieved without CO_2 recirculation, which is because there is already CO_2 present in the incoming gas flow. For configurations 3 and 4, a certain amount of CO_2 must be recirculated to provide the second reactant to the Sabatier reactor.

Sensitivity analysis was not performed for configuration 2, since the H_2 feed to the process is fixed. The system energy efficiency of configuration 2 is 0.801 and the operating revenues are 0.245 \$/kWh_{dry biomass}. Configuration 2 results in the highest revenues and a high system energy efficiency, which is because all CO_2 in the raw gas is converted to CH_4 .

The main value of the results from Paper V relates to the development of the models later incorporated in Paper VI. Nonetheless, the results also highlight the validity of the electrolysis integrated gasification concept and thus contribute to answering research questions 1 and 2.

5.3 Value chain integration

5.3.1 Iron and steel industry

Paper III assesses the potential to phase out fossil fuels used for process heating purposes in the Swedish ISI. The resulting share of fossil fuels phased out is presented in Figure 15, for the different price scenarios (see Paper III or refer to Axelsson and Pettersson (2014)), technology cases, and demand scenarios.

Results & Discussion

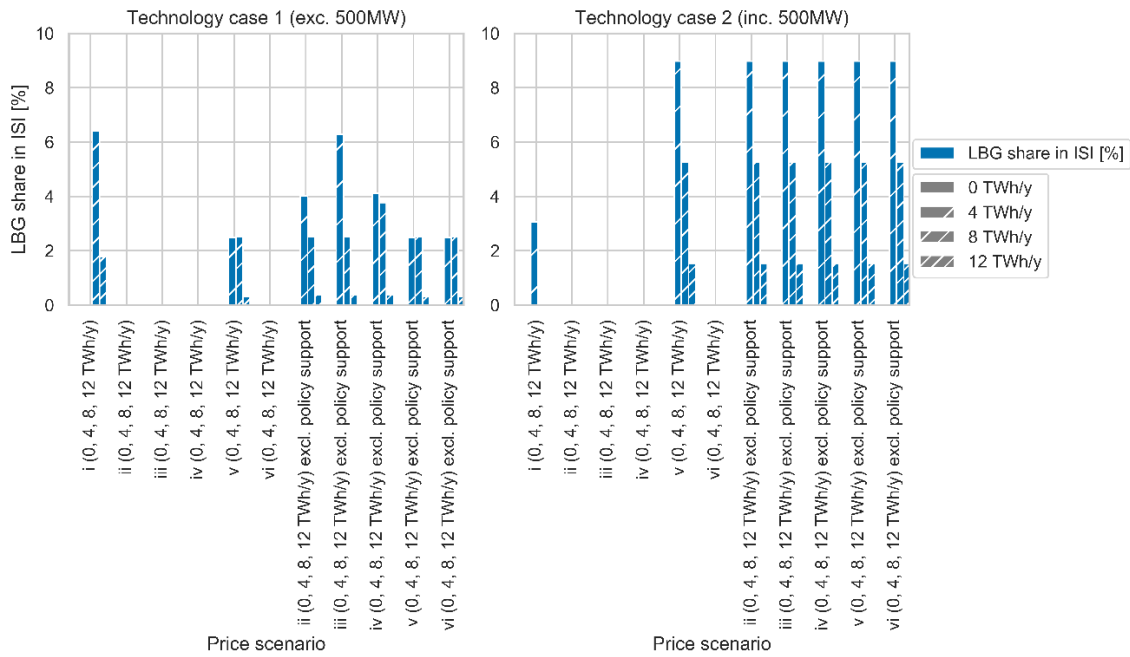

Figure 15. Replaced share of fossil fuels for heating in Swedish iron and steel industry (ISI) for all price scenarios. Left-hand side: technology case 1. Right-hand side technology case 2.

Both *technology case 1* (not including “Case 5 -Large scale” from Paper II, i.e. the 500 MW biomass gasification configuration) and *technology case 2* (including “Case 5 -large” from paper II) result in LBG delivered to the ISI for some scenarios. In both technology cases, only energy price scenarios *i* and *v* result in LBG to the ISI when the policy support is included, regardless of demand from other sectors. Price *scenario i* is the Base Case, with the lowest cost of biomass, whereas *scenario v* is the 2040 scenario with current policy support where the prices of fossil fuels are higher than in any other scenario (excl. CO₂-charge), thus stimulating the system to increase the production of LBG. The reason that there is a difference in how much that is produced between the technology cases, when including policy support, is that when the 500 MW plant size is allowed, it is always preferred due to lower specific CAPEX. This implies that regardless of scenario, a maximum of three LBG plants are constructed for *technology case 2*, leading to escalating transportation costs of delivering to the ISI. Thus, only excess LBG, when the set demand in other sectors has been satisfied, is allocated to the ISI.

For both technology cases, the inclusion of biofuel support (biofuel premium) for LBG as a transportation fuel has a negative effect on the amount of LBG delivered to the ISI, as the ISI was excluded from the targeted biofuel support. This shows that a targeted biofuel support aimed at de-fossilization of the transport sectors risks leading to market distortion, as LBG would then be attributed a higher value for use in transportation than in the ISI. The results here show that with biofuels support included, LBG is only allocated to the ISI when the transport sector market is saturated.

Regardless of price scenario and technology case, substitution of fossil fuels in the ISI is relatively moderate. Delivery to the ISI peaks at a fossil fuel replacement level of approximately 9% when including the 500 MW LBG plant, and at approximately 6% if it is excluded. For most cases, LBG delivered to the ISI peaks for the case when the LBG demand from other

Results & Discussion

sectors is 4 TWh/a, after which it gradually decreases for the 8 and 12 TWh/a cases. For *technology case 1*, several scenarios have a similar usage of LBG in the ISI for both the 4 TWh/a, and 8 TWh/a demand from other sectors. Regardless of price scenario, an LBG demand in other sectors is required for any LBG to be produced for the ISI. Without a demand for LBG from other sectors, a switch to LBG will not be economically justifiable for the ISI; at least not with prevailing or predicted CO₂ charges and energy prices.

If the model is given the opportunity to select 500 MW LBG production plants, they will be favored due to the lower specific CAPEX. One of these plants is sufficient to cover the total ISI fuel need, and five plants would be able to cover both the demand for the ISI and the 12 TWh/a demand from other sectors. Therefore, the system is also less flexible in terms of the number of individual plants built when this option is included. Hence, for this case and from a total system cost perspective, there are more economical limitations related to building additional gasification plants to produce LBG for the steel industry. When excluding the 500 MW option, naturally, the size of the LBG production facilities is significantly decreased. For this case, both the size and geographic position of the sawmills will affect the LBG plant location, contrary to the cases including the 500 MW LBG plant, where only the location of the sawmill will have a noticeable impact if the site is chosen as a host site for LBG production.

Figure 16 shows the system cost of supplying LBG (see Equation 11). The LBG supply cost varies between approximately 70 and 120 EUR/MWh_{LBG, LHV}.

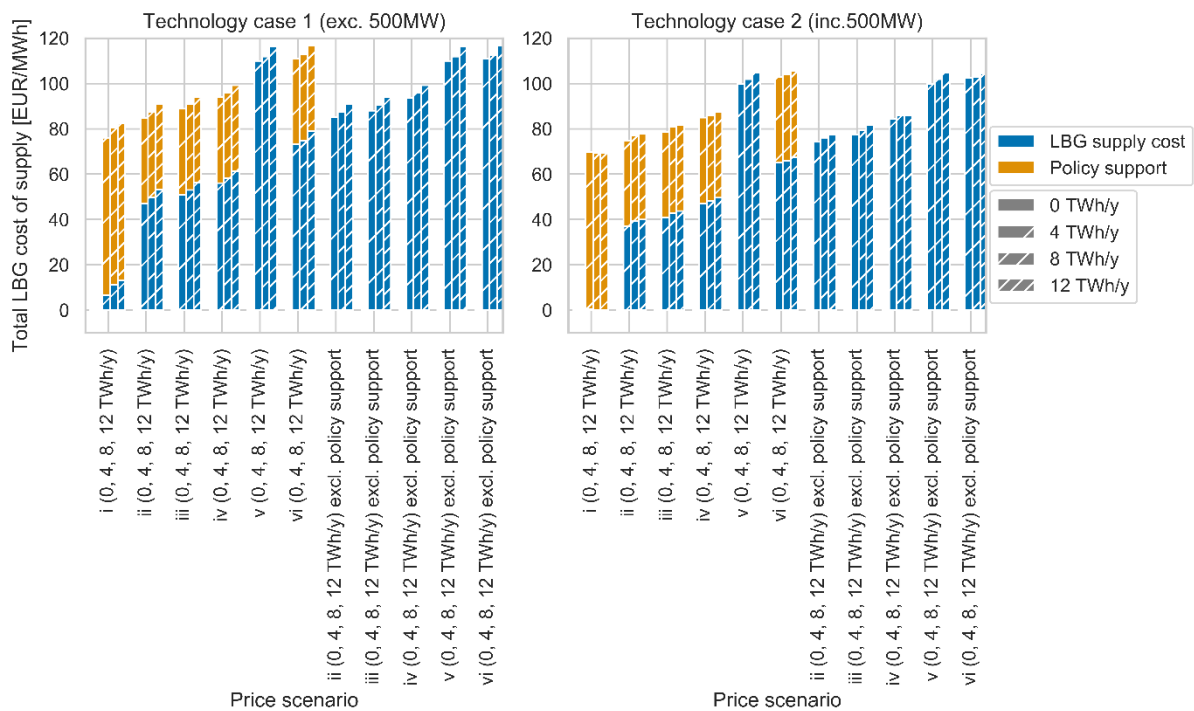

Figure 16. Total system cost of supplying LBG for Technology case 1 (upper) and Technology case 2 (lower).

The LBG supply cost increases with an increased share of LBG production. This result is expected as LBG is more expensive to produce than using fossil fuels; hence, forcing the system to switch to a higher production of LBG through charges or subsidies will naturally increase

the total system costs. For the cases in which the biofuel policy support is excluded, the total system costs are at similar levels. The reason is that similar demands for LBG production are set for both systems and thus the cost of production are similar; the difference is only how the cost is allocated. This also highlights why more is produced to the other sectors than the minimum level when policy support is included. It becomes beneficial, since the policy support is not paid by the system. On the other hand, when the policy support is removed, this incentive disappears. Figure 16 shows that LBG supply costs are higher for *technology case 1*. This highlights what has already been discussed; it is cheaper from a system perspective to invest in the largest-scale plant if that is possible. Comparing Figure 16 to Figure 15 also shows that the lowest LBG supply cost results in the largest shares of LBG supply to the ISI, even though the correlation between LBG delivered to the ISI and the supply cost is nonlinear.

The results presented in the Paper III show that it is the largest gasification plant that is most beneficial. This downplays the importance of sawmill heat integration and somewhat contradicts the results presented in Paper II. However, it should be emphasized that a 500 MW biomass plant is very large by Swedish standards and might not be reasonable; at more moderate production scales, integration still is important. Including the option of producing LBG in very large facilities (500 MW LBG), decreases the LBG supply cost, but the substitution of fossil fuels in the ISI remains largely unaffected.

These results also highlight that at the considered levels of CO₂-charge and biofuel policy support, demand for LBG in other sectors is crucial to achieve any delivery of LBG to the ISI.

5.3.2 Biomass price feedback

In Paper IV, a multi-disciplinary framework was applied to estimate the effects of large-scale introduction of biomass gasification for production of LBG. Figure 17 shows the calculated *direct production cost*, *direct supply cost*, and *total system supply cost* (see equations 12-14) for the different technology configurations, biomass market price models (*current-exogenous*, *iterative-endogenous*), and biofuel (LBG) demand scenarios (4 and 8 TWh/a).

Results & Discussion

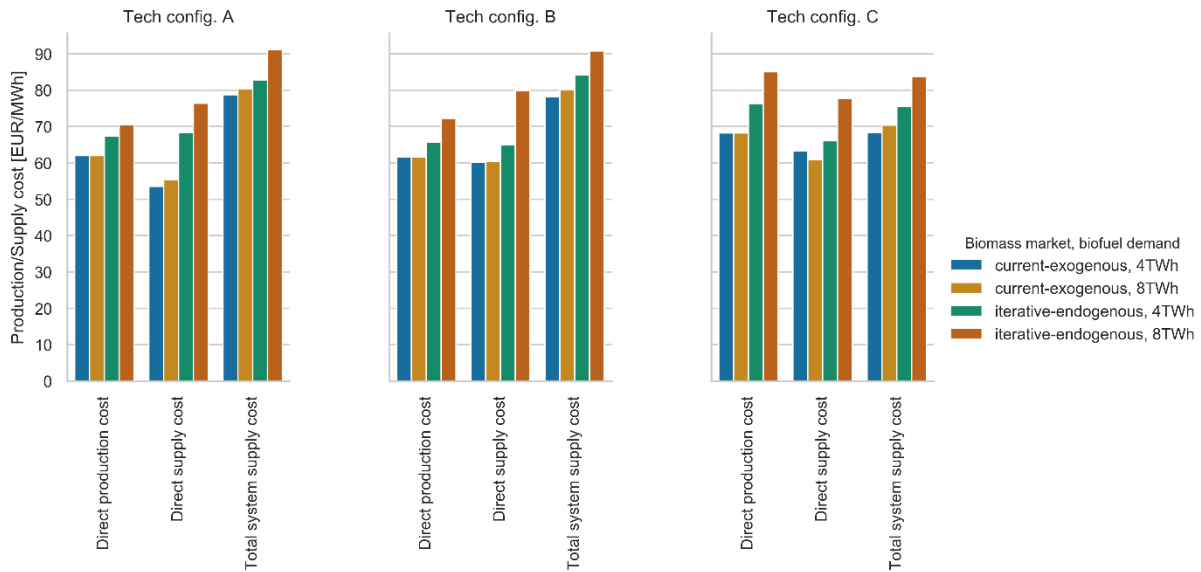

Figure 17. Calculated direct production cost, direct supply cost, and total system supply cost for the different biomass market scenarios, biofuel demand scenarios, and technology configurations. Tech config. A is case 1 in paper II, Tech config. B is case 4 in paper II, Tech config C is case 5 in paper II.

Unsurprisingly, all performance indicators increase as a result of changing from the *current-exogenous* to *iterative-endogenous* biomass market price models. The cost increases are particularly pronounced for the 8 TWh/a biofuel demand scenario. The total system supply cost shows a smaller increase compared with the direct production cost and the direct supply cost when changing from the current-exogenous to the iterative-endogenous biomass market price model. This is a consequence of the total system supply cost incorporating the impact on other biomass users. The change from the current-exogenous to the iterative-endogenous biomass market price model results in a decreased biomass demand in the pellets industry due to decreased pellets production. As the value of the forest industry products in BeWhere Sweden are not included in the total system cost, the reduced biomass demand from the pellets industry lowers the total system cost. This leads to a lower increase in the total system supply cost from the increased biomass price by changing the biomass market price model, compared to the direct production cost, and the direct supply cost.

For the direct production cost and direct supply cost, technology configuration A (LBG plant sized to utilise all available on-site by-products) is affected most by changes to the biomass market in both biofuel demand scenarios. When biomass prices increase, this configuration cannot satisfy its biomass demand with on-site biomass by-products and instead makes use of imported by-products, such as tops and branches, with higher associated transport costs. However, technology configuration A achieves the lowest increase in the total system supply cost, even though there were small differences between the technology configurations for this performance indicator.

The direct production cost measures the biofuel production cost for the plant-owner and was in general highest for configuration C. If the direct production cost shows that a biofuel production technology is profitable from a plant-owners perspective, several investors can be expected to

Results & Discussion

implement the technology. The total system supply cost, which measures biofuel production cost from a policymaker perspective, was consistently lowest for technology configuration C (sized for 500 MW of LBG production), in all biomass market and biofuel demand scenarios.

As the biomethane fuel output for technology configuration C is significantly larger than the other configurations, fewer production plants are needed to satisfy the biofuel demand scenarios. This results in geographically restricted areas with increased biomass demand, thereby reducing the number of other industrial sites affected by an increased biomass transport cost.

Figure 18 shows how implementation of large scale biomethane production impacts the total output for four different types of forest industry sectors.

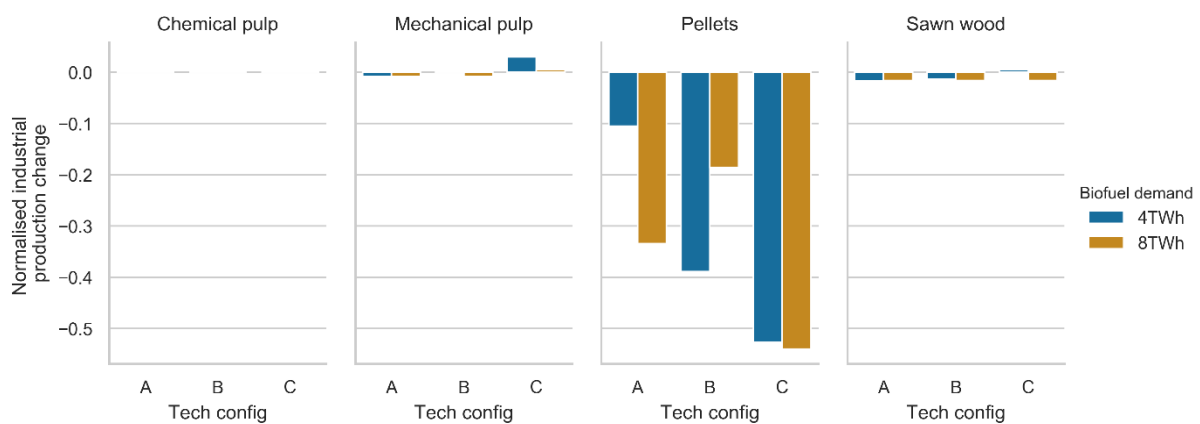

Figure 18. Impact of large-scale biomethane production on the total production output of four major forest industries sectors

The results show that the increased competition for forest feedstock and forestry by-products results in a significant decrease in pellets production, ranging from 10% to 50%, while the other industrial sectors are more or less unaffected. This indicates that policy intervention that mandates biofuel production from biomass feedstock complying with the RED II results in a reallocation of biomass resources from pellets to biofuel production. The benefits from the introduction of the biofuel production thus need to consider the alternative fuels that will replace pellets.

Comparing these results with results from Papers II and III shows that the *total system supply cost* for technology configuration C (case 5 in Papers II and III) is lower than that of the two other configurations, even though they are better heat integrated. This again suggests that size is the dominant factor affecting costs, and that the benefits of better integration for smaller mills cannot compensate for the higher specific investment costs of co-located biomethane production for Swedish sawmills. In contrast to the direct production cost that was, in general, higher for technology configuration C, showing that while the total system supply cost is lower for technology configuration C, a larger share of that cost is carried by the plant-owner.

These results broaden the conclusions by asserting that the cost carried by the plant owner is higher for the largest configuration, making the argument that a smaller, but better integrated plant is the better investment. This also helps to explain the difference in results between Papers II and III. Case 5 (C) did not achieve the best economic results in Paper II yet is consistently shown to perform best in Paper III. This is because the cost for the plant owner (*direct supply cost*) is calculated in Paper II whereas the *total system supply cost* is optimized in Paper III.

Although the results presented in Paper IV provide additional perspective on the results of Papers II and III, it nevertheless mainly relates to research questions 3 and 4. The applied framework shows how by combining methods it is possible to get a more comprehensive result. Furthermore, the results show how both conclusions and absolute results change when accounting for the impact of price changes as a consequence of deployment of biofuel production. It is clear that the introduction of large-scale biofuel production will impact both biomass prices and production at other biomass-consuming industries.

5.3.3 Electricity system

In Paper VI, configurations 1 and 4 from Paper V are further evaluated in the context of future electricity systems characterized by highly volatile production with high charges on CO₂ emissions. The results show that it is profitable for the system to include biomethane production in all three regions investigated. Under the energy market conditions considered (level of CO₂ charge, biomass feedstock and biomethane prices), the simulation results indicate that the system allocates all available biomass for gasification and biomethane production, except for the cases involving the Swedish region SE3 with high biomass availability (above 10 TWh/a) and a CO₂ emission charge of 250 EUR/tonne. This is due to Sweden's good access to variation management strategies (VMS) options through hydropower, which limits the benefit of the CCU option. Figure 19 shows the CO₂ balance of the gasifiers assumed to be implemented in the Irish region for a CO₂ charge of 250 EUR/tonne. The results for the 150 EUR/tonne case are not displayed as the results are almost identical to the 250 EUR/tonne case.

Results & Discussion

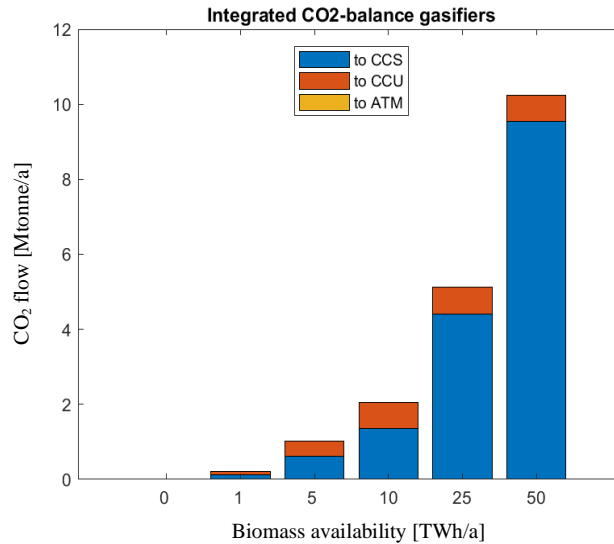

Figure 19. CO₂ balance of the biomethane production plants built in the Irish region for varying levels of biomass availability and a CO₂ charge of 250 EUR/tonne.

Figure 19 shows clearly that the gasification based biomethane plants does not emit any of the generated CO₂ emissions to the atmosphere, regardless of the biomass availability. Figure 19 also shows that most of the CO₂ from the biomethane plant is allocated to long-term storage (CCS) rather than increased biomethane production through CCU. The CO₂ charge has a low impact on the results for the range investigated (i.e. 150-250 EUR/tonne).

Although not shown in Figure 19, configuration 3 (4 in Paper V) performs best in all regions. This shows that it is advantageous to invest in configurations that are flexible with respect to how they use hydrogen (CCU) and that have the possibility to store CO₂ (BECCS). The results also indicate that the CCU option alone is not as beneficial as the flexible option between BECCS and CCU. Both are important but at different times. This is not possible to show with a static price curve and a model that does not account for variations over time. The results are a consequence of varying electricity prices, and thus highlight the value and importance of studying this type of technology and system with a time-resolved electricity price in relation to having a fixed electricity price curve.

From Figure 19 it is also clear that the total quantity of CCU remains constant above approximately 10 TWh/a of biomass availability. When the quantity of gasified biomass increases, the additional CO₂ is allocated to CCS (BECCS). At 1 TWh/a of biomass availability, about 50% of the CO₂ is used for CCU and at 5 TWh/a of biomass availability the corresponding number is around 30%. This means that the flexibility provided by the gasification CCU option is fully harnessed at relatively low levels of biomass availability. As stated previously, within the boundaries of this study, it is more profitable to use biomass for biomethane production rather than for power production, for most of the investigated cases. Conversely, the system allocates most of the generated CO₂ to CCS, rather than increased biomethane production, confirming previous studies that indicate that it may be better to capture biogenic CO₂ in order to achieve net negative emissions rather than to enhance biofuel (electro-fuel) production (see e.g. Lehtveer et al. (2019)).

Results & Discussion

Comparing the flexible gasification concept (configuration iii) to the non-flexible concept (configuration 2, configuration 1 in Paper V) the difference is substantial. For example, running the model with a biomass availability of 25 TWh/a and a CO₂ charge of 150 EUR/tonne for the Irish region (Scenario 4), excluding gasification configuration (iii) lowers the installed biomethane production capacity by 96%. The biomass is instead predominantly used for electricity production in power-plants equipped with CCS capacity (BECCS).

The influence the availability to implement gasification has on the electricity system is shown in Figure 20. For both CO₂ charge cases, the cost of emitting CO₂ is sufficiently high to make the system select to generate more than 90% of the electricity from renewable sources at all levels of biomass availability. However, the type and installed capacity of generation technologies differ between the two cases. Wind turbines deliver most of the electricity at both CO₂ charge levels, but the total electricity production from wind is larger at the higher charge.

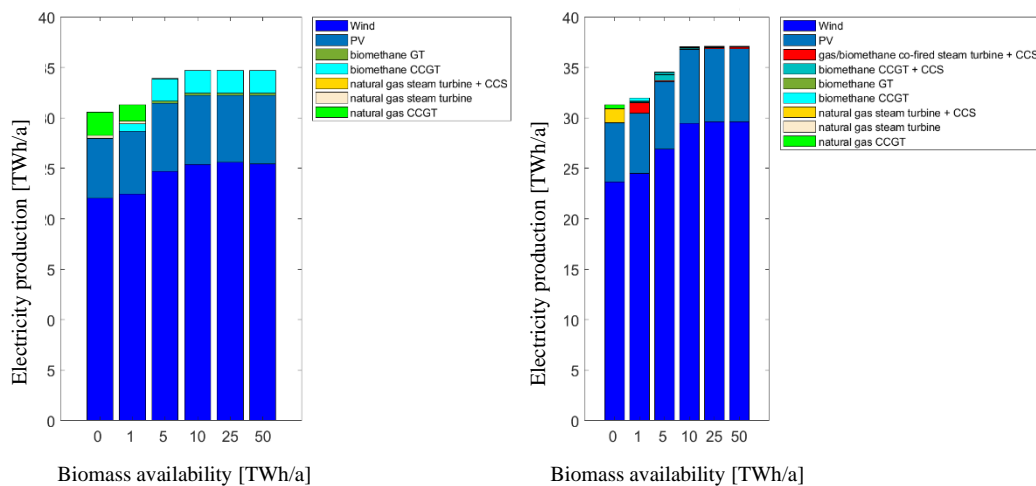

Figure 20. Breakdown of electricity generation per type generation capacity in Ireland. The left graph is at a CO₂ charge of 150 EUR/tonne and the right at 250 EUR/tonne.

For both levels of CO₂ emission charge, most of the remainder of the electricity generation comes from solar PV. For the lower CO₂ emission charge (150 EUR/tonne), the remaining share of electricity generation is produced by natural gas combined cycles and low levels of natural gas steam cycles when the biomass availability is low. When the biomass availability increases, natural gas is gradually replaced by biomethane. The total wind power production also increases, to satisfy the electricity needs to generate the hydrogen required for upgrading CO₂ in the CCU configuration. The driving force for additional gasification is increased biomass availability and thus increased profit from sales of biomethane.

For the higher CO₂ emission charge the remaining electricity is also produced through NG CCGT and NG steam turbines. However, the emission charge is high enough for the system to opt for long-term storage of the CO₂. When the biomass availability is higher, the electricity production at the higher charge almost exclusively comes from wind turbines and solar PV and the production from wind power increases with the biomass availability.

Figure 21 shows how the price curve is shifted for both levels of CO₂ charge when biomass is available for electricity production and/or gasification in Ireland. In the left-hand parts of the figures (i.e. the highest price hours), it can be observed that some of the price hours are shifted downwards when more biomass is available. This is due to a reduced share from combustion-based technologies.

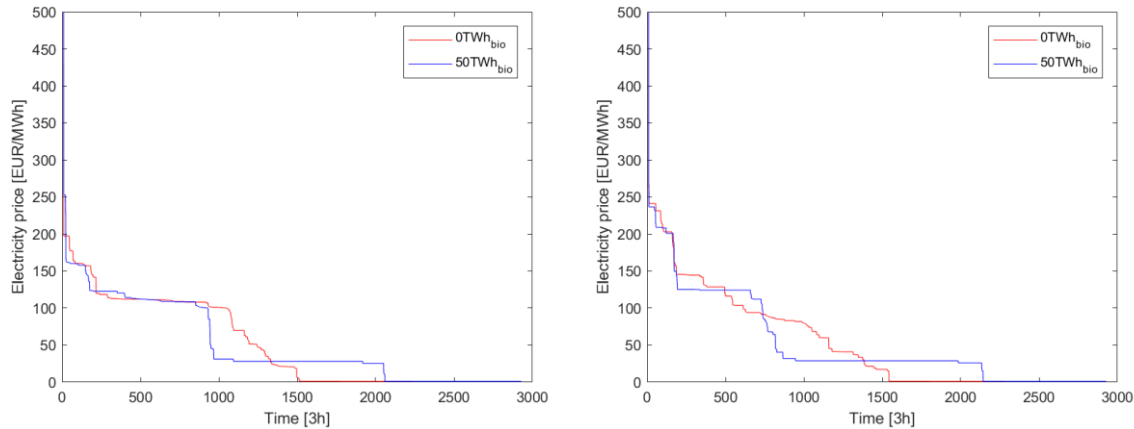

Figure 21. Electricity price for all price hours, sorted in size from left to right. Two levels of biomass availability are shown, 0 TWh/a (red) and 50 TWh/a (blue). In the left figure the lower CO₂ charge (150 EUR/tonne) is applied and in the right figure the higher charge (250 EUR/tonne) is applied.

The two major differences observed when introducing biomass to the system occur for the mid and lowest price hours. During the mid-priced hours (sorted time step 1000-2000), the price curve is more spread out when there is available biomass (i.e. some of the low-priced hours become more expensive). This is due to the actual increase of renewables in the system (low CO₂ charge) and a relative increase of renewables through a phase out of fossil electricity generation (higher CO₂ charge). Towards the right of the figure (i.e. the lowest priced hours), there are significantly fewer hours at an electricity price of zero when there is biomass available. This is due to CCU creating a value for the lowest priced electricity by using it for biomethane production. This is also evident by comparing the left figure (150 EUR/tonne CO₂) to the right (250 EUR/tonne CO₂) where the share of electricity from wind power is higher and the zero-priced hours are even fewer, when biomass is available.

It should be highlighted that 250 EUR/tonne CO₂ is a high CO₂ charge. However, the results show that increasing the CO₂ charge to that level has an impact on how the electricity system is constructed, which is of interest to show. Furthermore, the 250 EUR/tonne CO₂ charge is consistent with the levels deemed necessary to fully phase out fossil gas, presented in Paper III. Nonetheless, increasing the CO₂ charge to this level does not alter the way the gasification concept is operated. The system constructs biomass gasification plants down to a CO₂ charge level of 75 EUR/tonne.

In summary, when biomethane production is investigated accounting for the electricity system perspective, most of the CO₂ is allocated to long-term storage (CCS). However, re-use of CO₂ to further boost biomethane production (CCU) occurs in all cases although to a smaller extent.

Results & Discussion

This is because the income from the biomethane is not the only driving force for CCU. The CCU option also provides an incentive for the system to increase its electricity production from renewables since it acts as a VMS. This incentive occurs above 5 TWh/a of biomass availability, and CCS is always the better option as more biomass becomes available for the system.

The results presented in Paper VI relate to all four research questions. Through them it is possible to conclude that integration of biomass gasification plants with the electricity system can be economically feasible when accounting for the variability of electricity production. Furthermore, the results clearly indicate that the deployment of electricity system integrated gasification has a feedback effect on the electricity system. This effect is positive in that the gasifier CCU option stimulates increased introduction of intermittent, renewable, power generation. Furthermore, this effect was possible to capture by applying tools that account for the time aspect in the simultaneous planning and scheduling of the electricity system that the gasification plants becomes part of.

Results & Discussion

Chapter 6

Conclusions

The overall aim of this thesis was to investigate opportunities to improve the potential for implementation of large-scale biomethane production through gasification of forest biomass, with a focus on different integration aspects.

The first research question was to explore how technical, process and value chain integration aspects could improve the economic feasibility of biomethane production. The results indicate that all the investigated aspects can, at least under specific conditions, contribute to increasing the economic feasibility of biomass gasification for production of biofuels.

Paper I investigated the use of bark as the sole feedstock for a biomethane production plant based on dual fluidized bed gasification technology. The results show that the levelized cost of biomethane production in a commercial scale plant (100 MW_{biomethane}) can be lowered significantly (around 40%) compared to wood pellets as a result of the lower feedstock cost.

Papers II-IV investigated the possibility of heat integrating a biomass gasification plant for production of liquefied biomethane (LBG) at a generic Nordic sawmill site. In Paper II, five different integration cases were investigated, based on the relative sizes of the LBG and sawmill plants. The results show that a heat integrated plant can produce LBG for around 68-82 EUR/MWh which can be compared to an average price for natural gas for industrial users of 34 EUR/MWh in Sweden. Large sawmill sites offer the most promising opportunities and lowest production costs for plants that maximize efficient heat integration through a steam cycle. The results also show how the size of the LBG production plant has the largest impact on fuel production cost, followed by feedstock transportation costs for larger plants.

Paper III applied a geographically explicit value-chain model to further investigate the LBG production concept from Paper II for delivery of renewable heating fuel to the Swedish iron and steel industry (ISI). The results indicate that a high CO₂ charge (above 200 EUR/tonne CO₂) is required for a substantial phaseout of fossil fuels in the ISI. In Paper IV, the impact of large-scale implementation of LBG production on the biomass market was investigated. The results show how the level of policy support required to achieve break-even production of (LBG) integrated with sawmills increases by 13-44% when accounting for the increased biomass price resulting from the increased feedstock demand from the LBG plants. Papers II and III identified different LBG plant configurations as being most economically feasible, with heat integration dominating over size in Paper II, whereas large scale production has a larger effect than heat integration in Paper III. The reason for the differing results is clarified in Paper III, which shows how efficient heat integration is favoured from a plant-owner perspective, whereas plant size is favoured from a system, or policy maker, perspective.

Papers V and VI assessed integration of biomethane production with the electricity grid, by investigating implementation of a carbon capture and utilization (CCU, power-to-gas) concept, in which biogenic CO₂ from the plant is converted to biomethane using hydrogen generated by electrolysis. The biomethane plants were also given the possibility to separate and store the

Conclusions

biogenic CO₂ (BECCS). The results show that it is economically advantageous to construct large-scale, gasification based, biomethane production facilities. It is also clear that integrating the gasification plant has a positive effect for the electricity grid since it constitutes a new power load during periods in which renewable electricity production exceeds demand.

The second research question addressed the type of integration that should be prioritized when deploying large-scale production of biofuels from gasification of forest biomass. The fact that the integration concepts were investigated in different systems and under different assumptions made a straight comparison complex. Nonetheless, some of the conclusions presented in the papers are easily generalized, whereas others are dependent on the development of other aspects of the energy system.

In Paper I, the results show that implementing biomass gasification technology at large scale and operating with bark feedstock that is abundantly available can substantially decrease the biofuel production cost compared to operation with wood pellets. Furthermore, this would create a market for a residual waste biomass feedstock. This is also the concept investigated in this thesis that has the largest direct impact on production costs, regardless of the future policies that are in place to promote biofuel production.

There are also clear synergy effects that can be achieved by large-scale deployment of biomass gasification concepts integrated at existing sawmill sites (Papers II-IV). The scope was limited to Sweden where the forest industry is well developed with multiple potential sites that could be suitable for integration of biomass gasification concepts. Furthermore, Sweden's sawmill industry is very suitable for colocation of biofuel production given the large heat demand for drying of lumber (which creates significant opportunities for heat integration) and existing feedstock handling infrastructure. However, the results of these papers also highlight that from a system perspective, the size of the production plant is in the most important factor that can contribute to decreasing production costs, compared to efficient heat integration.

In Papers V and VI, the results indicate that integration of large-scale biofuel production with the electricity system through CCU (power-to-gas) concepts can be economically feasible. Furthermore, the integration has positive effects for that the electricity system that has new demand for intermittent, renewable generation. It is more advantageous to capture and store biogenic CO₂ from the biofuel production plant (CCS) compared to using the CO₂ as feedstock for further biofuel production (CCU). Nevertheless, in all cases investigated, the relatively small fraction of CO₂ used for CCU increases the value of excess electricity (with a value close to zero) to a level that has considerable impact on the cost-optimal mix of electricity generating technologies. However, there are multiple other industrial development pathways that could harness these opportunities, e.g. hydrogen-based steel production. Future decisions on the development of the electricity system will influence the benefits of integrating gasification technology with the system and hence it is hard to make any general recommendations regarding this integration pathway. However, if deployment of large-scale biofuel production is to become reality, there are large benefits that can be drawn from integration with the electricity system. In that sense, it is important that future studies of the electricity grid consider integration of large-scale biofuel production facilities.

Conclusions

In summary, using a feedstock for which there is currently relatively low demand, such as bark, is the most obvious step towards lowering production cost and this work has contributed to verify that it is technically possible. Efficient heat integration with existing industrial plants, including steam cycles to increase the value of excess heat, can also improve the economic performance of the value chain. For this purpose, sawmills constitute an excellent option from a plant owner-perspective, although larger gasification units, where the integration benefits are not as pronounced as the economies of scale associated with building a large biofuel production plant, are slightly more cost efficient from a system (“policy maker”) perspective. Finally, integration with the electricity system can be a highly interesting opportunity. It is however more dependent on the overall development of the energy system.

The third research question addressed the feedback effects on the energy system that can be expected if implementation of large-scale biomass gasification plants for biofuel production becomes widespread. This question has already been answered concerning integration with the electricity system; it clearly has a positive feedback effect and stimulates the construction of more renewable electricity generation capacity. The more direct effects of large-scale implementation of biomass gasification-based biofuel production on biomass feedstock prices were studied in Paper IV. The results show how large-scale implementation of lignocellulosic-based biorefineries has an impact on prices of all biomass segments which in turn affects production costs. Capturing the possible price increases of biomass feedstock as a result of increased biomass demand also constitutes an additional argument for the kind of efficiency increasing measures that have been studied in this work. Higher resource efficiency lowers the resource demand and hence dampens a feedstock price increase. Additionally, these results again make the case of using bark as feedstock more compelling. Naturally, large-scale use of bark would drive up prices, but it is a currently a feedstock which is in low demand and therefore should have a lower impact on other parts of the biomass economy.

The fourth and final research question concerned the application or combination of methods for determining the feedback effects on the system when implementing large-scale biomass gasification. The results of this work indicate clearly show that such effects can be considerable, and that further work is required in this area. In Paper VI, a dynamic model of the electricity system that considers the geographical diversity of the system was applied. Since the results highlight the importance of the flexible behavior of the gasification unit, it is concluded that a model that accounts for the variability in electricity price and generation are warranted. The gasification plant CCU option also has a clear impact on the electricity system, by significantly affecting the cost-optimal mix of electricity generating technologies. Thereby, the application of the methods used to study this concept has revealed results that would not have been difficult to identify otherwise. These results clearly state the importance of this type of method when studying similar concepts, which is an important conclusion from Paper VI. In Paper IV, feedstock prices affected by changes in demand were compared to static price representation. The results and conclusions emphasize the importance of considering price demand response mechanisms when assessing future energy systems.

The results of this work indicate clearly that integration can enhance the potential for implementation of biofuel production based on gasification technology. However, the main

Conclusions

takeaway is rather that it is possible to improve the performance of biofuel production based on gasification by considering its implementation in combination with or as a complement to existing infrastructure, industry and the ongoing transformation of energy systems towards achieving our common climate targets. Whether it is in relation with existing industry or as a complementing technology that can increase the value of cheap electricity while providing required negative CO₂ emissions at the same time as generating biomethane, the concept of biomass gasification can, when acting as complement, create values extending beyond the intended end-product of the process itself.

Chapter 7

Outlook

The body of work regarding biomass gasification is substantial and ranges from technical investigation of operation with different active bed materials to value chain optimization studies. The concept has been proven in a number of pilot plants based on different types of gasifiers, using different types of feedstock for production of a variety of products. It has also been established in a number of studies that process integration is necessary to increase the overall efficiency of gasification process plants. Although not claiming that there is no need for additional research within these fields, I believe that there are other aspects of biomass gasification where further work is required. As visions of how future energy systems could look like progress, so should visions of how biomass gasification could fit into such systems. Building on the works presented in Papers III, IV and VI is therefore crucial. I strongly believe that this is the case for all types of technologies aspiring to play a part in future sustainable systems; it is unlikely that we will find the one technology pathway which will solve all energy related sustainability issues, at least within a foreseeable future.

One major research challenge for modelling large systems that include feedback loops is to develop models that can be run in reasonable time, without losing too much accuracy. Nonetheless, in my opinion, this type of research is essential to highlight how such effects impact the potential for implementation of biomass gasification. It is, however, important to conduct further studies along the lines of Paper I to verify industrial scale operation with specific feedstocks and will constitute the basis required for further system-oriented studies.

There is also a need for further study of the full value chain for delivery of products from biomass gasification plants for use in a variety of applications. Specifically, such studies should focus on areas where there are limited alternatives to carbon-based fuels, similarly to the case of the ISI studied in Paper III. Examples of such areas included delivery of main or secondary renewable feedstocks to chemical plants or production of jet fuels. To some extent these studies do exist, however, enlarging this knowledge base would allow for better comparison and evaluation of where the limited biomass resource is best used. It is also important to point out that it is not only important to identify where biomass can be used most efficiently, it is also important to investigate where it is needed most.

Another aspect that requires further investigation is integration with the electricity system. In this study a basic analysis of the concept was conducted. However, it is of importance to evaluate large-scale biomass gasification in combination with other types of technologies that could be integrated into the electricity system with the purpose of harnessing opportunities arising from rapid variations of electricity price. In Sweden, the HYBRIT project has been launched to investigate the use of hydrogen produced from renewable electricity as a substitute for coal in blast furnaces for producing steel from iron ore. Implementation of such technologies would require very large quantities of electricity which might affect the opportunities for integrated biomethane production through biomass gasification and power-to-gas concepts integrated with the electricity grid.

Outlook

Finally, a significant share of the discussions regarding climate goals and sustainability has focused on circular economy concepts. Within such systems, a large fraction of products used will still be carbon based, e.g. plastics. Thus, there is an increasing need to focus on recycling. For such purposes, gasification has the potential to play a major part. Research on chemical recycling of plastics through gasification has increased lately (see e.g. (Pissot et al., 2019) but the analysis should be extended. There are many integration aspects related to e.g. location of resources, scale of production, process integration that can be studied using the methods and tools presented in this thesis.

References

- ALAMIA. 2016. Large-Scale Production and Use of Biomethane. PhD thesis, *Chalmers university of Technology*, Gothenburg.
- ALAMIA, A., LARSSON, A., BREITHOLTZ, C. & THUNMAN, H. 2017a. Performance of large-scale biomass gasifiers in a biorefinery, a state-of-the-art reference. *International Journal of Energy Research*, 41, 2001-2019.
- ALAMIA, A., ÒSK GARDARSDÓTTIR, S., LARSSON, A., NORMANN, F. & THUNMAN, H. 2017b. Efficiency Comparison of Large-Scale Standalone, Centralized, and Distributed Thermochemical Biorefineries. *Energy Technology*, 5, 1435-1448.
- ALAMIA, A., THUNMAN, H. & SEEMANN, M. 2016. Process Simulation of Dual Fluidized Bed Gasifiers Using Experimental Data. *Energy and Fuels*, 30, 4017-4033.
- ANDERSEN, L., WEJDLING, A. & NEIDEL, T. L. 2015. *Plastic sorting at recycling centres: Background report*, Nordic Council of Ministers.
- ANDERSON, J. O. & TOFFOLO, A. 2013. Improving energy efficiency of sawmill industrial sites by integration with pellet and CHP plants. *Applied Energy*, 111, 791-800.
- ANDERSSON, J., LUNDGREN, J. & MARKLUND, M. 2014. Methanol production via pressurized entrained flow biomass gasification - Techno-economic comparison of integrated vs. stand-alone production. *Biomass and Bioenergy*, 64, 256-268.
- ARVIDSSON, M., JOHANSSON, E., MORANDIN, M. & HARVEY, S. 2015a. Integration of biomass gasification-based olefins production in a steam cracker plant-global GHG emission balances. *Chemical Engineering Transactions*, 45, 787-792.
- ARVIDSSON, M., MORANDIN, M. & HARVEY, S. 2015b. Biomass gasification-based syngas production for a conventional oxo synthesis plant - Greenhouse gas emission balances and economic evaluation. *Journal of Cleaner Production*, 99, 192-205.
- ASTANEH, M. F. & CHEN, Z. Price volatility in wind dominant electricity markets. 2013. *Eurocon 2013*, IEEE, 770-776.
- AXELSSON, E. & PETTERSSON, K. 2014. Energy price and Carbon Balances Scenarios tool (ENPAC)—a summary of recent updates. Chalmers University of Technology.
- BALAT, M. 2008. Potential importance of hydrogen as a future solution to environmental and transportation problems. *International Journal of Hydrogen Energy*, 33, 4013-4029.
- BAZZANELLA, A., & AUSFELDER, F. 2017. Low carbon energy and feedstock for the European chemical industry. *DECHEMA*, Gesellschaft für Chemische Technik und Biotechnologie eV
- BLOMBERG, M. 2014. Large-Scale Biomass Gasification Plant integrated to a Coal-Fired Boiler. Nov.
- BOKINGE, P., HEYNE, S. & HARVEY, S. 2020. Renewable OME from biomass and electricity—Evaluating carbon footprint and energy performance. *Energy Science and Engineering*, 8, 2587-2598.
- BOLHÀR-NORDENKAMPF, M., BOSCH, K., RAUCH, R., KAISER, S., TREMMEL, H., AICHERNIG, C. & HOFBAUER, H. Scale-up of a 100kWth pilot FICFB-gasifier to a 8 MWth FICFB-gasifier demonstration plant in Güssing (Austria). Proc. 1st International Ukrainian Conference on Biomass For Energy, Kyiv, Ukraine, 2002.
- BRACK, D. 2017a. The Impacts of the Demand for Woody Biomass for Power and Heat on Climate and Forests. *London: Chatham House, the Royal Institute of International Affairs*.
- BRACK, D. 2017b. Woody Biomass for Power and Heat: Impacts on the Global Climate. *Environment, Energy and Resources Department, Chatham House, February*.
- Brown, A., & Le Feuvre, P. (2017). Technology roadmap: Delivering sustainable bioenergy. *International Energy Agency (IEA): Paris, France*, 94.

References

- BROWN, T. R. & BROWN, R. C. 2017. What role for the bioeconomy in an electrified transportation sector? *Biofuels, Bioproducts and Biorefining*, 11, 363-372.
- BRYNGEMARK, E. 2019. Second generation biofuels and the competition for forest raw materials: A partial equilibrium analysis of Sweden. *Forest Policy and Economics*, 109, 102022.
- BRYNOLF, S., TALJEGARD, M., GRAHN, M. & HANSSON, J. 2018. Electrofuels for the transport sector: A review of production costs. *Renewable and Sustainable Energy Reviews*, 81, 1887-1905.
- CARLSSON, M. 2012. *Bioenergy from the Swedish forest sector*, Vol. 2012, No 03.
- CARPENTER, D. L., BAIN, R. L., DAVIS, R. E., DUTTA, A., FEIK, C. J., GASTON, K. R., JABLONSKI, W., PHILLIPS, S. D. & NIMLOS, M. R. 2010. Pilot-scale gasification of corn stover, switchgrass, wheat straw, and wood: 1. Parametric study and comparison with literature. *Industrial and Engineering Chemistry Research*, 49, 1859-1871.
- CELEBI, A. D., SHARMA, S., ENSINAS, A. V. & MARÉCHAL, F. 2019. Next generation cogeneration system for industry – Combined heat and fuel plant using biomass resources. *Chemical Engineering Science*, 204, 59-75.
- CHRISTIANSEN, L. 2014. Skogsstatistisk årsbok 2014. *Skogsstyrelsen*.
- CHUDY, R. P., SJØLIE, H. K., LATTA, G. S. & SOLBERG, B. 2019. Effects on forest products markets of second-generation biofuel production based on biomass from boreal forests: a case study from Norway. *Scandinavian journal of forest research*, 34, 218-227.
- CLAUSEN, L. R., BUTERA, G. & JENSEN, S. H. 2019. Integration of anaerobic digestion with thermal gasification and pressurized solid oxide electrolysis cells for high efficiency bio-SNG production. *Energy*, 188, 116018.
- CONNOLLY, D., MATHIESEN, B. V. & RIDJAN, I. 2014. A comparison between renewable transport fuels that can supplement or replace biofuels in a 100% renewable energy system. *Energy*, 73, 110-125.
- CONSONNI, S., KATOFISKY, R. E. & LARSON, E. D. 2009. A gasification-based biorefinery for the pulp and paper industry. *Chemical Engineering Research and Design*, 87, 1293-1317.
- COWIE, A., BERNDES, G., JUNGIGNER, M. & XIMENES, F. 2017. Response to Chatham House Report “Woody Biomass for Power and Heat: Impacts on the Global Climate”. *IEA Bioenergy: Lismore, Australia*.
- DAIOGLOU, V., DOELMAN, J. C., WICKE, B., FAAIJ, A. & VAN VUUREN, D. P. 2019. Integrated assessment of biomass supply and demand in climate change mitigation scenarios. *Global Environmental Change*, 54, 88-101.
- DE JONG, S., HOEFNAGELS, R., WETTERLUND, E., PETTERSSON, K., FAAIJ, A. & JUNGINGER, M. 2017. Cost optimization of biofuel production—The impact of scale, integration, transport and supply chain configurations. *Applied energy*, 195, 1055-1070.
- DELIN, L., BERGLIN, N., SAMUELSSON, Å., LUNDSTRÖM, A., BACKLUND, B. & SIVARD, Å. 2005. FRAM Final report-Application area: Model mills and system analysis. *Stockholm, Sweden: STFI-Packforsk*.
- EL-HALWAGI, M. M. 2006. Process integration, *Elsevier*.
- ESRI. 2018. *ArcGIS* [Online]. Available: <https://www.arcgis.com/features/index.html> [Accessed 2018-05-03 2018].
- EUROPEAN COMMISSION 2019. "The European Green Deal". Annex to the Communication from the Commission to the European Parliament, the European Council, the Council, the European Economic and Social Committee and the Committee of the Regions.
- EUROPEAN COMMISSION 2018. 2018 - Vision for a long-term EU strategy for reducing green house gas emissions. *In: ENERGY, C. C., ENVIRONMENT (ed.)*.

References

- FLOWER, J. R. & LINNHOFF, B. 1979. Thermodynamic analysis in the design of process networks. *Computers & Chemical Engineering*, 3, 283-291.
- FORTES, P., PEREIRA, R., PEREIRA, A. & SEIXAS, J. 2014. Integrated technological-economic modeling platform for energy and climate policy analysis. *Energy*, 73, 716-730.
- FUELSEUROPE 2020. Clean fuels for all - EU refining industry proposes a potential pathway to climate neutrality by 2050. . In: COOPER, J. (ed.).
- FULTON, L. M., LYND, L. R., KÖRNER, A., GREENE, N. & TONACHEL, L. R. 2015. The need for biofuels as part of a low carbon energy future. *Biofuels, Bioproducts and Biorefining*, 9, 476-483.
- GAS INFRASTRUCTURE EUROPE. 2019. *Small-Scale LNG Map* [Online]. Available: <https://www.gie.eu/index.php/gie-publications/maps-data/gie-sslng-map> [Accessed 2019-08-19 2019].
- GASSNER, M. & MARÉCHAL, F. 2008. Thermo-economic optimisation of the integration of electrolysis in synthetic natural gas production from wood. *Energy*, 33, 189-198.
- GASSNER, M. & MARÉCHAL, F. 2009. Thermo-economic process model for thermochemical production of Synthetic Natural Gas (SNG) from lignocellulosic biomass. *Biomass and Bioenergy*, 33, 1587-1604.
- GNANSOUNOU, E. & DAURIAT, A. 2011. Technoeconomic analysis of lignocellulosic ethanol. *Biofuels*, Academic Press, 123-148.
- GRAHN, M., AZAR, C., LINDGREN, K., BERNDES, G. & GIELEN, D. 2007. Biomass for heat or as transportation fuel? A comparison between two model-based studies. *Biomass and Bioenergy*, 31, 747-758.
- GUNARATHNE, D. S., MELLIN, P., YANG, W., PETTERSSON, M. & LJUNGGREN, R. 2016. Performance of an effectively integrated biomass multi-stage gasification system and a steel industry heat treatment furnace. *Applied Energy*, 170, 353-361.
- GÖRANSSON, L., GOOP, J., ODENBERGER, M. & JOHNSON, F. 2017. Impact of thermal plant cycling on the cost-optimal composition of a regional electricity generation system. *Applied Energy*, 197, 230-240.
- HAGBERG, M. B., PETTERSSON, K. & AHLGREN, E. O. 2016. Bioenergy futures in Sweden—Modeling integration scenarios for biofuel production. *Energy*, 109, 1026-1039.
- HANNULA, I. 2015. Co-production of synthetic fuels and district heat from biomass residues, carbon dioxide and electricity: Performance and cost analysis. *Biomass and Bioenergy*, 74, 26-46.
- HANNULA, I. & KURKELA, E. 2012. A parametric modelling study for pressurised steam/O₂-blown fluidised-bed gasification of wood with catalytic reforming. *Biomass and Bioenergy*, 38, 58-67.
- HARVEY, S. & AXELSSON, E. 2010. Scenarios for assessing profitability and carbon balances of energy investments in industry. *Chalmers University of Technology*, Gothenburg.
- HEYNE, S. & HARVEY, S. Production of synthetic natural gas from biomass-process integrated drying. *22nd International Conference on Efficiency, Cost, Optimization, Simulation and Environmental Impact of Energy Systems*, 2009. 1877-1886.
- HEYNE, S. & HARVEY, S. 2014. Impact of choice of CO₂ separation technology on thermo-economic performance of Bio-SNG production processes. *International Journal of Energy Research*, 38, 299-318.
- HEYNE, S., THUNMAN, H. & HARVEY, S. 2012. Extending existing combined heat and power plants for synthetic natural gas production. *International Journal of Energy Research*, 36, 670-681.

References

- HOFFMAN, J., SIRIMANNE, S. N., ASARIOTIS, R., ASSAF, M., BENAMARA, H., FUGAZZA, M., PREMTI, A., RODRÍGUEZ, L., UGAZ, P., WELLER, M. & YOUSSEF, F. 2017., *Review of Maritime Transport 2017.*, United Nations conference on trade and development.
- HOKKANEN, H., AHLNÄS, T., ALAKURTTI, S., DEMIDOVA, N., FUCHS, J., IZOTOV, D., KLEEBERG, H., KOSKIMIES, S., LANGAT, M. & LYNCH, J. 2012. ForestSpeCs findings on byproducts of forest industry: could bark be more valuable than timber? *NWBC 2012*, 56-59.
- HOLMGREN, K. M., BERNTSSON, T., ANDERSSON, E. & RYDBERG, T. 2012. System aspects of biomass gasification with methanol synthesis - Process concepts and energy analysis. *Energy*, 45, 817-828.
- HOLMGREN., BERNTSSON., E., A. & T., R. 2015. Comparison of integration options for gasification-based biofuel production systems - economic and greenhouse gas emission implications *Energy*, 111, 272-294.
- HOSSEINI, S. A. & SHAH, N. 2011. Multi-scale process and supply chain modelling: from lignocellulosic feedstock to process and products. *Interface focus*, 1(2), 255-262.
- HOURLADE, J.-C., JACCARD, M., BATAILLE, C. & GHERSI, F. 2006. Hybrid modeling: new answers to old challenges introduction to the special issue of the energy journal. *The Energy Journal Special Issue#2*.
- HRBEK, J. 2019. Status report on thermal gasification of biomass and waste (IEA Bioenergy Task 33 special report)
- HUBER, G. W., IBORRA, S. & CORMA, A. 2006. Synthesis of transportation fuels from biomass: Chemistry, catalysts, and engineering. *Chemical Reviews*, 106, 4044-4098.
- HUENTELER, J., ANADON, L. D., LEE, H. & SANTEN, N. 2014. Commercializing second-generation biofuels. *Harvard College: Cambridge, MA, USA*.
- IEA 2020. Outlook for biogas and biomethane: Prospects for organic growth. *IEA, Paris* <https://www.iea.org/reports/outlook-for-biogas-and-biomethane-prospects-for-organic-growth>
- IEA 2018. *World Energy Outlook*.
- JAFRI, Y., WETTERLUND, E., ANHEDEN, M., KULANDER, I., HÅKANSSON, Å. & FURUSJÖ, E. 2019. Multi-aspect evaluation of integrated forest-based biofuel production pathways: Part 2. economics, GHG emissions, technology maturity and production potentials. *Energy*, 172, 1312-1328.
- JOHANSSON, M. T. 2013. Bio-synthetic natural gas as fuel in steel industry reheating furnaces - A case study of economic performance and effects on global CO₂ emissions. *Energy*, 57, 699-708.
- JOHANSSON, M. T. 2016. Effects on global CO₂ emissions when substituting LPG with bio-SNG as fuel in steel industry reheating furnaces—the impact of different perspectives on CO₂ assessment. *Energy Efficiency*, 9, 1437-1445.
- JÅSTAD, E. O., BOLKESJØ, T. F., TRØMBORG, E. & RØRSTAD, P. K. 2019. Large-scale forest-based biofuel production in the Nordic forest sector: Effects on the economics of forestry and forest industries. *Energy conversion and management*, 184, 374-388.
- KALLIO, A. M. I., CHUDY, R. & SOLBERG, B. 2018. Prospects for producing liquid wood-based biofuels and impacts in the wood using sectors in Europe. *Biomass and Bioenergy*, 108, 415-425.
- KAN, X., HEDENUS, F. & REICHENBERG, L. 2020. The cost of a future low-carbon electricity system without nuclear power for Sweden. *Energy*, 195. 117015
- KEMP, I. C. 2011. Pinch analysis and process integration: a user guide on process integration for the efficient use of energy, *Butterworth-Heinemann*.

References

- KLEMEŠ, J. J., VARBANOV, P. S., WALMSLEY, T. G. & JIA, X. 2018. New directions in the implementation of Pinch Methodology (PM). *Renewable and Sustainable Energy Reviews*, 98, 439-468.
- KROOK-RIEKKOLA, A., BERG, C., AHLGREN, E. O. & SÖDERHOLM, P. 2017. Challenges in top-down and bottom-up soft-linking: Lessons from linking a Swedish energy system model with a CGE model. *Energy*, 141, 803-817.
- KURKELA, E., KURKELA, M. & HILTUNEN, I. 2016. Steam-oxygen gasification of forest residues and bark followed by hot gas filtration and catalytic reforming of tars: Results of an extended time test. *Fuel Processing Technology*, 141, 148-158.
- LANDÄLV, I., WALDHEIM, L., VAN DEN HEUVEL, E. & KALLIGEROS, S. 2017. Building Up the Future Cost of Biofuel. *Brussels: European Commission, Sub Group on Advanced Biofuels*.
- LEHTVEER, M., BRYNOLF, S. & GRAHN, M. 2019. What Future for Electrofuels in Transport? Analysis of Cost Competitiveness in Global Climate Mitigation. *Environmental science & technology*, 53, 1690-1697.
- LOVIO, R. & KIVIMAA, P. 2012. Comparing Alternative Path Creation Frameworks in the Context of Emerging Biofuel Fields in the Netherlands, Sweden and Finland. *European Planning Studies*, 20, 773-790.
- LUND, P. D., LINDGREN, J., MIKKOLA, J. & SALPAKARI, J. 2015. Review of energy system flexibility measures to enable high levels of variable renewable electricity. *Renewable and Sustainable Energy Reviews*, 45, 785-807.
- MA, C., CARLBORG, M., HEDMAN, H., WENNEBRO, J., WEILAND, F., WIINIKKA, H., BACKMAN, R. & OHMAN, M. 2016. Ash formation in pilot-scale pressurized entrained-flow gasification of bark and a bark/peat mixture. *Energy & Fuels*, 30, 10543-10554.
- MAFAKHERI, F. & NASIRI, F. 2014. Modeling of biomass-to-energy supply chain operations: Applications, challenges and research directions. *Energy policy*, 67, 116-126.
- MARTINEZ-ANIDO, C. B., BRINKMAN, G. & HODGE, B.-M. 2016. The impact of wind power on electricity prices. *Renewable Energy*, 94, 474-487.
- MASSON-DELMOTTE, V., ZHAI, P., PÖRTNER, H.-O., ROBERTS, D., SKEA, J., SHUKLA, P. R., PIRANI, A., MOUFOUMA-OKIA, W., PÉAN, C. & PIDCOCK, R. 2018. Global warming of 1.5 C. *An IPCC Special Report on the impacts of global warming of*, 1.
- MATHIESEN, B. V., LUND, H., CONNOLLY, D., WENZEL, H., OSTERGAARD, P. A., MÖLLER, B., NIELSEN, S., RIDJAN, I., KARNOE, P., SPERLING, K. & HVELPLUND, F. K. 2015. Smart Energy Systems for coherent 100% renewable energy and transport solutions. *Applied Energy*, 145, 139-154.
- MESFUN, S., SANCHEZ, D. L., LEDUC, S., WETTERLUND, E., LUNDGREN, J., BIBERACHER, M. & KRAXNER, F. 2017. Power-to-gas and power-to-liquid for managing renewable electricity intermittency in the Alpine Region. *Renewable Energy*, 107, 361-372.
- MOHSENI, F., MAGNUSSON, M., GÖRLING, M. & ALVFORS, P. 2012. Biogas from renewable electricity - Increasing a climate neutral fuel supply. *Applied Energy*, 90, 11-16.
- MORANDIN, M., TOFFOLO, A., LAZZARETTO, A., MARÉCHAL, F., ENSINAS, A. V. & NEBRA, S. A. 2011. Synthesis and parameter optimization of a combined sugar and ethanol production process integrated with a CHP system. *Energy*, 36, 3675-3690.
- MOSSBERG, J., SÖDERHOLM, P., HELLSMARK, H. & NORDQVIST, S. 2018. Crossing the biorefinery valley of death? Actor roles and networks in overcoming barriers to a

References

- sustainability transition. *Environmental Innovation and Societal Transitions*, 27, 83-101.
- MUSTAPHA, W. F., BOLKESJØ, T. F., MARTINSEN, T. & TRØMBORG, E. 2017. Techno-economic comparison of promising biofuel conversion pathways in a Nordic context—Effects of feedstock costs and technology learning. *Energy Conversion and Management*, 149, 368-380.
- MUSTAPHA, W. F., KIRKERUD, J. G., BOLKESJØ, T. F. & TRØMBORG, E. 2019. Large-scale forest-based biofuels production: Impacts on the Nordic energy sector. *Energy conversion and management*, 187, 93-102.
- NÄYHÄ, A. & PESONEN, H.-L. 2014. Strategic change in the forest industry towards the biorefining business. *Technological Forecasting and Social Change*, 81, 259-271.
- PALAHÍ, M., HETEMÄKI, L. & POTOČNIK, J. 2020. Bioeconomy: the missing link to connect the dots in the EU Green Deal. *European Forest Institute* [Online]. Available from: <https://blog.efi.int/bioeconomy-the-missing-link-to-connect-the-dots-in-the-eu-green-deal/> [Accessed 2020-03-20 2020].
- PECK, P., GRÖNKVIST, S., HANSSON, J., LÖNNQVIST, T. & VOYTENKO, Y. 2016. Systemic Constraints and Drivers for Production of Forest-Derived Transport Biofuels in Sweden—Part A: Report. *Göteborg, Sweden: f3-The Swedish Knowledge Centre for Renewable Transportation Fuels*.
- PETTERSSON, K., GÅVERUD, H. & GÖRLING, M. 2019. Well-to-wheel costs for forest-based biofuels. *Göteborg, Sweden: f3-The Swedish Knowledge Center for Renewable Transportation Fuels*.
- PETTERSSON, K., WETTERLUND, E., ATHANASSIADIS, D., LUNDMARK, R., EHN, C., LUNDGREN, J. & BERGLIN, N. 2015. Integration of next-generation biofuel production in the Swedish forest industry - A geographically explicit approach. *Applied Energy*, 154, 317-332.
- PFEIFER, C., KOPPATZ, S. & HOFBAUER, H. 2011. Steam gasification of various feedstocks at a dual fluidised bed gasifier: Impacts of operation conditions and bed materials. *Biomass Conversion and Biorefinery*, 1, 39-53.
- PISSOT, S., BERDUGO VILCHES, T., MARIC, J., CAÑETE VELA, I., THUNMAN, H. & SEEMANN, M. 2019. Thermochemical Recycling of Automotive Shredder Residue by Chemical-Looping Gasification Using the Generated Ash as Oxygen Carrier. *Energy and Fuels*, 33, 11552-11566.
- ROSENFELD, D. C., BÖHM, H., LINDORFER, J. & LEHNER, M. 2020. Scenario analysis of implementing a power-to-gas and biomass gasification system in an integrated steel plant: A techno-economic and environmental study. *Renewable Energy*, 147, 1511-1524.
- SCHLERETH, D. 2015. *Kinetic and Reactor Modeling for the Methanation of Carbon Dioxide*. PhD thesis, Technische Universität München, München. I.
- SWEDISH ENVIRONMENT AND AGRICULTURE COMMITTEE 2017. A climate policy framework for Sweden (Ett klimatpolitiskt ramverk för Sverige).
- TAMMA, P., SCHAART, E. & GURZU, A. 2019. Europe's Green Deal plan unveiled. *Politico*.
- THE ROYAL SWEDISH ACADEMY OF ENGINEERING SCIENCES (IVA) 2019. This is how Swedish industry reaches the climate targets (Så klarar svenska industri klimatmålen).
- THE SWEDISH ENERGY AGENCY. 2017. Reduction duty (Reduktionsplikt) [Online]. Available: <http://www.energimyndigheten.se/fornybart/hallbarhetskriterier/reduktionsplikt/> [Accessed 2018-04-23 2018].

References

- THE SWEDISH ENERGY AGENCY. 2019. 100 percent renewable electricity Report 2 - Scenarios, routs and challenges (100 procent förnybar el - Scenarier, vägval och utmaningar). *Energimyndigheten*
- THE SWEDISH GOVERNMENT 2016. Sänkt skatt på biodrivmedel [Online]. Available: <https://www.regeringen.se/pressmeddelanden/2016/03/sankt-skatt-pa-biodrivmedel/> [Accessed 2020-05-20].
- THUNMAN, H., GUSTAVSSON, C., LARSSON, A., GUNNARSSON, I. & TENGBERG, F. 2019. Economic assessment of advanced biofuel production via gasification using cost data from the GoBiGas plant. *Energy Science & Engineering*, 7, 217-229.
- THUNMAN, H., SEEMANN, M., BERDUGO VILCHES, T., MARIC, J., PALLARES, D., STRÖM, H., KNUTSSON, P., LARSSON, A., BREITHOLTZ, C. & SANTOS, O. 2018. Advanced biofuel production via gasification – lessons learned from 200 man-years of research activity with Chalmers’ research gasifier and the GoBiGas demonstration Plant. *Energy Science and Engineering*, 6, 6-34.
- TOCK, L., GASSNER, M. & MARÉCHAL, F. 2010. Thermochemical production of liquid fuels from biomass: Thermo-economic modeling, process design and process integration analysis. *Biomass and Bioenergy*, 34, 1838-1854.
- TORGNYSSON KLEMME, B., MOSSBERG, J., FURUSJÖ, E., SCHNÜRER, A., KÄLLSÄTER, D., BJERDÉN, C., ÅKESSON, F., VIKKULA, M., PETTERSSON, P., LAGERHOLM, J., WILLÉN, P., BORRING, P., ÖRJES, J., JOHANSSON, M., CLAEISSON, M., SVAHN, A., HÖIJER, N., KARRO, K. & TRAN, J. 2019. "Sweden should invest heavily in biofuels" (Sverige bör satsa stort på biodrivmedel). *Svenska Dagbladet*.
- TROY, N., DENNY, E. & O'MALLEY, M. 2010. Base-load cycling on a system with significant wind penetration. *IEEE Transactions on Power Systems*, 25, 1088-1097.
- TSIROPOULOS, I., HOEFNAGELS, R., DE JONG, S., VAN DEN BROEK, M., PATEL, M. & FAAIJ, A. 2018. Emerging bioeconomy sectors in energy systems modeling– Integrated systems analysis of electricity, heat, road transport, aviation, and chemicals: a case study for the Netherlands. *Biofuels, Bioproducts and Biorefining*, 12, 665-693.
- U.S. DEPARTMENT OF ENERGY. 2019. *Alternative Fuels Data Center* [Online]. Available: https://afdc.energy.gov/fuels/natural_gas_benefits.html [Accessed 2019-12-05].
- VOGT, C., MONAI, M., KRAMER, G. J. & WECKHUYSSEN, B. M. 2019. The renaissance of the Sabatier reaction and its applications on Earth and in space. *Nature Catalysis*, 2, 188-197.
- WADSBORN, R., BERGLIN, N. & RICHARDS, T. 2007. Konvertering av mesaugnar från olje-till biobränsleledning–drifterfarenheter och modellering. *Värmeforsk, Stockholm*.
- WALDHEIM, L. 2015. IEA Biomass Agreement Task 33 Country Report Sweden 2015.
- WEILAND, F., WIINIKKA, H., HEDMAN, H., MARKLUND, M. & GEBART, R. 2012. Pressurized entrained flow gasification of biomass powder–initial results from pilot plant experiments. *NWBC 2012*, 136.
- WETTERLUND, E., PETTERSSON, K., MOSSBERG, J., THORÉN, J., HOFFSTEDT, C., VON SCHENCK, A., BERGLIN, N., LUNDMARK, R., LUNDGREN, J. & LEDUC, S. 2013. Optimal localisation of next generation biofuel production in Sweden. *f3 The Swedish Knowledge Centre for Renewable Transportation Fuels and Foundation, Sweden*. Available at www.f3centere.se.
- WILK, V., KITZLER, H., KOPPATZ, S., PFEIFER, C. & HOFBAUER, H. 2011. Gasification of waste wood and bark in a dual fluidized bed steam gasifier. *Biomass Conversion and Biorefinery*, 1, 91-97.

- WOO, C. K., HOROWITZ, I., MOORE, J. & PACHECO, A. 2011. The impact of wind generation on the electricity spot-market price level and variance: The Texas experience. *Energy Policy*, 39, 3939-3944.
- YUE, D., YOU, F. & SNYDER, S. W. 2014. Biomass-to-bioenergy and biofuel supply chain optimization: overview, key issues and challenges. *Computers & Chemical Engineering*, 66, 36-56.
- ZAMBONI, A., SHAH, N. & BEZZO, F. 2009. Spatially explicit static model for the strategic design of future bioethanol production systems. 1. Cost minimization. *Energy & fuels*, 23, 5121-5133.
- ZETTERHOLM, J., BRYNGEMARK, E., AHLSTRÖM, J., SÖDERHOLM, P., HARVEY, S. & WETTERLUND, E. 2020. Economic evaluation of large-scale biorefinery deployment: A framework integrating dynamic biomass market and techno-economic models. *Sustainability (Switzerland)*, 12.
- ZETTERHOLM, J., PETTERSSON, K., LEDUC, S., MESFUN, S., LUNDGREN, J. & WETTERLUND, E. 2018. Resource efficiency or economy of scale: Biorefinery supply chain configurations for co-gasification of black liquor and pyrolysis liquids. *Applied Energy*, 230, 912-924.
- ZHAO, X., BROWN, T. R. & TYNER, W. E. 2015. Stochastic techno-economic evaluation of cellulosic biofuel pathways. *Bioresource technology*, 198, 755-763.

Acknowledgements

When reflecting on my time as a PhD student, I realize that I owe my gratitude to many people, both for their direct support in my work, but even more for their encouragement. Simon, thank you for always taking the time to give feedback whenever I seek it and for your great input to my research. Your guidance has kept this project together. My deepest thanks to Karin for seeing potential in me and for leading me in the right direction in the beginning of the project. Without your continuous support and encouragement, this would have been a much rougher journey. Elisabeth, thank you for always setting time aside to provide perspective when I need it. You continuously lifted me up and encouraged and challenged me. Stavros, thank you for always answering my questions and leaving me with new ones. Your curiosity and drive certainly hold a standard that all researchers should strive for. Henrik thank you for the help with my second paper and for always leaving the door open to discuss any idea or reflection. My last cooperation with Viktor was very rewarding, thank you for fruitful discussions, sometimes about work, but mainly about life and politics. Alberto, thank you for your friendship and your patience while working with the stressed-out version of me. I would also like to thank Lisa, Anton and Claes for the fruitful cooperation.

I would like to thank the Swedish Energy Agency for founding my research project. At this point it is clear which the best FOES-15 group is, and I thank Elina and Jonas for their cooperation in the winning team. Thank you also for all the none-work related discussions and for all the good times.

Thank you to all colleagues, old and new, for creating such a good working atmosphere at both IEST and ET. I would also like to extend a special thanks to my office friends Sofie and Gulnara for putting up with me regardless of my mood switches and the fact that I never remember to water the plants.

At stressful times it is important to remember the good aspects of life and for that there's no better help than friends. Andreas, Pontus, Oscar, Olle and Johan thank you for your friendship, for being there and for all the memories. Lina and Viktor, thank you for all the lunches and endless discussions that helps in keeping mind off from work. My old hockey friends, Martin, Joel, Hallberg, Sebben, Hedlund, Henke och Nicke, thank you for the good times!

A special thanks also to Freddie King, for setting my Friday mood for the past 5 years.

Most importantly, I am thankful to my family for always being there and for all the love. My sisters, Jeanette and Marie, with families, thank you for always being supportive and encouraging. Fredrik, my brother, you are the most warm-hearted person I know, thank you for your humor and kindness. To my mother, your fierce encouragement gives me the strength to carry on when things are tough. To my late father, without your tirelessness in answering questions and never-ending support this would not have happened. This truly is for you.

Finally, my deepest gratitude to my strong, intelligent and beautiful fiancé Hanna. It is you that lift me up in the morning and make me believe that things are possible. I love you.

Johan Ahlström, October, 2020

