



## **Robustness of the HFMI techniques and the effect of weld quality on the fatigue life improvement of welded joints**

Downloaded from: <https://research.chalmers.se>, 2021-08-31 16:53 UTC

Citation for the original published paper (version of record):

Aldén, R., Barsoum, Z., Vouristo, T. et al (2020)

Robustness of the HFMI techniques and the effect of weld quality on the fatigue life improvement of welded joints

Welding in the World, Le Soudage Dans Le Monde, 64(11): 1947-1956

<http://dx.doi.org/10.1007/s40194-020-00974-4>

N.B. When citing this work, cite the original published paper.



# Robustness of the HFMI techniques and the effect of weld quality on the fatigue life improvement of welded joints

R. Aldén<sup>1</sup> · Z. Barsoum<sup>2</sup> · T. Vouristo<sup>1</sup> · M. Al-Emrani<sup>3</sup>

Received: 5 October 2019 / Accepted: 28 July 2020  
© The Author(s) 2020

## Abstract

Robustness of HFMI treatment in different weld qualities according to ISO 5817 was studied, and fatigue testing of the treated samples was carried out in order to investigate the effect of the weld quality prior treatment. The results show that HFMI-treated welds with weld quality level D shows fatigue life improvements that fall within the IIW recommendations for HFMI. No significant influence from the HFMI operator or HFMI equipment on the fatigue life was found. However, the scatter in fatigue testing results varied with HFMI operator and indicated that different HFMI operators could produce consistent treatment results. A considerable effect on fatigue life from HFMI tool radius was found, where the 2-mm tool radius showed considerably greater fatigue life compared with the 1.5-mm tool radius. According to IIW (Marquis and Barsoum 2016), for steel grade  $S_Y = 700$  MPa, the fatigue strength recommendation is FAT 160 ( $m = 5$ ) for transverse stiffener-welded joints with as-welded quality B according to ISO 5817 (ISO/TC 44/SC 10 2011), prior to treatment. It can be observed in the current study that fatigue-tested HFMI-treated welded joints, welded with weld quality D, are in good agreement with the IIW recommendations.

**Keywords** Welded joints · Fatigue · HFMI · Improvement techniques · Weld quality

## 1 Introduction

High-frequency mechanical impact (HFMI) has emerged as a reliable, effective, and user-friendly method for post-weld fatigue strength improvement technique for welded structures. In 2016, IIW published recommendation for HFMI treatment for improving fatigue strength of welded joints [1]. These recommendations give detailed guidelines on procedure, quality control, and fatigue strength improvement for a large range of structural steels, 235–950 MPa in yield strength, with approximately 12.5% increase in fatigue strength for each 200-MPa increase in yield strength. The beneficial effect is mainly because of the impacted energy per indentation. The impacted

material is highly plastically deformed causing changes in the material microstructure and the local geometry as well as high compressive residual stresses, in the close region of the yield stress of the material.

In 2013, IIW published a collective recommendation for improving the fatigue strength of welded joints sensitive for weld toe cracking [2]. This gives detailed guidelines for procedures; quality assurance of treatment; and expected fatigue strength improvement for burr grinding, TIG dressing, and hammer and needle peening. However, recent studies have showed that these fatigue strength enhancements are conservative and higher fatigue strength can be claimed for a successful treatment, particularly for hammer peening and TIG dressing [3–5].

Khurshid et al. [6] studied the behaviour of the compressive residual stresses induced by HFMI treatment under cyclic loading and constant and variable amplitude loading, for different steel grades. They observed that the compressive residual stresses are stable with minor relaxation throughout the fatigue life, where overloads contributed mostly to the relaxation.

Leitner et al. [7] developed FE and analytical models to study the stability of compressive residual stresses under cyclic loading of welded joints. The models were validated with measurements, and it was concluded that the cyclic stability of the

---

Recommended for publication by Commission XIII - Fatigue of Welded Components and Structures

---

✉ Z. Barsoum  
zuheir@kth.se

<sup>1</sup> SWERIM, Kista, Sweden

<sup>2</sup> KTH Royal Institute of Technology, Stockholm, Sweden

<sup>3</sup> Chalmers University of Technology, Göteborg, Sweden

compressive residual stress occurs in the very first cycles and is stable thereafter. Leitner et al. [8] studied the possibilities of using HFMI as a rehabilitation technique of pre-fatigued welded structures. If the HFMI treatment is applied without previous grinding and re-welding of the weld toe, a maximum crack size in depth of 0.5 mm acts as conservative proposal for mild steel joints; the rehabilitation by HFMI leads to an improvement in fatigue strength both in the finite-life and high-cycle fatigue region. Yekta et al. [9] studied the effect of quality control parameters for HFMI treatment of welds and their effect on the fatigue performance and concluded that regardless of the treatment condition (over/under treatment), a significant fatigue strength improvement could be observed.

The IIW HFMI recommendations [1] suggest that the weld before HFMI treatment meets the acceptance limits of quality B, highest weld quality level, in ISO 5817 [10]. In production, the weld sometimes does not reach the highest weld quality level B due to a natural variation in the welding process, material, position etc. [11]. This will result in areas with lower weld quality such as weld quality levels C or D. It is not fully investigated if the HFMI treatment is effective for lower weld qualities, e.g. C and D, and similar increase in the fatigue strength can be claimed as proposed in the HFMI recommendations.

The current study focusses on robustness of post-weld treatment HFMI to increase the fatigue strength of welded structures. Different operators and equipment were used to study the robustness. Transverse stiffener–welded joints were produced in different weld qualities according to ISO 5817, HFMI-treated and fatigue-tested in order to investigate the effect of the weld quality prior treatment. Finite element stress analysis of the 3D measured local weld geometries was carried to study the effect of different imperfections and weld qualities. The highlights from this current study can be summarised as follows:

- The robustness of HFMI treatment (tools/machine, operation time, etc.) of transverse stiffener–welded joints is systematically studied in order to observe any significant effect of treatment parameters on the fatigue strength.
- Observation of possible fatigue life improvement of HFMI-treated transverse stiffener–welded joints welded with lower weld quality (D, according to ISO 5817).
- Development of finite element analysis (FEA) procedure for stress analysis of laser scanning measured welded profiles.

## 2 Experimental setup

### 2.1 Material and sample geometry

The material used when welding the transverse stiffener joints was SSAB 700 MC Plus. Material thicknesses were 10 mm in

the base plate and 6 mm in the standing stiffener. Sample geometry used was transverse stiffener joints, as shown in Fig. 1a. Filler material used for the welding trials was Böhler EMK8 and shielding gas AGA Mison 18 with a Motoman HP20-B00 robot that was equipped with an EWM PHOENIX 521 PROGRESS PULSE coldArc power source. Samples welded for HFMI treatment and as-welded reference of weld class D were welded with 29 V, 14.2-m/min wire feed, and 72-cm/min travel speed. As-welded samples of weld class B were welded with 29 V, 8.9-m/min wire feed, and 40-cm/min travel speed. All samples were welded with a contact tube distance of 15 mm.

Welded samples were welded as 495-mm-long cruciform panels with four welds per panel. Welded panels were first tack-welded with three 25-mm tack welds as shown in Fig. 1b. In order to avoid welding start/stop effects and influence from tack welds, three 50-mm pieces were removed and scrapped as shown by the dashed lines in Fig. 1b. Subsequent to welding and removal of tack-welded areas, the welded panels were cut into 40-mm-wide specimens. The 40-mm samples were then HFMI-treated and fatigue-tested. In order to keep deformations due to welding to a minimum, the welding order is of great importance. The welding order chosen in this project is shown in Fig. 1c. Prior to fatigue testing, the specimens were measured for angular misalignment.

### 2.2 HFMI treatment

The test matrix was constructed with two different weld quality levels B and D according to ISO 5817. Two series without post-weld treatment (PWT) were selected as references to be compared with the four series of HFMI-treated welds. Weld quality D was chosen for HFMI-treated welds, and not weld quality C, due to inferior in fatigue strength and more difficult to treat with HFMI due to toe angle geometry and thus the limited access as shown in Fig. 2. Hence, if a gain in fatigue life can be shown for weld quality D through HFMI, then it is assumed that a gain in fatigue life can be achieved for weld quality C by HFMI as well. The welded samples with weld class D were welded so that the weld toe angle would be the limiting factor with respect to ISO 5817. The reason for this was that it is thought to be troublesome to perform HFMI treatment on welds with small weld toe angle with a potential risk of cracking in the weld toe, as shown by Marquis and Barsoum [1] and in Fig. 2. Five batches were produced with weld quality D. Four batches out of these were HFMI-treated prior fatigue testing. One batch was produced with weld quality B, without any HFMI treatment. Each batch consisted of 6 different specimens.

The post-weld treatment was performed with three different HFMI machines and four different HFMI tools. Two machines and two tools are of the same type and manufacturer but with different operators performing the HFMI treatment.

**Fig. 1** **a** Geometry of welded samples and dimensions. **b** Schematic view of tack welds and scrapped parts of the specimens. **c** Schematic view of welding order and direction

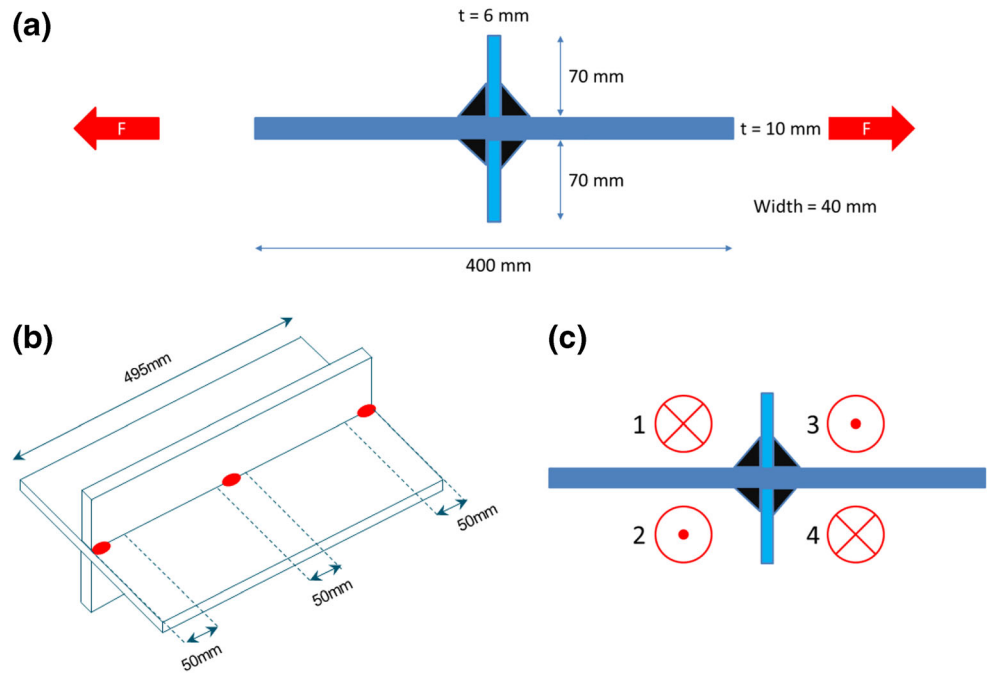

The HFMI machines and tools of the same type and manufacturer used in the project are named HFMI machines 1 and 2, HFMI tools 1, 2, 3, and 4 as shown in Table 1. The purpose of using HFMI equipment of the same type with different operators is to see the influence of the operator performing the HFMI treatment.

During the HFMI treatment, data was collected about how the treatment was performed. The data collected during HFMI treatment were time (travel speed) and number of operations (number of treatments passes of the same weld joint). The purpose here is to gain knowledge if it is beneficial to treat welds multiple times with HFMI.

### 2.3 Digital weld quality measurement—Winteria®

The quality of a welded joint has historically been assessed manually using simple mechanical gauges to evaluate the local geometry at discrete points along a weld bead [11]. Stenberg et al. [12] developed a method based on a visual system using the stripe light projection method to measure

the local weld geometry. Further, they developed a numerical evaluation algorithm to allow for stable and objective geometry assessments. This concept is now incorporated in the software Winteria® [13] which carries the practice of weld quality assessment into the digital era giving fast and reliable access to the weld information needed for fatigue life assessment of welded structures [11]. The Winteria® software provides the weld geometric data such as throat thickness, weld toe angle, and weld toe radius. During the HFMI treatment, a highly reflective surface is obtained in the HFMI groove. The HFMI-treated samples were painted with a thin layer of developer spray paint prior to laser scanning. An example of HFMI-treated sample painted with developer paint is shown in Fig. 3. The geometric data of the samples gathered from laser scans was subsequently used to determine the weld quality of the welded samples and produce 3D models for FEM analysis. Digital weld quality measurements, such as laser scanning, is highly accurate and very time-effective in comparison with conventional visual inspection and manual gauges/tools. The laser scanning system Winteria® is able to

**Fig. 2** Potential problem with cracking in weld toe when HFMI treatment on welds with small weld toe angle [1]

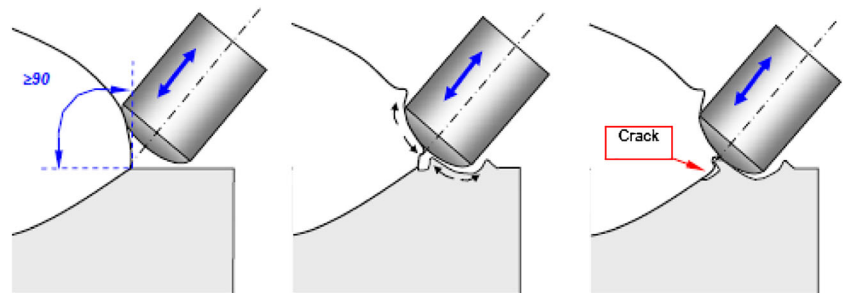

**Table 1** HFMI machines and tools used for PWT

Machine/tool	Pin radius (mm)	Weld quality (prior HFMI treatment)
Machine 1/tool 1	1.5	D-ISO 5817
Machine 1/tool 2	2	D-ISO 5817
Machine 2/tool 3	1.5	D-ISO 5817
Machine 2/tool 4	1.5	D-ISO 5817

measure dimensions down to 6  $\mu\text{m}$ , and the system accuracy is  $> 20$  times the measured dimension. Hammersberg and Olsson [13] conducted a measurement system analysis on conventional gauges for measuring the weld throat thickness. It was concluded that the gauge had a contribution of almost 60% of the total variation, which is too large for Go/No Go decisions ( $> 9\%$ ) and process development ( $> 4\%$ ).

## 2.4 Fatigue testing and angular misalignment

The as-welded samples were tested in an MTS Landmark servohydraulic material testing (10 Hz). The HFMI-treated samples were fatigue-tested in a Rumul Vibroforte 500 resonance test machine (90 Hz). The fatigue testing parameters is summarised in Table 2. One load level was chosen due to the limited number of specimens in each batch. In order to reduce the fatigue testing time, the load level was chosen to be high.

The angular misalignment of the samples was measured prior to fatigue testing. The as-welded samples were measured at multiple points as shown in Fig. 4. The HFMI-treated samples were measured in one position on the flat surface as close to the weld as possible. The range of measured angular misalignment was  $0\text{--}0.2^\circ$  for all samples. The distortion/misalignments measured were insignificant and were considered to have negligible effect on fatigue performance.

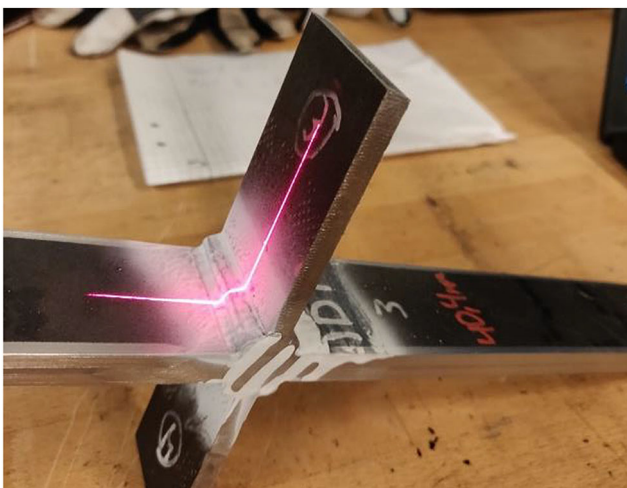
**Fig. 3** Laser scanning of HFMI-treated specimen**Table 2** Fatigue testing parameters

	Number of samples	$\Delta\sigma$ (MPa)	$R$ ratio	Frequency (Hz)
As-welded	12	320	0.1	10
HFMI-treated	24	320	0.1	90

## 3 Finite element analysis

One of the objectives with the finite element analysis (FEA) was to evaluate different software and approaches to incorporate scanned locally weld geometry, point cloud, in the stress analysis, and fatigue life evaluation. However, due large amount of point cloud data from the measurements, it becomes cumbersome to include all the data point, both from pre-processing and CPU point of view. Therefore, different approaches of smoothing by filtering data point were investigated in order to achieve accurate results with considerable smaller amount of data points. The input from laser scan software Wintoria® was of point cloud format that had to be reverse-engineered to obtain a FEM model. A test of how well two different software complete the challenge to replicate a HFMI-treated weld was performed. The software used were NX and ANSYS Workbench. Since the FEA in ANSYS was the step after the modelling, it would be one extra step to import the geometry from NX to ANSYS compared with if ANSYS was used for all steps. In order to reduce the required time, the point cloud was reduced to approximately 15,000 points. An illustration of the geometries from the different software and the corresponding stress analysis is shown in Fig. 5. Number of elements used in each model is approximately  $> 500,000$ , and the element type was an eight-noded 3D solid element (SOLID 185). Figure 6 shows the results from the stress evaluation (von Mises stresses) along at the weld toe along the width of the specimen when ANSYS Workbench and NX is used, respectively. The misalignment,  $0\text{--}0.2^\circ$ , was incorporated in the model for stress analysis. However, negligible stress increase was observed due to the very small misalignment. It can be observed that ANSYS results in higher stress magnitudes locally and larger variation in the stress distribution. NX presents results with smoother stress distribution and lower local stress magnitudes. Hence, NX is more suitable for modelling when stress analysis of welds, 3D-scanned weld geometry, is used.

## 4 Results and discussion

### 4.1 Laser scanning and quality

In Table 3, the geometric data from laser scan measurements is summarised. The result parameters investigated for the

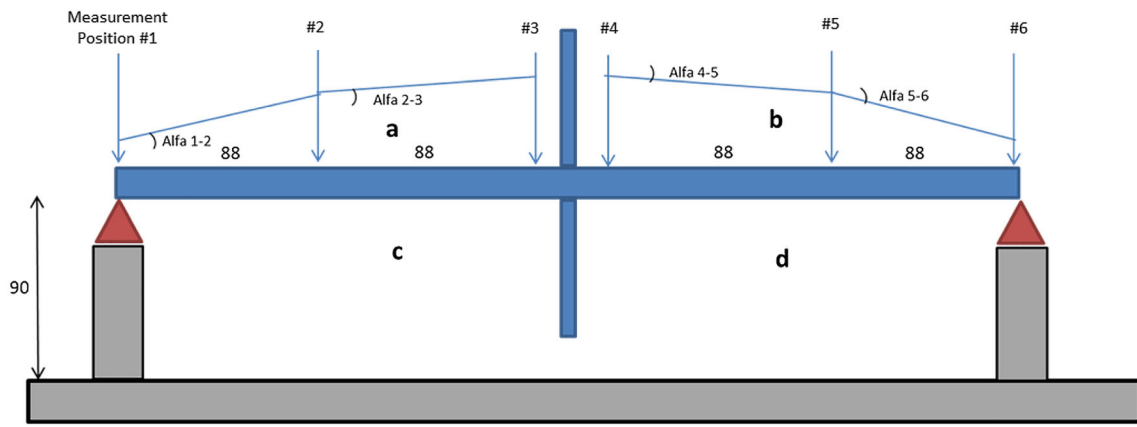
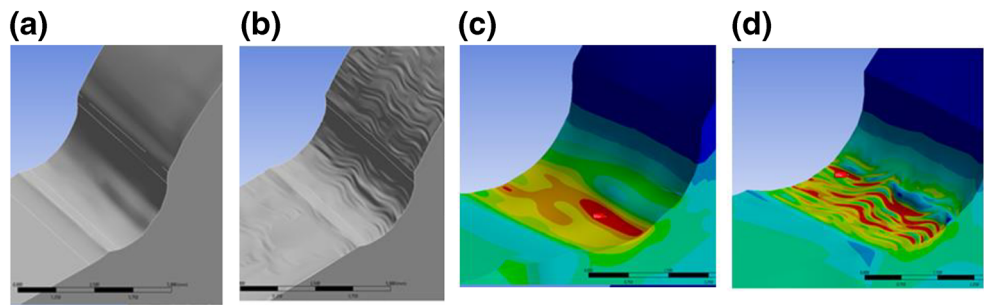

Fig. 4 Schematic view of angular misalignment measurements of as-welded samples

Fig. 5 a NX: geometry. b ANSYS Workbench: geometry. c NX: stress distribution. d ANSYS Workbench: stress distribution



HFMI-treated samples were weld toe radius and undercut; for the as-welded samples, weld toe angle was measured. The weld toe radius gives information about the transition radius in the HFMI groove and the undercut the average HFMI groove depth. These parameters provide reliable and accurate results in the case of 1.5-mm HFMI tool radius in two out of three series. In the case of machine 2/tool 3, the Winteria

software seems to measure the weld toe radius of the small crack shape that is left from the weld toe; this is illustrated in Fig. 7b. The result is useful as the residue crack like weld toe at the bottom of the HFMI groove is considered a defect in [1], and the Winteria software can obviously detect these defects. In the case of machine 1/tool 2, the Winteria software seems to return a smaller than actual value with respect to the weld toe

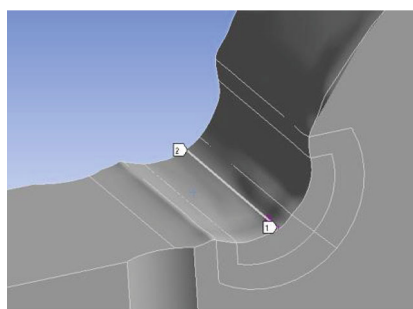

(a)

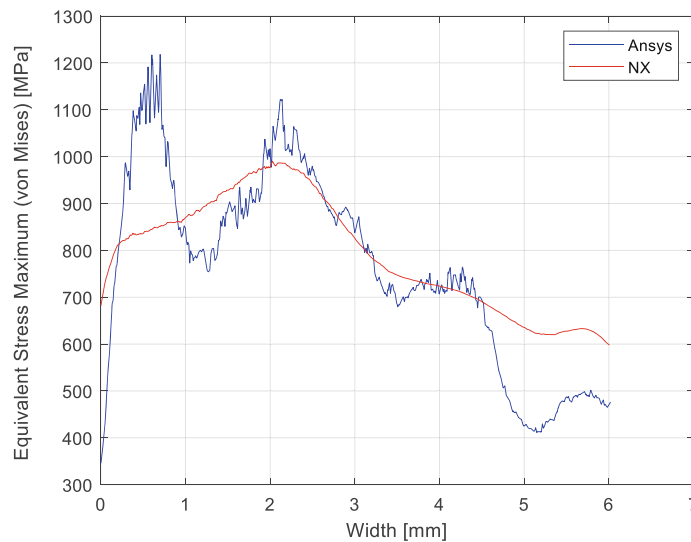

(b)

Fig. 6 a) Path along the weld toe line where the stresses are evaluated. b) von Mises stress distribution along path using ANSYS Workbench and NX

**Table 3** Summary of geometric data from laser scan measurements and analysis. The values are averages and standard deviation of 96 measurements for each HFMI process variants

Machine/tool	Weld toe radius (mm)	Weld toe radius (standard deviation)	HFMI groove depth (mm)	HFMI groove depth (standard deviation)
Machine 2/tool 4	1.33	0.156	0.18	0.09
Machine 2/tool 3	0.50	0.38	0.13	0.06
Machine 1/tool 1	1.30	0.34	0.18	0.08
Machine 1/tool 2	1.37	0.42	0.16	0.09

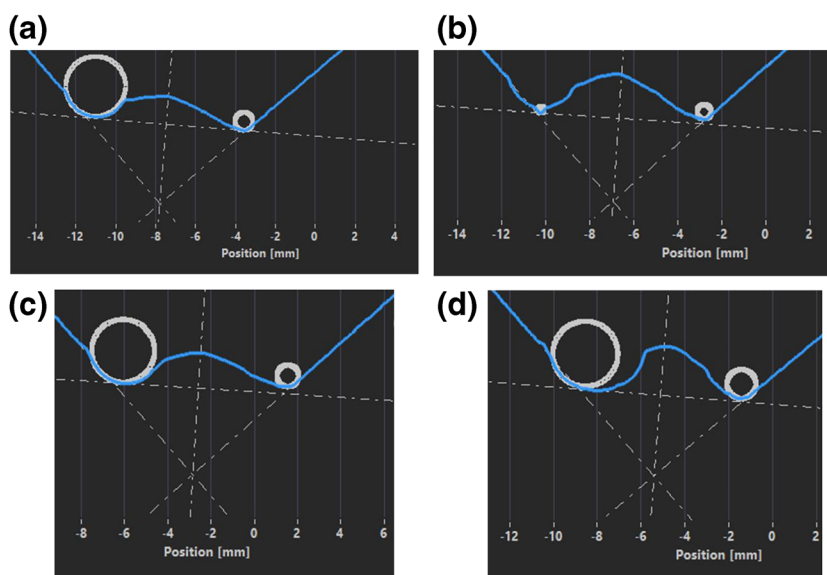
**Fig. 7** Two-dimensional weld profile from laser scanning. **a** Machine 2/tool 4. **b** Machine 2/tool 3. **c** Machine 1/tool 1. **d** Machine 1/tool 2

radius, as illustrated in Fig. 7d. In the case of machine 1/tool 2 and machine 2/tool 4, the Winteria software seems to deliver accurate transition radii; this is illustrated in Fig. 7a and c.

There are multiple geometrical demands the weld must meet according to the IIW recommendations [1]. When welding samples for subsequent HFMI treatment with weld quality level D according to ISO 5817, the weld toe angle was chosen in order to achieve this quality level. The reason is that this factor has the greatest limitation on the accessibility for HFMI treatment of the weld toe. The laser scan data for the as-welded samples are shown in Table 4. It should be noted that the weld toe angle is not directly stated as a demand for weld geometry in [1]; however, extensive convexity is. In this study, it is assumed that extensive convexity and small weld toe angle are analogous. Since it is easier to measure weld toe angle and it is assumed that small weld toe angle is analogous

with extensive convexity, the weld toe angle was chosen as a result parameter when determining weld quality level.

The measurement of weld toe angle is just below the limit for ISO 5817 weld quality level D, which states that weld toe angle for weld quality level D is valid through  $90^\circ < \alpha < 100^\circ$ . However, the welding process is rather unstable at the relatively non-conventional welding parameters used, which leads to quite large deviations in the weld toe angle. The unstable welding process and deviations in the weld toe angle means that locally, the weld intended for weld quality level D will be below the requirements with respect to weld toe angle. However, this study aims to find if HFMI treatment is robust to variations in weld quality, and as shown in Table 4, the weld toe angle is considerably different between the two series. The 2D illustrations of the as-welded samples are shown in Fig. 8.

**Table 4** Laser scanning data for as-welded samples from 48 measurements

	Weld toe angle (average)	Weld toe angle (standard deviation)
As-welded B	129.5	8.3
As-welded D	99.7	8.4

**Fig. 8** The 2D illustrations of the as-welded samples. **a** Weld quality level D. **b** Weld quality level B

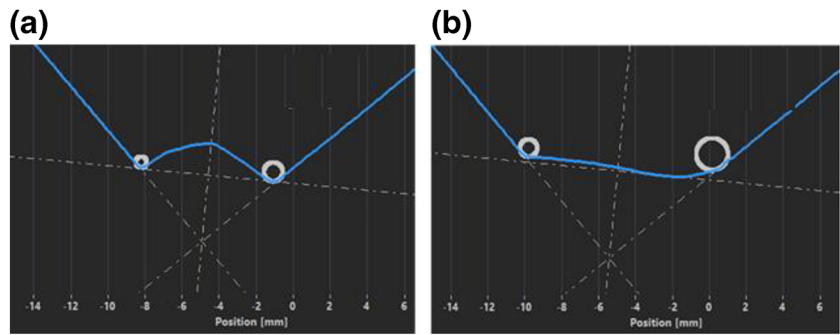

**Fig. 9** Fatigue test results, as-welded, and HFMI-treated compared with guidelines (FAT 80 and FAT 160)

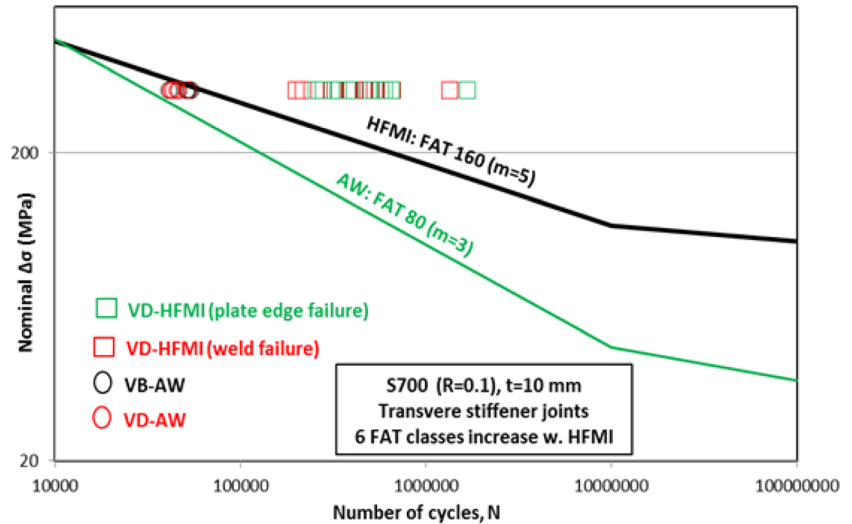

### 4.2 Fatigue test results

In Fig. 9, the fatigue testing results for as-welded and HFMI are presented. The fatigue results are in accordance with the current IIW HFMI recommendations [1] for weld quality level B. The characteristic fatigue strength for transverse stiffener-welded joints is FAT80 ( $m = 3$ ) [12]. According to Marquis

and Barsoum [1], for a structural detail with FAT80 in yield strength of 700 MPa, one can claim 6 FAT class increase for a successful HFMI-treated weld, which will result in a characteristic fatigue strength of FAT160 ( $m = 5$ ). Hence, the HFMI method seems robust to variations in weld quality, and similar fatigue strength improvement can be claimed regardless of weld quality.

**Fig. 10** Box plot of cycles to fracture for each HFMI-treated test series

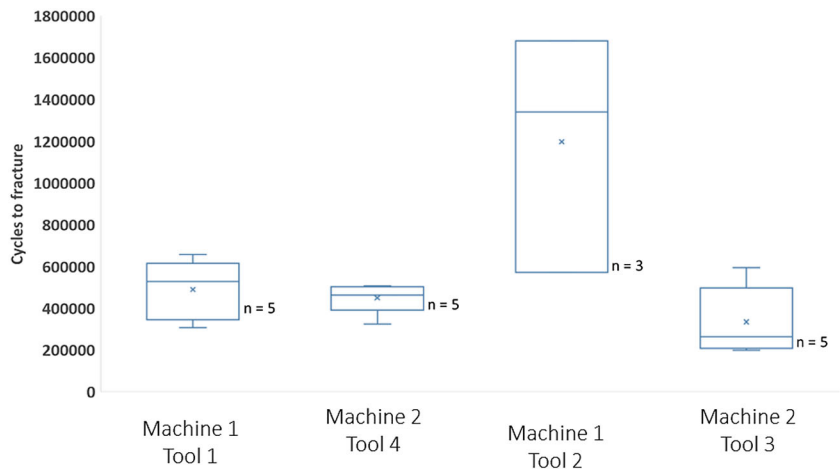



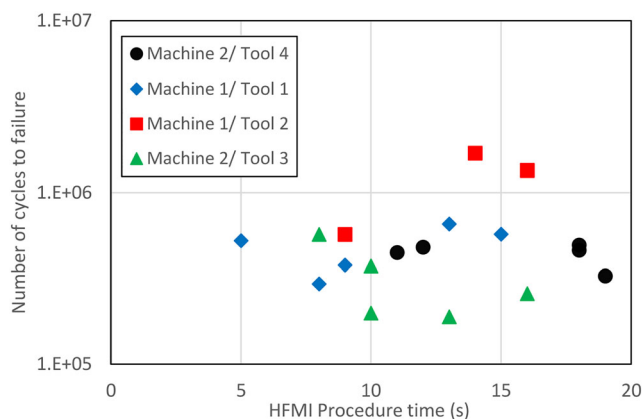

**Fig. 11** Influence from HFMI procedure time on fatigue life

No influence from angular misalignment on fatigue life could be found in either the as-welded or the HFMI-treated samples. The range of measured angular misalignment was 0–0.2° for all samples. Since the angular misalignment was relatively small, the effect from angular misalignment on fatigue life has been neglected in the evaluation.

### 4.3 Effect of post-weld treatment

The robustness of HFMI treatment, the influence of HFMI equipment, HFMI tool, operator as well as procedure time, and number of operations were investigated. A box plot of each HFMI-treated test series is shown in Fig. 10, which shows that no significant difference in fatigue life between the equipment, operator, and tool can be seen when only the tools of 1.5-mm radius are considered. However, the samples treated with the tool of 2-mm radius have a significantly greater fatigue life when compared with samples HFMI-treated with tools of 1.5-mm radius.

The influence of HFMI procedure time on fatigue life is shown in Fig. 11. It can be observed that in the case of HFMI treatment with tool radius of 1.5 mm, the HFMI procedure time seems to have no influence on the fatigue life. However, when considering samples that have been HFMI-

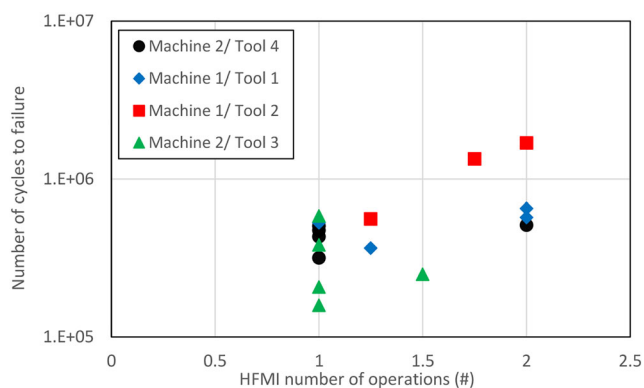

**Fig. 12** Influence of number of HFMI operations on fatigue life

**Table 5** Average maximum stress concentration for all welds in all categories of welds

	Average maximum local stress (MPa)
All HFMI-treated	812
Tool 1	798
Tool 2	749
Tool 3	811
Tool 4	1064
As-welded B quality	822
As-welded D quality	1171

treated with the tool radius of 2 mm, a considerable increase in fatigue life with increased HFMI procedure time is observed, which can have multiple explanations. The larger transition radius created at the weld toe with larger HFMI tool radius contributes to smaller stress concentrations at the weld toe during fatigue testing. With an increased HFMI tool radius, the mass of the tool increases leading to higher impact forces during the HFMI process creating higher indentation depths leading to an increase in compressive residual stresses as indicated by Leitner et al. [7]. The HFMI procedure time dependence observed in the case of HFMI tool radius of 2 mm could be a result of, at lower HFMI procedure times, the procedure cannot achieve proper radius and compressive stresses.

When considering the number of HFMI operations result parameter, a similar correlation is observed to that in HFMI procedure time, see Fig. 12. When considering the samples HFMI-treated with a tool of radius of 1.5 mm, no correlation between number of HFMI operations and fatigue life was observed. However, when considering the samples HFMI-treated with a tool of radius of 2 mm, there seems to be a clear trend between number of HFMI treatment and fatigue life. The assumed cause of this behaviour is analogous to that of

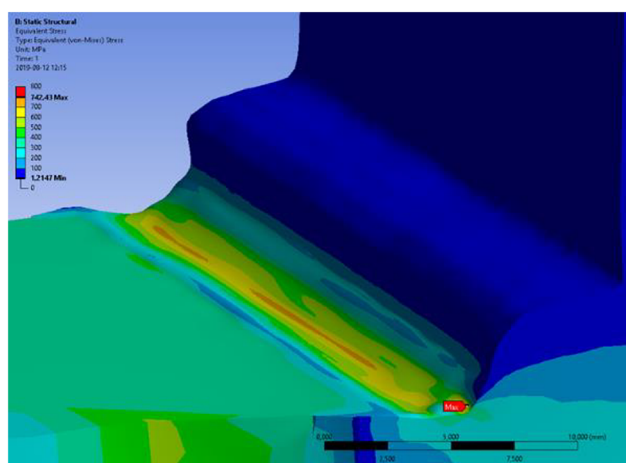

**Fig. 13** Weld 4 FEA where the failure occurred at the right edge of the weld

**Fig. 14** FEA as-welded D quality. **a** Failed, weld 1, FE model gives 1098 MPa as maximum local stress. **b** Predicted failure location according to FEA, weld 4, maximum local stress 1241 MPa

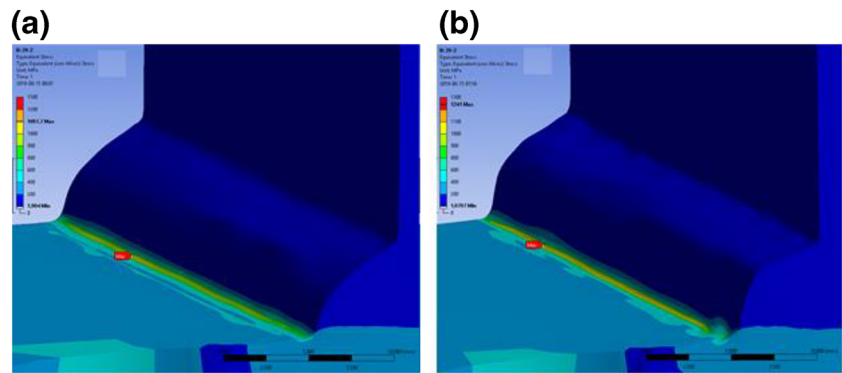

HFMI time, namely that more volume of material is needed to be processed in the case of a greater tool radius and especially when the weld toe angle is as low as it is in this study.

#### 4.4 FEA results

The finite element models show a reduction of stress concentration when the weld is post-processed with HFMI, as shown in Table 5. The stress concentrations are calculated with linear-elastic material behaviour. In general, the stress concentration for HFMI-treated D-quality welds is reduced to a lower value than as-welded B quality. However, it is an exception for tool 4 that has not penetrated as deep as the rest of the tools during the treatment. The smallest maximum local stress of the HFMI-treated welds was a weld treated by tool 2, which is the tool with the largest radius. It is also the tool that gave the lower average maximum local stress.

The welds that are HFMI-treated or as-welded with B quality and have had their failure in the HFMI groove or in the weld toe have the highest local stress in the same weld as the failure occurred in almost all cases. When the failure has occurred at the edge of an HFMI-treated weld, the maximum local stress is not observed in the failed weld, rather in edge where the failure has occurred, see Fig. 13.

The FE models with D-quality welds give no information of which of the welds in the joint will fail first. However, the

welds have their highest local stress in the weld toe. Smoothness of the HFMI treatment is also shown to have a large impact on the local stress. The smoother the HFMI groove is, the lower the maximum stress concentration gets, as shown in Fig. 14.

The results from the FEA give an indication of where the failure might happen. The results also indicate various factors that may influence the distribution of the local stress and thus also the fatigue failure location. Such factors are as follows: groove smoothness, edge sensitiveness, the depth of the groove, and influence of the tool radius. It also showed that the HFMI treatment decreases the local stresses, see Fig. 15.

## 5 Conclusions

In the study, the robustness of HFMI treatment of transverse stiffener fillet-welded joints has been investigated. The robustness was investigated in respect to HFMI operator, equipment, tool, and weld quality level. The main conclusions are the following:

- A significant influence of the HFMI tool on fatigue life was observed; larger HFMI tool radius resulted in greater fatigue life.

**Fig. 15** FEA of HFMI treatment with tool 2. **a** Evenly, HFMI-treated weld with maximum local stress of 700 MPa according to FE model (weld 1). **b** Unevenly, HFMI-treated weld with maximum local stress of 840 MPa according to FE model (weld 2; failed)

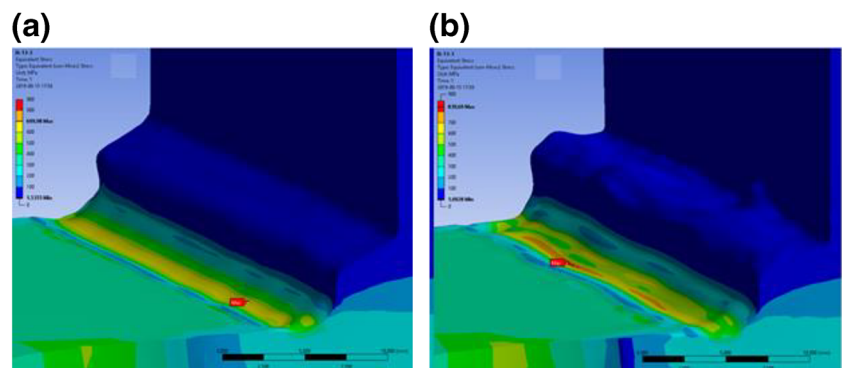

- An increase in fatigue life was observed regardless of the as-welded weld quality level according to ISO 5817. According to IIW [1] for steel grade  $S_Y = 700$  MPa, the fatigue strength recommendation is FAT 160 ( $m = 5$ ) for transverse stiffener-welded joints with as-welded quality B according to ISO 5817 [10], prior to treatment. It can be observed in the current study that fatigue-tested HFMI-treated welded joints, welded with weld quality D, are in good agreement with the IIW recommendations.
- HFMI process time and number of operations influenced fatigue life depending on tool diameter; for 1.5-mm tool radius, no influence on fatigue life from HFMI procedure time or number of operations were observed, whereas for 2-mm tool radius, fatigue life increased with HFMI procedure time and number of operations.
- No significant influence from HFMI operator on fatigue life was observed. However, fatigue life results scatter varied with HFMI operator. No significant influence from HFMI equipment was observed.
- Based on the scanned geometries, the positions of maximum local stress in HFMI-treated welds can be determined using the FEA and the analyses showed to give a good indication of where the failure might occur.

**Acknowledgements** Open access funding provided by Royal Institute of Technology. The authors would also like to thank the other participating companies within this project; SSAB, Volvo CE, Toyota MH, Ecovative Solutions, and WeldHIT.

**Funding information** This study received financial support from the Swedish funding agency VINNOVA under the contract number 2017-05541 within the research project ROMI.

**Open Access** This article is licensed under a Creative Commons Attribution 4.0 International License, which permits use, sharing, adaptation, distribution and reproduction in any medium or format, as long as you give appropriate credit to the original author(s) and the source, provide a link to the Creative Commons licence, and indicate if changes were made. The images or other third party material in this article are included in the article's Creative Commons licence, unless indicated otherwise in a credit line to the material. If material is not included in the article's Creative Commons licence and your intended use is not permitted by statutory regulation or exceeds the permitted use, you will need to obtain permission directly from the copyright holder. To view a copy of this licence, visit <http://creativecommons.org/licenses/by/4.0/>.

## References

1. Marquis GB, Barsoum Z (2016) IIW Recommendations for the HFMI Treatment - For Improving the Fatigue Strength of Welded Joints, Springer
2. Haagensen PJ, Maddox SJ (2013) IIW recommendations on methods for improving the fatigue strength of welded joints: IIW-2142-110. Woodhead publishing
3. Marquis G, Mikkola E, Yildirim H, Barsoum Z (2013) Fatigue strength improvement of steel structures by HFMI: proposed fatigue assessment guidelines. *Weld World* 57:803–822
4. Marquis G, Barsoum Z (2014) Fatigue strength improvement of steel structures by HFMI: proposed procedures and quality assurance guidelines. *Weld World* 58:19–28
5. Yildirim HC (2015) Review of fatigue data for welds improved by tungsten inert gas dressing. *Int J Fatigue* 79:36–45
6. Khurshid M, Barsoum Z, Marquis G (2014) Behavior of compressive residual stresses in high strength steel welds induced by high frequency mechanical impact treatment. *J Pressure Vessel Technol* 136(4):041404
7. Leitner M, Khurshid M, Barsoum Z (2017) Stability of high frequency mechanical impact (HFMI) post-treatment induced residual stress states under cyclic loading of welded steel joints. *Eng Struct* 143:589–602
8. Leitner M, Barsoum Z, Schäfers F (2016) Crack propagation analysis and rehabilitation by HFMI of pre-fatigued welded structures. *Weld World* 60(3):581–592
9. Tehrani Yekta R, Ghahremani K, Walbridge S (2013) Effect of quality control parameter variations on the fatigue performance of ultrasonic impact treated welds. *Int J Fatigue* 55:245–256
10. ISO/TC 44/SC 10 (2011) ISO 5817:2007, welding-fusion-welded joints in steel, nickel, titanium and their alloys-quality levels for imperfections, SIS
11. Stenberg T, Barsoum Z, Åstrand E, Ericson Öberg A, Schneider C, Hedegård J (2017) Quality control and assurance in fabrication of welded structures subjected to fatigue loading. *Weld World* 61(5): 1–13
12. Hobbacher A (2009) IIW recommendations for fatigue design of welded joints and components, vol 520. WRC, Welding Research Council Bulletin, New York
13. Hammersberg P, Olsson H (2010) Statistical evaluation of welding quality in production. In: Barsoum Z (ed) Proceedings of Swedish conference on lightweight optimised welded structures. Borlänge, Sweden, pp 48–162

**Publisher's note** Springer Nature remains neutral with regard to jurisdictional claims in published maps and institutional affiliations.