

# Word Hardware-oriented algorithm for extracting periodic sequence of digital signals

V.S. Panishchev<sup>1</sup>, S.N. Poltoratskiy<sup>1</sup>

<sup>1</sup>Southwest State University, 50 let Oktyabrya 94, Kursk, Russia, 305040

**Abstract.** The problems of applying pulse sequence processing algorithms at the hardware level to specialized hardware for image processing and recognition systems, monitoring, analysis, control and diagnostics of complex technical objects and man-machine systems are considered. A hardware-oriented algorithm for extracting periodic sequences in control and digital signal processing devices is described. To improve the detection of deterministic sequences the algorithm analyzes multiple values of the period of pulses arrival by weighted processing. A structural-functional organization of a specialized device is developed that implements a hardware-oriented algorithm for extracting periodic sequences of digital signals. The operation of a specialized device is briefly presented. A comparative analysis of the algorithms based on test samples is performed. The simulation was carried out in 30 samples, including from 2 to 10 mixed periodic sequences in each of them. As a result, the developed algorithm isolated periodic sequences with a reliability of at least 0.8, which is 1.3-1.4 times better than the reliability achieved by analogues with the same number of sequences in the sample.

## 1. Introduction

Currently, there is a tendency to increase the number of simultaneously functioning signal sources, in the presence of dynamically changing impulse parameters and widespread use of signals with a complex structure, which leads to an increase in the requirements for the reliability of identifying sequences of such signals and for the speed of input stream processing algorithms.

For a qualitative and quantitative description of the received deterministic signals, a special device is needed that allows to select periodic sequences based on the estimation of the amplitude-time and frequency parameters of digital signals for further processing in a device or computer.

Such devices are used in specialized hardware for image processing and recognition systems, monitoring, analysis, control and diagnostics of complex technical objects and human-machine systems, such as medical diagnostics, remote monitoring systems, intelligent video surveillance systems and robotics, to expand the functionality regarding detection, estimation of amplitude-time and frequency parameters, extraction of periodic sequences of digital signals for subsequent selection and classification of pulse signals from the flow parameters.

Known devices have several disadvantages [1]:

- lack of algorithms for extracting a priori unknown sequences of digital signals;
- use of outdated element base;
- determination of only part of the pulse parameters (duration and time of arrival of pulses);
- lack of modern interfaces for transmitting calculated data to computers.

## 2. Method description

The aim of the research is a hardware-oriented implementation of the algorithm for extracting periodic sequences of digital signals [2], using a qualitatively expanded list of calculated pulse parameters [3], as well as a modern element base.

It was shown in [4] that to increase the detection efficiency of deterministic sequences, one should use the analysis of multiple values of the pulse arrival period with weighted processing. This approach uses the sorting of the digits of the histogram of the difference taking into account multiple values of the pulse arrival period and the weight function when detecting the periodicity of a digital signal for calculating test statistic:

$$Kr = \sum_{i=1}^h yh(i \cdot T_o) * vk_i > hold, \quad (1)$$

where  $h$  is a positive integer, a coefficient that determines the level of control of multiple periods,  $yh$  is a histogram of the periods of pulse arrival,  $T_o$  is the desired period of the sequence,  $vk_i = \frac{1}{i+1}$  are weight coefficients,  $hold$  is an adjustable detection threshold.

The analysis of multiple values of the pulse arrival period is based on adding to the calculated number of matches (actual pulse of the sequence) a predetermined number of matches corresponding to the forecast  $h$ -intervals. The value of  $h$  is essentially a threshold at which a final decision is made about the correct detection of a sequence. In this case, the analysis of the multiplicity is applicable both for constructing a histogram of the difference, and for making a balanced decision on the presence of periodicity based on an estimate of its digits (the used value is  $l$ ).

The developed hardware-oriented algorithm for extracting periodic sequences of digital signals (Fig. 1) provides hardware implementation of a histogram analysis of the input sample with a balanced decision on the availability of frequency and search by time of arrival (using retrospective elements of the signal over time) and has high reliability and speed of selection compared to known algorithms.

The developed structural and functional organization of a specialized device (Fig. 2) implements a hardware-oriented algorithm for extracting periodic sequences of digital signals using a weight function.

A specialized device operates as follows.

Before the signals arrive at the input, the device is calibrated by the intrinsic noise of the input paths, which mainly determine the noise level. Based on the calibration results, thresholds for detecting pulses against noise are calculated and stored. At the input of the device, a signal  $s(t)$  is supplied at intermediate frequency, consistent with the clock frequency of the clock  $F_T$ .

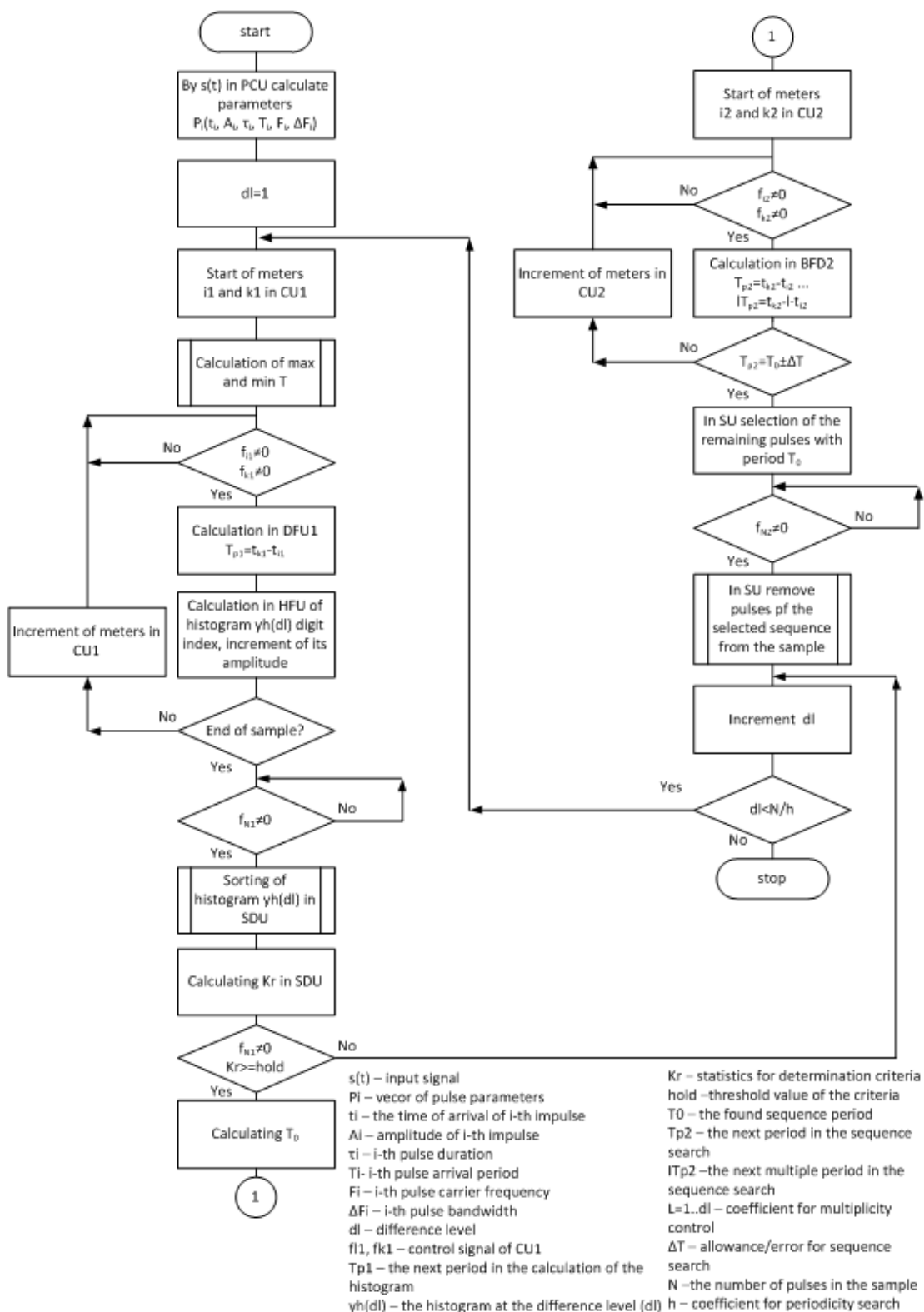
As a result of the ADC operation, the analog signal is converted into a set of amplitude-time samples  $s_\delta(t) = \{Ap_j, tp_j\}$ . Further, in the PCU, the calculation of the pulse parameters of digital signals  $P_i$  with the recording of the results in the memory is implemented.

The blocks following PCU implement a hardware-oriented algorithm for extracting periodic sequences of digital signals using the weight function presented above.

The parameters of the selected sequences are recorded in the memory, and by a special command are copied to the computer for further processing of the sequence. As a result of the device operation, an array of descriptions of impulse sequences  $\{D\}$  is formed. Each sequence corresponds to a selected set of impulse descriptions in the memory.

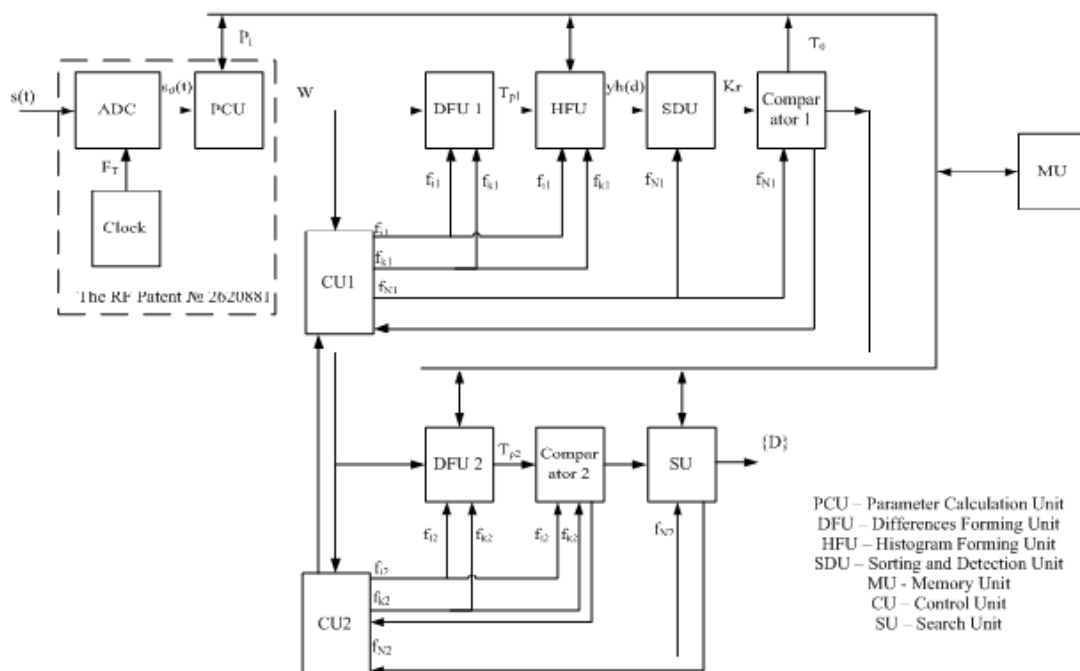
In course of modeling the work of the developed algorithm and device, a comparative analysis was performed with analogues [5, 6]. The simulation was carried out in 30 samples, including from 2 to 10 mixed periodic sequences ( $x=2 \div 10$ ) in each of them. Fig. 3 shows the obtained reliability with respect to the processing time. Asymptotes (dashed lines) combine the results obtained by analogues and the developed algorithm during the experiment on samples with the same number of sequences  $x$ .

As a result, the developed algorithm extracted periodic sequences with a reliability ( $H$ ) of at least 0.8, which is 1.3-1.4 times better than the reliability achieved by analogues with the same number of sequences ( $x$ ) in the sample. The algorithm allows to increase the reliability of the selection of sequences in those cases where traditional approaches give solutions, in particular, for noisy and mixed samples.

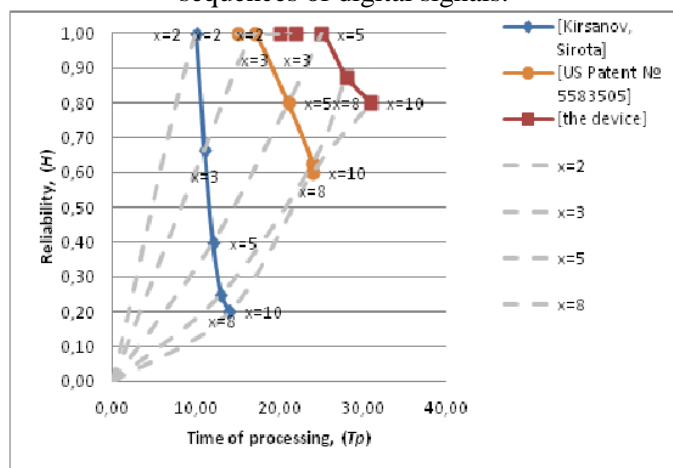


**Figure 1.** Hardware-oriented algorithm for allocating periodic sequences of digital signals.

In image analysis tools, the device is applicable as a means of preliminary processing of both TV signals and digital bitmap images in order to extract images, texture segmentation, etc. In this case, the processing of the image frame is realizable “in the pass” (in real time), which is impossible with known means.



**Figure 2.** Structural and functional organization of a specialized device for extracting periodic sequences of digital signals.



**Figure 3.** The graph of the reliability ( $H$ ) of the extracting of sequences from the processing time ( $T_p$ ) of a digital signal obtained during an experimental study ( $x$  is the number of sequences).

In systems for monitoring and processing data from air traffic control devices, the device is applicable at the preliminary stage of processing object signals to reliably extract standardized digital signals. This area is characterized by a high-intensity signal flow per unit time, as well as a mixture of signals that are uniform in their temporal structure at the receiving point, as a result of which the processing of the signal stream from many objects should be performed using a modern efficient algorithm.

Thus, a specialized device for extracting periodic sequences of digital signals in comparison with analogs provides the calculation of a larger number of pulse parameters, and also increases the reliability of the extracting of periodic sequences.

### 3. Findings

- The reliability of extracting sequences of events in mixed samples is enhanced by using the weight function in the analysis of multiple periods.

- It is advisable to use the developed algorithm in control devices in the subsystem for analysis and processing of noisy or mixed sequences of digital signals.

In general, the considered algorithm is based on the operation of addition and subtraction of integers and therefore is effectively implemented on high-speed FPGAs of the Xilinx family.

#### 4. References

- [1] Poltoratskiy, S.N. Application of means of digital sequences deduction in preliminary signal processing devices / S.N. Poltoratskiy, V.S. Panishchev, V.S. Titov, A.P. Loktionov // Proceedings of the Southwest State University. Series: Control, Computer Engineering, Information Science. Medical Instruments Engineering. – 2018. – Vol. 8(3). – P. 16-24.
- [2] Poltoratskiy, S.N. Algorithm of weighted search of pulse sequences in devices for event stream processing / S.N. Poltoratskiy, V.S. Panishchev, V.S. Titov / Telecommunications. – 2018. – Vol. 11. – P. 2-7.
- [3] Durne, S.L. Odnokanal'noye ustroystvo izmereniya amplitudno-vremennykh i chastotnykh parametrov signalov s tsifrovym detektirovaniyem / S.L. Durnev, S.N. Poltoratskiy // Patent 2620881 Rossiyskaya Federatsiya, MPK G01R29/02, zayavl. 11.04.2016g, opubl. 30.05.2017, byul. # 16.
- [4] Poltoratskiy, S.N. Method of temporary selection of pulse sequences in devices for pulse signals processing / S.N. Poltoratskiy, V.S. Panishchev // Proceedings of the Southwest State University. Series: Control, Computer engineering, Information Science. Medical instruments engineering. – 2017. – Vol. 7(4(25)). – P. 41-48.
- [5] Andersen, D.P. Radar pulse detection and classification system / D.P. Andersen, S.A. Murphy // United States Patent № 5583505 МПК G01S 7/40 1996.
- [6] Kirsanov, E.A. Obrabotka informatsii v prostranstvenno-raspredelennykh sistemakh radiomonitoringa: statisticheskiye i neyrosetevyye podkhody / E.A. Kirsanov, A.A. Sirota – M: Fizmatlit, 2012 – 344 p.