

Old Dominion University

## ODU Digital Commons

---

Educational Foundations & Leadership Theses  
& Dissertations

Educational Foundations & Leadership

---

Summer 8-2020

### Possible Self Dynamics of Community College Students Engaged in 3D Printing in Informal Environments

Lawrence Ralph Nightingale Jr.

*Old Dominion University*, [lawrence.r.nightingale@gmail.com](mailto:lawrence.r.nightingale@gmail.com)

Follow this and additional works at: [https://digitalcommons.odu.edu/efl\\_etds](https://digitalcommons.odu.edu/efl_etds)



Part of the [Engineering Education Commons](#), [Feminist, Gender, and Sexuality Studies Commons](#), and the [Secondary Education Commons](#)

---

#### Recommended Citation

Nightingale, Lawrence R.. "Possible Self Dynamics of Community College Students Engaged in 3D Printing in Informal Environments" (2020). Doctor of Philosophy (PhD), Dissertation, Educational Foundations & Leadership, Old Dominion University, DOI: 10.25777/epb5-k171  
[https://digitalcommons.odu.edu/efl\\_etds/241](https://digitalcommons.odu.edu/efl_etds/241)

This Dissertation is brought to you for free and open access by the Educational Foundations & Leadership at ODU Digital Commons. It has been accepted for inclusion in Educational Foundations & Leadership Theses & Dissertations by an authorized administrator of ODU Digital Commons. For more information, please contact [digitalcommons@odu.edu](mailto:digitalcommons@odu.edu).

**POSSIBLE SELF DYNAMICS OF COMMUNITY COLLEGE STUDENTS ENGAGED  
IN 3D PRINTING IN INFORMAL ENVIRONMENTS**

by

Lawrence Ralph Nightingale Jr.  
B.A. May 1995, University of Richmond  
M. Ed. 1997, University of Virginia

A Dissertation Submitted to the Faculty of  
Old Dominion University in Partial Fulfillment of the  
Requirements for the Degree of

DOCTOR OF PHILOSOPHY

COMMUNITY COLLEGE LEADERSHIP

OLD DOMINION UNIVERSITY

August 2020

Approved by:

Christopher Glass (Director)

Felicia Commodore (Member)

Karina Arcaute (Member)

## **ABSTRACT**

### **POSSIBLE SELF DYNAMICS OF COMMUNITY COLLEGE STUDENTS ENGAGED IN 3D PRINTING IN INFORMAL ENVIRONMENTS**

Lawrence R. Nightingale Jr.  
Old Dominion University, 2020  
Director: Dr. Christopher Glass

The overall number of students from diverse backgrounds and women that graduate from community college with degrees in high paying Science Technology Engineering and Mathematics (STEM) disciplines is unacceptably low. The number of opportunities to gain exposure to STEM-based expressions of technology to overcome the dearth of exposure in high school is limited in community college. 3D Printing uses computer-controlled machines to build physical objects one layer at a time starting from the bottom up. The computer-controlled nature of 3D Printing provides a low risk, low cost platform to exercise elements of computer programming and engineering.

This study was a phenomenological, qualitative study that was designed to fully describe the process of community college student engagement with 3D Printing. There were three data collection components in the study; first was an initial interview combined with naturalistic observation. Second was recorded documentation in the form of 3D printed objects that students produced. Third was a culminating interview of the participants after they had engaged in a critical number of 3D Printing activities.

The results of the study were overwhelming. Students who aspired to be engineers used the lab to sharpen their skills in a low-stakes, high reward setting. Students who worked in the lab expressed greater confidence in their STEM skills. Students considered changing their majors to STEM academic courses of study from social science. Female students overcame a lifetime of

counter-messages about women in STEM. Finally, a mountain biking component was designed, manufactured, and field tested by an aspiring engineer who had yet to take a single course in the college engineering curriculum.

Based on the findings, it is recommended that 3D Printing be applied more broadly in student supported, peer educated lab settings. STEM majors, in particular engineering and computer science students see a great value in using the machines. Long term study of the retention and graduation rates of students who engage in 3D Printing will be useful for colleges and universities who seek to increase the number of graduating STEM majors at their institutions.

Copyright, 2020, by Lawrence Ralph Nightingale Jr., All Rights Reserved.

This dissertation is dedicated to my family. My Mother and Father who encouraged me to try my best. My Grandmother who always told me I was smart, no matter the timing or volume of evidence to the contrary. My Wife who tolerates more than any human should in their lifetime, and my daughter for whom I must carve a path.

This dissertation is also dedicated to the high paying STEM jobs and the stubbornly static diversity profile therein. Community college graduates of all stripes will soon join your ranks, not because of what they learn in the classroom, but because of the innovations and discoveries that they engage in outside of it. The 21<sup>st</sup> century will be the century of the independent thinker, the outside innovator and the disruptive designer. For pennies on the dollar, each of these 21<sup>st</sup> century professionals will contribute greatly with a modicum of formal knowledge and a plethora of resources at their fingertips.

## ACKNOWLEDGMENTS

I would like to acknowledge The Old Dominion University Community College Leadership program and the residential and academic experience that it delivers. The residency of the program allowed me to feel like an eager learner all over again. With special appreciation for Dr. Mitchell Williams' discipline and dedication at long distance. Dr. Karina Arcaute whose expertise, wisdom and skill are literally "longer than train smoke." Dr. Dana Burnett who encouraged me to pursue a subject that I was passionate about.

It is a pleasure to acknowledge Dr. Felicia Commodore. Dr. Commodore reveals insight through her masterful methods of inquiry, her questions motivate me to be optimally reflective about the data. Her thoughtful questions and probing methods inspired me to make the deep connections necessary for the data collection and analysis of this dissertation to be Critical with a capital "C".

I must acknowledge Dr. Christopher Glass whose ability to frame a major occurrence as a non-event is legendary. I appreciate his stoic persistence. His legendary experience. His genius suggestions. His ability to multitask. His leadership. With Dr. Christopher Glass I would not have the occasion to dream that I could make a difference in education.

I would like to acknowledge Dr. Adrian Bowyer who played the 3D Printed cello that my students fabricated with great delight. Without his contribution, none of this work, the reported revolutions of thought, the skills gained, or the enormous volumes of plastic objects fabricated would be possible.

I would like to acknowledge the NOVA Foundation for funding the programming of the NOVA Woodbridge Innovation lab. Never before in history could a sum of less than \$10,000 provide learning aids to the blind, raise the study of Women's literature an unprecedented level,

launch a robotics team, train a new kind of educator, and highlight the extraordinary contributions of women in STEM.

I would like to acknowledge Professor Indigo Eriksen. For agreeing to bring a new technology into the study of Women's literature. The day that I taught her students how to design 3D Printable objects was literally the busiest day of my professional life. Her willingness to collaborate and make connections with her established network of professionals made the Glenny Penny, and many other delightful innovations possible.

I would like to acknowledge Dr. Evette Hyder-Davis for establishing the Technology Innovation lab, without Dr. Davis there would be no location, no hardware, no resources for students from diverse background to discover what they are capable of when they control technology. Finally, I would like to acknowledge the students and professionals at NOVA Woodbridge, without whom the exercise of writing this work would be devoid of character.



## TABLE OF CONTENTS

<b>LIST OF TABLES .....</b>	<b>x</b>
<b>LIST OF FIGURES .....</b>	<b>xi</b>
<b>CHAPTER 1 .....</b>	<b>1</b>
<b>INTRODUCTION.....</b>	<b>1</b>
Women in STEM Careers .....	4
The Maker Movement.....	4
3D Printing and the Maker Movement .....	5
3D Printing and STEM Education .....	5
3D Printing in Higher Education .....	7
Conceptual Framework .....	9
<b>Research Questions.....</b>	<b>10</b>
Significance of the Study .....	11
Overview of Methodology .....	12
Delimitations.....	12
<b>Definition of Key Terms .....</b>	<b>12</b>
<b>Chapter Summary .....</b>	<b>14</b>
<b>CHAPTER 2 .....</b>	<b>15</b>
<b>LITERATURE REVIEW .....</b>	<b>15</b>
Graduation Rates of Community College STEM Programs.....	15
3D Printing at Community Colleges.....	17
STEM Degrees at Community Colleges by Field.....	17
Barriers in STEM Education.....	18
Relatability of the STEM Curriculum.....	19
Intelligence Paradigm Barriers .....	19
Social and Global Aspects of STEM Participation.....	21
Informal Education .....	24
<b>Framing STEM in Community colleges .....</b>	<b>25</b>
Problem and Project Based Learning.....	25
Postphenomenology .....	26
Possible Selves.....	28
<b>Chapter Summary .....</b>	<b>30</b>
<b>Chapter 3 .....</b>	<b>31</b>
<b>METHODOLOGY .....</b>	<b>31</b>
Research Methods.....	31
Research Questions.....	32
Critical Constructivism .....	33
Participants.....	34
Site Description.....	35
<b>Data Collection .....</b>	<b>37</b>
Study Procedures .....	40
Data Analysis .....	41
Credibility .....	42
Limitations .....	43

Role of the Researcher .....	44
Conclusion .....	45
<b>Chapter Summary .....</b>	<b>45</b>
<b>CHAPTER 4 .....</b>	<b>46</b>
<b>DATA ANALYSIS .....</b>	<b>46</b>
<b>Trends in Collected Data .....</b>	<b>49</b>
Student Identity .....	49
Past Self Knowledge Construction Process .....	51
Misshapen Self to Future STEM practitioner .....	54
Technological Exploration Shaping Student Identity .....	54
Expected Self Resolution Increased through 3D Printing .....	60
Factor: Outside Actors .....	65
Influential Teachers .....	66
Factor: Environment .....	70
Lab Setting Stimulates Knowledge Construction .....	77
3D Printing and Gender Norm Amendments.....	84
Gender Norms Shaping Possible Self Dynamics.....	85
3D Lab and Gender Nexus.....	91
<b>Chapter Summary .....</b>	<b>100</b>
<b>CHAPTER 5 .....</b>	<b>105</b>
<b>DISCUSSION .....</b>	<b>105</b>
Summary of Findings.....	105
Findings Across the Body of Research.....	108
Facilitating Gender Diversity.....	111
Future Steps .....	113
Concluding Remarks.....	115
<b>References .....</b>	<b>117</b>
<b>Appendix A .....</b>	<b>129</b>
3D Printing Interview Questions .....	129
<b>Research Participant Information and Consent Form.....</b>	<b>131</b>
<b>Appendix C .....</b>	<b>135</b>
3D Printing Infinity Gauntlet .....	135
<b>Appendix D .....</b>	<b>137</b>
Outreach materials for 3D Printing and Robotics Club (3D PARC).....	137

**LIST OF TABLES**

Table

1. Participant Descriptions.....137

2. Participant Objects Printed and Events Attended.....138

3. Participant Snapshots and Overarching Quotes.....139

## LIST OF FIGURES

Figure

1. Possible Self Progression with 3D Printing.....	141
2. .stl files of 3D Printed Objects.....	142

**CHAPTER 1**  
**POSSIBLE SELF DYNAMICS OF COMMUNITY COLLEGE STUDENTS ENGAGED**  
**IN INFORMAL LEARNING CONTEXTS USING 3D PRINTING**

**INTRODUCTION**

Computerization and automation drove a wellspring of new business and wealth in the technology sector during the late 20th century that continues to this day (Bureau of Labor Statistics, 2014). Although the percentage of females in the United States (US) workplace is 48 percent, only 26 percent of workers in Science Technology Engineering and Mathematics (STEM) fields are women (Landivar, 2013). High paying jobs in the STEM fields have had a reasonably static diversity profile since the advent of computerization and automation (Landivar, 2013). Careers in the STEM fields are significantly higher paying than careers in education and social science (Melguizo & Wolniak, 2011). The growth of STEM-related and computer science jobs was the highest in the US for the ten years between 2004 to 2014. In that time, initiatives were instituted to encourage women and students from diverse backgrounds to pursue STEM education. Efforts to shift the diversity profile in STEM careers have not significantly changed the ethnic and gender makeup of the field. (Jen-Mei, Chuhee, Stevens, & Buonora, 2016)

The stubbornly disproportionate diversity profile of the STEM industry implies that previous approaches to increasing diversity and inclusion have fallen short in critical but unexamined dimensions. It is possible that previous approaches did not provide learners from diverse backgrounds with a way to see themselves applying STEM concepts plausibly. The way in which humans come to see their options for future successful endeavors is fluid (Markus & Nurius, 1986). Our current, immediate “human experience” is related to our viewing of future options, but it can also be restricted by it (Oyserman & Markus, 1990). The mind vividly

constructs images of freedom from inside a prison, although a long enough tenure until that freedom is granted can dull the sharpness of this imagined future. A person working a fast food drive-through window can daydream a version of herself as a small business owner, a teacher, or a computer programmer. Repeated daydreams of a particular theme can develop into a representation of a future self (Markus & Nurius, 1986). Particularly strong instances of daydream imagery that turn into a representation of fears, hopes, or a specific future is known as a *possible self* (Markus & Nurius, 1986). The body of research on STEM enrichment and instruction does not yield any significant instances of considering the possible self in the delivery and plausibility of STEM instruction.

The process of developing an academically oriented possible self for students in higher education is poorly understood (Lee, Husman, Scott, & Eggum-Wilkens, 2015). The possible self can change dynamically according to the experience of the individual (Creech et al., 2014; Ozaki, 2016). As it applies to higher education, the possible self factors into the goals that students avoid or gravitate towards pursuing (Stevenson & Clegg, 2011). Competing possible selves such as parent, student, wage earner, and spouse can become influential as factors in community college student stop out or continuation decision making (Ozaki, 2016). Enrichment opportunities such as internships and student-initiated research are effective tools for encouraging and supporting retention in STEM majors outside of credit coursework. (Amelink, Artis, & King Liu, 2015; Finkel, 2017). The period in time in which community college students engage in coursework presents an opportunity to insert, change, amend, or re-animate a possible self that is aligned with a successful STEM student ideation. The aim of the following study was to gather data about the reported influence of STEM activities on the possible self for students enrolled in community college.

The US community college system is the most widely used entry point into the Science and Engineering fields for women and students from diverse backgrounds. Almost half of the STEM jobs in the US require a two-year degree (Rothwell, 2013). The body of research that informs this study was intended to develop new, multifaceted ways to improve the success rate of community college students in STEM programs of study. Research studies that focus on increasing STEM academic success rates include data that suggest that community college students benefit from interventions that inspire greater self-efficacy and achievement in Mathematics (Wang, 2013). Other studies emphasize the importance of outreach and recruiting with significant levels of faculty/student interaction and undergraduate research within a welcoming atmosphere (Doerschuk, 2016; Smith & Wingate, 2016). Comprehensive approaches that include extensive service-learning and time investment from students and STEM mentors are proven to have the greatest effect on student success and retention (Daniel, 2017).

Throughout higher education, the process of gaining access to the STEM fields is fraught with biases and traditionalism. The biases are rooted in established patterns of empirical reliance on specific quantitative measures such as IQ and academic GPA. The traditionalism centers around the concept that innate ability, talent, and unteachable aptitude are necessary to succeed in STEM (Leslie, Cimpian, Meyer, & Freeland, 2015). The traditional route of access to STEM must be augmented in real time in order to make substantial change in the gender and ethnic makeup of professionals in the science and technology industries. New unorthodox approaches that are outside of traditional STEM higher education practices should seek to contribute meaning and connection for community college students, highly effective, new approaches would likely bolster the ranks of existing STEM majors and potentially divert students from

social science, business and trade curriculums into higher paying and diversity emaciated STEM fields.

### **Women in STEM Careers**

There is a lack of representation of women in the Science and Engineering fields (NSF, 2017). The body of work in STEM that presents information to suggest that women are actively and passively dissuaded from STEM pursuits in higher education is a substantial component of this study (Flanigan, Peteranetz, Shell, & Soh, 2017; Leslie, Cimpian, Meyer, & Freeland, 2015; Rattan, Good, & Dweck, 2012). The evidence of cultural and institutional mores and actions that contribute to gender pay inequity informs the urgency of this study (McGivney-Burelle & Xue, 2013).

### **The Maker Movement**

The *maker movement* had a television show in the early 2000s called *Mythbusters*. *Mythbusters* embraced the exploration of STEM and the scientific method in fun and engaging ways. The show took audience questions about the world and tested those questions under semi-scientific conditions. The show was an adequate source of energetic scientific activity for primary and secondary school STEM instruction (Wood-Black & Pasquarelli, 2005). The show also created opportunities for the application of STEM as a student-centered active learning experience (K. Smith & Hughes, 2013). Although *Mythbusters* was canceled in 2018, the spirit of STEM-based exploration is still supported by a substantial cache of fun and engaging opportunities. Video databases such as YouTube and Vimeo are a source of instruction and knowledge for students to institute their own academic and entertainment-based STEM exploration.



### **3D Printing and the Maker Movement**

Prominent support of 3D Printing is apparent in a variety of educational settings, elementary schools, high schools, and four-year institutions use 3D Printing in concerted efforts with non-profits, government agencies, and business everywhere in the education industry. (H. Kwon, 2017; Maloy, Trust, Kommers, Malinowski, & LaRoche, 2017; Newman, Dantzler, & Coleman, 2015). 3D printers are capable of producing any number of objects using low cost, open source instructions, hardware, and firmware files (Jones et al., 2011). The first open source 3D printer was manufactured in 2006, since then, there has been a wellspring of excitement and economic activity around the technology (Jones et al., 2011). Until this study, there has been little research that explores the use of 3D Printing as a tool for developing an identity that is parallel with STEM coursework in community college students.

### **3D Printing and STEM Education**

3D Printing is an existing technology that has become significantly accessible to hobbyists and professionals. Community college students can benefit from learning how to 3D print via workforce education or coursework in transferable engineering degrees (Simpson, Williams, & Hripko, 2017). 3D Printing is a fun, STEM-based activity that stimulates entrepreneurial thinking and promotes problem solving skills (Simpson et al., 2017). Furthermore, 3D Printing is a skills set that employers are interested in exploring for use in small scale manufacturing and highly customizable applications (Go & Hart, 2016).

3D Printing is an activity that has a foundation in STEM, it is accessible and has broad appeal. These factors formulate the reasons why this research is unique and necessary. First, it is possible that exposure to 3D Printing technology could influence more students in community college to see themselves as STEM practitioners and STEM majors. Second, it is possible that

exposure to 3D Printing could increase entrepreneurial behavior in community college students, which could support the economic development of the areas that community colleges serve.

Third, 3D Printing is a fun, multidisciplinary activity that provides a platform for collaboration across disciplines. Finally, 3D Printing is an open source technology that everyone can contribute to. Participants in the open source 3D Printing community could produce innovations that other individuals can deploy around the world. A community college, through execution and innovation in 3D Printing, could raise its public profile and STEM instructional reputation to the level of an MIT or regional technical school with concerted effort.

Traditional higher education STEM instruction supports the notion that students are successful if they are talented, well-prepared, and familiar with the academic coursework that they are pursuing (Leslie, Cimpian, Meyer, & Freeland, 2015). While it is true that prior success in STEM is the best indicator of future academic performance, it cannot be the only way that adults develop STEM acumen. Community college students, like many students in higher education, are not adequately prepared for college coursework when they arrive for their first years of instruction (Bettinger & Long, 2009). Community colleges are educational institutions where students who lack knowledge in crucial STEM disciplines should be able to gain that knowledge as a function of enrollment, although in some cases, they do not (Bailey, 2015).

All community college students should be presented with the opportunity to develop an identity as STEM practitioner. This research explored informal STEM-based activities that require no talent or prior knowledge to execute. If a community college student can develop a version of their possible selves as STEM practitioners, then that possible self can support the effort and dedication needed to complete coursework in the objectively challenging STEM curriculum (Markus & Nurius, 1986).

### **3D Printing in Higher Education**

3D Printing is a multidisciplinary technical pursuit that has demonstrated significant value to a host of industries for over 30 years (Ashley, 1995; Wohlers, 2016). The demonstrated value lies in the strengths of the 3D Printing process, which produces highly repeatable, infinitely complex, and customizable objects. This demonstrated value has been a game changer in a host of industries that include but are not limited to Automotive, Medical, Dental, Engineering, Architecture, and Manufacturing (Attaran & Stidham, 2017). Higher education is among the industries that have yet to significantly benefit from the application of 3D Printing technology.

The pace of expansion of 3D Printing led to significant investment in the utilization of the 3D Printing machines (Caffrey & Wohlers, 2015). Furthermore, experts theorize that innovation and use of the technology would spawn significant changes in business and education.

For many, 3D Printing has created a new way of thinking and conducting business. It has become the genesis for fresh ideas and new business models. Also, it is leading to new types of education and training programs that offer hands-on learning, experimentation, creativity, and invention. Many individuals and organizations have launched new types of products, services, and businesses that were unimaginable 15 years ago. (Caffrey & Wohlers, 2015, p.78)

3D printers have been used to fabricate fluid dynamics simulators which help demonstrate the characteristics of microfluidic behaviors (Morgan et al., 2016) Scanning and printing technology has also been used to simulate cerebral internal vascular anatomy to support brain surgery preparation (Vakharia, Vakharia, & Hill, 2016). 3D printers are used as an extension of library services to enhance higher education instruction. 3D printers are also used to make digital terrain

models that provide haptic information for visually impaired students (Horowitz & Schultz, 2014). The body of research on 3D Printing examines the impact that the technology has on instruction through enhancements to an existing curriculum or extracurricular engagement. However, the research falls short on examining the influence that student-centered 3D Printing has on students, particularly in the community college setting.

The available research on 3D Printing in educational settings yields results that suggest that students benefit from engaging in 3D Printing as an integral part of instruction. In 2017, Kwon conducted a study of high school students that emphasized the use and mastery of 3D Printing software. The students went through eight days of 3D software training, at the end of the training, they were able to demonstrate greater mathematical skills and were more motivated to learn (Y. Kwon, Lee, & Kim, 2017). In a study that examined the impact of 3D Printing on Social Science instruction in high school, Maloy (2017) found that 3D Printing supported Social Science instruction provides a framework for more engaged and active learning.

Further research on 3D Printing in higher education emphasizes the idea that the delivery method of technical learning experiences is as important as the subject matter itself. A 2016 study examined the impact that 3D Printing and robotic programming would have on college student's motivation to learn and apply robotic concepts (Armesto, Fuentes-Durá, & Perry, 2016). The results of the study produced evidence that suggests that students who used 3D Printing and built their own robots reported greater satisfaction with the instruction. The students who 3D printed their own robots also reported that they had an easier time integrating the learning from robotics into wider systems than students who used pre-fabricated robots (Armesto et al., 2016). These findings are consistent with a wider body of research on STEM engagement in higher education. Studies that examine the influence of STEM integration in higher education

contain information to support the notion that new instructional perspectives and long term projects with sustained effort are the most highly correlated with generating an increased interest in STEM (Daniel, 2017a; Doerschuk, 2016; Finkel, 2017; Jen-Mei, Chuhee, Stevens, & Buonora, 2016; Wang, 2013a)

### **Conceptual Framework**

The dearth of students who graduate with degrees in the STEM fields who are first generation to college, low income, and under represented minorities comprise the first segment of the conceptual framework of this study (NSF, 2015). Community colleges are the institution of choice for under-represented minorities; half of the STEM jobs in the US require a 2-year degree (Rothwell, 2013). The results of this study have produced useful information about increasing the comfort level of community college students who have had limited exposure to STEM fields.

The conceptual framework of this study explores the versions of possible selves of community college students when they engage in informal hands-on STEM-based activities. Higher education is the place where students come to earn the credentials that will allow them to work professionally in the STEM fields. Often, the students who earn these credentials already have previous experience and confidence in the study of STEM (Wang, 2013b, 2013c). They build on existing skillsets by enrolling in college courses to increase their expertise and receive a credential that will qualify them for a STEM-related occupation (Kolko, Hope, Sattler, Maccorkle, & Sirjani, 2012; Wang, 2013a). The students with previous STEM acumen were not the primary focus of this study; statistically, there are too few women and under-represented minorities in this pool to move the STEM professional "diversity needle."

The way students learn in higher education is mainly through lectured instruction and formal evaluation of the presented information. However, STEM pursuits do not always lend themselves to traditional instruction modes of delivery; it is possible that the number of STEM graduates will not increase in diversity through traditional means alone (Papavlasopoulou, Giannakos, & Jaccheri, 2017). 3D Printing allows practitioners to be engaged learners who have control over their subject matter (Papavlasopoulou et al., 2017; Yi-Hsuen & Min, 2007).

Problem-based learning (PBL) was the third segment of the conceptual framework of this study. Problem-based learning is a tool for communicating STEM-based ideas and concepts within relatable scenarios. Studies of PBL approaches to computer programming present evidence to support the notion that novices benefit from learning the schemas of computer programming without the unnecessary burden of syntax (Mason & Cooper, 2013). 3D Printing requires no programming or syntax expertise to be practiced effectively.

The self-reported dynamics on expected, future, and feared possible selves of students who engage in 3D Printing are a tool to formulate practices to engage students from diverse backgrounds in higher paying STEM fields. This study was intended to extend the understanding of student acquisition of technological skills and interest in design, coding, and problem solving, the three critical disciplines that facilitate entry into technical professions.

### **Research Questions**

The purpose of this qualitative case study was to gather the self-reported description of past, expected, and future possible selves of community college students who engage in sustained, collaborative, and purposeful 3D Printing. The proposed study answered the research questions:

Research Question 1: How do community college students describe their possible selves while engaging in the informal practice of 3D Printing?

Research Question 2: How do students with established possible selves navigate the educational infrastructure and pedagogy to secure resources necessary to support their possible self?

### **Significance of the Study**

The information derived from soliciting data about the possible selves of students who engage in 3D Printing will be useful in the process of recruiting and graduating more students from diverse backgrounds with Associates degrees in STEM fields. This study extended the understanding of student acquisition of technological skills in design, coding, and problem solving, three critical skills that provide entry into high paying technical professions. The results of this study have produced information about STEM ideation and self-identification in community college students who have yet to develop them. It is possible that 3D Printing could support an increase in the number of students electing to be STEM majors. Increasing the number of students who are interested in STEM is critically important; the rate of African American and Hispanic community college students who graduate with Associates Degrees in Engineering is unacceptably low. There are 6.2 million students enrolled in public community colleges in the US in 2016, 854,000 of whom are African American, and 1,489,800 of whom are Hispanic (National Center for Education et al., 2016). From the pool of enrolled students in community college. The total number of Hispanic and Black students who graduated with Associates Degrees in Engineering in 2015 was 1,017 graduates this number represents four one-hundredths of a percent (.04%) of the total Hispanic and Black community college enrolled population (NSF, 2015).

## **Overview of Methodology**

The researcher has used a qualitative collective case study design to record the dynamics of the possible selves of community college students over a 12-week period using 3D Printing activities as the catalyst. This qualitative case study used a series of individual interviews, recorded documentation, and naturalistic observation to solicit descriptions of student possible selves. Study participants were students who engage in 3D Printing at a community college in the Southeast United States.

## **Delimitations**

Participants in the study were students who expressed an interest in and engaged in informal learning activities at a community college. The period of time that that participation took place was over a 12-week period. Participants were recruited through a combination of student outreach during campus club fairs, social media, video, and print media flyers, which were distributed on campus. Participants were over the age of 18 and were engaged in a minimum of 6 informal learning activities over the course of the 12-week study period.

## **Definition of Key Terms**

This dissertation used the following definitions for key terms in 3D Printing:

*additive manufacturing (AM)* – the process of joining materials to make parts from 3D model data, usually layer upon layer

*material extrusion* – additive manufacturing process in which material is selectively dispensed through a nozzle or orifice

*fused deposition modeling or fused filament fabrication* – a process that takes place when an end user loads a digital file called a stereolithograph into a computer driven machine called a 3D printer. When the 3D printer obeys the commands contained in the STL file, it carries out a



series of steps that result in the computer driven machine making a 3-dimensional object that has height, width, volume, and density. 3D printers are capable of producing any number of objects using low cost and open source instructions and files (Jones et al., 2011).

*knowledge based stratification* – a formal or informal social order that identifies individuals who have knowledge as more valuable to academic, social, and technical pursuits

*long-term project* – a project that requires at least two weeks of sustained effort in order to complete.

*stereolithograph (STL)* – file format for model data describing the surface geometry of an object as a tessellation of triangles used to communicate 3D geometries to machines in order to build physical parts.

*Technological affinity* – The amount that a person expresses a natural liking for technology and technology processes. Particularly as they relate to academic subjects.

*CCBTWC* – community college of Booker T. Washington County

This dissertation will use the following definitions for key terms in the research literature on possible selves:

*possible selves* – a part of the self-concept that is seeded around images of the self from the past and present. The possible selves are malleable because they are influenced by experiences that confirm or refute a past, expected, and future elements of self concept.

*hoped for self* – a future version of a possible self that is a source of hope, a vision of a life that is to be achieved

*expected self* – a version of the possible self that is representative of the current conditions and possibilities no farther than six months into the future

*past self* – a version of the possible self that identifies significant characteristics that may be applicable to the present self-concept

*feared self* – a version of the possible self that is feared if goals are not attained or if the hoped-for self is not achieved

### **Chapter Summary**

3D Printing is a STEM-based hands-on practice that allows computer-controlled machines to process a CAD drawing and convert it into a physical object. 3D Printing is practiced in the medical, automotive, dental, manufacturing, aerospace, engineering, architectural, and educational industries. The educational application of 3D Printing is closely related to research and development in post-secondary education. In elementary through secondary education, 3D Printing is used as a tool to engage learners through structured long-term informal education. The results of the engaged learning indicate that applying 3D Printing to informal learning settings is an effective strategy for greater student engagement. The methodology in this study was designed to stimulate reported impressions on self-identity during long-term informal learning that is facilitated by 3D Printing. In chapter two, a literature review on the progression of the concepts that developed to institute the subject matter of this study are examined. In chapter 3, the conceptual framework and methodology of the study are explored to lend a greater understanding of the data collection methods. In chapter 4, the results of the study will be reported. In chapter 5, the implications of the results will be discussed to frame future directions for education and 3D Printing technology.

## **CHAPTER 2**

### **LITERATURE REVIEW**

The current chapter is designed to help the reader understand the problem of low graduation and participation rates of STEM majors in community colleges and provide a framework to view them. The chapter outlines the trends of STEM graduation rates for students from diverse backgrounds and women in community college. It moves on to discuss important aspects of informal education, examine post-phenomenology as a lens to view human interaction with technology, and frame the subject matter of 3D Printing within a problem-based learning paradigm.

#### **Graduation Rates of Community College STEM Programs**

The US community college system is an instructional provider for more than half of all women and students from diverse backgrounds who enter the STEM fields (National Center for Education & Institute of Education, 2019). There are 6.2 million students enrolled in public community colleges in the US, 788,800 of whom are African American, and 1,439,100 of whom are Hispanic (National Center for Education & Institute of Education, 2019).

Given the number of students who are enrolled in community college, and the statistical significance of the standard deviation curve, 2.15 percent of the community college population has an IQ above 120 points, a score that places them at least two standard deviations above the mean (Sprinthall, 2012). That number represents 16,959 African American and 30,940 Hispanic community college students nationwide (National Center for Education et al., 2016; Sprinthall, 2012). There are over 50,000 students from diverse backgrounds who are statistically intelligent enough to comprehend the material that comprises an Engineering Associates Degree program. The number of African American students who were granted Associates of Science in

Engineering in 2017 was 424, just .053 percent of the total African American community college population. The number of Hispanic students who granted associates of science in Engineering was 994, just .069 percent of the total enrolled Hispanic Population (National Center for Education & Institute of Education, 2019).

In 2014, the National Science Foundation produced a report on the gender distribution of STEM related degrees across higher education. The distribution across genders for Engineering was skewed heavily in favor of male students (NSF, 2015). Twelve (12) percent of all of the Associates of Science in Engineering degrees conferred upon African American students went to women, and fifteen (15) percent of the Hispanic students with the same degree were women (NSF, 2015).

Computer science is another STEM-based field that provides students with rewarding and well-paying careers after graduation. The number of students from diverse backgrounds that are enrolled in Computer Science coursework and the gender imbalance found in that population draws a series of parallels with Engineering. Once again, there are 788,800 African American and 1,439,100 Hispanic students enrolled in community college in the US (National Center for Education & Institute of Education, 2019).

The number of African American students who graduated with Associate of Science in Computer Science in 2017 was 4161 or .52 percent of the total African American community college population (National Center for Education & Institute of Education, 2019). The number of Hispanic students with degrees in the same field of study was .26 percent of the total enrolled Hispanic community college population (National Center for Education & Institute of Education, 2019). According to the 2014 report on STEM enrollment by the National Science Foundation, the gender balance of the students who were conferred Associates Degrees in Computer science

was 26 percent female for the African American population and 19 percent for the Hispanic population (NSF, 2015). The poor gender balance and the extraordinarily small number of degrees that are awarded to Hispanic and African American students in computer science and Engineering presents a series of opportunities. These opportunities orbit around the shortfall of STEM participation and create the occasion to make observations about the mechanisms driving community college student gravitation toward or away from these fields.

### **3D Printing at Community Colleges**

There are 13.75 million students enrolled in degree-granting 4-year higher education institutions, and 6.2 million students attending two-year public community colleges in the US (National Center for Education & Institute of Education, 2019). The proportion of 4-year institutional enrollment compared to 2-year institutional enrollment does not reflect in the body of research on informal education in higher education. A literature review of academic research around the maker movement yielded 43 peer-reviewed articles (Papavlasopoulou et al., 2017). The settings listed in the peer-reviewed articles included four-year colleges and universities, local makerspaces, summer camps, and temporary community locations, there was not a single explicit mention of a community college in Papavlasopoulou's (2017) academic literature review. Research in the field of informal 3D Printing instruction, digital fabrication, micro-controller programming, and robotics is not proportionally represented in community colleges (Birtchnell, Böhme, & Gorkin, 2017; H. Kwon, 2017; Maloy et al., 2017; Papavlasopoulou et al., 2017; C. Smith & Wingate, 2016a; Trust & Maloy, 2018)

### **STEM Degrees at Community Colleges by Field**

The anemic proportions of female and underrepresented minority Associate Degree conferees in computer science and engineering are not universal across the STEM fields. For

example, applied science related STEM fields excel in graduating students from diverse backgrounds (NSF, 2015, 2017). The number of Latino students graduating with an Associate's of Applied Engineering in 2014 was 4,514, 2.8 percent of the Latino student population, and 3,943, 2.4 percent of the Black student population (NSF, 2015). The Biology related technical degrees, which are inclusive of Nursing and Allied Health training, have distinguished rates of graduation as well (NSF, 2015). 9.8 percent of the Latino student population and 9.0 percent of the Black student population graduated with a Biology related applied associates in 2014 (NSF, 2015).

It is important to note that the number of Biology related associates degree holders is possibly the best indication that female, first generation, Black, and Hispanic students could be persuaded into taking and passing the course requirements for degrees in computer science, math, or engineering (Hachey, Conway, & Wladis, 2013; NSF, 2015). The proposed method of persuasion is 3D Printing, a hands-on STEM-based pursuit. The bright Female, Hispanic, and African American minds that populate the community college student body could discover that they are capable of being successful engineers and computer scientists, through engaging in the practice.

### **Barriers in STEM Education**

Research into the exploration of student success and retention in Science Technology Engineering and Math (STEM) reveals a set of dynamics that outline inherent barriers within STEM education. This discussion will center around four obstacles or negative influences on community college student success in STEM coursework. These influences are relatability of the STEM curriculum, Intelligence Paradigm barriers, social/global aspects of the STEM participation, and informal education.

### **Relatability of the STEM Curriculum**

Qualitative studies of students who change their major from STEM to other academic disciplines cite the fact that they did not see how the subject matter related to their personal lives as a significant factor in changing their major (Chrstidou, 2011). Other studies of the reasons why engineering students switch majors cited unapproachable faculty, complicated curriculum, and poor advising (Meyer, 2014). Furthermore, students who left undergraduate engineering programs of study reported that they were not ready for the exceptional amount of difficulty that the engineering curriculum contained. Specifically, they reported that they had no idea how much work the degree would take, and how many hours of homework were required to keep their heads above water. The findings for Meyer's (2014) study resonate with other studies that examined the culture of student and faculty interaction in STEM academic departments (Duncan, 2005). These findings are important because just one of the significant cited reasons for leaving the engineering major was inherent in the study of engineering, the amount of work. The other significant factors can be controlled or influenced through administrative and instructional prioritization.

### **Intelligence Paradigm Barriers**

There is evidence to support the idea the success rates of students in STEM fields are subject to academic paradigms about the true nature of intelligence. For this discussion, there are two crucial paradigms to consider, entity or stable intellectual ability versus incremental or malleable intellectual ability. The entity paradigm of ability holds that individuals are born with a specific amount of ability, intelligence, or talent that is attributed to their academic performance. The level of an individual's ability is stable and is ascertained from early feedback and assessment. Conversely, the incremental paradigm of ability holds that an individual's

intelligence or talent is malleable over time; people can learn skills, improve abilities, and also lose skills or be less proficient as well. (Rattan et al., 2012)

The entity versus incremental paradigms is relevant to the conversation about student success rates in academic STEM pursuits. The results of a study conducted by Rattan et al. (2012) at a highly competitive university supported the notion that identification with the entity paradigm of ability in undergraduate students results in lower academic expectations. The study by Rattan et al. (2012) presented graduate mathematics instructors with scripts that described students who were struggling in mathematics course assessments. The graduate instructors who identified with the entity paradigm of intelligence choose dismissive or discouraging patterns of interaction with struggling students significantly more than the instructors who identified with the incremental paradigm (Rattan et al., 2012).

An entity perspective of ability is negatively correlated with the number of female Doctoral Degree holders in a field of study as well (Leslie et al., 2015). In their study, Leslie et al. (2015) found evidence to support the idea that academic pursuits that centralize raw talent as a requirement for success are also biased against women. The fields of Math, Computer Science, and Physics have the highest ideation of talent as central to success and also the lowest percentage of female Ph. D.s (Leslie et al., 2015).

The results of studies about entity versus incremental intelligence paradigms are important; they help to frame the success rates of students in community colleges settings, particularly when examining the paradigm of previous experience in STEM disciplines, students who enroll in and persist in STEM coursework at two-year colleges typically have more years of math education in high school than those who do not (Wang, 2013a). Previous experience in



math is an important success factor in higher education, but so is motivation, and self-perception (Fong et al., 2017).

### **Social and Global Aspects of STEM Participation**

There are instances of successful programs that seek to enhance student and faculty interaction in STEM pursuits. The National Science Foundation (NSF) Science Technology and Mathematics Talent Expansion Program (STEP) is a tool that has been used to increase the number of students enrolled in STEM-based curriculum in community colleges (Caplan & MacLachlan, 2014). The Queens community college (QCC) campus of the City University of New York (CUNY) system, was awarded a STEP grant which funded efforts that produced promising results (Caplan & MacLachlan, 2014). The QCC program employed community college students as research assistants (Caplan & MacLachlan, 2014). The program was reported to have an extremely high rate of transfer of QCC students to 4-year universities. (Caplan & MacLachlan, 2014).

Another iteration of a program funded by the NSF STEP program took place at the University of Memphis. The University of Memphis' five-year talent expansion program was called MemphiSTEP (Windsor et al., 2015). The MemphiSTEP program focused on increasing the number of STEM majors at the institution. It incorporated a number of interventions to achieve that goal (Windsor et al., 2015). MemphiSTEP employed a Summer Mathematics Bridge Bootcamp, a networking program, an undergraduate research program, a travel award program and a STEM learning community (Windsor et al., 2015). The program was credited with increasing the number of STEM majors by 60 percent at University of Memphis over an eight year period of measurement (Windsor et al., 2015).

The University of Oregon and six community colleges in the State of Washington also used the NSF STEP program to increase enrollment in STEM-based curriculum. The Undergraduate Catalytic Outreach and Research Program (UCORE) selected 20 to 30 students per year to come to the University of Oregon to be research fellows during a 10-week summer residency (Strawn & Livelybrooks, 2012). The students who participated in the program were selected on the basis of first-generation to college, underrepresented group status, math preparation, and evidence of persistence or “grit” (Strawn & Livelybrooks, 2012). Analysis of the rates of transfer and graduation of the students in the UCORE program yielded results that indicated that UCORE students were five times more likely to transfer to university over a comparison group, which was controlled for gender GPA, first-generation, and minority status (Strawn, 2010).

The examples from the University of Oregon, University of Memphis, and CUNY system make use of several important practices that can be repeated. These programs and other research on the subject emphasize academic preparation, personal motivation, social support, academic support, and affordability in their interventions (C. Smith & Wingate, 2016b). These are factors that are not inherently related to the actual STEM curriculum, Smith and Wingate (2016) suggest that fostering a welcoming environment within academic departments combined with a series of financial supports that include research assistantships and on-campus employment as tools for supporting student success in STEM at two-year colleges. The concept of a welcoming environment as a positive influence on student success is supported by other researchers and reported results from the NIH and the NSF grant programs (Caplan & MacLachlan, 2014; Chan & Wang, 2016; Finkel, 2017; Martin, 2014; Strawn & Livelybrooks, 2012; Windsor et al., 2015).

Studies that measure the success of STEM student retention and motivation programs reveal a holistic approach. Instances of successful STEM retention programs deploy paid internships or stipends for student participation. They also include a component of faculty mentoring, and community engagement that employs college students as STEM camp instructors, high school outreach agents, and service learners (Daniel, 2017b; Doerschuk, 2016; Jen-Mei et al., 2016). The programs that are designed to increase STEM student success holistically are typically funded by third party non-profits, government agencies, and time-limited grant money, none of which are universally scalable (Daniel, 2017b; Melguizo & Wolniak, 2011; C. Smith & Wingate, 2016b).

In studies that approached STEM retention and success through less expensive and scalable approaches, there is evidence to support the notion that an institution can increase student success through some modest changes in institutional culture (Kerrigan, 2015). One analysis of community college faculty culture revolved around social capital in support of student success. Social capital is a measure of the amount of benefit or goodwill that a person can command as a result of their personal interactions (Kerrigan, 2015). Kerrigan's study surveyed the administration and instructors at 41 different colleges about their interactions and conversations about student success. The survey results indicated that academic departments that met about and discussed student success in an organized setting more than once a year self-reported using student success statistics more frequently (Kerrigan, 2015). Using student success statistics in departmental discussions and professional development translates into the social capital needed to support greater student success (Kerrigan, 2015).

There is a significant amount of research on STEM participation in higher education that emphasizes top-down complex systems and partnerships between educational institutions and

funding agencies in the form of private, state, or federal funding. There is less research on student-led open access utilization of technology for the purpose of supporting retention and enrollment in STEM curriculum. Each of the three programs cited in this dissertation requires students to prove or vet themselves to the institution in order to qualify to participate in research or residencies. An interesting conversation can be started in higher education about the value of making STEM attractive to students through activities that are unique, interesting, decentralized, and low cost.

### **Informal Education**

Informal education can be understood as learning that is delivered through voluntary, ongoing, personalized, open-ended, and learner motivated means (Council, 2009; Kim & Dopico, 2016). In the past, informal learning settings took the form of libraries, churches, and museums, which fostered exploration, communication, and access for members of the public (Council, 2009). The historical progression of informal education travels through the emergence of Lyceums in the early 1800s through to The World's Fairs of the early 20th century (Council, 2009). Informal education settings across time were platforms for exploring the world of science through testing, exploring, predicting, questioning, and observing the natural and physical world (Council, 2009; Kim & Dopico, 2016).

In modern-day settings, museums and makerspaces facilitate the reflection on science and provide platforms to participate in scientific activities to members of the public (Honma, 2017). They also facilitate the development of student identities as scientific practitioners who contribute to, are knowledgeable about, and use science for discovery (Council, 2009). Finally, informal education settings and makerspaces are platforms that provide non-traditional support for the higher education mission (Honma, 2017). For example, modern-day science museums are

obligated to provide an experience that speaks to a more gender equitable, and diverse audience in order to be financially sustainable and relevant (Archer, Dawson, Seakins, & Wong, 2016; Feinstein, 2017; Rameygassert, 1996).

The modern makerspace is a hotspot of activity, lending itself to self-directed learning that aligns with the mission of higher education in several ways (Dubriwny, Pritchett, Hardesty, & Hellman, 2016; Papavlasopoulou et al., 2017). Makerspaces provide an alternative entry pathway to the formal study of science and technology for curious and non-traditional students (Honma, 2017). Research provides evidence to support the notion that the strong identity that results from the informal practice of STEM is utilitarian in the instruction, attraction, and retention of STEM students in higher education (Jackson & Seiler, 2017; Papavlasopoulou et al., 2017). Other results suggest that a strong STEM identity that is cultivated through informal STEM practice provides students with a significant degree of durability and tolerance for logistical and academic setbacks (Jackson & Seiler, 2013, 2017).

### **Framing STEM in Community colleges**

#### **Problem and Project Based Learning**

Interventions and coursework that promote informal communication, and make STEM subject matter more relatable are commonplace in Problem/Project Based Learning (PBL) designs in education (Wallace & Webb, 2016). Problem-based learning instruction is delivered through a series of loosely structured problems that stimulate the learner to find out what knowledge they have and what knowledge they need in order to produce a solution (Craft & Mack, 2001; Wallace & Webb, 2016). Problem-based learning fosters close cooperation between students, and greater individualized communication between faculty/students which facilitates

valuable, low stakes feedback (Craft & Mack, 2001; Jacques, Bissey, & Martin, 2016; McGivney-Burelle & Xue, 2013; Wallace & Webb, 2016).

The benefits of PBL in engineering coursework produce observable differences for faculty and students, as reported by qualitative studies (Wallace & Webb, 2016). Studies that examine Problem-based learning in higher education report several benefits to students in STEM coursework. First, students who engage in a problem-based curriculum in the South Carolina Technical Education System sustained a higher than average enrollment retention rate (Craft & Mack, 2001). A study of undergraduate students at the Georgia Institute of Technology presented findings that indicate using problem-solving skills contributes to a greater understanding of engineering concepts (Le Doux & Waller, 2016). The results of research on Problem-based learning presents evidence to suggest that deploying 3D Printing as an informal education platform, could support higher enrollment in STEM coursework and academic inquiry in the community college setting (Craft & Mack, 2001; Le Doux & Waller, 2016).

### **Postphenomenology**

It is crucial to consider the interactions of humans with technology, a major tenant of a post-phenomenological inquiry when examining the questions associated with deploying 3D Printing and its potential effects on the community college students (Aagaard, 2017). Post-phenomenology holds that technologies are objects that humans use to extend their perceptions or abilities (Tripathi, 2016). With each technological development, human experience is transformed or mediated through objects (Tripathi, 2016). For example, an arrow is an extension of human speed; it travels faster than humanly possible in the pursuit of prey. The club is harder and more durable than human flesh; it can break a greater range of hard objects. Finally, the computer can memorize and process information faster than the human brain can on its own

(Tripathi, 2016). A 3D printer is an object that can produce highly customized, repeatable objects in a short time frame with no regards for commercial viability, and at an insignificant cost of production, (Birtchnell, 2016; Jones et al., 2011). A literature review of postphenomenology did not yield any research that considered the human and technology interaction of 3D Printing.

Postphenomenology frames the human and technology interaction as a two-way street: "In the case of technologies, for example, humans may "invent" technologies, but in use, all technologies also "re-invent" humans." (Tripathi, 2016, p. 238). For example, wireless technology and cellphones have influenced the degree to which students can pay attention during class instruction (Aagaard, 2015). In the instance of industrial designers, wearable simulations illustrate the "re-invention" dynamic acutely. Industrial designers typically use restrictive gloves and goggles that occlude peripheral vision to simulate the experience of elderly users. The simulations are a technology that designers use and they have a tendency to create a monolith of experience rather than a recapitulation of user challenges (Kullman, 2016). The position that post-phenomenology presents is that the designer is not gaining empathy for the end user; instead he or she is learning how to get along in the world while being subject to the technology of the simulations (Kullman, 2016). The designer's perceptions through the simulation hardware potentially support the false premise that there is a perfect solution for people with arthritis or cataracts, which can lead to incorrect, incomplete, or unnecessary accommodation designs (Kullman, 2016).

Competitive video gaming presents another example of how technology interactions impact humans (Ash, 2012). Popular fighting video games produce conditions that require humans to react to gameplay input within 1/6th, 1/12th, or 1/60th of a second, units of time that are imperceptible to the human brain (Ash, 2012). Interactions with these video games can

produce new ways of thinking about time. Elite players in a qualitative study report developing a process of predicting gameplay versus reacting to the moves of their opponents in real time (Ash, 2012).

When a piece of technology can create meaning for the user in several ways, it is exhibiting multistability (Aagaard, 2015, 2017; Kullman, 2016). Multistability is another essential concept of post-phenomenological inquiry (Aagaard, 2015, 2017). The examples of the concept are embodied in the three previously mentioned technologies the arrow, club, and computer. Each of these technologies has an intended use: hunting, cracking/crushing, and computing. Each of these technologies is also used in the execution of warfare, violence, sport, and entertainment as well. There is a myriad of different uses of technology throughout human history. Post-phenomenology holds that the user defines the utility, and the technology effectively (or ineffectively) executes the use (Aagaard, 2015).

3D printers can potentially help students learn about computer science, engineering, design, and robotics; the platform allows for learning and reflection in any number of ways. The multiple legitimate ways that students interact with 3D printers are important for describing the potential benefits of 3D Printing practice to community college students (Tripathi, 2016). Currently, there is no singular, widely held, or specifically, appropriate use for 3D printers, the technology is arguably flexibility built upon flexibility. A post phenomenological viewpoint can give the body of research on 3D Printing perspective into its impact on community college learners.

### **Possible Selves**

Possible selves is the label that is given to individually significant representations of the self that encompass hopes, fears, and dreams (Markus & Nurius, 1986). What a person can or



aspires to become- the “hoped for selves,” what a person could or is likely to become – the “expected selves” and what a person fears – the “feared selves” are the three substantial components of the theory (Markus & Nurius, 1986). The Possible Selves Theory is the conceptual framework of this study.

Changes or differences in the composition of reported possible selves can indicate significant dynamics in student development (Ozaki, 2016; Roshandel & Hudley, 2018; Stevenson & Clegg, 2011; Yowell, 2002). Possible selves frames personal development as the process of acquiring and accepting or rejecting different versions of possible selves over time (Markus & Nurius, 1986). Community college students are presented with a myriad of competing possible selves; parent, wage earner, caretaker, and college student (Ozaki, 2016). Research on possible selves indicates that even when community college students stop enrolling for reasons other than academic ones, a possible self that identifies as a college student is sighted as a justification for returning to complete degree coursework (Ozaki, 2016). The possible selves body of research also supports the notion that extra-curricular activity influences the development of possible selves. (Stevenson & Clegg, 2011)

Possible selves is a dynamic and exciting concept to apply to the community college experience. First of all, the theory allows individuals the ability to choose or change their dominant possible self-predicated on what is important at the time (Ozaki, 2016). Second, it will enable a person to take any experience and use that experience to develop a possible self through avoidance of a feared outcome and progression towards a desired one (Oyserman, Bybee, Terry, & Hart-Johnson, 2004). The concept of possible selves depends heavily on the individual bringing a set of fears, expectations, and hopes to the study setting, providing the subjects with

an experience, and then measuring the success of that experience against the developed possible selves of the subjects (Lee et al., 2015; Oyserman et al., 2004).

### **Chapter Summary**

The literature review presents an examination of the germane aspects of college success rates, research in community colleges, and informal STEM instruction. It also illustrates problem/project-based learning and the framework of post-phenomenology for understanding the interaction between human and 3D Printing technology. The review is intended to highlight the ideas that help the reader understand that 3D Printing can be connected to many aspects of the community college mission. As a tool for learning, 3D Printing is still developing a practical and academic identity. 3D Printing has yet to be embraced as a tool for instruction to any significant degree at the community college level. As a hands-on STEM-based pursuit, 3D Printing is a platform for interactive machining and development of a level of technological familiarity that is important in the sustained and successful study of STEM fields (Kim & Dopico, 2016).

The following chapter is an illustration of the methodology that was employed to examine the process of community college students engaging in 3D Printing. The next chapter illustrates the methods for gathering data about the possible self dynamics of community college students engaged in 3D Printing in informal settings.

## Chapter 3

### METHODOLOGY

The following is a description of the methodology that was undertaken to study how community college students described their possible selves while engaging in the informal practice of 3D Printing. The questions that the methodology addressed are:

Research Question 1. How would community college students describe their possible selves while engaging in the informal practice of 3D Printing?

Research Question 2: How do students with established possible selves navigate the educational infrastructure and pedagogy to secure resources necessary to support their possible self identity?

This chapter will describe the research paradigm and the method of data collection that was used to gather information about the study participants' experience. The sections of this chapter are an overview of the executed research methods, a description of the site, the eligible participants, the data collection method, the measures that were taken to protect the privacy of the participants and the process that were undertaken to ensure a fair, accurate and collaborative data analysis.

#### **Research Methods**

A minimum of 12 participants engaged in at least six sessions of 3D Printing activities connected to a community college in the Southeast US, The community college of Booker T. Washington County (CCBTWC). Data was gathered through two different methods to construct a trustworthy study. The first phase of data collection took place was when the students first engaged with the 3D Printing lab. This was the initial interview. The initial interview contained general engagement questions designed to gather significant information about any possible selves: past, expected, and future that were applicable during the time of the interview (Markus & Nurius, 1986). After the initial interview, the students 3D printed objects in the lab for

personal, academic, or extra-curricular purposes. Restated, they had experienced the 3D Printing Club programming and used the lab as it was designed. After they engaged in a minimum of six 3D Printing activities, students were interviewed again to gather data through semi-structured interviews. In the second interview, the students described their possible selves while engaging in 3D Printing.

The second type of data collected were documents, which included digital files, journaled entries, and photographic records of objects and events. The objects that the students printed, the projects that they attempted, and the lessons learned along the way were reviewed in the second interview. Photographs, journaled observations, and project histories were used to help construct the conversation around each student's participation in the 3D Printing programming.

The interview conversations were recorded in written transcripts; the transcripts of the conversations were scanned for manifest or directly observable phenomenon (Hays, 2012). The phenomenon were descriptive coded according to phrases in the first wave of data analysis (Hays, 2012). The first wave of data were secondarily coded in a thematic analysis to establish a pattern of observable behaviors and experiences (Saldaña, 2013).

### **Research Questions**

The research questions this study seeks to explore are:

Research Question 1: How do community college students describe their possible selves while engaging in the informal practice of 3D Printing?

Research Question 2: How do students with established possible selves navigate the educational infrastructure and pedagogy to secure resources necessary to support their possible self identity?

## **Critical Constructivism**

Critical constructivism was a crucial worldview to examine the dynamics of Community College student possible self development. Critical constructivism asserts that students are active producers of knowledge rather than passive receivers of knowledge transmitted through instructors to the individuals learning in the institution (Kincheloe, 2005). The exceptional utility of the theory allows researchers to assess the experience of students as they relate to power dynamics that operate to include or exclude individuals at many levels of education (Kincheloe, 2005). Specifically, the worldview provides a way to understand the process of knowledge creation inside the mind of the learner and how power dynamics influence the learning process (Kincheloe, 2005).

Critical constructivism was the worldview of this study because of the importance of the student/learner's identity. Students who are identified as Underrepresented Minorities are not graduating with degrees in STEM at a rate that meets the needs of the United States Workforce. Community Colleges are the institution of choice for students from diverse backgrounds and women (Hoffman, Starobin, Laanan, & Rivera, 2010). Despite these facts, there are too few URM students who graduate from community colleges with Computer Science or Engineering Associates of Science degrees, although that is a statistical certainty that there are enough students that are talented enough to do so (National Center for Education & Institute of Education, 2019).

Further important aspects of critical constructivism are the critical interpretation of the essential social and historical nature of making knowledge and forming thought called hermeneutics (Steinberg & Kincheloe, 2010). In the critical constructivist framework, hermeneutics embodies the dynamic understanding of how human beings make sense of the world (Kincheloe, 2005). How meaning is made in the individual is influenced by power

dynamics, the meaning that the individual engages in cannot be separated from their place in society (Kincheloe, 2005).

Finally, critical constructivism is central to this study because it allows the researcher to acknowledge that research is not neutral. When a researcher asserts that he or she is neutral, they allow the status quo to dominate aspects of their study (Kincheloe, 2005). The dynamics of the objectivity of this study will be discussed later in the methodology section of this work.

### **Participants**

The participants in this case study were members of a maker community. There were several types of participants who engaged in the practice of 3D Printing. The first type was 3D Printing technicians. These students worked in the 3D Printing lab as a function of their job responsibilities. The 3D Printing technicians were work-study students who qualified for the Federal Financial Aid work-study program. The selection criteria for the technicians was predicated on student interest; students were recruited to be 3D Printing technicians through their college's financial aid job announcement website. Students were interviewed, assessed for their availability and interest to work in the lab, and there was no minimum experience requirement to qualify to be a 3D Printing technician. The most valuable qualities for hiring were the willingness to learn and an ability to work with hand tools such as screwdrivers, hexagonal wrenches, and soldering irons.

The second type of study participants were student members of the 3D Printing and Robotics Club or 3D PARC. The 3D PARC was a student group that had an element of varsity robotics, 3D Printing, making, and computer programming. Some members of 3D PARC competed nationwide in VEX robotics competitions, these students used the 3D Printing lab to produce accessories and small components for VEX robots. Other activities that students in 3D

PARC engaged in include a Women in STEM panel discussion, Community tabling at local education forums, a 3D printed Christmas Ornament Exchange, and a hackathon. Tabling happened when members of 3D PARC setup tables, 3D Printing machines, and promotional materials in order to promote the activities of the group and gain membership. Furthermore, 3D PARC members engaged in intramural technological competitions called Micro-mouse in which a small robot is programmed to navigate a maze as fast as possible. Members of the 3D PARC, printed robotic platforms, assembled robots, and tested maze courses during meetings on campus. Finally, 3D PARC members contributed to departmental, campus-wide activities through the production of 3D printed objects and programming that was designed to support efforts such as STEM Week and Festival of the Arts across the institution.

The third type of participants that were eligible for this study were students who used the 3D Printing lab to support credit coursework. A select number of English, Math, and all of the Engineering courses on campus were supported through the 3D Printing lab. These students used the 3D Printing lab to produce course required models as well as extra credit submissions. Regardless of how they came to use the 3D Printing lab, the participants were part of the study as a function of their enrollment in community college and interest in 3D Printing. These students were the subjects of this study because the focus of the inquiry is on how community college students describe their possible selves after the practice of 3D Printing, the unifying or most common factor is being enrolled.

### **Site Description**

All of the participants in this study have worked in the same 3D Printing lab. The 3D Printing lab is a re-purposed academic space. The re-purposed space is housed at the Community College of Booker T. Washington County, a community college located in the southeastern part

of the U.S. with an enrollment of over 15,000 students. The space is approximately 500 square feet, and it used to be the smallest academic classroom on campus. The furniture in the lab, technician tables, and office chairs were diverted from government surplus sale. This means that an academic or administrative department on the campus deemed the furniture either unnecessary or outdated. Due to their condition, the college had resolved to sell them at auction. The furniture items that populate the lab were not sold at auction. Instead, they were claimed and set to use in the 3D Printing lab.

There were several 3D printers in the lab. All of the printers have been assembled by a person with little to no experience assembling 3D electronics. Furthermore, the space was home to several robotic projects at various stages. Partially built robots partially disassembled 3D printers, and parts from other electronics all found themselves in the setting. The computers that were used in the lab were a combination of desktop computers that have been diverted from government surplus sale, as well as upgraded computers that were electronic waste.

The electronic waste computers were disassembled by community college students who purged and tested the hardware for salvageable components. The salvageable components were assembled subsequently into two desktop computer stations. The 3D Printing lab that was the setting for this study was not a high-tech, shiny, brand new facility that was optimal for visiting state officials. Conversely, it is a space that was a bit disorganized, served multiple purposes and was an obvious student-centric location. The space was designed to be welcoming and inclusive as a room full of computerized equipment could possibly be.

Diverted surplus furniture and machines that were assembled by amateur hands are what give the lab the appearance of an accessible setting. The 3D Printing lab was a space where students are often pulled into collaborations on projects simply by being present. The room held



six people and the accompanying equipment comfortably. In a week, 20-40 people visited the lab to conduct their own initial investigation or to discover the lab. Students also visited to get help for a project or initiate their own activities that required 3D Printing. The lab also hosted visitors that are not college enrollees. On Saturdays, the lab supported a local STEM enrichment group that focused on providing exposure to middle school and high school students from diverse backgrounds to technology.

The 3D Printing lab directive is to be open and welcoming. 3D Printing technicians were instructed to be gracious and accommodating to anyone who walked through the door. New visitors were invited to join in on existing projects or have their open projects supported. The welcoming attitude of the technicians was a directive that is insisted upon by the researcher. All visitors were invited to "try," try to fix, try to make, try to diagnose, try to explore ideas, techniques, and upgrades, even if the hardware was put at risk. As long as no-one was placed in physical harm, made to feel unwelcome, or was inviting inactivity, all activities were sanctioned in the lab. This directive took precedence even if it meant inadvertent damage to hardware. Several control boards, print beds, power sources, fan shrouds, hot-ends, temperature sensors, and heat sources have been made unusable due to user error in the lab. The attitude of the researcher is this: things break, learn what broke it, fix it, and keep learning. Since the lab uses RepRap style machines, almost all of the parts of the 3D printers were interchangeable, and the process of repairing, commissioning, and operating had a potential effect on possible selves. Failure was a part of the overall experience.

### **Data Collection**

The processes and necessary steps that have been taken to collect the data for this study are described in the following section.

**Interviews.** The primary sources of data for this study were interviews and documents. The 3D Printing lab technicians and the 3D PARC leadership were aware of the research that was taking place. When new student lab users came to the 3D Printing lab, the researcher was to be notified; the researcher came to the lab in as many instances as possible and was introduced. After the introduction, the researcher explained the role of the 3D Printing lab and let new students initiate their projects. The researcher naturalistically observed the engagement of the new students in selecting and initiating a project. The naturalistic observations were recorded in a notebook with initial reflections of each student. Once a 3D model was picked and placed on a machine to be produced, the newcomer was invited to be a subject in the study.

Once the participant agreed to be a part of the study and the consent form had been explained and signed by the student, the first phase of data collection started. The first interview was an informal engagement that sought to gather data within an academic setting if preferred by the subjects; the interviews took place in a semi-private office or classroom where just the researcher and the subject were present. The information gathered centered on that the participant's current level of engagement in 3D Printing, what their current academic and extracurricular interests were and what brought them to into the lab. Other information gathered was centered on their level of identification with technology. The initial interview questions are listed in Appendix A.

The pool of initial subjects was narrowed down to twelve subjects that provided documentation and participated in the second phase of interviews after five additional sessions of 3D Printing programming. The subjects were selected according to how they first became involved in the lab; there were three 3D Printing technicians, six 3D PARC members, and three students who have fulfilled course requirements using the 3D Printing lab. The students who did

not see themselves as STEM people upon their initial interactions with the lab were placed as the highest priority for invitations for second interviews. Secondly, priority was placed on securing a balance of gender and ethnic diversity for second phase participants.

The second phase of interviews was more in-depth and conducted in semi-private academic settings. The second interview questions are provided in Appendix A. The second interviews focused on three phases of the possible selves of the study participants. The questions were designed to get information about the spectrum of the student's hoped-for selves, expected selves, and feared selves (Markus & Nurius, 1986). The interview stimulated hoped for, expected, and feared selves conversation by using a 3D Printing Infinity Gauntlet replica as a tie into the constructs. An example of a 3D Printing Infinity Gauntlet is in Appendix B.

Interview protocols were shaped by previous sessions with 3D Printing technicians and 3D PARC participants. The data that was collected for this study came from one on one interviews with 3D Printing technicians, the student participants in 3D PARC, and students who were using the lab to support credit coursework. The interviews were recorded on a password protected cellular phone. Interviews occurred while the students were having their 3D models printed, which took from forty-five minutes to fourteen hours. The interviews were semi-structured with questions based on possible selves research literature and post-phenomenology (Aagaard et al., 2018; Markus & Nurius, 1986; Seidman, 2013). The second interview subject matter was similar to the first interview; however, it was amended to include discussion of the 3D printed models that students produced collaboratively and individually.

**Documents and Artifacts.** Supplemental documents from each participant, including pictures of the 3D printed objects and the digital files that are used for 3D Printing the models, supplemented the research questions of the second interview. These documents were a

mechanism for gaining greater depth in the interview. The purpose of the documents was to provide supplemental interview data (Seidman, 2013).

### **Study Procedures**

The study was designed to engage students in an active learning situation that used 3D Printing as the delivery method. Active learning is a central idea in constructivist learning; it is used to frame many instructional delivery methods that are employed in education; the flipped classroom, kinesthetic learning, problem-solving and student-led instruction (Lai, Luong, & Young, 2015; Le Doux & Waller, 2016; Trust, Maloy, & Edwards, 2018). The constructivist instructional research supports the notion that students learn deeply when their learning is active and connected to something that has been learned prior to instruction or is familiar (Eshach, 2007). The positioning of the lab, the support for the facility, and the design of projects and activities were all focused on producing significant activity on the part of the learners.

Participants were asked to sign a consent form and participate in the study before interviews took place. The consent form described the interview obligation as well as the documentation in the form of photographs and event sign-in sheets that students needed to provide for the study. The consent form also described the purpose of the study as well as the steps that were taken to protect participant identities.

Each participant was assigned a pseudonym that identified them in the transcripts to protect their identity. The recorded conversations were stored on a password-protected cellular phone that provided limited access to unintended users. The transcripts of the interviews were stored on a password-protected laptop, which also provided access only to the researcher with limited access to unintended users. The identities of the original interviewees and the pseudonyms that they were assigned were recorded on a list that was stored on the password-

protected laptop. The transcripts of the conversations were populated with the participants' code names, and the researcher used member checking to confirm the content of the student interview sessions. The participants' code names are derived from the popular American Naval aviation film "Top Gun" and "Top Gun 2".

### **Data Analysis**

The content of the interviews was transcribed via transcription software Dedoose. The transcripts of the conversations were scanned for manifest or directly observable phenomenon (Hays, 2012). The phenomenon was descriptive coded according to phrases in the first wave of data analysis (Hays, 2012). The first wave of data was secondarily coded in a thematic analysis to establish a pattern of observable behaviors and experiences (Saldaña, 2013). The researcher took notes after each interview, and each 3D PARC sponsored event and a reflexive journal was kept on a weekly interval during the period of the study. The contents of the notes specified the number of event attendees, the amount of student participation, and the theme of the event such as outreach, peer education, or competition. The reflexive journal recorded any occurrences that are germane to the possible selves of the participants or the researcher.

The participant responses were coded in three different ways. First, they were emic coded according to the participant's identification of their expected/current self, future self, past self, and feared self-identifications (Hays, 2012). Expected self-emic phrases may start with "This semester I will...", "After I graduate I will...", "When I was younger, I was...", and "I don't want to be..." respectively. The second form of coding was thematic; the statements of the participants were analyzed for themes and patterns of possible selves (Hays, 2012).

The emic coding and the overarching patterns provided support for evidence of the participants creating meaning about the 3D Printing process. The generated meaning was viewed

from a constructivist paradigm for qualitative research and instructional design. In these paradigms, the researcher works to address social injustices and allow the learner to gain meaning through provided experience (Christensen, 2008). Specifically, constructivism holds that knowledge is constructed when a learner adds their current novel learning experience to their existing body of knowledge (Eshach, 2007). The present, past, future, and feared narratives, along with their associated patterns provided insight into how 3D Printing was assimilated and what bodies of knowledge it was most effective for.

The emic coding and the potential patterns that they present were also useful because of the potentially unique nature of human and technology interaction. The patterns of possible selves provided information about how end users are affected by their interaction with digital fabrication technology (Aagaard, 2017). The possible selves that were presented may be understood from the perspective of the fabrication machines, actually changing the participants thinking in an observable way.

### **Credibility**

The data collected and the subsequent primary and secondary coding was reinforced to support credibility in the study (Hays, 2012). Three measures were taken to support optimal trustworthiness in this study. First, the previously mentioned reflexive journal gave insight into the thought processes of the researcher at the time of the interviews and events. Second, the documentation of the events and 3D printed objects were provided as a part of the data analysis to support the assertions of the interviewee's statements. Additionally, member checks were used to confirm the content of the student interview sessions; a transcript of the conversations will be submitted to each participant for their review. Differences in understanding and content were resolved with the interviewee's impression as the guiding factor. Finally, the study was

conducted at the end of a prolonged engagement, the researcher, the students, and the institution have been 3D Printing for over four years (Hays, 2012). The confluence of a reflexive journal, event documentation, member checks, and a prolonged engagement provided a redundant system for data trustworthiness. (Hays, 2012)

### **Limitations**

The proposed study was a qualitative study and is therefore not generalizable. The study was designed as a qualitative description of the phenomenon associated with the adoption of 3D Printing technology. The study was limited in scope by the current college curriculum; there were not many established curricular studies that required 3D Printing. Only the students that knew about the 3D Printing activities or became engaged through the 3D Printing recruiting efforts on campus were able to participate in the study. The participants were the individuals that had time to dedicate to 3D Printing pursuits. 3D Printing pursuits can be time-consuming, requiring both intention and commitment to engage. This study was further limited in scope because it took place at a singular community college campus. The conditions presented at the campus are not universal, and the resources that influence these students are not the same across institutions. Finally, the study was limited because of the rate of exposure to 3D Printing. The technology is expanding at a rapid rate. Therefore, the opportunity to observe students who had never used or worked with a 3D printer will become increasingly more limited as the technology proliferates.

The data that was gathered from the study participants was limited according to the verbal abilities of each individual. Participants that were interested in and able to express themselves verbally did so. Participants that were not as available to express themselves verbally or through written language did not contribute as much data. The methods used to gather the data

were open-ended items that only lent themselves to individuals that are less self-conscious and more forthcoming with their mental and emotional processes.

### **Role of the Researcher**

The researcher had extensive experience with 3D Printing and the compulsion to provide an optimal, superior experience to community college students. The researcher of this study was biased due to his obsession with 3D Printing technology and dedication to the community college. The researcher was extensively involved in supporting the 3D Printing Club activities and the students that are participating in the study. For example, seven of the nine 3D printers that are being used in the lab were the researcher's personal machines. The researcher was inclined to think that 3D Printing was a useful delivery mechanism for informal learning. The relationship between the researcher and the participants has been reasonably close. The former was the faculty advisor to the club of the latter. The researcher was the source of almost all of the knowledge that was being exercised in support of the 3D Printing Club. He was the person that was developing the programming. He had assembled or donated all of the 3D printers in the lab, and he was also an ardent supporter of the community college mission and the students that it served.

The biases of the researcher, which leaned towards positive regard and an appreciation of possible levels of knowledge may have potentially skewed the interactions with the research participants. It is possible that the intensity of the researcher's presence may have been a factor in the study. The socio-economic status of most of the participants was different from that of the researcher; however, this was not likely to be a factor in the interactions. Furthermore, the participants of the study were mostly students under 25 years old; the age differential could have been a potential factor to monitor.



## **Conclusion**

The purpose of this study was to provide information about the reported possible selves of community college students when they engage in 3D Printing activities in an informal setting. The participants were observed while they were in the 3D Printing lab, as well as interviewed and surveyed following student group activities, 3D Printing design, and fabrication sessions, or public events. The students who engaged in 3D Printing have contributed qualitative data in the form of responses to individual interviews and document analysis. The two modes of data collection, the use of summary notes, the analysis of documents, and member checks were designed to give a complete picture of the experience and reported possible selves of the students.

## **Chapter Summary**

This study was an examination of what community college students report about their possible selves after engaging in the practice of informal 3D Printing. The study took place at a large community college in the Southeast United States, the Community College of Booker T. Washington County (CCBTWC) which housed a 3D Printing lab that featured 32 hours of open lab time, 3D Printing club meetings, field activities, and guest speakers. The student participants in this qualitative case study contributed information to the understanding of the phenomenon by participating in interviews and providing documentation. The resulting data was able to offer some initial impressions about the dynamic that is created when community college students engage in hands-on STEM-based activities.

## CHAPTER 4

### DATA ANALYSIS

The purpose of this case study was to describe the possible self dynamics of community college students who engage in 3D Printing. Participants in this study 3D Printed in a variety of settings. They shared their experiences and provided reflections about how their past, expected, and future selves were influenced by the practice of digital fabrication.

Every skill that can be practiced or improved upon across human history is not valued by more than a small group of people until it has been honed to an elite level. 3D Printing is a skill that breaks the pattern of valuing elite experience. The results of this study demonstrate that beginners in 3D Printing have an unprecedented impact that overshadows the ability to make plastic objects with a computer. The skill of 3D Printing and the objects created are not the most transcendent aspect of the data collected in this study. What is most transcendent is the knowledge created by the case study participants, and it's almost universal effect on the possible self. 3D Printing allowed for the participants of this study to learn something new about themselves that was valuable, impressive, and complete without needing to hone their skill to an elite level.

Every person that contributed data to this study, except for Slider has less than two years of 3D Printing experience. The students in this study were heaped with admiration from their peers, their pupils, and their families. The practitioners had a significant audience. The minimum audience that each 3D Printing practitioner reached as a result of instruction, peer collaboration, public forum, or technical conference was between 12 and 1500.

Almost half of the case study participants were monetarily compensated for teaching others how to 3D Print or design 3D objects. 11 of the 13 participants saw 3D Printing as a legitimate and necessary part of their personal and academic development. One participant was

sought out by world-class mountain bikers for their skill and ability to design and fabricate digital objects.

Thirteen community college students engaged in twenty-six interviews for this case study; the meetings were transcribed using Temi transcription software. The transcribed conversations were member checked for content and coded using DeDoose data analysis software. The interviews were then analyzed for manifest and directly observable phenomenon. The reported phenomenon were secondarily coded for thematic analysis.

Table 1. provides the participant descriptions. First, Table 1. provides the participant pseudonym. Next are the demographics identifiers of age, gender, and ethnicity. The students intended major in community college is listed next. The student's intended major is followed by the modality of student participation. The participation modalities are the 3D Printing club (3D PARC) membership, leadership in the 3D PARC organization, use of the 3D Printing lab for course credit, and 3D Printing lab employment status.

Table 2. provides descriptions of the events and activities of each participant. The participant pseudonym, the most notable object that the student fabricated is listed. Next is the series of events that the students contributed to. Students were able to be presenters at a major community fundraising event for a local Charity, the Youth For Tomorrow (YFT). They had the opportunity to attend two days of presentations and demonstrations of digital fabrication at the East Coast RepRap Festival in Bel Aire, Maryland. They were featured presenters at the Prince William County Youth and Technology Festival. Finally, the status of participant ownership of a 3D Printer is listed.

Table 3. provides insight into the personal experience of each participant. The pseudonym is provided. The most notable fabricated object description is followed by the major

theme that was presented across the interviews. Figure 1. is a visual representation of the possible self dynamics presented in this study. A student enters the 3D Printing lab feeling figuratively small. The student deploys the tools of peer support, open access, and assessment free instruction on the way to completing their first 3D Printed project. The immediate result is that the student has a more enhanced expected self that includes the ability to 3D Print. The enhanced possible self is then able to take on more the more challenging tasks of 3D Printing instruction, completion of advanced projects, and community outreach.

Figure 2. is the cache of .stl files that students used to produce some of their digital fabrications. The .stl files images are accompanied by the participant pseudonym and a brief synopsis of the events that surround the .stl completion.

The data presented in this section is organized into two categories. The categories are objects attempted and student possible self factors. The objects attempted are presented through digital representations of .stl files that students attempted to print. The attempted object images will be framed with supporting information. The supporting information will take the form of stereo lithographs (.stl) files and documented information from the data collection sources. The data collection sources are the student interviews and, when possible, journal entries that cite the events that surround the production of the .stl.

Possible self factors are presented through evidence of student identity, outside actors, and the environment. Student identity is the construct that encompasses the greatest amount of data related to the possible self dynamics of the student participants. Outside actors are people whose actions influence essential elements of the student participant's possible self. Finally, the environment is a series of settings that are crucial to the possible self dynamics of student participants. The outside actors and environment comprise the majority of data describing the

student navigation of the educational infrastructures and pedagogy to secure resources necessary to support their possible self identity.

The three possible self factors: student identity, outside actors, and environment interact dynamically. For example, a student will find themselves in a place and time where their future possible self is consistent with STEM practitioner (student identity). The student will be in a setting or group of people that will influence that possible self (environment). Within that environment, there may or may not be an individual or series of individuals who contribute to the student's possible self identification as STEM practitioner (outside actor).

### **Trends in Collected Data**

#### **Student Identity**

The students in the study revealed their significant academic and developmental student identities through statements that were related to their self-awareness. Self-awareness statements were a leading indicator of student expected and future possible self identity. The level of understanding of how their actions affect their present and their future was a theme across interviews. 23 of the 26 recorded conversations had a self-awareness coded passage. Six of the 24 conversations had more than ten passages with the code occurring. The students demonstrated their knowledge through self-warnings and affirmations that were present in both their past and their future.

Self-warnings are topics that students discuss as a reminder of potential obstacles. The subjects of the warnings were about things that the students were conditioning themselves against. Goose talked about the developmental dynamics of going to college in the same geographic area of his home, “first you get used to how college works and then after you get used to your personal life and then doing everything at once. It could be very overwhelming.”

The warnings came up as pre-emptive alerts to danger or difficulty. Viper shared lessons from his experience as a VEX robotics competitor: “I've built several robots over the years, and if there's one thing I've learned, it is a nightmare to try and do things on your own.”

Viper’s experience with fabrication and construction nightmares had a series of attempted objects to confirm his preference for collaborative robot construction. For his first-ever 3D Printing project, Viper printed most of the parts of a 3D Printed a robotic arm. The project remained incomplete at the conclusion of the study. The robotic arm that Viper selected has over 30 3D Printed parts plus electronics, stepper motors, and servos that control the movement. Samples of the digital files are provided in figures 2.1, 2.2, and 2.3.

Chipper illustrates the process of developing knowledge through experience in his first interview. In this section, Chipper is summarizing several years of leaving and returning to community college.

*Researcher:* The first couple of times that you came through college was it one of those things where you're like, I'm still more with my friends a... I'm just doing this college thing?

*Chipper:* Yeah, it still more doing with my friends and doing the college thing. I was just still having fun, you know, being youthful. I was trying to get past that, and I didn't know how to say no at that time. I was trying to get better at it, like cut back on all the games, like the little kid games. You had to mature, which is the hard part when people still want to be able to try to be in your life.

Student demonstrations of self-awareness revealed affirmations of significant past experiences. An example came from Maverick’s recollection of his journey through computer science “In terms of computer science; I did relatively well. I did have my times where I was like, Oh my God, what the hell is this? But, as I (advanced) in Math I was able to do more than I thought I could.” Maverick’s demonstrated identity in this statement is important. It documents that community college students are aware of the new skills that are made available through the process of learning.

In the following passages, Phoenix shares advice that she got from others versus the decisions that she made for herself. The difference between the two reveals an identity that is indicative of a confident student.

*Researcher:* how's college going for you so far?

*Phoenix:* It's actually going pretty well. Better than I expected it. It's not like everyone in high school made it sound like the end of the world and stuff like you are just going to be stressed out 24, seven, and it's just work, work, work. But if you just manage everything, like it's not that bad cause I still have like A's and B's in all my classes and so it's really nice.

*Researcher:* When people were telling you all these things about how college was going to be crazy and everything, did you ever think that maybe you shouldn't or you're going to do anyhow, but you were nervous about it?

*Phoenix:* Yeah, I was just really scared about it and stuff because it's a whole new thing and it's way different from high school, and I've heard of people dropping out and stuff like that, and I was just like scared that that could happen to me and stuff.

“if you just manage everything, like it's not that bad cause I still have like A's and B's in all my classes.” Phoenix’s expressed student identity has the skills and knowledge to manage college-level work.

When demonstrated student identity takes the form of warnings or affirmations, they are examples of lessons learned and skills acquired. The demonstrated student identity indicates that the participants have an excellent idea of what actions need to be taken, avoided, or navigated to be successful in higher education. They are also indicative of the exercise of personal power.

### **Past Self Knowledge Construction Process**

**Past Self.** Specific parts of the interview protocol focused on creating a picture of the study participant’s past self. Specifically, what their mindset was and what they had anticipated for themselves at the time. The contrast between the past and the expected self produces strong reactions in the case study subjects.

*Researcher:* So now if you could look back on yourself five years ago and see yourself 3D Printing and using this technology today, how do you think that you would react?

*Phoenix:* I would probably be pretty hyped about it because at the time I was getting into like sculpting and stuff. I just really enjoyed doing that and making 3D figure and everything I would be really excited seeing myself doing something.”

3D Printing is another potential form of self-expression for Phoenix. 3D Printing is an added capability for Phoenix’s expected self; she is “really excited” to be augmenting her expected self identity with 3D Printing skills.

Hollywood shared his feelings about his ability to use a 3D Printer for a class project in his engineering A.S. coursework.

*Researcher:* So, if 16-year-old Hollywood were to see you using a 3D printer today, what would 16-year-old Hollywood say? How would he react?

*Hollywood:* (*Pats self on the back*) I'd be really, really proud. Yeah. Uh, he'd be like, wow, you learned a lot, huh? I'd be like, yup, I know how to move a file over to here. That's it a couple steps, hope nothing goes wrong, but then we can get it all set up and printed. He's gonna be like, yeah, you're really dedicated to this, huh? Good job. You matured more to like you're not fooling around as much. Yeah. You're getting your work done. You're actually doing homework. So, you stay staying after class too. Wow. You've never done that before? Unless it was for football. Yeah. Oh, so he'd be proud.

Hollywood’s experience in 3D Printing has produced a sensation of pride. He is proud to have a command of a learned process. Hollywood’s new skill fits well into his new discipline and academic routines. 3D Printing has augmented Hollywood’s expected self identity. Past self Hollywood had no 3D Printing experience but expected self Hollywood does. The expressed personal identity sentiments of Hollywood’s past self include high self-esteem, pride, and satisfaction that are initiated while using a 3D printer.

One last example of reported a possible self dynamics difference comes from Sundown. Sundown talks about becoming aware of a new personal set of capabilities that were made possible through 3D Printing. In this conversation, the “heart” is a .stl provided in figure 2.4. The



.stl is complex, and it was attempted twice before it's successful completion. The difference-maker for the completed iterations was that Sundown needed to specify the 3D Printer profile for his object. He was using general settings for his first two attempts, but he needed to be specific. The complicated design and surprise object inside the heart made an impression on Sundown and his family, as indicated by the conversation.

Researcher: So, 13-year old Sundown is looking at you now using a 3D printer. What would, how would 13-year-old Sundown react to you're using these machines?

Sundown: First of all I, I didn't even know these things existed at that time. I'd be so surprised by how like a filament roll is like 20 bucks and um, the fact that I could like print a heart for him, I'm going to be like, how'd you do this? I think I nev... cause I think CAD ended designing (for me and) my goal along the lines of comp sci. Or a little bit near it I think. I think I'd be really surprised that I was able to get even closer to comp sci (now) even though I don't want, I didn't want to be at (comp sci back then), um, it'd be in amazement.

Sundown's expected self is prideful as he shares his experience with his past self. Inferred in the conversation is that the expected self is stronger than the past self "I think I'd be really surprised that I was able to get even closer to computer science (now) even though I don't want, I didn't want to be at (computer science back then). The middle school coursework that past self Sundown endured created a past self student identity that would not pursue STEM coursework. Sundown's conversation indicates that the 3D Printing experience has shaped his understanding of his expected self from a STEM avoidant middle schooler to an aspiring engineer. Since his past self was certain of his aversion to STEM-based pursuits, 3D Printing has misshapen that certainty to create a different expected self for Sundown. Expected self Sundown is a more worldly, more technologically aware college engineering major that is excited about the prospect of working in the industry.

### **Misshapen Self to Future STEM practitioner**

In the data collected from Goose’s conversation, there are more examples that illustrate the concept that the 3D Printing experience has the potential to shape, misshape or amend possible self identity in community college students. Goose, a first-year community college student, played soccer every weekend through primary school. He knew that he did not have the “talent” to reach an elite level of soccer competition as a young teenager. He also did not have a future self that had formed around an academic focus. This quote indicates that 3D Printing has helped Goose solidify a future self in STEM.

“I think he (my past self) would be first very confused of how I, first of how I went from playing soccer to working with machines. So I think he would be very confused, but I think he would also be excited because you're like, wow, you know, you're actually doing something important, something, something that's gonna help you get a good career.”

Goose’s process of working with machines has shaped a new identity of a STEM practitioner that is doing work that is germane to a “good career” for his future self.

The reported differences between the past, expected, and future selves in these conversations provide a valuable revelation about student growth and development. Goose’s identity development is taking place at an institution that categorically graduates low numbers of engineering and computer science majors (National Center for Education & Institute of Education, 2019). Conversations that take place between the student’s past self and expected self illustrate the crucial fact that community college students can shape their future self identity through the practice of 3D Printing.

### **Technological Exploration Shaping Student Identity**

The 3D printers and the 3D Printing practice in this study provided a substantial value as a cost-free, easily accessible platform for peer-led project-based exploration and learning.

Collected data indicate that 3D Printers provided a platform for the active shaping of student identity. For many of the participants, 3D Printing contributed more detail and structure to an already existing future self identity of Engineer. Participants took what they knew about engineering and used the machines in the lab to explore skills that they thought would be useful.

Iceman is a transfer student from a selective research university. He has four years of combined study in Engineering at his previous institution and at CCBTWC. The CCBTWC 3D Printing experience augments four years of credit study in Engineering that Iceman already has. 3D Printing is the opportunity for him to develop the AutoCAD design skill that he sees as urgent.

*Researcher:* What do you think 3D Printing has done for you?

*Iceman:* It's exposed me a lot more to AutoCAD, which is something I'm going to be doing without a doubt.

Iceman is not alone in taking control of his personal process of skill acquisition. Stinger uses the experience to gather STEM-based skills that he considers to be critical earlier than the CCBTWC engineering curriculum requires. He can see his STEM-based future, and he knows that he lacks some vital skills that 3D Printing experience will help him develop.

*Stinger:* Yeah. Goose showed me a bit of the basics on how to edit objects and stuff like that...

*Researcher:* It sounds like what you're doing is some self-directed study. Is there a particular reason why you're doing that self-directed study versus waiting for classes?

*Stinger:* Just to get ahead. My main objective is to get the most out of college and, you know, using the resources here now instead of waiting to use them, I think that'll propel me forward faster and being able to sort of advance my skills early on instead of having them wait a few months and it just, it just makes more sense.

*Researcher:* I see...is that something that, that you kind of came across that logic through some other prior experience or is that something that was unique to college for you?

*Stinger:* Yeah, I'd say that was unique to college. My mentality was just that, you know, I'm not gonna spend the rest of my life in college, so I had to make the most out of it, especially when money's involved.

*Researcher:* Good point. Okay. Raises the stakes a bit. Yeah. All right. Well then, so, um, how's the way, if everything turned out well for you and your trade, your dreams, what do you think, what do you hope is going to happen in terms of your career?

*Stinger:* I hope that I could get a really, I hope I could get an important job, uh, has to do with manufacturing. Okay. Yeah. I would like to work at Tesla or some other major car company.

Stinger is increasing the amount of detail that he is attributing to his future self identity. His 3D Printing experience is shaping and refining his possible self as an engineer through STEM-based exploration.

Goose is also an engineering major. Goose teaches robotics and 3D Printing at a local middle school for a non-profit organization. Goose's conversation illustrates a student who is using the lab to sculpt his future self. Goose is most eager to develop his skills in machine technology.

*Researcher:* When you look at yourself this academic year, are you on the same trajectory as you were when this year started? Are you still going in the same direction?

*Goose:* I still want to continue with engineering. That's my current plan. However, I do feel that I've learned with 3D Printing I think I've learned more. It's helped me learn more and I think it's gonna help me out with my degree. It's helped me learn more about technology for the most part. And that's something I feel like I always lacked. So with 3D Printing, the club has helped me learn more about technology, which I think will help me in the future. And I think it's going to; it's just made me realize that I do want to continue with engineering. I want to continue with working with machines.

Goose describes how working with the 3D Printers has given him an experience that is helping him solidify his future self identity as an engineer.

*Researcher:* So. What kind of, what kind of engineering would that be, do you think?

*Goose:* Yeah, that's a good question. So now I'm going into mechanical engineering mostly because I, I've enjoyed working with machines so far for like with the robots and as robotic. I enjoy that. The 3D printers really interests me. Yeah. Yeah. So the 3D printers are sending another reason that I think mechanical engineering may be okay. I just, I've enjoyed working with machines.

*Researcher:* Cool. Very cool. All right. Working with machines in not in general, well in general, working with machines, is this really a big thing for you?

*Goose:* And then maybe get more specific as I go through college on get more specific.

This next passage speaks directly to the process of knowledge construction and the efficacy of hands-on STEM-based pursuits.

*Researcher:* It's not as though you always seen yourself as someone who would be doing robotics or someone who would be doing 3D Printing or you were, you're a curious person, and that curiosity led you to what you're doing now.

*Goose:* Yeah, that's definitely what it was. Cause I never felt, I had this drive for a specific career. I always felt kind of lost with that. Honestly, that kind of worried me. When I first started high school, I was like, Oh, you should know what you're doing. And I just thought, I don't really know what I'm going to do and that does worry me because time's running out. So I said, well, I'm just going to start trying different things, trying to find something because to me I gotta I feel the best things for me are just going out and taking the action. You can't; I don't think waiting around for something to come to you is the best option. It's best to just take action and discover some fun things, be open-minded.

Goose resolved to “take action and be open-minded.” His open mind is constructing an understanding of mechanical processes. Goose’s curiosity has led him to opportunities that he did not expect; he was able to earn a job as a robotics and 3D Printing instructor at a local middle school. Goose is using the job to get the curriculum across to students whom he seems to have something in common with. What is crucial about his passage is the insinuation that he is granting valuable knowledge to the children that he is working with. He can see them benefiting from it in their future.

*Goose:* I'm honestly, I'm really, I'm really, I'm honored to have this job just in general. I think it would be very, I think it will definitely help out the kids with STEM. I think it's definitely going to increase their knowledge, which will increase their opportunities. They'll be able to; they'll just know they'll have a base to start on; they will have a knowledge base to start on for example.

*Researcher:* Good point. Yeah.

*Goose:* And from then from there on, you can start building your base. You know, they can learn more about 3D Printing. They could start learning more, and then there'll be able to meet people who are in the field. They'll be able to get good connections and get better opportunities for whatever they're seeking in life.

*Researcher:* And so now, how do you feel about being the person who's delivering that?

*Goose:* So it makes me feel, it makes me feel very, almost important because because I'm the one who's like in charge of giving the most information and it makes me really happy when they're very excited to learn about it. You know, they'll see the machines working and like, Oh wow, that's amazing. They want to learn more. Show them where they can make, right, and explain to them how the pieces work out. Yeah, I definitely do feel that the whole, the whole program is just very useful for the kids in general.

The results that are communicated by students who already have an identity as an engineer or STEM practitioner are surprising. The case study data presents evidence to suggest that as the students construct an understanding of STEM pursuits, they are also shaping an understanding of themselves and their futures as STEM practitioners.

The students without a strong STEM identity shared interesting insights around 3D Printing as well. The future self they reported before 3D Printing was misshapen into a different future self after 3D Printing. The changes in their future selves are directly attributable to the experiences they had around 3D Printing. 3D Printing has misshapen already established future selves to include STEM pursuits. When this interview was conducted, Phoenix was going through her initial training as a 3D Printing technician. In her initial training, Phoenix selected a small, 3-dimensional version of a "Pac Man ghost," which is presented in figure 2.5. The file did not complete on the first try.

*Researcher:* Now, I'd like to hear what your thoughts are now that you've been 3D printing.

*Phoenix:* Well, I, I enjoyed it. What I did learn was pretty simple and I'm excited to learn more about it and stuff, especially to get out there and help the kids because when you help other people, it helps you get like, remember, contain all the information from learning, and so I'm pretty excited.

Phoenix's job will require that she split time between the college campus and a local elementary school. In this section of the conversation, Phoenix's work history and the events that led to her deciding on her intended major are discussed.

Phoenix: I'm in between right now, half of me, I want to become like, a child therapist and open my own practice one day. But then half of me wants to go into social work cause I just, I want to help kids with like less fortunate like backgrounds and stuff like that. I've been through tough times cause (I know) they really need that support system in order to grow up well. So I just, I just want to be there to help.

Researcher: So, you volunteered at a preschool, so does that preschool experience, kind of inform the child psychology versus social work thing for you?

Phoenix: yeah.

Researcher: And if things didn't go so well, and you didn't become a social worker or a child psychologist, what do you think that you would do?

Phoenix: I don't really know cause I never really like considered that, but I know like it could happen, I guess I would just try my best and find something to like settle with. I don't really know.

Researcher: So how likely do you think that it is that you're going to be a psychologist, child psychologist, or a social worker?

New Speaker: Like probably 80, 90%.

Phoenix's past self provides the roots for her decision to be a social worker. A psychologist/social worker is a job that Phoenix is seeking, 3D Printing is a job that is seeking Phoenix. The experience is powerful enough to stimulate a different future self for Phoenix. Phoenix is considering some new job possibilities after less than ten days of 3D Printing experience.

*Researcher:* And so have you, do you ever see yourself using technology as a, as a career?

*Phoenix:* Yeah, I would. I mean especially with this 3D Printing job now because I mean I was like pretty happy when you called because I was like really interested in it, but I didn't know how to get into it. But seeing like this and it could lead to other opportunities and I would be fine getting in like a field where tech leads to that.

*Researcher:* And so, and you feel pretty good about that particular, 3D Printing that, that possibility of using technology?

*Phoenix:* Yes.

Phoenix's interest in 3D Printing is connected to her already established expected self identity of artist. After 3D Printing, her future self is augmented with the possibility of working in a field that involves technology. The data that Phoenix has contributed presents evidence to suggest that

the newly constructed knowledge around 3D Printing has created a new future self for Phoenix to consider.

### **Expected Self Resolution Increased through 3D Printing**

Wolfman is a first-year, first-semester student at CCBTWC. He intends to complete the engineering curriculum and transfer to a four-year university engineering program. Wolfman's reported childhood experiences give the impression that his past self was strongly identifying as an engineer. "I used to be super into remote control cars, and so I'd take them apart and replace parts, modify it. And that really fit into kind of what engineering is." The is passage indicates a broad spectrum of possibilities in engineering, the specifics of Wolfman's identity, the sharpness or clarity of the future self of engineer is not fully recognizable.

Wolfman sees himself as outside of popular social circles. He describes himself as a nerd, which allows him to be a part of a group of "other people" who have varied and broad interests.

*Researcher:* How else would you say that you would describe yourself in high school?

*Wolfman:* Nerdy, nerdy, nerdy.

*Researcher:* What does that mean?

*Wolfman:* Basically, anything that other people wouldn't have that big of an interest in, I was probably into it. I would watch TV shows that people didn't really watch, and I'd get into those, but for the most part, it was mountain biking.

Wolfman placed a zealous, intense focus on mountain biking, which resulted in intense training and discipline to get better at the sport.

*Researcher:* So, you got into mountain biking. Were there any other kinds of things that you liked to do outside of high school?

*Wolfman:* Honestly, mountain biking was really it. I would get out of school; I'd come home and immediately get on the bike and ride around until it was time for dinner...there's an elementary school that has like a huge, almost vertical Hill right next to it. I would bring out my friends, and I ride straight down that Hill down the stairs that go down the Hill. Then I tried to peddle back up.



*Researcher:* Wow. How many times did you have to try before you would actually get up and down that Hill?

*Wolfman:* A couple of weeks of just constantly going. It was mostly to build up the strength and the endurance, but that led into me getting into racing later on.

Wolfman's expected self is a nerdy, mountain biking, non-traditional learner. This point in Wolfman's life experience suggests an expected self that is not exceptionally clear about the details of his future self as engineer.

Wolfman's mountain biking led him to a national park where the mountain biking trails are world-class. While riding the trails, he was able to meet with and talk with an international mountain biking champion. "Afterwards, I talked to him, talked about like the engineering stuff that I was into at the time, and he suggested that I try racing just to really get to know the sport because what they need is engineers that know how to ride." Wolfman continued with his interests in engineering, now encouraged by the advice of an international champion: "I would definitely say I, I firmly decided that I want to do engineering."

Wolfman was able to take several classes that emphasized 3D design and engineering concepts in high school. He was able to gain some useful skills in 3D design through his high school coursework.

(Tinkering as child) was a good segue into the design process, and it was my last year of high school where I took a bunch of electives that were engineering based... I learned how to use CAD programs pretty quickly. And so that's what I've been doing ever since.

Wolfman's experience in the CAD course was confusing. CAD is a skill that he knows is central to engineering, but his classroom experience has a slightly chilling effect on his engineering future self. The students that he paired with in his classes were well versed in CAD design before they started the class.

They already knew how to use like Autodesk inventor, how to program. They knew this stuff. And it makes me really question the American education system.

Like why can't I know these things right now? Isn't the school the place you come to learn these things? I guess they chose the right classes before I did. But you know, like as a freshman though, they don't, they don't teach Autodesk inventor, to people in junior high. They had somebody in their life that was showing them that stuff.

The confusion about when and where to learn engineering skills was significant for Wolfman. It is possible that the class undermined his confidence in his expected self skill level. He seems to be less aware of the engineering tools that he has at his disposal. Wolfman's high school engineering course taught him how to program a robot; this represented his experience with computer science. His explanation discounts his robotic and programming abilities. As he discussed the programming course, his strong grasp of the fundamentals of computer coding are woven into his renouncement of understanding.

*Researcher:* How about computer science? We've talked about how you're not really all that big in the programming. How'd you figure that part out?

*Wolfman:* It was my high school engineering class. We had to do a vex robotics thing where you program go forward this much go left, right? Yeah. But the way that I don't know, the way that the programming is formatted just seemed a little bit confusing to me. You basically had to open it up and then tell it that you're going to give a command, say what the command is, how long to do it, and then say that's the end of the command started over again. Open-loop. Step. Closed-loop. Yeah. Oh yeah. It just didn't make sense to me. It's a rule, but then nobody could really explain why you have those loops the way they are.

Wolfman has design, programming, mechanical, and mountain biking experience but no strong working identity as an engineer.

Wolfman has no other professional intentions as he starts his first year of community college. He wants to be an engineer, but like many first-time first-year students in higher education, he is dedicated to an academic field but has no specifics or clarity about his future endeavors.

*Researcher:* And what if things didn't work out and your dream career didn't work out? What do you think that you would do?

*Wolfman:* Just anywhere where I can be an engineering, I guess. Cause I don't know actually what I would do, and I think that's something to really consider what I do if I can't do engineering

Meanwhile, it is possible to see the “high definition” resolution that Wolfman has on mountain biking. At this point in the conversation, Wolfman is very intent on mountain biking and very determined, but not yet focused on engineering execution. This is an understandable discrepancy because he has yet to take his first engineering class.

*Wolfman:* It kind of plays back into mountain biking as everything does in my life. Bike frames that have suspension in the back of the bike. They've all got a unique linkage, some kind of thing to actuate the shock because of patents and because of who has the copyrights to this type of design. That's why there's a lot of weird suspension and that's why these companies when they have their patent, they stick to that. They don't deviate away from what they've been doing, even if it turns out not to be the best way to do it most of the time. And that's kind of where the downfall happens. These designs are good enough that they're very effective. It's difficult to find something new. But I was really interested in why people would stand by one bike and one type of suspension platform and hate on another one. And there was a YouTube channel that basically used to software that would show how it works and the leverage ratio how efficiently it would peddle and how it would handle breaking. So because my frame, when you're on the brakes on the rear, the suspension gets really stiff. So the wheel will give you the friction you're looking for sort of, but it also makes you lose traction in something very steep and very rocky.

*Researcher:* So skidding.

*Wolfman:* So, yeah, when I'm racing, if I'm trying to slow down and I don't want to eject myself over the front, I need to use the rear brake. But if I'm using the rear brake, I lose a lot of traction, and the wheel slides out somewhere, and I don't need that.

*Researcher:* No.

*Wolfman:* I have to either slow down like crazy before I drop in or just don't use the brakes and hold on.

*Researcher:* What about feathering the brakes? Can you feather fast enough?

*Wolfman:* You can't feather fast enough when it's that bumpy, you don't have enough control over your finger. So that's why I'm trying to make the brake Mount. I'm hoping it'll work just a little bit better, and there's already a different one, an entire brand in the world cup that's doing that for one of their bikes. So. So that's why I think it'd be feasible.

Wolfman's conviction to ride mountain bikes also compels him to consume an extraordinary amount of information about mountain bike construction and design. The

consumption of that information led to a deep understanding of mountain bike suspension and control systems. Wolfman is able to use his understanding to design his own unique mechanical solutions. He used his design skill and collaborated with his peers to produce a new mountain biking component.

*Researcher:* So, you're telling me that you saw a way that another company was designing brakes to retain more control going downhill you made and designed your own copy and now you're printing that it in our lab. Is that what you're telling us?

*Wolfman:* Yes, And I have a lot of approval and support from the brands that have made a lot of the parts that I'm using. Like Common Cell. I showed this off to them and they thought it was really cool and they actually want me to send them pictures of the results, they'd be very interested in it.

*Researcher:* That's awesome.

In this conversation, the researcher and Wolfman are discussing the details of the Mountain Bike brake mount design.

*Wolfman:* The diameter of this is exactly what I needed to press in a bearing that I got. Okay. So I'm going to press in two bearings to hold the weight a little bit better and take up the space. Um, probably put like a piece of felt or something on that side so it doesn't grind up against the frame. Um, so the spacing between these two, I don't know what you'd call them.

*Researcher:* Supports.

*New Speaker:* Yeah. Uh, this is eight millimeters because that's what I thought the dimensions were according to the website where I bought rod ends. But, um, instead, it's 12 millimeters that way with an eight-millimeter hole through it. But if I get a six millimeter, it should be eight, like a six-millimeter hole, it'll be an eight-millimeter wide thing. So basically, I can just do smaller hardware. Do with the cast aluminum. Cause currently right now the eight-millimeter, uh, rod ends there. It's overkill.

This section of the conversation was focused on getting the finer details worked out of his design. The parts being discussed were the first and second prototypes of his mountain bike solution. This conversation led to new design cues that were to be incorporated and manufactured in a short time frame. Wolfman used his Mountain bike connections to get an

aluminum version of his bracket produced using a lost-wax process, the mounted component system moves and flows well.

Wolfman's past, expected, and future possible selves all indicate that he is an engineer. By employing his exceptional knowledge and dedication to mountain biking, Wolfman managed to manufacture multiple prototypes to solve a very common problem that is present on very expensive, world-class mountain bikes. He has had his prototype cast in aluminum, mounted on his bike, and it worked.

Wolfman's story is an example of a student who has used 3D Printing to bring significant experience and provide exceptional clarity and focus to his future self identity. The important knowledge construction aspects of Wolfman's story are presented in his consumption of technical mountain biking information combined with his practical field experience. When these two elements blend with an already existing design skillset and open access to 3D Printers, we see a constructed engineer with a valuable set of applicable skills.

For Wolfman, his engineering identity is no longer presented with broad strokes. Instead, it is specific to an industry and activity, and 3D Printing has allowed him to make significant contributions to mountain biking. Wolfman has used technical information and digital manufacturing to solve a real-world problem in mountain biking. All Wolfman has to do now is complete the engineering curriculum at CCBTWC and transfer to make his future self as engineer "official."

### **Factor: Outside Actors**

The data around the student's possible selves suggest that there are ways in which students have the overarching themes of their future selves influenced by other individuals. These individuals may influence the student directly or indirectly. They may shape or misshape a

specific future self. For data to be presented in the section of possible self actors, there must be a specific mention of an individual, and that mention must be made as part of a conversation about the student's personal and academic development process. The following section presents collected case study data around outside actors.

### **Influential Teachers**

A notable pattern that emerged from the interview data was the overwhelming presence of influential teachers in the possible self development of the participants. Merlin shared a favorite teacher experience.

*Researcher:* What is it about Mr. Collins that you thought worked for you?

*Merlin:* The way he simplified stuff. So being a math teacher, he simplified a lot of things, you know, to understand, which was good for me.

Merlin used his understanding of math to design a custom .stl of an HVAC air distribution fan; his design is displayed in Figure 2.9. He loaded the customized file into an available 3D Printer and printed it. During his first attempt at digital manufacturing, Merlin had completed the custom design to production life cycle in less than an hour.

Other students described a favorite teacher who took additional time to make sure that the students understood the curricular material. This was particularly true of math teachers in high school and community college. A favorite teacher was mentioned 57 times across 26 conversations. A favorite math teacher was mentioned 12 times across 26 conversations. Stinger, like many of the participants, shared a story about a favorite math teacher.

Uh well, she sort of steered me in the direction that I was able to... She sort of gave me the help that I (needed) to be good at solving problems because beforehand, I sucked at Math, but she was very calm and concise in her approach with me.”

“So, whenever I had to ask her questions or anything like that, she said, she took her time and she took the time out of her day.

Many of the students began to shape a plausible identity of STEM practitioner or engineer by working closely with a math teacher in high school. Conceptually, mathematics is a subject that is particular and concise; it lends itself to rigid rules and singular, objectively correct answers. The outside actor data reported by students in this case study indicate that the study of the subject matter is different from the instruction. Many of the study participants gained confidence and skill in math through a more subjective and personal approach to instruction.

In his conversation about his high school experience, Goose shared his opinion on the importance of high school teachers. He compared two teachers from two different math courses.

*Goose:* I noticed that sometimes the teacher also affects how you like your subject so that year that had that teacher, I just when I go to the math class, I kind of didn't want to go, (laugh). Oh, I don't understand, and I'm going to have a quiz. I don't understand the quiz! The next year I had a better teacher. I had a great time in the class. I was really excited to go into class. I wanted to see what the teacher had to say."

"Researcher: Was this your senior year class?"

"Goose: That was my senior year math yup."

Goose's possible self was able to change from opposing attending math class to enjoying it. This is consistent with outside actor influence on the possible self data across the study.

Sundown shares his story about his favorite teacher in high school, Mr. Cooper.

*Sundown:* So, my favorite teacher, his name is Mr. Cooper; he was my math teacher. He taught me Geometry and Calc AB. They were very good teachers, and those are my calc AB and geometry. One of my favorite classes

*Researcher:* And so you mentioned that somebody mentioned to you the idea of being an architect or civil engineer in your math class?

*Researcher:* Yeah, that was my teacher, Mr. Cooper.

Sundown's interaction with his math teacher goes farther than just having a favorite person to learn the subject from.

*Sundown:* I had AP calc AB. That was great for me. I had a great teacher for that.

*Researcher:* And what do you think, what do you hope that being a civil engineer means for your future? What's that all about for you?

*Sundown:* So overall, I think with my math classes, I thought when my teacher suggested architecture or civil engineering and I liked that class. I thought that would be not a job that I wouldn't like. I think I'd enjoy that job very much. Maybe it would turn into a career. And then, some engineering I also believe is a pretty good paying job. I just want to be able to to sustain my future family while also enjoying my career.

**Community College Faculty as Outside Actors.** It is imperative to consider the community college faculty as a strength of the community college educational delivery. The institutional focus on undergraduate instruction produces an educated student body that can navigate a multi-purpose higher education curriculum. The full-time faculty carry out two substantial roles: instructor and academic advisor. The effect of community college faculty as individual actors on student possible self identity is illustrated in this section.

In this passage, Hollywood is happy with the experience of proceeding through the community college Engineering coursework. Hollywood talks with the researcher as he reaches the ladder half of his second engineering class. Here, Hollywood is describing his preference for an engineering teacher, an adjunct instructor with a Ph.D. in Engineering. “Next semester I should be taking engineering 126 that's the computer language, machine programming, and C++. I have the same engineering teacher I'm taking this semester, Dr. Elway ‘cause I like the way he teaches.”

In this passage, Maverick is talking about how he has come to understand that community colleges and their faculty “care about their students.”

They have professors that really care about the students, and you know, not every school has that though. At CCBTWC we have like a huge amount of professors who care about their students I can even name some like professor Pear, Professor Calvo, and Professor Chrysler, these kinds of people really care about their students, and I've seen it with my own eyes. Like at the hackathon, Professor Chrysler will stay there until sometimes 12 one o'clock in the morning. So it's like you can see it, right? You can see the professor Calvo; he's willing to take money out of his own pocket. Then there's you who spent so much time helping the 3D Printing as well. And even, you know, you juggle so much, try to juggle literally



so much. You have so much on your plate, yet you always find time for this, the student community, our demographics and try to help through 3D Printing. Seriously. I don't know when you find time to sleep Mr. Nightingale.

Maverick's professional outlook and actions parallel the effort and dedication to the community that he sees in the faculty. Faculty who are visibly involved with the students have an amplifying effect. The faculty support the campus community, and the students support the community at large. For Maverick, the future self of STEM practitioner is an individual who is involved in society outside of professional obligations.

Cougar was able to find an adjunct Mathematics instructor that was available to tutor her regularly. In this passage, she is effusive about the fact that she is successful in Mathematics with the support of a CCBTWC teacher.

Then in college, my first semester I got really lucky because I got this professor that was amazing, and he still my tutor to this day. So, every class, every other class that I took at CCBTWC, he helps me, and he tutors me. So, I go to him like twice a week let's say. And then we work on homework, and we work on like corrections, and so I've gotten an A ever since I moved.

One of the most critical roles that community college faculty serve is the role of academic advisor. The faculty advisor for the Engineering program at Stinger's institution informed incoming first-year students about study abroad scholarship opportunities. In this quote, Stinger explains the thoughts that he had when he received an email about his study abroad scholarship at his college.

One of the people involved in the program named Rhonda Pryor. She's a professor at another campus. She sent out an email to everybody, all the students at CCBTWC saying that there was open, open slots for this scholarship to study abroad opportunity. And I just thought, well, it's to Jemison Tech, it's where I want to go, so I might as well take advantage of this.

Stinger applied for the study abroad program, and he was awarded a scholarship through a partnership between CCBTWC and Jemison Tech. Jemison Tech is a state-sponsored four-year

school with distinguished engineering programs. Stinger's ascension to this opportunity was a surprise to him; he heard about the scholarship during the first meeting of the 3D PARC.

Stinger: Oh my God!"

Researcher: What happened?

Stinger: I just found out I got a scholarship!

Researcher: Congratulations, way to go!

Stinger was awarded a scholarship before he finished his first semester of college, something that was made possible by the efforts and encouragement of a faculty advisor at his community college. The simple act of being selected for a scholarship helps to shape Stonger's possible self identity as an engineering practitioner. This reality was made possible because of the efforts of an influential faculty member.

### **Factor: Environment**

The environment that students interacted with before and during the study were the third significant aspect of the possible self dynamics of the study. The environment is crucial as both an influencer of and a setting for interactions to take place. The rules for hardware use, opportunities to collaborate, and the superior qualities of community colleges interlock to stimulate a dynamic understanding of the student self and facilitate knowledge construction. The following section illustrates the data that was provided about the environmental influences in the study.

**Employee Environment.** Phoenix's employment environment spans two different locations. Phoenix is a STEM tutor at a local elementary school and a 3D Printing tech at CCBTWC. Her placement at a local elementary school is framed by one of the community college institutional strengths, the lack of town/gown friction. The community college is miscible with the surrounding area. The students who attend the local elementary schools are the same students who attend the community college several years later. Phoenix is placed in an

elementary school and accepted immediately as a valued contributor. Through her employment placement, Phoenix's understanding of 3D design and printing is constantly upgraded to support the needs of the elementary school students that she works with. Phoenix's environment augmented her identity of artist. Now, she is an artist with technical skills, and she applies them successfully in a variety of settings

As a first-year, first semester student, Phoenix has been placed as a tutor at a local elementary school. Phoenix is valuable in the setting because of the lack of reliable resources for sustained learning around 3D Printing in the local schools.

In this conversation, Phoenix reflects the positive aspects of her job placements.

*Phoenix:* I thought about it, and I had them print their designs pretty small because I didn't want it like too big. Most of them were like three inches. So it was, it was nice.

*Researcher:* How did that; how did they feel about that?

*Phoenix:* They enjoyed it. They, yeah, they're just kids. They're just amazed by like the process of 3D Printing and taking their stuff and putting it to life.

Phoenix's conversation indicates an instance of an amplified job effect. An amplified job effect happens when a person's work within a setting has a positive impact on a substantial number of people. Phoenix's work allows her to "open new doors" for teachers and students who have struggled with the same lack of STEM identity compulsions that she had in the past.

*Researcher:* So working with children is a great way to support someone who's struggling like we talked about. I know you really wanted to be that to be part of your professional pursuits, helping young people who are struggling with stuff. How have you been able to help young people in your work study position? Have you been able to put your to be able to support someone in a way that you thought felt was important?

*Phoenix:* I mean, I feel like just being there and opening new doors and ideas for kids. With 3D Printing, it's good cause it gives them options for their future. Like future is just: "Oh I like this. Maybe I can continue with this one day." So I feel like that.

*Researcher:* So, expanding people's options to show them that there's a lot more they're capable of, maybe that's possible for them.

*Phoenix:* Uh huh yes.

*Researcher:* Oh okay. All right. Good. And do, and do you feel like that's somewhat true for you as well?

*Phoenix:* Uh huh yes.

*Researcher:* Okay.

*Phoenix:* Cause this like job, it opened like a lot of doors for me cause I mean I knew about 3D Printing, but it wasn't to this extent. Plus, because there are just so many career paths out there. It's kind of made me like stray from my non kind of like thinking to well maybe I should like go into this. And then Stuart told me about this uh, NASA program where they like take community college kids and like it's like an online course and then if you pass that you go to the actual like NASA and work with them. And so like I was considering doing that as well. So it's just opening like a lot of (opportunities)

Phoenix has seen her career opportunities expanded through a technical job in 3D Printing that she has held for less than six months. Her future self identity has a myriad of opportunities that are presented through the two job placements and the meaningful 3D Printing experiences provided by each. She knows for herself that her interactions with the school children around their 3D Printed objects have expanded their opportunities as well. The job environment is the platform from which STEM-based future selves are being developed for both Phoenix and her students.

**Higher Education Environment.** Many of the students in the study were unapologetic and pragmatic about their enrollment in community college. They explained how community college was the right institution for them for a number of reasons. The reasons that they cite are parallel with the strengths that educational experts associate with community college. The strengths of the community college are tools for the student's navigation of the formal educational structures.

The benefits that a community college education affords are front and center as students describe their experience. Specifically cited are the areas in which community colleges are superior to four-year institutions, lower cost of instruction, faculty focused on undergraduate education, direct engagement with the community, a diverse student body, and the convenience

of location. The advantages that community college affords were adopted as part of the themed identity of the student participants. The coded conversation about the community college student identity appeared 85 times in 13 out of 26 conversations.

The economics of the lower cost of attendance is a distinct advantage that community college students and their parents are keenly aware of. The students in the study speak openly with their families about the reality of tuition at four year public and private institutions.

Because my Mom always warns me about student debt, she's still paying off all her loans, and she was just like, you need to be smart about this. You can't just go in and pay like \$40,000 and then end up like not being able to pay it off and stuff like that." -*Phoenix*

Community college gave Phoenix the option of dealing with the personal issues that distracted her before attending college. "In 9th, 10th grade I was doing, well I was getting A's and B's but 11th and 12th it, I just started declining and stuff. Cause I was also going through a lot of things, so I wasn't really focused on work." What Phoenix was going through in high school was vital for her personal and emotional development, but it is immaterial to an open-enrollment institution like CCBTWC.

Phoenix, at to her own admission, struggled to put forward the effort to be a 3.0 student upon high school graduation. Enrolling in community college was a smart financial and academic decision. She knew that she was going to be a community college student early in her senior year. In this passage, she talks about an interaction that she had with an influential teacher that centered on her decision to attend community college.

*Phoenix:* Cause my English teacher, senior year English teacher. I did not like her cause she was like really rude. When we were doing our college like readiness stuff, all the kids who said they were going to nova she would always downgrade us. She was just like CCBTWC isn't even that good of a school, everyone who goes in there and drops out, like it's not worth it and stuff like that. She was just really rude, and everything and I really didn't like that about her

*Researcher:* Oh boy. And so you, do you think that that the English teacher would be surprised at what you just did, what you've done today?

*Phoenix:* Yeah, probably because she just had this like really bad perspective on community colleges and stuff like that. She would be just like how like those people turn into like... no awesome stuff and they just end up at these dead-end jobs getting nowhere and like

*Researcher:* Interesting, interesting if but you never, but even though you knew you were going to (community college), but you never, that never became part of what you thought of yourself. *Phoenix:* No,

*Researcher:* No. Okay.

*Phoenix:* Yeah. It inspired me to do better. That's why I see this as a chance to redeem myself actually prove that even though you go to community college, that you can still be something cause a lot of people still have that mindset of community college. Right. How bad it is. And it's only for people who did bad in high school and just need to get by.

This exchange is the most overt expression of a community college student identity in this study.

Phoenix has made sense of her election to attend community college. She knows that it is best for her finances and her personal development. Phoenix's strong academic performance in her first semester of college is an assertion of a powerful expected and future self despite the negative assertions of a disparaging teaching professional. Phoenix described her expected self as a scholar, and she sees herself as a diligent worker and task manager. She talks about her strategies for success.

Well, me putting all of my effort into my work Because, in high school I, I just would ignore homework and stuff like that. The night before it tests study for it. So that test grade would boost my overall score in the calc class. But I like study more. I do flashcards, write a lot of notes.

Students who see themselves as academic scholars also highly identified as community college students. Students who took a challenging schedule of courses in high school and were admitted to competitive four-year universities turned them down for the opportunity to attend a local college at a significantly reduced price.

*Researcher:* So, your decision to come to the community college of Booker T. Washington County and do community college is more of a financial one?

*Goose:* Yeah. A lot of people are talking a lot about how much student debt they're in nowadays...I think it was also better for me since it's close to my house

Slider talks about how he views the advantages of the community college environment, diversity of the student body, lower instructional expense, and student activities. These qualities provide Slider with opportunities to be a leader in educating his peers. The setting also facilitates instances of learning from students with different experiential and economic backgrounds. Slider's expression of his expected self delivers a descriptive illustration of interactions that feature diversity.

*Slider:* I saw people doing cool things here, and I was like, okay, community college is going to be cheaper. But also it's more likely I'm going to bump into different groups that have tested many different things—saying like, yeah, people from many different backgrounds.

*Researcher:* So that speaks towards the diversity of ideas or diversity of backgrounds. What do you think?

*Slider:* Both. I mean, I have met older gentlemen who were engineers for NASA, Lockheed, IBM, I meet them in classes. It's always interesting cause it's like, Hey, what's the best way to pursue an idea like this? You're able to talk to it with people like that. When it comes to other backgrounds, you'll bump into people who actually come from really rough backgrounds, and they'll be like, okay, I'm only pursuing this really easy major, I'm doing fine arts. Then I can throw them in and be like, Hey, you want to learn how to solder?... I would definitely say I use the diversity at this campus to get people involved in different ways.

Many of the ways that Slider is engaged with the college and the community are brought forward in this passage. Slider is a technology enthusiast; he has taught 3D Printing summer camps. He has worked as an instructor of STEM-based weekend enrichment for middle school students, and he is a central member of a local maker space. He also worked on the first 3D printer at CCBTWC and was on the leadership committee of the STEM club at CCBTWC West. Impromptu invitations, collaborative projects, and genuine learning scenarios play out around Slider in the lab setting.

The custom .stl files that Slider attempted are provided in Figures 2.10 through 2.14. The array of .stl files reflect his nebulous interests. Slider designed and fabricated the custom door stop in figure 2.12 while assisting Chipper with a project for a class assignment. He commissioned a brand new, large volume 3D Printer in an attempt to produce the largest flexible T-Rex known to 3D Printing shown in Figure 2.13. Slider also modified his personal 3d printer to be able to successfully print the rocket in Figure 2.14 using PLA, a stiff, brittle material as well as TPU, a flexible soft material that is difficult to master. All of the mentioned objects were fabricated in order to elaborate on an existing idea or provide a novelty that showcased the capabilities of the 3d printers.

Iceman's shared higher education journey was illustrative of the overwhelming value of community college education. Iceman left a four-year institution with the intention to restart his higher education: "I kind of thought of CCBTWC as a fresh start for me. The comparison between the student body at the 4-year research institution and CCBTWC yielded no real distinctions: "So I think there's a little bit of a misconception about the type of people that go to community college. It's like any other place; there are a lot of different types." During his second year at CCBTWC, Iceman had an opportunity to work with professors that he appreciated "Calc three right now it's okay, but I still think it's better set up at CCBTWC than where I was (4-year school) for the math department. I liked the calc at CCBTWC much better... Yeah, I took Dr. Farmer for Calc one and two here, and I really liked him alot."

Iceman was able to develop a strong identity through his work as a tutor on campus. High-quality math instruction was provided to Iceman. Iceman absorbed the instruction and the subjective approach for learning, and he and re-broadcast it to the students he supports in the CCBTWC tutoring center.



*Researcher:* Do you think, or have you had an experience whereby somebody maybe came to you with a problem, and you're able to help them solve the problem? Not because you knew everything, but because you knew exactly what to do?

*Iceman:* Definitely, definitely. And working in the tutoring department, especially because someone will come to you frantic about some problem or something and sometimes it can be a little bit more complex (problems). I might not know the answer. I know like the variables, and from that, I learn I can play around with it and it (can be worked out)—same thing with a lot of engineering projects. You're given big assignments that kind of look daunting at first when you try to do everything you can, and then you go to help, and then you take those steps, you realize you can, you can do a lot more than probably you thought initially.

Community college is a place where the students expand their expected selves “you are able to do more than you thought” is a sentiment that indicates newly constructed knowledge that is unexpected and has the ability to misshape the expected self.

The interviews with Iceman revealed an upgraded expected self that he is taking with him to a four-year university.

*Iceman:* I, I heard back. Uh, I got accepted to Boston Institute.

*Researcher:* Congrats!

*Iceman:* Thank you. Um, so now I have to, I haven't heard back from the other school, but honestly, for me, I think it's Jemison Tech and Boston Institute

### **Lab Setting Stimulates Knowledge Construction**

The 3D Printing lab at CCBTWC and its accompanying lab culture is the most influential environment of the study. The lab is a space where the learner and the student are on equal footing. The information that is shared about the lab experience presents evidence that students are using the lab to gain new skills and enhance old ones. The accounts given construct an understanding of an effective student-centered, peer to peer learning environment.

The student-centered nature of the lab is rooted in the 3D Printing lab culture. The labor provided comes in the form of collaboration and peer instruction. The researcher intentionally set up a peer support network in the lab to mirror the open source culture of the broader maker and

3D Printing community. Almost every problem, challenge, or capability in 3D Printing can be understood through the use of resources such as public forums and free technical information.

The culture of peer collaboration is a necessity. From a constructivist point of view, it is necessary to emphasize the reliance and efficacy of peer instruction. The lab is dominated by the influence and labor of the students who use it. The student users are simultaneously and collectively powerful. They have a demonstrated capability to raise their own funds. They support business and engineering course instruction through design and marketing seminars. They bolster engineering instruction by facilitating the completion of 3D Printed projects. They attract and train new 3D Printing practitioners in the lab through campus outreach and community events. Unlike other technical/lab settings, there appears to be little stratification between those who know and those who do not. How the students come to construct meaning in the lab is done in a collaborative way that is unique to the technical settings at CCBTWC.

An example of the palatable lab culture at CCBTWC and the substantial peer support dynamic comes from Iceman. Iceman is an engineering major who was able to use the 3D Printing lab to get enough guidance and knowledge about design software to start a personal project. In this passage, Iceman does not mention any individuals; he uses the pronoun “they” which infers a collective rather than an individual resource for knowledge. Iceman talked about wanting to learn how to design objects using a design software called Tinkercad. “When I saw they were workin’ on Tinkercad, I asked a few questions, and I said so I could design something on Tinkercad and that STL file will load up fine? And they said, sure! So I was like alright let's try it!” -*Iceman*

“Alright, let’s try it!” is a deceptively simple statement. It infers that the speaker is committed to knowledge construction and growth with little regard for the consequences.

“Alright, let’s try it!” leads to Iceman learning a new skill and applying it to digital fabrication. Before Iceman entered the room, his expected self of engineer was robust; he had skills in Math and problem solving. The knowledge he has constructed in the lab through peer support has spawned an augmentation of his expected self with the additional aspect of design skill.

The pervasive culture of peer support and instruction is what makes the lab an environmental asset different from other instructional settings. Below are excerpts that illustrate the culture of peer instruction and support in the lab. In this passage, Chipper talks about walking into the lab to start on a class project for his business class. Chipper came to the lab and received 3D design instruction on Tinkercad. After his instruction, Chipper designed a product that was going to market in a silent auction.

“So, yeah, so it was chaotic, but like, um, we made sure to get it down, and people were being like generous enough to help, you know? Cause there's still like some aspects (of 3D Printing) I don't know too much about it, so I still (was able), the people were helping me out, so we were able to come together and, make it work.

A crucial aspect of the passage shared by Chipper is his description of the support generated by his peers as generous. For Chipper, the knowledge is precious; it leads to his development of custom mini-bats that commemorate a World Series win for his home team. Generosity infers that there is value in shared knowledge. The monetary or economic value of the shared knowledge is not quantifiable. However, those involved realize that they possess knowledge that is an asset, and they freely give that knowledge to others instead of retaining or charging for it. Inside the 3D Printing lab, those without the asset of knowledge are compelled to seek it, those with the knowledge give it freely.

When a student gives knowledge to another student without monetary cost, judgment, or stratification in a collaborative environment, is that knowledge transfer different from a typical professor-student learning exchange? The Critical Constructivist paradigm requires that power

dynamics be examined in the learning process. In this passage, Stinger is talking about his involvement in Challenge Robotics. Challenge Robotics is a new branch of the 3D PARC that exists to teach “anyone who wants to know how to design and build a robot.”

Stinger came into his exploration of engineering in the latter stages of his high school career. He discovered his interest through a supportive math teacher who encouraged him to explore engineering his senior year. Stinger sought out experiences that were consistent with the study of engineering to take “full advantage” of being enrolled in college. He experienced knowledge-based stratification in his first engineering-related course, high school physics, he expected to find a similar experience in community college.

*Stinger:* For example, beforehand, if I had a question about robotics or physics, I wouldn't ask it because I was afraid of sounding stupid. But now, coming here, you know, it was a really welcoming environment. So, I found my voice in the sense that I felt like I was able to ask what I wanted and do it in a manner that that was a sort of effective in getting the answers that I wanted.

*Researcher:* Oh, I see. Wow. Well, and so welcoming environment is that, tell me about that welcoming environment idea.

*Stinger:* A lot of it has to do with, uh, just the people here. I think that Slider, uh, he was a really, really a helpful person the first time I walked in there, he was just already showing me stuff. The same thing with Goose and Maverick. They they didn't look down upon me or anything. I was new to engineering, 3D Printing, and all that stuff. So yeah, they sort of showed me the way.

Stinger “found his voice” which seems to indicate that his expected self endured some adjustments as a result of his experiences in the lab. His expected self is an advocate; his past self was not. His expected self has developed his own resources; his past self was dependent on teachers and adults.

Stinger's expected self identity as a Challenge Robotics member at CCTBWC is contributing a valuable self-advocacy capability to his future self identity as a student at Jemison Tech. Stinger's expected self is laying the foundation for his future self in instructional and practical ways. The current activity of the Challenge Robotics Team: building a go-cart is

remarkably consistent with the activities that take place at Stinger's intended transfer institution, Jemison Tech.

*Researcher:* Tell me about, tell me about the platform of, of challenge robotics in 3D Printing or club and how you feel it fits into your professional development.

*Stinger:* Uh, well I think that uh, being able to work alongside other people and like sharing ideas, you sort of just generally working on things together. You know, when we were working on the go cart, we had two people, trying to get the pieces to fit together. We had two people, which was me and Goose trying to cut the pieces. You had different people doing different things. And I think that's something that's going to be very applicable to a professional setting because not everybody works on the same thing. When I went to a trip at Jemison tech, they were talking about their formula team. They have like about 60 people in that team and they split the development of their formula cars. You have some people working on the electronics, you have other people working on fluid dynamics or thermodynamics and all of that. So, you know, things, you know, being able to get a glimpse of that experience. I think it's really shaping my experience in a professional setting.

The 3D Printing lab is a low-cost, highly effective asset that cannot exist without egalitarian, non-stratified, peer to peer instruction, and support. The effectiveness of the lab and its supportive and informative nature had a disorienting effect on study participants when they first came to the space. It would seem that the students expected a "hands off, this is too expensive for you to use experience" when they encountered the lab. The "hands off" expectations that accompanied students into the lab were refuted in short order.

I remember, being surprised that I could print here. That I wasn't even asked to bring in my own. I thought I'd be asked to bring in my own PLA. I really thought that. At GMU, for example, if it's anything, something of this scale (model of the solar system), you're asked to bring in your own PLA. -*Iceman*

I would like poke my head in, look around, and someone would just kind of just I dunno (say) what are you doing here? Right. It's just kind of like; I'm like, can I help you? But in a way that's like that, I'm not supposed to be there, but they were really open. They answered all kinds of the questions that I had, and eventually, they asked like if I could get something printed, and they said yeah. And it's slowly been working up from there. -*Wolfman*

Iceman and Wolfman's passages reinforce the unique nature of the 3D Printing Lab. They also belie the traditions of power stratification in higher education. Traditional instructional settings

insist that the learner cannot act unless the learned are present; for example, students are not allowed to go to the Biology lab to look at sample slides under a microscope without an instructor.

Iceman's quote invokes the experience of students who are obligated to pay separate fees for crucial resources like lab supplies, scantron sheets, or art materials. These payments present conscious decisions for students. They must decide whether they should pay to learn or conserve their resources for something equally or more important, a set of decisions that erode personal choice. Iceman's expected self as a student is conditioned to pay whatever costs the institution deems necessary. The 3D Printing lab operates counter to this power dynamic. The space serves as a tool to help students gain the knowledge that they see as necessary and compelling.

Cougar had a similar set of expectations upon entering the lab. The successful strategies that she used in her science classes did not initially prepare her to take advantage of the 3D Printing lab. In this conversation, she explains the difference between the two settings.

*Researcher:* So, Cougar, do you feel like maybe you come into a setting like that (the 3D Printing lab), and you maybe have a set of rules that you're applying to the setting? Does that make sense? When you come into the lab, do you have an idea about what a lab setting like that is supposed to be like?

*Cougar:* Yes, just because the lab settings I have been in are so supervised and they don't let you just kind of like (walk in), you know, this was very different.

The two lab settings are very different. In one, you can just walk in. In the other, supervision must be present for students to gain valuable knowledge and experience.

The open nature of the lab excludes the necessity of knowledge-based stratification, grading, and assessment. These qualities are central to the efficacy of the 3D Printing effect on student knowledge construction. Students who join activities within the lab are free to pursue projects and fail at them, repeatedly. In this excerpt, Maverick recalls sharing a learning

experience with the President of the 3D Printing Club. Together, they printed a miniature robot; the .stl files for the project are in figure 2.15.

Although neither of them had the knowledge to be successful with the robotics project they shared, Maverick reports gaining valuable experience: “Me and Fanboy had to sit there for hours at points. Then some days you would just get nowhere because, you know, we weren't doing the right thing. We gained a lot of experience with that. Maverick and Fanboy’s project did not wind up working for a number of reasons; the value of the project is embodied by freedom. Freedom to make mistakes and the freedom to pursue a project or not based on interest and curiosity in a risk-free environment. If Maverick’s first unsuccessful robotic experience took place on a class project or a job setting, the learning would be populated with tangible penalties.

The open nature, low obligation, penalty-free peer to peer lab environment infers something meaningful to the student participants. In this excerpt, Cougar once again explains how this is different from other environments that she has been exposed to: “And I am not quite used to that being like, Hey, like, do you know how to do this? Well, no, but I can help with it and, that was a really different environment for me. I think where I've been; it's come kind of always like every man for himself.”

The familiar disorientation invokes questioning by the participants. Is it possible that the questioning and reticence are a harbinger of a powerful learning experience? Could students being able to fill significant knowledge gaps with the help of their peers stimulate substantial changes in the possible self? Could these real-time changes be catalyzed by some sort of plausible culture shift that begins with students learning extraordinary things from other students without instructors present? The conversations in the preceding section indicate that students do

not initially see themselves as particularly essential or worthy of diverting time and expertise. The experience in the 3D Printing lab is insistently counter to that ideation.

### **3D Printing and Gender Norm Amendments**

The female participants contributed significant data about the nexus between gender identity and participation in STEM. The following section will provide examples of individual dynamics and environmental influences present in the possible self dynamics of the female participants in this study. The contributions of the female participants in the study expand upon the male contributions; many are not unique within the data set, while others indicate specific experiences occurred more often around women than men. Women in the study provided leadership, instruction, and developed skills at the same rates or higher than the men. The differences between genders were aligned with how the experiences were received. There were perception differences between men and women. There was also a difference in the rate of employment between men and women. Finally, there was a difference in socializing and perception. The differences were rooted in past experiences, demographic differences, and the lab atmosphere.

The shortage of females in the STEM fields is well understood by the federal, state, and local educational entities. The directive to increase the participation of women in the 3D PARC activities was communicated overtly by the researcher: “Well yeah, but really, you know, we're literally are not doing anything different from anybody else on the planet unless we've got women participating right now.” Meetings with the 3D PARC leadership and the programming that developed from them resulted in proposed activities that were perceived to be engaging to women. The meetings produced plans for a 3D Printed Fashion show along with a phase of 3D Printing bracelets, earrings, and accessories. These plans were conceived and executed, but they



yielded mediocre results. The attempts by the 3D PARC leadership and the 3D Printing lab to develop an exemplary nexus between gender and STEM practice were not effective.

During the study, three female students used the lab for credit coursework. One of those women purchased a 3D Printer and became a home practitioner. One female 3D PARC member attended and participated intermittently. Another female student was frequently present with a male 3D Printing technician. One female student visited the lab with the intention of using the machines to invent her own board game. One female member of the varsity robotics team came to the East Coast Reprap festival. There were three female 3D Printing technicians that were offered positions to teach at three different sites. Unfortunately, only one site started a program; therefore, only one 3D Printing employee out of six is female. Two female students contributed data to this case study.

The first female participant is Phoenix, the 3D Printing technician, and STEM tutor. Phoenix has a cache of 2 to 4 female friends that would accompany her to the lab and “hang out” during her work shifts. Throughout the study time period, Phoenix’s friends would 3D print small objects and help out with projects if asked. One female friend, in particular, took steps to inquire about being hired as a 3D Printing technician. Unfortunately, she was not eligible to work as a federal work-study.

### **Gender Norms Shaping Possible Self Dynamics**

Cougar is considering a career as a lab scientist. The Associates of Science coursework at CCBTWC is the first step in her higher education journey. The Associates of Science curriculum requires students to master a full host of scientific procedures and manual manipulations. Despite completing most of the A.S. requirements with documented success, Cougar does not see herself as particularly “good with technology.” The distinction may be due to the segmented nature of

higher education instruction. For Cougar, being good at class has not afforded transferability to technical endeavors outside of purpose-built instructional settings.

Cougar did not see herself as a person who has practical skills in the use of computers when she started her work in the 3D Printing lab: “I’m not very good with computers, nor do I have a lot of experience with it.” This theme persists in through initial interview. In this quote, Cougar is talking about her self-described poor computer acumen. She recalls a conversation that she had at an Apple store that is illustrative of her dislike for technology: “I’m not good with technology. I, if you want an example, I went to the Apple store, and the guy told me that everything that was wrong with my phone was mainly user error, not the phone's fault, my fault.” Cougar recounts this conversation with a mixture of laughter, pain, and awkwardness. Her reaction to the Apple experience is a powerful illustration of the influence that her past self has on her expected self.

Cougar intends to have a long academic career in lab science. She shares multiple instances of her past self engagement in STEM-based learning opportunities. During her interview, she shares some history of gender and how boys and girls were educated differently.

I had one class, right. It was called industrials in my old school when I was 12, maybe, and it was a coed class, and I had to take it. And being in that class, I felt like I was part of the group. But even I felt like the boys in the classroom knew a little bit more going into it just because I don't know, they're expected to, which is kind of ridiculous.

The part of this conversation that is inordinately important is that Cougar knows that her thoughts about lowered expectations based upon gender are nonsensical. Still, her lowered expectations served to impede her acceptance of her own STEM efficacy. Cougar’s narrative is illustrative of a myriad of ways that women find themselves outside of STEM-based pursuits.

Another way in which the past affected Cougar's initial interaction with the 3D Printing lab was found in her familial history. Cougar talks about her formative years and the balance between what is expected of girls versus what she was interested in learning.

Like woodwork and power tools and stuff and I've always been like, I've always wanted to learn, but unfortunately, no one really, like parents teach little boys how to do, you know, work on these things and you can teach a little girl, it's not like it's not acceptable, but usually girls have to like work for it, you know, you have to go, and they have to be proactive at it.

Cougar and Hollywood obligated themselves to use the 3D Printing lab to complete a project for an engineering class. Cougar Walks into the lab seeing herself as someone that is not good with technology, not skilled with machines, and intimidated by the environment. Cougar shared her reflections about when she first came to the lab.

*Researcher:* When we're not exposed to do these things when we were young, how do you think that that contributes to your feelings going up there (the 3D Printing lab) the first couple times?

*Cougar:* Oh, well definitely maybe scarier than it should have been

Cougar's response indicates that the scary feeling associated with interacting with technology is not logical to her. The simple act of touring the 3D Printing lab before starting a class project turned up the "heat" on outdated and impractical messages about gender that effect Cougar's expected self.

The gender representation in the 3D Printing lab environment is heavily male. Under many circumstances, a woman walking into a room full of men (US Senate, CEO executive suite, Presidency of a Community College) can be tense at first. The first moments leading up to using the machines are without a doubt full of self-conscious feelings, as Phoenix explains.

*Researcher:* It's not something that we've talked about very much, but, uh, tell me, what is your opinion about the gender dynamics around 3D Printing?

*Phoenix:* Um, it's very male-heavy as like the only girl in the lab. But I mean I don't, I can't really tell why, but I was like trying to figure that out. But I don't know. Maybe it's kind of just like intimidating maybe. I don't know. It's like when

I first got the job, and I just saw it was just guys, I was just like, I need to step it up. I thought, just don't get pushed to the side, or lost in everything. But yeah, it's very male.

Observations of Phoenix confirmed that she was determined to step it up as a 3D Printing technician. After she printed her first print, the “Pac Man ghost” Phoenix produced a Poke-ball. The .stl for the multi-part object is in figure 2.5. As Phoenix continued her tenure as a 3D Printing tech, she also revealed herself to be a 3D Printing global thinker. In order to make the efforts more broadly appealing, she made a suggestion that the researcher get 3D pens for the local science and technology expo.

During the course of the study, the researcher had arranged for Phoenix to teach STEM badge curriculum for a group of Girl Scouts. When presented with the opportunity to instruct less than 30 days after she had been hired as a 3D Printing technician, Phoenix graciously accepted the assignment. In this passage, she describes her process of taking the assignment.

*Researcher:* So in, in mid-December, you had done instruction for Cadets, Girl Scout cadets, and you did the instruction to give them a STEM badge and a robotics badge. Tell me about how that went for you. Like, let's start at the beginning. Like when I first came and told you about it, what was your impression?

*Phoenix:* I was excited about it because I do enjoy teaching kids, and then like going through it, I wouldn't like going like back and forth cause I was just like I don't really like how we're doing this. Maybe we can, cause I was trying to make it easy for them and I had a hard time doing that. Yeah. Well, like not the micro bit but like just like the design.

*Researcher:* Yeah, that was tough. It was really hard. It was really hard. Harder than I thought it would be much harder than I thought it would be.

*Phoenix:* And then like, plus I think I was also just like stressed because it was like finals week too was so like I had a lot on my plate. But yeah, I mean that was like the only problem cause then like the actual day, and it's like teaching to me it went pretty smoothly. I had a lot of fun with them. I would want them to come back. And do it. So yeah.

*Researcher:* Okay. So, so you liked doing it, you like teaching children? It was a little bit hard to kind of figure out how to get some the design thing, something that they would be that would work for them. Um, let's see here. All right, but what did you think about the fact that I came to you and said, Hey, you're going to do this.

*Phoenix:* I would say happy and shocked? Cause like it was like a responsibility. Oh, he trusts me enough to carry out this great job.

Phoenix then collaborated with the researcher to design a curriculum for robotics and STEM merit badges. As she stated, the navigation and execution of the design instruction proved itself to be rather challenging. The instructional design process was complicated by the fact that Phoenix was instructing during the finals week of her first semester in college. Despite the challenges, Phoenix was able to deliver effective Girl Scout instruction for two merit badges in one day.

The passage below indicates that Phoenix's confidence in her skills and abilities do not come close to the depth and breadth of what she actually knows. This is a quality that she shares with Cougar. In this passage, Phoenix talks about the limiting factors of some design software packages. From this conversation, it is apparent that Phoenix has more design capabilities than almost all of the male participants.

*Researcher:* Now that we are getting ready to start the semester, how have you been following with your design background? Has that been something that you've been able to, um, use the word engaged with? At all.

*Phoenix:* Cause right now, I'm learning how to use fusion 360, so I can get better at designing 3d objects and not just use Tinkercad because Tinkercad is, it's good, but it's like limited to certain things. So I kind of want it like a broader range options. So I'm just learning how to use fusion 360.

*Researcher:* When did you figure out that Tinkercad was limiting?

*Phoenix:* Um, pretty much like the first time I used it. Cause like I was kind of expecting it to be like art applications. Cause there are ones that you can like draw in 3D and stuff. So I was expecting it to be like that. But since it gives you like basic 3D shapes, you kind of have to like mold them yourself.

As a 3D PARC member, Phoenix was masterful in exercising strategies for the benefit of the lab and the student group. Phoenix's command of art and design put her in a position to contribute greatly to the learning that takes place in the lab. Despite her journeywoman status, Phoenix does not see herself as a prime contributor.

*Researcher:* So how do you see your role in the lab, and what contribution do you think you're the most proud of?

*Phoenix:* I mean, I kind of just see myself as like a helping hand, maybe like an apprentice, I am still like learning the ropes, and Stewart's taught me a lot. You've taught me a lot. Yeah, I'm just going to do it along with him.

*Researcher:* All right. It's interesting that you know, perspective is everything. My perspective on it is that Stuart is the first person that's worked in the lab that has actually 3D printed before. Otherwise, every single person who has ever worked in that lab has had zero experience and zero knowledge of 3D Printing. So, I encourage you to have, to not see yourself as an apprentice. I encourage you to, to see yourself as at least the journeymen. You know, like you were the one that printed, uh, the Disney snowflakes that actually sold, I think your Mickey snowflake sold for more than Einstein did. And I, we tried to print him like three or four times. And you won the, the competition for the number of things printed for the fundraiser.

*Phoenix:* Yes.

*Researcher:* Yeah. And, and as, and as, as it was starting to shape up when I saw the things that you were making, cause you know, I float in there, I just get, I float in there at 8:30, or 9:00 just to see what, what's processing, what's going on. And I picked up on the fact that you were printing things that were flat. And actually a couple of times I might've even taken something off the bed and started all over again. So then, once it all lined up and everybody's like, I've got this thing(s) printed and I have got that thing(s) printed,. You almost doubled everybody up. I remember distinctly thinking I was, I was walking down the hall, and I was like, wow, guys are so stupid. Like Phoenix just had the right strategy the whole time.

*Phoenix:* Yes.

*Researcher:* Was that a strategy on your part?

*Phoenix:* Yeah, Because I was just like, let me print something that prints quickly, so while I'm here, I can just get that print done. Start another one.

*Researcher:* Yeah. Yeah. And it worked.

*Phoenix:* Uh-huh, yes.

Phoenix's efforts earned her a \$25 gift certificate to Chic-Fil-et, she won a competition to see who could print the most objects for the second Christmas ornament silent auction. Phoenix, "the "apprentice" was able to easily execute a winning strategy. Her strategy was implemented without her competitors realizing that they were going to lose the competition to her. The 3D Printing exercises and events that Phoenix engaged in helped amend and re-shape her knowledge about her own skills and abilities. The new skills and abilities are crucial components of her expected and future self identity.

### 3D Lab and Gender Nexus

The lab space is novel and unorthodox. The unorthodoxy is palatable to the users. For the male patronage, it is a “tech playground.” The lower discipline demand of the 3D lab is intended to communicate the open, collaborative nature of the space. However, it did not initially prove itself to be for Cougar. Cougar talks about her first impressions and compares the lab experience, a predominantly male space to the elite level dance studio experience, a predominantly female space.

*Researcher:* I suspect that that's probably very true in the dance world.

*Cougar:* Oh yeah, yeah. No asking for help. No looking like you are asking for. You're not; I'm not. You can't look like you don't know what you're doing. And I think I do have trouble with that. I don't like asking for help.

Cougar is aware that the settings are different, and that the initial expectations that she had for the lab as an instructional space do not fit the reality. It is commendable that she would behave counter to her dance training mores and ask for help as she worked on her engineering project.

Phoenix echoes Cougar's sentiments about the “tech playground” presentation of the lab in a separate conversation.

*Phoenix:* because it maybe, I don't know, maybe if he made the lab look more welcoming cause that's like the one thing I don't like about the lab, it's just how messy it is. Even when we like do organize, like literally like next day, two days later, it's like back

There are likely a full host of reasons why the gender balance in the 3D Printing lab is heavily male; the most apparent reason is the “messy presentation” of the space. The lack of an orderly presentation was certainly not the only reason why the lab had difficulty in recruiting women. For the female participants in the study, there were no specific, succinct actions that could be recommended to stimulate an equal gender distribution.

*Researcher:* To what degree do you think that my role as the coordinator assembler of everything? How much do you think that I play into sustaining this kind of, this gender dynamic?

*Phoenix:* I don't know Because I, I was trying to think of ways that like maybe girls can be interested in it too, but then I just really couldn't cause I was just like, cause I remember you guys talked about like the fashion show and stuff and I was like, that could work. But it would have to be something really cool and amazing stuff. Cause like Stuart's showing me if he was just printing out bracelets and like personally I was just like, those aren't really that good. And so I don't know, I just really, I just can't figure it out. Just interest base and just maybe how we market the three D printing lab. But...

**3D Printing Cultivates a STEM Practitioner.** The STEM interest versus social expectation and possible self imagery was present during Cougar's first visit to the 3D Printing lab. Cougar's expected self is not good with technology, not good with computers, and not as confident in lab settings. Upon initial use of the technology, Cougar had a similar reaction to the lab that other participants have reported.

*Cougar:* And obviously I've never heard of anything, actually in the application of 3D Printing, I'd heard of 3D Printing was like in like Harvard or something.

They're printing organs and stuff like that. So that was the only knowledge I had of 3D Printing. I couldn't even fathom doing it myself, you know?

*Researcher:* Before, before this experience?

*Cougar:* Yeah. Before this experience. Like before, like before an hour ago.

Both women and men are shocked into attention by their first 3D Printing experiences. Cougar's initial reaction is typical; it reflects common themes that re-occur in first-time lab users. These themes are confusion, hesitation, and sentiments of unworthiness. What is unique between men and women is the effect of the observable demographic differences as confirmed by Phoenix "Um, it's very male heavy."

Before Cougar and Hollywood started their work in the 3D Printing lab, they took a tour of the space. During the tour, her partner, Hollywood, was substantially more enthusiastic about using the 3D Printing lab. As Cougar toured the lab with Hollywood, she stroked her long shoulder-length hair braids and checked them for split ends while she spoke about social subjects unrelated to the planned project "I don't know what I am going to wear tonight." This



observation is important to consider as she talks about walking into the lab. The scenario puts Cougar in a state of reflection about how the occupants of the lab are viewing her.

I'm not sure why that is. I'm not sure why I look like someone who wouldn't be into science or wouldn't be 3D Printing, you know? But immediately I, I do give off. I'm assuming the notion that I'm not part of (The global motion), which I, I'm not sure quite, I'm not sure if that's because I'm a woman or, You know what I mean?

It is hard to equitably discuss the dynamics of Cougar's initial stages of using the lab.

Was Cougar falling back on old behavioral patterns that distanced her from using technology?

Was Cougar's expected self resisting the lab experience by increasing her discomfort and making her self conscious? Was the omnidirectional, chaotic nature of the lab communicating messages to Cougar that were not consistent with lab settings that she is familiar with? Was Cougar not able to take the lab setting seriously without restricted access and close lab supervision? Finally, is it possible that Cougar's expected self was applying her past self experience with the knowledge that she would need "to like work for it, be proactive at it" in order to gain any meaningful knowledge? These questions become less and less significant as Cougar proceeds through her project in the lab. The lab is stimulating her as a STEM practitioner independent of formal instruction.

After the tour, the early stages of work started. The early work stage requires learners to place what is important to them over the traditional needs and responsibilities of the institutional power structures. In this passage, Cougar is struggling with redirecting the institutional resource of a 3D Printing technician to get support for her project.

*Researcher:* When you first experienced that? When somebody actually stopped whatever they were doing and helped you with something. What'd you think?

*Cougar:* It was really Surprising, but also kind of like, I don't know how to say it. Like I didn't want to receive the help. Like I was like apprehensive of it. I like, well, like, are you okay? Should you be continuing with your work?

Cougar develops a set of sophisticated methodologies to facilitate her success on the group project. The methodologies are effective, but they also required conscious effort to foster their success. Cougar assembled parts, ordered materials, executed initial quality inspections, and performed finish work with high-speed hand tools. She describes her working process and how it served to communicate competence to observers in the lab.

*Researcher:* but that feeling of “this person expects that I wouldn't know or I'm not able.” did it persist in any way?

*Cougar:* No. I would say once I kind of sat down and made my space and started working with my parts, people kind of just went, okay, then you're fine, and once I establish that kind of space of like, I know what I'm doing here, this is, I got it. Then I felt like everything kind of resumed. Like they would be working back working in their stuff, and now they're working in my stuff. And then if I asked for help, then yeah, of course, they were very helpful, but it kinda went away.

“It kinda went away.” The Printing lab and the culture it contains are open, palatable, and robust enough to help Cougar complete her project. The researcher observed the setup and implementation of Cougar's workspace. Midway through her project, Cougar was sanding a 3D printed windmill hub with a Dremel tool, the .stl files of the project are provided in figure 2.18. A Dremel tool is a hand-held milling machine that rotates metallic bits at speeds between 5,000 and 30,000 RPM. Contrary to practical logic, the slower speeds offer less predictable results than the faster ones. Cougar was issued protective goggles and gloves as well as practical instruction, and she went to work.

Midway through Cougar's project assembly, one of the 3D Printing techs was posturing to take the Dremel tool out of her hand in an effort to help her. The researcher corrected the 3D Printing tech and was adamant about the fact that this was Cougar's project and that we (technicians) are here to support production, not do it for them. The researcher also stopped Cougar's partner from trimming parts and executing finish work. The researcher asserted, “Don't do that. Cougar can do it, leave that phase alone, and work on something else project related.”

Experiences with men in the lab during the project indicate that Cougar's "space" was physical and metaphorical. Typical concerns about "doing it right" or "helping" someone without experience needed to be intentionally suspended. The men needed to respect Cougar's intention and only participate when invited.

Cougar had developed a working strategy to help her achieve a goal. The open nature of the lab allowed her to develop and sustain that working strategy. This methodology of claiming a space for oneself is not a common practice in undergraduate lab settings. The 3D Printing lab is a place where Cougar is able to achieve a significant goal using her own strategies and support from her peers. The possible self journey that paralleled the class project describes a unique experience for Women in STEM.

*Researcher:* Now, I'd like to hear your thoughts now that you've been 3D Printing  
*Cougar:* Um, I would say it's a lot easier than I thought, and obviously, we have the files done, and it's a lot easier creating your own. But I think I really thought of it as like unreachable. Like, I wouldn't even know where to start with 3D Printing, like I'm not even going to try. And when I saw the lab, I was a little overwhelmed, but when Hollywood actually showed me the process, it actually felt a lot simpler than I thought. So, I was like, Oh, maybe this could, like, this is not going to be super hard. So, I wasn't as scared to like try it out and maybe like try something else even after we're done with the wind turbine. But you know, it, it didn't feel like it was such a hard thing.

It is rewarding to report the difference in cougar's expected possible self between before engaging with 3D Printing and after. A reported possible self difference between the two happens more often to students who are less confident about their ability to use technology, like Cougar. The experience provides some insight for Cougar about her personal history and how her past self should have been more assertive in developing a familiarity with 3D Printing; she now expresses disappointment about her timing.

*Researcher:* if 16-year-old Cougar could see you doing 3Dr printing now, how would she react?

*Cougar:* Uh, I would say that she would be more encouraged to look into it and not think of it as an, again, unreachable thing... I would be more encouraged to like to start sooner because I wouldn't have even started if it wasn't for this project, you know? So I would have been really disappointed that I started up until now when I'm leaving Nova and I don't have this, like this 3D Printing lab as close to me. So, I would say she would think start sooner.

The active changes in Cougar's possible self are present throughout the data collection process. They reflect a process of knowledge construction around the expected self and increased options for the future self. In this conversation, Cougar shows signs that she understands the nature of the 3D Printing lab, but she is still hesitant.

*Researcher:* Once we get to the assembling, we realized we needed to do it first. So you got some soldering and stuff to do too now.

*Cougar:* Yeah. Yeah. Which I can't, well, let's see. I don't want to say I can't do it.

*Speaker:* No, I, I really, want to put you in position to not say that around me. Um, because you'd come along and you're doing a project with your class, and so you are, you kinda haven't been able to, to be a part of the, the kind of the; the environment that we're trying to form there. But, um, but everybody, everybody there is available to help you figure out how to learn these new skills and things of that nature. So, you don't, you shouldn't ever feel like,

*Cougar:* Like I should not ask.

When Cougar stops herself from saying, "I can't do it," she is actively revising her cache of skills that are part of her expected self. Earlier in the conversation, Cougar said she was getting accustomed to asking other students in the lab to give her pointers. She did the same for people working on their projects. Since the the lab is as a welcome place for all who enter and respect it, there are limited the power dynamics between those who "know" and those who "do not know." There is no knowledge-based stratification in the 3D Printing lab. This is likely the most important and globally applicable aspect of the space.

Cougar shares her thoughts as the project continues, her confidence in metered as she works through her process.

So after 3D Printing experiences and me knowing that, well, it obviously this is assuming that we can get the wind turbine to work, then I will know that I have

the abilities to do that, you know? And the assembly part and the electrical work is going to be what gives me that confidence and what builds that expectation later on. Well, I know I'm expected to do this, and I know I can fulfill those expectations. -*Cougar*

What is most telling about this quote is that “as long as the current project goes well,” that she will be a person who’s expected self is able to use technology to fulfill academic and professional obligations. Cougar still depends on the education system to define her skill, a pattern that is central to being “a good student.” It is also indicative of the powerlessness of the learners in higher education. Despite the power dynamics between herself and the institution, it appears as though Cougar’s possible self is changing in an encouraging way.

*Cougar:* What do I think 3D Printing done for me? I think it has broadened my horizons. I think it has not, not specifically made me more confident in my ability, but made me believe that I can be confident in abilities that I don't have yet. Do you know what I mean?

*Researcher:* Oh yeah, I do. I do. Yeah.

*Cougar:* Um, it's also made me think that technology is probably not as scary as I think it is.

Cougar can now see that there is no intimidating nature in technology; she is encouraged to return and use the lab in service of another course if possible.

I would say if any other path in my life leads me to something like this, or maybe even like later on in another class, next class, I have engineering, the next engineering class. But if they do say, well you can choose whatever project is, and I do have the knowledge of the 3D Printing lab, I will definitely come back to it just because, first of all, it was really cool. But also because you know, I know how to do it and I know that if I had to do it by myself at that point, I would be comfortable with that and even if I wasn't, I know that the environment here is very helpful.

The experience that Cougar had using 3D Printing is reflected as a part of her Future Self. In this part of the conversation, she is able to imagine how her experience in the 3D Printing is a boost to her skill set.

*Researcher:* The 3D Printing mind stone, when you see yourself after graduation, and all of your plans have worked out the way that you want. We're talking about

graduating from four-year school or even better than expected. What academic abilities had you gained command of?

*Cougar:* Well, so when I think about when I have finished school, I think more like Master's, Ph. D. So, I would say abilities to just be, to walk into a lab and know exactly what to do, you know, not feel like I need someone there to walk me through things to have like a problem. Um, as far as like, well because biomedical, so it would be like a problem in a body and me knowing exactly how we can approach it, knowing what tools I need, knowing what part of my knowledge I need. Because right now, I feel like I have a bunch of like little specks of knowledge and things, but I can't really apply them in one thing. Like I know, physics and active fixes, but I could never like build something in and apply what I know to it because you're not; I to like make bridges between everything that I've done so I can be like a full-blown professional that can do things by themselves. That's what I see.

*Researcher:* If, if I, if I could, if I can restate a little bit, it sounds like what you, what you will have gained, is the ability to go from, from theoretical to practice.

*Cougar:* Yes, that's exactly what I meant. Yes.

From this conversation, it is apparent that Cougar is aware that there are skills that she will need in her chosen profession of Biomedical Science. Her academic experience has given her a clinical understanding of the science that will help her solve patient problems. Cougar has taken two years of courses in lab science but states that she has not been able to “make bridges” between theory and practice until she worked on her project in the 3D Printing lab.

Cougar's project was objectively a success, the project was completed, and she grew academically as a STEM practitioner. Her experience and possible self dynamics paralleled vital transition processes that also occur in the natural world. When a freshwater source meets the saltwater ocean, brackish water bodies are formed. Brackish water has the qualities of salt and freshwater; it is unique unto itself with different flora, fauna, and tide conditions. In this passage, Cougar is experiencing possible self “brackish water” conditions. Her past self experienced struggled with learning STEM-based ideas as a young woman. Her future self is a highly educated lab science professional. Her expected self is developing new knowledge about her future self and is moving from the past questioning, “am I able to do it?” into the future where

she “will expect more of myself.”. This identity struggle has resolved itself and brought about a different, more confident Cougar.

*Cougar:* I guess I was never expected to learn how to do this thing (3D Printing). It is that I also didn't kind of show interest in it since I was little, but I also felt like, well, like, am I able to do it? You know, like, I don't know.

*Researcher:* Right. So you ask yourself, am I able to do it? And that question may or may not have been consciously on your mind.

*Cougar:* Yeah, a little bit.

*Researcher:* Right. But, but let's say after you've gone through this for 3D Printing, that expected concept or that expected feeling, what happened to it? What do you think has happened to that expected feeling? If I got that right.

*Cougar:* I think I will expect more of myself like as, as like as in, as far as the level of confidence.

Ultimately, Cougar contributed to one of the favorite projects of her Engineering instructor's class; her group project earned an A. It is possible to see that Cougar's previous training, her gender rigid familial experience, and her formal educational experiences have not done much for her possible self-development as a competent STEM practitioner. It is the experience in the 3D Printing lab that has helped her construct a possible self as a technician, layer by layer from the bottom up. Cougar knows that she has been through an experience to which she assigns a great deal of meaning. Cougar's experience has opened doors for her future self. To drive home the point, Cougar talks about what 3D Printing has helped her realize about herself, a young woman that is “not good” with computers.

*Researcher:* Okay, so last question. I've got the 3D printed time stone. Imagine that you have the power of time travel, and you can go back and observe yourself across time across your entire life, past, and future. Uh, what do you, tell me what to call, what events or qualities do you think that 3D Printing helps you to realize or remember about yourself?

*Cougar:* Well, yeah, that's a deep question. Well, definitely, in the profession that I chose. There's going to be a lot of hands-on work, and I think that one night when I'm looking at that part, I will be thinking that this hands-on work, this opportunity to just kind of like come in and just do the work even though I know, I know. I don't know nothing about, you know,

*Researcher:* Mmm.

*Cougar:* It really opened up the doors to- to think, well, why not? Why not try something new, you know, and you know why not get out of your comfort zone

and do something that you've never done before, and then you don't think you have the abilities for. Why not do that? So definitely professionally, I would say that's where I can see me looking back on 3D Printing and going, yeah, that was definitely the first time that I said, Oh, whatever. Let's just do it. See how it works out. And hopefully, when I look back and (on what) I used and I see that I got an A on my final, I will think, and that was successful. So why can't, you know, why shouldn't I be able to do this? You know, there's really no limit on that anymore. So, I would, that would definitely open mental barriers as well as actual physical because I won't be able to learn things.

The 3D Printing practice has granted Cougar enough confidence to take the risk of trying, attempting, perhaps even failing at things that she has no experience with. This realization is paradoxical; formal education is supposed to be full of situations that insist that students attempt things that they are not familiar with. Cougar's journey happened in an informal, peer focused, and collaborative setting. Cougar's story indicates that there is an urgent need to place free and open opportunities for STEM exploration in the hands of female students at all levels of education.

The reported experience of the two female participants in the study seems to indicate that the sentiment of “this is not for you” is felt by female technology and 3D Printing practitioners when they start their experience. The data collected also indicates that the struggle between the applicable sentiments, “this (3D Printing) is not for you” and “come play in the tech playground,” can be legitimized without conscious effort. This internal struggle is mitigated by a counterargument comprised of purposeful engagement, open access to resources, and peer-supported instruction.

### **Chapter Summary**

The purpose of this study was to describe the ways in which Community college student's possible selves are affected by the practice of 3D Printing. The .stl files provide insight into the complexity and technical aspects of producing 3D Printed models. The data examined



include the complete and incomplete .stl files as well as the possible self factors of individual identity, outside actors, and environmental influences on the possible self dynamics of the participants. Study participants reported profound differences between the possible selves before versus after engaging in 3D Printing.

Analysis of the data suggests that 3D Printing provides students with valuable experience and opportunity creating knowledge as well as assessment and improvement of existing skills. The insights that are realized through the practice of 3D Printing give students information about their current set of skills and shape opportunities for future skill development. The data collected throughout the study illustrates that community college students are aware of their strengths and weaknesses and that they possess more talents and have more abilities than they had previously considered.

3D Printing places students in a position to consider their past selves as different from their expected selves en route to developing a desired future self. The students in this study used 3D Printers as platforms to gain exposure to mechanical processes and sharpen their 3D design skills. Each student that used the 3D Printing lab to increase their skill level did so because they felt it was important to their professional skillset and personal interests. The students in the study that worked on skills that they saw as specific to engineering gained new knowledge that facilitated a future self identity that was specific and clearly focused. The way that students used 3D Printing to develop a desired future self is consistent with critical constructivism, the theoretical stance of this study.

The student's expected selves were reported as more confident and more skilled after engaging in their first 3D Printing experience. In almost every instance, the students reported a past self that was positive, surprised, or impressed with the expected self's ability to 3D Print.

Many of the student participant's reported future self ideation were reinforcing an identity of engineer upon graduation, or they were presented with a greater set of applicable skills after engaging in the practice of 3D Printing.

The participants in the study contributed substantial amounts of data regarding outside actors on their possible self development. The outside actors were very often Math instructors in high school and college. Instructors in high school and college were crucial elements of the student's possible self development. Formal instructors were usually mentioned as the first person to suggest an academic STEM pursuit for many of the study participants.

The environmental influence was an exceptionally robust factor in the reported possible self dynamics of the students in the study. The community college was the first significant environment that stimulated significant possible self ideation for the students. The most significantly influential environment of the study was the 3D Printing lab. The students used the 3D Printing lab as a space to work on skills that they thought were important, which helped them gain greater clarity on their future selves as STEM practitioners. They supported their fellow students in skill development, collaborated on significant projects, and welcomed new users with intention. The lab became a space that helped students navigate the power structures of formal education. The 3D Printing lab was in an informal setting that students used to gain valuable knowledge in a risk-free, egalitarian, and cost-free environment.

The data reported in this study through the Possible Self theoretical framework illustrate an exceptional volume of personal dynamics on the part of the participants. The students in the study were able to demonstrate knowledge about 3D Printing after having limited experience with the practice. From the very beginning of the study, it was apparent that students were active producers in their own knowledge. The fact that many of the students did not elect to 3D Print

the exact same types of objects also supports this notion. Students used the 3D Printers to make gifts, disguises, and mechanical parts for robots and electric carts. The unique deployment of the technology for individualized purposes is consistent with the theoretical stance of critical constructivism.

The 3D Printed objects that the students made also illustrate layers of constructed understanding and student empowerment. The illustrated layers of learning were observable through the fundraising activities during the study. In the Fall Semester, the 3D PARC needed to raise funds to fund their Spring programming. Two fundraising iterations took place within two weeks of each other. The first fundraiser featured 3d printed Pokemon, and the completed .stl Mickey Mouse ornament in Figure 3.7., a completed .stl of the 40-inch-tall vase Figure 3.16., a repeatedly incomplete .stl of an Einstein bust in Figure 3.10. a completed .stl of a top hat used to cover the incomplete Einstein bust in Figure 3.11., and customized Washington Nationals mini bats. The first fundraising attempt raised \$46.00 before expenses of \$39.00. The objects that sold for the highest price were the mini bats, and the 3D Printed Pokemon. The objects that the membership of the 3D PARC thought would be most valuable, the Einstein bust and the 40-inch-tall vase did not command the anticipated premium of at least a \$5.00 value of such “cool” objects.

The students in the study learned from the first fundraiser, and they considered their audience more closely as they quickly scheduled a second iteration. This time, the students used their skill in 3D design and composed unique Christmas ornaments that were based on popular culture. They returned with the Mickey Mouse themed .stl ornaments in Figure 3.8., they added character busts of Kirby (a video game hero) and Anna from the Disney movie *Frozen*. The objects that commanded the greatest prices were customized, Christmas themed Pokemon

characters, two of which sold for \$60. The changes that the students implemented worked; the second fundraiser earned \$168.00 dollars and was considered an outstanding success. The students increased their ability to fund their programming by actively learning from the disappointing results of the first auction and making changes to their product offerings. The financial success of the second fundraiser belies the existence of student empowerment and active knowledge creation in a concise set of events.

The women in the study contributed data that was parallel with the men in the study. Women reported greater self-efficacy in their technical skills. They also considered changing their career and academic focus to a STEM-based pursuit. They strongly identified with the opportunities and strengths of the community college, and the collective support that exists in the 3D Printing lab.

Women in the study reported more influential actors that were counter to their STEM identity than men. The reported past self data of the women yielded several examples of individuals and environments that worked to distance them from a functioning STEM identity. The 3D Printing lab itself was initially perceived as a space that was not supportive of their STEM identity. Despite the initial interactions, which may have been influenced by experience, the 3D Printing lab was an invaluable support to the STEM identities of the female participants. The possible self dynamics of these women were substantially influenced by the experience of 3D Printing in this study.

## **CHAPTER 5**

### **DISCUSSION**

The following chapter summarizes the research study and the important conclusions that were presented from the reported data. The chapter provides a discussion of the implications for action and recommendations for future directions.

#### **Summary of Findings**

This study was designed to describe the reported possible selves of community college students who practice 3D Printing in an informal setting. 3D Printing was chosen as the platform to explore the community college student's possible self dynamics because the technology is new. It is also inexpensive and easy to understand. The case study placed community college students in a position to use 3D printers and digital fabrication technology. They used 3D printers to fulfill occupational, academic, and extracurricular interests. Thirteen students participated in two semi-structured interviews each. The first interview was conducted when the students started 3D Printing; the second interview took place after engaging in at least six 3D printing-related activities.

The data was analyzed and arranged into two categories .stl files and possible self themes. The .stl files are a category; they help to frame the technical aspects of the student's possible self journey. The .stl files present the original intent of the 3D Printing practitioners regardless of their completion of the models. The digital files that students used also provided insight into their 3D design and manufacturing process. Digital .stl files indicate that students were pursuing a diverse set of objectives and applying informed strategies for success at specific phases of the study. The digital files also indicated that many students endeavored to produce objects of increased complexity during the time of the study.

The three possible self themes are individual identity, outside actors, and learning environment. The individual identity theme is important because the case study participants often referred to things that they had learned in their past that support their expected and future actions. Lessons learned from experience, advice, successes, and failures populated the data in this major theme. The information gathered under this theme contributed to a significant understanding of the mindset of community college students. The data indicated that in many cases, community college students are well aware of what they want to do with their futures. They are also keenly aware of their skills, abilities, and weaknesses.

The theme of outside actors presented evidence to suggest that positive interactions with community college and high school faculty heavily influence student possible self identity. Students used high school faculty to support their efforts to become STEM practitioners, and they also benefited tremendously from community college faculty advising. Finally, the influence of negative interactions was present as well. In the instances where outside actors were not encouraging or supportive, the interaction was notable. It provided students with fuel to be more motivated to produce their counterargument of future self success.

The final theme of the learning environment contained some of the most exciting results of the case study. The learning environment was a substantial contributor to student possible self identities in the case study. Specifically, the 3D Printing lab was a tremendous influence on the future possible self development of the participants. Students learned brand new skills and collaborated on design, manufacturing, and fundraising in the setting. The institution of community college itself contributed significantly to the possible self development of the students as well. Community colleges were a learning environment that provided employment, professional development, and high-quality faculty interactions.

*Possible selves* is the conceptual framework for the study. Possible selves is the label that is given to individually significant representations of the self that encompass hopes, fears, and dreams (Markus & Nurius, 1986). The possible selves framework is also supported by the viewpoint of postphenomenology (Aagaard, 2017; Aagaard et al., 2018). Postphenomenology asserts that as a person uses a technology, the capabilities of the technology change how the person thinks (Tripathi, 2016).

Research on project-based learning provides clues that a postphenomenological viewpoint modifying a possible selves framework would be a useful construct. Project-based learning asserts that students learn differently and more deeply when they apply learned concepts to solve a problem (Le Doux & Waller, 2016). The three learning theories, possible selves, postphenomenology, and project-based learning, were selected and applied. They were selected because there is little understanding of informal learning settings and how they collectively support student academic success.

Informal exploration of STEM concepts is happening all over the world in makerspaces and collaborative STEM labs. These labs are less structured settings that incubate self-directed pursuit of STEM-based projects by laypersons and citizen scientists. The maker movement is a social phenomenon that facilitates an everyday person's engagement in informal learning and technical skill acquisition. Informal education can be understood as learning that is delivered through voluntary, on-going, personalized, open-ended, and learner motivated means (Council, 2009; Kim & Dopico, 2016). This study examined what happens when community college students have the means, opportunity, and purpose of exploring technology informally in a voluntary, open-ended, and non-stratified learning setting.

## **Findings Across the Body of Research**

Research on the design of 3D printable objects by Kwon (2017) presented evidence to suggest that the act of designing digital objects was a motivational tool for students. The students in this study did not get formal design instruction. Instead, the students who built their design skillset did so to provide design instruction to other students and the surrounding community. The majority of the students used 3D models from the 3D object repository called Thingiverse. The 3D models were used to produce objects that facilitated the learning of digital fabrication processes, business, marketing, and engineering concepts. The reported activities around 3D Printing support the findings by Kwon (2017). The students in this study were motivated to learn the technology, use it for classes, and produce objects for friends and family.

The sustained effort needed to build and develop a robot from scratch was found to be most engaging for students by Arnesto (2016). Three students on the robotics challenge team built robots from scratch, but the majority of students in the study did not. All of the participants engaged in a sustained effort, even if they did not build robots from scratch. They employed sustained effort to develop curriculum for engineering projects, support student group leadership, and facilitate peer instructed projects in the lab.

The enthusiasm displayed by the participants and the resulting possible self dynamics suggest that the findings of this study are consistent with research Arnesto's (2016) results. Arnesto (2016) presented findings which support the notion that new instructional perspectives and long term projects with sustained effort are the most highly correlated with generating increased interest in STEM (Daniel, 2017a; Doerschuk, 2016; Finkel, 2017; Jen-Mei et al., 2016; Wang, 2013a).

The students who participated in this study had a full spectrum of previous engagement with STEM. Some students were STEM majors with significant higher education experience



who were preparing to transfer. Some students were social science or business majors with limited exposure to engineering and computer science concepts. Others were fully identified and moderately experienced engineering majors looking to improve their skills. The findings of the study are consistent with Papavlasopoulou, Giannakos, and Jaccheri (2017). In the current study, the learning that happened in the student-centered lab had few restrictions or qualifications to participate (Papavlasopoulou et al., 2017). The students in this study were also engaged in learning through means of which they were fully and enthusiastically in control of (Papavlasopoulou et al., 2017).

A collaboration between Goose, Viper, and Sundown developed into a large scale, problem-based learning project, their experience is consistent with problem-based learning research (Craft & Mack, 2001; Jacques et al., 2016; McGivney-Burelle & Xue, 2013; Wallace & Webb, 2016). The three of them were responsible for developing and delivering a robotics and 3D Printing curriculum in an after-school program. Collaboratively, they were tasked with the universal problem of keeping middle school children busy, engaged, and learning in a voluntary setting absent formal instruction. The three students worked together every week to provide valuable, low stakes feedback about the delivered curriculum and how to improve each subsequent session (Craft & Mack, 2001; Jacques et al., 2016; McGivney-Burelle & Xue, 2013; Wallace & Webb, 2016).

The reported possible self dynamics of the student participants presented evidence that suggested that the student-centered, welcoming, non-stratified approach to engaging students was a factor in their self-concept. Students were able to see their own previously unrecognized personal assets through their work in the lab. They attributed a greater set of enhanced skills to themselves after 3D Printing, and they reported astonishment, pride, and academic progress in

comparison to their past selves. In one instance, a woman who reported low to no computer skills acknowledged a greater computer-related skillset after 3D Printing. The possible selves framework helped students reflect on newly constructed knowledge and highlight how they had changed after using 3D printers for academic, personal, and work-related tasks.

The gender dynamics of the students also provided important data for this study. The female participants reported vastly more difficulty with accepting their own STEM identity before entering and using the 3D Printing lab. Gender was a notable difference intra-study participants; two of the thirteen participants were female. The male/female imbalance was palatable through the chaotic, playground environment manifested in the lab. The nature of the lab created a feeling of openness for the men, and a feeling of confusion and risk for the women.

The physical space of the lab was skewed towards a male preferred environment; it is a bit messy and disorganized. The male preferred environment was initially a delivery mechanism of dissuasive gender dynamics for the female participants. The difficulty was not attributed to the present day female experience in the lab. Instead, past self messages about gender from outside actors and environments were a significant influence in the initial stages of the female participant experience.

Regardless of the messages brought to light by the student past selves and lab demographics, the overwhelming champion of the study is the 3D Printing lab environment and the culture around it. The lab is modest. It has donated and inexpensive hardware; it houses students who work together to help each other solve design, fabrication, and programming problems. The 3D Printing lab is a space that “shocks” almost every student who first encounters it. Students do not have to pay to use the lab, and there are no restrictions on which students can use the space. In the lab, knowledge-based stratification is useless; new users are as valuable as

experienced ones. The extraordinary space proved itself to be just one of the very effective tools that students used to gain critical knowledge and construct new understanding.

The students gained critical knowledge as a part of a larger pattern of navigating institutional power structures (Christensen, 2008; Eshach, 2007). The lab is a rather brilliant work-around for aspiring engineers. This was among the most surprising patterns that emerged from the findings. Most of the students who employed the lab were engineering majors who used the lab to gain skills that they had not gotten from their formal instruction in high school or college.

These engineering majors used the 3D Printing lab as a resource to conduct informal, self-directed study to gain the skills that they thought were necessary. Doing so instituted new knowledge creation and brought more detail to their future selves as engineers. This emerged as an established pattern along with seeking supplemental help in Mathematics, and engaging in STEM extra-curricular activities.

The US community college system is an instructional provider for more than half of all women and students from diverse backgrounds who enter the STEM fields (National Center for Education & Institute of Education, 2019). Statistically, the group of students who participated in the study was a majority-minority population. The results of the study suggest that 3D Printing could be a tool for increasing the number of students from diverse backgrounds who will graduate with an Associate of Science in Science Technology Engineering and Math disciplines.

### **Facilitating Gender Diversity**

The inaction of outside actors was crucial to female participant's possible self development. For women, outside actors such as project partners, the 3D Printing technicians, and 3D Printing lab managers needed to be intentionally passive. The male outside actors needed

to “stay in their lane” for the duration of the project. Doing so meant not offering support unless invited to do so. The experience can be re-imagined as a right-handed person being observed using a left-handed pair of scissors when the correctly designed scissors are in front of them. Under most circumstances, a helpful outside actor (technician, project partner, or manager) would redirect to the correct scissors and perhaps demonstrate their operation. The demonstrated efficacy of the female student experience in this study suggests that uninvited interventions are not the right approach to facilitating compelling STEM experiences for women.

The data presented in this study indicate that males need to be of service only when women prescribe it. The ability to work on a project and learn from the process, which includes mistakes, is not available in credit coursework and is typically eroded from women. STEM educators should examine the opportunities and modalities in which women are allowed to learn from experience as they aim to increase the participation of women in STEM. This would likely benefit all STEM practitioners.

Female case study subjects created an environment within an environment. A female participant was able to be optimally productive and in control within her workspace. She was in control of whom she gave help to and whom she solicited help from. The 3D Printing lab was a pragmatic platform for female participants' possible self development as STEM practitioners. This is a notable finding; it illustrates the utility of female-focused STEM programming in higher education.

Reflecting on the female possible self dynamics uncovers several individual insights that can be generalized to the pursuit of STEM expertise. The first generalizable insight is that all participants and, in particular, women bring a lifetime of experience to the education setting. Female case study participants expressed some conflict with what is expected of women versus

what women allow themselves to do. Second, without the overt, intentional, and expected emphasis placed on peer support, respect for personal working space, and gender equity in the 3D Printing lab, there may have been no amended or changed possible self identities for the female participants.

### **Future Steps**

The reported experiences of the students in the study support the body of research around problem-based learning, possible selves, and postphenomenology. There is evidence to suggest that 3D Printing can be a useful tool in supporting engineering students and creating STEM interest in talented non-STEM majors. Futures steps should be directed at attempting to test the utility of 3D Printing in other community college settings.

While there are many community colleges with 3D Printing labs, it is unknown what the structures of those labs are. To that end, it is necessary to set up and explore 3D Printing spaces at a host of institutions. These 3D Printing spaces must be student-led, focused on attracting women to STEM, and populated with inexpensive hardware to encourage student exploration. Launching a series of 3D Printing spaces such as these would help determine if the results of this study are unique and isolated to CCBTWC or whether they transcend across participant populations.

Another recommended future direction is to fully integrate engineering majors into the current and future 3D Printing space. The students in this study were adamant about the fact that they had shortcomings; they felt more comfortable addressing them in a risk-free student-centered environment. They used the space to learn how to program computers, build mechanical machines, and sharpen their design skills.

The engineering students in this study used the lab to create their own understanding of these subjects. The created knowledge served to refine and sharpen their future self identity. This pattern was well established and almost universal. The data from this case study suggests that 3D Printing is a powerful tool for STEM-based learning and identity construction. If 3D Printing were fully integrated into community college engineering departments, more students would be able to follow suit.

Steps should be taken towards increasing the number of students who use 3D Printing in community colleges across the world. In almost every instance, students who participated in this case study presented a viewpoint consistent with an incremental intelligence paradigm (Rattan et al., 2012). Applied more broadly in community college, extending the number of 3D Printing practitioners could result in a more significant population of students who come to believe that they can learn and innovate using a cutting edge technology. This improvement to the student body would be achievable with little to no instructional time or supervision from busy, overstretched faculty.

Another future step to be considered is the development of a standardized set of 3D printable machines that communicate crucial engineering concepts through project-based learning. This set of machines would be known as an engineering “reader.” An engineering reader is a tool that students can use to become acquainted with the engineering and computer science disciplines and concepts. Such a reader would be comprised of simple to understand objects and systems that can be 3D printed. Upon completion of the reader projects, a student will develop a project-based experience to understand concepts such as friction, mass, and density through a low-risk, project-based learning delivery. A well-conceptualized reader would

allow for someone who is in developmental math, or in another field of study to consider majoring in engineering.

The gender dynamics that were exposed in this study were surprising. The reported lack of confidence-building, hands-on opportunities that are available to women seems callous and outdated. Future iterations of a student-centered lab should be designed by women to address the gender dynamics of commanding technology. The female-oriented design must assume any form deemed necessary by the female students and faculty involved with the setup. Every possibility from the genius to the sublime must be considered in setting up such a space.

After commissioning, the female orientation of the space must be preserved and respected through the life of the lab. Such a directive is necessary; there are not enough female community college graduates with Associate of Science degrees in the lab sciences, engineering, or computer science (NSF, 2015). Such a directive is also optimal; it is possible that a space that is designed by women, for women, could incubate new forms of STEM understanding for all students.

### **Concluding Remarks**

Science Technology Engineering and Math (STEM) are gateways to high paying, in-demand jobs in the United States and across the globe. The higher education system consistently underproduces the number of STEM graduates needed to fill all of the available positions that require formal lab science education. Non-profits, government agencies, and public education systems continue to try and address the shortfall in a number of ways. The results of these efforts are encouraging, the actual number of women and students from diverse backgrounds who are graduating with STEM degrees has increased over the last three decades, but the proportion of STEM professionals from diverse backgrounds and women is still unacceptably low.

Community college is the most substantial new market for the development of STEM college graduates. Community colleges are the institution of choice for over 2 million African American and Hispanic students and 3 million women. It is not necessary to place these students on a formal track or stratify them through curricular mechanisms to grow the ranks of STEM practitioners. Instead, what is needed is to provide these students with a STEM *tabula rosa*, a platform upon which they can project and elevate an identity of STEM practitioner. Open-source 3D Printing and emerging technologies provide such a platform with a highly effective, and exceptionally useful format. Community college STEM practitioners who use 3D Printing to fulfill academic, social, and occupational obligations produce outsized, tangible results. Student-centered 3D Printing options should be introduced into community colleges immediately and without delay. The technology is embarrassingly inexpensive, it benefits the student body, the surrounding community, and it helps students from diverse backgrounds and women develop strong identities as STEM practitioners.



## References

- Aagaard, J. (2015). Drawn to distraction: A qualitative study of off-task use of educational technology. *Computers & Education*, 87, 90-97. doi:10.1016/j.compedu.2015.03.010
- Aagaard, J. (2017). Introducing postphenomenological research: A brief and selective sketch of phenomenological research methods. *International Journal of Qualitative Studies in Education (QSE)*, 30(6), 519-533. doi:10.1080/09518398.2016.1263884
- Aagaard, J., Friis, J. K. B. O., Sorenson, J., Tafdrup, O., Hasse, C., & Ihde, D. (2018). *Postphenomenological methodologies new ways in mediating techno-human relationships*: Lanham, Maryland : Lexington Books.
- Amelink, C. T., Artis, S., & King Liu, T.-J. (2015). Examining the self-efficacy of community college stem majors: Factors related to four-year degree attainment. *Community College Journal of Research and Practice*, 39(12), 1111-1124.  
doi:10.1080/10668926.2014.941514
- Archer, L., Dawson, E., Seakins, A., & Wong, B. (2016). Disorientating, fun or meaningful? Disadvantaged families' experiences of a science museum visit. *Cultural Studies of Science Education*, 11(4), 917-939. doi:10.1007/s11422-015-9667-7
- Armesto, L., Fuentes-Durá, P., & Perry, D. (2016). Low-cost printable robots in education. *Journal of Intelligent & Robotic Systems*, 81(1), 5-24. doi:10.1007/s10846-015-0199-x
- Ash, J. (2012). Technology, technicity, and emerging practices of temporal sensitivity in videogames. *Environment and Planning A*, 44(1), 187-203. doi:10.1068/a44171
- Ashley, S. (1995). Rapid prototyping is coming of age. *Mechanical Engineering*, 117(7), 62.
- Attaran, M., & Stidham, P. (2017). The coming age of 3-d printing. *ISE*, 49(4), 26-31.
- Bailey, T. R. (2015). *Redesigning america's community colleges a clearer path to student success*. Cambridge, Massachusetts: Harvard University Press.

- Bettinger, E. P., & Long, B. T. (2009). Addressing the needs of underprepared students in higher education. *Journal of Human Resources, 44*(3), 736-771. doi:10.3368/jhr.44.3.736
- Birtchnell, T. (2016). A new industrial future? 3D Printing and the reconfiguring of production, distribution, and consumption. In J. Urry (Ed.), *Antinomies*: London, England New York, New York : Routledge.
- Birtchnell, T., Böhme, T., & Gorkin, R. (2017). 3D Printing and the third mission: The university in the materialization of intellectual capital. *Technological Forecasting & Social Change, 123*, 240-249. doi:10.1016/j.techfore.2016.03.014
- Caffrey, T., & Wohlers, T. (2015). Additive manufacturing state of the industry. *Manufacturing Engineering, 154*(5), 67-78.
- Caplan, A. J., & MacLachlan, E. S. (2014). An overview of undergraduate research in the cuny community college system.
- Chan, H.-y., & Wang, X. (2016). Interact for what? The relationship between interpersonal interaction based on motivation and educational outcomes among students in manufacturing programs at two-year technical colleges. *Community College Review, 44*(1), 26-48. doi:10.1177/0091552115612560
- Christensen, T. K. (2008). The role of theory in instructional design: Some views of an id practitioner. *Performance Improvement, 47*(4), 25-32. doi:10.1002/pfi.199
- Chrstidou, V. (2011). Interest, attitudes and images related to science: Combining students' voices with the voices of school science, teachers, and popular science. *International Journal of Environmental Science Education, 6*(2), 141-159.
- Council, N. R. (2009). *Learning science in informal environments: People, places, and pursuits*. Washington, DC: The National Academies Press.

Craft, E. L., & Mack, L. G. (2001). Developing and implementing an integrated, problem-based engineering technology curriculum in an american technical college system. *Community College Journal of Research & Practice*, 25(5/6), 425-439.

doi:10.1080/106689201750192274

Creech, A., Hallam, S., Varvarigou, M., Gaunt, H., McQueen, H., & Pincas, A. (2014). The role of musical possible selves in supporting subjective well-being in later life. *16*, 32-49.

doi:10.1080/14613808.2013.788143

Daniel, K., Mishra, C. (2017a). Student outcomes from participating in an international stem service-learning course. *SAGE Open, January-March 2017*, 1-11.

doi:d0o.i.1o1rg7/71/02.1157872/241450812474609171659751

Daniel, K., Mishra, C. (2017b). Student outcomes from participating in an international stem service-learning course. *SAGE Open, January-March 2017*, 1-11.

doi:d0o.i.1o1rg7/71/02.1157872/241450812474609171659751

Doerschuk, P. B., Cristian ; Daniel, Jennifer ; Kruger, Joseph ; Mann, Judith ; Martin, Cristopher. (2016). Closing the gaps and filling the stem pipeline: A multidisciplinary approach.

*Journal of Science Education and Technology*, 25(4), 682-695. doi:10.1007/s10956-016-9622-8

Dubriwny, N., Pritchett, N., Hardesty, M., & Hellman, C. (2016). Impact of fab lab tulsa on student self-efficacy toward stem education. *Journal of STEM Education : Innovations and Research*, 17(2), 21-25.

Duncan, J. R., Zeng, Y. (2005). Women: Support factors and persistence in engineering.

*National Center for Engineering & Technology Education (NCETE)*.

- Eshach, H. (2007). Bridging in-school and out-of-school learning: Formal, non-formal, and informal education. *Journal of Science Education and Technology*, 16(2), 171-190.  
doi:10.1007/s10956-006-9027-1
- Feinstein, N. W. (2017). Equity and the meaning of science learning: A defining challenge for science museums. *Science Education*, 101(4), 533-538. doi:10.1002/sce.21287
- Finkel, L. (2017). Walking the path together from high school to stem majors and careers: Utilizing community engagement and a focus on teaching to increase opportunities for urban students. *Journal of Science Education & Technology*, 26, 116-126.  
doi:10.1007/s10956-016-9656-y
- Flanigan, A. E., Peteranetz, M. S., Shell, D. F., & Soh, L.-K. (2017). Implicit intelligence beliefs of computer science students: Exploring change across the semester. *Contemporary Educational Psychology*, 48, 179-196.  
doi:<https://doi.org/10.1016/j.cedpsych.2016.10.003>
- Fong, C. J., Davis, C. W., Kim, Y., Kim, Y. W., Marriott, L., & Kim, S. (2017). Psychosocial factors and community college student success. *Review of Educational Research*, 87(2), 388-424. doi:10.3102/0034654316653479
- Go, J., & Hart, A. J. (2016). A framework for teaching the fundamentals of additive manufacturing and enabling rapid innovation. *Additive Manufacturing*, 10(Supplement C), 76-87. doi:<https://doi.org/10.1016/j.addma.2016.03.001>
- Hachey, A. C., Conway, K. M., & Wladis, C. W. (2013). Community colleges and underappreciated assets: Using institutional data to promote success in online learning. *Online Journal of Distance Learning Administration*, 16(1), 1-18.

- Hays, D. G. (2012). *Qualitative inquiry in clinical and educational settings*. New York: New York : Guilford Press.
- Hoffman, E., Starobin, S., Laanan, F., & Rivera, M. (2010). Role of community colleges in stem education: Thoughts on implications for policy, practice, and future research. *Journal of Women and Minorities in Science and Engineering*, 16, 85-96.  
doi:10.1615/JWomenMinorScienEng.v16.i1.60
- Honma, T. (2017). Advancing alternative pathways to science: Community partnership, do-it-yourself (diy)/do-it-together (dit) collaboration, and stem learning "from below". *Transformations: The Journal of Inclusive Scholarship and Pedagogy*, 27(1), 41-50.  
doi:10.1353/tnf.2017.0004
- Horowitz, S. S., & Schultz, P. H. (2014). Printing space: Using 3D Printing of digital terrain models in geosciences education and research. *Journal of Geoscience Education*, 62(1), 138-145. doi:10.5408/13-031.1
- Jackson, P. A., & Seiler, G. (2013). Science identity trajectories of latecomers to science in college. *Journal of Research in Science Teaching*, 50(7), 826-857. doi:10.1002/tea.21088
- Jackson, P. A., & Seiler, G. (2017). Identity work in the college science classroom: The cases of two successful latecomers to science. *Science Education*, 101(5), 716-740.  
doi:10.1002/sce.21290
- Jacques, S. b., Bissey, S. b., & Martin, A. (2016). Multidisciplinary project based learning within a collaborative framework: A case study on urban drone conception. *International Journal of Emerging Technologies in Learning (iJET)*, 11(12), 36-44.

- Jen-Mei, C., Chuhee, K., Stevens, L., & Buonora, P. (2016). Strategies to recruit and retain students in physical sciences and mathematics on a diverse college campus. *Journal of College Science Teaching*, 45(3), 14-22.
- Jones, R., Haufe, P., Sells, E., Irvani, P., Olliver, V., Palmer, C., & Bowyer, A. (2011). Reprap ??? The replicating rapid prototyper. *Robotica*, 29(1), 177-191.  
doi:10.1017/S026357471000069X
- Kerrigan, M. R. (2015). Social capital in data-driven community college reform. *Community College Journal of Research & Practice*, 39(7), 603-618.  
doi:10.1080/10668926.2013.866061
- Kim, M., & Dopico, E. (2016). Science education through informal education. *Cultural Studies of Science Education*, 11(2), 439-445. doi:10.1007/s11422-014-9639-3
- Kincheloe, J. L. (2005). From constructivism to critical constructivism (pp. 1-40).
- Kolko, B., Hope, A., Sattler, B., Maccorkle, K., & Sirjani, B. (2012). Hackademia: Building functional rather than accredited engineers (Vol. 1, pp. 129-138).
- Kullman, K. (2016). Prototyping bodies: A post-phenomenology of wearable simulations. *Design Studies*, 47, 73-90. doi:10.1016/j.destud.2016.08.004
- Kwon, H. (2017). Effects of 3D Printing and design software on students\u2019 interests, motivation, mathematical and technical skills. *Journal of STEM Education*, 18(4).
- Kwon, Y., Lee, Y.-A., & Kim, S. (2017). Case study on 3D Printing education in fashion design coursework. *Fashion and Textiles*, 4(1), 1-20. doi:10.1186/s40691-017-0111-3
- Lai, M., Luong, D., & Young, G. (2015, 2015). *A study of kinesthetic learning activities effectiveness in teaching computer algorithms within an academic term*, Athens.

- Landivar, L. C. (2013). Disparities in stem employment by sex, race, and hispanic origin. In i. b. U.S. Census Bureau & S. American Community (Eds.): Washington, D.C. : U.S. Department of Commerce, Economics and Statistics Administration, U.S. Census Bureau.
- Le Doux, J. M., & Waller, A. A. (2016). The problem solving studio: An apprenticeship environment for aspiring engineers. *Advances in Engineering Education*, 5(3), 1-27.
- Lee, J., Husman, J., Scott, K. A., & Eggum-Wilkens, N. D. (2015). Compugirls: Stepping stone to future computer-based technology pathways. *Journal of educational computing research*, 52(2), 199-223. doi:10.1177/0735633115571304
- Leslie, S.-J., Cimpian, A., Meyer, M., & Freeland, E. (2015). Expectations of brilliance underlie gender distributions across academic disciplines. *Science*, 347(6219), 262-265. doi:10.1126/science.1261375
- Maloy, R., Trust, T., Kommers, S., Malinowski, A., & LaRoche, I. (2017). 3D modeling and printing in history/social studies classrooms: Initial lessons and insights. *Contemporary Issues in Technology and Teacher Education*, 17(2), 229-249.
- Markus, H., & Nurius, P. (1986). Possible selves. *American Psychologist*, 41(9), 954-969. doi:10.1037/0003-066X.41.9.954
- Martin, M., and Simmons. (2014). Exploring the theoretical social capital "deficit" of first generation college students: Implications for engineering education. *International Journal of Engineering Education*, 30(4), 822-836.
- Mason, R., & Cooper, G. (2013). Mindstorms robots and the application of cognitive load theory in introductory programming. *Computer Science Education*, 23(4), 296-314. doi:10.1080/08993408.2013.847152

- McGivney-Burelle, J., & Xue, F. (2013). Flipping calculus. *PRIMUS*, 23(5), 477-486.  
doi:10.1080/10511970.2012.757571
- Melguizo, T., & Wolniak, G. C. (2011). The earnings benefits of majoring in stem fields among high achieving minority students. *Research in Higher Education*, 53(4), 383-405.  
doi:10.1007/s11162-011-9238-z
- Meyer, M., Hax, S. (2014). Engineering dropouts: A qualitative examination of why undergraduates leave engineering. *Journal of Engineering Education*, 103(4), 525–548.  
doi:10.1002/jee.20054
- Morgan, A. J. L., Jose, L. H. S., Jamieson, W. D., Wymant, J. M., Song, B., Stephens, P., . . . Castell, O. K. (2016). Simple and versatile 3D printed microfluidics using fused filament fabrication. *J PloS one*, V 11 4.
- National Center for Education, S., & Institute of Education, S. (2019). Digest of education statistics (online)digest of education statistics [electronic resource]. *Digest of education statistics*.
- National Center for Education, S., United States. Office of Educational, R., Improvement. Center for, S., United States. Office of Educational, R., Improvement. Center for Education, S., & Institute of Education, S. (2016). Digest of education statistics. *Digest of education statistics*.(52).
- Newman, J. L., Dantzler, J., & Coleman, A. N. (2015). Science in action: How middle school students are changing their world through stem service-learning projects. *Theory Into Practice*, 54(1), 47-54. doi:10.1080/00405841.2015.977661



- NSF, N. S. F. (2015). *Women, minorities, and persons with disabilities in science and engineering: 2015. Special report nsf 15-311*. Retrieved from Arlington, VA: <http://www.nsf.gov/statistics/wmpd/>
- NSF, N. S. F. (2017). *Women, minorities, and persons with disabilities in science and engineering: Special report nsf 17-310*. Retrieved from Arlington, VA:
- Oyserman, D., Bybee, D., Terry, K., & Hart-Johnson, T. (2004). Possible selves as roadmaps. *Journal of Research in Personality, 38*(2), 130-149. doi:10.1016/S0092-6566(03)00057-6
- Oyserman, D., & Markus, H. R. (1990). Possible selves and delinquency. *Journal of Personality and Social Psychology, 59*(1), 112-125. doi:10.1037/0022-3514.59.1.112
- Ozaki, C. (2016). Possible selves, possible futures. *Journal of College Student Retention: Research, Theory & Practice, 17*(4), 413-436. doi:10.1177/1521025115579248
- Papavlasopoulou, S., Giannakos, M. N., & Jaccheri, L. (2017). Empirical studies on the maker movement, a promising approach to learning: A literature review. *Entertainment Computing, 18*, 57-78. doi:<https://doi.org/10.1016/j.entcom.2016.09.002>
- Rameygassert, L. (1996). Same place, different experiences: Exploring the influence of gender on students' science museum experiences. *International Journal Of Science Education, 18*(8), 903-912. doi:10.1080/0950069960180803
- Rattan, A., Good, C., & Dweck, C. S. (2012). “It's ok — not everyone can be good at math”: Instructors with an entity theory comfort (and demotivate) students. *Journal of Experimental Social Psychology, 48*(3), 731-737. doi:<https://doi.org/10.1016/j.jesp.2011.12.012>

- Roshandel, S., & Hudley, C. (2018). Role of teachers in influencing the development of adolescents' possible selves. *Learning Environments Research*, 21(2), 211-228.  
doi:10.1007/s10984-017-9247-8
- Saldaña, J. (2013). *The coding manual for qualitative researchers* (2nd ed.. ed.). Los Angeles: Los Angeles : Sage.
- Seidman, I. (2013). *Interviewing as qualitative research a guide for researchers in education and the social sciences* (4nd ed.. ed.). New York: New York : Teachers College Press.
- Simpson, T. W., Williams, C. B., & Hripko, M. (2017). Preparing industry for additive manufacturing and its applications: Summary & recommendations from a national science foundation workshop. *Additive Manufacturing*, 13, 166-178.  
doi:<https://doi.org/10.1016/j.addma.2016.08.002>
- Smith, C., & Wingate, L. (2016a). Strategies for broadening participation in advanced technological education programs: Practice and perceptions. *Community College Journal of Research and Practice*, 40(9), 779-796. doi:10.1080/10668926.2015.1108252
- Smith, C., & Wingate, L. (2016b). Strategies for broadening participation in advanced technological education programs: Practice and perceptions. *Community College Journal of Research & Practice*, 40(9), 779-796. doi:10.1080/10668926.2015.1108252
- Smith, K., & Hughes, W. (2013). Parabolic mirror focusing on science, technology, engineering, and math. *Technology and Engineering Teacher*, 73(3), 36-39.
- Sprinthall, R. C. (2012). *Basic statistical analysis*. Boston: Pearson Allyn & Bacon.
- Steinberg, S. R., & Kincheloe, J. L. (2010). Power, emancipation, and complexity: Employing critical theory. *Power and Education*, 2(2), 140-151. doi:10.2304/power.2010.2.2.140

- Stevenson, J., & Clegg, S. (2011). Possible selves: Students orientating themselves towards the future through extracurricular activity. *37*, 231-246. doi:10.1080/01411920903540672
- Strawn, C., & Livelybrooks, D. (2012). A five-year university/community college collaboration to build stem pipeline capacity. *Journal of College Science Teaching*, *41*(6), 47-51.
- Tripathi, A. K. (2016). Culture of sedimentation in the human-technology interaction. *Ai & Society*, *31*(2), 233-242. doi:10.1007/s00146-015-0581-z
- Trust, T., & Maloy, R. (2018). *Teacher pd for emerging technologies: 3D Printing projects & makerspaces*. Paper presented at the Society for Information Technology & Teacher Education International Conference 2018, Washington, D.C., United States.  
<https://www.learntechlib.org/p/182693>
- Trust, T., Maloy, R. W., & Edwards, S. (2018). Learning through making: Emerging and expanding designs for college classes. *TechTrends*, *62*(1), 19-28. doi:10.1007/s11528-017-0214-0
- Vakharia, V. N., Vakharia, N. N., & Hill, C. S. (2016). Review of 3-dimensional printing on cranial neurosurgery simulation training. *World Neurosurgery*, *88*, 188-198.  
doi:<https://doi.org/10.1016/j.wneu.2015.12.031>
- Wallace, M. F. G., & Webb, A. W. (2016). In the midst of a shift: Undergraduate stem education and "pbl" enactment. *Journal of College Science Teaching*, *46*(2), 47-55.
- Wang, X. (2013a). Modeling entrance into stem fields of study among students beginning at community colleges and four-year institutions. *Research in Higher Education*, *54*(6), 664-692. doi:10.1007/s11162-013-9291-x
- Wang, X. (2013b). Modeling entrance into stem fields of study among students beginning at community colleges

- and four-year institutions. *Research in Higher Education*, 54(6), 664-692. doi:10.1007/s11162-013-9291-x
- Wang, X. (2013c). Why students choose stem majors: Motivation, high school learning, and postsecondary context of support. *American Educational Research Journal*, 50(5), 1081-1121. doi:10.3102/0002831213488622
- Windsor, A., Russomanno, D., Bargagliotti, A., Best, R., Franceschetti, D., Haddock, J., & Ivey, S. (2015). Increasing retention in stem: Results from a stem talent expansion program at the university of memphis. *Journal of STEM Education : Innovations and Research*, 16(2), 11-19.
- Wohlers, T. G., T. (2016). History of additive manufacturing. *Wohlers Report*, 1-38.
- Wood-Black, F., & Pasquarelli, T. (2005). Don't try this at home or even in the classroom! *Chemical Health and Safety*, 12(2), 35-35. doi:10.1016/j.chs.2005.01.005
- Yi-Hsuen, S., & Min, L. (2007). The importance of emotional usability. *Journal of Educational Technology Systems*, 36(2), 203-218. doi:10.2190/ET.36.2.h
- Yowell, C. M. (2002). Dreams of the future: The pursuit of education and career possible selves among ninth grade latino youth. *Applied Developmental Science*, 6(2), 62-72. doi:10.1207/S1532480XADS0602\_2

## Appendix A

### 3D Printing Interview Questions

Interview questions:

[Opening rapport building questions.]

I'd like to get to know more about you:

1. How is college going for you so far?
  - a. What majors have you considered?
  - b. Have you settled on a major?
    - i. (If yes) What do you hope being [major] means for your future?
    - ii. (In no) What has been difficult about settling on a major?
2. How would you describe yourself as a student back in high school?
  - a. What were some of your favorite classes or teachers?
  - b. What were some of your favorite activities in- and out-of-school?
  - c. How do you think you've changed since high school?
3. Describe how you decided to enroll at [college]?
4. How would your family and friends from high school describe your process of becoming a college student?
5. What has been your experience in mathematics, computer science, or engineering courses [in high school or college]? [Explore each experience mentioned.]

#### **Now I would like to learn more about your thoughts about the future:**

1. If everything turned out well for you and you achieved your dreams, what do you hope to become in terms of your career?
2. If everything took a turn for the worse and your dream to become a [career] did not work out, what do you think you would do?
3. How likely do you believe that you will achieve your dream to become a [career]?
4. What do you think will make the difference whether you are able to achieve your dream to become a [career] or not?
5. Do you see yourself using technology as a [career]?
  - a. (If yes) How do you feel about the possibility of using technology as a [career]?
  - b. (If yes) Have you always felt this way about using technology?
  - c. (If yes) What experiences shaped how you feel about using technology?

#### **3D Printing related questions:**

1. I'd like to hear your thoughts now that you have been 3D Printing.
2. If you could go back five years and see yourself using 3D Printing technology today, how do you think you would react?
3. We have a 3D PARC fundraiser in March. It will be a fashion show on campus; our students will learn how to design and display 3D printed fashion that is achievable for both our machines and our design skills. Some examples include key rings, belt buckles, hats, crock embellishments, cufflinks. All of these examples can easily be designed, manufactured, and sold just like what you have made here. How do you see

yourself contributing to the fashion show? Would you design, model, manufacture, promote, or do technical support?

Data documentation:

What are the activities participated, in and what are the objects that were made by the students in the 3D Printing lab?

This data is collected with photographic evidence; there are also digital representations of the models that are made preserved on the hard drives of the computers that generate the 3D models.

End Interview more than five interventions

What 3D PARC programming or events did you attend?

This is a 3D printed Infinity Gauntlet; it represents the power of digital fabrication for you. I want you to put this on; we will add one stone at a time, and with each stone, there is a concurrent power that coordinates with the questions that I am asking, it will help you visualize things are we go along.

1. The 3D Printing Reality stone: When you look at yourself and what you are capable of doing with this technology today, what has 3D Printing done to or for you?
2. The 3D Printing Power stone: When you look at yourself after this academic year, are you on the same trajectory as you were when this year started?
3. The 3D Printing Mind stone: When you see yourself after graduation and all of your plans have worked out the way that you want, or even better than expected, what academic abilities have you gained command of? Is that different in any way from when you first entered college?
4. 3D Printing Soul stone: Imagine that you needed to cast all of your college credits and everything that you have learned off of a cliff in order to get this stone, and none of your plans to use your mind to make a better future have worked out. What do you fear about that future, what does it look like?
5. The 3D printed Time stone: Imagine that you have the power of time travel, you can go back and observe yourself, tell me what events or qualities 3D Printing helped you remember?

## Appendix B

### Research Participant Information and Consent Form

Dear Participant:

The purposes of this form are to give you information that may affect your decision whether to say YES or NO to participation in this research and to record the consent of those who say YES. You are being asked to participate in a research project. Researchers are required to provide a consent form to inform you about the study, to convey that participation is voluntary, to explain risks and benefits of participation, and to empower you to make an informed decision. You should feel free to ask the researchers any questions you may have.

Study Title: *Possible Self Dynamics of Community College Students Engaged in 3D Printing in Informal Environments*

Primary Investigator: Chris R. Glass, Ph.D., Associate Professor, College of Education, Department of Educational Foundations and Leadership, Old Dominion University

Investigator: Lawrence Nightingale, Doctoral Student, College of Education, Department of Community College Leadership, Old Dominion University

#### PURPOSE OF RESEARCH:

As a community college student, you are being asked to participate in a research study exploring the experiences of students who participate in 3D Printing. In order to participate you will need to consent to two interviews. The first interview will be general, it will explore your educational experience and plans for the future. The second interview will take place after you have attended a number of 3D Printing and Robotics Programs and continued to use the 3D Printing lab to complete projects. The second interview will feature a researcher provided Infinity Gauntlet, and will be about your present, future, and feared possible selves. The study, named *Possible Self Dynamics of Community College Students Engaged in 3D Printing in Informal Environments* is led by Dr. Chris Glass.

#### WHAT YOU WILL DO:

Each interview will last approximately 60 minutes. The first interview will be conducted in an empty classroom or office with the door open, a semi-private setting if you choose, it will be an informal, conversational session with general and open-ended questions that allow you to talk about yourself. The second interview will also take place in a semi-private setting if you choose, it will feature an Infinity Gauntlet and will be structured around your possible self dynamics. If you do not agree to be digitally recorded, you will not be interviewed for this study. Your identity will be held in strict confidence on all public records of this study.

### RISKS AND BENEFITS:

While participating in this study, you will encounter minimal risks. The first risk of participation in this study is no different from any other 3D Printing practice, there is a risk of burns or risk of injuries if you touch a hot surface.

The second risk of participation will include the potential inconvenience of scheduling the interview. The researcher will minimize these risks by scheduling at a time that is convenient for you, or while a 3D print is being produced. You reserve the right to not answer any question or forfeit the interview at any time if you feel uncomfortable. This research is being conducted by Lawrence Nightingale in his personal capacity, and he is solely responsible for risks and benefits that may result from this research.

The benefits of participating in the study include the opportunity to reflect upon, articulate, and discuss your experience as a cutting-edge community college 3D Printing practitioner. This includes the opportunity to design and print any publicly appropriate object of your choosing for free, field trips to a high-tech manufacturing site, a collaboration with George Mason University, and being featured as a technologist to members of the community.

### PRIVACY AND CONFIDENTIALITY:

Your confidentiality will be protected to the maximum extent allowable by law. Any directly identifying information, including your name, will be removed from data when responses are analyzed. All data will be secured on a password protected cellular phone, and password-protected computer in a secured office. The data will be accessible only to the researchers associated with this study and the Institutional Review Board. During analysis, pseudonyms (fake names) will be assigned to your information so that your identity is protected.

During dissemination, findings will be reported by theme (aggregating the data) or by pseudonym (assigning a fake name). The results of this study may be published or presented at professional meetings, but the identities of all research participants will remain confidential. Special care will be taken to mask markers of identity (e.g. international school, intended university, and biographical data). Every attempt will be made to keep your identity private; the researchers will assure that identifiable speech patterns, ways of talking, and turns of phrase that would make a participant identifiable will be redacted. All identifiable characteristics, references to identity, and distinguishing aspects contained in the data collected will be redacted, removed, or masked in order to protect the privacy of the participants.

All data will be stored for at least five years after the project closes. Five years after the conclusion of the study, the data (digital audio files, transcripts, my notes, documents related) will be destroyed.



### YOUR RIGHTS TO PARTICIPATE, SAY NO, OR WITHDRAW:

Your participation is completely voluntary. It is OK for you to say NO. Even if you say YES now, you are free to say NO later, and walk away or withdraw from the study – at any time. You may choose not to participate at all, or to answer some questions and not others. You may also change your mind at any time and withdraw as a participant from this study with no negative consequences. Your decision will not affect your relationship with the college, campus employment, or otherwise cause a loss of benefits to which you might otherwise be entitled.

### COSTS AND COMPENSATION FOR BEING IN THE STUDY:

You will receive free 3D Printing instruction and use free high-quality filament at no cost to you, there is no compensation for participating in this study.

### CONTACT INFORMATION FOR QUESTIONS AND CONCERNS:

If you have any questions later on, then the researchers should be able to answer them; please contact the researchers Dr. Chris R. Glass, 2309 Education Building, Old Dominion University, Norfolk, VA, [crglass@odu.edu](mailto:crglass@odu.edu), +1-757-683-4118.

If at any time you feel pressured to participate, or if you have any questions about your rights or this form, then you should call Dr. Laura Cheznan, Chair of the Human Subjects Review Committee for the Darden College of Education) at +1-757-683-7055, or the Old Dominion University Office of Research, at +1-757-683-3460.

By signing below, you are indicating your voluntary participation in this study and acknowledge that you may: 1) choose not to participate in the study; 2) refuse to answer certain questions; and 3) discontinue your participation at any time without any penalty or loss of benefits to which you are otherwise entitled. You are saying that you have read this form or have had it read to you, that you are satisfied that you understand this form, the research study, and its risks and benefits. The researchers should have answered any questions you may have had about the research. The researcher will give you a copy of this form for your records.

Your signature below indicates your voluntary agreement to participate in this study.

Signature \_\_\_\_\_ Date \_\_\_\_\_

Name (Printed) \_\_\_\_\_

In addition, your signature below means that you voluntarily agree to allow your responses to be digitally recorded.

Signature \_\_\_\_\_ Date \_\_\_\_\_

#### INVESTIGATOR'S STATEMENT

I certify that I have explained to this subject the nature and purpose of this research, including benefits, risks, costs, and any experimental procedures. I have described the rights and protections afforded to human subjects and have done nothing to pressure, coerce, or falsely entice this subject into participating. I am aware of my obligations under state and federal laws, and promise compliance. I have answered the subject's questions and have encouraged him/her to ask additional questions at any time during the course of this study. I have witnessed the above signature(s) on this consent form.

Signature \_\_\_\_\_ Date \_\_\_\_\_

Name (Printed) \_\_\_\_\_

### Appendix C

### 3D Printing Infinity Gauntlet



**Appendix C**

## Names of 3D Printers

Claudette Colvin

George Washington Carver

Wilma Rudolph

Eric Holder

Reece Taylor

Thurgood Marshall

Bass Reeves

Booker T. Washington

Mae Jemison

Harvey Milk

## Appendix D

### Outreach materials for 3D Printing and Robotics Club (3D PARC)

## Planned 3D Printer build: Piper 2

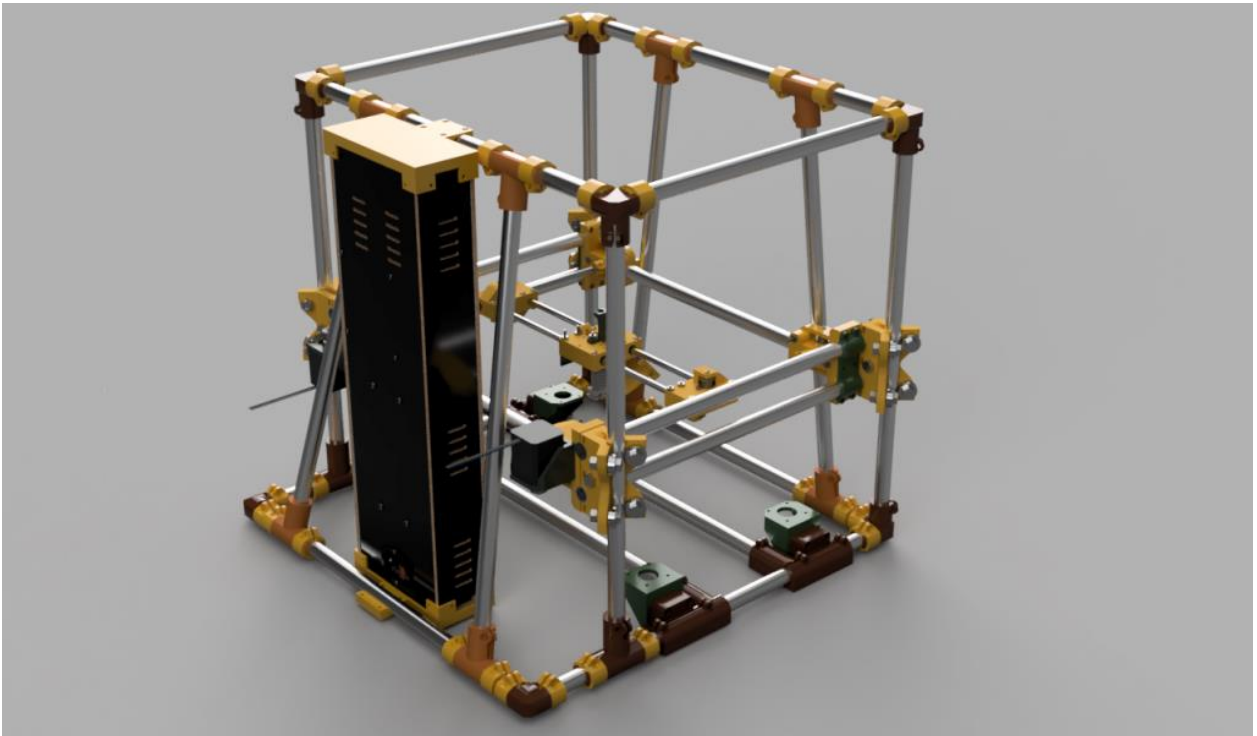

## On Campus Job Opportunity

# 3D Printing Technician

15-20 Hours

Do you like to be creative?

- Have you ever taught anyone how to make something?
- Are you a hard worker who is good at understanding directions?

**YES? Then go to the Financial Aid Office (WS) Room 229 to apply.**

For more info contact:

LNIGHTINGALE [REDACTED]@EDU





## Appendix E

### 3D Printing activities

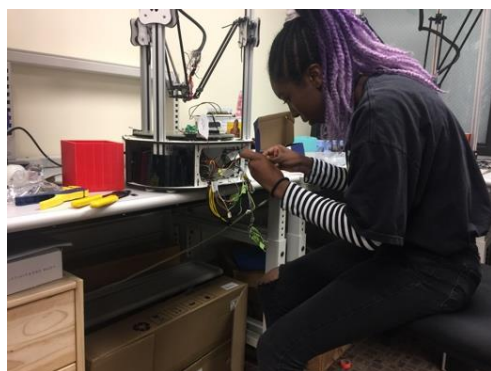
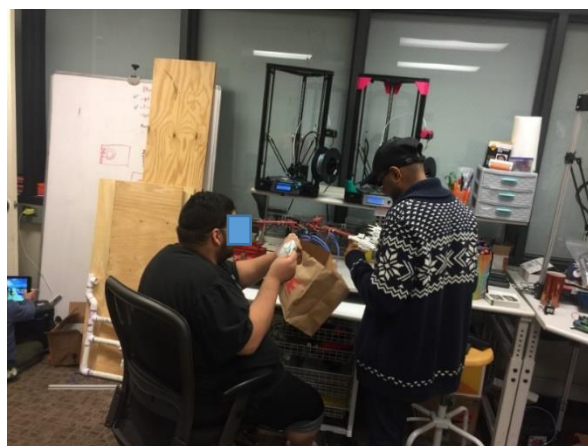
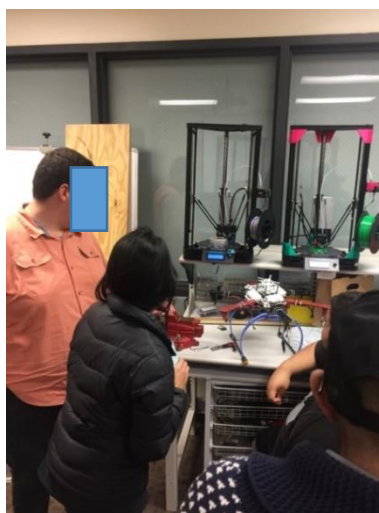



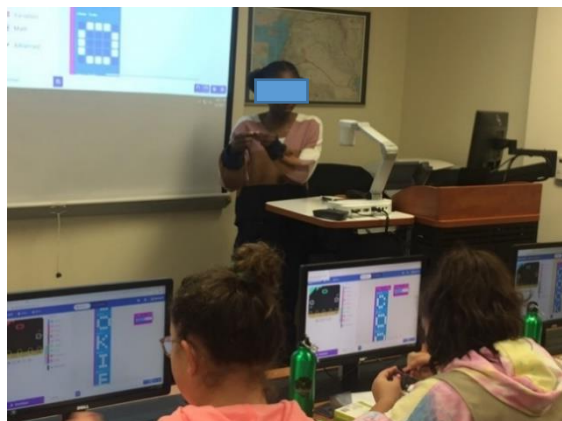



3D PARC Holiday Event  
SILENT AUCTION BID SHEET  
Bids are a commitment to pay in cash no exceptions  
Last Bid: 1:30 Payment Due 2:00 pm  
UR ORNAMENT

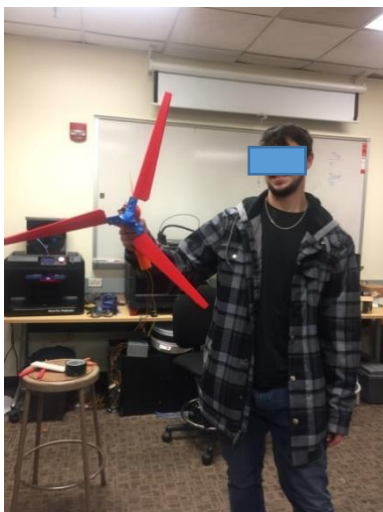

**Table 1***Participant Descriptions*

<b>Name</b>	<b>Age</b>	<b>Gender</b>	<b>Ethnicity</b>	<b>Major</b>	<b>3D PARC</b>	<b>Leadership</b>	<b>Class credit</b>	<b>Employee</b>
Maverick	22	M	Asian	Cyber Security A.S.	Yes	Yes	No	Yes
Goose	18	M	Hispanic African	Engineering A.S.	Yes	Yes	Yes	Yes
Pheonix	18	F	American	Psychology A.S.	Yes	No	No	Yes
Merlin	35	M	Asian	HVAC A.A.S.	No	No	Yes	No
Viper	20	M	Caucasian	Engineering A.S.	Yes	Yes	No	Yes
Slider	25	M	Caucasian	Design A.A.	Yes	No	No	Yes
Iceman	24	M	Caucasian	Engineering A.S.	Yes	No	Yes	No
Wolfman	19	M	Cucasian	Engineering A.S. Biomedical Engineering	Yes	No	No	No
Cougar	21	F	Hispanic	(NA)	No	No	Yes	No
Hollywood	22	M	Caucasian African	Engineering A.S.	No	No	Yes	No
Chipper	24	M	American	Business A.S.	No	No	Yes	No
Stinger	18	M	Hispanic	Engineering A.S.	Yes	Yes	No	No
Sundown	18	M	Hispanic	Engineering A.S.	No	No	No	Yes

*Note.* Participant pseudonym, age at the time of the study, ethnicity, current major, participation in 3D Printing and Robotics Club, leadership team status, use of the 3D Printing lab for course credit, and status as a 3D Printing technician or instructor.

**Table 2***Participant objects printed and events attended*

<b>Name</b>	<b>Objects printed</b>	<b>YFT</b>	<b>Reprap festival</b>	<b>Tech Festival</b>	<b>Fund raiser</b>	<b>Home practitioner</b>
Maverick	Guy Faulks mask	No	No	No	No	No
Goose	Card Holder	Yes	Yes	Yes	Yes	No
Phoenix	Mickey Mouse Ornaments	No	No	Yes	Yes	No
Merlin	HVAC Fan (wrench turner)	No	No	No	No	No
Viper	Sweeper bot, robot arm	Yes	Yes	Yes	Yes	No
Slider	Einstein bust (3 times)	Yes	Yes	No	Yes	Yes
Iceman	Solar system	No	No	No	No	No
Wolfman	Mountain bike brake mount	No	No	No	Yes	Yes
Cougar	Windmill project	No	No	No	No	No
Hollywood	Windmill project	No	No	No	No	No
Chipper	World Series mini bat	No	No	No	Yes	No
Stinger	Kirby, Elsa, Christmas Ornaments	Yes	Yes	Yes	Yes	Yes
Sundown	Hearts, family gifts	No	No	Yes	No	No

*Note.* Participant pseudonym, the theme of objects printed by participant, participation in The Youth For Tomorrow Event (outreach), attendance of The East Coast Reprap Festival (outreach), contributor to the Booker T. Washington County Youth and Technology Festival (outreach/peer education), donator of a 3D printed object to the 3D PARC fundraiser (competition/employment), and current 3D printer ownership status (outreach).

**Table 3***Participant snapshots and overarching quotes*

<b>Name</b>	<b>Major theme</b>	<b>Interview quote</b>
Maverick	Highlighted student, exemplary involvement on campus and off	I grew along with the technology, and it helped me because I was always able to learn more.
Goose	Building skills on a foundation of Math knowledge	I think the lab is, it's almost like a playground, not as in playful, but there are a lot of different things that happen.
Phoenix	Community College grants the Freedom to excel	This like job it opened a lot of doors for me. I knew about 3D Printing, but it wasn't to this extent. Plus there are just so many career paths out there, (I'm) like thinking well maybe I should like go into this.
Merlin	Highly skilled participant, dedicated to graduation and next chapter of life.	I would never throw my community college education away, too valuable.
Viper	Roboticist that uses 3D Printing as a tool	I have had the goal in my life to try and be a known person, leave a legacy, have my name in the history books.
Slider	A futurist who uses 3D Printing a tool, peer educator	The thing is I want to make sure that I am part of a generation. I still inspire people to keep swimming up that river, so they're able to inspire the next generation after that and so on.
Iceman	Higher education restart in a better institution	When I came back, I kind of thought of Nova as a, you know, a fresh start for me.
Wolfman	"Nerding out" opens unexpected doors	I can design and make something, and there's been things that I've put together on a computer and thought that's fun. Nothing's going to happen, but 3D Printing feels like I'm a lot closer to making all that happen.
Cougar	Newfound confidence, developing lab science professional	So why can't, you know, why shouldn't I be able to do this? You know, there's really no limit on that anymore.
Hollywood	3D Printing is fun, something that fits academic curiosity	For me to complete this project, it's able for me to look ahead to see what my future opportunities could be like.
Chipper	Accelerated learning: conception to sales in less than two weeks	It's definitely opened my eyes to like a different market, and process of assembly that might be introduced into the world, you know, introducing a new assembly line.
Stinger	The engineering curriculum is one large PBL project	My main objective is to get the most out of college using the resources here now instead of waiting to use them. I think that'll propel me forward faster and being able to advance my skills early on instead of having them wait a few months.

Sundown	A high achiever who discovers new skills	When we're dealing with that printer, and you asked me to like do that thing, and I was just struggling with this so hard. Um, but overall, I do find a lot of enjoyment in it despite having its challenges.
---------	--	---

---

*Note.* Participant pseudonym, the major theme presented across interviews, and quote that illustrates the most notable possible selves dynamics.

Figure 1. Possible Self Progression with 3D Printing

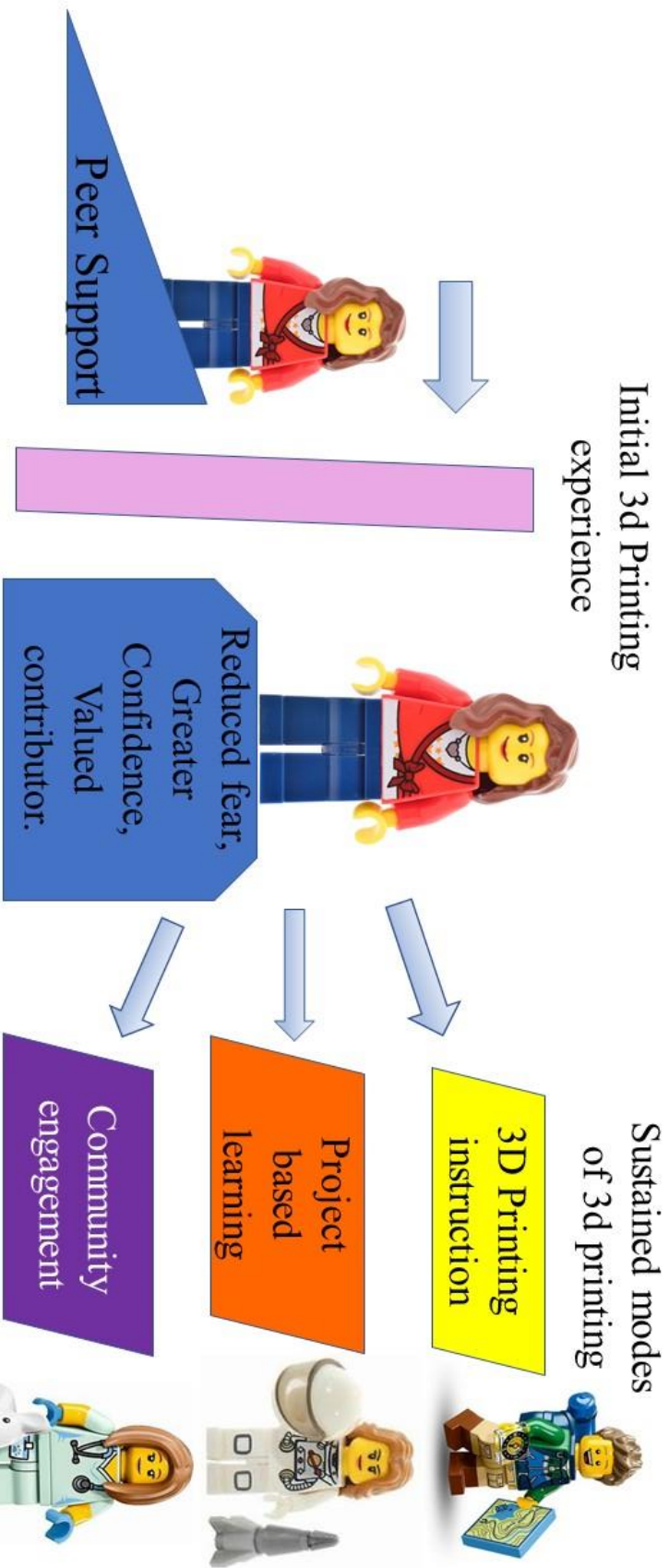

*Note.* Representation of the possible self dynamics of the student participants. Students enter the lab. Through a peer supported process they gain confidence and continue their work with the lab, the continued work results in reported changes in student future self ideation.

Figure 2. stl files of 3D Printed objects

Figure 2.1. Plate one of the robotic arm project. The project remained incomplete after Viper had manufactured approximately 60 percent of the parts. The parts pictured are the structural parts of the articulating arm.

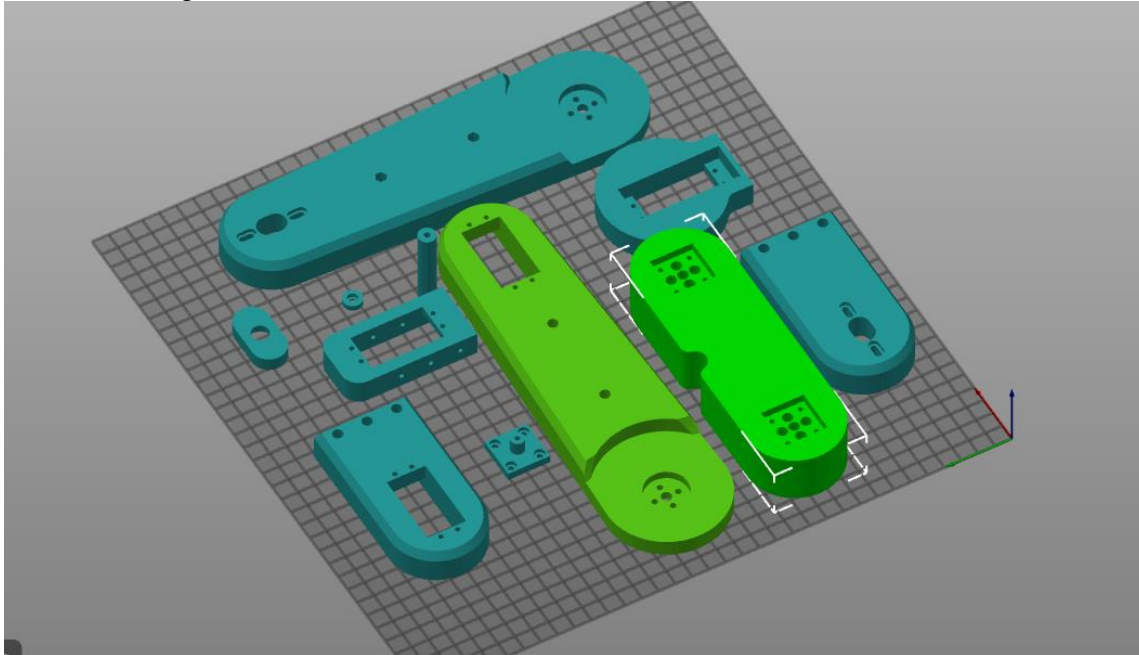

Figure 2.2. Plate two of the robotic arm project. The parts pictured here are the arm base. Viper was obligated to print the large circular base components separately due to their size.

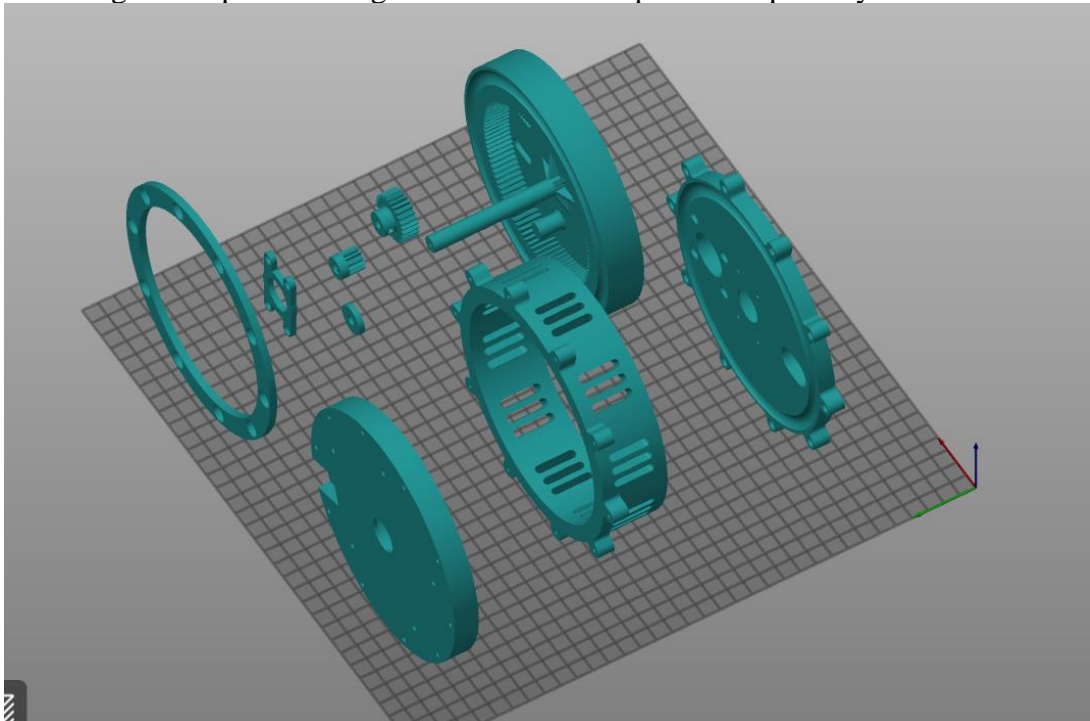



Figure 2.3. Plate 3 of the robotic arm project. The parts pictured here combine to be the arm gripper.

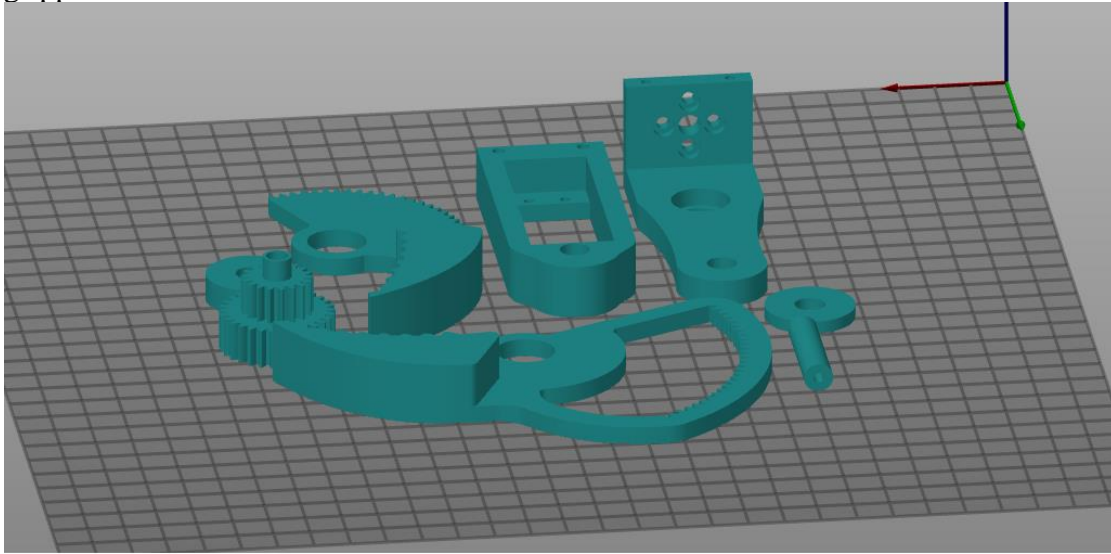

Figure 2.4. .stl of the Voronoi heart that Sundown attempted three times, once successfully. The profile of the printer was not specific to the machine that Sundown was using on the first two iterations. On the third iteration, an accurate printer profile was utilized, allowing for a completed model to be produced.

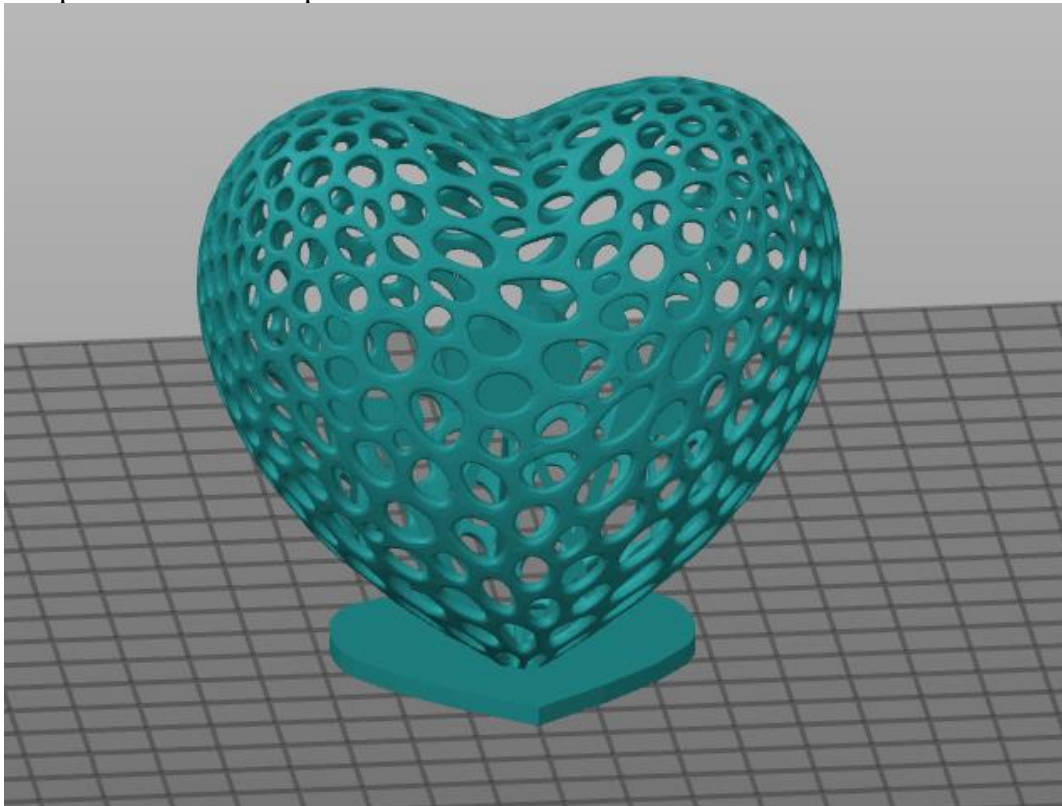

Figure 2.5. .stl of the Pac Man ghost printed by the researcher and Phoenix on her first day of work. The model was attempted twice. After the first incomplete print, the proper z adjustments were made, and the model printed in less than 20 minutes.

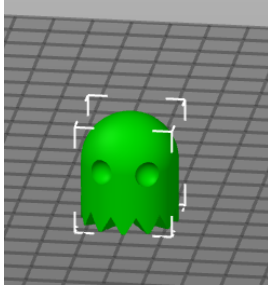

Figure 2.6. .stl of the Pokeball produced by Phoenix.

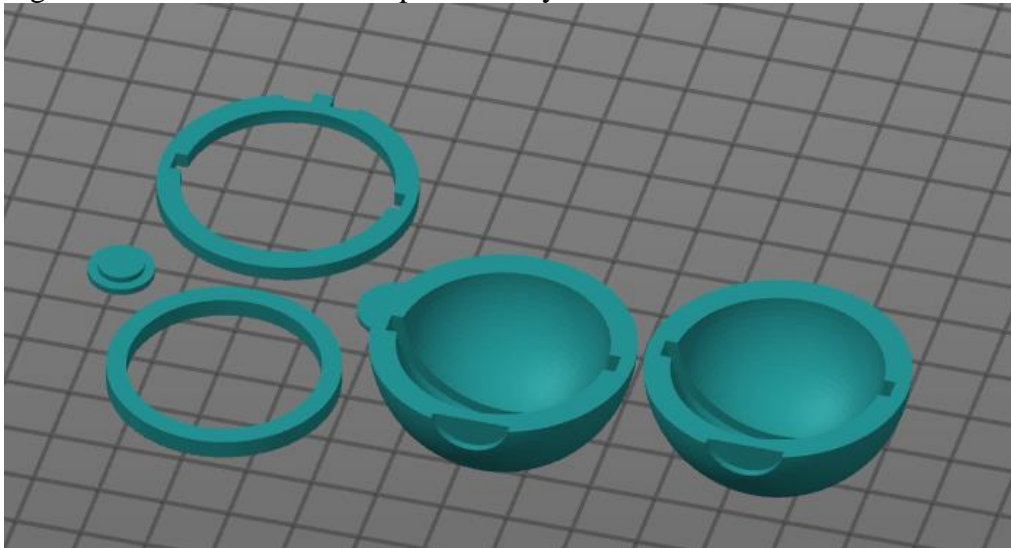

Figure 2.7. .stl of the Mickey Mouse snowflake that was produced by Phoenix for the first iteration of the 3D PARC fundraiser. The Mickey Mouse snowflakes commanded a respectable price during the silent auction.

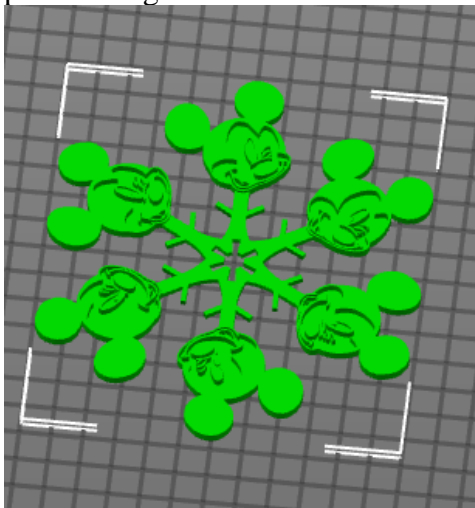

Figure 2.8 .stl of the Mickey Mouse hands Christmas ornament produced by Phoenix for the second fundraiser. The design was compact, flat, and easily repeated during a work shift for Phoenix. Phoenix used the file to produce the most items for the silent auction, winning her a \$25.00 gift certificate to Chic-Fil-et.

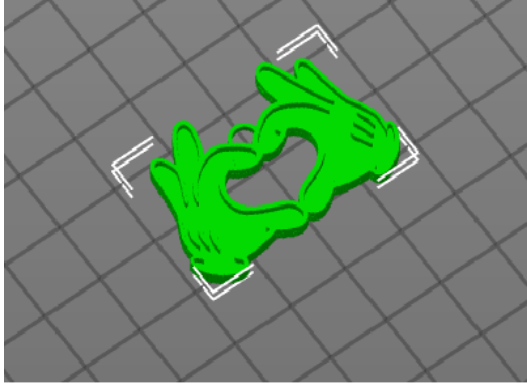

Figure 2.9. .stl of Merlin's originally designed HVAC circulation fan. The model of the fan was designed and produced in less than an hour.

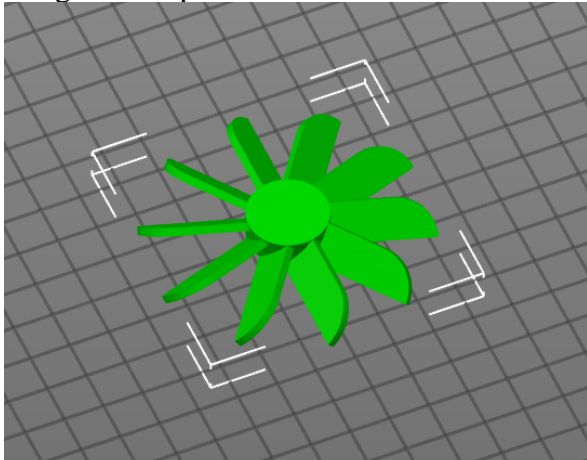

Figure 2.10. .stl of Albert Einstein that was attempted three times by Slider for the first iteration of the silent auction. The hair on top of Einstein's head would not print without incident.

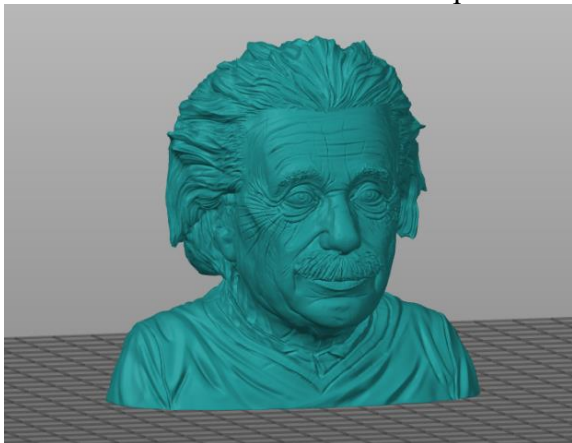

Figure 2.11. .stl of the top hat that was added to the Einstein bust by Slider to get the object ready for auction. The two completed objects consumed approximately 2 kilos of filament through three iterations of Einstein and one iteration of the top hat. The completed model sold for less than the Mickey Mouse ornaments but consumed close to 100 times more material.

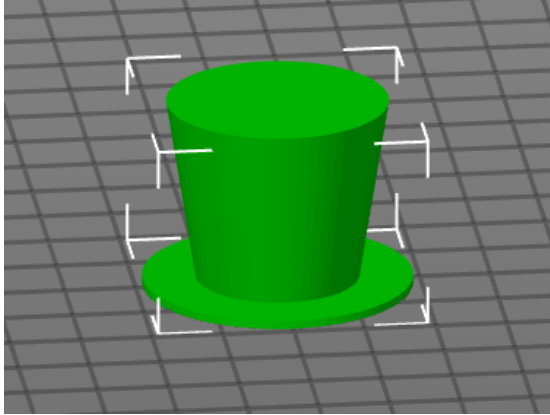

Figure 2.12. .stl of the custom doorstop designed by Slider as a proof of concept for Chipper. The doorstop is currently in use in the 3D Printing lab at CCBTWC.

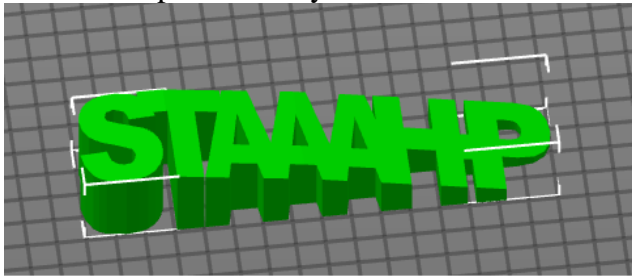

Figure 2.13. .stl of the world record attempt Flexi T-Rex attempted by Slider. Slider commissioned the lab's largest printer to try to produce the model. The model remained incomplete through the duration of the study.

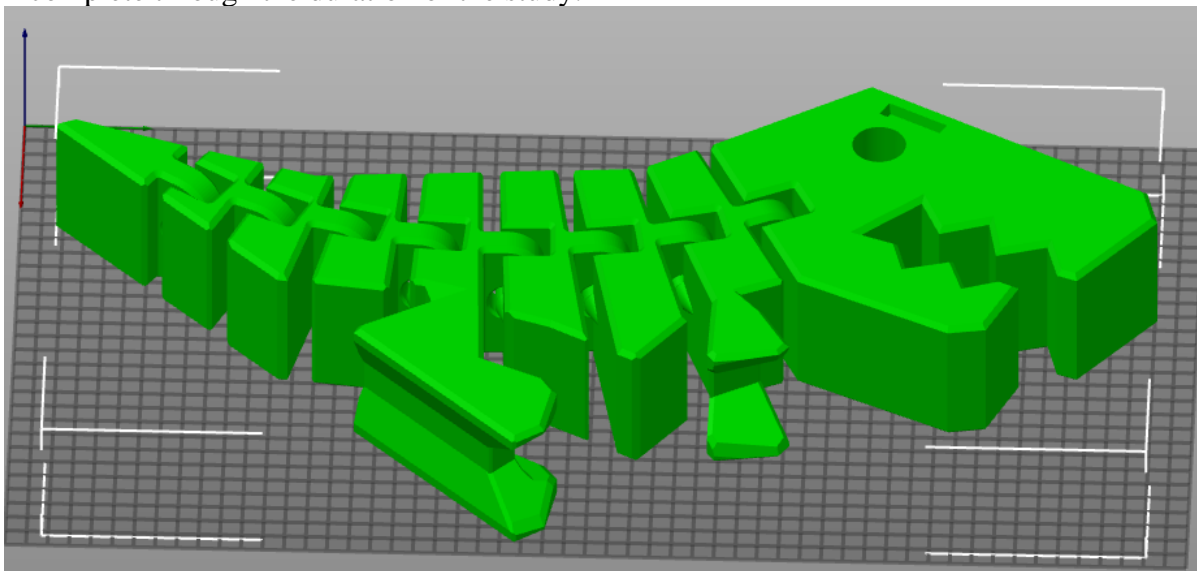

Figure 2.14. .stl of the simple rocket produced by Slider. The model was produced in hard PLA plastic, a typical material. The rocket was also produced in TPU (Thermoplastic Polyurethane) a flexible material that is much more challenging to work with. The machine that jester used to produce the model in TPU is a custom modified version of the delta 3d printers in the CCTBWC lab.

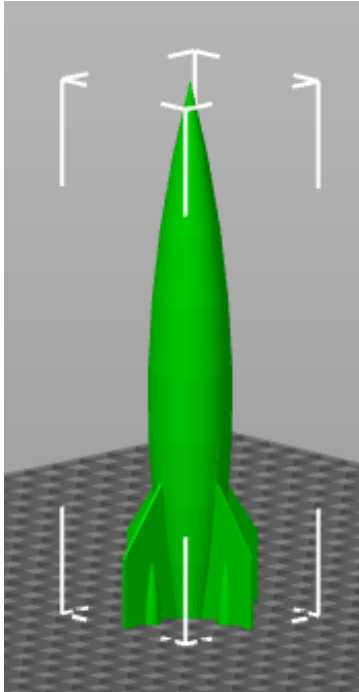

Figure 2.15. .stl of the components of the miniature robot attempted by Maverick and Fanboy. The attempt to make a working robot proved to be elusive. Maverick asserts that the endeavor allowed him to learn despite the incomplete status.

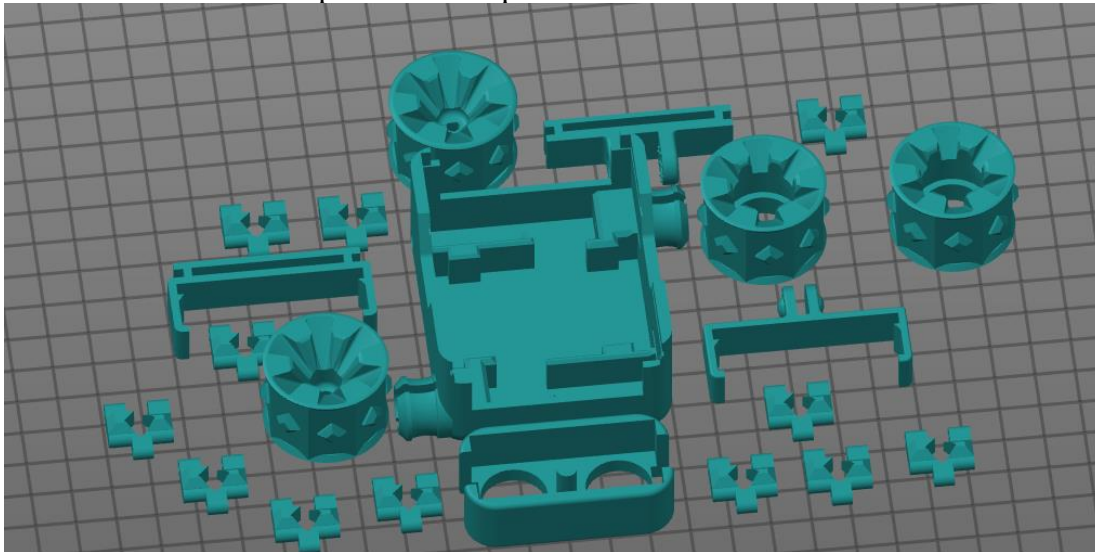

Figure 2.16. .stl of a 400 mm tall vase that was produced for the silent auction by the researcher. The vase did not command a price that was anticipated, giving the 3D PARC group the idea that the strategies needed to be revisited in order to produce a successful fundraiser.

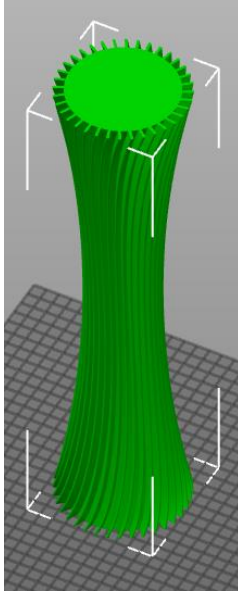

Figure 2.17. .stl of a high-resolution representation of the planet Saturn produced by Iceman. The object is seen as a challenging object to produce due to its size and detail. The Saturn .stl was produced, and Iceman resolved to design a complete solar system as well as a spinning, illuminated mount for the completed Saturn model.

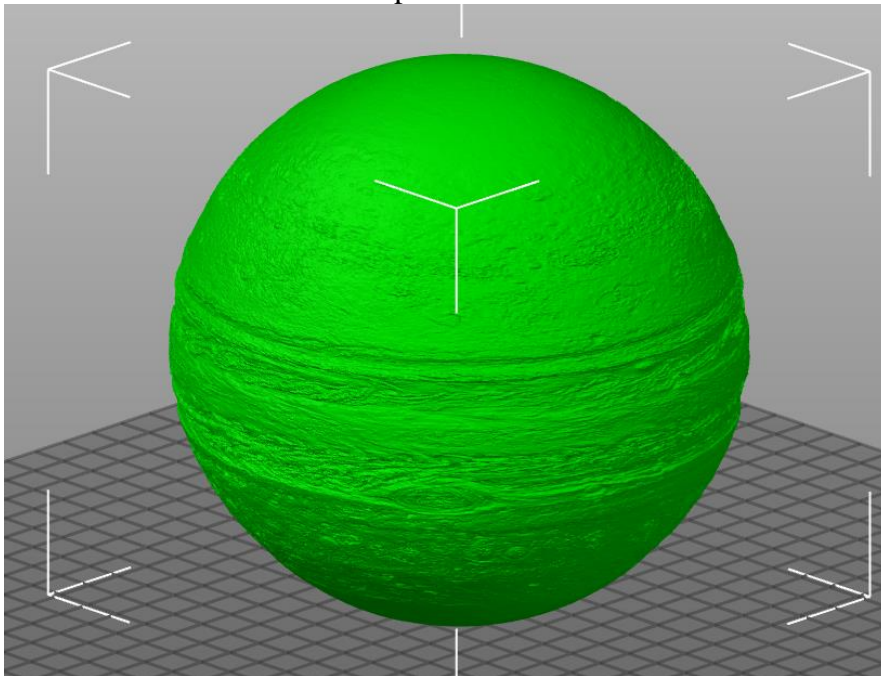

Figure 2.18 .stl of the windmill fan blades that Cougar and Hollywood constructed for a class project. The green at the bottom of the blade is support material that needs to be trimmed away.

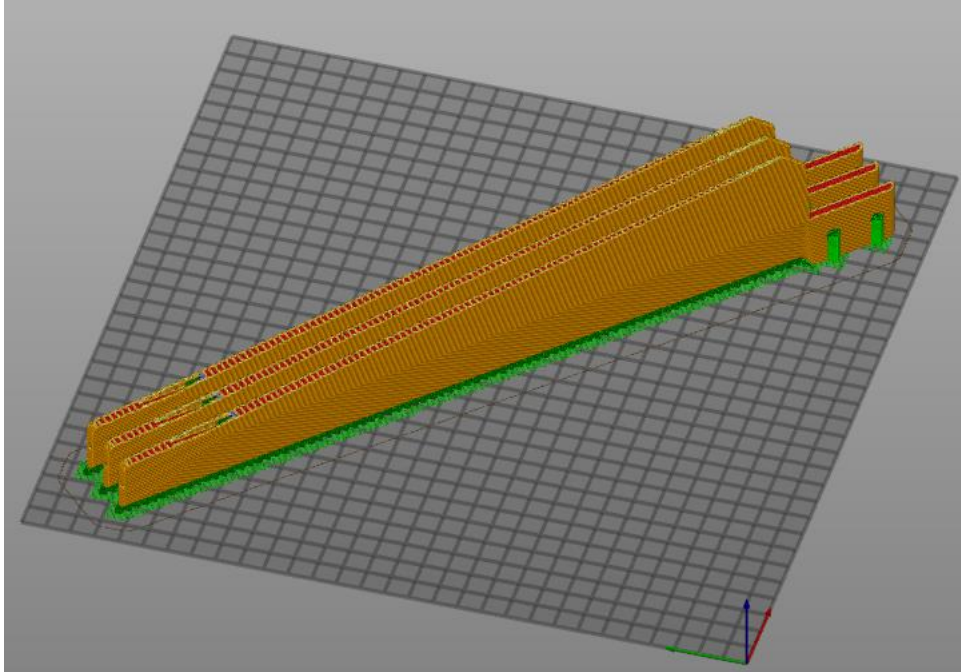

Figure 2.19. .stl of the windmill hub components that Cougar and Hollywood constructed for a class project. The green at the bottom and sides of the models need to be trimmed in order for the windmill to work properly.

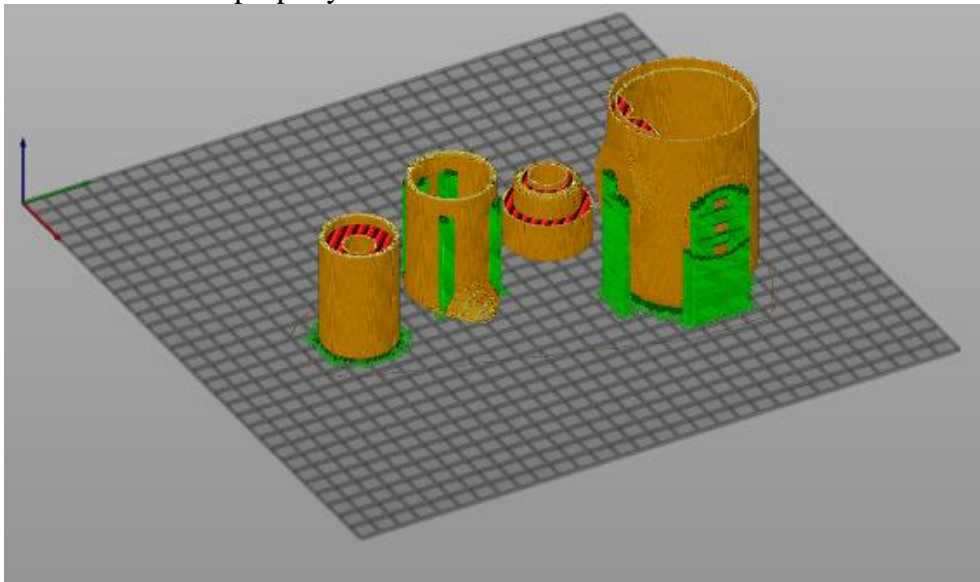

Figure 2.20 .stl of more windmill hub components that Cougar and Hollywood constructed for a class project.

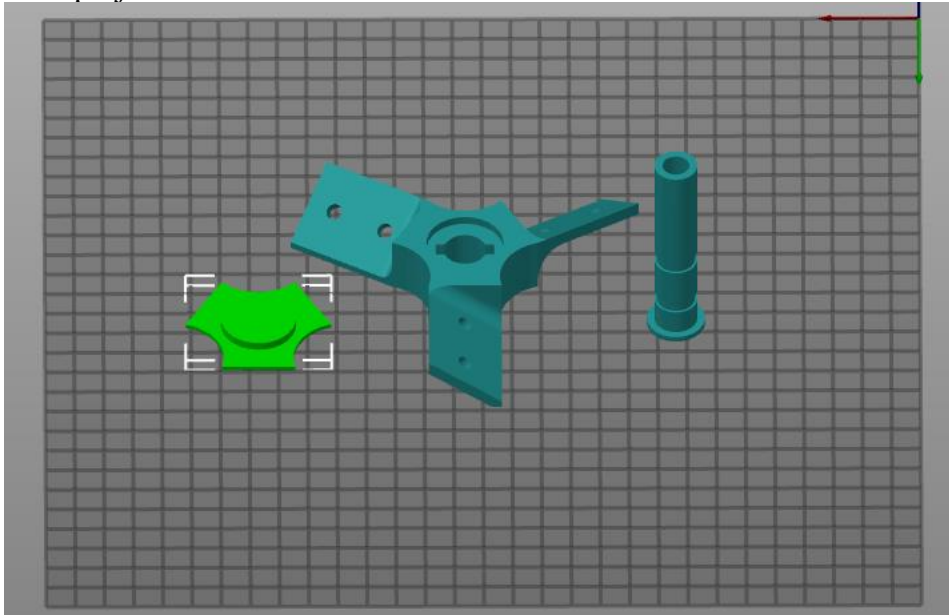

Figure 2.21. .stl of the windmill structural components that Cougar and Hollywood constructed for a class project.

