

University of Montana

ScholarWorks at University of Montana

Graduate Student Theses, Dissertations, &
Professional Papers

Graduate School

2020

Influence of Livestock and Electrified Fences on Livestock Depredation and Habitat Selection by Grizzly Bears in the Mission Valley, Montana

Kari Lynn Eneas

Confederated Salish Kootenai Tribes Wildlife Management Program

Follow this and additional works at: <https://scholarworks.umt.edu/etd>



Part of the [Other Animal Sciences Commons](#), and the [Terrestrial and Aquatic Ecology Commons](#)

Let us know how access to this document benefits you.

Recommended Citation

Eneas, Kari Lynn, "Influence of Livestock and Electrified Fences on Livestock Depredation and Habitat Selection by Grizzly Bears in the Mission Valley, Montana" (2020). *Graduate Student Theses, Dissertations, & Professional Papers*. 11551.

<https://scholarworks.umt.edu/etd/11551>

This Thesis is brought to you for free and open access by the Graduate School at ScholarWorks at University of Montana. It has been accepted for inclusion in Graduate Student Theses, Dissertations, & Professional Papers by an authorized administrator of ScholarWorks at University of Montana. For more information, please contact scholarworks@mso.umt.edu.

INFLUENCE OF LIVESTOCK AND ELECTRIFIED FENCES ON LIVESTOCK
DEPREDATION AND HABITAT SELECTION BY GRIZZLY BEARS IN THE MISSION
VALLEY, MONTANA

By

KARI LYNN ENEAS

B.S., University of Montana, Missoula, Montana, 2013

Thesis

presented in partial fulfillment of the requirements
for the degree of

Master of Science
in Wildlife Biology

The University of Montana
Missoula, MT

May 2020

Approved by:

Scott Whittenburg, Dean of The Graduate School
Graduate School

Michael Mitchell, Co-Chair
Wildlife Biology Program, Montana Cooperative Wildlife Research Unit

Chad Bishop, Co-Chair
Wildlife Biology Program

Erick Greene
Wildlife Biology Program, Division of Biological Sciences

Jennifer Fortin-Noreus
United States Fish and Wildlife Service, Grizzly Bear Recovery Program

Dale Becker
Confederated Salish Kootenai Tribes, Wildlife Management Program

Influence of Livestock and Electrified Fences on Livestock Depredation and Habitat Selection by Grizzly Bears in the Mission Valley, Montana

Co-Chairperson: Michael Mitchell

Co-Chairperson: Chad Bishop

ABSTRACT

Balancing protection between livestock and carnivores has been a long-standing challenge in conservation. When encounters between carnivores and livestock or humans result in conflict or livestock depredation, the safety of both wildlife and humans are at risk. Reducing livestock depredation by grizzly bears (*Ursus arctos horribilis*) will be important as populations continue to recover and expand beyond public lands in the Northern Continental Divide Ecosystem.

We used GPS locations from 8 female grizzly bears spanning 5 years in the Mission Valley, Montana, to evaluate the effect of livestock on habitat selection of grizzly bears. The Mission Valley is located on the Flathead Indian Reservation, where grizzly bears have been historically revered; however, modern cultural diversity complicates current management. We found a positive relationship in habitat selection for streams and wetlands by grizzly bears. We found that bears did not select for livestock, and that livestock did not have an effect on selection of streams or densities of homes or roads.

Whereas electric fencing has been frequently used to protect bee apiaries from depredation by bears in North America, they have only recently been used to protect crops and livestock against grizzly bears. Maps based on our results can be used to identify how and where electric fencing efforts could be focused to reduce livestock depredation. We identified 20 sites with small livestock that had electrified fencing and 72 sites that were unfenced in 2018. We monitored 12 electric fences surrounding small livestock and recorded the presence and behaviors of grizzly bears in the Mission Valley during 2018 – 2019.

No depredations occurred when livestock were inside a properly functioning electric fence, and 7 livestock depredations occurred at sites without electrified fencing. This suggested that electric fences were effective at reducing livestock depredations by grizzly bears. Though different attitudes about grizzly bears exist on the Flathead Indian Reservation, proactive and non-lethal actions can be implemented by residents to minimize future conflicts between livestock and grizzly bears. Securing small livestock, agricultural crops and livestock feed inside of an electric fence can prevent conflict in the Mission Valley.

ACKNOWLEDGMENTS

This research is the result of many collaborations between a number of entities and individuals who have contributed to its success. Funding for this project was provided by the Confederated Salish Kootenai Tribes (CSKT) Wildlife Management Program and Higher Education, University of Montana, the W.A. Franke College of Forestry and Conservation, Alfred P. Sloan Foundation and Vital Grounds Foundation.

I would like to thank personnel from the Confederated Salish Kootenai Tribes Wildlife Management Program for providing data, equipment, and staff efforts in the field to this study on the Flathead Indian Reservation. A special thanks to S. Courville and S. Clairmont who taught me about grizzly bears, mentored me in the field, and devoted time and discussions about grizzly bear conflict and management in the Mission Valley. A special thanks also to D. Becker for the support and encouragement in pursuing this Master of Science degree. Thank you also to Montana Fish Wildlife and Parks who have contributed to the collection of data used in this study, and to the U.S. Fish and Wildlife Service for consultations about grizzly biology and conflict on the landscape.

I would also like to thank Swan Valley Connections for collar retrieval in the Mission Mountains, as well as Defenders of Wildlife and People and Carnivores for promoting coexistence with grizzly bears through outreach and providing resources for electric fences to Mission Valley Residents.

Instruction, guidance and encouragement from all of my UM professors, mentors and peers were greatly appreciated. Special thanks to M. Mitchell for pushing me to ‘think like a bear’ and for teaching me how to break down a management question into strong ecological research questions. The professional and analytical skills taught to me throughout the course of this

research has proven invaluable to its success and will continue to serve me throughout my career in wildlife management. I have gained confidence in my understanding of wildlife research and statistical analysis due to the incredible knowledge and enthusiasm of the collective Wildlife Biology Program.

I also extend much gratitude to the private landowners who participated in this project. For allowing me to install electric fences and monitor research cameras at their personal residences for two entire field seasons. For sharing their appreciation of the grizzly bears and other wildlife supported by the Flathead Indian Reservation, and most importantly, for honoring the grizzly bear by exemplifying good stewardship and coexistence in the Mission Valley.

A special thanks to Tribal Council members of the Confederated Salish Kootenai Tribes as well, for their support of this research and their determination to coexist with the grizzly bears on the Flathead Indian Reservation.

A NOTE ON AUTHORSHIP

Henceforth in this thesis, when I use the term “we” I am recognizing all of the collaborators who dedicated valuable time, guidance, mentorship, manuscript edits, and technical field assistance to this project in order to make it a success.

TABLE OF CONTENTS

Abstract	ii
Acknowledgments	iii
A note on authorship	iv
List of Tables	vi
List of Figures	vii
Chapter	
I. History and Introduction of Grizzly Bear Conflict	1
Literature Cited	5
II. Influence of Livestock on Habitat Selection of Grizzly Bears	9
Abstract	10
Introduction	10
Methods	15
Results	18
Discussion	18
Literature Cited	22
III. Using Electric Fences to Prevent Livestock Depredation by Grizzly Bears	36
Abstract	37
Introduction	37
Methods	40
Results	42
Discussion	44
Literature Cited	48

LIST OF TABLES

Table	Page
1. Descriptions and hypothesis predictions for all environmental features included in resource selection functions modeling habitat selection of grizzly bears in the Mission Valley, MT between the years 2015 – 2019.....	31
2. Results of individual and averaged resource selection function sample means and variances of all covariates from 8 female grizzly bears in the Mission Valley, MT during 2015 – 2019.....	32
3. Probabilities of livestock depredation by grizzly bears at sites in the Mission Valley, MT with and without electrified fencing during the years 2018 – 2019.	53
4. Results of grizzly bear observations at small livestock sites protected with electrified fencing during the summers of 2018 and 2019 in the Mission Valley, MT.....	54

LIST OF FIGURES

Figure	Page
1. The Flathead Indian Reservation and study area (shaded in green) used for evaluating habitat selection of grizzly bears in the Mission Valley, MT.....	33
2. Plot of sample means and 95% confidence intervals from individual bear resource selection functions for female grizzly bears during 2015 – 2019 in the Mission Valley, Montana.....	34
3. Resource selection Function (RSF) predictions of habitat selected by female grizzly bears in the study area during the years 2015 – 2019. Color gradient based probabilities of bear use from model covariates. A) Locations of 36 confirmed small livestock depredations by grizzly bears during 2015 – 2019. B) Distribution of 92 small livestock sites in the Mission Valley, MT. C) Streams in the Mission Valley, MT.....	35
4. Study area in Mission Valley, MT (shaded in green) displaying locations of 12 sites observed for grizzly bear presence during the summers of 2018 – 2019.....	55
5. Two fence designs used in the study. A) Permanent design was modeled after Fish Wildlife and Parks specifications for grizzly bear deterrence (Annis 2017). B) Temporary fence design with Kencove electrified netting (Blairsville, PA).....	56
6. Positioning of cameras used for monitoring grizzly bear behavior at small livestock sites protected with electrified fencing. Cameras were placed on opposite ends of the fences and positioned between 25 – 35 feet away from the fence to cover a wide viewing radius.....	57
7. Maps showing locations of 8 female grizzly bears, livestock and houses in the Mission Valley during the years 2015 – 2018. Bear locations were taken between March 20 – October 31 of each year. Bears used areas near residential homes frequently, yet none of these collared bears were involved in conflict or livestock depredation at these home sites during this study.....	58

CHAPTER I: HISTORY AND INTRODUCTION OF GRIZZLY BEAR CONFLICT

Conflict can broadly be defined as a competitive action resulting from incompatible or opposing needs (Conflict 2003). When encounters between carnivores and livestock or humans result in conflict, the safety of both wildlife and humans are at risk (Halfpenny et al. 1991; Thouless and Sakwa 1995; Woodroffe 2000; Treves et al. 2002; Naughton-Treves et al. 2003). Human-wildlife conflict occurs when humans and wildlife compete for space and resources and results in negative impacts on people, animals, resources or habitats. These impacts can include habitat loss and fragmentation, crop raiding and agricultural depredation.

A long history of conflict exists between humans and grizzly bears (*Ursus arctos horribilis*; Mattson and Merrill 2002; Wilson et al. 2006; Northrup et al. 2012). Grizzly bears crossed over to North America about 60,000 years ago over the Beringia Land Bridge and expanded down into the Rocky Mountains about 26,000 years ago. They are a highly adaptable species and can survive in habitats like the Gobi Desert of Mongolia, feeding primarily on roots, plants and small mammals. Grizzly bears can also thrive in areas where their diets consist of salmon and other protein rich foods, reaching sizes up to 2 or 3 times bears in other environments. Grizzly bears can also adapt to us, as our actions can food condition bears and influence their spatial and temporal behaviors.

Following region-wide population declines, primarily due to habitat loss and conflicts between humans and grizzly bears, the grizzly bear was listed as threatened under the Endangered Species Act in 1975. With distribution reduced to less than 2% of historical range in the lower-48 States, recovery areas were established where grizzly bears still persisted or had in the recent past (Figure 1, USFWS 1993). These areas were mostly roadless and undisturbed habitats in protected public lands such as Yellowstone National Park, Glacier National park, and

designated Wilderness areas (USFWS 1993). Recovery efforts include reducing the potential for encounters between humans and grizzly bears that result in bear mortality (USFWS 1993).

Grizzly bear populations in the Northern Continental Divide Ecosystem (NCDE) recovery zone have increased in numbers and range (Costello et al. 2016; Peck et al. 2017) to inhabit over 63,800 km² (Costello and Roberts 2019). Early population studies estimated about 300 grizzly bears in this ecosystem at the time of listing (Kendall et al. 2008) and recent estimations put the population in the NCDE over 1,000 bears. (Costello et al. 2016; Peck et al. 2017). As populations of grizzly bears recover and expand their range (Kendall et al. 2009; Peck et al. 2017), bears travel farther from protected public places on to private and agricultural lands (Morehouse and Boyce 2017). This expansion increases contact between humans and bears, and this contact has potential to become conflict. Conflicts between humans and grizzly bears can include livestock depredation, close proximity to humans, property damage, and garbage raiding (Riley et al. 1994). Whereas important food resources for grizzly bears in the Mission Valley are cow parsnip (*Heracleum lanatum*), sedges, serviceberry (*Amelanchier*), chokecherry (*Prunus virginiana*), insects and apples (Mace and Jonkel 1986), animal matter is higher in energy and more digestible than sedges and berries. These sources may be sought after to increase body mass for winter hibernation (Schwartz et al. 2003). Whereas grizzly bears don't distinguish between wild and domestic animal protein, the resurgence of raising small livestock (chickens, goats, pigs, llamas) next to homes in both urban and rural areas have created a landscape ripe for conflicts in the NCDE.

Managing conflict is costly, as methods are time-consuming and complex (Linnel et al. 1997; Karanth and Madhusudan 2002; Naughton-Treves et al. 2003; Schivik et al. 2003). Once grizzly bears learn to depredate livestock, management actions can include relocation, which may

happen more than once because bears often return to the same site or depredate livestock where released (Thier and Sizemore 1981; Harting et al. 1987; Riley et al. 2008); 56% of relocated grizzly bears return to further agricultural depredation (Riley et al. 2008). When a grizzly bear is repeatedly managed for conflict or depredation or shows aggressive behavior toward humans, management may include lethal actions. Managers need to be able to implement effective non-lethal management tools to prevent conflict.

Balancing protection between small livestock and grizzly bears has been a challenge, and finding effective methods to reduce levels of depredation by bears might improve local attitudes towards grizzly bears and their conservation. The Mission Valley in western Montana was chosen for this study because of the recurring small livestock depredations and the unique challenges conflict poses to the culture and traditions of the Confederated Salish Kootenai Tribal people. Small livestock was chosen over large livestock (such as cows and horses) because of the lower costs associated with putting small livestock into protected enclosures or paddocks during the night. This provides opportunities for mitigation strategies like electric fencing to exclude bears and prevent depredation.

The Flathead Indian Reservation is part of the Demographic Monitoring Area (where population size and mortality limits are monitored) within the NCDE (Service 1993; NCDE Subcommittee 2019; Costello et al. 2019). This population of bears are positioned on the corridors, or pathways, between the NCDE and other recovery zones, like the Bitterroot and Greater Yellowstone Ecosystems. This becomes important when thinking about recolonization and gene flow between recovery populations (Figure 1). The people of the Confederated Salish and Kootenai Tribes (CSKT) have traditionally viewed their land as belonging to the grizzly bear first and have coexisted with grizzly bears since time immemorial. Perspectives and tolerances

toward grizzly bears and bear management have changed over time on the Flathead Indian Reservation and can make mitigating conflicts difficult.

To understand whether, and how, the presence of livestock influenced habitat selection by grizzly bears, this paper predicts habitat use in the Mission Valley, MT in Chapter II of this Thesis. The application and measure of effectiveness of electrified fencing, which is an important conflict mitigation tool, is tested in Chapter III. Both chapters are written in the format of the Journal of Wildlife Management where they will be submitted for publication.

LITERATURE CITED

- Conflict. 2003. Merriam-Webster's Dictionary. 11th ed. Springfield, MA.
- Costello, C.M.; R.D. Mace, L. Roberts. 2016. Grizzly Bear Demographics in the Northern Continental Divide Ecosystem, Montana: Research Results (2004-2014) and Suggested Techniques for Management of Mortality. Helena, MT.
- Costello, C. M., and L. L. Roberts. 2019. Northern Continental Divide Ecosystem Grizzly Bear Monitoring Team Annual Report, 2018. Kalispell, MT 59901.
- Halfpenny, J. C., M. R. Sanders, and K. A. McGrath. 1991. Human-Lion Interactions in Boulder County, Colorado: Past, Present and Future. Pages 10–16 in Mountain lion-human interaction symposium and workshop. Colorado Division of Wildlife, Denver.
- Harting, A. L., M. N. LeFrاند, and I. G. B. C. (U.S.). 1987. Grizzly Bear Compendium. Natural Wildlife Federation, University of Michigan.
- Karanth, K. U., and M. D. Madhusudan. 2002. Mitigating Human-Wildlife Conflicts in Southern Asia. Island Press, Covelo, California.
- Kendall, K. C., J. B. Stetz, J. Boulanger, A. C. Macleod, D. Paetkau, and G. C. White. 2009. Demography and Genetic Structure of a Recovering Brown Bear population. *Journal of Wildlife Management* 73:3–17.
- Linnel, J. D. C., R. Aanes, J. E. Swenson, J. Odden, and S. M. E. 1997. Translocation of Carnivores as a Method for Managing Problem Animals: a Review. *Biodiversity and Conservation* 6:1245–1257.

- Mace, R. D., and C. J. Jonkel. 1986. Local Food Habits of the Grizzly Bear in Montana. *International Conference on Bear Research and Management* 6:105–110.
- Mattson, D. J., and T. Merrill. 2002. Extirpations of Grizzly Bears in the Contiguous United States. *Conservation Biology* 16:1123–1136.
- Morehouse, A. T., and M. S. Boyce. 2017. Troublemaking Carnivores: Conflicts with Humans in a Diverse Assemblage of Large Carnivores. *Ecology and Society* 22.
- Naughton-Treves, L., R. Grossberg, and A. Treves. 2003. Paying for Tolerance: Rural Citizens; Attitudes toward Wolf Depredation and Compensation. *Conservation Biology* 17:1500–1511.
- NCDE Subcommittee. 2019. Conservation Strategy for the Grizzly Bear in the Northern Continental Divide Ecosystem.
- Northrup, J. M., G. B. Stenhouse, and M. S. Boyce. 2012. Agricultural Lands as Ecological Traps for Grizzly Bears. *Animal Conservation* 15:369–377.
- Peck, C. P., F. T. VanManen, C. M. Costello, M. A. Haroldson, L. A. Landenburger, L. L. Roberts, D. D. Bjornlie, and R. D. Mace. 2017. Potential Paths for Male-Mediated Gene flow to and from an Isolated Grizzly Bear Population. *Ecosphere* 8.
- Riley S. J., K. Aune, R. D. Mace, M. J. Madel. 1994. Translocation of Nuisance Grizzly Bears in Northwestern Montana. *International Conference of Bear Research and Management* 9(1):567-573.
- Riley, S. J., K. Aune, R. D. Mace, and M. J. Madel. 2008. Bears in Northwestern Montana.

Management 9:567–573.

Schivik, J. A., A. Treves, and P. Callahan. 2003. Nonlethal Techniques for Managing Predation: Primary and Secondary Repellents. *Conservation Biology* 17:1531–1537.

Schwartz, C. C., S. D. Miller, and M. A. Haroldson. 2003. Grizzly Bear. Pages 556–586 in G. A. Feldhamer, B. C. . Thompson, and J. A. Chapman, editors. *Wild Mammals of North America: Biology, Management, and Conservation*. Second edi. Johns Hopkins University Press, Baltimore, Maryland.

U.S. Fish and Wildlife Service. 1993. Grizzly Bear Recovery Plan. Missoula,:181.

Thier, T., and D. Sizemore. 1981. An Evaluation of Grizzly Relocations in the BGP Area. Missoula MT.

Thouless, C. R., and J. Sakwa. 1995. Shocking Elephants: Fences and Crop Raiders in Laikipia District, Kenya. *Biological Conservation* 72:99–107.

Treves, A., R. R. Jurewicz, L. Naughton-Treves, R. A. Rose, R. C. Willging, and A. P. Wydeven. 2002. Wolf Depredation on Domestic Animals in Wisconsin, 1976-2000. *Wildlife Society Bulletin* 30:231–241.

Wilson, S. M., M. J. Madel, D. J. Mattson, J. M. Graham, and T. Merrill. 2006. Landscape Conditions Predisposing Grizzly Bears to Conflicts on Private Agricultural Lands in the Western USA. *Biological Conservation* 130:47–59.

Woodroffe, R. 2000. Predators and People: Using Human Densities to Interpret Declines of Large Carnivores. *Animal Conservation* 3:165–173.

Figure 1. Grizzly bear recovery zones in the lower-48 States. (Photo: Interagency Grizzly Bear Committee)

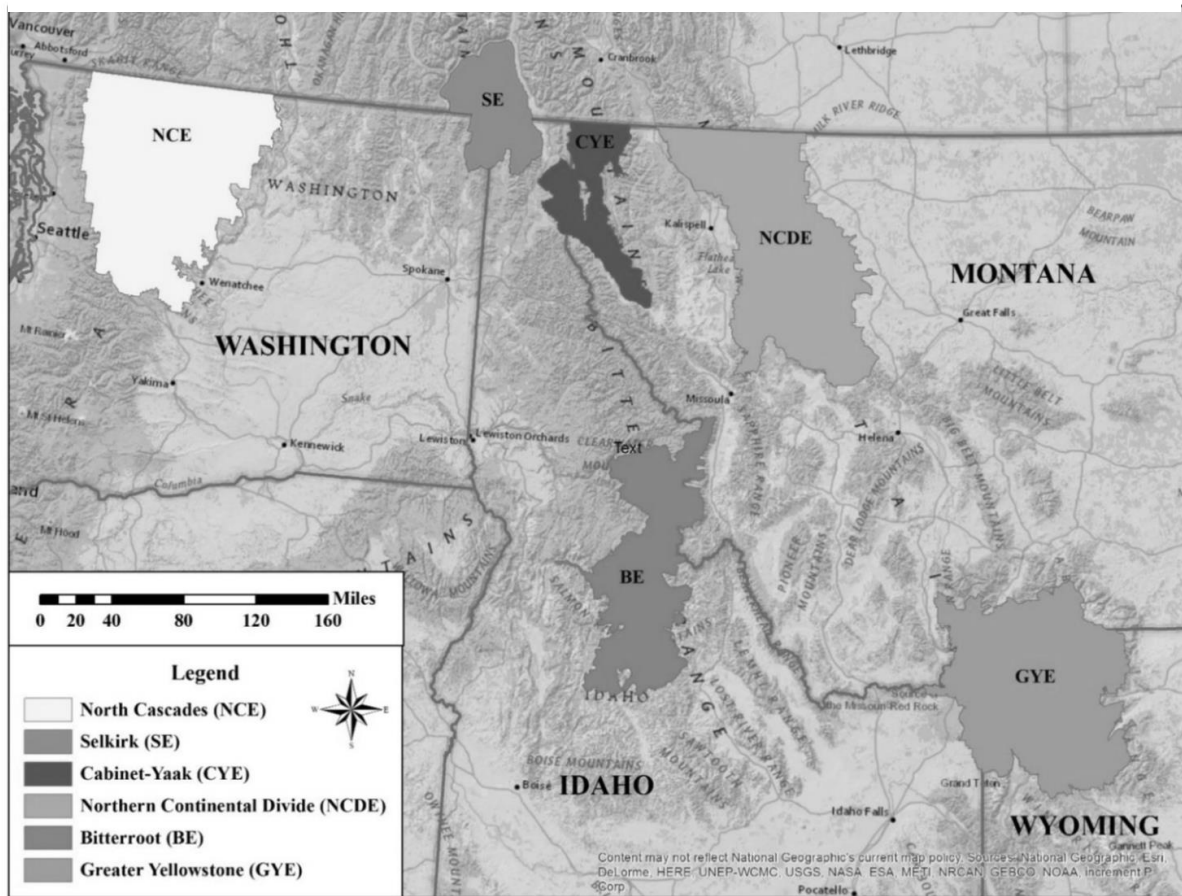

CHAPTER II: INFLUENCE OF LIVESTOCK ON HABITAT SELECTION OF GRIZZLY BEARS

18 May 2020
Kari L. Eneas
Confederated Salish Kootenai Tribes Wildlife Management Program
P.O. Box 278
Pablo, MT 59855
(406) 675 – 2700
Kari.Eneas@cskt.org

RH: Eneas et al. • Bear Habitat Selection

Influence of Livestock on Habitat Selection of Grizzly Bears

KARI L. ENEAS,¹² *Montana Cooperative Wildlife Research Unit, Wildlife Biology Program,
University of Montana, Missoula, Montana, 59812, USA*

MICHAEL MITCHELL, *U.S. Geological Survey, Montana Cooperative Wildlife Research Unit,
Wildlife Biology Program, University of Montana, Missoula, 59812, USA*

CHAD BISHOP, *WA Franke College of Forestry and Conservation, Wildlife Biology Program,
University of Montana, Missoula, 59812, USA*

STACY COURVILLE, *Confederated Salish Kootenai Tribes, Wildlife Management Program,
Pablo, MT, 59855, USA*

DALE BECKER, *Confederated Salish Kootenai Tribes, Wildlife Management Program, Pablo,
MT, 59855, USA*

¹ *Email:* Kari.Eneas@cskt.org

² *Current Affiliation:* Confederated Salish Kootenai Tribes, Wildlife Management Program, Pablo, MT 59855, USA

ABSTRACT When encounters between carnivores and livestock or humans result in conflict, the safety of both wildlife and humans are at risk. Reducing livestock depredation by grizzly bears (*Ursus arctos horribilis*) will be important as populations continue to recover in the Northern Continental Divide Ecosystem and expand beyond public lands. We used GPS locations from 8 female grizzly bears over 5 years in the Mission Valley, Montana to evaluate the effect of livestock on habitat selection of grizzly bears. The Mission Valley is located on the Flathead Indian Reservation where grizzly bears have been historically revered; however, modern cultural diversity complicates current management. We found a positive relationship in habitat selection for streams and wetlands by grizzly bears. We found that bears did not select for livestock, and that livestock did not have an effect on selection of streams or densities of homes or roads. Results were consistent with our hypothesis that habitat selection by grizzly bears in the Mission Valley is not strongly associated with livestock. Maps based on our results can be used to identify how and where electric fencing, bear resistant garbage bins and other conflict mitigation efforts could be focused.

KEY WORDS depredation, grizzly bear, habitat selection, livestock, Mission Valley, *Ursus arctos horribilis*

Encounters between carnivores and livestock or humans can result in conflict, including livestock depredation (Halfpenny et al. 1991; Thouless and Sakwa 1995; Woodroffe 2000; Treves et al. 2002, 2004; Naughton-Treves et al. 2003). This depredation can lead to the lethal-removal of depredating carnivores (Blanchard and Knight 1995; McLellan et al. 1999). Predicting where and why livestock depredations occur is important to reducing conflict (Treves et al. 2011; Northrup et al. 2012). Habitat selection models can identify environmental features associated with the presence of a carnivore (Nielsen et al. 2004) and thus identify areas where preventative actions might be taken to reduce conflict.

A long history of conflict exists between humans and grizzly bears (*Ursus arctos horribilis*; Mattson and Merrill 2002; Wilson et al. 2006; Northrup et al. 2012). Following region-wide population declines, primarily due to habitat loss and conflicts between humans and grizzly bears, the grizzly bear was listed as threatened under the Endangered Species Act in 1975. With distribution reduced to less than 2% of historical range in the lower-48 States, recovery zones were established where grizzly bears still persisted or had in the recent past (USFWS 1993). These areas were mostly roadless and undisturbed habitats in protected public lands such as Yellowstone National Park, Glacier National park, and designated Wilderness areas (USFWS 1993). Early population studies in the Northern Continental Divide Ecosystem (NCDE) estimated a population size of 240 – 300 grizzly bears (Kendall et al. 2008). Populations in the NCDE have increased in numbers to over 1,000 bears. (Costello et al. 2016; Peck et al. 2017). As populations of grizzly bears recover and expand their range (Costello and Roberts 2019), bears travel farther from public areas on to private and agricultural lands (Morehouse and Boyce 2017).

Human homes, roads, riparian vegetation and canopy cover can influence behavior of grizzly bears and chances of conflict (Wilson et al. 2005, 2006; Morehouse and Boyce 2017). Using resource selection functions (RSFs), Wilson et al (2005, 2006) and Northrup et al. (2012) found that grizzly bears select habitat in proximity to riparian vegetation, and that they tend to avoid areas with high densities of homes and roads. They also concluded that the presence of these features explained broad patterns of conflicts between grizzly bears and humans. These studies defined conflict broadly as any reported sighting or encounter with a grizzly bear, which included observing a bear in the yard, property damage or livestock depredation. Whereas recovery efforts for the grizzly bear include reducing the potential for encounters between

humans and grizzly bears related to bear mortality (USFWS 1993), preventing conflicts, including livestock depredation, will be important in a landscape with increasing human and bear populations. With this knowledge, our study additionally looked at habitat selection of grizzly bears in relation to small livestock to determine whether or not livestock depredations were intentional (i.e., caused by bears seeking out livestock as food), or whether depredations occurred opportunistically (i.e., caused by proximity to habitats selected by bears). Small livestock was chosen over large livestock (such as cows and horses) because of the lower costs associated with putting smaller livestock into protected enclosures or paddocks during the night. This provides opportunities for mitigation strategies like electric fencing to exclude bears and prevent depredation. Understanding where and why depredation happens can guide where management strategies like electric fencing, bear resistant garbage bins and other conflict mitigation efforts can be focused.

Whereas grizzly bears are omnivores and diets vary among individuals by age, location and season, bears can be largely herbivorous (Mace and Jonkel 1986; Schwartz et al. 2003; Teisberg et al. 2015). Although grizzly bears will forage on berries, insects, grasses, bulbs and roots for protein, they may also consume animal matter when its available to them (Brannon et al. 1988; Schwartz et al. 2003). Large acres of land being transitioned into fields of corn, as well as chickens; goats; pigs and llamas being raised next to residential home sites has contributed to recent surges of conflict in the Mission Valley. Rich agricultural history and the resurgence of small farms have created a landscape ripe for grizzly bear conflicts throughout the NCDE (Stacy Courville, CSKT Wildlife Biologist, personal communication).

Managing conflict is costly, as methods are time-consuming and complex (Linnel et al. 1997; Karanth and Madhusudan 2002; Naughton-Treves et al. 2003; Schivik et al. 2003). Once grizzly

bears learn to depredate livestock, management actions can include relocation, which may happen more than once because bears often return to the same site or depredate livestock where released (Thier and Sizemore 1981; Harting et al. 1987; Riley et al. 2008); 56% of translocated grizzly bears return to further agricultural depredation (Riley et al. 2008). When a grizzly bear is repeatedly managed for conflict or depredation or shows aggressive behavior toward humans, management may include lethal actions. As human and bear populations continue to grow in the NCDE, conflict and livestock depredation will continue to increase. To reduce livestock depredations, we aimed to understand whether and how the presence of livestock influenced habitat selection by grizzly bears.

The Flathead Indian Reservation is part of the Demographic Monitoring Area (where population size and mortality limits are monitored) within the NCDE (NCDE Subcommittee 2019). The grizzly bear population in this ecosystem has increased in number and distribution to inhabit over 63,800 km² (Costello and Roberts 2019). Since 2015, Tribal wildlife managers of the Flathead Indian Reservation have responded to 36 conflicts between grizzly bears and livestock. Land on the reservation is owned by both tribal and non-tribal members. The people of the Confederated Salish and Kootenai Tribes (CSKT) have coexisted with grizzly bears since time immemorial. Values of fish and wildlife are influenced by traditional culture and subsistence living for many Tribal members (McDonald et al. 2005). Traditionally, Tribal members viewed their land as the bear's land first, and is, therefore, culturally important to honor, respect grizzly bears and live peacefully with them. Perspectives and tolerances toward grizzly bears and bear management has changed over time and can make mitigating conflicts difficult. The human population within Lake County, MT has been increasing 2 – 3 % each year, which means more developments and new residents that are potentially unfamiliar living with

wildlife species like the grizzly bear. The rearing of small livestock (e.g., chickens, goats, pigs, and llamas) in both rural and urban environments is common and increasing on the reservation, and small livestock are easy prey for grizzly bears. Whereas past studies have focused on all forms of conflict in the NCDE (Wilson et al. 2005, 2006; Northrup 2010; Northrup et al. 2012; Morehouse and Boyce 2017), we focused specifically on depredation of small livestock.

We evaluated whether grizzly bears intentionally sought out small livestock as food irrespective of livestock location, or if bears depredated opportunistically only where livestock were conveniently located near other environmental features important to grizzly bears (e.g., streams and wetlands, low densities of residential homes and roads, etc.; Wilson et al. 2005, 2006; Northrup 2010; Northrup et al. 2012). Cow parsnip (*Heracleum lanatum*), sedges, serviceberry (*Amelanchier*), chokecherry (*Prunus virginiana*), insects and apples are important food sources for grizzly bears in the Mission Valley (Mace and Jonkel 1986) and are found in riparian habitats. Animal matter, however, is higher in energy and more digestible than sedges and berries, and may be sought after to increase body mass for hibernation (Schwartz et al. 2003).

We tested two hypotheses, the first being that grizzly bears would intentionally seek out small livestock because they offer a valuable, easily obtained food resource. If true, we expected to find a higher probability of use by grizzly bear near livestock than for other environmental features important to grizzly bears. Because small livestock can be raised in yards near residential homes we predicted that, if selecting for livestock, bears would also use areas with higher densities of homes and roads. Alternatively, we hypothesized that if grizzly bears opportunistically depredated small livestock, we expected to find greater probability of use near natural foods found near streams and wetlands and a negative association with livestock and the density of homes and roads (Wilson et al. 2005; Northrup et al. 2012).

STUDY AREA

Our 574 km² study area was located in the Mission Valley, Montana, located on the Flathead Indian Reservation within Northwestern Montana's Rocky Mountain range (Figure 1). It was bounded on the west by Highway 93, on the east by the Mission Mountains Tribal Wilderness Area and to the north by Flathead Lake. The study area was a landscape mixed with private, State, Federal, Tribal, and agricultural lands; prairie pothole wetlands; and riparian corridors. Based on previous observations by local managers, grizzly bears in the Mission Valley used private and agricultural lands extensively. The Mission Valley in western Montana was chosen for this study because of the recurring small livestock depredations and the unique challenges conflict poses to the culture and traditions of the Confederated Salish Kootenai Tribal people.

The study area included the Mission Mountains, which are a part of the recovery zone in the grizzly bear recovery plan (USFWS 1993). Protected areas in the study area included the Mission Mountain Tribal Wilderness spanning 372 km² (McDonald et al. 2005). The Tribes also managed a Special Grizzly Bear Management Zone, 41 km² within the Mission Mountain Tribal Wilderness Area, which was closed seasonally from human use to minimize disturbance to grizzly bears and ensure human safety (McDonald et al. 2005).

METHODS

The CSKT Wildlife Management Program captured, collared, and collected GPS location data on 8 female grizzly bears from 2015 – 2019, totaling 13 bear-years. All captures followed methods and protocols approved by the University of Montana Institutional Animal Care and Use Committee (IACUC no. 021-18MMMCWRU-041718) and described by Jonkel and Interagency Grizzly Bear Guidelines (Interagency Grizzly Bear Committee 1986; Jonkel 1993).

Grizzly bears captured were fitted with Telonics GPS radio collars (Mesa, AZ). Because our GPS data were from different collar models across multiple years, interval fixes differed. GPS transmitters were programmed to sample between 0.5 hours to 3.5 hours. CSKT Wildlife Management Program also recorded location and date for livestock depredations by grizzly bears from 2015 – 2019.

We used ArcGIS 10.6 (ESRI 2010) to generate each covariate as a raster layer with 30-m resolution and derive Euclidean distances to the nearest feature for livestock, streams and wetlands. Environmental features included distance to livestock, distance to stream, distance to wetland, density of homes, and density of roads (Table 1). We reclassified datasets from USGS Geographic Data Service Center (USGS 1992, 2008a, 2008b) for streams, wetlands and roads. These layers have been internally updated by CSKT to reflect the current status on the Flathead Indian Reservation.

For livestock, we created a raster layer of data points by driving county roads in our study area to identify locations of small livestock. Whereas local distribution of homesites with livestock may vary seasonally or across years, distribution of livestock across the valley has remained relatively constant since 2015 (Stacy Courville, CSKT Wildlife Biologist, personal communication).

We used Program R (Team 2018) for analyses, including packages ‘sf’ and ‘raster’ (Hijmans 2017; Pebesma 2018) to scale and extract covariate features.

We considered a year to be between March 20 – October 31 to omit denning periods. Assuming bears were independent, we accounted for correlation between GPS locations and habitat selection heterogeneity by using each bear as the sampling unit in a two-staged within-home range habitat selection modeling approach (Fieberg et al. 2010; Northrup et al. 2012; Peck

et al. 2017). In the first stage, we included all bear GPS locations to specify the covariate structure of the RSF. We estimated utilization distribution (UDs) with a 99% Kernel Density Estimate home range based on used locations using package ‘amt’ (Signer et al. 2018). An equal number of randomly selected points in the study area were generated from within the home range using ‘R’.

We used these randomly generated points to define available locations in an RSF model (Boyce 2006; Wilson et al. 2006; Northrup et al. 2012). We evaluated correlation between environmental features using pairwise scatterplots from the ‘car’ package (Fox and Weisberg 2011) and Variance Inflation Factors (VIFs; Anderson et al. 2000; De Veaux et al. 2016). We used Akaike Information Criterion corrected for small sample size (AICc) to select the top predictive model (Anderson et al. 2001; Burnham and Anderson 2002). We tested internal goodness of fit using Spearman-rank correlations from 5-fold cross validation (Boyce et al. 2002).

We analyzed each bear-year separately in the second modeling stage (Figure 2; Peck et al. 2017). We estimated utilization distribution (UDs) with a 99% Kernel Density Estimate home range for each bear-year based on individual used locations. We generated randomly selected points in the study area from within the home range of each bear. Random points were equal in number to locations for each bear. We averaged the sampled means and variances from each of these 13 bear models to characterize population means and variances for within-home range habitat selection (Fieberg et al. 2010; Northrup et al. 2012; Peck et al. 2017). We predicted and mapped the probability of bear use for the study area (Figure 3).

RESULTS

Our survey of county roads yielded 92 homesites with small livestock in 2018. The top predictive model included distance to livestock, distance to stream, distance to wetland, density of homes and density of roads with an interaction term between livestock and each of the other covariates. The top predictive model performed with a weight of 1. The second-ranked model was weighted <0.01 with a ΔAICc of 168.

We found a strongly positive relationship with distance to streams (-0.74 ± 0.07 , $p = 0.00$) and a positive relationship with distance to wetlands (-0.20 ± 0.06 , $p = 0.19$; Table 2). We found a negative relationship in selection for distance to livestock (0.05 ± 0.18 , $p = 0.04$; Table 2). There was a positive association with density of homes (0.81 ± 0.19 , $p = 0.07$) and density of roads (0.21 ± 0.10 , $p = 0.20$; Table 2).

The mean distance of grizzly bear locations to the nearest stream was 169 m (SD = 211 m), 674 m (SD = 441 m) from the nearest wetland, and 1166 m (SD = 1428 m) from the nearest livestock. Bears used habitats with mean residential home densities of 11 homes per km^2 (SD = 8 homes per km^2) and mean road densities of 3 miles per km^2 (SD = 1 mile per km^2). The mean distances of the 92 sites with livestock to the nearest stream was 233 m (SD = 241 m). The mean of all sites with conflict to the nearest stream was 180 m (SD = 148 m).

DISCUSSION

When encounters between grizzly bears and livestock result in depredation, the safety of both bears and livestock are at risk. We evaluated whether or not livestock depredations occurred due to grizzly bears seeking livestock out as a food resource, or whether depredations occurred opportunistically where livestock were located near other environmental features important to

grizzly bears. Our results suggested that grizzly bears in the Mission Valley did not seek out livestock but instead sought areas close to streams and wetlands (Figure 2). Though we hypothesized that grizzly bears would seek out small livestock as a valuable high energy food resource, we found that bears did not. Habitat selection by grizzly bears suggested that they were selecting for riparian corridors, possibly due to the natural food resources they contained (Mace and Jonkel 1986). Locations of livestock depredation in the Mission Valley occurred within the same distance to streams and riparian corridors that were found to be used by grizzly bears. This suggested that depredations occurred opportunistically when livestock were near streams and riparian habitats. Results were inconsistent with our hypothesis that grizzly bears sought out livestock as a food resource. We found that livestock did not effect how grizzly bears were using important environmental features on the landscape in order to exploit livestock as a food resource.

Results were consistent with our alternative hypothesis that grizzly bears depredated small livestock opportunistically. While there were some distinct patterns of habitat selection, such as distance to streams and wetlands, there was quite a bit of variability in selection between individual bears (Figure 2). Some individuals were more likely to be near livestock and use areas with higher densities of homes and roads. Whereas livestock presence was not a good indicator of bear presence, results suggest grizzly bears are likely to select habitat near streams and wetlands. The overall median densities of homes and roads in the available areas of the Mission Valley were 3 homes per km^2 and 2 miles per km^2 for roads. Though we predicted that bears would avoid areas of housing developments, we found that bears frequently used areas with densities of 11 homes per km^2 . We observed this pattern throughout the entire year. Anthropogenic sources such as garbage and fruit trees may contribute to use in proximity to

homes. Higher use of these areas by grizzly bears may also be a result of many homes in the Mission Valley being within close proximity to riparian corridors; because bears were selecting for riparian corridors, this could have put them in proximity to more homes.

Key landscape features, such as distances to streams and wetlands, were found in previous studies to increase the risk of conflict (Wilson et al. 2005, 2006; Northrup et al. 2012). Whereas a majority of conflicts occurred over a small portion of the landscape in relation to these features (Wilson et al. 2005, 2006), the risk of conflicts between humans and grizzly bears were higher in areas where housing developments overlapped with riparian habitats (Northrup et al. 2012). Because the conflicts measured in these studies were broad and not specific to livestock depredation, however, we could not know if livestock depredations by grizzly bears occurred opportunistically, or were the result of grizzly bears seeking out livestock as a food resource. Similar to previous findings by Wilson et al. (2005, 2006) and Northrup et al. (2012), we found that livestock near riparian corridors had a higher risk of being depredated, even though grizzly bears were not seeking out livestock as a food resource. Riparian corridors provide natural foods and canopy cover, and thus, bears may be using them more than open areas.

These inferences are limited not only by sample size, but also by the fact that we were only able to collar female grizzly bears during our study period. Of the 8 collared females, 7 were caring for yearling or cubs-of-the-year. If we had been able to observe males and females without cubs we might have detected different patterns in selection. Our results showed that, while bears were found in relation to streams, a good amount of residential homes with livestock in their back yards were also close to streams. Yet, our sampled bears were not depredating livestock. With a larger sample size, we would expect some bears might engage in depredation at sites without electrified fencing. We might also see more variation in selection, perhaps more

bears living in higher elevations with lower densities of homes and roads but also individuals more prone to live in areas with higher human disturbance. Because our questions were specific to conflicts in the valley, we targeted valley bears. All of the bears for this study were collared in the Mission Valley, and for the most part they stayed in the valley during summer months.

For several decades grizzly bear populations have been increasing in numbers and range extent (Peck et al. 2017; Costello and Roberts 2019). Whereas genetic connectivity between designated recovery areas remains a long-term management goal in grizzly bear management, locations of grizzly bears have increasingly been identified in areas between occupied ranges (Costello and Roberts 2019; Peck et al. 2017; NCDE Subcommittee 2019). For managers interested in reducing conflicts between humans and grizzly bears in these areas, we can expect that most conflicts in open landscapes with mixed private and public land ownership will occur in proximity to riparian habitat. Whereas livestock did not appear to attract bears or change their behavior in the Mission Valley, electrified fences may deter grizzly bears and prevent depredation of livestock as bears disperse between recovery zones. Human attitudes can change when landowners gain positive or negative firsthand experience with grizzly bears (Decker et al. 2012), so it will be important to reduce conflict in the areas between recovery zones. Grizzly bears prefer habitat close to streams, and livestock depredation can be reduced by focusing preventative, non-lethal mitigation tools like electric fencing along riparian habitats (Annis 2017; Eneas 2020).

Although different attitudes about grizzly bears exist on the Flathead Indian Reservation, proactive and non-lethal actions can be implemented by residents to minimize future conflicts between livestock and grizzly bears. Securing small livestock, agricultural crops and livestock feed inside of an electric fence can prevent conflict (Annis 2017; Johnson 2018; Eneas 2020).

Eneas (2020) found that grizzly bears in the Mission Valley did not depredate small livestock protected by electrified fencing; livestock was 50% more likely to be depredated without an electrified fence. Though few landowners were interested in protecting livestock with electric fences, this mitigation tool can deter additional predators such as black bear, fox and skunk from depredating livestock as well (Eneas 2020). The reason landowners are hesitant to use electric fences is unknown, but cost-share programs do exist to help reduce the financial burden of installing electric fences.

ACKNOWLEDGMENTS

We thank personnel from the Confederated Salish Kootenai Tribes Wildlife Management Program and Montana Fish Wildlife and Parks who contributed to the collection of data used in this study. We also thank Swan Valley Connections for collar retrieval, as well as Defenders of Wildlife and People and Carnivores for promoting outreach and providing resources for electric fences for Mission Valley Residents. This study was funded by the CSKT Wildlife Management Program, University of Montana Wildlife Biology Program, Alfred P. Sloan Foundation, and Vital Ground Foundation. We appreciate the review comments from S. Sells and J. Fortin-Noreus.

LITERATURE CITED

- Anderson, D. R., K. P. Burnham, and W. L. Thompson. 2000. Null Hypothesis Testing: Problems, Prevalance, and an Alternative. *Journal of Wildlife Management* 64:912–923.
- Anderson, D. R., W. A. Link, D. H. Johnson, and K. P. Burnham. 2001. Suggestions for Presenting the Results of Data Analysis. *The Journal of Wildlife Management* 65:373–378.

- Annis, K. 2017. *Deterring Bears with Electrified Fencing : A beginner ' s guide.*
- Blanchard, B. M., and R. R. Knight. 1995. Biological Consequences of Relocating Grizzly Bears in the Yellowstone Ecosystem. *The Journal of Wildlife Management* 59:560.
- Boyce, M. S. 2006. Scale for Resource Selection Functions. *Diversity and Distributions* 12:269–276.
- Boyce, M. S., P. R. Vernier, S. E. Nielsen, and F. K. A. Schmiegelow. 2002. Evaluating Resource Selection Functions. *Ecological Modelling* 157:281–300.
- Burnham, K. P., and D. R. Anderson. 2002. *Model Selection and Multimodal Inference: A Practical Information-Theoretic Approach.* Second Edi. Springer-Verlag New York, New York, New York.
- Costello, C.M., R.D. Mace, L. Roberts. 2016. *Grizzly Bear Demographics in the Northern Continental Divide Ecosystem, Montana: Research Results (2004-2014) and Suggested Techniques for Management of Mortality.* Helena.
- Costello, C. M., and L. L. Roberts. 2019. *Northern Continental Divide Ecosystem Grizzly Bear Monitoring Team Annual Report, 2018.* 490 N. Meridian Road, Kalispell, MT 59901.
- Decker, D. J., S. J. Riley, and W. F. Siemer. 2012. *Human Dimensions of Wildlife Management.* 2nd edition. The Johns Hopkins University Press, Baltimore, Maryland.
- De Veaux, R. D., P. F. Vellemean, and D. E. Bock. 2016. *STATS Data & Models.* 4th edition. Pearson Education Inc

- Eneas, K. 2020. Influence of Livestock and Electrified Fences on Livestock Depredation and Habitat Selection by Grizzly Bears in the Mission Valley, Montana. University of Montana. Thesis. Missoula, MT.
- Fieberg, J., J. Matthiopoulos, M. Hebblewhite, M. S. Boyce, and J. L. Frair. 2010. Correlation and Studies of Habitat Selection : Problem , Red Herring or Opportunity ? Philosophical Transactions of the Royal Society B: Biological Sciences 365:2233–2244.
- Fox, J., and S. Weisberg. 2011. An {R} Companion to Applied Regression. Sage, Thousand Oaks, CA.
- Halfpenny, J. C., M. R. Sanders, and K. A. McGrath. 1991. Human-Lion Interactions in Boulder County, Colorado: Past, Present and Future. Pages 10–16 in Mountain lion-human interaction symposium and workshop. Colorado Division of Wildlife, Denver.
- Harting, A. L., M. N. LeFrاند, and I. G. B. C. (U.S.). 1987. Grizzly Bear Compendium. Natural Wildlife Federation, University of Michigan.
- Hijmans, R. J. 2017. raster: Geographic Data Analysis and Modeling.
- Interagency Grizzly Bear Committee. 1986. Interagency Grizzly Bear Guidelines. Publisher not identified, Place of publication not identified.
- Johnson, B. J. 2018. Permeability of Three-strand Electric Fences by Black Bears and Grizzly Bears. Montana State University.
- Jonkel, J. J. 1993. A Manual for Handling Bears for Managers and Researchers. Office of Grizzly Bear Recovery Coordinator, U.S. Fish and Wildlife Service, Missoula MT.

- Karanth, K. U., and M. D. Madhusudan. 2002. *Mitigating Human-Wildlife Conflicts in Southern Asia*. Island Press, Covelo, California.
- Kendall, K. C., J. B. Stetz, D. A. Roon, L. P. Waits, J. B. Boulanger, D. Paetkau. 2008. Grizzly Bear Density in Glacier National Park. *Journal of Wildlife Management* 72:8 1693-1705.
- Kendall, K. C., J. B. Stetz, J. Boulanger, A. C. Macleod, D. Paetkau, and G. C. White. 2009. Demography and Genetic Structure of a Recovering Brown Bear population. *Journal of Wildlife Management* 73:3–17.
- Linnel, J. D. C., R. Aanes, J. E. Swenson, J. Odden, and S. M. E. 1997. Translocation of Carnivores as a Method for Managing Problem Animals: a Review. *Biodiversity and Conservation* 6:1245–1257.
- Mace, R. D., and C. J. Jonkel. 1986. Local Food Habits of the Grizzly Bear in Montana. *International Conference on Bear Research and Management* 6:105–110.
- Mattson, D. J., and T. Merrill. 2002. Extirpations of Grizzly Bears in the Contiguous United States. *Conservation Biology* 16:1123–1136.
- McDonald, T., T. Tanner, L. BigCrane, and D. Rockwell. 2005. *Mission Mountain Tribal Wilderness: A Case Study*. Confederated Salish and Kootenai Tribes, Pablo, MT.
- McLellan, B. N., F. W. Hovey, R. D. Mace, J. G. Woods, D. W. Carney, M. L. Gibeau, W. L. Wakkinen, and W. F. Kasworm. 1999. Rates and Causes of Grizzly Bear Mortality in the Interior Mountains of British Columbia, Alberta, Montana, Washington, and Idaho. *The Journal of Wildlife Management* 63:911.

- Morehouse, A. T., and M. S. Boyce. 2017. Troublemaking Carnivores: Conflicts with Humans in a Diverse Assemblage of Large Carnivores. *Ecology and Society* 22.
- Naughton-Treves, L., R. Grossberg, and A. Treves. 2003. Paying for Tolerance: Rural Citizens; Attitudes toward Wolf Depredation and Compensation. *Conservation Biology* 17:1500–1511.
- Nielsen, S. E., S. Herrero, M. S. Boyce, R. D. Mace, B. Benn, M. L. Gibeau, and S. Jevons. 2004. Modelling the Spatial Distribution of Human-Caused Grizzly Bear Mortalities in the Central Rockies Ecosystem of Canada. *Biological Conservation* 120:101–113.
- Northrup, J. M., G. B. Stenhouse, and M. S. Boyce. 2012. Agricultural Lands as Ecological Traps for Grizzly Bears. *Animal Conservation* 15:369–377.
- Northrup, J. N. 2010. Grizzly Bears, Roads, and Human-Bear Conflicts in Southwestern Alberta. University of Alberta, Edmonton, AB, Canada.
- Pebesma, E. 2018. sf: Simple Features for R. R package version 0.6-2.
- Peck, C. P., F. T. VanManen, C. M. Costello, M. A. Haroldson, L. A. Landenburger, L. L. Roberts, D. D. Bjornlie, and R. D. Mace. 2017. Potential Paths for Male-Mediated Gene flow to and from an Isolated Grizzly Bear Population. *Ecosphere* 8.
- Riley, S. J., K. Aune, R. D. Mace, and M. J. Madel. 2008. Bears in Northwestern Montana. *Management* 9:567–573.
- Schivik, J. A., A. Treves, and P. Callahan. 2003. Nonlethal Techniques for Managing Predation: Primary and Secondary Repellents. *Conservation Biology* 17:1531–1537.

- Schwartz, C. C. ., S. D. . Miller, and M. A. Haroldson. 2003. Grizzly Bear. Pages 556–586 in G. A. . Feldhamer, B. C. . Thompson, and J. A. Chapman, editors. *Wild Mammals of North America: Biology, Management, and Conservation*. Second ed. Johns Hopkins University Press, Baltimore, Maryland.
- Signer, J., J. Fieberg, and T. Avgar. 2018. *Animal Movement Tools (amt) R-Package for Managing Tracking Data and Conducting Selection Analyses*.
- Sizemore, D. L. 1980. *Foraging Strategies of the Grizzly Bear as Related to its Ecological Energetics*. The University of Montana.
- NCDE Subcommittee. 2019. *Conservation Strategy for the Grizzly Bear in the Northern Continental Divide Ecosystem*.
- Team, R. C. 2018. *R: A Language and Environment for Statistical Computing*. R Foundation for Statistical Computing, Vienna, Austria.
- Teisberg, J. E., M. J. Madel, R. D. Mace, C. W. Serhveen, C. T. Robbins. 2015. *Diet Composition and Body Condition of Northern Continental Divide Grizzly Bears*. Final Report.
- Thier, T., and D. Sizemore. 1981. *An Evaluation of Grizzly Relocations in the BGP Area*. Missoula MT.
- Thouless, C. R., and J. Sakwa. 1995. *Shocking Elephants: Fences and Crop Raiders in Laikipia District, Kenya*. *Biological Conservation* 72:99–107.
- Treves, A., R. R. Jurewicz, L. Naughton-Treves, R. A. Rose, R. C. Willging, and A. P.

- Wydeven. 2002. Wolf Depredation on Domestic Animals in Wisconsin, 1976-2000. *Wildlife Society Bulletin* 30:231–241.
- Treves, A., and L. Naughton-Treves. 1999. Risk and Opportunity for Humans Coexisting with Large Carnivores. *Journal of Human Evolution* 36:275–282.
- Treves, A., L. Naughton-Treves, E. K. Harper, D. J. Mladenoff, R. A. Rose, T. A. Sickley, and A. P. Wydeven. 2004. Predicting Human-Carnivore Conflict: A Spatial Model Derived from 25 Years of Data on Wolf Predation on Livestock. *Conservation Biology* 18:114–125.
- Treves, A. T., K. A. Matrin, A. P. Wydeven, and J. E. Wiedenhoef. 2011. Forecasting Environmental Hazards and the Application of Risk Maps to Predator Attacks on Livestock. *Bioscience* 61:451–458.
- U.S. Fish and Wildlife Service. 1993. Grizzly Bear Recovery Plan. Missoula, :181.
- U.S. Geological Survey. 1992. ROADS. Geographic Data Service Center.
- U.S. Geological Survey. 2008a. COVERAGE Streams. Geographic Data Service Center.
- U.S. Geological Survey. 2008b. COVERAGE Wetland. Geographic Data Service Center..
- Wilson, S. M., M. J. Madel, D. J. Mattson, J. M. Graham, J. A. Burchfield, and J. M. Belsky. 2005. Natural Landscape Features, Human-Related Attractants, and Conflict Hotspots: a Spatial Analysis of Human–Grizzly Bear Conflicts. *Ursus* 16:117–129.
- Wilson, S. M., M. J. Madel, D. J. Mattson, J. M. Graham, and T. Merrill. 2006. Landscape Conditions Predisposing Grizzly Bears to Conflicts on Private Agricultural Lands in the Western USA. *Biological Conservation* 130:47–59.

Woodroffe, R. 2000. Predators and People: Using Human Densities to Interpret Declines of Large Carnivores. *Animal Conservation* 3:165–173.

Figure 1. The Flathead Indian Reservation and study area (shaded in green) used for evaluating habitat selection of grizzly bears in the Mission Valley, MT.

Figure 2. Plot of sample means and 95% confidence intervals from individual bear resource selection functions for female grizzly bears during 2015 – 2019 in the Mission Valley, Montana.

Figure 3. Resource selection Function (RSF) predictions of habitat selected by female grizzly bears in the study area during the years 2015 – 2019. Color gradient based probabilities of bear use from model covariates. A) Locations of 36 confirmed small livestock depredations by grizzly bears during 2015 – 2019. B) Distribution of 92 small livestock sites in the Mission Valley, MT. C) Streams in the Mission Valley, MT.

Table 1. Descriptions and hypothesis predictions for all environmental features included in resource selection functions modeling habitat selection of grizzly bears in the Mission Valley, MT between the years 2015 – 2019.

Covariates	Description	Intentional Depredation Hypothesis	Opportunistic Depredation Hypothesis
Distance from livestock	Distance (m) from nearest site with one or more small livestock species (chicken, goat, pig, llama)	Grizzly bears will seek out small livestock because they offer a high-caloric, easily obtained food resource.	Grizzly bears do not seek out small livestock, but instead select for other important environmental features.
Distance from Stream	Distance (m) from nearest stream	Grizzly bears will not select habitat in proximity to streams, but rather select for proximity to small livestock	Grizzly bears will select habitat for natural food found in proximity to streams.
Distance from Wetland	Distance (m) from nearest wetland ≥ 1 acre	Grizzly bears will not select habitat in proximity to wetlands, but rather select for proximity to small livestock	Grizzly bears will select habitat for natural food found in proximity to wetlands.
Density of Homes	Density of residential homesites per km ²	Grizzly bears will select habitat in areas with higher densities of residential homesites due to the rearing of livestock in back yards	Grizzly bears will avoid areas with residential development
Density of Roads	Density of all primary and secondary road types per km ²	Grizzly bears will select habitat in areas with higher densities of roads, due to rearing of livestock in back yards	Grizzly bears will avoid areas with higher densities of roads.

$\bar{X} \pm SD$

Individual Bear Model	$\bar{X} \pm SD$									
	Livestock	Stream	Wetland	Home	Road	*Stream	*Wetland	*Home	*Road	
A ₁₇	0.69±.46	-0.68±.09	-0.29±.09	-0.87±.40	0.68±.14	0.06±.08	0.60±.11	-2.91±.48	2.58±.32	
C ₁₈	0.24±.18	-0.17±.05	-0.16±.045	1.00±.12	-1.12±.09	0.70±.07	-0.12±.06	0.21±.20	0.36±.14	
C ₁₉	0.65±.21	-0.33±.06	-0.01±.04	0.64±.14	-0.27±.07	0.13±.02	-0.22±.06	0.01±.19	0.83±.13	
E ₁₅	0.77±.20	-1.59±.16	-0.19±.11	1.78±.25	-0.62±.13	0.09±.14	-0.73±.14	1.26±.26	0.50±.10	
E ₁₆	1.28±.14	-0.75±.06	-0.08±.05	1.13±.18	0.23±.06	0.83±.06	-0.08±.06	0.91±.18	0.91±.18	
E ₁₇	0.68±.13	-0.68±.05	-0.27±.04	1.09±.18	-0.01±.06	0.34±.05	-0.22±.05	1.11±.19	-0.01±.07	
E ₁₈	-1.59±.26	-0.63±.10	-0.72±.11	3.21±.51	-4.75±.37	-0.30±.12	0.45±.11	2.88±.43	-2.65±.26	
K ₁₈	0.66±.20	-0.53±.06	-0.54±.06	1.20±.31	0.16±.09	0.08±.08	0.39±.07	1.26±.34	0.04±.14	
K ₁₉	-1.58±.21	-0.09±.03	-0.21±.04	0.44±.12	-0.35±.05	0.16±.05	0.13±.06	0.29±.27	-0.78±.09	
M ₁₈	-1.13±.08	-0.78±.06	-0.32±.05	0.39±.07	0.29±.05	0.20±.05	0.23±.06	-0.48±.05	-0.25±.06	
P ₁₈	0.39±.09	-0.77±.08	0.03±.07	0.39±.13	-0.05±.12	50±.08	0.51±.09	0.47±.13	-0.39±.11	
S ₁₈	0.05±.04	-0.91±.04	0.18±.03	0.15±.04	-0.17±.04	0.00±.04	0.08±.03	0.17±.04	0.30±.04	
T ₁₈	-0.46±.08	-0.91±.05	-0.01±.06	-0.01±.07	0.01±.07	-0.07±.06	0.28±.05	-0.32±.08	-0.10±.06	
M _{Average}	0.05±.18	-0.74±.07	-0.2±.06	0.81±.19	0.21±.10	0.1±.07	0.37±.07	-0.46±.22	0.07±.13	
p-value	0.04	0.00	0.19	0.07	0.20	0.18	0.02	0.12	0.14	

Table 2. Results of individual and averaged resource selection function sample means and variances of all covariates from 8 female grizzly bears in the Mission Valley, MT during 2015 – 2019.

Figure 1. The Flathead Indian Reservation and the study area (shaded in green) used for evaluating habitat selection of grizzly bears in the Mission Valley, MT.

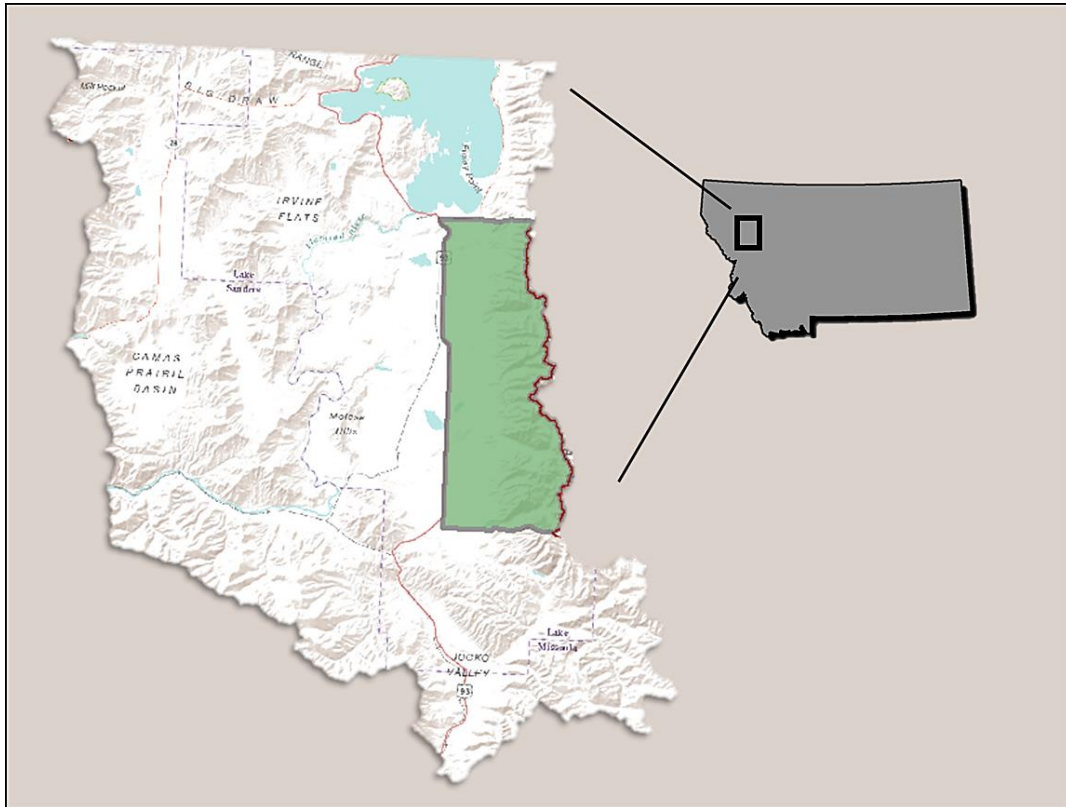

Figure 2. Plot of sample means and 95% confidence intervals from individual bear resource selection functions for female grizzly bears during 2015 – 2019 in the Mission Valley, Montana. Each bear-year is identified by a different color.

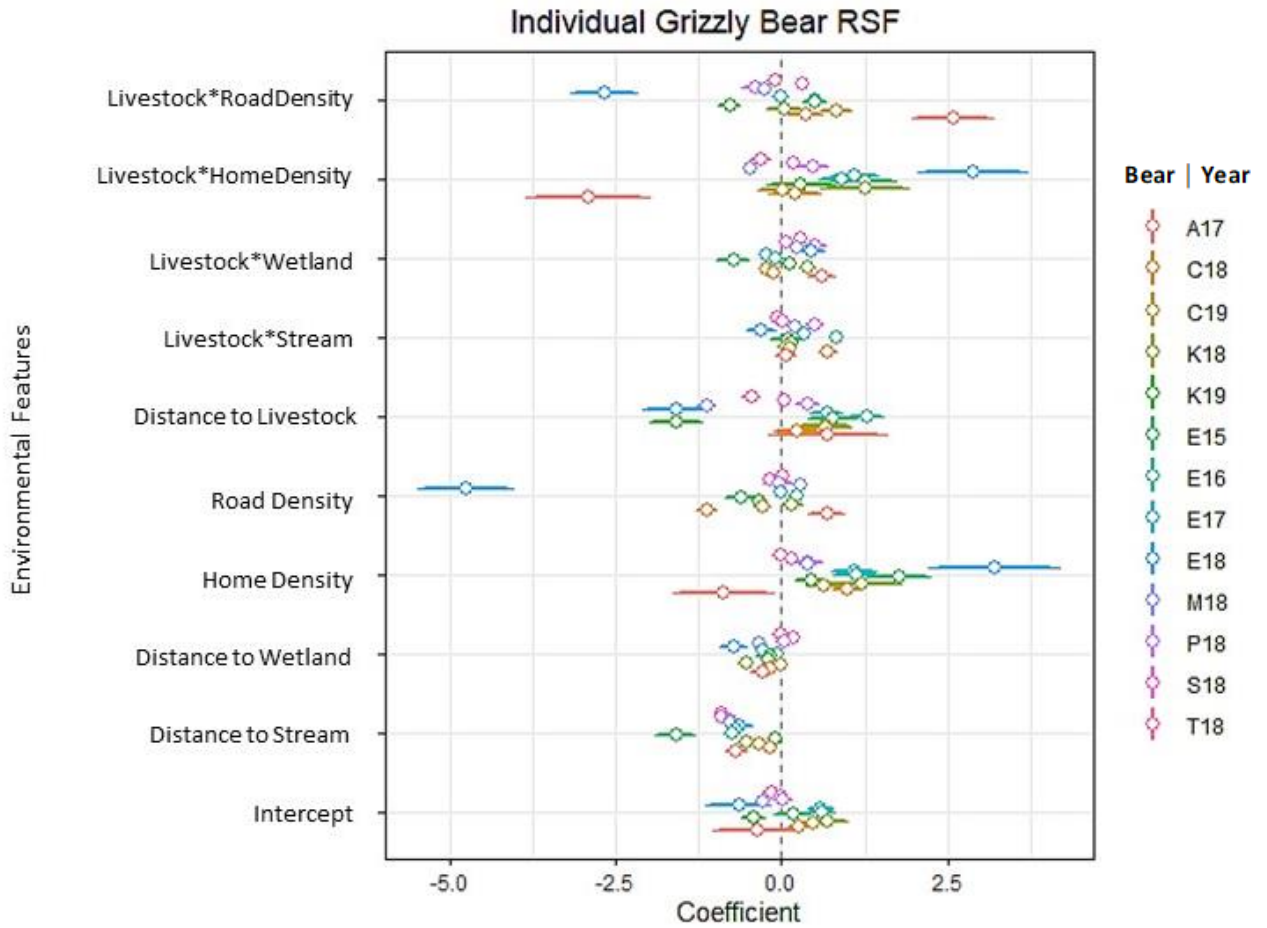
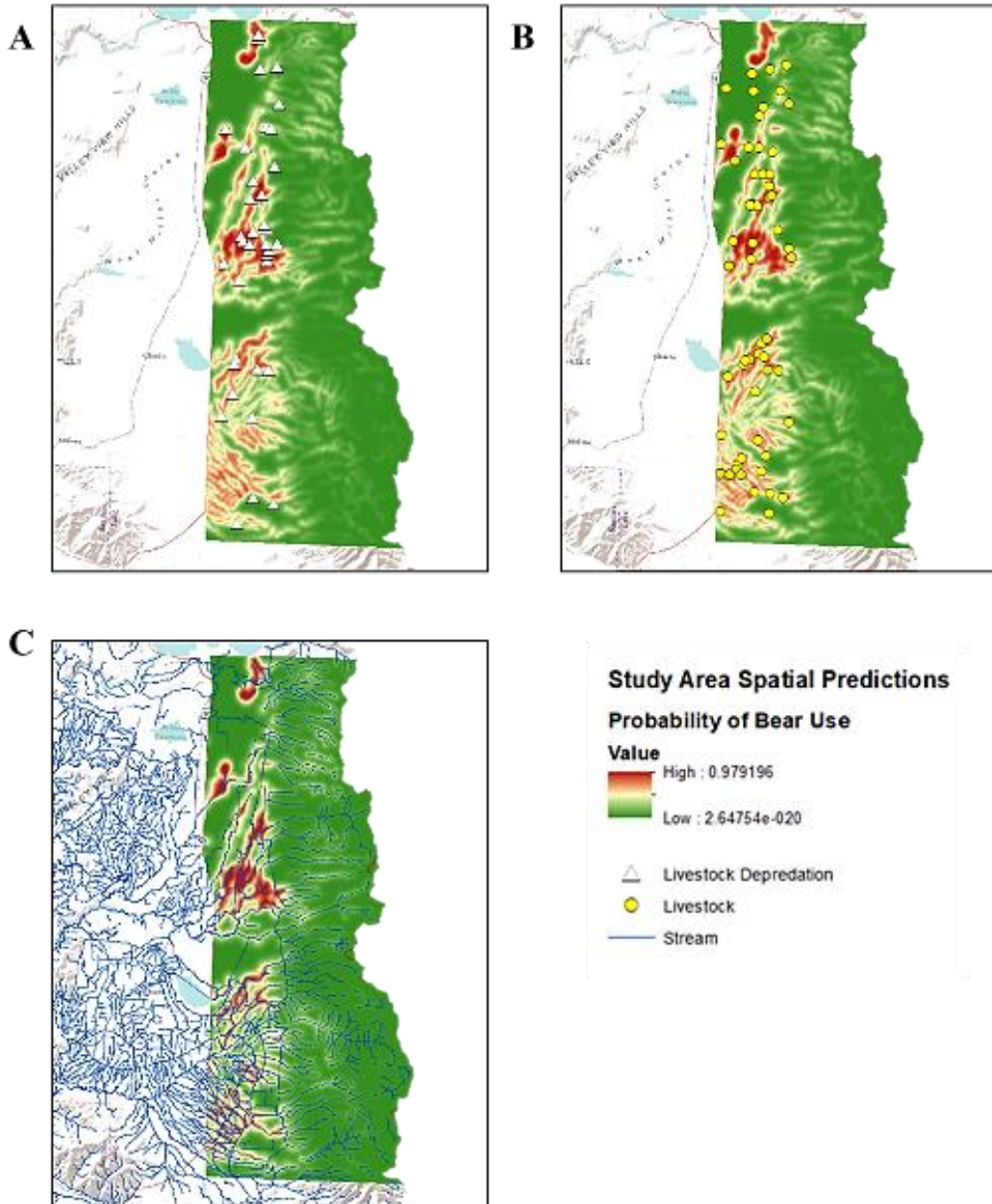

Figure 3. Resource selection Function (RSF) predictions of habitat selected by female grizzly bears in the study area during the years 2015 – 2019. Color gradient based probabilities of bear use from model covariates. A) Locations of 36 confirmed small livestock depredations by grizzly bears during 2015 – 2019. B) Distribution of 92 small livestock sites in the Mission Valley, MT. C) Streams in the Mission Valley, MT



CHAPTER III: USING ELECTRIC FENCES TO PREVENT LIVESTOCK DEPREDACTION BY GRIZZLY BEARS

18 May 2020

Kari L. Eneas

Confederated Salish Kootenai Tribes Wildlife Management Program

P.O. Box 278

Pablo, MT 59855

(406) 675-2700

Kari.Eneas@cskt.org

RH: Eneas et al. • Grizzly Bear Livestock Depredation

Using Electric Fences to Prevent Livestock Depredation by Grizzly Bears

KARI L. ENEAS,³⁴ *Montana Cooperative Wildlife Research Unit, Wildlife Biology Program,*

University of Montana, Missoula, Montana, 59812, USA

MICHAEL MITCHELL, *U.S. Geological Survey, Montana Cooperative Wildlife Research Unit,*

Wildlife Biology Program, University of Montana, Missoula, 59812, USA

CHAD BISHOP, *WA Franke College of Forestry and Conservation, Wildlife Biology Program,*

University of Montana, Missoula, MT 59812, USA

STACY COURVILLE, *Confederated Salish Kootenai Tribes, Wildlife Management Program,*

Pablo, MT 59855, USA

DALE BECKER, *Confederated Salish Kootenai Tribes, Wildlife Management Program, Pablo,*

MT 59855, USA

³ *Email:* Kari.Eneas@cskt.org

⁴ *Current Affiliation:* *Confederated Salish Kootenai Tribes, Wildlife Management Program, Pablo, MT 59855, USA*

ABSTRACT Balancing protection between livestock and carnivores has been a long-standing challenge in conservation. Reducing livestock depredation by grizzly bears (*Ursus arctos horribilis*) will be important as populations recover and expand beyond protected areas in the Northern Continental Divide Ecosystem. Whereas electric fencing has been frequently used to protect bee apiaries from depredation by bears in North America, they have only recently been used to protect crops and livestock against grizzly bears. We identified 20 small livestock sites with electrified fencing and 72 sites that were unfenced in 2018. We monitored 12 electrified fences surrounding small livestock and recorded the presence and behaviors of grizzly bears at these sites in the Mission Valley during 2018 – 2019. No depredations occurred when livestock were inside a properly functioning electric fence and 7 livestock depredations occurred at sites without electrified fencing, suggesting that electric fences were a highly effective tool at reducing livestock depredations by grizzly bears.

KEY WORDS depredation, electrified fence, grizzly bear, livestock, Mission Valley, *Ursus arctos horribilis*

Balancing protection between livestock and grizzly bears (*Ursus arctos horribilis*) has been a challenge in conservation (McLellan et al. 1999; Wilson et al. 2006; Decker et al. 2012). Human-dominated landscapes have a high volume of artificial and reliable high-calorie foods, such as garbage, fruit trees, bird feeders and livestock, that can attract bears and cause conflict (McLellan et al. 1999; Morehouse and Boyce 2017; Wilbur et al. 2018). These encounters can affect wildlife and human safety (Halfpenny et al. 1991; Thouless and Sakwa 1995; McLellan et al. 1999; Treves and Karanth 2003; Morehouse and Boyce 2017). Avoiding food conditioning of grizzly bears to attractants can avert many negative impacts (Decker et al. 2012). Whereas electric fencing has been frequently used to protect bee apiaries from depredation by bears in

North America (Jorgensen et al. 1978; Lord and Ambrose 1981), they have only recently been used to protect crops and livestock against grizzly bears (Wilson et al. 2014; Johnson 2018).

Following region-wide population declines, the grizzly bear was listed as threatened under the Endangered Species Act in 1975 (USFWS 1993). As populations of grizzly bears recover and expand their range (Costello and Roberts 2019; Kendall et al. 2009; Peck et al. 2017), grizzly bears travel farther from public areas into private and agricultural lands (Morehouse and Boyce 2017). When human contact with grizzly bears is infrequent, beliefs and attitudes about them may be based on secondhand interactions with potential for misinformation or misperceptions about associated risks and impacts (Decker et al. 2012). This can leave a mismatch between perceptions of risk and actual degree of risk in conflict by grizzly bears, including livestock depredation (Sunstein 2015).

Cultural values and histories can also influence an individual's perception of conflict (Nyhus 2016). The Flathead Indian Reservation is part of the Demographic Monitoring Area (where population size and mortality limits are monitored) within the Northern Continental Divide Ecosystem (NCDE) (NCDE Subcommittee 2019; Costello et al. 2016). The people of the Confederated Salish and Kootenai Tribes (CSKT) have traditionally viewed their land as belonging to the grizzly bear first and have coexisted with grizzly bears since time immemorial. Perspectives and tolerances toward grizzly bears and bear management has changed over time and can make mitigating conflicts difficult.

Studies by Wilson et al. (2005; 2006), Northrup et al. (2010; 2012) and Eneas (2020) have found that grizzly bears use habitat in riparian areas near streams and wetlands. The presence of homes and other developments in these corridors explain broad patterns of conflict between grizzly bears and humans (Wilson et al. 2005, 2006; Northrup et al. 2012; Eneas 2020). Bears

use natural food resources found in riparian corridors, such as serviceberry (*Amelanchier*); chokecherry (*Prunus virginiana*); and cow parsnip (*Heracleum lanatum*) (Mace and Jonkel 1987). When small livestock (e.g., chickens, goats, pigs, llamas) are closer to riparian habitats, risk of opportunistic depredation by grizzly bear increases (Eneas 2020). We studied small livestock rather than large livestock (such as cows and horses) because of the lower costs associated with putting smaller livestock into enclosures or paddocks during the evening hours. This provides opportunities for mitigation strategies exclude bears and prevent depredation.

Finding effective methods to reduce levels of livestock depredation can improve local attitudes toward grizzly bears and bear conservation (Huygens and Hayashi 1999). Properly designed electrified fences have been used to deter bears from beehives, garbage and small livestock (Annis 2017; Johnson 2018). Ability to customize use and installation is achievable with both temporary and permanent electric fence designs. When an animal touches an electrified fence, the electric current passes through the animal to the ground, and back to the energizer through the ground rod. This completed electrical current results in the animal being shocked (Annis 2017). Montana Fish, Wildlife and Parks describe an effective fence as having a minimum of 5 alternating hot and ground wires with a stored joule rating of 0.7-1.0 (Annis 2017). Grizzly bears require 6,500-7,000 volts at a rate of 45-60 pulses per minute to be deterred (Annis 2017). Similar fences were effective at deterring grizzly bears from calving and lambing pastures (Madel 1996) and have been recommended to minimize conflicts associated with livestock, bee yards, and boneyards in Montana (Wilson et al. 2005, 2006).

Whereas electric fencing has been used to prevent depredation of apiaries, few studies have formally measured success of electrified fences in protecting small livestock from grizzly bears. To better understand the efficacy of electric fences at protecting small livestock, we evaluated

whether properly functioning electrified fences would deter bears from depredating livestock. Due to the success of deterring bears from apiaries and boneyards, we hypothesized that grizzly bears would be successfully deterred by electrified fences and not depredate livestock at sites with proper electric fencing. We predicted, therefore, that the probability of depredation at sites with electrified fences would be lower than sites without electrified fences. Alternatively, if grizzly bears were not deterred by electric fences, we expected probabilities of depredation at sites with electrified fences to be similar to sites without.

STUDY AREA

Our 574 km² study area was located in the Mission Valley, Montana, located on the Flathead Indian Reservation within Northwestern Montana's Rocky Mountain range (Figure 1). It was bounded on the west by Highway 93, on the east by the Mission Mountains Tribal Wilderness Area and to the north by Flathead Lake. The study area was a landscape mixed with private, State, Federal, Tribal, and agricultural lands; prairie pothole wetlands; and riparian corridors.

Based on previous observation, grizzly bears in the Mission Valley used private and agricultural lands extensively. The study area included the Mission Mountains, which are a part of the NCDE recovery zone from the grizzly bear recovery plan. Protected areas in the Mission Mountain include the Mission Mountain Tribal Wilderness, spanning 372 km² (McDonald et al. 2005). The Tribes also manage a Special Grizzly Bear Management Zone, 41 km² within the Mission Mountain Tribal Wilderness Area, which was closed seasonally from human use to minimize disturbance to grizzly bears and ensure human safety (McDonald et al. 2005).

METHODS

We created a raster layer of small livestock data points by driving county roads in our study area to identify locations of small livestock. Each site was recorded as having an electrified fence

surrounding livestock, or not. The CSKT Wildlife Management Program recorded location and date for livestock depredations by grizzly bears during 2015 – 2019. We only included depredations that occurred within our study area.

We used package ‘pander’ (Daroczi 2018) to analyze probabilities of livestock depredation. Eneas (2020) modeled probabilities of grizzly bear use on distances to streams, wetlands, livestock, and densities of homes and roads (Eneas 2020). We used these probabilities to designate classes of risk for livestock depredation during 2015 – 2019. Using ArcGIS (ESRI 2010), we classified bear use between 0 – 0.13 as class 1 (Low risk), bear use between 0.14 – 0.42 as class 2 (Medium risk) and bear use between 0.43 – 0.98 as class 3 (High risk). We used Program R (Team 2018) packages ‘sf’ and ‘raster’ (Hijmans 2017; Pebesma 2018) to extract risk classes. Because there was no probability of depredation at sites with electrified fences, we removed them from this portion of analysis and only used the 72 unprotected livestock sites to determine probabilities of depredation by risk class.

During May – October of 2018 – 2019 we monitored 4 permanent and 1 temporary electrified fence previously constructed by landowners. During the summer of 2018, we constructed 6 additional permanent and 1 temporary electrified fences for a total of 10 permanent and 2 temporary fences. Landowner approval of fence and camera installation determined site selection. At sites where electric fences previously existed, we checked for proper energizers and monitored for proper function, but did not re-build the fences. For fences we installed, we used Speedrite 1000 UNIGIZER 1.0 Joule energizers (New Zealand) in both permanent and temporary style electrified fences (Figure 2). We constructed permanent fences using t-posts, existing wooden posts, or attached the fence to existing structures where necessary. Using Gallagher multi-post pinlock fence insulators, we hung 5 lines of polywire. We set the bottom

wire 8 – 12 inches above the ground and the top wire 36 – 42 inches above the ground. We pounded a ½ inch thick grounding rod made of galvanized steel 3 – 6 feet into the ground (depending on ground moisture). We attached 6 of the fences directly to power sources, and 6 to Speedrite 1000 solar powered energizer systems using energizer connector clips. We alternated hot and ground wires starting with the bottom so both the top and bottom wires were hot (Figure 2). For a temporary style electrified fence we installed 82' and 164' Kencove electric netting (Figure 2; Blairsville, PA), which consisted of 12 alternating hot and ground horizontal lines with vertical lines every 7". We selected these fences for the 40" height and easy step-in double spiked fiberglass posts.

From May 1 to October 31 of each year, we monitored 9 chicken coops, 1 goat pen, 1 pig pen and 1 llama paddock for grizzly bear presence and activity with motion activated Bushnell trophy cam HD Agressor game cameras (Figure 3; Overland Park, Kansas). We set each camera to take one photo followed by 60 seconds of video. To limit accidental captures of landowners and pets, we only recorded activity during night hours between 6pm and 6am. We visited sites every 3 – 4 weeks to download camera data, conduct any fence maintenance and measure voltage. Videos were reviewed and date, time of day, total visit time and behavior were recorded. Behavior consisted of a bear passing by the fence, approaching but not touching the fence, successfully breaching the fence and touching a fence receiving a shock.

RESULTS

In the Mission Valley, 92 sites were identified with small livestock; 20 sites had electric fencing. Of the 72 sites that did not have electrified fencing, depredation of livestock occurred at 36 sites during 2015 – 2019. The mean distance from all livestock to the nearest stream was 233 m (SD = 241 m) and all depredation sites to the nearest stream during was 180 m (SD = 148 m).

When protected with electrified fencing, there was no probability of livestock depredation, and this was because there were no occurrences of conflict at the 20 sites that had electric fencing in place. The probability of livestock depredation at sites with no electric fence was 50% (Table 1). There was no relationship between probability of depredation and risk class (Low = 45%, Med = 47% High = 52%).

The CSKT Wildlife Management Program responded to 4 depredations of livestock in the study area during 2018 and 3 depredations during 2019. Of these depredations, 5 occurred at locations with previous conflict. Of the 12 monitored sites protected with electric fencing, there were two instances of depredation when livestock were not put inside the electrified fence, and one depredation event at a site where the homeowner did not have the fence turned on.

The mean distance from these 12 monitored and protected small livestock sites to the nearest riparian habitat was 183 m (SD = 181 m); grizzly bear presence was observed at 4 of them. This distance overlaps with the mean distance of grizzly bears to the nearest riparian habitat (169 m, Eneas 2020). Based on GPS collar data, an adult female with three young of the year cubs used riparian habitat bordering a 5th site where we monitored an electrified pig pen. No GPS or camera data captured the bears near the pen. At a 6th site, a fenced chicken coop less than 35 m from a heavily used riparian corridor had a collared adult female with two young of the year cubs travel the corridor 27 times in 2018. Neither GPS nor camera data captured them at the chicken coop.

We recorded 12 occasions of grizzly bear presence at monitored livestock sites with electrified fencing; 3 visits in 2018 and 9 visits in 2019. We had 4 bears pass by a fence without approaching, 5 bears approached, but did not touch, the fence, 3 bears successfully breached a fence and 0 bears touched a hot fence (Table 2). All of the successful breaches of an electric

fence occurred when the fence was not electrified; only one breach resulted in depredation. Grizzly bears that passed by electric fences were at chicken coops, and bears approached but did not touch the electrified fence at sites with chicken, goats and llamas (Table 2).

We recorded presence of other predator species at sites with small livestock as well. We observed black bear (19), fox (36), coyote (27), raccoon (38), and skunk (12). Of these observations, we observed one black bear and one raccoon touch and receive a shock from the electrified fence. All other observations were of animals passing by or approaches that aborted the attempt before touching the fence. Overall, grizzly bears were detected less frequently at these sites than other local predators.

DISCUSSION

Depredation of livestock continues to be a challenge in grizzly bear management. Few studies have tested how effective electric fences were at preventing livestock depredation by grizzly bears near riparian areas. We found that no bear depredated livestock when livestock were inside a properly functioning fence. When there was no electric fence, the probability of depredation increased (Table 1), and we observed 7 depredations in the study area at sites without electrified fencing. Observations indicated that electrified fences that are turned on and functioning properly are effective at preventing depredation by grizzly bears. Fences were not effective when livestock were not put inside of them. None of the grizzly bears that approached an electrified fence touched the wire, but turned away and continued passing by. Electric fences prevented depredation attempts by one black bear and one raccoon. Based on observations of non-target species, the benefit of using electric fences to protect small livestock may extend to other predators (e.g., black bear, skunk, raccoon, fox, coyote).

Both the temporary and permanent fences were effective at preventing depredation. The design of each fence type was easy to customize to fit the needs of each site. Fences were connected to existing chicken coop structures, constructed around smaller pastures for goats and pigs, and around larger perimeters for llamas. Each of the fences required regular weed trimming and voltage checks over the season. To maintain 6,500+ volts, we repaired the netting of temporary fences after having large debris blown into them, and cut grass around each perimeter to prevent the fence from grounding on vegetation.

Our sample of electric fences in the study area were small. Though we offered to install free electrified fences, few landowners were interested in using them to protect their livestock. We believe our results are representative, however, because the opportunity for grizzly bear conflict with humans, including depredation of livestock, was high in the Mission Valley (Figure 4). Grizzly bears used the Mission Valley extensively between May – October, yet most were unnoticed by residents.

Whereas the probability of livestock depredation was 50% without an electrified fence, it is possible that the cost of a high energy food reward is low in the absence of fences and bears are more likely to depredate small livestock. When an electric fence is present, however, the cost of the same food reward is much higher and grizzly bears may avoid the food reward, which is reflected in our 0% probability of depredation with an electric fence. Additional attractants, such as unsecured garbage and compost, can also attract bears to sites with livestock. We recorded multiple occasions of black bear, raccoon, coyote and grizzly bear raiding such attractants in the week prior to a depredation that occurred at one of our monitored sites. The depredation occurred when the electric fence was not turned on.

We weren't only interested in measuring how well electric fences deterred grizzly bears, but also wanted to know how likely depredation events were in areas of high, medium and low grizzly bear use. Though no relationship was detected between risk class and the probability of depredation, these results do suggest that it is important to protect livestock in all risk classes. Knowing that grizzly bears do strongly select for distances to streams (Eneas 2020), the modeled probabilities of bear use (Eneas 2020) that we used to determine risk class included additional covariates such as distances wetlands, livestock and the densities of homes and roads. Risk classes, therefore, were not a direct measure of distance to riparian corridors. Had we modeled distances of streams separately as risk class, we would expect to have found a stronger relationship between risk class and probability of livestock depredation. It is important to note that the highest number of unprotected livestock sites occurred in areas of high grizzly bear use (Table 1). This indicates that livestock occurs abundantly in areas that grizzly bears frequently use.

Human attitudes can change when people gain positive or negative firsthand experience with depredation or conflict (Decker et al. 2012). For example, if a landowner experiences depredation after not properly maintaining or turning on an electric fence, that landowner might experience distrust in fencing as an effective method for preventing conflict. Additionally, when a landowner perceives their risk of an event such as depredation as lower than the actual risk, they may choose to forgo certain behaviors like installing an electric fence to prevent depredation from happening (Sunstein 2015). If their past experience has not included such an event, this misperception is likely to become greater (Ajzen and Fishbein 1980; Heberlein 2012; Sunstein 2015). Many bears in the Mission Valley live among people unnoticed (Figure 4). We can see that many residential home sites occur within areas used by bears, yet none of these

collared bears exhibited conflict or depredation behaviors at these home sites in the study area. Coexisting with grizzly bears is happening, however, when a bear happens upon unprotected livestock in riparian corridors, there is potential for depredation. And livestock depredation is a behavior that is difficult for a bear to unlearn. That is where using non-lethal methods such as electrified fencing to protect livestock could help in reducing conflicts by grizzly bears.

Whereas cost-share programs exist for livestock owners to help reduce the financial burden associated with installing an electrified fence, it remains difficult to convince landowners to use electric fences. Residents of the Mission Valley often think of bears in the Mission Mountains, but do not realize that grizzly bears use the valley so extensively. Additionally, some tribal members viewed their property as home to the grizzly bear first, and therefore were not bothered by depredation of their livestock. These realities may explain why so few landowners were interested in electric fences. Landowners unwilling to protect small livestock with electrified fencing is a huge hurdle for reducing livestock depredation. Grizzly bears will continue to opportunistically depredate small livestock near riparian corridors that are unprotected by an electric fence, even if a handful of sites are protected. Though different attitudes about grizzly bears exist on the Flathead Indian Reservation, using electric fences in the Mission Valley will likely reduce livestock depredation.

ACKNOWLEDGMENTS

We extend much gratitude to the private landowners who participated in this project, as well as personnel from the Confederated Salish Kootenai Tribes Wildlife Management Program and Montana Fish Wildlife and Parks who contributed to the collection of data used in this study. We also thank Defenders of Wildlife and People and Carnivores for promoting outreach and providing resources for electric fences for Mission Valley Residents. This study was funded by

the CSKT Wildlife Management Program, University of Montana Wildlife Biology Program, Alfred P. Sloan Foundation, and Vital Ground Foundation.

LITERATURE CITED

Ajzen, I., and M. Fishbein. 1980. *Understanding Attitudes and Predicting Social Behavior*. 6th ed. Prentice-Hall, Englewood Cliffs, N.J.

Annis, K. 2017. *Deterring Bears with Electrified Fencing : A beginner ' s guide*.

Boyce, M. S., J. A. Pitt, J. M. Northrup, A. T. Morehouse, K. H. Knopff, B. Cristescu, and G. B. Stenhouse. 2010. Temporal Autocorrelation Functions for Movement Rates from Global Positioning System Radiotelemetry Data. *Philos Trans R Soc Lond B Biol Sci* 365:2213–2219.

Costello, C.M., R.D. Mace, L. Roberts. 2016. *Grizzly Bear Demographics in the Northern Continental Divide Ecosystem, Montana: Research Results (2004-2014) and Suggested Techniques for Management of Mortality*. Helena.

Daroczi, G. 2018. *pander: An R “Pandoc” Writer*.

Decker, D. J., S. J. Riley, and W. F. Siemer. 2012. *Human Dimensions of Wildlife Management*. 2nd edition. The Johns Hopkins University Press, Baltimore, Maryland.

Eneas, K. 2020. *Influence of Livestock and Electrified Fences on Livestock Depredation and Habitat Selection by Grizzly Bears in the Mission Valley, Montana*. University of Montana. Thesis. Missoula, MT.

- Hebberlein, T. A. 2012. *Navigating Environmental Attitudes*. Oxford University press, New York.
- Hijmans, R. J. 2017. *raster: Geographic Data Analysis and Modeling*.
- Huygens O. C. and Hayashi, H. 1999. Using Electric Fences to Reduce Asiatic Black Bear Depredation in Nagano Prefecture, Central Japan. *Wildlife Society Bulletin* 27:959–964.
- Johnson, B. J. 2018. *Permeability of Three-strand Electric Fences by Black Bears and Grizzly Bears*. Montana State University.
- Jorgensen, C. J., R. H. Conley, R. J. Hamilton, and O. T. Sanders. 1978. Management of Black Bear Depredation Problems. Pages 297–319 in *Proceedings of the Eastern Black Bear Workshop*.
- Kendall, K. C., J. B. Stetz, J. Boulanger, A. C. Macleod, D. Paetkau, and G. C. White. 2009. Demography and Genetic Structure of a Recovering Brown Bear population. *Journal of Wildlife Management* 73:3–17.
- Lord, W. G., and J. T. Ambrose. 1981. Black Bear Depredation of Beehives in the United States and Canada. *American Bee Journal* 121:811–815.
- Mace, R. D. ., and C. J. Jonkel. 1986. Local Food Habits of Grizzly Bear in Montana. *International Conference on Bear Research and Management* 6:105–110.
- Madel, M. J. 1996. *Rocky Mountain Front Grizzly Bear Management Program Four-year Progress Report*. Helena, Montana, USA.

- McDonald, T., T. Tanner, L. BigCrane, and D. Rockwell. 2005. Mission Mountain Tribal Wilderness: A Case Study. Confederated Salish and Kootenai Tribes, Pablo, MT.
- McLellan, B. N., F. W. Hovey, R. D. Mace, J. G. Woods, D. W. Carney, M. L. Gibeau, W. L. Wakkinen, and W. F. Kasworm. 1999. Rates and Causes of Grizzly Bear Mortality in the Interior Mountains of British Columbia, Alberta, Montana, Washington, and Idaho. *The Journal of Wildlife Management* 63:911.
- Morehouse, A. T., and M. S. Boyce. 2017. Troublemaking Carnivores: Conflicts with Humans in a Diverse Assemblage of Large Carnivores. *Ecology and Society* 22.
- NCDE Subcommittee. 2013. NCDE Grizzly Bear Conservation Strategy.
- Northrup, J. M., G. B. Stenhouse, and M. S. Boyce. 2012. Agricultural Lands as Ecological Traps for Grizzly Bears. *Animal Conservation* 15:369–377.
- Northrup, J. N. 2010. Grizzly Bears, Roads, and Human-Bear Conflicts in Southwestern Alberta. University of Alberta, Edmonton, AB, Canada.
- Nyhus, P. J. 2016. Human-Wildlife Conflict and Coexistence. *Annual Review of Environment and Resources* 41:143–171.
- Pebesma, E. 2018. sf: Simple Features for R. R package version 0.6-2.
- Peck, C. P., F. T. VanManen, C. M. Costello, M. A. Haroldson, L. A. Landenburger, L. L. Roberts, D. D. Bjornlie, and R. D. Mace. 2017. Potential Paths for Male-Mediated Gene flow to and from an Isolated Grizzly Bear Population. *Ecosphere* 8.

- Sunstein, C. R. 2015. Behavioral Economics, Consumption, and Environmental Protection. Edward Elgar Publishing Limited, Northampton.
- Team, R. C. 2018. R: A Language and Environment for Statistical Computing. R Foundation for Statistical Computing, Vienna, Austria.
- U.S. Fish and Wildlife Service. 1993. Grizzly Bear Recovery Plan. Missoula, MT.
- Wilbur, R. C., S. A. Lischka, J. R. Young, and H. E. Johnson. 2018. Experience, Attitudes, and Demographic Factors Influence the Probability of Reporting Human-Black Bear Interactions. *Wildlife Society Bulletin* 42:22–31.
- Wilson, S. M., M. J. Madel, D. J. Mattson, J. M. Graham, J. A. Burchfield, and J. M. Belsky. 2005. Natural Landscape Features, Human-Related Attractants, and Conflict Hotspots: a Spatial Analysis of Human–Grizzly Bear Conflicts. *Ursus* 16:117–129.
- Wilson, S. M., M. J. Madel, D. J. Mattson, J. M. Graham, and T. Merrill. 2006. Landscape Conditions Predisposing Grizzly Bears to Conflicts on Private Agricultural Lands in the Western USA. *Biological Conservation* 130:47–59.
- Wilson, S. M., G. A. Neudecker, and J. J. Jonkel. 2014. Chapter 6: Human-Grizzly Bear Coexistence in the Blackfoot River Watershed, Montana. Pages 177–195 in S. G. Clark and R. M. B., editors. *Large Carnivore Conservation: Integrating Science and Policy in the North American West*. University of Chicago Press, Chicago.

Figure 1. Study area in Mission Valley, MT, displaying locations of 12 sites observed for grizzly bear presence during the summers of 2018 and 2019.

Figure 2. Two fence designs used in the study. A) Permanent design was modeled after Montana Fish, Wildlife and Parks specifications for grizzly bear deterrence (Annis 2017). B) Temporary fence design designed with Kencove electrified netting (Blairsville, PA).

Figure 3. Positioning of cameras used for monitoring grizzly bear behavior at small livestock sites protected with electrified fencing. Cameras were placed on opposite ends of the fences and positioned between 25 – 35 feet away from the fence to cover a wide viewing radius.

Figure 4. Figure 4. Maps showing locations of 8 female grizzly bears, livestock and houses in the Mission Valley during the years 2015 – 2018. Bear locations were taken between March 20 – October 31 of each year. Bears used areas near residential homes frequently, yet none of these collared bears were involved in conflict or livestock depredation at these home sites during this study.

Table 1. Probabilities of livestock depredation by grizzly bears at sites in the Mission Valley, MT with and without electrified fencing during the years 2018 – 2019.

Fence Status	Conflict Status	Freq.	All	Probability
No Fence	No Conflict	36	72	50%
No Fence	Conflict	36	72	50%
Electrified Fence	No Conflict	20	20	100%

Risk Class	Conflict Status	Freq.	All	Probability
1	No Conflict	6	11	55%
1	Conflict	5	11	45%
2	No Conflict	8	15	53%
2	Conflict	7	15	47%
3	No Conflict	22	46	48%
3	Conflict	24	46	52%

Table 2. Results of grizzly bear observations at small livestock sites protected with electrified fencing during the summers of 2018 and 2019 in the Mission Valley, MT.

Bear Behavior:	Passed By	Approached	Breached	Touched Fence
Fence On	4	5	-	-
Fence Off	-	-	3	-
Behavior by Livestock Type:				
Chicken coop	4	2	3	-
Goat pen	-	1	-	-
Pig pen	-	-	-	-
Llama paddock	-	2	-	-

***Note: the 3 successful passes occurred when electric fence was turned off**

Figure 1. Study area in Mission Valley, MT (shaded in green) displaying locations of 12 sites observed for grizzly bear presence during the summers of 2018 – 2019.

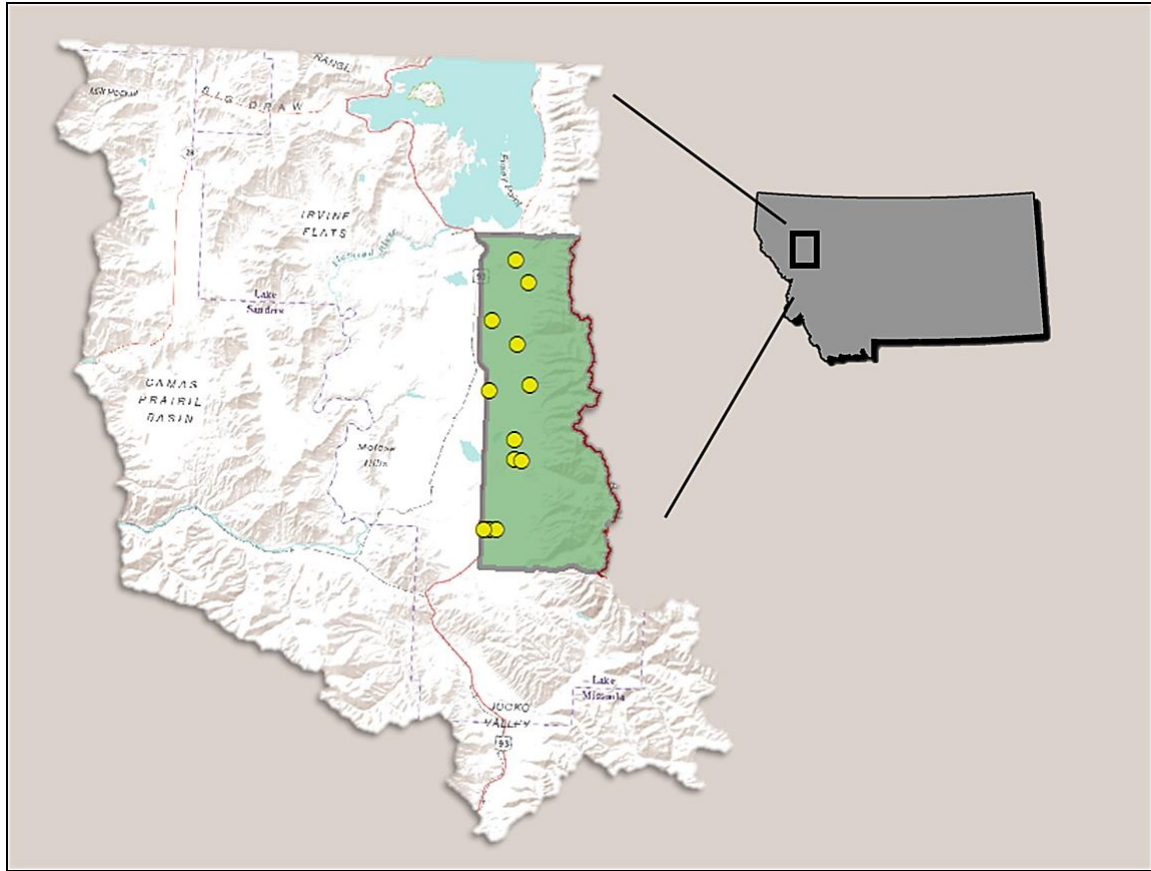

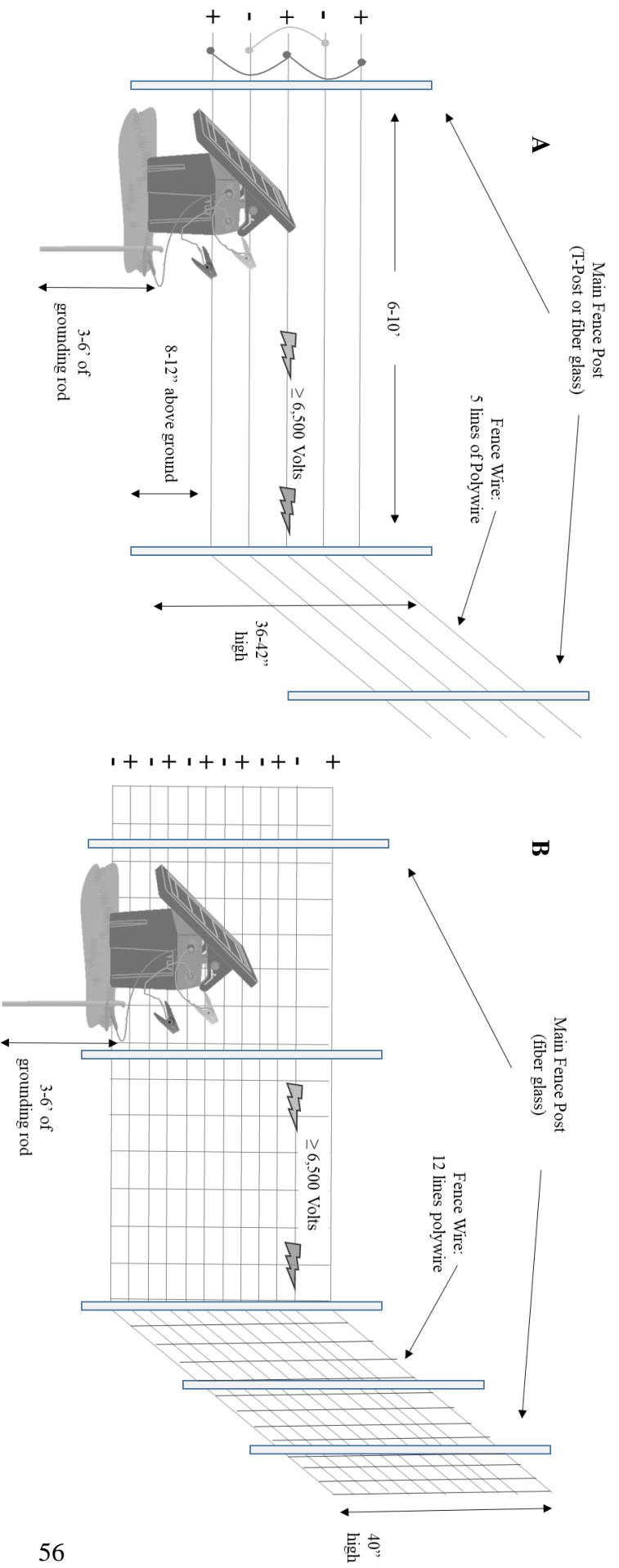

Figure 2. Two fence designs used in the study. A) Permanent design was modeled after Montana Fish, Wildlife and Parks specifications for grizzly bear deterrence (Annis 2017). B) Temporary fence design with Kencove electrified netting (Blairsville, PA).

Figure 3. Positioning of cameras used for monitoring grizzly bear behavior at small livestock sites protected with electrified fencing. Cameras were placed on opposite ends of the fences and positioned between 25 – 35 feet away from the fence to cover a wide viewing radius.

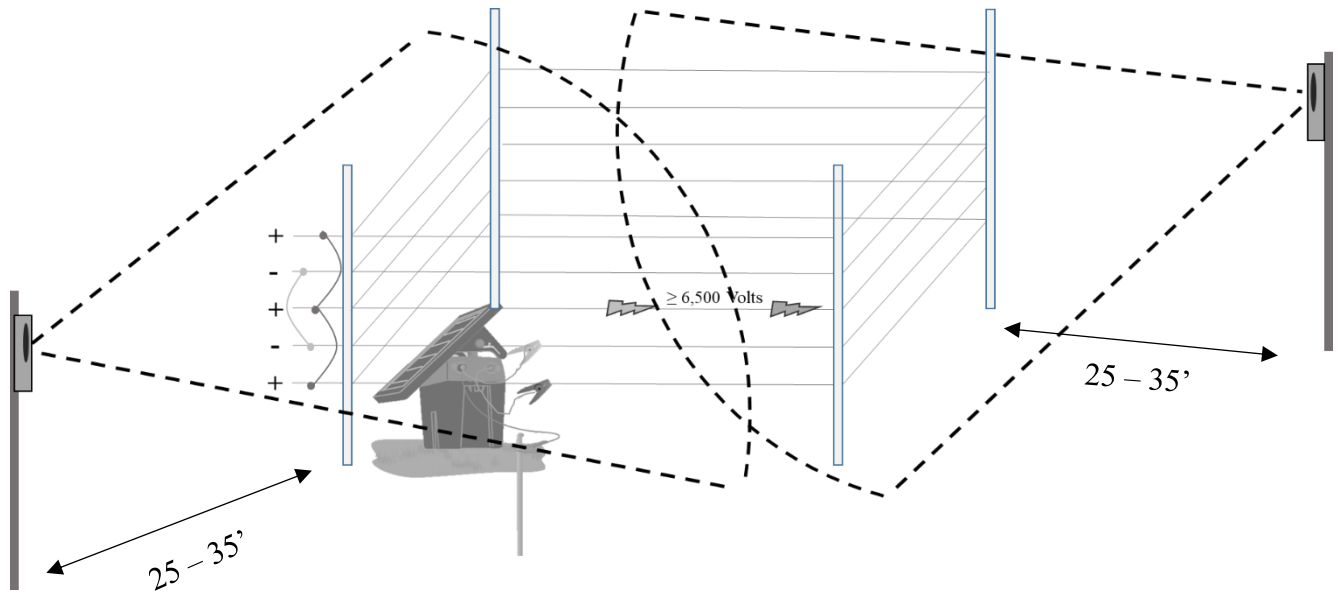

Figure 4. Maps showing locations of 8 female grizzly bears, livestock and houses in the Mission Valley during the years 2015 – 2018. Bear locations were taken between March 20 – October 31 of each year. Bears used areas near residential homes frequently, yet none of these collared bears were involved in conflict or livestock depredation at these home sites during this study.

