

James Madison University

JMU Scholarly Commons

Global CWD Repository

Center for International Stabilization and
Recovery

1-2005

Operational Evaluation Test of Mine Clearing Cultivator and Mine Clearing Sifter

Institute for Defense Analysis

U.S. Humanitarian Demining Research and Development
U.S. HD R&D

Office of the Assistant Secretary of Defense Special Operations and Low-Intensity Conflict

Follow this and additional works at: <https://commons.lib.jmu.edu/cisr-globalcwd>



Part of the [Defense and Security Studies Commons](#), [Peace and Conflict Studies Commons](#), [Public Policy Commons](#), and the [Social Policy Commons](#)

Recommended Citation

Analysis, Institute for Defense; and Development, U.S. Humanitarian Demining Research; and Low-Intensity Conflict, Office of the Assistant Secretary of Defense Special Operations and, "Operational Evaluation Test of Mine Clearing Cultivator and Mine Clearing Sifter" (2005). *Global CWD Repository*. 1438.

<https://commons.lib.jmu.edu/cisr-globalcwd/1438>

This Other is brought to you for free and open access by the Center for International Stabilization and Recovery at JMU Scholarly Commons. It has been accepted for inclusion in Global CWD Repository by an authorized administrator of JMU Scholarly Commons. For more information, please contact dc_admin@jmu.edu.

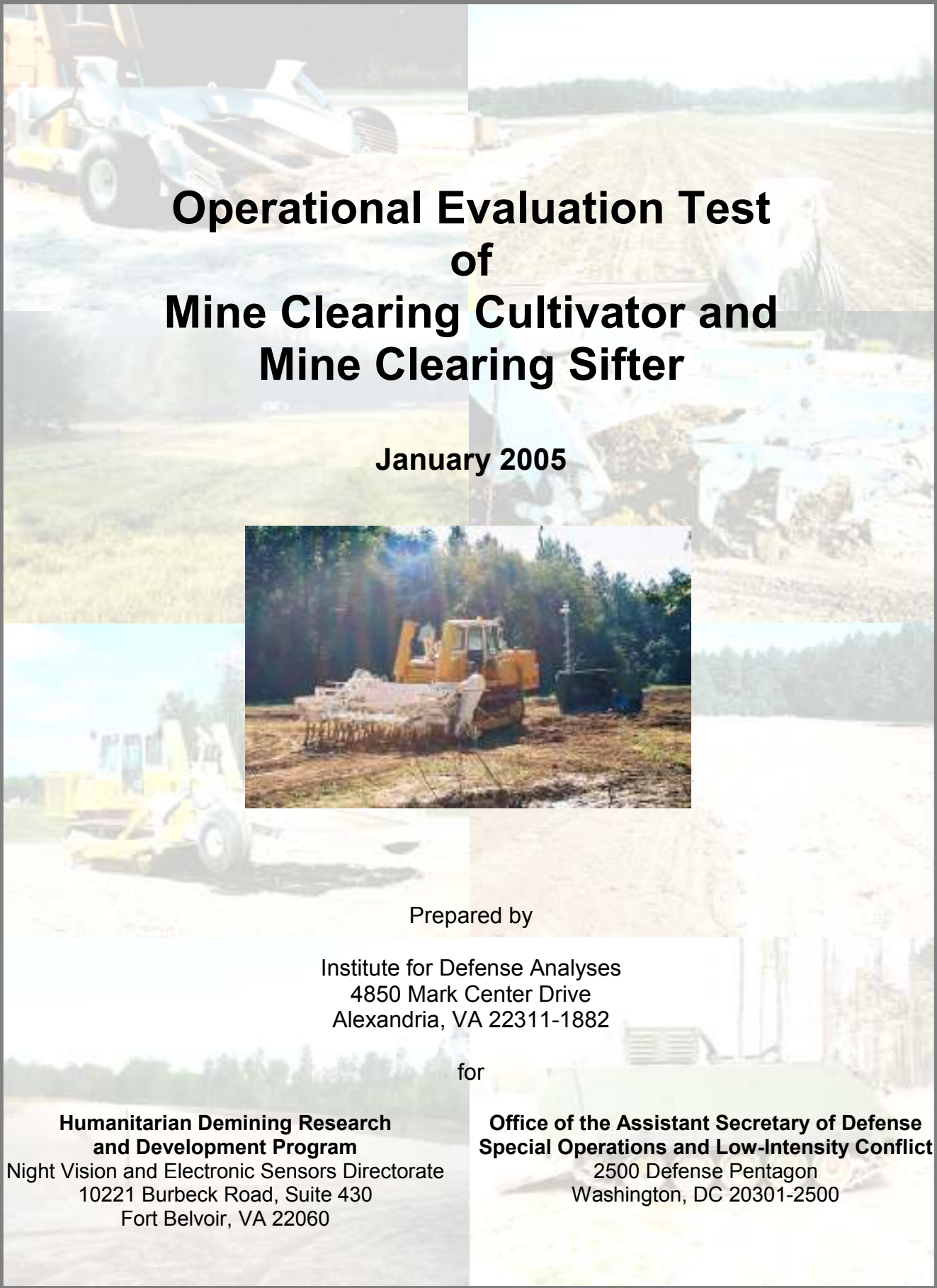

Operational Evaluation Test of Mine Clearing Cultivator and Mine Clearing Sifter

January 2005



Prepared by

Institute for Defense Analyses
4850 Mark Center Drive
Alexandria, VA 22311-1882

for

**Humanitarian Demining Research
and Development Program**
Night Vision and Electronic Sensors Directorate
10221 Burbeck Road, Suite 430
Fort Belvoir, VA 22060

**Office of the Assistant Secretary of Defense
Special Operations and Low-Intensity Conflict**
2500 Defense Pentagon
Washington, DC 20301-2500

**Operational Evaluation Test
of
Mine Clearing Cultivator and
Mine Clearing Sifter**

January 2005

FOREWORD

The successful completion of the Mine Clearing Cultivator and Mine Clearing Sifter (MCC/MCS) test program was due to the dedication of the test team assembled for this project. The test was conducted at a U.S. Army developmental test site in Virginia under the auspices of the U.S. Army's Research, Development, and Engineering Command; Communications-Electronics Research, Development and Engineering Center; Night Vision and Electronic Sensors Directorate; Countermine Division; Humanitarian Demining Branch (RDECOM-CERDEC-NVESD-HD).

From the onset of the test in the spring of 2003, the test program was repeatedly interrupted and delayed by one of the rainiest years on record. The result was a test program that took six months to complete, and, unfortunately, resulted in some test phases being abbreviated due to soil moisture conditions. Additionally, due to other intervening test programs, some system's technical data required for the report was not made available until later in 2004.

Special acknowledgments are due the efforts of Mr. Gregory Bullock, the Test Director, and Major Sewaphorn Rovira, USA, the Test Engineer, who managed to schedule test range availability on short notice between heavy bouts of rain. The Project Engineer, Mr. J. Michael Collins, designed and directed the fabrication of the Mine Clearing Cultivator (MCC) as well as the modifications to the Liebherr tractor and the Mine Clearing Sifter (MCS). The system operator, Mr. Ronald Collins, with many years of experience operating farming and earth moving equipment, was able to advise the test team on the effects of soil moisture content on operation of the cultivator and sifter. Mr. Robert Sellmer operated the remote camera video system.

The pre- and post-test locations of the test targets, and dimensional control of the test lanes and minefields were recorded using the Vulcan Laser Positioning System operated by Messrs. Richard Walls and Nathan Burkholder, Major Rovira, and Ms. Lawna Mathie. Test site preparation, burying of mines, and setting of mine smoke fuses was done by Messrs. Arthur Limerick, Harold Carr, and Mel Soult, all members of the development test site staff. Messrs. Harold Bertrand and Isaac Chappell, Mrs. Sherryl Zounes, and Ms. Emily Pryputniewicz of the Institute for Defense Analyses (IDA) recorded test data. The IDA staff cited above, with assistance from Major Rovira, wrote this report.

CONTENTS

1	Introduction	1
1.1	Background.....	1
1.2	Objective.....	1
2	System Description	1
2.1	General	1
2.2	Liebherr Tractor Crawler.....	2
2.3	Mine Clearing Cultivator (MCC).....	4
2.4	Mine Clearing Sifter (MCS).....	6
2.5	Standardized Remote Control System (SRCS)	7
2.6	Hydraulic Power Unit (HPU).....	8
2.7	Remote Command Vehicle (RCV) (Including the generator).....	9
3	Test Description, Procedures, and Results.....	9
3.1	Test Sites and Testing Equipment	9
3.1.1	Test Environment	12
3.1.2	Test Targets and Layout	13
3.1.3	Vulcan Laser Positioning System.....	14
3.2	Standardized Tests and Results	14
3.2.1	Standardized Test Sites and Layout	14
3.2.2	MCC Configuration for Standardized Tests.....	15
3.2.3	Standardized Test Procedure	16
3.2.4	Standardized Test Data Results and Observations	17
3.3	Operational Testing and Results.....	22
3.3.1	Operational Test Sites and Minefield Layout.....	22
3.3.2	Operational Test Procedure	25
3.3.3	Operational Test Results from Individual Test Sites.....	25
3.3.4	Operational Test Results Summary	31
3.4	Test Data Analyses	33
3.4.1	Data Collection.....	33
3.5	Human Factors Assessment.....	34
3.5.1	Operator Visibility and Fatigue	34
3.6	Logistics	35
3.6.1	Transportability	35
3.6.2	Turning Radius	35
3.6.3	Mobility	35
3.6.4	Routine Servicing and Maintenance.....	36
3.6.5	Consumables.....	36

3.7	Maintenance/Modification Issues.....	36
3.7.1	Unscheduled Maintenance Incidents During Testing	36
3.7.2	System Change-Out.....	37
3.7.3	Auger Fingers Change-Out	37
4	Test Summary Assessment	38
4.1	Mine Clearing Cultivator	38
4.2	Mine Clearing Sifter	38
4.3	Standardized Remote Control System (SRCR).....	38
4.4	Hydraulic Power Unit.....	39
5	Recommendations	39
6	Conclusions	40
	Glossary	GL-1
	Appendices	
	Appendix A— Heartlands Sifter	A-1
	Appendix B—Vulcan Laser Positioning System.....	B-1
	Appendix C—Raw Data (published as a separate document)	C-1

FIGURES

Figure 1: MCC/MCS and Control Vehicle	2
Figure 2: Liebherr Tractor with Modifications	3
Figure 3: Diagram of Liebherr Tractor Dimensions	3
Figure 4: Mine Clearing Cultivator.....	4
Figure 5: MCC Tines (A) and Auger (B) (shown with straight fingers)	5
Figure 6: MCC Auger Fingers: Straight (A) and Twisted (B).....	5
Figure 7: Depth Sensors.....	6
Figure 8: Mine Clearing Sifter.....	6
Figure 9: Modifications Made to the MCS	7
Figure 10: Components of the Standardized Remote Control System (SRCS).....	8
Figure 11: Hydraulic Power Unit (HPU).....	8
Figure 12: Remote Command Vehicle (exterior and interior).....	9
Figure 13: Test Site 1 – Sandy Loam with Sod	10
Figure 14: Test Site 1 – Sandy Loam without Sod	10
Figure 15: Test Site 2 – Sandy Clay.....	11
Figure 16: Test Site 3 – Sand.....	11
Figure 17: A Laser Transmitter and a Receiver Pole.....	14
Figure 18: Standardized Test Layout.....	15
Figure 19: Raking of Sand at Test Site 3	16
Figure 20: Minefield Layout at Test Sites 1 and 2.....	23
Figure 21: MCC/S Test Area Including Minefield and VLPS Layout	24
Figure 22: Sod Build-up In Front and Within the Cultivator’s Tines.....	26
Figure 23: Cracks Found on the MCC.....	36
Figure 24: Loose MCS Belt Repair.....	37
Figure 25: Mine Caught Under Center Bar.....	40

TABLES

Table 1: MCC/MCS Major Components' Weights and Dimensions.....	2
Table 2: Liebherr Tractor Dimensions.....	4
Table 3: Test Variables and Tests Performed	12
Table 4: Number of Tests Performed.....	12
Table 5: Targets Required for the Test Program.....	13
Table 6: Processing Results of the Standardized Tests.....	20
Table 7: Processing Distances (in meters) of the Standardized Tests.....	21
Table 8: Test Site 1 (Sandy Loam) Minefield Test – Processing Results.....	27
Table 9: Test Site 1 (Sandy Loam) Minefield Test – Processing Distances (meters).....	28
Table 10: Test Site 2 (Sandy Clay) Minefield Test – Processing Results	29
Table 11: Test Site 2 (Sandy Clay) Minefield Test – Processing Distances (meters)	29
Table 12: Test Site 3 (Sand) Minefield Test – Processing Results.....	30
Table 13: Test Site 3 (Sand) Minefield Test – Processing Distances, MCS Only (meters)	31
Table 14: Time to Cultivate and Sift.....	31
Table 15: Targets Processed and Missed by MCC/MCS.....	32
Table 16: Processing Distance & Damage of Targets through Test Cycle.....	32
Table 17: Results of the MCC Standardized Tests	33
Table 18: Turning Radius	35

1 INTRODUCTION

1.1 Background

As the result of field experience gained in Egypt and Angola, the Humanitarian Demining Program Management Office (HDPMO) of the U.S. Army Research, Development and Engineering Command (RDECOM), Communications-Electronics Research, Development and Engineering Center (CERDEC), Night Vision and Electronic Sensors Directorate (NVESD) undertook the design and fabrication of a heavy-soil cultivator to lift buried antitank (AT) and antipersonnel (AP) mines to the surface and move them off to the side in windrows. This unit was designated the Mine Clearing Cultivator (MCC). In addition, in 2002, the HDPMO also tested the ability of a modified agricultural sifter to remove mines from moderately loose, sandy soil, separate the mines from the soil, and accumulate the mines to one side of the track being cleared. It was thought that by combining the two pieces of equipment in a toolkit fashion, the cultivator and the sifter, that 100% of the mines in an area could be recovered.

1.2 Objective

The objective of this test program is to determine the ability of the Mine Clearing Cultivator and Mine Clearing Sifter (MCC/MCS) to clear a minefield by bringing buried AT and AP mines to the surface and accumulating the mines in windrows to both the left and right of the cultivator. The mines remaining in the cultivated soil but not visible to test observers or equipment operators, as well as mines buried in the windrows, will be removed by the soil sifter. While the sifter can be configured to deposit mines to either the left or right, for this test, the sifter was configured to deposit mines to the left. The transportability and mobility of the system for logistical purposes and human factors issues (e.g., camera visibility and operator training) were examined. Maintenance and equipment factors (e.g., fuel/oil consumption and implement changing time) were recorded.

2 SYSTEM DESCRIPTION

2.1 General

The Mine Clearing Cultivator/Mine Clearing Sifter (MCC/MCS) consists of the following: the prime mover, the cultivator, the sifter, the Standardized Remote Control System (SRCS) and a hydraulic power unit (HPU). The prime mover for both the cultivator and the sifter is a Liebherr Crawler Tractor, Model No. PR742B, with a rear-mounted HPU. The HPU supplies power to both the cultivator and the sifter. The Mine Clearing Cultivator was designed and built by the Modeling and Mechanical Fabrication Shop of NVESD at Ft. Belvoir, Virginia, as was the Standardized Remote Control System for remote operation of the prime mover, cultivator and sifter. Support equipment includes a separate vehicle to house the remote operators' control station and a portable generator unit. The Reliance Corporation built the sifter.



Figure 1: MCC/MCS and Control Vehicle

The weights and dimensions of each of the major components of the MCC/MCS are presented in Table 1. All weights are actual weights (not manufacturer supplied weights) of the systems used during the test including all operating fluids. All dimensions reflect modifications made to commercial off-the-shelf (COTS) systems.

Table 1: MCC/MCS Major Components' Weights and Dimensions

MCC/Sifter Component	Weight lb. (kg)	Length ft. (meters)	Width ft. (meters)	Height ft. (meters)
Liebherr Tractor	50,595 (22,950)	14' 2.75" (4.34)	9' 8" (2.95)	10' 9" (3.28)
Mine Clearing Cultivator	14,700 (6,670)	12' 3" (3.73)	12' 3" / 16' 5" (3.73 / 5.00) [†]	5' 7" (1.70)
Mine Clearing Sifter	2,800 (1,270)	13' 6" (4.11)	15' 5.25" (4.71)	5' 8" (1.73)
Hydraulic Power Unit	4,580 (2,077)	4' 3.25" (1.30)	8' (2.44)	4' 7" (1.40)
Remote Command Vehicle	23,980 (10,900)	15.94 (4.86)	9.38 (2.68)	9.0 / 8.5 (2.74 / 2.59) [‡]

[†] 1st number is drive train chamber width, 2nd is auger tip to auger tip.

[‡] With and without camera mast mounted.

2.2 Liebherr Tractor Crawler

The prime mover for the MCC/MCS is a Liebherr Crawler Tractor, Model PR742B Litronic, manufactured by Liebherr-Werk-Telfs GmbH, Telft, Austria. The Liebherr has a hydrostatic transmission system, which allows continuous and total control of the power to the tracks. This feature gives the operator the ability to adjust the power setting necessary to maintain a set speed for the prime mover as resistance to forward movement varies, a desired capability when operating the MCC/MCS.

In order to meet the hydraulic requirements of the cultivator and sifter, a hydraulic power unit (HPU) was added (see Section 2.6 below). Finally, the SRCS was added to

allow driving of the tractor and operation of the MCC and MCS from a remote command vehicle.



Figure 2: Liebherr Tractor with Modifications

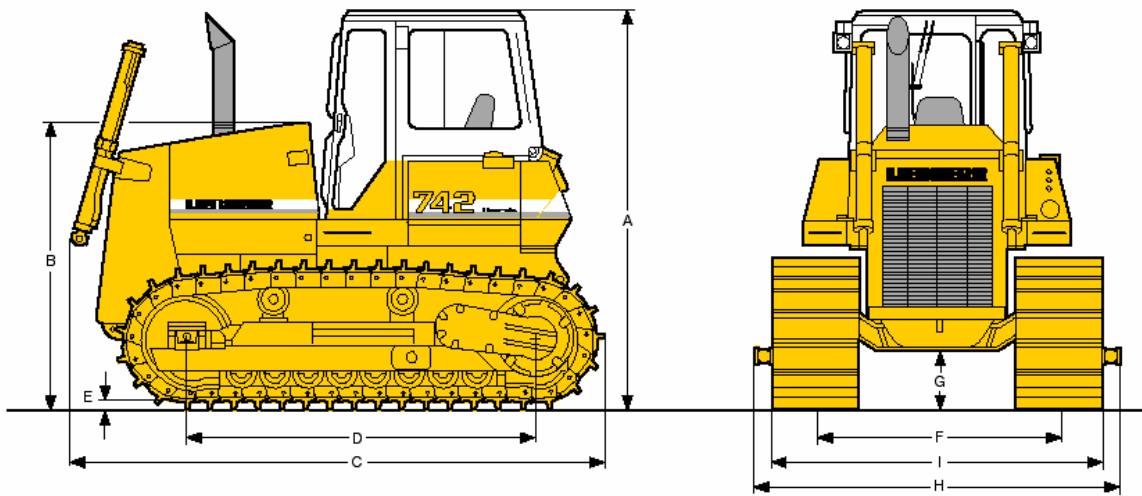

Figure 3: Diagram of Liebherr Tractor Dimensions*

* Diagram Source: Liebherr's technical brochure *TB PR 722 B Litronic*

Table 2: Liebherr Tractor Dimensions

DIMENSIONS		FEET	METERS
A	Height to Top of Tractor	10.8	3.30
B	Height to Top of Engine Cowling	7.8	2.38
C	Length	14.1	4.30
D	Distance Between Axles	9.7	2.96
E	Track Tread Depth	0.024	0.07
F	Track Width	3.3	1.98
G	Clearance	1.6	0.48
H	Overall Width	9.8	2.97
I	Outside Track Width	8.8	2.68

2.3 Mine Clearing Cultivator (MCC)

The MCC was designed and built by the Modeling and Mechanical Fabrication Shop of the Night Vision and Electronic Sensors Directorate (NVESD), Ft. Belvoir, Virginia. The cultivator tines are designed to break up the soil and bring dislodged mines to the surface. The spacing of the cultivator tines allows a mine to move through the cultivator to a horizontal auger whose purpose is to move the mines out of the cultivator and deposit the mines in a berm to either the left or right of the cultivator and tractor.



Figure 4: Mine Clearing Cultivator

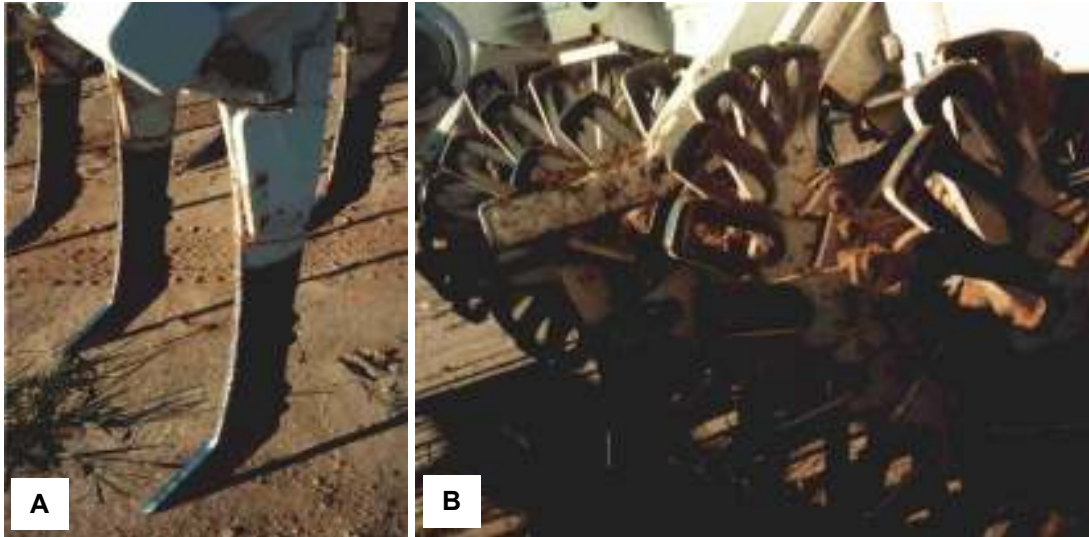

Figure 5: MCC Tines (A) and Auger (B) (shown with straight fingers)

Two auger finger designs, straight and twisted, were tested to determine which design most efficiently moved surfaced mines out of the cultivator for different types of soil. During minefield tests in sandy loam and sandy clay soils, straight fingers were used very effectively. However, this was not the case in cultivating the minefield in sand. The twisted auger fingers proved to be more effective in sand. The reasons for this are discussed later in the report.

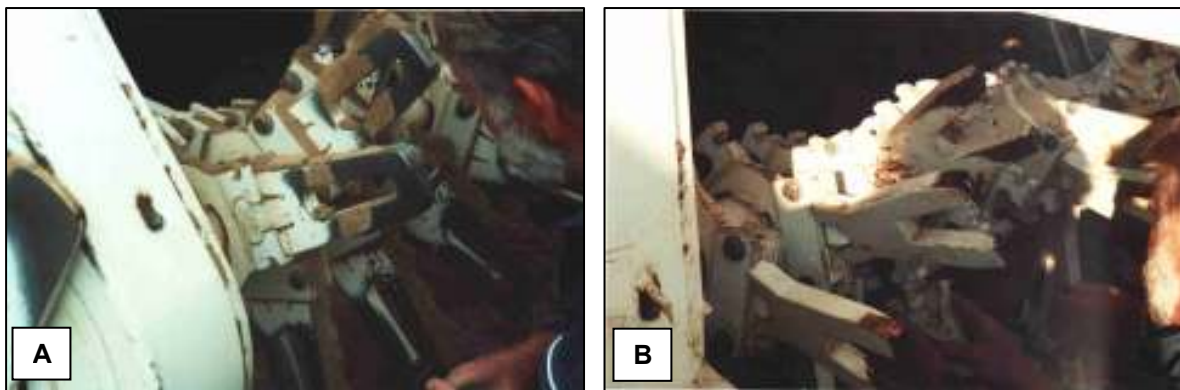

Figure 6: MCC Auger Fingers: Straight (A) and Twisted (B)

Figure 7 shows the depth sensors mounted on the front edge of the cultivator. Their purpose is to automatically control the operating depth of the cultivator tines by maintaining a constant distance above the ground.



Figure 7: Depth Sensors

2.4 Mine Clearing Sifter (MCS)

The Mine Clearing Sifter (MCS), manufactured by the Reliance Corporation, is identical to the Heartlands Sifter tested by NVESD in 2002. (The report on the 2002 test of the Sifter is presented in Appendix A). The sifter, an off-the-shelf agricultural machine, is used to remove land mines from the soil by the sifting action of two steel-bar conveyor belts and a discharge conveyor belt that deposits the mines in windrows off to the side of the sifter and prime mover. The discharge belt drive mechanism allows selecting the side of discharge.



Figure 8: Mine Clearing Sifter

After testing the MCS in 2002, a number of improvements (see Figure 9) were made based on observations during the test. The front of the fore-aft center support beam

(A) was tapered to fare into the nose scoop due to a couple of mines becoming stuck against the blunt end of the support beam. The cutout (B) in the center beam over the rear conveyor belt was raised to allow AT mines to pass under the center beam on the discharge belt. Side bars (C) were added at the front of the sifter to prevent mines from going over the side with excess dirt spillage before reaching the sifting conveyor belt. To prevent small AP mines from falling to the ground beneath the sifter, a rubber guard (D) was added below the primary conveyor belt to close a gap between the primary sifting belts and the discharge conveyor belt. Finally, a short, wire chute (E) was added to the end of the discharge chute to insure that mines leaving the sifter were deposited outboard of the prime mover's tracks.

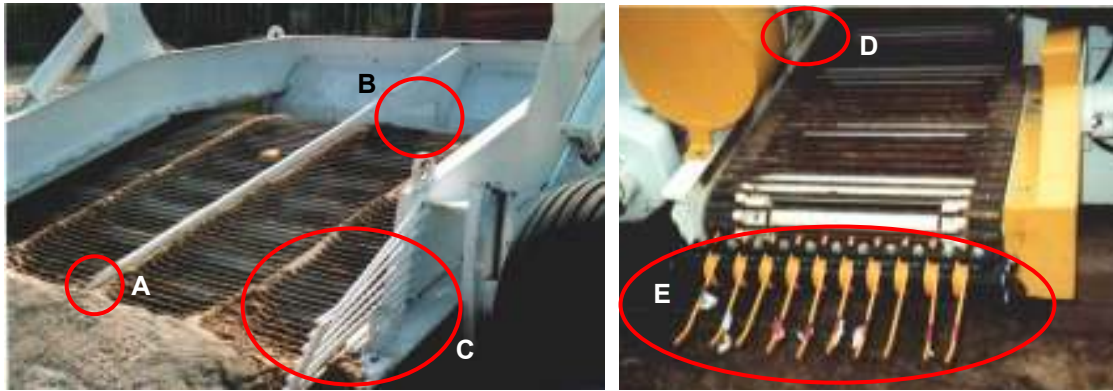
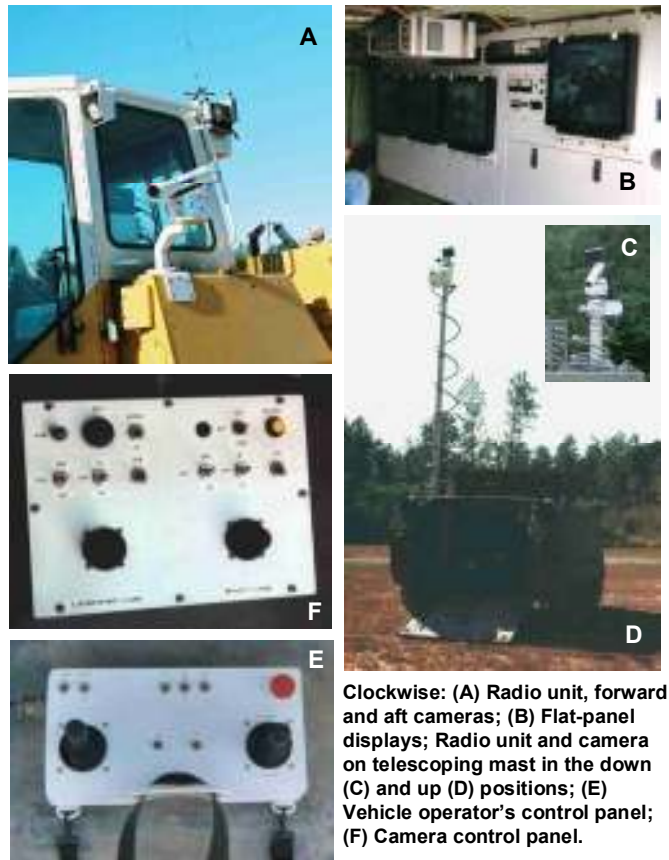

Figure 9: Modifications Made to the MCS

(A) Support Beam Faring , (B) Increased Clearance, (C) Side Bars, (D) Rubber Guard, (E) Discharge Chute

2.5 Standardized Remote Control System (SRCS)

The SRCS, designed and fabricated by the Modeling and Mechanical Fabrication Shop at Ft. Belvoir, is intended for use in any vehicle used in a humanitarian demining mission requiring remote operator control for reasons of safety. The SRCS was designed to be mounted in any vehicle large enough to accommodate the operators' station and up to five flat-panel displays. The SRCS is a line-of-sight system that operates at a frequency of 900 MHz, has 32 analog and 64 digital processors allowing control of 96 separate functions, and has a range of 3 km. The SRCS consists of two transmitter/receiver radio units, four remotely controlled (moveable) cameras (three looking forward, one looking aft) mounted on the prime mover, a remotely controlled telescopic mast-mounted camera mounted on (or erected at) the command center for viewing the working demining system, four flat-panel displays (one for each camera), a vehicle operator's control panel, a camera control panel, and a portable Honda 5000 generator. A 5th flat panel display was used to show a composite of the 4 camera displays.



Clockwise: (A) Radio unit, forward and aft cameras; (B) Flat-panel displays; Radio unit and camera on telescoping mast in the down (C) and up (D) positions; (E) Vehicle operator's control panel; (F) Camera control panel.

Figure 10: Components of the Standardized Remote Control System (SRCS)

2.6 Hydraulic Power Unit (HPU)

Due to the hydraulic power requirements of the cultivator and sifter, an auxiliary, diesel-driven HPU was mounted just aft of the cab on the Liebherr crawler tractor. The HPU, powered by a 177 HP, Deutz diesel engine, is capable of providing 80 gpm of hydraulic fluid at a pressure of 3000 psi.



Figure 11: Hydraulic Power Unit (HPU)

2.7 Remote Command Vehicle (RCV) (Including the generator)

The SRCS is a stand-alone system that can be mounted in any van-like vehicle (or large SUV) or a small portable room. The volume needed must accommodate the vehicle and mast-mounted camera operators and have wall space for five flat-panel displays measuring 18×24 inches each. For this test, an M113 armored personnel carrier was used as the Remote Command Vehicle (RCV). In other tests using the SRCS, SUV-like vehicles have been used as the RCV. The portable generator for the SRCS and a commercial air conditioner were mounted on the roof of the M113.



Figure 12: Remote Command Vehicle (exterior and interior)

3 TEST DESCRIPTION, PROCEDURES, AND RESULTS

3.1 Test Sites and Testing Equipment

Three test sites at an NVESD developmental test center were used to allow testing in three different soils and two variations of vegetation cover. The test sites were designated as Test Sites 1, 2, and 3 to correspond to the order in which they were used during the test program. Test Site 1 consisted of sandy loam soil with heavy field grass coverage. Test Site 2 was sandy clay soil with very sparse clumps of field grass. Test Site 3 was a sand area with no vegetation. Test Sites 1 and 2 were large areas allowing separate areas for both a standardized test site and a minefield site. The sand test area, Test Site 3, was not as large and required the reuse of the smaller area for both the standardized test and the minefield test.



Figure 13: Test Site 1 – Sandy Loam with Sod



Figure 14: Test Site 1 – Sandy Loam without Sod



Figure 15: Test Site 2 – Sandy Clay



Figure 16: Test Site 3 – Sand

3.1.1 Test Environment

The MCC/MCS was tested under the following environmental conditions: Test Site 1, sandy loam soil, heavy field grass (sod); Test Site 1, sandy loam soil, no sod; Test Site 2, sandy clay soil, no sod; Test Site 3, sand, no sod. Test site configurations for Sites 1 and 2 were identical (see Figure 18 and Figure 20). The sand soil tests at Site 3 were conducted in an area measuring 302 ft (92.0 m) long, 76 ft (23.2 m) wide, and 24 inches (0.61 m) deep. Area restrictions of Site 3 required that the standardized and minefield tests be run as single lane tests, with mines being reburied after each lane-clearing until the specified number of mines for each test had been tested against the MCC.

Table 3: Test Variables and Tests Performed

Location	SITE 1		SITE 2	SITE 3	
Soil Type	Sandy Loam		Sandy Clay	Course Sand	
Soil Surface	Sod	No Sod	No Sod	No Sod	
MCC Auger Tine Type	Straight	Straight	Straight	Straight	Twisted
SINGLE LANE STANDARDIZED					
MCC	Yes	Yes	Yes	Yes	Yes
MCS	No	No	No	No	No
MINEFIELD					
MCC	Yes	Yes	Yes	No	Yes
MCS	No	Yes	Yes	No	No

Table 4: Number of Tests Performed

Location	Number of Standardized Tests	Number of Minefield Tests
Site 1 – Sandy Loam with Sod	3	1
Site 1 – Sandy Loam without Sod	3	1
Site 2 – Sandy Clay	3	1
Site 3 – Sand	3	1*

*Minefield test comprised of repetitive replanting of mines in a smaller area.

3.1.2 Test Targets and Layout

The number of targets required for the three test areas are shown in Table 5. Standardized tests were conducted in each soil type (sandy loam, sandy clay, sand) utilizing 12 round, metal AT mines (AT-r/m) buried four each in three lanes. All AT-r/m mines contained smoke fuses. For the operational testing at Test Sites 1 and 2, minefields contained 50 mine clusters based on NATO minefield doctrine of one AT mine and two AP mines (total 150 mines for each minefield). Trials at Test Site 3 were also conducted using 50 AT mines but without the AP-mine pairing.

Table 5: Targets Required for the Test Program

	SITE 1: SANDY LOAM			SITE 2: SANDY CLAY		SITE 3: SAND		Total
	Sod	No Sod		No Sod		No Sod		
	Standard	Standard	Minefield	Standard	Minefield	Standard	Minefield	
AT MINES								
AT-r/m	12	12	31	12	34	12	34	147
AT-s/p			6		6		6	18
TM46			3					3
TM62			7		7		7	21
VS1.6			3		3		3	9
Total	12	12	50	12	50	12	50	198
AP MINES								
Type 72			26		26			52
PMA1			23		23			46
PMA2			24		24			48
PMN			27		27			54
Total			100		100			200

Note: "Standard" heading refers to the standardized test layout.

3.1.3 Vulcan Laser Positioning System

The Vulcan Laser Positioning System (VLPS), a COTS survey marking system manufactured by the Arc Second, Inc., in Dulles, Virginia, was used during testing to measure initial and final positions of the test targets. The VLPS allows very accurate and precise measurements in three axes by use of local positioning transmitters. A basic system consists of two laser transmitters that are set up in fixed positions and a receiver pole that can be placed anywhere in the range of the transmitters. More details on the VLPS are presented in Appendix B.

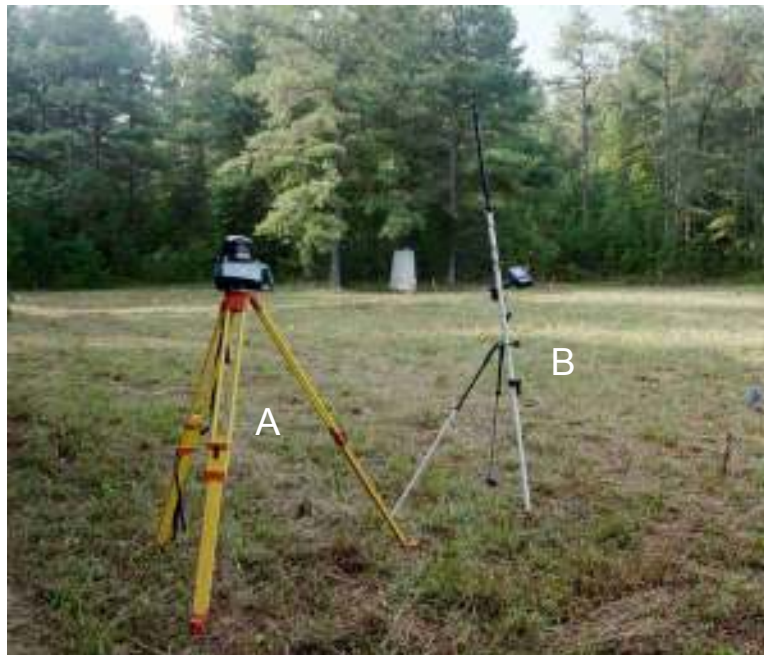

Figure 17: A Laser Transmitter (A) and a Receiver Pole (B)

3.2 Standardized Tests and Results

3.2.1 Standardized Test Sites and Layout

A standardized test was designed and conducted in each of the different soil conditions: sandy loam with and without sod, sandy clay, and sand. Since Site 1 was the only site that had complete sod coverage, it was the only site where tests were run under both a sod, and no sod condition. The purpose of the test was to determine the distance the MCC required to clear a mine from initial target position through discharge by the auger. This information will be used to recommend a minimum cultivating distance beyond the edge of a minefield that the MCC should operate to minimize the possibility of mines being trapped in the working area of the cultivator or in the end berm created by the cultivator.

For Sites 1 and 2, the standardized test was conducted in an area that was 20 meters wide (three 6-meter-wide lanes with one-meter separation between the lanes) and 65 meters in length. Four AT mines with smoke fuses were buried in the center of each lane, with a 15-meter separation between each mine, starting at one meter (see Figure 18). Each mine was buried at a depth of 4 inches (10 cm) measured to the top of the mine. The purpose of having the cultivator engage the mines close to the cultivator's centerline was to maximize the distance a mine would have to travel inside of the cultivator until it was discharged by the auger.

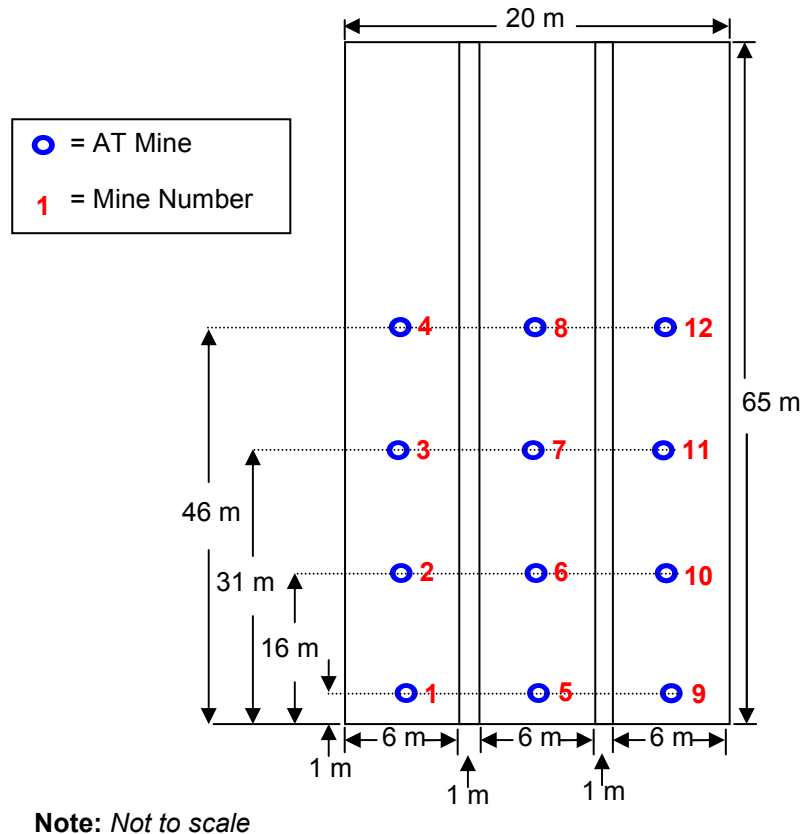

Figure 18: Standardized Test Layout

For Site 3, the sand soil test, one lane, 6 meters wide and 65 meters long, was used for three successive runs.

3.2.2 MCC Configuration for Standardized Tests

Two MCC auger configurations were used during the standardized tests. At Test Sites 1 and 2, in heavier soils with some moisture retention, the auger was used with straight fingers. At Test Site 3, the auger was used with twisted fingers. The reason for this configuration change is as follows. In heavier soils (other than predominately sand soils), sufficient amounts of soil are pushed forward of the auger thereby causing the soil to flow toward the discharge end of the auger. The movement of the soil influences the

direction in which mines reaching the auger tend to move. In sand, however, the straight fingers tend to cut through the sand as a knife would through water, thereby not causing the sand to flow in an outward direction. As a result, it was found that mines, which were normally moved by one finger at a time, would bounce along in a straight line in front of the auger, and without the added influence of outward flowing soil, would stay in the auger's working area. This situation was corrected by replacing the straight fingers with twisted fingers, which started the sand in front of the auger to flow in an outward direction. This, in turn, influenced the outward movement of the mines (see Figure 6 on page 5).

3.2.3 Standardized Test Procedure

Prior to the start of each test, the location of each mine (x, y, and z coordinates) was recorded and stored in the VLPS. Cultivation with the MCC started 15 meters before the start of the test lanes, allowing the cultivator operator sufficient distance to position the cultivator tines at the appropriate operating depth, to adjust the camera apertures to allow for ambient lighting, and to insure proper alignment with the center of the lane. As each mine was brought to the surface by the MCC, note was made of whether it was seen by both the system operator and ground observers. The MCC proceeded to the end of each lane, at which time the cultivator was extracted from the soil. The final location of each mine was measured with the VLPS, exposed mines were removed from the test lane, and the MCC prime mover was backed up to its starting point. At Test Site 1, the procedure was conducted twice. The first time in uncut, sod-covered soil, the second time in soil stripped of sod that had been previously cultivated during the sod test. At Test Site 3, the three lanes of testing were conducted in a single lane that was raked (see Figure 19 below) and replanted with mines between each single-lane run.



Figure 19: Raking of Sand at Test Site 3

3.2.4 Standardized Test Data Results and Observations

The results presented address two test issues. Table 6, page 20, presents processing results, i.e., whether the cultivator processed surfaced mines through the cultivator and discharged them off to either side. Table 7, page 21, presents the minimum, maximum, and average distance that the cultivator had to travel from the point of a mine's burial to the point that the mine exited the cultivator.

3.2.4.1 Test Site 1: Sandy Loam

Soil at Site 1 was a sandy loam with full sod cover. The soil moisture content averaged 17.7% for the first day of the standardized test with the test lanes fully sod covered. During the second day of the standardized test, after all sod had been removed (explained below), the soil moisture content was 26.2%. High soil moisture and sod cover contributed to the difficulties experienced during the standardized test.

It was during this test that the problem with sod build-up in the cultivator was encountered. As the tines of the cultivator went through the soil, they picked up the grass including the topsoil and the root system underneath. In addition, the moist soil tended to clump and bind with the sod. This sod and soil build-up within the tines prevented the mines from passing between the tines and reaching the auger. At a couple of points during the test, the build-up became so great that the prime mover lost traction and could no longer make forward progress with the cultivator. The cultivator then had to be lifted out of the ground, sod and dirt removed from the tines, the tractor backed up at least 5 meters, and the cultivator reinserted into the soil to continue the operation. It was during the reinsertion of the cultivator into a lane that some mines were stabbed or activated. The sod build-up also resulted in a very large end-berm that had to be cleared of mines by hand after scanning with a metal detector.

According to the test plan, the cultivator was to make one pass down each of three standardized test lanes. After the first pass, due to problems associated with sod build-up, it was decided that two passes were needed. The first pass was to remove as much of the sod as possible without disturbing the buried mines. The second pass was to cultivate the soil to the depth necessary to reach the buried mines. This would not be done operationally as it puts the equipment at risk of running over a mine. Even after completing two passes, the cultivator processed only 10 of the 12 mines. Four of the 10 processed mines showed signs of either being stabbed by one of the cultivator tines or of being busted open by impacts from the cultivator. When the remaining mines were found by use of a metal detector after the test, one was found to have been stabbed by the cultivator. Smoke fuses were activated on two of the 10 processed mines.

Based upon the results of the test in soil with sod cover, a decision was made to run the test again in the same soil but without sod cover. The test site was stripped of sod using the MCC and the mines replanted. The standardized test was repeated with the cultivator uncovering all 12 mines and processing them through the cultivator within the length of the test lane.

Results for all standardized tests are shown in Tables 6 and 7. Comparing the results of the two tests at Test Site 1 is a little difficult. Given the width of the cultivator, one would expect the cross-track (x-axis) processing distance of mines by the cultivator to be something greater than two meters. Without the sod, the average distance was about two meters. With-sod processing distances were substantially less than one meter. This discrepancy would indicate that the cultivator was off-center of the lane. In fact, this did occur repeatedly as a result of the sod build-up in the cultivator obscuring the operator's ground reference line (see Figure 22 on page 26). Cross-track movement of test targets by the cultivator showed less distance moved when sod was present than without sod.

The down-track (y-axis) processing distance averaged about 24 meters for the sod test and 20 meters for the no-sod test conditions. These results were expected since it was easy to see that the build-up of sod on the cultivator tines impeded the movement of the mines through the cultivator. In the sod test condition, the maximum distance that a mine was carried was over 63 meters with the mine being found in the end-berm. In the no-sod test condition, the maximum distance was 36 meters.

3.2.4.2 Test Site 2: Sandy Clay

The tests at Test Site 2 yielded results close to what the test team anticipated beforehand. First, with no sod cover, the cultivator processed 11 of the 12 test targets. The 12th target was stabbed and carried a distance of 51 meters. Average cross-lane distance (x-axis) was about half the width of the cultivator, whereas the down-lane distance (y-axis) was 24 meters (21.7 meters if stabbed mine is dropped from average). The down-lane processing distance was greater in the sandy clay soil than the sandy loam soil due to the one stabbed mine being carried to the end of the test run.

3.2.4.3 Test Site 3: Sand

Similar to the tests at Sites 1 and 2, the MCC was tested at Site 3 with the straight-fingers auger configuration. This trial was aborted because the berm created in front of the auger was not large enough to create the effect necessary to move the sand outward. Instead, the mines were pushed in front of the auger and never moved outside the vehicle lane (See Section 3.2.2). The test was rerun with the twisted-finger auger configuration.

The sand test, with the twisted-finger auger configuration, yielded excellent results. All 12 mines were lifted and processed, no smoke fuses were activated, and no mines were stabbed or damaged. Cross-track processing distance averaged 1.5 meters. The down-track processing distance was 18.7 meters. There was, however, one incidence of a mine being caught under a structural bar of the cultivator's frame and being moved in front of the auger for an extended distance before being processed out of the cultivator.

3.2.4.4 Standardized Tests Summary

The results of the standardized tests varied significantly between Site 1 and the other two test sites. Table 6 presents data on the number of mines processed, Table 7 gives down- and cross-track distances that mines were moved from their original location while being processed by the MCC. At Site 1, once it became obvious that the heavy sod was going to cause havoc with the test procedure, the test was temporarily halted until the surface sod could be removed. It was prior to the sod being removed that some of the mines were either damaged (dented, broken) or stabbed by the cultivator tines. The reason is as follows. All test targets were buried at a depth of 4 inches (10 cm) measured to the top of the mine. Site 1 was a grassy, open field whose surface was quite uneven. While the maximum working depth of the cultivator's tines was 12–15 inches (30–38 cm), the unevenness of the ground prevented the operator from maintaining a constant working depth and either the front or trailing row of cultivator tines came out of the ground. This situation was more pronounced on the first Site 1 pass before the surface sod had been cut or stripped by the cultivator. Because of problems with sod and dirt build-up in the cultivator tines the test was stopped, mines were recovered, the sod removed from the area, and the mines reburied. Sites 2 and 3 were mostly level and free of sod, therefore, the cultivator depth was much easier to maintain, both by the depth control sensors and by the remote operator using the SRCS and cameras.

All mines used in the standardized tests had smoke fuses requiring pressures similar to live fuses to activate. Of the 36 mines used in the three Standardized Tests without sod, only two had their smoke fuses activated, and those two occurred at Site 1. This is a good indicator that the MCC, when operating in the right soil conditions and at the proper depth, would be very effective in safely lifting antitank mines and moving them to the side without causing a detonation.

Soil moisture readings for Site 1, after the sod was removed, averaged 26.2 %. This was slightly above our self-imposed limit of 25%, but due to schedule pressures, the test was conducted nevertheless.

Table 6: Processing Results of the Standardized Tests

Location	SITE 1		SITE 2	SITE 3
Soil Type	Sandy Loam		Sandy Clay	Sand
Soil Surface	Sod	No Sod	No Sod	No Sod
Soil Moisture	17.7%	26.2%	11-23%	0.9-1.6%
MCC Auger Fingers (Tine) Design	Straight	Straight	Straight	Twisted ¹
DAMAGED TARGETS				
Stabbed/Damaged ² (processed ³)	4	2	0	0
Stabbed/Damaged ² (not processed ⁴)	Test Halted	1	0	0
Activated ⁵	N/A	0	0	0
ACCOUNTING FOR TARGETS				
Total Test Targets ⁶	N/A	12	12	12
Processed/Exposed ⁷	N/A	12	12	12
Targets Missed ⁸	N/A	0	0	0

¹ Twisted auger fingers required in sand.

² Test targets stabbed or damaged including those severely dented or broken into parts.

³ Test targets (and/or parts of targets) that exited the cultivator from the left or right of the auger.

⁴ Test targets (and/or parts) that did not exit the cultivator as designed (e.g. stuck on tines, still in auger berm, passed under the auger, run over).

⁵ Smoke fuses activated during the test (one fuse per test target) simulating mine detonation.

⁶ Test targets in the ground at the start of the test.

⁷ Test targets that were either processed through the cultivator or visibly exposed by the actions of the cultivator.

⁸ Test targets not processed or exposed by the cultivator that had to be recovered after the test.

The reason for measuring the cross- and down-track mine displacement distance from its original location to the point of discharge from the cultivator was to provide insight into how far a mine might stay in the cultivator before being processed out when lifted by the MCC at the edge of a minefield as the MCC is exiting. This includes the linear distance a mine might be pushed underground while working its way to the surface or the distance it might roll in the cultivator's frontal berm before becoming visible. This information will alert MCC users to the necessity of processing end berms or to continue operation of the MCC beyond the mine infested area for a distance that insures all mines have surfaced.

A review of the data in Table 7 does not readily support operating the MCC beyond the exit edge of a suspected mined area for any significant distance (y-axis) to insure all mines have been processed. The spread in the y-axis distance a mine was carried varied from 0.56 meters to 63.9 meters. Our recommendation and procedure adopted during the test program was to proceed approximately three meters beyond the edge of the test area, stop forward movement, and raise the MCC out of the frontal berm. This berm can then be cleared by deminers using metal detectors or by means of sifting equipment such as the ROTAR.

Table 7: Processing Distances (in meters) of the Standardized Tests

Location	SITE 1		SITE 2	SITE 3
Soil Type	Sandy Loam		Sandy Clay	Sand
Soil Surface	Sod	No Sod	No Sod	No Sod
MCC Auger Tine Type	Straight	Straight	Straight	Twisted
CROSS-TRACK (X AXIS)				
Min. Processing Distance	0.073	0.167	0.423	0.511
Max. Processing Distance	2.347	5.117	2.475	2.716
Average Processing Distance	0.779	2.121	1.536	1.465
Median Processing Distance	0.445	2.198	1.553	1.239
Std. Dev. Processing Distance	0.786	1.509	0.667	0.833
DOWN-TRACK (Y AXIS)				
Min. Processing Distance	9.129	0.561	8.840	3.341
Max. Processing Distance	63.911	44.191	51.102	54.217
Average Processing Distance	23.941	20.165	24.183	18.743
Median Processing Distance	18.633	18.258	21.457	15.116
Std. Dev. Processing Distance	16.219	12.536	12.594	15.242

3.3 Operational Testing and Results

3.3.1 Operational Test Sites and Minefield Layout

Operational testing was conducted at the three test sites described in Section 3.1. For Test Sites 1 and 2, the minefield layouts were identical to that shown in Figure 20. The test target mix is presented in Section 3.1.2, Table 5 (on page 13). Each minefield had 50 mines clusters—one AT mine and two AP mines. Each AT mine was buried at a depth of 4 inches (10 cm) measured to the top of the mine. The AP mines were buried just below the surface. This provided a total of 150 test targets for each minefield. Due to a lack of test assets, the three TM46 mines used in the AT mine mix at Site 1 were replaced with three round, metal AT mines at Sites 2 and 3.

The test minefields at Sites 1 and 2, the areas in which the mines were buried, measured 20×140 meters. The test area used for the MCC measured 28×170 meters. This allowed 10 meters to stabilize the cultivator's depth before entering the mined area, and 20 meters beyond the mined area to insure that any mines still in the cultivator had a sufficient distance to be processed out of the cultivator. Four meters, the width of the cultivator, was cultivated on each side of the test area to allow transitioning into and out of the mined area. The overall layout of the test area is shown in

Figure 21 with the first and last 6 meters of the width of the test area showing the location of the VLPS transmitters and snap points (see Appendix B).

Due to the limitations of the size of the sand lane used for Test Site 3, 50 AT mines were buried in groups of 13, 13, 12, and 12, staggered in a lane 265 ft (~85 m) long. Replanting of the test lane was repeated three times for a total of four passes and 50 AT mines. AP mines were not buried since experience showed that they are best removed from sand using only the sifter.

The round, metal AT mines at all three test sites were buried with smoke fuses installed to simulate the detonation of an AT mine.

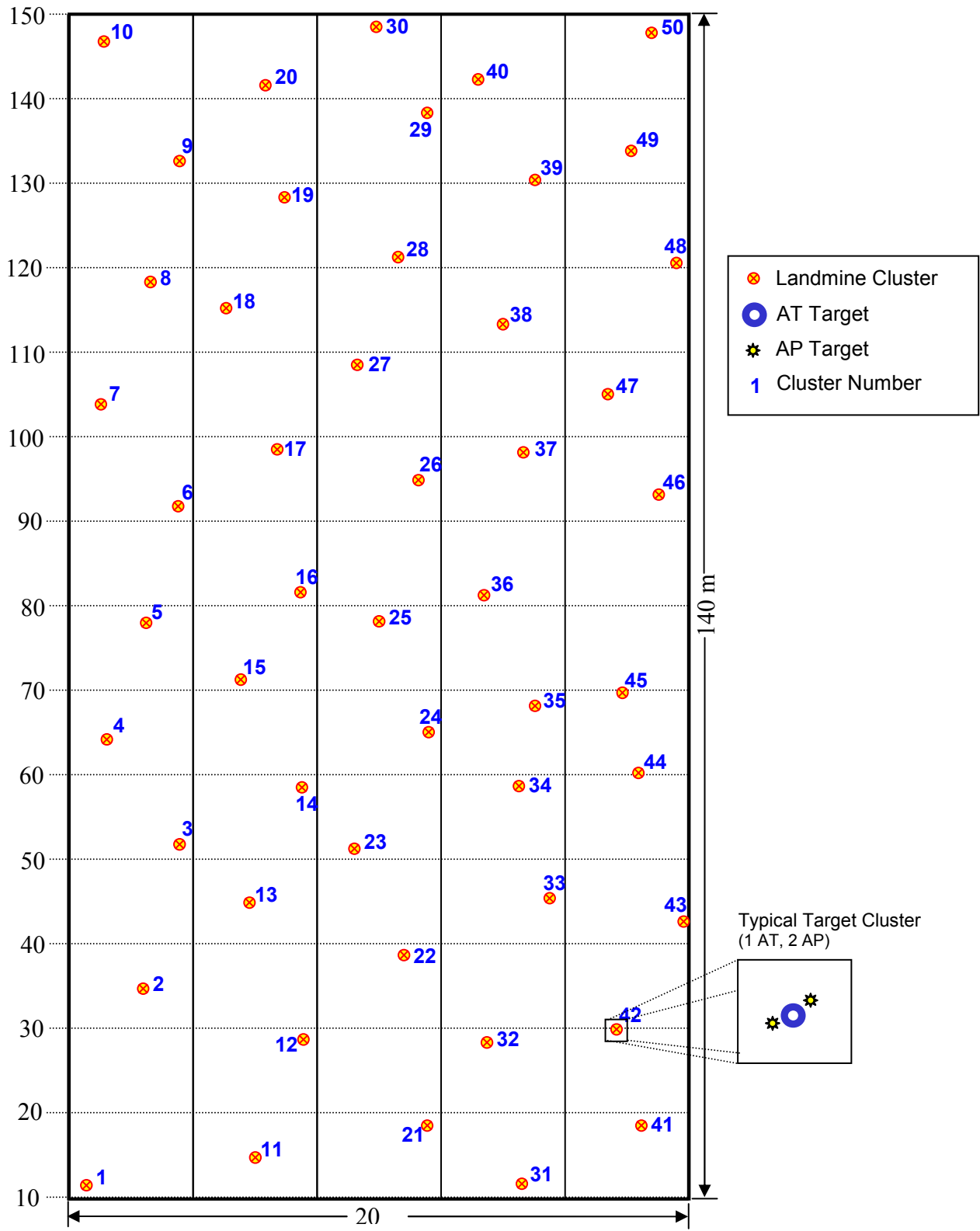

Note: Figure is not to scale

Figure 20: Minefield Layout at Test Sites 1 and 2

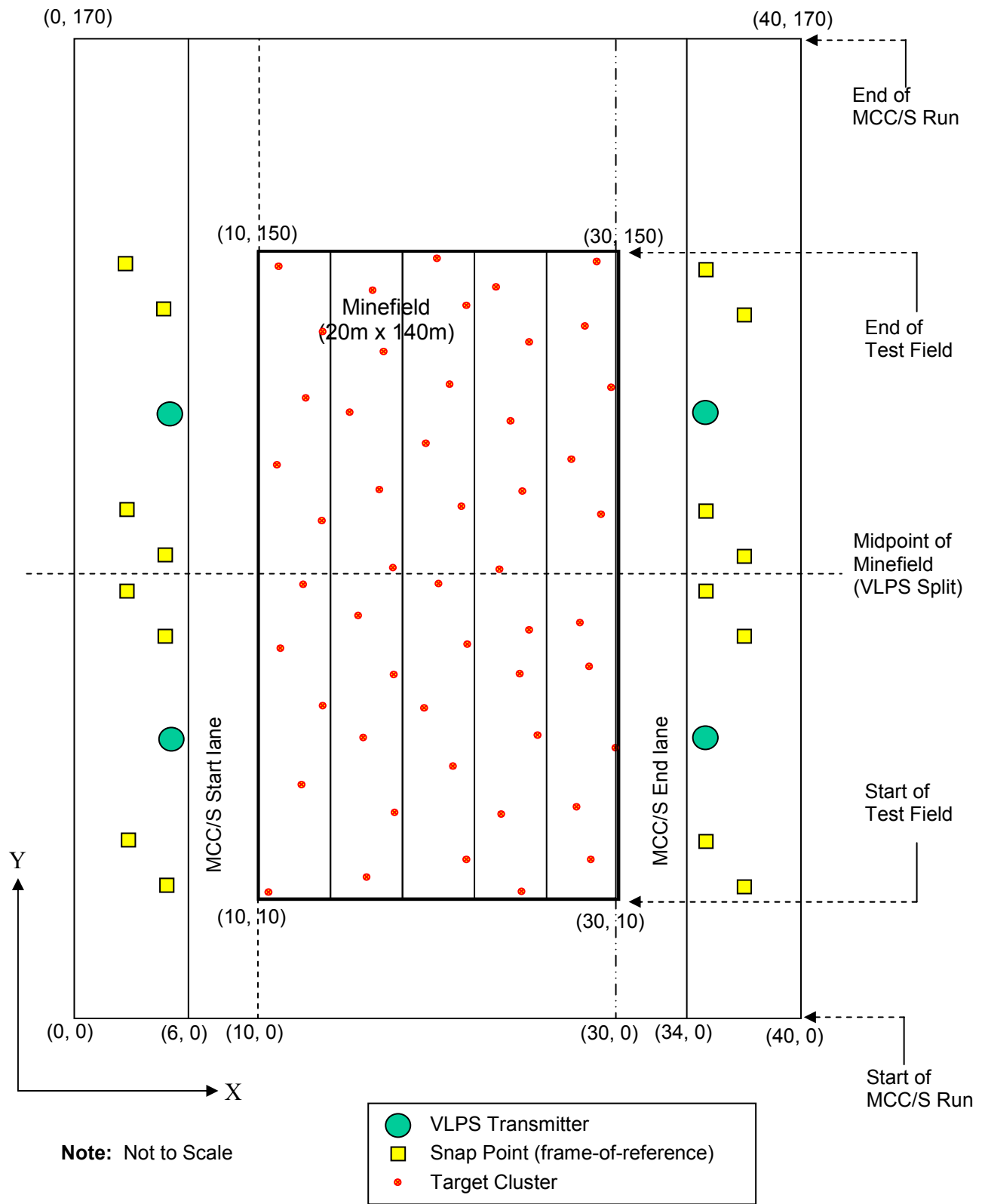

Figure 21: MCC/S Test Area Including Minefield and VLPS Layout

3.3.2 Operational Test Procedure

At Test Sites 1 and 2, the first pass made with the MCC was along the left-hand outside edge of the minefield. This allowed the operator time and distance to adjust the cultivator to the local soil conditions, i.e., maintaining cultivator depth, and the effect of sod. Each subsequent pass through the mined area was started at a point 10 meters before entering the minefield to allow an adequate distance to set the cultivator depth. Cultivating then continued to a point approximately 20 meters beyond the end of the minefield where the operator stopped forward movement, raised the cultivator, and backed down the vehicle track line to the point where cultivating started. The MCC was then positioned for the next pass.

Each step of the minefield clearing process executed during the test was timed in order to provide planning factors for actual operations. Cultivation time included the time for each pass (cultivating swath) and of each backing up incident (to remove mines, return to starting point, any EOD activity, maintenance, etc.). Additionally, all non-cultivating activities were timed. This included the time to start and adjust the SRCS at the start of each day, all maintenance activities, both scheduled and unscheduled, time to change out the cultivator and sifter, and so forth.

Finally, the MCC/MCS test engineer reserved the option to adjust cultivating and sifting procedures followed during the test to allow for refinement of operational procedures based on varied soil and vegetation conditions. This flexibility provided the greatest opportunity to determine optimal operating procedures.

Testing took place only when measured soil moisture content was at 25% or less.

3.3.3 Operational Test Results from Individual Test Sites

3.3.3.1 Test Site 1: Sandy Loam with Sod

The expectations for this test were reduced after the results of the standardized testing of the cultivator in sod-covered soil. The test was started but it was found that the soil and sod build-up in the cultivator was so extensive that it adversely affected the operational usefulness of the equipment. The problem was the combination of long grass, its soil-holding root system, and soil moisture content which caused a heavy build-up of soil and sod both in front of and within the tines of the cultivator (see Figure 22). The build-up in front of the cultivator negated the functioning of the depth sensors to maintain the cultivator's operating depth. The weight and volume of the sod and soil build-up in front and within the cultivator became so great that, at times, the tractor was not able to move. The test was stopped after one and a half passes into the minefield. While some performance data was recorded, it was not statistically significant and no valid quantitative conclusions could be drawn. This portion of the test was halted and the mines removed from the minefield.



Figure 22: Sod Build-up In Front and Within the Cultivator's Tines

3.3.3.2 Test Site 1: Sandy Loam with No Sod

After the removal of the mines, the cultivator was used to remove the sod ground cover. The mines were then reburied as shown in Figure 20. The cultivator worked reasonably well in the soil with the sod removed. However, the cultivator still experienced some soil build-up due to the root system that remained in the soil, and the moisture content after the sod had been cleared. This root system/soil build-up was not significant enough to stop the equipment from completely clearing the minefield.

It was during this phase of the test that it was realized that taking the soil moisture readings at the surface were not a good measure of the operating environment. Discrepancies existed between measurements at the surface and at the operating level of the cultivator. Heavy rain during the test period resulted in the soil moisture measurements being higher at the operating depth of the cultivator than those taken on the surface.

After the minefield was cultivated, the sifter was installed on the Liebherr tractor. The soil moisture level at the time of the test proved to be too much of a problem for the sifter. The soil, still quite damp at 10-12 inches, caused the dirt to come up in very large clumps. This put an excessive strain on the belt. The soil moisture level also caused the dirt to stick together and not break up as it was processed up the sifting belt. This greatly reduced the sifter's effectiveness in finding mines. The sifting part of the test was suspended after attempting to sift one and a half passes (lanes).

The following comments apply to similar data tables presented for tests at Sites 1, 2 and 3. In the tables showing the results of the tests at the test sites, the reason for recording the number of mines seen by the remote MCC operator was to determine if the remote operators of the equipment and cameras would be able to spot an AT mine on the camera-fed monitors when the mine appeared in the cultivator. The operational intent is that the equipment operator, when an AT mine is seen, would stop the prime mover, raise the cultivator, and back away from the AT mine. EOD personnel would then dispose of the mine. The equipment and camera operators were able to spot about 80% of the AT mines processed by the cultivator.

Due to the undulations of the ground surface at Site 1, compounded by a lag in time between the depth sensor signal generation and the response of the hydraulic depth control system, maintaining a constant cultivator tine working depth was very difficult. The result is that 10 (20%) of the AT test targets were stabbed or damaged by the cultivator tines. Three of the 31 smoke-fused mines were activated.

Since the MCC was tested in conjunction with the sifter (MCS), the intent was that the sifter would be used to recover mines not processed by the MCC. Therefore, the accounting for targets in Tables 8, 9, and 10 is not made until after the minefield is processed by the sifter.

Table 8: Test Site 1 (Sandy Loam) Minefield Test – Processing Results

Equipment		MCC		MCS	
Mine Type		AT	AP	AT	AP
PROCESSING RESULTS					
	Test Targets	50	100	7 [†]	44 [‡]
	Seen by Ground Observer¹	44	47	1	4
	Seen by Operators²	41	47	1	4
	Processed through MCC³	28	15	0	0
	Passed through MCC⁴	3	17	0	0
	Stayed in Berm⁵	2	1	0	0
	Reburied⁶	0	3	0	0
DAMAGED TARGETS					
	Stabbed/Damaged (not processed)	8	0	0	0
	Stabbed/Damaged (processed)	2	2	0	0
	Activated	3 [†]	0	0	0
ACCOUNTING FOR TARGETS					
	Test Targets	50	100	7	44
	Processed/Exposed	43	56	2	7
	Missed	7	44	5	37
	Dug Up	0	0	3	16
	Found Later	0	0	2	5
	Total Not Found	7	44	0	16

¹ Test targets seen by ground observers in area around the equipment in operation.

² Test targets seen in control vehicle by operator and/or co-operator on remote camera screens.

³ Test targets processed through the MCC as designed (exiting from the left or right of the auger).

⁴ Test targets passed under the vehicle and exited behind it or were run over by the vehicle.

⁵ Test targets found in the berm at the end of lane including those still in front of the auger when the end of the lane was reached.

⁶ Test targets seen when exposed by the equipment but covered by processed dirt and not clearly visible by the ground observers.

[†] Only the round antitank mines (AT-r/m) contained smoke fuses to indicate mine activation (see Table 5).

[‡] Test targets missed by the Mine Clearing Cultivator (MCC) became the test targets for the Mine Clearing Sifter (MCS).

Processing distance data for the MCC confirms the results of the standardized test processing distances. The significant result is that the proper way to insure that mines carried out of the minefield into the end-berm are found, is to process the end-berm either by hand-held metal detectors and probes or by some sort of sifting system.

Table 9: Test Site 1 (Sandy Loam) Minefield Test – Processing Distances (meters)

Equipment		MCC		MCS	
Mine Type		AT	AP	AT	AP
CROSS-TRACK (X AXIS)					
	Min. Processing Distance	0.008	0.001	4.969	3.987
	Max. Processing Distance	3.917	1.586	6.895	11.500
	Average Processing Distance	1.168	0.370	5.932	6.727
	Median Processing Distance	1.015	0.262	5.932	6.373
	Std. Dev. Processing Distance	0.985	0.368	1.362	2.426
DOWN-TRACK (Y AXIS)					
	Min. Processing Distance	1.853	0.116	2.758	3.584
	Max. Processing Distance	119.482	20.628	12.488	54.503
	Average Processing Distance	23.600	3.109	7.623	31.123
	Median Processing Distance	15.938	1.998	7.623	33.579
	Std. Dev. Processing Distance	25.936	3.629	6.880	20.441

3.3.3.3 Test Site 2: Sandy Clay with No Sod

The cultivator/sifter combination worked very well in the sandy clay soil at Test Site 2. It did rain during the test dates but the ground drained and dried sufficiently fast enough so as not to impede the performance of the equipment. Also, the area selected for the minefield had been used for other equipment testing and was devoid of any surface vegetation and all residual vegetation root systems. Therefore, there were no problems with sod and soil build-up within the cultivator. All the mines were found but, due to human error, the location data for one mine was missing. The mine’s final location was not used in the statistical analysis.

While the number of mines damaged was fewer than at Test Site 1, the four stabbed mines indicated that there were still problems with maintaining cultivator tine operating depth. The ground surface was not completely flat and the slight undulation did cause the cultivator depth control system to constantly adjust the cultivator’s depth. When the automated depth control system was shut off and the cultivator’s depth was manually controlled by the remote operator, the operator was able to maintain proper operating depth without interfering with his other driving functions.

Four of the 34 mines containing smoke fuses were activated. These results are similar to those from the Test Site 1.

Table 10: Test Site 2 (Sandy Clay) Minefield Test – Processing Results

Equipment		MCC		MCS	
Mine Type		AT	AP	AT	AP
PROCESSING RESULTS					
	Test Targets	50	100	1	26
	Seen by Ground Observer	48	62	0	22
	Seen by Operators	38	21	0	3
	Processed through MCC	38	42	0	19
	Passed through MCC	3	41	0	1
	Stayed in Berm	2	2	0	0
	Reburied	2	12	0	2
DAMAGED TARGETS					
	Stabbed/Damaged (not processed)	4	4	0	0
	Stabbed/Damaged (processed)	2	2	0	0
	Activated	4*	0	0	0
ACCOUNTING FOR TARGETS					
	Test Targets	50	100	1	26
	Processed/Exposed	49	74	0	25
	Missed	1	26	1	1

*Only the round antitank mines (AT-r/m) contained smoke fuses to indicate mine activation (see Table 5).

Note for Table 10: Test targets missed by the Mine Clearing Cultivator (MCC) became the test targets for the Mine Clearing Sifter (MCS).

Again, the MCC processing distance in the minefield supports the data collected during the standardized tests.

Table 11: Test Site 2 (Sandy Clay) Minefield Test – Processing Distances (meters)

Equipment		MCC		MCS	
Mine Type		AT	AP	AT	AP
CROSS-TRACK (X AXIS)					
	Min. Processing Distance	0.020	0.001	0.000	0.054
	Max. Processing Distance	3.494	2.631	0.000	4.352
	Average Processing Distance	1.256	0.458	0.000	2.231
	Median Processing Distance	1.161	0.196	0.000	2.199
	Std. Dev. Processing Distance	0.781	0.567	0.000	1.016
DOWN-TRACK (Y AXIS)					
	Min. Processing Distance	0.075	0.019	0.000	0.062
	Max. Processing Distance	43.627	14.171	0.000	15.489
	Average Processing Distance	9.754	2.936	0.000	2.982
	Median Processing Distance	6.180	1.577	0.000	1.612
	Std. Dev. Processing Distance	10.343	3.637	0.000	4.614

3.3.3.4 Test Site 3: Sand with No Sod

Since the sifter was previously tested in sand (see Appendix A), this test was limited to the testing of the cultivator against AT mines buried in sand. Due to the smaller dimensions of Test Site 3, multiple runs were made to gather AT processing data on 50 mines—the same number of AT targets used at Sites 1 and 2. A total of four runs were made to clear the smaller test area of the 50 mines (AT mines were buried four times in the sand area in groups of 13, 13, 12, and 12). The data gathered was considered statistically valid for the final analysis.

Figure 1 on page 2 and Figure 9 on page 7 show that the sifter has a large metal scoop on the front edge used to lift soil (and soil containing mines) into the sifter. When in operation, a fair amount of soil, and whatever happens to be buried in the soil, accumulates on this leading-edge scoop. As new soil is pushed onto the front scoop, soil on the scoop is pushed off the back of the scoop onto the sifting belt. Also, it was noticed that if the front edge of the scoop does not get under a buried mine, but rather engaged the side of a mine, it tended to push the mine through the sand until the mine tilted in the horizontal plane and the scoop could get under the mine and lift it to the surface.

Table 12: Test Site 3 (Sand) Minefield Test – Processing Results

PROCESSING RESULTS		MCS/AT [†]
	Test Targets	50
	Seen by Ground Observer	48
	Seen by Operators	43
	Processed through MCS	27
	Passed through MCS	0
	Stayed in Berm	21
	Reburied	0
DAMAGED TARGETS		
	Stabbed/Damaged (not processed)	0
	Stabbed/Damaged (processed)	0
	Activated	0/34 [‡]
ACCOUNTING FOR TARGETS		
	Test Targets	50
	Processed/Exposed	48
	Missed	2

[†] Results are for the MCS with AT test targets.

[‡] Only the round antitank mines (AT-r/m) contained smoke fuses to indicate mine activation (see Table 5).

The processing distances data for the MCS in sand were similar in magnitude to those experienced at Test Sites 1 and 2. The y-distance movement of the mines gives some indication why so many mines ended up in the end berms. Fortunately, since sand is an easy soil medium to work through, those in the berms were not difficult to locate.

Table 13: Test Site 3 (Sand) Minefield Test – Processing Distances, MCS Only (meters)

X Axis		MCS/AT [†]
	Min. Processing Distance	0.082
	Max. Processing Distance	3.809
	Average Processing Distance	1.238
	Median Processing Distance	1.095
	Std. Dev. Processing Distance	0.916
Y Axis		
	Min. Processing Distance	0.175
	Max. Processing Distance	73.327
	Average Processing Distance	21.641
	Median Processing Distance	16.221
	Std. Dev. Processing Distance	19.177

[†] Results are for the MCS with AT test targets.

3.3.4 Operational Test Results Summary

The original test plan called for measuring the time to cultivate and sift the minefields at Test Sites 1 and 2 without any prior preparation of the test sites. However, as explained earlier in the report, at Site 1, only the cultivating operation was completed, once the surface vegetation was removed. At Site 2, the cultivating procedure followed at Site 1 was modified. Two-thirds of the minefield was cultivated with a 50% overlap of the previous pass to determine if mines that might have been missed the first time would be caught the second time. This was not the case. In fact, the overlapping tended to lower the efficiency of the operation since the previously cultivated side caused that side of the prime mover to ride high, thus making it more difficult to maintain an even cultivator operating depth across the width of the cultivator. Test Site 3 data is not included in the summary charts since the MCC was not used in a minefield test and the sifter was tested only against AP mines.

The cultivating rate was 1093 m²/hr on Site 1 (after sod was removed), and 778 m²/hr at Site 2. As one would expect, the cultivation rate at Site 2 was lower than at Site 1 due to time lost when cultivating with the 50% overlap.

Table 14: Time to Cultivate and Sift

Minefield	Area Cultivated/Sifted	Time to Cultivate	Time to Sift	Cultivating Rate
Site 1: Sandy Loam	2800 m ² / [†]	2 hrs 34 min	[†]	1093 m ² /hr
Site 2: Sandy Clay	3738 m ² [‡] / 2800 m ²	4 hrs 47 min	2 hrs 42 min	778 m ² /hr

[†] Test terminated due to soil moisture.

[‡] 2/3 of the minefield cultivated with 50% overlap; 1/3 with 0% overlap.

Tables 15 and 16 summarize and recap the test results presented in Tables 8 through 11.

Table 15: Targets Processed and Missed by MCC/MCS

Test Site	SITE 1: SANDY LOAM				SITE 2: SANDY CLAY			
Equipment	MCC		MCS		MCC		MCS	
Target Type	AT	AP	AT	AP	AT	AP	AT	AP
TEST TARGETS	50	100	7	44	50	100	1	26
PROCESSED/EXPOSED	43	56	*	*	49	74	0	25
MISSED	7	44	*	*	1	26	1	1

*Test terminated due to soil moisture.

Note for Table 15: Test targets missed by the Mine Clearing Cultivator (MCC) became the test targets for the Mine Clearing Sifter (MCS).

As shown in Table 15, the MCC processed 43 of 50 AT mines and 56 of 100 AP mines in sandy loam soil before the test was terminated due to excess moisture. In sandy clay, the combination of the MCC and MCS processed 148 out of 150 test targets (AT and AP mines). Table 16 shows that the average down-track (y-axis) movement of AT mines while being processed by the MCC varied from 9.75 m to 23.6 m, and from 2.94 m to 3.11 m for AP mines. The shorter distance for AP mines is attributed to their being buried right at the surface as opposed to the 6-inch depth for the AT mines. Cross-track (x-axis) movement was within the working width of the cultivator and the sifter (to include the added width of the exit MCS chute). It should be noted that for the mines activated, none were damaged targets. But anytime that a mine, and especially an AT mine, is damaged by the cultivator, the possibility exists that a mine could be detonated.

Table 16: Processing Distance & Damage of Targets through Test Cycle

Test Site	SITE 1: SANDY LOAM		SITE 2: SANDY CLAY	
Target Type	AT	AP	AT	AP
PROCESSING RESULTS				
MCC Avg. Processing Dist. (x-axis)	1.17 m	0.37 m	1.26 m	0.48 m
MCC Avg. Processing Dist. (y-axis)	23.60 m	3.11 m	9.75 m	2.94 m
MCS Avg. Processing Dist. (x-axis)	5.93 m	6.73 m	0	2.23 m
MCS Avg. Processing Dist. (y-axis)	7.62 m	31.12 m	0	2.92 m
DAMAGED TARGETS				
Stabbed/Damaged (not processed)	8	0	4	4
Stabbed/Damaged (processed)	2	2	2	2
Activated	3	0	4	0

Table 17 is a summary presentation of the results of the standardized tests conducted with the MCC at Test Sites 1, 2 and 3. At Site 1, once the sod was removed, the MCC process all 12 targets. Site 2 results were the same. However, at Site 3, in sand, the straight auger fingers did not force the sand to flow, and with it the mines, to the outside of the sifter. Therefore, the uncovered mines kept rolling along within the cultivator. Once the straight fingers were replaced with twisted fingers, all exposed mines were processed by the MCC. The down-track (y-axis) processing distance was slightly longer than that experienced in the minefield tests discussed in Table 16. The improvement between the two test results is attributed to additional experience of the operator and the drier soil conditions during the minefield tests.

Table 17: Results of the MCC Standardized Tests

Location	SITE 1		SITE 2	SITE 3	
Soil Type	Sandy Loam		Sandy Clay	Sand	
Soil Surface	Sod [†]	No Sod	No Sod	No Sod	
MCC Auger Finger Design	Straight	Straight	Straight	Straight	Twisted
ACCOUNTING FOR TARGETS					
Total Test Targets (AT only)	12	12	12	12	12
Processed/Exposed	10	12	12		12
Targets Missed	2	0	0	12 [‡]	0
DAMAGED TARGETS					
Stabbed/Damaged (processed)	1	1	0	N/A	0
Stabbed/Damaged (not processed)	4	2	0	N/A	0
Activated	2	0	0	N/A	0
PROCESSING DISTANCE (m)					
Minimum (y-axis)	9.12	0.56	8.8	N/A	3.34
Maximum (y-axis)	63.91	44.19	51.10	N/A	54.21
Average (y-axis)	23.94	20.16	24.18	N/A	18.74

[†]Test was not conducted with normal operating procedures (see text, Section 3.2.4.4).

[‡]Test terminated.

3.4 Test Data Analyses

3.4.1 Data Collection

The Vulcan Laser Positioning System (VLPS) was used to record target-positioning data. The VLPS recorded the targets' initial buried positions and final positions after being processed by either the Mine Clearing Cultivator, the Mine Clearing Sifter, or both. The VLPS is a laser positioning system that allows very accurate and precise measurements in three axes by use of local positioning transmitters. A basic system consists of two laser transmitters that are set up in fixed positions and a receiver pole that can be placed anywhere in the range of the transmitters. The range of the laser transmitters determines the useful positioning area. The transmitters must have clear sight to the receiver pole to allow measurements. The receiver pole has a receiver unit and a

handheld computer attached to it to store the relative location (to a baseline reference point) of each target. Each target was given a numerical code for identification purposes. This location measurement data can then be downloaded to a desktop or laptop PC and then converted into a format that can be analyzed. To set up a fixed frame, “snap points” (reference points) had to be designated and marked in the area and on the handheld computers. When the system is set up, these snap points are entered into the system and a coordinate system is set up based on those points. The system can be used on successive days at the same location by marking these snap points physically and then re-entering them daily.

Members of the test team recorded times to cultivate and sift, measurements of areas cultivated and sifted, and on-the-ground observations.

3.5 Human Factors Assessment

3.5.1 Operator Visibility and Fatigue

The operator’s visibility while operating the MCC/MCS remotely was excellent. The ability to move the three forward-looking cameras allowed the operator to hold a straight line, even over distances approaching 200 meters. The side cameras allowed the operator to follow the track of the previous cultivating pass, thus insuring there were no cultivating voids. Using the two side cameras, the operator was also able to maintain a constant cultivator operating depth across the width of the cultivator, and by use of the center camera, to maintain an even operating depth from front to rear. The rearward-facing camera, also movable, permitted the operator to back out of the minefield in the same track path generated while cultivating.

The operator did comment that after an hour or so, constantly monitoring the progress through use of the closed circuit monitors tended to have a hypnotic effect on him. He also suggested that redundant depth control switches be mounted on the camera control box so the camera operator could assist in the chore of maintaining constant operating cultivator depth.

When driving the MCC/MCS into the sun, the sun shining into the cameras will wash out the pictures on the camera monitors. When the sun is behind the cameras, the shadow of the prime mover on the cultivator or sifter makes it impossible for the operator to see the rear of the cultivator and very difficult to maintain constant operating depth of the tines from front to rear.

Operating the MCC/MCS from inside the cab is also an easy chore for the operator. Forward visibility of the working area is excellent, with unobstructed views from about 6 feet in front of the tractor to the horizon. There is some masking of the rear of the cultivator, making it more difficult to maintain an even fore-aft constant operating depth of the tines. Visibility when backing out of the minefield is more of a chore due to the inability of the operator to see the ground immediately behind the tractor due to the hydraulic power unit.

3.6 Logistics

3.6.1 Transportability

The MCC/MCS, including the Liebherr prime mover, will be shipped along with the specific tools required for field maintenance.

For shipping, the MCC cultivator tines and auger fingers are removed. The auger is removed from the cultivator. The cultivator and cultivator tines are strapped to a single pallet. The auger and auger fingers are strapped to a separate pallet. The MCS (sifter) is loader on a flatbed trailer. Spare parts and tools are loaded in a 20-foot ISO container. The mine-clearing blade is shipped on two pallets.

3.6.2 Turning Radius

The turning radius was determined for a pivot turn. Due to no loss of control when remotely operating the tractor with either the MCC or MCS attached, there were no differences in the turning radius measurements taken for manual and remote operation.

Table 18: Turning Radius

Configuration	Turning Radius, Operator		Turning Radius, TeleOp	
	feet	meters	feet	meters
Tractor with cultivator, pivot turn	20 ft 6 in.	6.25 m	20 ft 6 in.	6.25 m
Tractor with sifter, pivot turn	21 ft 6 in.	6.5 m	21 ft 6 in.	6.5 m

3.6.3 Mobility

No formal mobility test was conducted. However, given the weight distribution of the installed system on the Liebherr tractor, with the HPU at the rear and the MCC or MCS on the front, there were no indications that there would be any mobility limitations restricting the MCC/MCS from going wherever the Liebherr tractor could go itself.

No measurements of angles of approach or departure were taken since neither the MCC nor MCS are envisioned being used on anything but reasonably level terrain. Movement to a work site involving the need to climb or descend hills will pose no problem for the tractor since the MCC and MCS can be lifted a minimum of 1 meter off the ground.

During cultivating operations, forward speed averaged 0.6 to 0.8 kph, independent of the soil type. Speeds when backing out of the minefields ranged from 1.4 to 2.8 kph. Since the operator had considerable experience in remotely operating the MCC, the above speeds are considered to be about optimum for the existing conditions and soils.

3.6.4 Routine Servicing and Maintenance

Routine servicing took place on a daily basis and included checking of all fluids, greasing fittings on major components, and checking the operation of all electronic systems.

3.6.5 Consumables

After the test, it was discovered that the fuel log had not been kept up-to-date and was impossible to reconstruct with assurance of accuracy. The hydraulic oil log was complete, however. A total of 3.5 gallons (15.9 liters) was added to the reservoir serving both the tractor and the HPU.

3.7 Maintenance/Modification Issues

3.7.1 Unscheduled Maintenance Incidents During Testing

1. During a routine inspection of the tines of the MCC after the trials at Test Site 1, cracks were found along the welds between the connecting bar and the tines (see Figure 23). A welding unit was brought in and the cracks were fixed within an hour. The remainder of the test was completed with no new cracks developing.



Figure 23: Cracks Found on the MCC

2. A major concern was the main conveyor belts on the MCS. In previous tests, it was found that operating the sifter with heavy loads (very moist or rocky soil) could cause the main sifting belt to stretch, causing it to override the drive sprockets. While care was taken to prevent this from happening during this test, a belt was found to have stretched excessively from the limited work done at Test Site 1 (in soil with 25% to 30% moisture levels at 8 inches depth). The main sifting belt was opened at the closing (master) link, unfastened from the MCS and tightened by shortening the belt by removing one bar and its webbing.



Figure 24: Loose MCS Belt Repair

3. There were early morning problems with the cameras on two separate occasions. It turned out that overnight condensation during a period of high humidity caused internal condensation resulting in inoperable cameras. The work-around solution adopted for the cameras was to cover the cameras with heavy plastic bags sealed with ties to the camera mast when not in use.

4. Two of the four depth sensors went out during the test. They were repaired by recalibration of all sensors.

5. During the minefield test at Site 2, the MCC auger depth control started to malfunction, causing the auger to run deep. The result was that two AT mine were pulled over the auger causing the smoke fuses to be detonated on the backside of the auger. The auger control was recalibrated.

3.7.2 System Change-Out

The MCC/MCS system was changed out four times during the test. As expected, early system change-outs took longer than ones near the end of testing as experience was gained with the process. The key activity was the alignment of the C-frame to the tractor, which required at least two people (three were used) to properly align the C-frame to the mounting flanges and then attach the C-frame. On the third change-out (removing the cultivator and attaching the sifter), the time required was 47 minutes.

3.7.3 Auger Fingers Change-Out

The auger fingers were changed twice during the test, once at the beginning of testing and once, from straight fingers to twisted fingers, during the sand soil test at Test Site 3. However, an unanticipated problem arose.

After installing the twisted fingers for the sand soil test, it was discovered that there is a right-hand and left-hand twist to the fingers. The twisted auger fingers had been installed on the wrong sides. This necessitated removing and reinstalling the twisted fingers on the proper sides. This situation could have been avoided if both the left-hand and right-hand fingers had been stamped with an 'L' or 'R' to indicate the side of the auger on which they were to be mounted.

4 TEST SUMMARY ASSESSMENT

4.1 Mine Clearing Cultivator

The Mine Clearing Cultivator is an effective piece of equipment when used in the right environment. It does very well in dry or almost dry soils regardless of the soil composition. It also does well in sparse or light vegetation. In sand soil, it effectively processes mines when the twisted fingers are installed on the auger. However, it was found to have problems in soil with mature, solid field grass. The grass, with its roots and attached soil, tended to build-up in front of and within the tines of the cultivator, forming a moving berm in front of the cultivator. The front berm of sod and soil debris blocked the depth control sensors' view of the ground, causing the system to lift the tines from the soil. The mass of the front berm and sod and soil accumulated in the cultivator created sufficient load and drag to slow and, in one case, stall the prime mover. Also, elevated levels of soil moisture (above 20-25%) caused problems with the effectiveness of the equipment. Moisture content at the cultivator's working depth was found to have as much or more impact on the performance of the cultivator as the moisture content at the surface. Unfortunately, due to prevailing weather conditions during the period of the test, the MCC was not tested in a sod-covered field when the soil was very dry.

The MCC should be an effective area reclamation tool for the demining community if reasonable consideration is given to the operational environment, appropriate soil conditions, and operators wait until local soil moisture content is low.

4.2 Mine Clearing Sifter

The Mine Clearing Sifter performed well under the conditions of the test. Like the MCC, the Sifter also had problems with high-moisture content soils. Very moist soil clumped together and did not break up sufficiently to insure that no AP mines were encased in the muddy soil. The weight of the wet soil and clay also put stress on the main conveyor belts of the sifter, causing them to stretch to a point where the belts would override the drive sprockets. Since heavy, moist soil did not sift through the sifting belt, it was discharged to the side forming large (high) windrows that buried processed mines, making separate processing of the windrows mandatory. In the moderately moist soil conditions of Site 2, with a soil moisture content of less than 20 %, and in sand at Site 3, the sifter worked very well.

4.3 Standardized Remote Control System (SRCS)

The SRCS performed well throughout the whole test. Video reception was excellent. At no time was radio contact lost with the receiving unit on the MCC/MCS.

There were some problems related to moisture condensation. These were quickly repaired in the field. The major control problem was the response time between the depth sensors and the cultivator depth control valve.

4.4 Hydraulic Power Unit

There were no problems with the hydraulic power unit.

5 RECOMMENDATIONS

- Understand what the environmental operating limitations are for the cultivator. Heavy (tall) field grass cover should be avoided or removed before cultivating. Even so, the remaining root structure in the soil, if extensive and the soil moist, will severely degrade the MCCs performance.
- Plan remote control operations so that the sun is neither directly in front nor directly behind the MCC. The sun in front can wash out the cameras, the sun behind will put the MCC in enough shadow to make it very difficult to maintain constant cultivator operating depth.
- Install a redundant depth control switch on the camera control box allowing the camera operator to assist the MCC operator in maintaining proper cultivator operating depth.
- The depth control system and hydraulic system need to be better integrated and coordinated to deal with changes in topography relative to the speed of the vehicle and to improve the response time between the depth sensors and the cultivator depth control valve.
- Center fingers in the middle of the auger combined with the presence of the center structural bar (see Figure 25 below) tend to roll mines forward instead of to the side and out the auger. Redesign of the center left and right auger fingers and the structural center bar should induce a mine coming into the very center of the auger to move to one of the sides.



Figure 25: Mine Caught Under Center Bar

- Overlapping cultivator passes resulted in the cultivator not maintaining a constant cross-track cultivating depth. It is recommended that there be no overlap when making cultivating passes.
- A belt tensioner should be installed to take up the slack in the main sifter belt as it stretches from use.
- Increase the flare of the sidebar grills to minimize the opportunity for spillage of dirt and mines outside the sifter's working width.
- The forward-looking camera's depth of field is not sufficient to allow the remote operator to get a visual cue of upcoming undulations in the ground in front of the cultivator that could affect the operating depth of the cultivator. Recommend increasing the operating depth of field for the camera.
- Recommend that the auger fingers be stamped with an 'L' or 'R' to indicate the side of the auger on which they should be installed.
- Provide permanent waterproof canvas covers, lens caps, and sunshades for the cameras.

6 CONCLUSIONS

When the cultivator and the sifter are used in environmental (soil, vegetation and moisture) conditions that are within the operational parameters as discussed in Sections 4 and 5, they are effective humanitarian demining tools.

GLOSSARY

AP	antipersonnel
AT	antitank
CERDEC	Communications and Electronic Research, Development and Engineering Center
COTS	commercial off-the-shelf
deg	degrees
EOD	explosive ordnance disposal
FMB	Floating Mine Blade
ft	feet
gpm	gallons per minute
HDPMO	Humanitarian Demining Program Management Office
HD R&D	Humanitarian Demining Research and Development
HLS	Heartlands Sifter
HP	horsepower
HPU	hydraulic power unit
hrs	hours
IDA	Institute for Defense Analyses
kg	kilogram
km	kilometer
kph	kilometers per hour
l	litre
l/m	litres per minute
lb	pound
m	meter
MCC	Mine Clearing Cultivator
MCS	Mine Clearing Sifter
mHz	megahertz

min	minutes
mm	millimeters
mph	miles per hour
MRM	mechanical reproduction mine
NVESD	Night Vision Equipment and Sensors Directorate
psi	pounds per square inch
RCV	remote command vehicle
RDECOM	U.S. Army Research, Development and Engineering Command
SRCS	Standardized Remote Control System
SUV	sport utility vehicle
VLPS	Vulcan Laser Positioning System

APPENDIX A
HEARTLANDS SIFTER

**Operational Evaluation Test
of
Mine Clearing Cultivator and
Mine Clearing Sifter,
Appendix A: Heartlands Sifter**

September 2004

Prepared by

Institute for Defense Analyses
4850 Mark Center Drive
Alexandria, VA 22311-1882

for

**Humanitarian Demining Research
and Development Program**
Night Vision and Electronic Sensors Directorate
10221 Burbeck Road, Suite 430
Fort Belvoir, VA 22060

**Office of the Assistant Secretary of Defense
Special Operations and Low-Intensity Conflict**
2500 Defense Pentagon
Washington, DC 20301-2500

FOREWORD

The success of the Heartlands Sifter test program is attributable to the work and diligence of the test team from the U.S. Army's Research, Development, and Engineering Command; Communications-Electronics Research, Development and Engineering Center; Night Vision and Electronic Sensors Directorate; Countermine Division; Humanitarian Demining Branch (RDECOM-CERDEC-NVESD-HD). Mr. Gregory Bullock, the Test Director, provided test direction and coordination. The Test Engineer responsible for all field test activities was Major Sewaphorn Rovira, USA. Mr. J. Michael Collins was the Project Engineer responsible for all modifications and field repairs to the system before and during the test program. Mr. Ronald Collins was the system's operator.

SFC Christopher Andres, USA, and Mr. Arthur Limerick, a senior member of the development test site staff, prepared the test sites and provided field test support. Major Rovira wrote this report with assistance from Mr. Harold Bertrand and Mrs. Sherryl Zounes of the Institute for Defense Analyses.

CONTENTS

1	Introduction	A-11
1.1	Background	A-11
1.2	Objective	A-11
2	Equipment Description	A-11
2.1	Heartlands Sifter (HLS)	A-11
3	Test Description, Procedures and Results	A-13
3.1	Test Sites	A-13
3.2	Test Targets	A-13
3.3	Test Lane Mine Layout	A-14
3.4	Soil Sifting and Mine Clearing Tests	A-15
	3.4.1 Soil Sifting Results	A-15
	3.4.2 Mine Clearing Results	A-19
3.5	Tire Ground Pressure Test	A-23
3.6	Mine Actuation Assessment.....	A-24
3.7	Safety Evaluation	A-24
	3.7.1 Operator’s Safety	A-25
	3.7.2 Safe Land.....	A-25
3.8	Maintenance Evaluation.....	A-25
4	Observations and Recommendations	A-26
5	Summary	A-26

FIGURES

Figure A-1: Heartlands Sifter.....	A-12
Figure A-2: Outline of HLS.....	A-12
Figure A-3: Floating Mine Blade (out of ground).....	A-13
Figure A-4: Floating Mine Blade (in ground).....	A-13
Figure A-5: Test Targets.....	A-14
Figure A-6: Layout of Test Lane and Test Targets.....	A-15
Figure A-7: Cultivated Test Lane.....	A-17
Figure A-8: Sifted Test Lane and Berm.....	A-17
Figure A-9: Sifted, Cultivated Lane.....	A-18
Figure A-10: Sifted, Cultivated and Sifted Lane.....	A-18
Figure A-11: HLS Operating in Sand.....	A-18
Figure A-12: Sifted Sand Lane with End-Berm.....	A-18
Figure A-13: Cultivated Light Clay with Sod.....	A-19
Figure A-14: HLS Sifting Light Clay and Sod.....	A-19
Figure A-15: Mine on Sifter Belt.....	A-22
Figure A-16: Another Mine on Sifter Belt.....	A-22
Figure A-17: Mine on Cross Conveyor.....	A-22
Figure A-18: Mine Deposited at Side of Sifter.....	A-22
Figure A-19: Mine Deposited in Berm.....	A-23
Figure A-20: Lane End Berm from HLS Front Scoop.....	A-23
Figure A-21: Mine Layout for Pressure Test.....	A-23
Figure A-22: Broken Drive Chain.....	A-26
Figure A-23: Broken Sifting Belt.....	A-26

TABLES

Table A-1: Dimensions of the Heartlands Sifter.....	A-12
Table A-2: Test Site Description.....	A-13
Table A-3: Test Targets.....	A-14
Table A-4: Soil Sifting Data.....	A-16
Table A-5: Mine Clearance Data.....	A-20
Table A-6: Targets Activated During Each Run.....	A-21
Table A-7: Tire Ground Pressure Test Results.....	A-24

1 INTRODUCTION

1.1 Background

The United States Department of State estimates that 80-110 million mines litter the world, the majority of which were deployed within the last 15 years. These mines kill and wound many people annually, mostly innocent civilians. Mines prevent growth and development in emerging or rebuilding countries, impede repairs to infrastructure, disrupt humanitarian aid shipments, and destroy the morale of civilians living close to the minefields.

Several efforts are underway that address the current landmine problem. One example is the Demining Assistance Program, established by the United States to initiate research and development into cost-effective demining techniques. The Department of Defense Humanitarian Demining Research and Development (HD R&D) Program at Night Vision and Electronic Sensors Directorate (NVESD) in Fort Belvoir, VA was tasked to execute this program.

The HD R&D Program adapts and develops numerous technologies to support individual deminers and demining operations. Examples include technologies for large area clearance, *in-situ* neutralization, wide-area detection, marking and mapping of landmines, and multi-media and mine-awareness training. The Heartlands Sifter (HLS) is a technology that the HD R&D Program adapted and modified for large-area clearance to be used as part of a toolbox of mechanical demining processes.

1.2 Objective

The objective of this test was to evaluate the operational effectiveness of a commercial, off-the-shelf (COTS) sifter, manufactured by Heartlands Group, North Carolina, to remove antipersonnel (AP) and antitank (AT) mines from various types of soils. The Heartlands Sifter (HLS) was tested under conditions approximating those found in real mined environments with 'easy' to 'moderate' degrees of difficulty for soil cultivation. The HLS tires were tested against various mine targets to assess whether the tires exerted enough ground pressure to activate the targets. Safety assessments were made including operator's safety and the land's 'safety from mines' after being cleared by the HLS. On- and off-road transportation of the HLS was evaluated, while logistical considerations, human factors, and maintenance issues were addressed and noted. Neither a blast test nor a survivability test was conducted on the system during this test.

2 EQUIPMENT DESCRIPTION

2.1 Heartlands Sifter (HLS)

The Heartlands Sifter (Figure A-1), originally designed and marketed as an agricultural sifting implement, was tested by the HD R&D Program to determine its ability to remove landmines with minimal risk to the operator and at a faster pace than manual demining

operations. Using customized mounting hardware, the HLS can be mated to various construction vehicles which function as the prime mover. The prime mover selected for this test was the Liebherr 742 crawler tractor with a four-point, C-frame hook-up. The Modeling and Mechanical Fabrication Shop of the U.S. Army Communications Command, Night Vision and Electronic Sensors Directorate (NVESD) Fort Belvoir, Virginia, integrated the HLS with the Liebherr tractor.



Figure A-1: Heartlands Sifter

The COTS HLS consists of everything forward of the Liebherr tractor (i.e., the sifting web, cross sifting web, and the tires) (see Figure A-1). An auxiliary hydraulic unit driven by a 175 HP diesel engine, mounted on the rear of the tractor, drives the sifter. The dimensions of the sifter are provided below in Table A-1 and depicted in Figure A-2.

Table A-1: Dimensions of the Heartlands Sifter

	Sifter	Measurements
A	Length	4.30 m
B	Width of the main web	3.12 m
C	Width (tire to tire)	4.72 m
D	Width of the Cross Sifting Web	0.24 m
	Height (not depicted)	1.70 m
	Weight (estimated)	7,257 kg

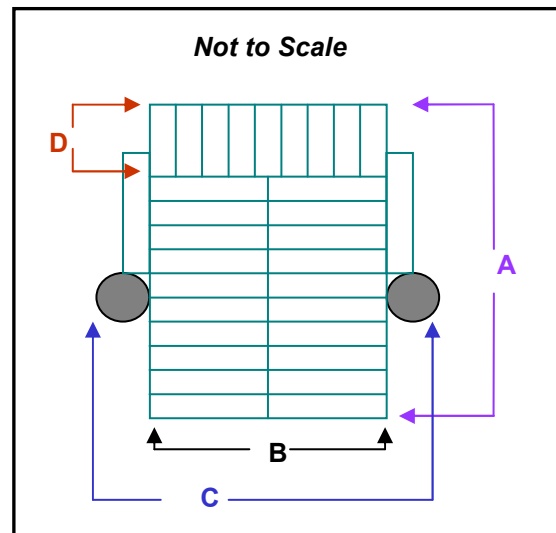

Figure A-2: Outline of HLS

3 TEST DESCRIPTION, PROCEDURES AND RESULTS

3.1 Test Sites

The HLS was tested at NVESD test sites during the periods 15-19 April and 29 April-3 May 2002. Tests were conducted at three different sites with the soil conditions described in Table A-2. The test sites were designated as Sites One, Two, and Three to correspond to the order in which they were used during the test program. A lane, three meters wide by 75 meters long (225 m²), was constructed at each site. The same lane was used for multiple runs at each site. The heavy-clay runs were conducted at Site One. Prior to the start of the tests at Sites One and Three, the test lane was cultivated by the Floating Mine Blade (FMB). After the lane was cultivated, test targets were buried and the HLS completed a run on the cultivated soil. Test targets were reburied in the same locations buried for the first run and the sifter test repeated in cultivated and sifted soil. The sandy-soil trials and the tire ground pressure tests were conducted at Site Two. The cultivated, light-clay trials were conducted at Site Three. The sandy soil at Site Two did not need to be cultivated prior to sifting. After each HLS run, it was necessary to level the soil in the test lane with the rake in preparation for the next run.

Table A-2: Test Site Description

Site	Terrain	Soil	Vegetation	Site Preparation/Restoration
One	Slightly sloping	Dirt, sandy loam and heavy clay mixture, with small rocks	Sparse grass covering	Cultivated with FMB; Tractor mounted rake
Two	Level	Sand	None	Rake mounted on a farm tractor
Three	Level	Topsoil, sandy loam, and light clay mixture, with small rocks	Complete grass covering	Cultivated with FMB; Tractor mounted rake.



Figure A-3: Floating Mine Blade (out of ground)



Figure A-4: Floating Mine Blade (in ground)

3.2 Test Targets

Ten different types of test targets were used. The test targets were a mix of inert mines, simulants, and mechanical reproduction mines (MRMs). The inert mine is an actual mine casing with the detonators and charges removed. The simulant and MRM targets are

representative of a specific mine in shape, size, weight and function. Each test target has a firing device or mechanism which indicates activation when appropriate force is applied to the target. The burial depth of the target was measured to the top of the target from the surface of the ground. The targets are listed in Table A-3 and shown in Figure A-5 below.

Table A-3: Test Targets

Nomenclature	Description
AT	AT mine simulat with smoke fuse
PAP	Inert Plastic AP blast mine
PMA-1A	AP MRM
PMA-2	AP MRM
Type 72	AP MRM
MK2	Inert AP blast mine
VS50	Inert AP blast mine
TS50	Inert AP blast mine
PMN	AP MRM
PMD-6	Inert AP box mine with simulated detonator



Figure A-5: Test Targets

3.3 Test Lane Mine Layout

All trials were conducted using the same target sequence and layout as shown in Figure A-6. The target sequence starting closest to the test lane start point is AT, PAP, PMA2, PMN, PMA1, VS50, PMD6, MK2, Type 72, and TS50. The targets were buried after the ground was cultivated by the Floating Mine Blade at Sites One and Three (the light and heavy clay sites). The sandy soil did not need to be cultivated prior to sifting. Since single lanes were used for multiple runs, it was necessary to level the sand with the rake between each run conducted by the HLS. Three, each, of the above listed targets were buried in each test lane, one per row (right, center, and left), for a total of 30 targets per lane. The targets that were placed in the right row were marked with blue paint, those in the left column were marked with yellow paint, and the ones in the center were not marked. Since the mines were not numbered, the paint helped in accounting for the targets.

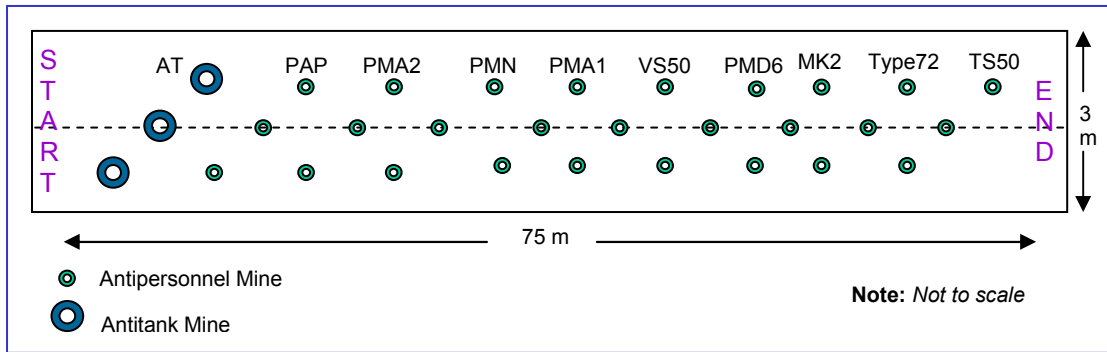

Figure A-6: Layout of Test Lane and Test Targets

3.4 Soil Sifting and Mine Clearing Tests

The mine-clearing and soil-sifting tests were conducted simultaneously to evaluate the performance and effectiveness of the Heartlands Sifter. The HLS was evaluated during a total of eighteen (18) runs on three test sites with a total of four soil conditions. A run consisted of a single pass with the sifter moving in one direction. The number of runs conducted at each site varied.

In actual demining operations, a suspected minefield would be processed by any of a variety of mechanical systems using multiple passes in various directions. To simulate this mechanical ground preparation, test targets were buried after soil cultivation, with the exception of Site Two (sandy soil) where prior ground preparation was not required. For each soil condition, the targets were buried at a greater depth with each consecutive run. This test was conducted to evaluate the effectiveness of the sifter when completing single passes in the same direction. The run time, soil moisture content, operating depth, number of cleared mines, number of activated cleared mines, and depth of the mines were recorded.

3.4.1 Soil Sifting Results

The HLS was evaluated during a total of 18 runs covering an area of 4050 m² in 183.5 minutes, for an average of 1312 m²/hr. Of the 18 runs, four runs were conducted in the cultivated heavy clay soil, four runs were in the cultivated and sifted heavy clay soil, six runs were in the sand, and four runs were in the cultivated light clay soil. Under all four conditions, the HLS moved cultivated or plowed soil and mines from the test lane to windrows without needing any major repairs.

The amount of time it took the HLS to complete a lane (75 m in length by 3 m wide) was influenced by a variety of factors. The speed of advance of the prime mover was dependent upon the soil-sifting rate of the HLS. The rate at which the HLS sifted the soils (see Table A-4) was dependent on the type of soil, the moisture content of the soil, vegetation, and how much ground preparation was conducted prior to the sifting operation.

The sifter worked best in soil with little to no vegetation. For the sifter to operate effectively in tightly packed soils, prior ground preparation would be required.

Table A-4: Soil Sifting Data

Run	% Moisture	% Moisture	% Moisture	Average Moisture (%)	Time (~minute)	Rate (~m²/min)	Average Operating Depth (cm)
Cultivated Heavy Clay Soil (FMB prepared soil)							
1	12.3	8.7	12.4	11.1	7.0	33.2	15.0
2	7.2	5.4	10.7	7.8	10.2	22.8	20.0
3	8.0	7.8	13.0	9.6	15.0	15.5	27.0
4	9.5	14.1	14.5	12.7	11.5	20.2	30.0
Cultivated and Sifted Heavy Clay (FMB and HLS prepared soil)							
1	14.7	14.3	15.3	14.8	6.0	38.8	15.0
2	9.2	11.2	10.1	10.2	4.5	51.7	20.0
3	11.8	14.7	9.1	11.6	10.5	22.1	25.0
4	10.8	10.5	11.2	10.8	11.5	20.2	30.0
Sandy Soil (No prior soil preparation, but rake between runs)							
1	1.2	.9	1.1	1.1	10.0	23	17.5
2	1.4	1.6	2.1	3.6	7.0	33.2	25.0
3	3.7	3.4	3.6	3.4	6.5	34.6	28.0
4	3.5	3.0	2.5	3.0	12.5	18.6	32.0
5	11.6	11.4	4.8	9.3	17.0	13.7	37.0
6	5.0	17.2	16.8	13.0	11.0	21.1	40.0
Cultivated Light Clay (FMB prepared soil)							
1	12.6	14.7	17.0	14.8	11.5	20.2	15.0
2	14.4	13.6	11.4	13.1	9.8	23.7	20.0
3	12.7	11.5	13.5	12.6	11.5	20.2	25.0
4	11.2	9.6	13.1	11.3	10.5	22.1	30.0
Total number of Runs		Average Moisture (%)		Total Area Covered (m²)		Total Time (minutes)	
18		9.8		4050.0		183.5	

3.4.1.1 Cultivated Heavy Clay Soil

The HLS was evaluated during four runs in cultivated heavy clay soil, covering 900m² of area in 43.7 minutes (1235 m²/hr.). The ground was damp (average of 10.3% moisture content) and consisted of thick, tightly packed clay. The soil tended to clump together even after being broken up by the FMB tines during soil preparation. The HLS dug as deep as 30cm into the cultivated ground, sifted the soil, and then deposited the larger debris (rocks and sod) along with large clumps of soil on the windrow. The windrow berms created by the HLS were as large as 60 cm tall and 100 cm wide.

Soil built up on the HLS front digging blade over the course of each run, requiring that the blade be cleaned off after each lane run.



Figure A-7:
Cultivated Test Lane



Figure A-8:
Sifted Test Lane and Berm

3.4.1.2 Cultivated and Sifted Heavy Clay Soil

The HLS was evaluated over four runs in the cultivated and sifted heavy clay and covered 900 m² of area in 32.5 minutes (1660 m²/hr). The average soil moisture content was 11.9%. The soil was prepared using the FMB and the HLS. The evaluation was conducted as the HLS processed the soil for the second time. The only significant difference in processing between the cultivated heavy clay and the cultivated and sifted heavy clay was the amount of time the HLS took to process the soils. The HLS processed the sifted soil 11.2 minutes faster than the unsifted heavy clay soil. The HLS dug as deep as 30 cm, lifting uncultivated and unsifted soil as well as sifted soil from the previous run, which resulted in large berms of dirt clumps and debris along the windrow.



**Figure A-9:
Sifted, Cultivated Lane**



**Figure A-10:
Sifted, Cultivated and Sifted Lane**

3.4.1.3 Sandy Soil

The HLS was evaluated during six runs in the sandy soil, covering 1350 m² of ground in 64 minutes (1265 m²/hr). The sandy soil was loose and damp with an average soil moisture content of 17.2%. The HLS was able to dig as deep as 40 cm. This depth is 10 cm more than the manufacturer's recommended maximum depth for the system. Soil preparation was not needed for the HLS to operate effectively in the sand. However, after each run, the rake mounted on the back of the tractor was used to level out the end-berm left by the HLS.



**Figure A-11:
HLS Operating in Sand**



**Figure A-12:
Sifted Sand Lane with End-Berm**

3.4.1.4 Cultivated Light Clay Soil with Sod

The HLS was evaluated during four runs in cultivated light clay soil (covered with sod), covering 900 m² of area in 43.3 minutes (1247 m²/hr). The average soil moisture content was 17%. The soil was prepared using the FMB. The HLS dug as deep as 30 cm. In a few places along the run, the HLS dug deeper than the FMB had during soil preparation. In these cases, the HLS blade dug up large clumps of uncultivated soil. Since the ground was covered with sod, the sod root structure tended to hold the soil in clumps. The HLS sifted the soil then

deposited the remaining dirt and sod clumps in the windrow creating berms as large as 75 cm in height and 95 cm wide.



**Figure A-13:
Cultivate Light Clay with Sod**



**Figure A-14:
HLS Sifting Light Clay and Sod**

3.4.2 Mine Clearing Results

The HLS was evaluated during a total of 18 trials in four soil conditions and cleared 97.8% (528/540) of the buried targets (see Table A-5). The HLS recovered all antitank targets and all but 12 antipersonnel targets. Of the 12 missed targets, four targets were recovered at the end of the lane in the berm and eight targets were missed due to the vehicle veering from the centerline. The sifter activated 14.8% (70/474) of antipersonnel targets that were processed (see Table A-6). These targets were 33-PMA1s, 14 PMD6s, 9 PMNs, 5 VS50s, 3 PAPs, 3 PMA2s, 2 TS50s, and one MK2. The two mine types most frequently activated (PMA1 and PMD6) were rectangular in shape and required very little pressure to activate.

Table A-5: Mine Clearance Data

Run	Depth of Targets	# Cleared Targets	# Cleared Targets Activated	Remarks
Cultivated Heavy Clay Soil (FMB prepared soil)				
1	Flush	28	6	The targets activated were the left and center PMD6s, the left and center PMA1s, the center PMN, and the right PMA2. One PAP and 1 PMN were buried in the spoil at end of run. One PMN was found on sifter under main web after 2 nd sifter run. The PMN fell back into the underside of the main web.
2	5 cm	30	2	The left PMA1 and the left TS50 were activated.
3	10 cm	30	4	All PMA1s and the center PMN were activated. Right PMN and right PMA2 safety pins were not removed.
4	15 cm	29	4	The left PAP, the center and right PMA1s, and the left PMD6 were activated. The HLS missed the left PMA2.
Cultivated and Sifted Heavy Clay (FMB and HLS prepared soil)				
1	Flush	30	4	The right and left PMD6, the center and right PMA1 mines were activated.
2	5 cm	27	1	The only target activated was the right PMA2. All PMA1 safety pins left on. Last 3 left targets (TS50, MK2 and Type72) were missed – the vehicle veered right. Conducted a 2 nd pass, cleared all targets, but the MK2 was activated underneath main web.
3	10 cm	30	3	The three targets activated were the left and right PMA1, and the left PMD6. Large spoils covered targets totally or partially.
4	15 cm	28	4	All PMA1s and the left VS50 were activated during this run. Missed the right PMN, left PAP, and hit the bottom of AT. Made a 2 nd pass. Picked up left PAP and right PMN (activated).
Sandy Soil (No prior preparation, but raked between runs)				
1	Flush	29	1	The HLS veered left and missed a right PMA1 target. The sifter activated the left PMD6.
2	5 cm	30	3	The center and right PMA1 and the center VS50 targets were activated.
3	10 cm	30	5	The center PMA2, center PMN, and all PMA1s were activated. An AT mine was caught on the cross conveyor under the center bar located above the cross conveyor.
4	15 cm	28	3	All PMA1s were activated. HLS drifted left, missed the right Type 72 and right TS 50. Conducted a 2 nd pass and picked up the TS50, but missed Type 72. It was found between tire and sifter.
5	20 cm	30	3	The center and right PMA1s and the right PMD6 were activated.
6	25 cm	30	3	The right PMA1, the center PMD6, and the center MK2 were activated. Center MK2 slipped between main and cross webs.
Cultivated Light Clay (FMB prepared soil)				
1	Flush	30	5	The center PMD6, the left and center PMN, and the left and center PMA1 were activated. Initially the cross conveyor was rotating too slowly. Its rotational speed was increased.
2	5 cm	30	9	HLS activated the right and center PMD6s, the right PMA1, the three VS50s, the center and left PAP, and the right TS50.
3	10 cm	30	5	One PMA1 fell to the right of the vehicle and was not processed to the windrow. HLS activated left PMD6, left and right PMNs, and right and center PMA1s.
4	15 cm	29	5	The PAP string caught on conveyor and the PAP flipped back into the sifted ground. Targets activated were the left PMD6, the left and right PMNs, and the center and right PMA1s.

Table A-6: Targets Activated During Each Run

Runs	AT	PAP	PMA2	PMN	PMA1	VS50	PMD6	MK2	Type 72	TS50	Total
Cultivated Heavy Clay Soil (FMB prepared soil)											
1	0	0	1	1	2	0	2	0	0	0	6
2	0	0	0	0	1	0	0	0	0	1	2
3	0	0	0	1	3	0	0	0	0	0	4
4	0	1	0	0	2	0	1	0	0	0	4
Cultivated and Sifted Heavy Clay Soil (FMB and Sifter prepared soil)											
5	0	0	0	0	2	0	2	0	0	0	4
6	0	0	1	0	0	0	0	0	0	0	1
7	0	0	0	0	2	0	1	0	0	0	3
8	0	0	0	0	3	1	0	0	0	0	4
Sandy Soil (No prior preparation, but raked between runs)											
9	0	0	0	0	0	0	1	0	0	0	1
10	0	0	0	0	2	1	0	0	0	0	3
11	0	0	1	1	3	0	0	0	0	0	5
12	0	0	0	0	3	0	0	0	0	0	3
13	0	0	0	0	2	0	1	0	0	0	3
14	0	0	0	0	1	0	1	1	0	0	3
Cultivated Light Clay (FMB prepared soil)											
15	0	0	0	2	2	0	1	0	0	0	5
16	0	2	0	0	1	3	2	0	0	1	9
17	0	0	0	2	2	0	1	0	0	0	5
18	0	0	0	2	2	0	1	0	0	0	5
Total	0	3	3	9	33	5	14	1	0	2	70

In four instances, the smaller targets (one PMN, two MK2, and one Type 72) slipped between the main sifting web and the cross conveyor. These targets were either caught underneath the main web or fell back onto the sifted ground underneath the HLS. If these were live mines, additional problems could have occurred. First, the sifted soil could have contained live mines. Second, the probability of some mines detonating could be increased due to the mines being battered as they continued to bounce in the sifting web instead of clearing the sifter.



Figure A-15: Mine on Sifter Belt



Figure A-16: Another Mine on Sifter Belt



**Figure A-17:
Mine on Cross Conveyor**



**Figure A-18:
Mine Deposited at Side of Sifter**

In both heavy and light clay soils, the HLS left large windrows, where the targets were either partially or totally reburied under the clumps of soil. For actual demining operations, another mechanical system or deminers with metal detectors will have to follow the HLS to find and remove these reburied targets from the berms. In all soil conditions, a soil bow wave formed on the front scoop during operations through which mines entering the sifter had to pass. When the dirt bow wave was removed from the sifter at the end of each lane, an end-berm was formed. Since the end berm could also contain mines, it also must be treated mechanically or by deminers with metal detectors to removes any remaining mines.



Figure A-19:
Mine Deposited in Berm



Figure A-20:
Lane End Berm from HLS Front Scoop

3.5 Tire Ground Pressure Test

While the sifter is not intended for operation in an antitank-landmine environment, there is the possibility that an antitank mine may be buried with the antipersonnel mines in a minefield. Given the possibility that the sifter may run over a landmine with its tires while operating in a minefield environment, a tire ground pressure test was conducted to determine if the HLS applied enough force, under its tires, to activate the landmines. A sixty-target test lane was laid in the sandy soil at Site Two. Test targets were either inert mines with smoke fuses or MRMs with spring-loaded fuse simulators. Each target type was buried at various depths: 0 cm/flush, 5 cm, 10 cm, 15 cm, 20 cm and 25 cm. See Figure A-21 below. The HLS traversed the lane with the blade digging into the ground while sifting. The digging depth of the blade increased as the burial depths of the targets increased. At completion of the run, the targets were examined to determine their disposition. The results are listed in Table A-7.

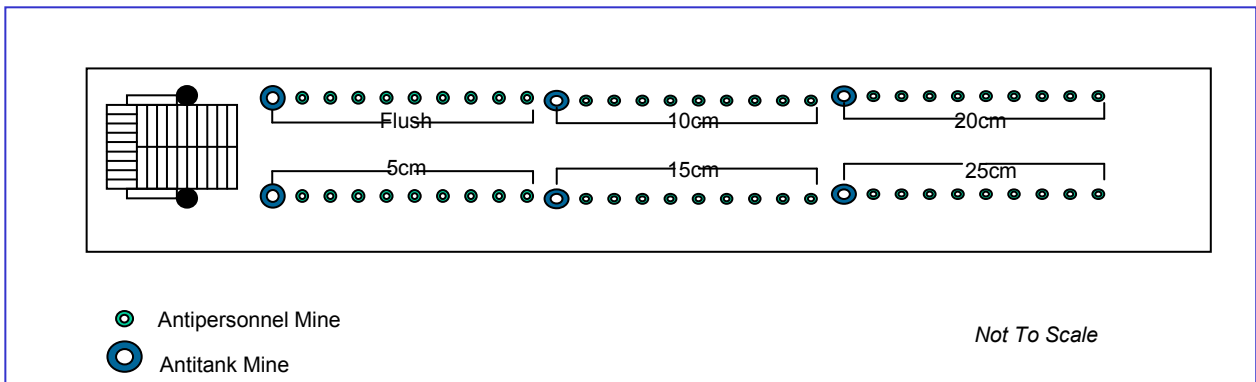

Figure A-21: Mine Layout for Pressure Test

Table A-7: Tire Ground Pressure Test Results

Target	Flush	5 cm	10 cm	15 cm	20 cm	25 cm	Target(s) Activated
AT	A	A	N	N	N	A	3
PAP	A	A	N	A	A	A	5
PMA-2	A	A	N	N	A	N	3
PMN	A	A	A	A	A	A	6
PMA-1A	A	A	A	A	A	A	6
VS50	N	N	A	A	A	A	4
PMD-6	A	A	A	N	A	A	5
MK2	A	A	A	A	A	A	6
Type 72	A	A	A	A	A	A	6
TS50	N	N	N	N	N	N	0

Note: A = Activated; N = Not activated

The HLS exerted enough ground pressure to activate 44 of 60 targets or 73% of the targets. The tires were not blast tested against antipersonnel mines to determine survivability, but based on an engineering assessment, the tires would have incurred damage requiring minor to major repair or replacement. For demining operations, the tires should be of a design that could withstand antipersonnel mine blasts with minimal resulting damage.

3.6 Mine Actuation Assessment

While no live mines were used during this test, all test targets had either smoke fuses or were MRMs with mechanical fuse simulators to provide data on how many mines would have exploded had live mines been used. The exact cause of a target's activation during the sifting test could not be determined (tumbling on the sifting web, pressure applied by the front scoop, being hit by debris in the sifter, etc.).

Based on experience gained in other tests, it is expected that the main- and cross-conveyor webs would incur some damage if live mines are activated during sifting, but the extent of the damage has yet to be determined. The results of a blast test (not conducted during this test) of the HLS against live mines would provide absolute data on the damage the HLS would incur. The pneumatic tires, as tested, are not designed to be blast-resistant and would require repair or replacement if they detonate a landmine.

3.7 Safety Evaluation

A safety assessment was conducted on operations involving the use of the HLS throughout the testing. The assessment was geared toward answering two questions: Is the HLS a safe piece of equipment for the operator to use in live minefields? And, does the HLS leave minefields ready for safe agricultural operation and/or safe living condition for the civilian populace after demining operations are complete? The HLS must clear landmines effectively while mitigating risks of injuries to the deminers. The safety evaluation is based upon the performance of the HLS throughout the duration of the test, with emphasis on the mine-clearance portion of the test.

3.7.1 Operator's Safety

Neither the HLS nor its prime mover were armored for this test, and there are no plans to armor them in the future. Even so, the HLS provides a safe means for the operator to clear landmines for the following reasons:

- The HLS would be operated by remote control (was not evaluated during this test). This would provide the operator with a safe standoff distance in the event that a mine blast occurred during HLS operations.
- Based on what is known of mine blast patterns, an antipersonnel mine activated on the sifting web would do minimal damage to the HLS if the blast occurred on the web while the web was in motion; the 2.5 cm spacing between the bars would allow the blast to vent. (However, a mine blast may cause damage to the HLS if the target were restricted from moving on the web or if the activation occurred next to the solid metal area of the HLS.)

This system was designed to be one tool in a deminer's toolbox. It is intended to be used in combination with other mechanical systems. As such, the HLS is a safe piece of equipment to operate as a follow-on system, mitigating the risk of injuries to the operator. The HLS can also be used as a quality assurance tool. However, the HLS is not recommended for use in any minefield that is suspected of containing or known to contain antitank mines.

3.7.2 Safe Land

In most cases around the world, it is very difficult to state that 100% of the landmines have been removed after a demining operation considering that the actual number of mines originally in the ground is usually unknown. The results of this test indicated that the HLS cleared 97.8% of landmines in its first pass of sifting the test areas. In most, if not all circumstances, 2.8% of mines left in the ground is not satisfactory. However, the HLS would significantly reduce the number of mines in the ground when used as one tool within a toolbox approach to demining, or with multiple applications of the HLS. Using the multiple tool method, the HLS should leave the land ready for planting and/or living.

3.8 Maintenance Evaluation

The HLS was found to be a simple system to maintain. The operator conducted daily visual inspections of the HLS to check for hydraulic leaks, bent bars on the sifting webs, and proper tire air pressure. Any debris on the sifting webs was removed prior to operating the HLS. The operator checked the sifting webs for proper rotation. Additionally, grease fittings were checked for greasing on a weekly basis.

The only damage to the HLS that required major repair occurred at the beginning of the test period, during the start of the second run. The left sprocket chain and the right main sifting web broke. The repair took about half a day once the parts arrived. The HLS performed well for the rest of the testing period.



Figure A-22: Broken Drive Chain



Figure A-23: Broken Sifting Belt

4 OBSERVATIONS AND RECOMMENDATIONS

Some of the unsifted soil, targets, and other debris brought up by the blade fell over the side of the side-plates in the area adjacent to the front scoop. It is recommended that the height of the side plates be increased or slotted bars be added onto the side plates to limit this effect.

The debris in the windrow, especially when piled high, tended to fall back into the sifted area. It is recommended that the cross conveyor be extended to the full width of the sifter.

Periodically, circular antipersonnel targets (PMN, MK2, Type 72) would slip between the main web and the cross-conveyor web and get lodged inside and underneath the top surface of the main web. It is recommended that a rubber guard or shield be mounted to the frame of the HLS at the junction of the main web and cross conveyor's web to prevent the targets from falling back into the sifted ground or underneath the web.

An antitank mine lying on its side was caught between the center bar and the cross conveyor. It is recommended that the distance between the center bar and the cross conveyor be increased.

5 SUMMARY

The sifter found 97.8% of the buried test targets during the total test.

For the most part, the HLS required only minimal repairs during the test. In loose, damp (17% soil moisture content), sandy soil the sifter did not need any ground preparation prior to operations and was able to dig and operate to a depth of 40 cm, 10 cm more than the manufacturer's recommended maximum depth. In the heavy and light clay soils, with soil moisture content as high as 17%, the sifter lifted and sifted the soil, digging as deep as 30 cm. In sod-covered soil, the sifter was able to lift, move, and sift soil and sod (including the roots). In sod-covered soil conditions, high moisture and uncultivated clay-soil conditions, the sifter

created berms of debris and non-sifted clumps of dirt in the windrow, with mines being frequently reburied underneath the dirt and debris. The berms created were up to 60 cm in height. The sifter worked best in sandy soil and soil with little to no vegetation. The HLS required prior ground preparation in tightly packed soil.

The following types of targets (a mixture of simulants and inert mines) were used during this testing: PMA1, PMA2, PMD6, PMN, PAP, Type 72, VS50, TS50, MK2, and M20 (the only antitank target used). During the mine clearing sifter tests, the HLS activated 14.8% (70/474) of antipersonnel mines and 0% (0/54) of the antitank mines. The number and type of mines activated were 33-PMA1s, 14 PMD6s, 9 PMNs, 5 VS50s, 3 PAPs and 3 PMA2, 2 TS50s and 1 MK2.

The tire ground pressure test was conducted to see if the HLS would exert enough force to activate the mines buried at various depths. Each type of mine was buried flush, 5 cm, 10 cm, 15 cm, 20 cm and 25 cm. Out of 60 mines, 45 mines (75%) were activated.

The HLS proved to be a simple system to maintain. Daily maintenance took 5-10 minutes to complete and consisted of a visual inspection of the system for hydraulic leaks and debris on the system. The left sprocket chain and the right main web were repaired during this test.

Overall the HLS could remove landmines from the ground with greater safety for the operator and at a faster pace than manual demining.

APPENDIX B
VULCAN LASER POSITIONING SYSTEM

APPENDIX B

VULCAN LASER POSITIONING SYSTEM

VULCAN LASER POSITIONING SYSTEM SPECIFICATIONS

Horizontal Operational Distance

B = distance between two transmitters in a straight line

B minimum = 15 ft

B maximum = 105 ft*

Area Coverage

Area coverage = B × B

Minimum = 15 ft × 15 ft

Maximum = 105 ft × 105 ft†

* Maximum radial distance of transmitter = 150 ft

† Area coverage may be doubled by working on both sides of the baseline, creating a maximum working area of 210 ft × 105 ft. Effective range may be increased or reduced by ambient light conditions.

System Measurements

MEASUREMENT	Dimensions inches (cm)	Weight lbs (kg)
SYSTEM		
Transmitter	4.8×4.8×7.1 (12.2×12.2×86.8)	4.9 (2.23)
Receiver	42.4×5.0×9.9 (107.7×12.7×25.1)	4.0 (1.8)

SYSTEM AND PROCEDURE DESCRIPTION

The Vulcan Laser Positioning System (VLPS), a COTS survey marking system manufactured by Arc Second, Inc., in Dulles, Virginia, was used as the primary surveying device during the Mine Clearing Cultivator and Mine Clearing Sifter testing to measure initial and final positions of the test targets. The VLPS allows very accurate and precise measurements in three axes by use of local positioning transmitters. A basic system consists of two laser transmitters that are set up in fixed positions and a receiver pole that can be placed anywhere in the range of the transmitters.

The VLPS is used to survey points in a relative frame of reference instead of an absolute frame of reference like a GPS system. After initial setup and calibration, the VLPS frame of reference can be set as desired. This is done by choosing an origin ($x = 0$, $y = 0$, $z = 0$) and then designating the direction of the x- or y-axis. The VLPS has to be reoriented every time the lasers are turned off and back on. To return to the same frame of reference, tent pegs were driven into the ground to be used as reference points (also known as snap points).

The VLPS used during this test could measure an area approximately 40 meters wide by 80 meters long. The area for the MCC/MCS test was 20 meters by 140 meters. Since the test area was larger than one VLPS's coverage, the field was split into two halves and covered by two systems (A and B). Each half was 20 meters by 70 meters (see Figure B-1).

Though the test area was covered by two VLPSs, it was imperative that location measurements of all mines in the minefield be made relative to a single starting point. To establish this chosen origin, the field was set up using transitional snap points located in the middle of the field in an area covered by both sets of transmitters. Once the VLPSs were coordinated, frame-of-reference snap points were established with each half of the field having two frame-of-reference snap points near each corner (see Figure B-1). These frame-of-reference snap points were used to relocate both systems to their original positions on subsequent testing days.

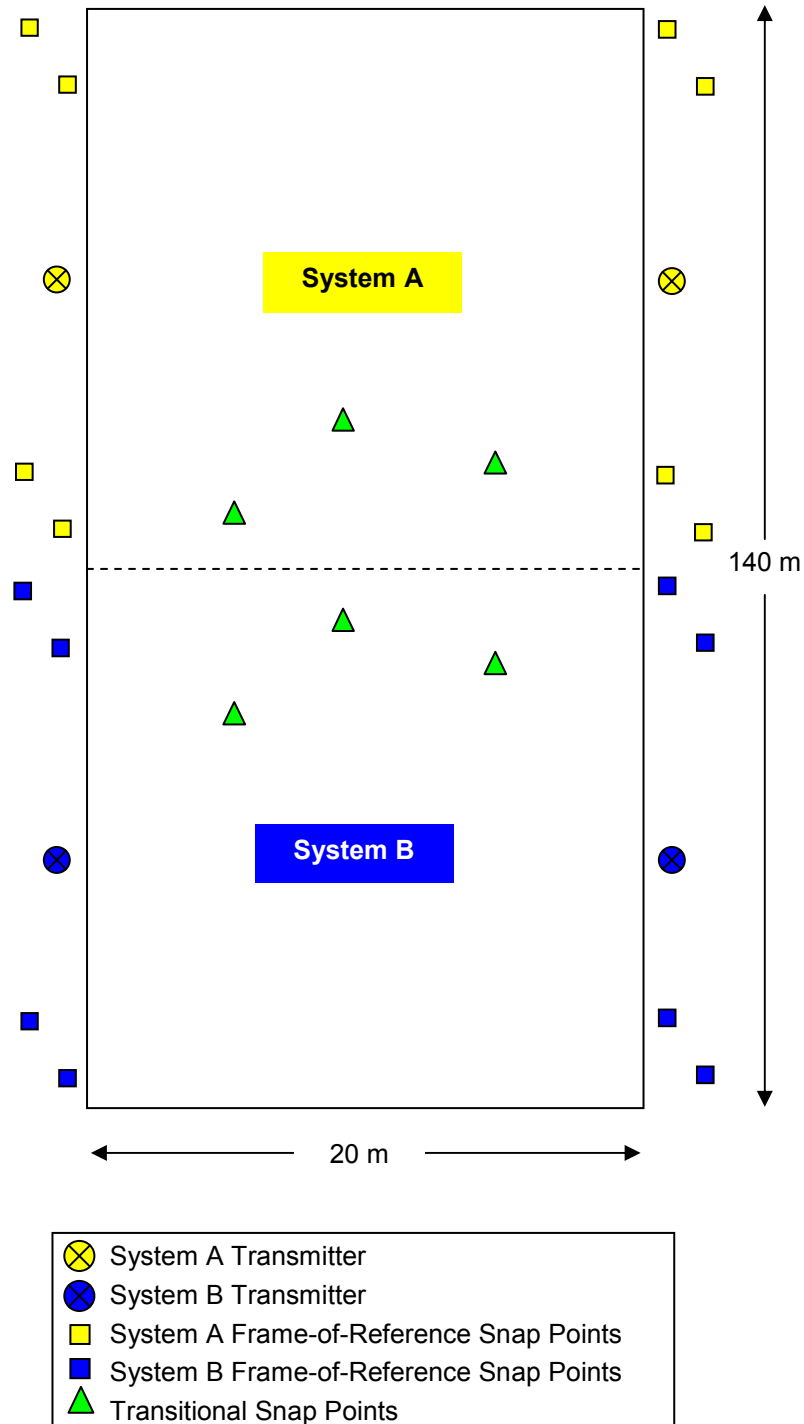

Figure B-1: VLPS Field Coverage and Snap Point Setup

BENEFITS AND LIMITATIONS OF THE VLPS

Since this test was one of the first times that the HD Team used the VLPS, several issues such as field setup, operating procedures, and data cataloging schemes had to be addressed prior to and throughout the test. The following benefits and limitations were observed during the testing period.

Benefits

- Once field setup was complete, measurements were collected quickly and accurately, eliminating the need for tape measurers stretched over long distances.
- The VLPS provided team members with the ability to locate mines that had not been processed by the MCC/MCS.

Limitations

- The VLPS's optimum coverage distance was half the length of the desired test field. Even with the field divided in half, the length of each half of the field was on the edge of the VLPS's maximum operating window. As a result, setup was more complex and time intensive than it would have been under system-ideal conditions.
- Minor equipment faults decreased productivity. For instance, one of the survey poles was broken and could only receive transmitter signals from one direction. Also, one of the PocketPC's had a loose connection that made charging difficult.

Conclusion

With proper training, planning, and equipment maintenance, the VLPS can be a valuable tool for increased accuracy and time efficiency.