

Yale University

EliScholar – A Digital Platform for Scholarly Publishing at Yale

Cowles Foundation Discussion Papers

Cowles Foundation

10-1-1974

A Theory of Money and Financial Institutions. Part XVI. Mathematical Models for a Theory of Money and Financial Institutions

Martin Shubik

Follow this and additional works at: <https://elischolar.library.yale.edu/cowles-discussion-paper-series>



Part of the [Economics Commons](#)

Recommended Citation

Shubik, Martin, "A Theory of Money and Financial Institutions. Part XVI. Mathematical Models for a Theory of Money and Financial Institutions" (1974). *Cowles Foundation Discussion Papers*. 610.
<https://elischolar.library.yale.edu/cowles-discussion-paper-series/610>

This Discussion Paper is brought to you for free and open access by the Cowles Foundation at EliScholar – A Digital Platform for Scholarly Publishing at Yale. It has been accepted for inclusion in Cowles Foundation Discussion Papers by an authorized administrator of EliScholar – A Digital Platform for Scholarly Publishing at Yale. For more information, please contact elischolar@yale.edu.

COWLES FOUNDATION FOR RESEARCH IN ECONOMICS

AT YALE UNIVERSITY

Box 2125, Yale Station
New Haven, Connecticut 06520

COWLES FOUNDATION DISCUSSION PAPER NO. 377

Note: Cowles Foundation Discussion Papers are preliminary materials circulated to stimulate discussion and critical comment. Requests for single copies of a Paper will be filled by the Cowles Foundation within the limits of the supply. References in publications to Discussion Papers (other than mere acknowledgment by a writer that he has access to such unpublished material) should be cleared with the author to protect the tentative character of these papers.

A THEORY OF MONEY AND FINANCIAL INSTITUTIONS

PART XVI

MATHEMATICAL MODELS FOR A THEORY OF MONEY AND FINANCIAL INSTITUTIONS

Martin Shubik

October 9, 1974

TABLE OF CONTENTS

	page
1. PLAYERS (TRADERS, CONSUMERS, PRODUCERS, BANKERS, ETC...)	1
2. BASIC ELEMENTARY ECONOMIC ELEMENTS	2
3. COMMODITIES, FINANCIAL INSTRUMENTS AND PREFERENCES	4
3.1. Fiat Money and Commodity Money	9
3.2. A Simplification	9
3.3. Insolvency, Bankruptcy and Feasibility	10
4. ON MONEY: COMMODITY OR FIAT	12
5. ON MARKETS AND MONEY	13
5.1. Futures Markets	13
5.2. Money, Prices and the Form of Trade	14
5.3. Markets and the Role of Money	16
5.4. Income and Sales	20
6. RULES OF THE GAME AND INFORMATION CONDITIONS	21
6.1. Aggregation Coding and Macroeconomics	22
7. SOLUTION CONCEPTS	23
7.1. Cooperative, Noncooperative and Mechanistic Solutions	24
7.2. Noncooperative Equilibria and State Strategies	27
7.3. Historical Strategies and Information	28
7.4. Behavioral Solutions and Disequilibrium	29
7.5. On Optimality and Feasibility	30

TABLE OF CONTENTS, continued

	page
8. OTHER IMPORTANT FACTORS.....	33
8.1. The Approach Adopted.....	34
8.2. The Actors.....	34
8.3. Banking.....	35
8.4. Insurance.....	36
8.5. Production.....	37
8.6. Labor.....	38
8.7. Government and Public Goods: Treasury and Taxation.....	38
8.8. Futures Markets, Contracts, Law and Accounting.....	39
9. THE STATIC MODEL.....	40
9.1. A Closed, One Period Trading Economy with Money and Credit	40
9.2. The Money Rate of Interest.....	47
10. MONEY, CREDIT AND BANKING: DYNAMICS.....	49
10.1. One Commodity and Fiat Money.....	49
10.2. One Commodity Money without Credit.....	52
10.3. Money and Banking.....	53
10.4. Productive Assets, Ownership Paper, a Stock Market and Fiat Money.....	59
11. UNCERTAINTY AND INSURANCE.....	61
11.1. Uncertainty without Insurance.....	62
11.2. Uncertainty with Insurance.....	64
12. CONCLUSIONS: MATHEMATICAL INSTITUTIONAL ECONOMICS.....	68
12.1. Some Modeling Details.....	68
12.2. Rules, Institutions and Laws.....	69
12.3. The Key Solution Concept Restated.....	69
12.4. The Central Role of Information and Communication.....	70
12.5. On Mathematical Institutional Economics.....	70

A THEORY OF MONEY AND FINANCIAL INSTITUTIONS

PART XVI

MATHEMATICAL MODELS FOR A THEORY OF MONEY AND FINANCIAL INSTITUTIONS^{*+}

by

Martin Shubik

This paper serves to lay out an approach and set of models and problems for the development of a theory of money and financial institutions. A previous paper "An Informal Guide to Some Papers on a Theory of Money and Financial Institutions,"¹ serves as a guide to the various papers and publications relevant to the type of modeling presented here. These references supply much of the discussion needed to link this approach to the economic problems which are modeled here. Several of the papers contain analyses of models and proofs that are needed. They are referred to directly. Here we concentrate on setting up the formal models together with the appropriate notation for mathematical analysis of economics controlled in disequilibrium by money and financial institutions.

1. Players (Traders, Consumers, Producers, Bankers, etc...)

In the various models players may be modeled as

- (a) Strategic "live" participants with both strategic choices and utility functions.
- (b) Mechanisms with no freedom of strategic choice and no utility functions--i.e.--as merely part of the rules.

*The research described in this paper was undertaken by grants from the Office of Naval Research and from the Ford Foundation.

⁺To be presented at the symposium on Adaptive Economics, the Mathematics Research Center, University of Wisconsin, October 21-23, 1974.

- (c) Dummies who may have utility functions but have no strategic freedom.
- (d) Nature with no utility function but strategic freedom (if probabilities are assigned to Nature's choices this amounts to making Nature into a mechanism).

2. Basic Elementary Economic Elements

In the models which follow up to as high as 8 "elementary particles" may play a role. 4 of them do not involve contracts and contingencies or time interlinkages, but 4 of them do. 4 of them do not involve more than 1 party, 4 of them involve 2 or more parties. 2 of them are "real" and 6 are paper. In a separate publication the details of these 8 items are discussed.²

The 4 elements which do not involve contracts are:

"real"	{	goods services
paper	{	fiat money ownership paper (shares, stocks, deeds, etc.)

Each of these items has associated with it a different form of paper which is a contract among 2 or more individuals and which link one period of time with another:

Associated with "goods" are "futures contracts"

Associated with "services" are "service contracts"

Associated with "fiat money" are "debt contracts"

Associated with "ownership papers" are "warrants, options,
puts and calls"

Models can be built involving far fewer than the 8 instruments. Difficulties can be separated out and the policy adapted here is to do so.

The creation of contracts as economic instruments introduces legal and societal problems in defining what to do if an economy reaches a state at which the conditions specified in a contract cannot be met. Thus methods which specify how insolvency, or failure to meet any contract, can be cured must form an integral part of the rules (thus a "mathematical institutional economics" emerges in the sense that the mathematical requirements for the complete definition of the model requires the specification of laws and institutions to fully define the process).

Given all laws then an 8x8 transition matrix linking t and $t+1$ can be described. Figure 1 shows these transitions when no failures of

	t+1	G	S	F	OP	F.C.	S.D.	D.G.	P.C.W.
t	Goods	X							
	Services								
	Fiat Money			X					
	Ownership Paper				X				
	Futures Contracts	X							
	Service Contracts		X						
	Debt Contracts			X					
	Puts, Calls, Warrants				X				

FIGURE 1

contract are encountered. It may be noted that the distinguishing feature between "goods" and "services" is the possibility for inventorying. A service at time t will not exist at time $t+1$; a good at time t is transformed, in general, to a somewhat different type of good at $t+1$.

It is possible that a fully dynamic economic system with desirable dynamic properties will only need the first four elements and one contract. The others do exist and an 8 dimensional space that can be defined appears to include as mixtures all financial instruments that exist or have existed.

3. Commodities, Financial Instruments and Preferences

In the various models, in general it will be assumed that m goods and services exist and up to 6 financial instruments exist. It may be necessary in some models to explicitly distinguish goods and services and different types of goods such as those which are public, those which are indivisible, those which do not enter directly into consumer preferences (pure production goods) and so forth. These distinctions will be made whenever they are directly relevant.

Suppose we consider an economic model with T discrete time periods. (We may later wish to consider $T \rightarrow \infty$.)

It is assumed that there are n individuals in the economy and that each individual has a completely ordered set of preferences defined on an outcome space specified below. It is further assumed that each individual's preferences can be represented by a utility function which is concave (implying risk neutrality or risk aversion unless otherwise specified). Furthermore as a modeling simplification it is assumed that the individual's utility functions are separable between time periods.

The preference structure is defined on R^{m+5} where preferences must be specified for all outcomes in the positive orthant and also for outcomes involving contracts in the negative (-) as well as the positive (+) axis.

A contract is basically a two party instrument, thus merely in order to obey simple laws of conservation we must have an accounting scheme where any contract which appears as an asset (+) on one set of accounts must appear as a liability (-) on another set of accounts. Furthermore to avoid double-counting we must take care in correctly accounting for the presence of both goods and ownership paper (such as shares) associated with these goods. In most societies the set of actions with respect to goods and ownership paper are not the same.

It is my belief that an adequate model of an economy with financial instruments and institutions must be such that accounting plays a natural and integrated role in the development of a theory of economic behavior. The models presented here have this property.

Let there be n individuals in an economy; m "real" goods and services, 2 nontime dated financial instruments (fiat money and ownership paper)* and 3 financial instruments which are contracts. For simplicity, we regard these contracts as only two party paper although three or more party paper is not uncommon. The addition of more than two parties to a contract is a complication which does not appear to be called for at this stage in model building.

*Although these forms of paper do not involve contracts between two individuals they may be regarded as forms of social contract where their laws of operation are defined in the rules of the game.

We define the utility function of individual i to be of the form

$$(1) \quad u_i = \sum_{t=1}^T \beta_i^{t-1} \varphi_i(q_{1,t}^i, q_{2,t}^i, \dots, q_{m,t}^i; f_{1,t}^i, f_{2,t}^i, c_{\Delta t}^{ij}, d_{\Delta t}^{ij}, e_{\Delta t}^{ij})$$

The notation is as follows:

- $q_{j,t}^i$ = the amount of good j held by player i at time t .
- $f_{1,t}^i$ = the amount of fiat money held by player i at time t .
- $f_{2,t}^i$ = the amount of ownership paper held by player i at time t .
- $d_{\Delta t}^{ij}$ = the amount of goods* or services contracts between i and j at the start of period t and due at the end of period t .
- $c_{\Delta t}^{ij}$ = the amount of money or debt contracts between i and j at the start of period t and due at the end of period t .
- $e_{\Delta t}^{ij}$ = the amount of warrants or puts or calls between i and j at the start of period t and due at the end of period t .

Two comments are called for. The word "amount" has been used concerning the financial instruments. The measures must be specified.

$f_{1,t}^i$ - the amount of fiat money is expressed in units of fiat money.

$f_{2,t}^i$ - the amount of ownership paper is expressed as a percentage claim on the physical assets regarded as an indivisible unit.**

$d_{\Delta t}^{ij}$ - the amount of a goods (or services) contract is expressed in terms of the quantity of goods to be delivered. In a more complex model a

*At this level by aggregating goods and services we also aggregate goods and service contracts.

**A separate detailed discussion is needed to distinguish appropriately, aggregations of divisible goods, economic institutions and indivisible goods.

"future" might involve a payment of money at time t in return for a right to pay a price p_t^* at period $t+k$ for the delivery at time $t+k$ of the quantity $q_{j,t+k}$.

$c_{\Delta t}^{ij}$ - the amount of a debt contract is expressed in the quantity of fiat money due at any period. This will involve accrual rules for multi-period debt contracts. For simplicity we begin by considering instruments which have a life only from t to $t+1$. By renegotiation new contracts can be made to connect $t+1$ to $t+2$ and so forth.

$e_{\Delta t}^{ij}$ - the amount of a warrant can be measured most simply in terms of the amount of the ownership paper to be delivered at time $t+k$. A slightly more complicated and realistic measure is the amount of money p_t^* to be paid at period $t+k$ for the delivery at time $t+k$ of an amount $f_{2,t+k}$ of the ownership paper.

The three contracts each bear two names. As noted above the names may indicate two active players. If however a banking system is constructed which has the bank or other lending or depository institution as a mechanism or part of the rules of the game one part of the balance of the contract will be out of the player set.

The notation $c_{\Delta t}^{ij}$ has been adopted so that Δt signifies that i contracts to borrow from j at the start of period t with the promise to settle at the end of t . This simplification will not cause any particular limitations when we wish to consider longer term loans, or if we wish to change the length of time periods. The tree diagram shown as

Figure 2 gives one form in which we may imagine that trade takes place.

In different specific models the details of the order of trade, production, and consumption must be spelled out.

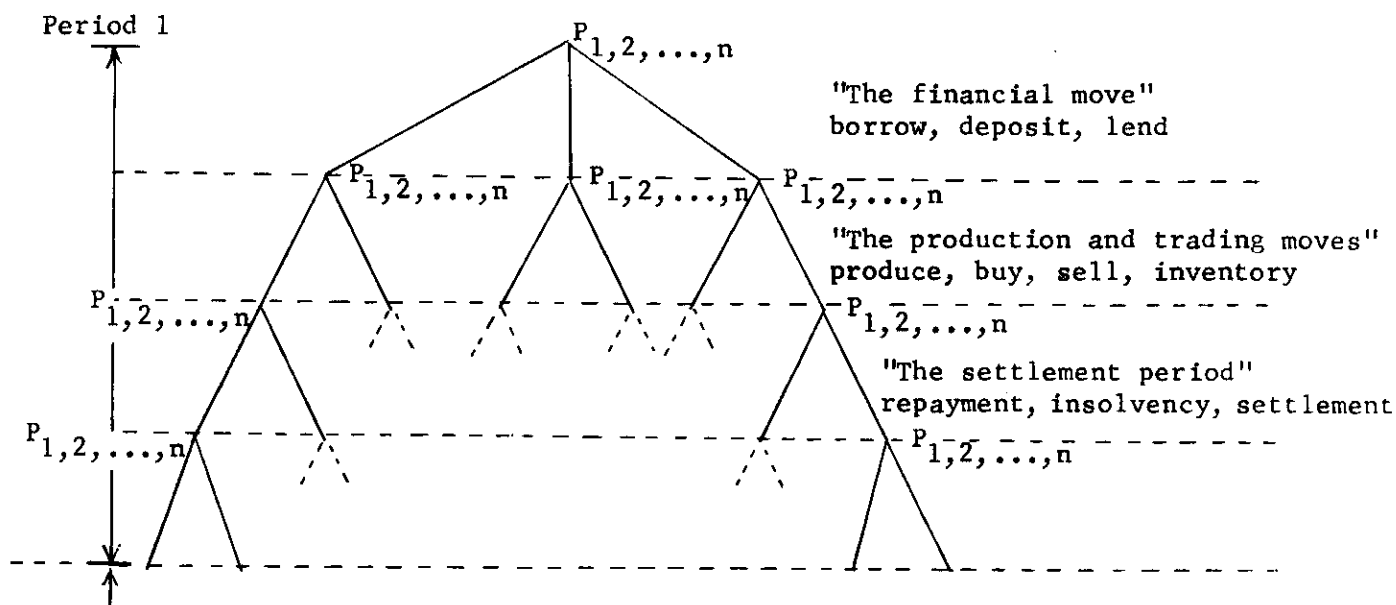

FIGURE 2

In Figure 2 the symbol $P_{1,2,\dots,n}$ means that all players move simultaneously (or at least without information of each others acts). The idea of contract reflected in this model is that of a short term financing of trade for consumption. Finance for investment might require long term finance. The only condition on the order of the moves noted above is that the financial move must be before the trading moves of the player. Settlement could be before or after consumption. The major difference in these choices are that if settlement is before consumption, unconsumed goods can be claimed if contracts are violated. If settlement is after consumption there are less goods available for use in insolvency settlements.

3.1. Fiat Money and Commodity Money

In Section 4 the strategic characterization of a money is given. Here a distinction is made between a fiat money and a commodity money in terms of its consumption worth and durability properties.

A commodity money has the strategic properties of a money, but the consumption properties of a real good. An example might be a bar of salt or brick of tea. A fiat money has the strategic properties of a money but no intrinsic consumption worth.

As a fiat money will not be defined for negative amounts (a debt instrument is not the same as fiat money--the statement "I owe \$10" means that a contract, implicitly or explicitly exists for the delivery of \$10), there is no need to consider preferences for negative amounts of money. Because debt instruments may be measured in terms of money one could try to measure both money and debt on the same axes. This creates more complications than it avoids. This should certainly be clear for commodity money. A debt instrument for 10 pounds of gold to be delivered which cannot be honored does not mean that the individual has -10 pounds of gold. It means that a contract cannot be honored and it is that which must be evaluated.

3.2. A Simplification

We leave out of the utility functions both fiat money and ownership paper. For the first set of models we consider only one contract that is the debt contract. Thus we can simplify equation (1) replacing it by:

$$(2) \quad u_i = \sum_{t=1}^T \beta_i^{t-1} \varphi_i(q_{1,t}^i, q_{2,t}^i, \dots, q_{m,t}^i; c_{\Delta t}^{i,j}) .$$

By leaving out contracts other than those which involve money for money we remove from consideration other "futures" markets which may exist in various economies. This simplification needs to be removed later.

It must be stressed that although the utility function shown in (2) involves only $m+1$ items (m goods and 1 financial instrument) there are $m+3$ items in the model (m goods fiat money, ownership paper and debt).

If the economic system functions without the failure of any contract, i.e. if all contracts are all balanced at each period then at the end of each period they will net to zero and we can in general consider that except for positions of insolvency which may lead to bankruptcy or other cures for the failure to honor contract, the utility functions depends only on the "real" commodities, i.e. it is essentially of the form:

$$(3) \quad u_i = \sum_{t=1}^T \beta_i^{t-1} \varphi_i(q_{1,t}^i, q_{2,t}^i, \dots, q_{m,t}^i, 0) .$$

3.3. Insolvency, Bankruptcy and Feasibility

When a system evolves, it is logically possible if contracts exist, that a state may be reached at which an individual is unable to honor a contract that falls due. If the contract is between two players then the double entry system will show that the time of settlement entries of $c_{\Delta t}^{ij}$ and $-c_{\Delta t}^{ij}$ which cannot be immediately cancelled. Special rules must be invoked to effect an alternative settlement.

The simplest and most nonspecific way of taking insolvency and bankruptcy into account is to define the utility functions to include contracts

which are not wiped out by the full settlement of their conditions. This somewhat avoids the task of describing precisely what happens. If we do this it is important to note that we evaluate the utilitarian worth of contracts which are not completely honored at or immediately after the violation of contract is cured, i.e. after the contract is removed from the books, destroyed and replaced by a settlement.

In actuality conditions of insolvency may lead to the replacement of one contract by another, or a series of contracts and partial payments in different forms. Eventually if an individual is not merely insolvent but cannot meet his debts even with more time to do so, bankruptcy or other procedures wipe out the contract. In the process of doing so the contract is annihilated and replaced eventually by nothing or some combination of goods, services, money and ownership paper. Going to jail or being put to death are possibilities which have arisen and they could be modeled if need be. But the attitude adopted here is that the first approximation is to include the contracts in the utility function and the second approximation is to produce a transition matrix of the variety shown in Figure 1 where however transitional probabilities must be specified for the transformation of a contract into another contract and/or partial payments in money, goods or ownership paper. The transitional probabilities are not given a priori but should emerge as a part of the solution of the game. Further discussion is needed and must be given when specific models are described.

4. On Money: Commodity or Fiat

The distinction between a "money" and other goods or services is essentially strategic and not in its characteristic as a consumption item.

The distinction between a commodity money and a fiat money is essentially in terms of its consumption worth and not its strategic properties.

In an economy with $m+1$ commodities we may select one commodity to serve as a "money" which means that we will select a model of trade in which the set of strategies of each individual with respect to the monetary commodity will be different from their strategies with respect to the other commodities.

A well known key example of a strategic requirement for a money is to consider trade in which for $m+1$ commodities there are only m markets in which each market involves an exchange of that commodity for the monetary commodity. By requiring trade in the "money," m markets can be used for trade instead of $m(m+1)/2$. The specific structure of the markets and methods of trade will influence the needs for and strategic properties of a money. This is discussed further in Section 5 on markets.

The distinction between a commodity money and a fiat money is that the former will appear as a component in the utility function and the latter will not.

A small problem is faced in the modeling of a commodity money in a multistage model. If, for example, a bar of salt is used as a commodity money, it will yield utility in consumption but not in storage. Thus although it may appear within the utility function, the amount that should

appear there is that which is consumed,* not that which is inventoried. Following this distinction through, in general, it may be shown that the use of a commodity money instead of a paper money is less efficient inasmuch as it ties up inventories of a consumable (or productive input) for strategic or trade purposes whereas paper backed by law could serve the same purpose.

5. On Markets and Money

The concept of money is intimately related with the concept of a market. It plays a key role in the simplification of market structures and in the operations of markets. It serves as a powerful information aggregation device and decentralization mechanism.

5.1. Futures Markets

It is possible to consider an economy or a game which lasts for a finite number of time periods as though it all were to take place in a single time period. In using this type of transformation (replacing a game in extensive form by a game in strategic form) it is mathematically feasible (but not necessary) to imagine that all future contingent markets exist. Arrow and Debreu use this device. Suppose that an economy has m commodities, T time periods and k different states each period (such as rain or sunshine) then we could imagine the existence of mTk markets,

*A further difficulty remains with the meaning of consumption value derived from the holding of an asset. Does the possession of a gold bar in one's bank vault yield a stream of value until it is used in trade? This is a well known problem in the modeling of stocks and flows and can be dealt with ad hoc.

one for each commodity at each time period under all contingencies. This formulation gives us the chance to describe an essentially dynamic (T period) evolutionary process as a static model of enormous size. Having done this it is possible to use well developed methods from static theory to derive certain properties of the equilibrium states of the system.

There is an alternative approach to modeling multiperiod markets this involves making the assumption that virtually no futures markets exist. It may be that in order to take care of differing subjective probabilities concerning future chance events that different futures contracts must be distinguished. This possibility however should not be considered as an a priori assumption but should emerge from the development of the theory. To start with we consider only a debt futures contract. Thus for an economy with T time periods, k different states of nature each period and m goods, we consider an enlarged market with m goods, fiat money, ownership paper and debt contracts. This gives us a dynamic system with $m+2$ markets only one of which is directly time linked.

Consideration of risk and the meaning of optimality may call for the distinction of two types of debt contract, a loan and an insurance policy. This will be considered in reference to specific models.

5.2. Money, Prices and the Form of Trade

Money is intimately related to the concept of a market but prices are not. The general equilibrium model has as a central feature the existence of prices in a closed, non-strategic, non-institutional static context. In contradistinction virtually all attempts to model oligopolistic behavior have resulted in the formulation of strategic models of trade

and production. In particular virtually all of the oligopoly models have been open models with money and goods flowing in or out with no modeling needed to preserve laws of conservation. They have been strategic (and implicitly dynamic) and in order merely to well define these models it has been necessary to specify completely the manner of trade or the markets. Thus, for example, the Cournot model utilizes quantity as a strategic variable; the models of Bertrand, Edgeworth, and Chamberlin utilize individual price naming. Other models consider both price and quantity as simultaneous variables.³ Different oligopoly models have been constructed where production variation, innovation and other economic variables have been considered.⁴

In the building of all of these models because they are strategic they call for a specification of all positions of disequilibrium as well as equilibrium. This makes it mandatory to describe the details of trade and markets.

A trained theorist might balk at the idea of having to specify a specific market mechanism. After all there are thousands of specific institutions and we might easily become lost in institutional detail. Unfortunately we do not have the alternative of leaving out this step. Leaving out the market mechanism is not a successful way to avoid institutional detail. It leaves us with an incomplete model.

The solution to the dilemma noted above which is suggested here (and previously by Shubik⁵ and Shapley and Shubik)⁶ is that we start with two or three specific models of markets, see what they imply, see what their limitations are, then branch out later to study the sensitivity of

the results to market variations). An adequate mathematical institutional economics should help us to explore the properties of the optimal design of institutions (where "optimal" is adequately defined).

The simplest model of a market for the generation of price (not necessarily efficient price) can be based on the Cournot market model. This will be clearly "unrealistic" but it provides a well defined method for both introducing a monetary mechanism and embedding a strategic model of oligopoly into a closed economy. In specifying the models we return to the special role of money.

5.3. Markets and the Role of Money

Consider an economy with $k+1$ commodities with n individuals; each individual i with an endowment $(A_1^i, A_2^i, \dots, A_{k+1}^i)$. Suppose that all individuals are required by a rule of the game to offer for sale at k warehouses all of their endowments of the first k commodities. This is illustrated in Figure 3. There will be A_j units of the j^{th} commodity for sale where $A_j = \sum_{i=1}^n A_j^i$ for $j = 1, \dots, k$.

The rules of the game require that each individual buy the quantities of the k goods he intends to consume by bidding for them in terms of the $(k+1)^{\text{st}}$ commodity. Strategically the distinction between the $(k+1)^{\text{st}}$ commodity and the others is that all trade involves a set of k two sided markets where the $(k+1)^{\text{st}}$ commodity exchanges for all of the other commodities. The essence of the "money role" in the markets is that it is the commodity that appears in all trades.

Several features are unreasonable about this model. All of them

can be relaxed or otherwise accounted for. They are

- (1) this model does not allow for some barter,
- (2) individuals must sell all their goods through the markets,
- (3) individuals must buy in money without credit available to them even if they own many assets,
- (4) individuals must bid quantities of money without being exactly sure of what they can buy.

A model with mixed markets to permit some trade through barter and partial exchange using money and anonymous markets can be defined but to begin with the ruling out of barter appears to be a reasonable simplification.

The requirement that individuals must sell all of their goods each period, even if they buy them back will be relaxed in the second model. Although the requirement that all goods are required to go through the market every time period may appear to be strange and "unreal" it has the economic and accounting benefit that income can now be measured accurately every period because all goods in the economy are monetized in the markets (capital gains and losses cannot be hidden). The mathematical benefit from this model is that the strategies of the players are relatively simple.

In some sense the contrast between the model of trade using a money and the general equilibrium model without an explicit form of money or credit is that in the first, no credit is granted to the individual even if he has many assets he wishes to sell. Whatever he buys must be paid for in cash. In contrast in the general equilibrium model the constraint

is an overall budget constraint. It is as though the individual is instantaneously credited for all of the assets he wishes to sell. The budget constraint is less restrictive than a constraint to trade using money or no more restrictive. Hence if we wish to make the model with money have less restrictive trading constraints than that imposed by the money holdings of the individuals we must introduce credit. This is done, and the nature of a credit instrument has already been noted in Section 2.

There is a curious and counterintuitive feature to the bidding mechanism which apparently has individuals assign quantities of money to markets without knowing the price of the items they are buying. I claim

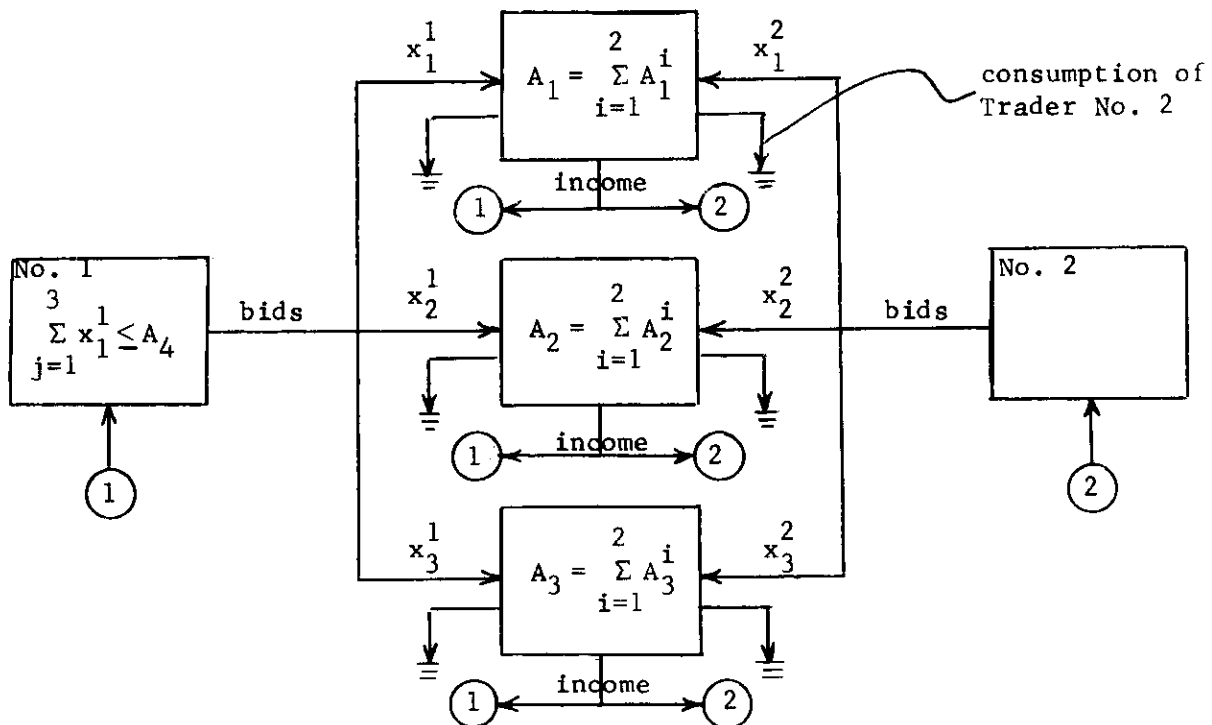

FIGURE 3

that upon reflection this is not as strange as it might seem. In particular if there are many individuals in the market and the market has a history, last period's price may serve as a guide to determining this period's allocation. There probably is no such thing as the correct model for price

formation; there are many and they differ for many institutional and special information processing or other detailed reasons. No matter how the system is modeled, if we assume that prices and quantities sold evolve out of market forces then someone has to act without the economic environment being perfectly given to him.

An alternative but more complicated model of bidding can be formalized as follows: All individuals can send to or hold back from the markets any amount they wish. Thus each, without knowledge of the actions of the others sends in his goods to the markets. Then they all bid to buy the amount for sale.

Information conditions, time lags and communication conditions are all important, but for a start we begin with the simplest situation; the decisions are as shown in Figure 4. This signifies that effectively each chooses the amounts he wishes to sell and his bidding strategies simultaneously.

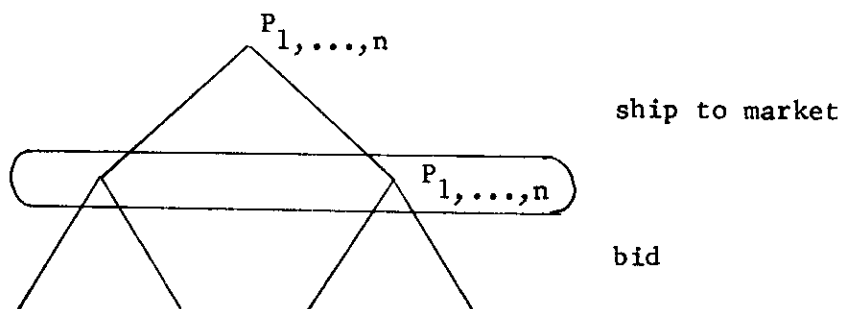

FIGURE 4

A third model in which each also names a price for his goods and the market determines a final price has been studied and used experimentally by Shubik.⁷

5.4. Income and Sales

The market mechanism sketched in Figure 3 has not yet been fully described. We have not stated how the money flows back.

Suppose we were to regard the trading economy* we are describing as a parlor game or a game which can actually be played experimentally. In order to simplify accounting and record keeping we might give each player a receipt for the commodity he delivers. Thus against the delivery of 10 tons of wheat he is given a nonnegotiable warehouse receipt. After the market has sold all the goods and price has been determined he gives his receipt to the market manager and obtains his income from the sale of his goods.

For ease in illustration we consider the first model where individuals are required to sell all of their goods. Suppose that player i allocates his spending so that he spends x_j^i on good j . Then the total expenditure on good j will be:

$$(4) \quad x_j = \sum_{i=1}^n x_j^i .$$

The total amount of good j for sale is

$$(5) \quad A_j = \sum_{i=1}^n A_j^i .$$

Thus the market price is:

$$(6) \quad p_j = x_j / A_j .$$

*Production will be introduced later.

The income derived by individual i from the sale of his goods will be:

$$(7) \quad \sum_{j=1}^k p_j A_j^i .$$

The amount of the monetary commodity in the ownership of the i^{th} individual is defined as a residual after expenditures have been made and income received.

$$(8) \quad q_{k+1}^i = A_{k+1}^i - \sum x_j^i + \sum_{j=1}^k p_j A_j^i .$$

6. Rules of the Game and Information Conditions

The monetary system and the financial institutions are the neural network of an economy. They are the carriers of much of its information content. Can this somewhat rhetorical statement be operationalized and given a mathematical structure? To a great extent the answer is yes and it lies in modeling the extensive form.

The introduction of exogenous uncertainty takes place by having "Nature" move with given probabilities. Uncertainty about the rules of the game can be introduced in a manner first used by Vickery⁸ and generalized independently by Harsanyi.⁹ Each player is considered to be one of a class of players who is chosen with given probabilities to play at the start of the game. Thus after the selection each player knows who he is, but the others are not quite sure of his identity in the sense that they have only a probability distribution on his utility function or strategic limitations or other characteristics.

In general these models may be extremely sensitive to some information conditions and not to others. There is no easy a priori test. However, many of the cases which can be generated appear to have their counterparts in economic life. For example suppose that an individual is uncertain about his income next period can he arrange his purchases so that he goes into the market before or after this uncertainty is removed? The extensive form for the first is shown in Figure 5a, and the second 5b. Nature moves second in 5a and first in 5b. The merchant capitalist who must spend even though he does not know if his ship will return safely provides an example of 5b. The full specification and import of this distinction will be made in formal models in Section 11.

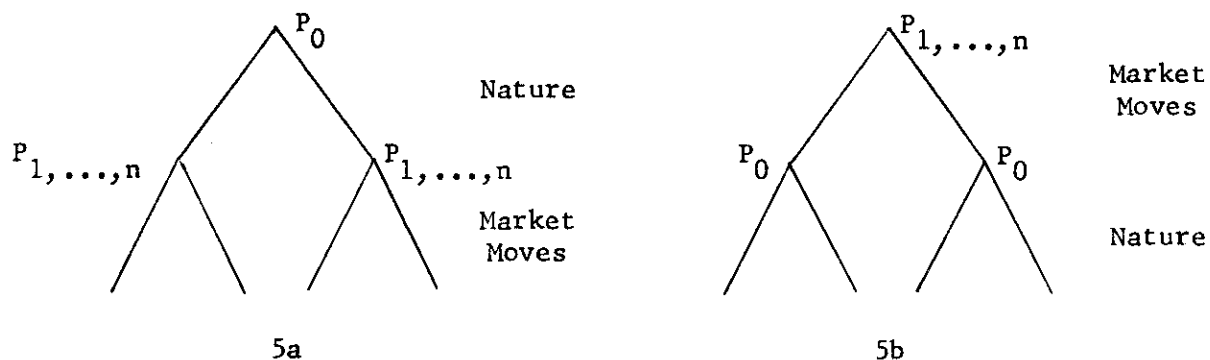

FIGURE 5

6.1. Aggregation Coding and Macroeconomics

Economic models involving groups of individuals specifying strategies frequently have moves or strategies which (unlike most abstract games) provide a natural way to aggregate information. For many economic purposes (though clearly not all) the aggregate number indicating all consumer spending may be as valuable as a detailed breakdown of the spending of each

consumer. For a bank making loans to an individual, his debt outstanding and various aggregate indicators of loanable funds may well provide an optimal information structure.

If we are studying individual behavior in mass markets where the size of the individual with respect to the whole market is small then there are some indications¹⁰ that aggregate information loses little or nothing for the individual actor.

It is my belief that macroeconomic models and theory may be derived naturally from aggregating information conditions in the microeconomic models discussed here. In general it is meaningless to talk about aggregating information because usually no natural metric is suggested which makes the addition of moves feasible. For economic games it frequently can be done.

7. Solution Concepts

So far the discussion has been limited to describing economic models and modeling markets and trading procedures without discussing how the traders behave, or should behave. We now must consider what solution criteria we wish to apply. Before turning directly to this question it should be noted that for many purposes the specification of the model alone may be regarded as the solution to the economic problem at hand, or may be a major part of the solution.

People including economists tend to attach undue importance to that which they do well. Thus there is a danger that among highly mathematically trained theorists the emphasis is placed upon the mathematical proof of theorems while the value of building the appropriate model, correctly

mathematizing it and conjecturing what the theorems might be and what aspects of the models appear to be interesting or worth exploring; are regarded as secondary. My skills are in the latter and as such I am probably biased towards unduely stressing the latter at the expense of the former. Yet neither position is sound scientifically. The skills are different and the requirements of economic analysis call for both. A failure to understand this leads to sterile economic theory full of uninteresting theorems on the one hand or taxonomies and potentially interesting descriptions without the needed depth of analysis on the other hand.

7.1. Cooperative, Noncooperative and Mechanistic Solutions

The approach adopted here will be to adapt the noncooperative equilibrium solution concept or to consider behavioral mechanisms which provide the dynamics for the multistage models. Two other alternatives could be followed. We could consider an expressly cooperative approach as has been exemplified in the solutions of the core¹¹ or the value.¹² In order to do this we would need to cast the models in coalitional form. This may be worth doing, although it must be noted that because of the presence of market mechanisms* which introduce an interconnection among the traders, the c-game property of the characteristic function¹³ is destroyed, i.e. it makes the characteristic function or coalitional representation of the game less trustworthy as an adequate reflection of the underlying economic structure.

*Which are not present in the models of trade as barter or direct exchange.

The reasons for not following the cooperative solutions at this point are several.

- (1) With markets the characteristic function or other coalitional forms of representation are hard to justify.
- (2) The very essence of the role of money and financial institutions appears to lie in the dynamics and the cooperative representations of the economy viewed as a game do not reflect this well.
- (3) The implicit or explicit assumption in cooperative models that the solution is constrained to be Pareto optimal is too strong. We should hope to deduce rather than assume optimality.

In particular it is my belief that one of the prime roles of the rules or laws for the operation of an economy with contracts is to achieve quasi-cooperation in a system which can be described as behavioristically noncooperative. But the system design provides for self policing which enables optimal outcomes to be achieved without the necessity for particularly high levels of cooperation or communication.

Another alternative to considering cooperative solutions is to try to utilize the price system model of Walras as developed by Arrow, Debreu and others in a direct extension. It is my belief that although this approach may yield some results, it is an inadequate approach for several reasons.

- (1) It is nonstrategic. Individuals are assumed to have no strategic freedom (even to commit errors).

- (2) It provides an inadequate model with which to introduce non-symmetric information conditions.
- (3) It does not provide a natural model for intermixing oligopolistic and purely competitive sectors.
- (4) It fails to meet a key test of modeling. If we try to describe a competitive market as a game to be played there is no unique way to do so. The model is insufficiently defined (as Arrow and Debreu discovered in their attempt)^{14,15}. The lack of definition hinges upon whether prices are meant to be assumed or deduced from the model.

It is conjectured here that all of the results which can be obtained by using variants of the Walrasian models can be obtained by using a non-cooperative solution concept and studying an appropriately defined limiting behavior. This solution concept however and the models to which it applies do not suffer from the weaknesses of the competitive price system models. They yield results for nonsymmetric information and for mixed competitive or oligopolistic markets.

It is my belief that the attempts to modify the competitive equilibrium Walrasian model to account for monetary, financial and informational phenomena are not unlike the attempts to modify the Ptolemaic model in astronomy. It may conceivably be done, but a parsimonious explanation lies in going to a different model.

In the remaining discussion we confine our attention to the noncooperative or to behavioral solutions.

7.2. Noncooperative Equilibria and State Strategies

The concept of a noncooperative equilibrium solution to an economic problem was first introduced by Cournot.¹⁶ The general definition is due to Nash.¹⁷ Suppose that we have a game in extensive form where at various points in the game tree at which all players have perfect information, i.e. at which they can identify exactly where they are. At each of these points the game can be partitioned into a set of subgames. A perfect equilibrium point is in equilibrium in all subgames.¹⁸ Much of the work in control theory and dynamic games utilizes a solution concept close to that of a perfect noncooperative equilibrium.

Paradoxically although the concept of a perfect equilibrium appears to be associated with relatively high levels of information, the control theory approach apparently depends upon a somewhat parsimonious state description and essentially aggregated information. This appears to be closely linked to the remarks made in 6.1 on aggregation and macroeconomic models.

In general, to start with, when we discuss solutions our attention is first focussed upon perfect equilibria. It should however be noted that a perfect equilibrium is not necessarily the same as a stationary state equilibrium. Individuals frequently talk about a stationary state when they have in mind a special model (such as a simple matrix game or a trading economy) which is repeatedly played over many periods. A great amount of confusion can arise from a failure to recognize differences in the definitions of commonly used phrases. In order to avoid the confusion here I merely note that the concept of a stationary state equilibrium is not rigorously defined until it is needed.

Suppose we were to consider the possibility of an economy that is constantly under the influence of exogenous random events (as economists do not--and probably should not--try to include in their models all aspects of human affairs such as the social, political and psychological factors these could be considered as supplying a random exogenous influence). Then our interest in economic dynamics might be in the study of systems which tend towards an equilibrium even though they may never reach an equilibrium. Our prime concern may be with paths of adjustment and movement in disequilibrium states. These distinctions, however, must be made clear in the investigation of specific models.

7.3. Historical Strategies and Information

A game which is solved for its perfect equilibrium points may also possess other equilibrium points. These other equilibria will arise from strategies which utilize more information or "history" about the previous progress of the game than do the strategies which give the perfect equilibria. The strategies needed for a perfect equilibrium are state strategies, in the sense that they depend only upon knowing where you are, not how you arrived at that position. A historical strategy makes use of information concerning the path to a position in the game. The distinction has been made in detail elsewhere and simple examples have been given.¹⁹

A simple verbal example may at least help to describe the difference and to suggest that for different economic problems either state or historical strategies may be relevant. One policy on which loans can be made is to lend to only those who currently have assets worth considerably more

than the loans. This requires little information about the individuals in order to give the lender a certain level of security. A different lending policy might be to lend based upon information concerning the past history of the individual in repaying debts. This may require considerably more information.

7.4. Behavioral Solutions and Disequilibrium

Both the noncooperative and competitive price system solutions can be regarded as special cases of a broader class of updating mechanisms which are based upon behavioral considerations which may involve more than mere maximization. For example we might wish to consider myopic behavior in which the individual forecasts future change from the immediate past and tries to maximize immediate revenues based on this information.

It is easy to specify myriads of ad hoc system updating rules which invoke no maximization operators whatsoever. It is however not so easy to offer either empirical or normative justification for most of them.

The importance of considering behavioral mechanisms is nevertheless two fold. First they provide a class of solution concepts which may be considerably easier to solve for than say a competitive equilibrium (if it exists) or a noncooperative equilibrium. Second they tend, by their very formulation, to lay their stress on process rather than equilibrium. They provide laws of motion for the system rather than seek ways to down-play dynamics and disequilibrium.

A symptom of the difference between a behavioral approach and one say, involving an equilibrium model is given by the use of forward updating

methods for generating the solution or time path of behavior and the use of backward induction. For example a common technique used for solving finite stage dynamic programs is to start at the last period and work backwards.

Attempts by economists to describe a price system dynamics by introducing excess supply or demand functions and then defining the movement of prices as depending upon the size of the gap in supply or demand can be regarded as attempts to replace the originally formulated optimization problem by a dynamically formulated behavioral system. It is my opinion that such an approach might be successful if the economic models included trade in financial instruments and had the financial system modeled together with the physical economic system in such a way that many of the feedbacks, controls and adjustments took place through the financial (or a central planning) mechanism. Without such a modification it appears to me that economic models whose dynamics derive from perceived lack of balance in the goods and services sectors alone are not adequate models of any economy.

7.5. On Optimality and Feasibility

There is considerable confusion in the discussion of optimality and feasibility by economists and others. This confusion arises for several considerably different reasons.

- (1) Can long term preferences be defined?
- (2) Can the Pareto set be defined in the presence of uncertainty?
- (3) How does market structure influence feasibility?
- (4) How do differing levels of information influence the perception of optimality?

The first and possibly most profound level at which disagreement might appear between the economists and others is that the assumption frequently made by the economist that it is meaningful to consider that an individual might look at his welfare in terms of a preference ordering over both current and future events is unreasonable. It may be argued that it is far more reasonable to assume that individuals update their preferences.

Although I am much more sympathetic to the behavioral point of view as providing a better overall model of man, I nevertheless am willing to support the economists' view that as a first approximation in application to some economic problems the assumption of the existence of preferences is a useful place to start.

Once we have accepted the existence of a preference ordering, the existence of a utility function defined up to a linear transformation appears to me to be clearly a natural next step. Arrow and Debreu offer the alternative which involves an enormous expansion of the set of outcomes. This particular expansion, while logically sound appears to me to be unsatisfactory as a method of modeling. Financial instruments exist specifically for the purpose to enable individuals to avoid having to deal with myraids of futures markets. Virtually all of the evidence from both behavior in general and economic markets in particular goes against a vast proliferation of futures trading.

The skilled economic theorist when confronted with evidence to the contrary may say that the real world contains "frictions" which do away with many of the futures markets. This observation may well be valid, but

the essence of a good approximation is that even though it is a simplification of reality it is still close to it. For this reason it is my belief that an adequate theory should have very few futures contracts rather than enormous numbers. As noted in Section 2 I believe that no more than 4 basic types of contracts are needed and (as noted in 3.2) a great deal can be developed allowing only one type of futures contract.

As has been observed in Section 3 we will assume the existence of utility functions. If we do so then optimality of a state can be defined in the utility or payoff space R^n as being on the Pareto optimal surface or "northeast" boundary of the feasible set of outcomes.

A set of outcomes which are feasible and optimal in one economic model may no longer be feasible in another closely related model. Thus for example, if we consider a model of exchange with no transactions costs and no constraints on trade we may be able to define a Pareto optimal set of outcomes all of which are feasible; if we compare this model with the one which has transactions costs the Pareto optimal set of the latter will be contained within the former because certain outcomes are no longer feasible. An easy and dangerous error which can be committed is to talk about the Pareto optimal set achievable in an economy with transactions costs as not being really optimal just because it does not coincide with the set that can be achieved if transactions costs were not a fact of life. This is about as meaningful as saying that the Pareto set in an economy in which there are costs to the production of steel is not "really Pareto optimal" because they are contained in the set for an economy where steel production is costless.

The presence of specific market structures or the absence of various futures markets may all impose limits on the feasibility of certain exchanges, hence may change the Pareto optimal set. It may well be useful to compare the Pareto optimal sets achievable in the various market models with the utopian model with all futures markets and no transactions costs. This may help us to derive a measure of the costs and worth of market organization and information.

It is technically feasible to define a game with incomplete information to solve it for its equilibrium points and to examine them in relation to the noncooperative equilibria of a game with complete information. In this manner a value for information can be established. However so far no general methods or results concerning the economic worth of information exists. We do not pursue this problem further at this time.

8. Other Important Factors*

The development of an adequate economic dynamics which reflects both the physical and the information flow processes of a society is an exercise in mathematical institutional economics. The institutions are the carriers of the information, control and financial processes. It is easy to make this observation, but it is difficult to go from such an observation to a parsimonious description which does not become bogged down in institutional detail.

*For those directly interested in the models, this section could be skimmed or skipped on first reading.

8.1. The Approach Adopted

In order to avoid the considerable confusion which might arise in trying to handle too many features of the financial and information system simultaneously the approach adopted here is to construct a series of relatively specialized, oversimplified and "unrealistic" models in order to cope with the difficulties, one at a time, or at least not more than a few at a time.

The remaining parts of this section are devoted to sketching several of the more important factors which need to be investigated separately when possible.

8.2. The Actors

It is argued here (and elsewhere)²⁰ that the description of an economy may, for many economic purposes, require the explicit introduction of several different types of economic agents or actors. In particular for many economic questions it is my belief that the following types need to be characterized separately. They are the:

- (a) consumers,
 - (b) entrepreneurs,
 - (c) bureaucrats and administrators,
 - (d) financial agents and evaluators,
- and
- (e) politicians.

Depending upon the question at hand there are several different ways in which each of these agents might be modeled using the categories suggested in Section 1, or even constructing elaborate behavioral models.

In the Arrow-Debreu world there is really only one actor--the consumer-trader and possibly another shadowy actor--mechanism called the producer. This does not appear to provide a sufficient disaggregation to characterize the information processing and evaluation aspects of an economic system.

8.3. Banking

In several of the models being developed, the need for banking arises extremely naturally from considerations of Pareto optimality in a noncooperative game. However different functions for banking may emerge which call for the construction of several differentiated institutions. In particular we may wish to distinguish

- (a) Internal Commercial Banking where any player can be a banker and (i) the lender cannot "create money," i.e. lend more than the amount of fiat he has on hand; (ii) the lender can create money.
- (b) Internal But Differentiated Commercial Banking where only a distinguished class of players can be bankers who have strategic options not available to others.
- (c) External Commercial Banking where the bank is either a mechanism or a special player with constraints or special rules concerning its use of banking profits and the role of the conservation of money and debt instruments.
- (d) Central Banking where there is a banker's bank which is a mechanism or special player with a special goal and distinguished rules of operation which enable it to take actions that other bankers cannot take. In particular considerable care must be

taken in describing the role of the central bank in the issue of fiat money.

- (e) Investment Banking which can be (i) internal or (ii) external to the system (such as part of the government) where the stress is on risk evaluation and perception of the worth of new projects.
- (f) International Banking poses a completely new set of problems involving the interrelationship between different fiat monies and individual nations as players. These problems are not discussed further in this paper.

In all of the above instances bank failure and various contract violation rules must be specified.

8.4. Insurance

Insurance also cannot be treated completely monolithically. The distinctions which are needed must cover the insurance company as

- (i) a nondistinguished private player
- (ii) a distinguished private player
- (iii) an external player (or mechanism).

A further distinction must be made concerning

- (i) noncorrelated events (auto accidents)
- and
- (ii) highly correlated events (plague, natural disaster).

Furthermore the role of insurers as risk evaluators must be reflected in the models. As with a full description of the banking function, so for the insurance function the rules concerning insurance company failure, #

other failures to meet contractual obligations, rules concerning reinsurance and rules describing the role of government must be specified in order to provide a sufficient operational definition of the system.

8.5. Production

Production must be modeled as a time consuming sequential process. There are obviously myriads of different partially parallel, partially sequential processes which are employed. Any cross section view of the economy gives an apparently simultaneous view of the activities involved in production. Thus at any point in time, some firms are hiring labor, others are buying raw materials, others are running the production lines and still others are shipping finished goods, or warehousing or stocking retailers.

The firm as an institution is an embodiment of the organization and information required to be the carrier of a production process. It is desirable to be able to distinguish the speed with which a firm can be created or destroyed as contrasted with the speed with which production can take place given the existence of the firm. An economy with institutions is a nonconservative system. Reversing the conditions which caused bankruptcy does not cause "unbankruptcy."

There are many ad hoc factors which must be accounted for in the modeling of production in time. Not the least of which is that capital goods of long duration provide "hostages" or security in the market for loans. This preliminary and abbreviated discussion is given only to call attention to the need for treating production as a separate and important

factor in the development of adequate microeconomic models. In particular it is stressed that the roles of assets, production and financing are closely interlinked.

8.6. Labor

Labor must be treated as a distinguished service, if for no other reason than for the empirical and conceptual difficulties encountered in trying to provide a satisfactory characterization of it as both a production and consumption input.

Frequently a good indication of the closeness of fit between economic theory and reality lies in the correspondence between the accounting schemes in theory and fact. The myriads of ways in which labor productivity can be concealed, unemployment disguised and quality of labor varied indicate that there are deep difficulties in describing and accounting for this factor which differ from all other factors.

8.7. Government and Public Goods; Treasury and Taxation

Modern governments work through direct planning and physical controls or through financial instruments. The interlinkage between micro and macroeconomics must come not merely in information aggregation as noted in 6.1, but also in the introduction of governmental institutions and public goods as part of the overall structure.

There are many types of public goods (as has been noted elsewhere). However as a first cut the simplest model might consist of government as a mechanism with an exogenously given strategy or utility function which involves the raising of funds to provide for a supply of public goods.

For even a simple model to have the property of computability or to be playable as a game it is necessary to specify the treasury, public financing and taxation mechanism no matter how elementary it may be. This type of model is not investigated further here.

8.8. Futures Markets, Contracts, Law and Accounting

In Section 2 it was suggested that at most 4 contracts are needed to provide time links for a dynamic economy which trades primarily in spot markets. At this point a stress on a feature in modeling is made. A criterion for the measure of success in modeling an economy with financial instruments and institutions should be how naturally do the models complement and fit in with those provided by law and accounting. Economics is not an all-encompassing discipline. The depth of description and analysis obtained in one area is invariably bought at the expense of gross simplification and the ignoring of detail elsewhere. Unless one has a mystic faith in an all-encompassing grand socio-political-economic model which is going to answer simultaneously all questions concerning society, the polity and the economy, it is probably more reasonable to settle for models with exogenous features where inputs which need more detailed description and explanation based on other disciplines are not claimed to be explained.

The legal knowledge displayed here is slight and the handling of key concepts such as property rights and contracts is rudimentary. However more concern for these factors is given than is usual in most of economic theorizing. The full detail of legal questions concerning property rights and contracts is not immediately germane to the models at hand and the

projected analysis; nevertheless the connection between the law and the economic institutions and instruments needed to run an economy, is important and should be clearly identifiable in the economic models.

Economic control and equity in a free enterprise or in a centrally controlled economy depend delicately upon the accuracy and quality of economic accounting. The imperfections in all systems are clear today in the uses of myriads of tax shelters in free enterprise economies and in concealment of stocks, pricing distortions and accounting failures in all bureaucratic systems, whether they are privately run or part of the governmental structure.

The explicit introduction of financial instruments into the models of microeconomic theory provides an opportunity for achieving a closer integration of accounting and economics and a closer investigation of the underlying basic principles of both.

9. The Static Model

In this and the remaining sections of this paper, discussion and commentary on the motivation for the type of models advocated in this paper is kept to a minimum. The emphasis is placed upon the construction and definition of a set of mathematical models whose analysis may help to justify the approach described above.

9.1. A Closed, One Period Trading Economy with Money and Credit

Let there be n individual traders (denoted by $i = 1, 2, \dots, n$).

There are $m+1$ commodities. The $m+1^{\text{st}}$ commodity is distinguished as a money (see Section 4).

The distinction between a commodity money and a fiat or paper money may be made later by including or excluding the $m+1^{\text{st}}$ commodity as an argument in the utility functions of the traders.

There is one debt contract which is for money obtained at the start of trade to be repaid before consumption but after trade has taken place.

There is one distinguished "player" or $n+1^{\text{st}}$ player which is a mechanism known as a "bank," which may extend credit or accept deposits at a zero rate of interest.

Each trader i has a utility function or payoff function evaluated at the point of consumption, i.e. after trade and the settlement of contracts has taken place. This function has $m+2$ arguments, one for each commodity and one for the debt contract ($m+1$ arguments if the money is fiat). The indifference maps for each trader are defined on the non-negative orthant of the Euclidian space R^{m+2} for all components except the $m+2^{\text{nd}}$ dimension (the debt contracts). For this dimension both the positive and negative domain must be included to account for a final position which has some contracts which have not been settled (and hence may appear as negative on some accounts and positive on other accounts).

Let the initial amount of commodity j held by individual i be A_j^i and the final amount q_j^i .

The initial amount of credit held by all individuals is assumed to be zero. After the financial settlement after the market the amount of credit held will once more be zero unless it is not feasible to settle all accounts. In which case the worth of the resolution or "cure" for this state must be reflected in the utility functions.

Let the amount that i borrows from or deposits in the bank be $c_{\Delta t}^{i,n+1}$. It is important to note that because the bank has a nonsymmetric role in the game its "name" $(n+1)$ is always one of the two names that appear on the credit instrument. Borrowing or depositing takes place between an individual and the bank and not among individuals. It is easy to argue that sometimes individuals lend each other money; but here the argument is that as an approximation for what may go on in a modern economy it is not bad to consider the credit system as going through the bank.

Let the amount of credit held by individual i after settlement be $c^{i,n+1}$. The method for calculating this amount will be specified later.

Each trader attempts to maximize his payoff:

$$(9) \quad \varphi_i(q_1^i, \dots, q_m^i, q_{m+1}^i, c^{i,n+1}) ; \text{ where } q_j^i \geq 0 .$$

The strategic choices have not yet been specified.

Information Conditions and Extensive Form

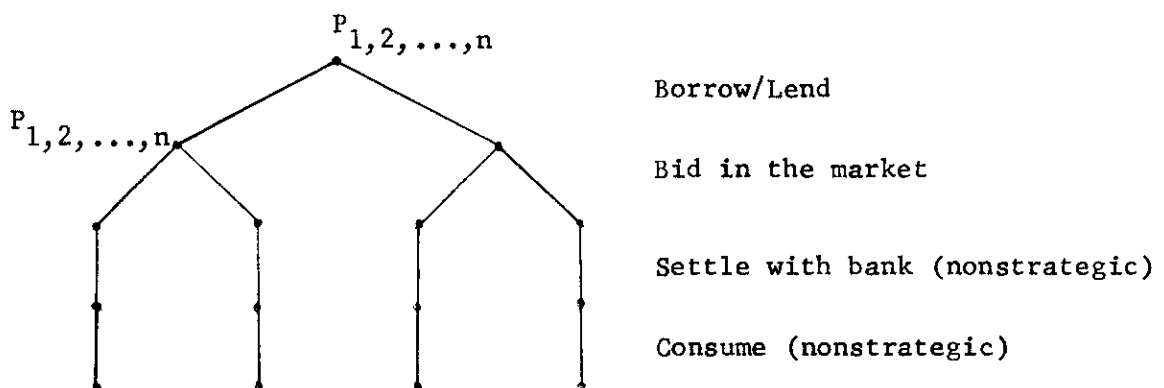

FIGURE 6

Figure 6 (see also Figure 2) is a modified game tree where it is assumed that each individual takes his financial move (borrowing and lending) and his market move (bidding, spending, selling) without being informed of the actions of the others. After these strategic moves, two "automatic" moves take place. Debt contracts are settled and then consumption takes place.

As we are attempting to provide a completely well defined mathematical structure the assumptions concerning knowledge of the rules of the game must be made explicit. It is assumed that all individuals know their own preferences and know the preferences of all others. For the type of solution (a noncooperative equilibrium) first examined here it appears that the solution will be relatively insensitive to modifications of this assumption. This may not be so in a dynamic context.

The linkage of behavioral approaches and more traditional economic approaches come quite clearly in the information and knowledge assumptions made. Much of the description of mass economic behavior appears to imply low information conditions but this may not be made explicit in the economic theory formulations (such as the Arrow-Debreu treatment of general equilibrium) which essentially finesse having to make their assumptions explicit concerning knowledge of the rules of the game.

The Market Structure and Ownership

In Section 5 we have already discussed the need to completely specify the market mechanism. Shubik,⁵ Shapley,²¹ and Shapley and Shubik⁶ have considered the simplest model with all nonmonetary goods offered for sale. This model is specified below and has been studied and solved in the papers referred to above. There are also several variants of a slightly

more complicated nature in which each individual simultaneously is required to decide how much to offer to the market, what to borrow and what to bid.

Model 1a. Quantity Strategy--No Credit

There are n traders and each trader tries to maximize his payoff (given in equation (9)) where a strategy for a trader i is an allocation of money or a vector of m dimensions $(x_1^i, x_2^i, \dots, x_m^i)$ such that:

$$(10) \quad \sum_{j=1}^m x_j^i \leq A_{m+1}^i \quad \text{and} \quad x_j^i \geq 0 .$$

The amount of good j trader i will obtain is given by

$$(11) \quad q_j^i = \frac{x_j^i}{x_j} A_j \quad \text{or} \quad q_j^i = 0 \quad \text{if} \quad x_j = 0 .$$

where $x_j = \sum_{k=1}^n x_j^k$ and $A_j = \sum_{k=1}^n A_j^k$.

The amount of money trader i will have at the end of the period is:

$$(12) \quad q_{m+1}^i = A_{m+1}^i - \sum_{j=1}^m x_j^i + \sum_{j=1}^m p_j A_j^i$$

where $p_j = x_j / A_j$. Thus we can formulate the first noncooperative game as:

$$(13) \quad \underset{x^i}{\text{maximize}} \quad \varphi_i \left(\frac{x_1^i A_1}{x_1}, \frac{x_2^i A_2}{x_2}, \dots, \frac{x_m^i A_m}{x_m}; A_{m+1}^i - \sum_{j=1}^m x_j^i + \sum_{j=1}^m p_j A_j^i \right) \quad i = 1, 2, \dots, n$$

where $x^i = \sum_{j=1}^m x_j^i$.

It has been shown that a noncooperative equilibrium exists for this model if there are at least two players who have positive utility for any good.

Replication

Replace each trader of type i by k traders of the same type (i.e. identical traders). Now consider a new noncooperative game with kn traders analogous to the game shown in (13) with n traders. It has been shown that if there is "enough" money held by all individuals then there will be a noncooperative equilibrium point which "approaches" the competitive equilibrium in the sense that in the appropriate metric it is closer for successively larger replications.

If there is not "enough" money the above is not true. The shortage of money stops trade that would have been advantageous otherwise.

Fiat Money

When the money is assumed to be fiat the $m+1^{\text{st}}$ component in the utility functions drops out. The money is used for trade, but becomes worthless after trade. The meaning of "enough" money changes in this case. There is always enough as the system is homogeneous of order 0. The coincidence of the noncooperative equilibrium and the competitive equilibrium will depend upon the ratios of monetary holdings.*

*There may be more than one competitive equilibrium in the unconstrained system; however it should be noted that the introduction of fiat money appears to offer a way for selecting among these equilibria.

If the ratios are appropriate the coincidence of the competitive equilibrium and the noncooperative equilibrium is immediate and does not require more than two traders of each type (this is not true for a market with more complex strategies where individuals do not have to offer all for sale).

Model 1b. Quantity Strategy and Credit

The simplest modification of Model 1a which reflects the role of credit is to relax condition (10). An individual is permitted to "spend more money" than he has. A way in which this can be stated more precisely is that in this model, with the permission of the bank he can jointly create a credit instrument which will be accepted at par with money when used in trade. The amount of bank money or debt created between an individual and the bank is:

$$(14) \quad c_{\Delta t}^{i,n+1} = A_{m+1}^i - x^i .$$

If the amount defined by (14) is negative the trader is a depositor in (or lender to) the bank. As no interest payment is assumed in this model depositing and hoarding is not distinguished.

After trade has taken place it is assumed that debt contracts must be settled. The method is as follows: each individual calculates the sum $q_{m+1}^i - c_{\Delta t}^{i,n+1}$. If this is positive he is solvent and his payoff is:

$$(15) \quad \varphi_i(q_1^i, q_2^i, \dots, q_m^i; q_{m+1}^i - c_{\Delta t}^{i,n+1}, 0) . *$$

*There is a problem with this formulation inasmuch as we have implicitly assumed that the bank always redeems its debt instruments for commodity money.

If the sum is negative define $c^{i,n+1} = q_{m+1}^i - c_{\Delta t}^{i,n+1}$ and the payoff is

$$(16) \quad \varphi_i(q_1^i, q_2^i, \dots, q_m^i; 0, c^{i,n+1}) .$$

Shapley and Shubik have shown that for this game noncooperative equilibria exist and that under replication the approach of the noncooperative equilibrium to the competitive equilibrium can be established.

In the papers referred to however the distinction between money and credit was not made as clearly as it needs to be to appreciate problems involving conservation or lack of conservation of money.

9.2. The Money Rate of Interest

Model 2. Quantity Bids, Credit and an Interest Rate

Suppose that individuals may borrow or deposit as they choose, but that there are charges associated with doing so. This game may be formulated in virtually the same way as Model 1b, except that two new parameters must be introduced:

ρ_1 - interest rate charged by bank on loans ($c_{\Delta t}^{i,n+1} > 0$)

ρ_2 - interest rate paid by bank on deposits ($c_{\Delta t}^{i,n+1} < 0$) .

At settlement each individual calculates the sum

$$(17) \quad q_{m+1}^i - c_{\Delta t}^{i,n+1}(1 + \rho_1) \quad \text{if } c_{\Delta t}^{i,n+1} > 0$$

$$(18) \quad q_{m+1}^i - c_{\Delta t}^{i,n+1}(1 + \rho_2) \quad \text{if } c_{\Delta t}^{i,n+1} < 0 .$$

(18) will always be positive, but (17) may be negative. When (17) is positive the payoff to trader i is:

$$(19) \quad \varphi(q_1^i, q_2^i, \dots, q_m^i; q_{m+1}^i - c_{\Delta t}^{i,n+1}(1 + \rho_1), 0)$$

a similar expression with ρ_2 replacing ρ_1 exists for (18). If (17) is negative then define $c^{i,n+1} = q_{m+1}^i - c_{\Delta t}^{i,n+1}(1 + \rho_1)$; the payoff is

$$(20) \quad \varphi_1(q_1^i, q_2^i, \dots, q_m^i; 0, c^{i,n+1}) .$$

Some Comments and Conjectures

This model has not yet been analyzed, however several observations may be made.

(a) For a commodity money and $\rho_1 > 0$ if any borrowing takes place which is not compensated for precisely by the appropriate amount of deposits then the system of the n traders is not conservative in commodity money. Hence we have either to postulate insolvency or bank failure to preserve conservation or to abandon conservation.

If loans exceed deposits by a ratio of ρ_2/ρ_1 the traders as a whole must lose part of the supply of commodity money to the bank. Thus the equilibrium in the system cannot be on the Pareto optimal set of the unconstrained trade model.

If deposits exceed loans by a ratio of ρ_2/ρ_1 then the bank is required to generate inputs of new commodity money at settlement.

(b) Fiat Money: Because fiat money is "just paper" or part of the rules of the game; the breaking of conservation laws on paper by the bank

does not cause the creation of real goods (even though it may change price levels in a multistage game).

10. Money, Credit and Banking: Dynamics

In this and the next section a series of models are presented, only one of which has been fully investigated. Nevertheless it provides a prototype for the others and links immediately with the static models in Section 9.

10.1. One Commodity and Fiat Money

Model 3. The Simplest Dynamic Model--Fiat Money, without Credit

An analogue to the pure trade model for many periods is one in which a perishable "manna" falls from heaven each period.

We may limit our analysis to one commodity by the simplifying (and somewhat unrealistic) device of requiring that although each individual may have an ownership claim to a fraction of the manna he does not have the opportunity to eat it directly but he must buy the good from a central warehouse. After all has been sold, the individuals obtain an income which equals their ownership claims on the money gathered by the warehouse. Thus we may define a circulation of income.

Suppose that there are n traders where each trader i has an ownership claim of α_i of the amount of consumer good available at any period,

$$\left(\sum_{i=1}^n \alpha_i = 1 \right)$$

Suppose trade takes place for T time periods and that the amount of the consumer good or manna each period is given by A_1, A_2, \dots, A_T ($A_t \geq 0$).

Let each trader i have an amount of a substance called "fiat money" γ_i to start with ($\gamma_i \geq 0$). We could normalize the total amount so that $\sum_{i=1}^n \gamma_i = 1$, although it is not necessary to do so.

Each individual i has a utility function of the form:

$$(21) \quad U_i(\tilde{q}^i) = \sum_{t=1}^T \beta_i^{t-1} \varphi_i(q_t^i) \quad i = 1, 2, \dots, n$$

where q_t^i is the amount of the consumer commodity consumed by i during period t . The φ_i are assumed to be concave, and when we wish to consider $T \rightarrow \infty$ we must assume that the U_i remain bounded.

A strategy by individual i in the subgame to be played at time t is to name an amount of money he offers to the market to buy the manna.

Let his strategy be denoted by x_t^i ($x_t = \sum_{i=1}^n x_t^i$).

Market price will be

$$(22) \quad p_t = x_t / A_t .$$

The number of units of manna he will obtain during period t is given by

$$(23) \quad q_t^i = \frac{x_t^i}{p_t} = \frac{x_t^i}{x_t} A_t \quad (q_t^i = 0 \text{ if } x_t = 0) .$$

Let C_t^i be the cash holdings of individual i at the start of time t . Then $C_1^i = \gamma_i$ and in general:

$$(24) \quad C_t^i = C_{t-1}^i - x_{t-1}^i + \alpha_i x_{t-1}^i .$$

We have the constraint that $0 \leq x_t^i \leq C_t^i$.

Figure 7 sketches the dynamic structure of the system with 2 traders.

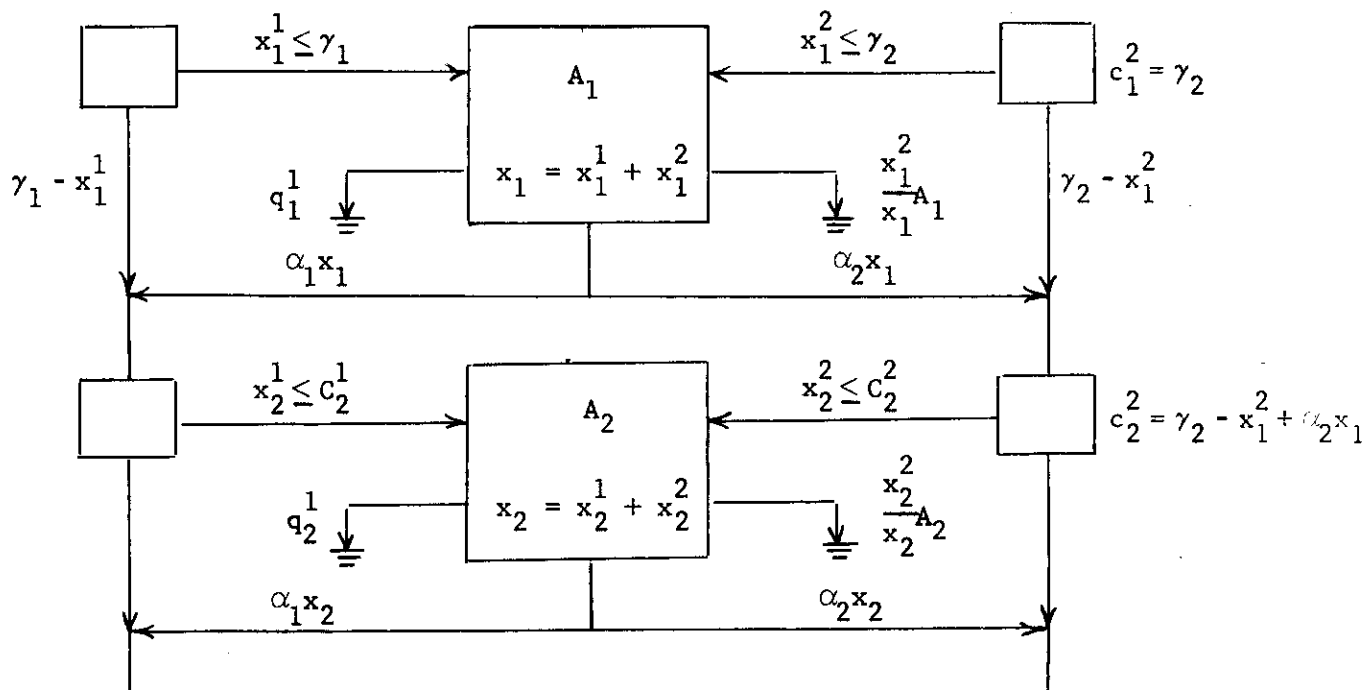

FIGURE 7

The solution concept we use is that of a perfect equilibrium or a Markovian equilibrium which has the property that the strategies are in equilibrium for every subgame.

For games with a finite horizon T , as fiat money is worthless at the end of time T we immediately know that it will all be spent at time T hence we can start a backwards induction.

An investigation of this model has been carried out by Shubik and Whitt.²² In particular for $\beta_i = \beta$, $\varphi_i(q_t^i) = q_t^i$ and $A_t = A$ a closed form solution is obtained.

(a) For β_i not all the same the noncooperative equilibrium is not a Pareto optimal point in the unconstrained model.

(b) If $\beta_i = \beta$ and $\alpha_i = \gamma_i$ then there is a Pareto optimal stationary state where all spend everything.

10.2. One Commodity Money without Credit

Model 4. Commodity Money without Credit

Let there be an exogenous supply of perishable manna A_1, A_2, \dots, A_T .

There is also a supply B^1, B^2, \dots, B^n of commodity money which can be stored indefinitely at no cost or can be consumed at any time.

The utility function for any trader is given by:

$$(25) \quad U_i(\tilde{q}_1^i, \tilde{q}_2^i) = \sum_{t=1}^T \beta_i^{t-1} \varphi_i(q_{1,t}^i, q_{2,t}^i)$$

where $q_{1,t}^i = \frac{x_t^i}{x_t} A_t$ and

$$(26) \quad 0 \leq q_{2,t}^i \leq C_t^i - x_t^i + \alpha^i x_t^i.$$

$$(27) \quad C_1^i = B^i \quad \text{and} \quad C_t^i = C_{t-1}^i - x_{t-1}^i + \alpha^i x_{t-1}^i - q_{2,t-1}^i.$$

There are several case distinctions which depend upon the information conditions. Possibly the simplest is that everyone bids for the consumer good simultaneously, the results of the market are announced then everyone simultaneously decides upon how much money he will "eat." This extensive form is shown in Figure 8.

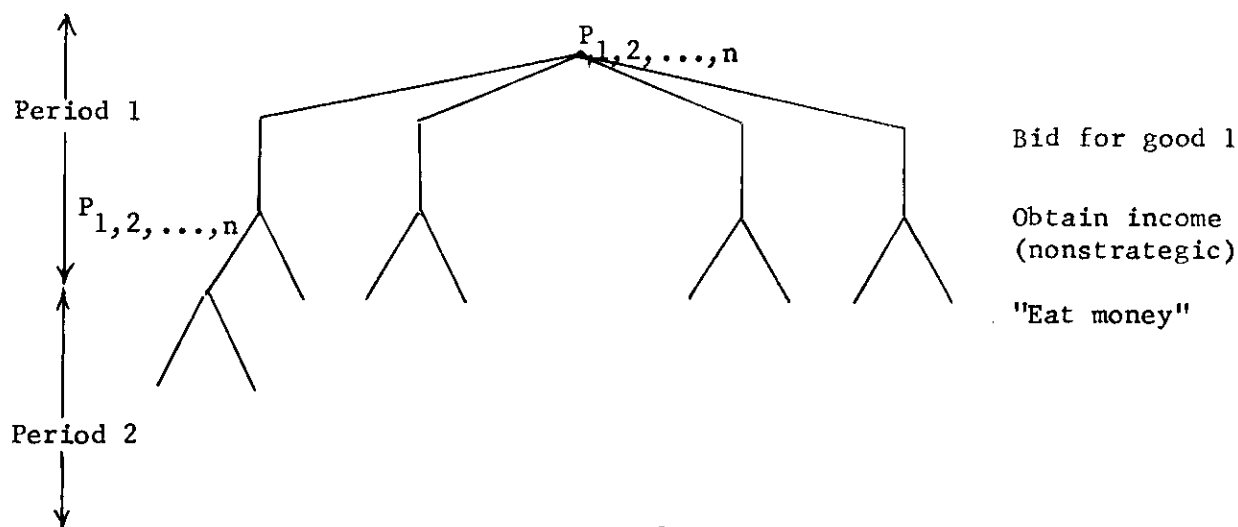

FIGURE 8

We see immediately that a commodity which has no consumption worth (and is not used in production) may serve as a fiat money. It may differ from fiat in its production conditions. We must distinguish commodity monies from fiat according to production and consumption conditions.

10.3. Money and Banking

Only the simplest bank is noted here which is an extension of the model in 9.1 for a multiperiod model.

Model 5. Fiat Money with Credit

The model is almost the same as Model 3 but with credit modifications. The extensive form is as in Figure 6, but for T periods.

Suppose the rate of interest charged or given by the bank for both loans and deposits is ρ . Furthermore individuals borrow or deposit, then spend without added information.

There are many strategic possibilities which cannot be ruled out a priori such as one individual borrowing to deny another funds; or hoarding

even though there is a positive rate paid on deposits. We should expect that an adequate theory will rule out such cases as a result derived from not as an assumption of the theory.

For simplicity however in the model constructed here several assumptions are made which must be rigorously established. They are (a) an individual borrows only to spend and (b) an individual will not hoard if the rate on deposits is positive.

There are n traders, each with an ownership claim of α_i on the consumer good available each period. These amounts are A_1, A_2, \dots, A_T .

Each trader starts with γ_i of fiat money.

The bank will make any loan or accept any deposit. All contracts are short term they are settled at the end of the period in which they are made.

The bank is always in a position to pay its depositors by issuing bank money which may be regarded as a variant of fiat money. The distinction is worth making with care. When individual i borrows the amount $c_{\Delta t}^{i,n+1}$ from a bank one or two pieces of paper may be created. If the bank holds fiat money it may give him the amount $c_{\Delta t}^{i,n+1}$ in fiat money and keep the loan document (which for simplicity at this point we assume to be non-negotiable). The document calls for a repayment of the amount $c_{\Delta t}^{i,n+1}(1+\rho)$. In this instance only one piece of paper has been created.

Suppose instead that the bank as part of the rules of the game has the power to create paper. It issues to a borrower a piece of paper which is a negotiable debt instrument of its own which might be described as $c_{\Delta t}^{n+1,i}$ where by double entry bookkeeping

$$c_{\Delta t}^{n+1,i} \equiv c_{\Delta t}^{i,n+1} .$$

The bank's instrument however is accepted at par with fiat money. In this instance two pieces of two-party paper have been created, one of which adds to the money supply.

If at the end of a period an individual cannot meet his contract with the bank, unlike the bank he does not have the opportunity to roll over his loan. We could enlarge the utility function as has been suggested in 3.3. There is however an alternative which is to specify how the failure to meet contract is to be cured. In this simple example the following (somewhat harsh) rule is employed. He is no longer able to borrow until his loan is paid back.

Let u_t^i be the amount that individual borrows from or deposits in the bank $u_t^i > 0$ means a loan, $u_t^i < 0$ means a deposit.

If C_t^i is the initial financial position of trader i at the start of time t then the amount spent on the consumer good will be:

$$(28) \quad x_t^i = C_t^i + u_t^i$$

where

$$(29) \quad C_t^i = \max[(\alpha^i x_t^i + (1+\rho)u_t^i), 0] .$$

Suppose $c_t^{i,n+1} = \alpha^i x_t^i + (1+\rho)u_t^i < 0$, i.e. at the end of time t individual i fails to meet his obligation by $c_t^{i,n+1}$ then

$$c_{t+1}^{i,n+1} = c_t^{i,n+1}(1+\rho) - \alpha^i x_t .$$

As long as $c_t^{i,n+1} < 0$ then $u_t^i = 0$.

For a game of finite length we must still specify a penalty for ending the game with an unfulfilled contract thus we modify (21) to the form

$$(30) \quad U_i(\tilde{q}_t^i, c_T^{i,n+1}) = \sum_{t=1}^{T-1} \beta_i^{t-1} \varphi_i(q_t^i) + \beta_i^{T-1} \psi_i(q_T^i, c_T^{i,n+1}) .$$

It is conjectured that for $\rho = 0$ there are noncooperative equilibria to this game which are the competitive equilibria in the unconstrained market.

A Simple Example

A simple two trader two-time period model helps to illustrate the market model with fiat money without and with banking.

Consider individual 1 who attempts to maximize

$$(31) \quad \Pi_1 = \frac{x}{x+y} + \beta A \left\{ \frac{1}{2} - x + \frac{x+y}{2} \right\}$$

and individual 2

$$\Pi_2 = \frac{y}{x+y} + \beta A \left\{ \frac{1}{2} - y + \frac{x+y}{2} \right\} .$$

This is a two period economy where each individual starts with an amount of 1/2 of money. Each has the same ownership claim to the manna. This amount is $A_1 = 1$ in period 1 and $A_2 = A$ in period 2. The trade runs

only for two periods. There is a discount factor β . A strategy for Trader 1 is to bid $x \leq 1/2$ in the first period and $\frac{1}{2} - x + \frac{x+y}{2}$ in the second period.

Solving (31) for maximal strategies we obtain

$$(32) \quad \frac{y}{(x+y)^2} = \frac{\beta A}{2}$$

or for a symmetric solution $x = y = 1/2\beta A$. This solution will hold for $\beta A \geq 1$, otherwise we would have $x = y = 1/2$. In particular we may note that for $\beta A < 1$, $x = y < 1/2$ which means that they both hoard during the first period. For example with $\beta = 1$, $A = 2$, $x = y = 1/4$, which means half of all money is hoarded during the first period.

Now we add a bank which is an outside mechanism which functions to accept deposits or make loans up until period $T-1$. In the simple example this means for the first period only.

If we assume that there is a noncooperative solution for which there is no hoarding of money we may then assume that an individual borrows to spend, or deposits excess funds in the bank. Let the bank have one interest rate ρ which it charges for loans or pays on deposits.

Let $u, (v) =$ the amount borrowed or deposited by trader 1, (2). If this is positive it is a loan, negative a deposit. We may immediately write:

$$(33) \quad \Pi_1 = \frac{\frac{1}{2} + u}{1+u+v} + \frac{\beta A \left[\frac{1+u+v}{2} - (1+\rho)u \right]}{1 - \rho(u+v)}$$

and we have a similar expression for Π_2 .

Solving for an optimal policy we obtain:

$$(34) \quad u = v = \frac{1 - \beta A(1+\rho)}{2\{\rho + \beta A(1+\rho)\}} .$$

Using the same example as before suppose $\beta = 1$, $A = 2$ then for $\rho = 0$ $u = v = -1/4$ which means half of all money is deposited during the first period at an interest rate of zero.

Comments

It is relatively easy to set up and obtain a steady state equilibrium solution for T time periods by defining equations analogous to (33) and solving. However, this does not cover the rules needed to prevent unbounded borrowing. A fully specified general model must be more explicit on borrowing rules, and also needs insolvency and bankruptcy conditions to be specified. It is intended to discuss these details in a subsequent paper.

It should be noted that if $\rho \neq 0$ then whenever there is net borrowing or lending in the system the amount of money cannot be conserved without insolvency.

It should be further stressed that the money interest rate ρ is introduced as an exogenous control variable. It must be deduced from the theory that any particular values of ρ have any significant properties such as guaranteeing Pareto optimality of trade.

Because the bank in this model is a mechanism outside of the traders without a direct utility for consumption then the payment of interest to the bank does not imply any distribution of real resources to the bank.

If the system were in a Pareto optimal noncooperative equilibrium*

*and Pareto optimal in the nonmonetary model.

without banking then it remains there regardless of ρ the money rate of interest, otherwise the value of ρ influences the speed of adjustment.

It appears that in a system where all individuals have the same "natural discount" β that somehow the money rate of interest will be linked in an important way to this number. But this is only one of several relevant variables which include depreciation rates, inventory costs, and growth in productivity.

When the dynamic system is weakly interlinked (as is the case in all of the examples given here) then there may easily be more than one money rate of interest which permits the noncooperative game to achieve outcomes which are Pareto optimal in the nonmonetary model. It is conjectured however that in general there will only be one efficient money rate of interest associated with each competitive equilibrium in the nonmonetary system. The qualification "in general" refers to economies where there are many time links such as durable goods. A further qualification is "neutral banking" which means that loans and deposits are instigated by the traders, not the banks. This somewhat loose wording can be made precise by defining the bank as a strategic dummy (like the "house" in Blackjack) who up to the rules of the game it must accommodate borrowers and lenders.

10.4. Productive Assets, Ownership Paper, a Stock Market and Fiat Money

Consider the simple example with two traders and T time periods where $\Pi_1 = \sum_{t=1}^T \beta_1^{t-1} x_t$ and $\Pi_2 = \sum_{t=1}^T \beta_2^{t-1} y_t$ where $1 > \beta_1 > \beta_2$. Suppose that there is a machine which does not depreciate and which produces one unit of output each period. We may consider an issue of ownership paper

such that two traders each hold $1/2$ of the stock. The stock entitles each to a claim of $1/2$ of the income derived from selling the output.

It is easy to see that the competitive equilibrium in this economy, is given by a policy where the trader with the highest discount consumes first until a switchover point is reached at which the other trader then consumes all for the rest of the market. It has been shown by Shubik²³ that without a stockmarket there is no noncooperative equilibrium giving the same distribution of consumption as the competitive equilibrium. If the trader with the highest discount has any income or money after the switchover point there would be no enforcing mechanism within the market to prevent him from spending and thus destroying the equilibrium.

Model 6

In the paper noted above a stockmarket is introduced in which the ownership paper can be sold and with it entitlements to further income. It is shown that in this enlarged market the opportunity for the sale of ownership provides the means for obtaining a noncooperative equilibrium which is Pareto optimal and gives the same distribution as the competitive equilibrium. At the time of switchover of consumption the second trader has completely sold his shares and has neither money nor claims to income left.

As the formal model is presented elsewhere it is not reproduced here, however Figure 9 shows the moves in the game. In this first simple case with a stock market the rule that all shares must be offered for sale every period simplifies both the accounting of periodic income and the mathematical model.

The model in Figure 5a has the random move take place before the traders bid in the market. Thus they know their ownership claims and the total amount of goods that exist before they go into the market to bid.

11.1. Uncertainty without Insurance

Model 7a: No insurance, action with short term uncertainty

A set of simple two period models illustrate the qualitative properties of the closed dynamic models with uncertainty, but no insurance and no banking.

There are three states of the system and ownership claims on the "manna":

With probability 1/3 supply is 1 and ownership (1,0)

With probability 1/3 supply is 1 and ownership (0,1)

With probability 1/3 supply is 2 and ownership (1,1) .

Each trader wishes to maximize his expected income, and begins with 1/2 unit of money,

$$(35) \quad \Pi_1 = \frac{2}{3} \log \left(\frac{x}{x+y} \right) + \frac{1}{3} \log \left(\frac{2x}{x+y} \right) + \beta \left\{ \frac{2}{9} \log \left(\frac{1}{2} - x \right) + \frac{1}{9} \log(1 - 2x) \right. \\ \left. + \frac{2}{9} \log \left(\frac{1}{2} + y \right) + \frac{1}{9} \log(1+2y) + \frac{2}{9} \log \left(\frac{1}{2} + \frac{y-x}{2} \right) + \frac{1}{9} \log(1+y-x) \right\}$$

Solving (35) for a symmetric noncooperative equilibrium we obtain

$$(36) \quad \frac{y}{x(x+y)} = \frac{\beta}{3} \left(\frac{1}{\frac{1}{2} - x} + \frac{1}{\frac{1}{2} + \frac{y-x}{2}} \right)$$

or

$$(37) \quad \frac{1}{2x} = \frac{\beta}{3} \left\{ \frac{1}{\frac{1}{2} - x} + \frac{1}{\frac{1}{2} + \frac{y-x}{2}} \right\} \quad \text{or} \quad x = \frac{3 + 4\beta - \sqrt{16\beta^2 + 9}}{8\beta} .$$

For $\beta = 1$, $x = .25$ and $\Pi_1 = -.4447$.

Model 7b: No insurance, action with short term certainty

In this model nature moves first thus the players will each have to make a decision for each of the 3 states that the system may be in. Player 1 wishes to select numbers x_1 , x_2 , x_3 (the subscripts index the system state) to maximize

$$(38) \quad \Pi_1 = \frac{1}{3} \left[\log \left(\frac{x_1}{x_1 + x_2} \right) + \beta \left(\frac{2}{3} \log \left(\frac{1}{2} - x_1 \right) + \frac{1}{3} \log(1 - 2x_1) \right) \right] \\ + \frac{1}{3} \left[\log \left(\frac{x_2}{x_2 + y_2} \right) + \beta \left(\frac{2}{3} \log \left(\frac{1}{2} - y_2 \right) + \frac{1}{3} \log(1 + 2y_2) \right) \right] \\ + \frac{1}{3} \left[\log \left(\frac{x_3}{x_3 + y_3} \right) + \beta \left(\frac{2}{3} \log \left(\frac{1 + y_3 - x_3}{2} \right) + \frac{1}{3} \log(1 + y_3 - x_3) \right) \right]$$

solving we obtain

$$(39) \quad x_1 = \frac{-(1+\beta) + \sqrt{(1+\beta)^2 + 4\beta}}{4\beta}, \quad x_2 = \frac{1}{2} \quad \text{and} \quad x_3 = \frac{1}{2\beta}.$$

For $\beta = 1$, $x_1 = \frac{-1 + \sqrt{2}}{2} = .207$, $x_2 = .5$ and $x_3 = .5$ similarly $y_1 = .5$, $y_2 = .207$ and $y_3 = .5$. Hence

$$\begin{aligned} \Pi_1 &= \frac{1}{3} [\log(.2930) + \frac{2}{3} \log(.293) + \frac{1}{3} \log(.586)] \\ &\quad + \frac{1}{3} [\log(.707) + \frac{2}{3} \log(.707) + \frac{1}{3} \log(1.414)] \\ &\quad + \frac{1}{3} [\log(.5) + \frac{2}{3} \log(.5)] \\ &= -.6287. \end{aligned}$$

We note here that the extra information lowers the expected equilibrium payoff. This appears to happen because the extra knowledge when the ownership claims are not equal enables the traders to damage each other apparently for immediate advantage.

Model 7c: Competitive Equilibrium with full uncertainty

This is the competitive equilibrium solution to Model a. Here we assume that 12 "contingent commodities" exist. They could be described as "apples in period 1 if states 1, 4 or 7 and apples in period 2 if states 1, 2, ..., 8 or 9. The endowments of Traders 1 and 2 are respectively,

$$\begin{aligned} & (0, 1, 1; 0, 1, 1, 0, 1, 1, 0, 1, 1) \\ & (1, 0, 1; 1, 0, 1, 1, 0, 1, 1, 0, 1) . \end{aligned}$$

Let the commodities be $j = 1, \dots, 12$ then Trader i 's holdings of commodity j is x_j^i . Thus

$$(40) \quad \pi_i = \frac{1}{3} \sum_{j=1}^3 \log x_j^i + \frac{1}{9} \sum_{j=4}^{12} \log x_j^i .$$

By symmetry $\pi_1 = \pi_2 = -.40137$, and the prices are:

$$(2, 2, 1; 2, 2, 1, 2, 2, 1, 2, 2, 1) .$$

11.2. Uncertainty with Insurance

We introduce an insurance agency which is an exogenous mechanism. In order to completely define its role we must specify whether it has a fund of fiat money at its disposal or if it is in a position to create money, or exactly how it underwrites its policies. The nature of the

contract must be specified in complete detail concerning whether it is money for future money or whether it relates to other types of payments.

The simplest model is that of an exogenous insurance company which we may regard as being backed by the state who has unlimited possibilities for creating the fiat money needed to pay any claims on the company.

We assume that at any period t the company has the following information:

- (i) it knows the amount of fiat money in the hands of each trader;
- (ii) it knows the expected amount of the consumer good available next trading period and the expected ownership claims of each trader.

Let E_i be the expected ownership claim of trader i at any time t ; and E be the expected overall amount of good for sale.

Let c_t^i be the amount of fiat money held by trader i at the start of time t . We consider a game where, before the random move the traders may buy insurance (in this simple model, the insurance agency is not a player and we limit our consideration to having players buy or not buy insurance, we need also to consider a more general model in which they can also sell insurance).

The insurance company sells a contract at a risk premium η ($\eta = 0$ is a fair bet) such that it will pay individual i the amount:

$$\frac{E_i}{E}(x_t + y_t) \left(\frac{1}{1+\eta} \right)$$

at the end of time t in return for his actual income from the market during time t . In this simple example the insurance company may be regarded as a factoring agency which offers a certain income against uncertain receivables.

The extensive form (for case a) is as shown in Figure 10.

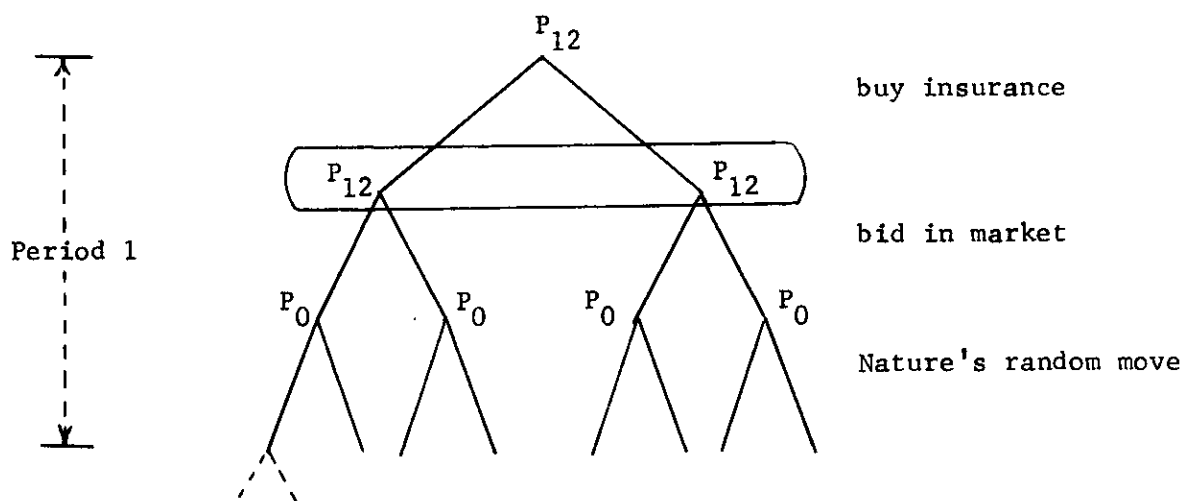

FIGURE 10

We assume that the insurance policies can be purchased in any denomination thus in the two trader market the traders have a strategic variable w_t and z_t where $0 \leq w_t \leq 1$, $0 \leq z_t \leq 1$. The 0 values imply no insurance and the values of 1 imply an insurance of all income.

Model 8a. Insurance and short term uncertainty

The payoff for Trader 1 is as follows

$$(41) \quad \Pi_1 = \frac{2}{3} \log \left(\frac{x}{x+y} \right) + \frac{1}{3} \log \left(\frac{2x}{x+y} \right) + \beta \left\{ \frac{2}{9} \log(x_1) + \frac{1}{9} \log(2x_1) \right. \\ \left. + \frac{2}{9} \log(x_2) + \frac{1}{9} \log(2x_2) + \frac{2}{9} \log(x_3) + \frac{1}{9} \log(2x_3) \right\}$$

$$\begin{aligned} \text{where } x_1 &= w \left(\frac{x+y}{2} \right) \left(\frac{1}{1+\eta} \right) + (1-w) \left(\frac{1}{2} - x \right) \\ x_2 &= w \left(\frac{x+y}{2} \right) \left(\frac{1}{1+\eta} \right) + (1-w) \left(\frac{1}{2} + y \right) \\ x_3 &= w \left(\frac{x+y}{2} \right) \left(\frac{1}{1+\eta} \right) + (1-w) \left(\frac{1}{2} + \frac{y-x}{2} \right) \end{aligned}$$

and a similar expression exists for Trader 2.

The solution for a perfect equilibrium calls for Trader 1 to maximize over x and w and Trader 2 to maximize over y and z .

Let us make a guess that there are values of η such that in equilibrium both traders completely insure. If this were so we could rewrite (41) as:

$$(42) \quad \Pi_1 = \log \left(\frac{x}{x+y} \right) + \frac{1}{3} \log 2 + \beta \log \left(\frac{\frac{1}{2} - x + \left(\frac{x+y}{2} \right) \left(\frac{1}{1+\eta} \right)}{1 - (x+y) \left(\frac{\eta}{1+\eta} \right)} \right) + \frac{\beta}{3} \log 2 .$$

Solving for the symmetric solution we obtain

$$(43) \quad x = \frac{1+\eta}{2\{\beta(1+\eta) + \eta\}} .$$

For $\eta = 0$, $x = 1/2\beta$, and $\beta = 1/1+\eta$, $x = 1/2$. However substituting (43) into (42) we obtain immediately

$$(44) \quad \Pi_1 = \log \frac{1}{2} + \beta \log \frac{1}{2} + \frac{1}{3}(1+\beta) \log 2$$

for $\beta = 1$, $\Pi_1 = -.40137$. But this is precisely the same as the competitive equilibrium solution.

12. Conclusions: Mathematical Institutional Economics

12.1. Some Modeling Details

The approach adopted here stresses explicit detailed modeling to the point that if you cannot play the game described in a classroom or laboratory then it is not well defined. By adopting this approach several key obstacles to understanding monetary phenomena are overcome. In particular:

- (1) Pecuniary externalities are real
- (2) Tatonnement processes are avoided
- (3) The velocity of money is not a particularly important variable.

(1) Markets strategically connect trading groups. The specific nature of how this leads to pecuniary externalities has been discussed elsewhere.²⁴

(2) There may well be myriads of different trading and production arrangements which lead to price formation. The tatonnement process was an unsatisfactory way of avoiding any of them. The approach here is only a start. It specifies one way of price formation. The next step calls for a sensitivity analysis over alternative procedures and some empirical guidance to choose among them.

(3) The model presented here has as a first approximation, a fixed time period. The velocity of money can only vary if individuals hoard it or save it. It is relatively easy to model time lags in payments/which are either strategic or nonstrategic which would immediately create a "float" and introduce the timing of payments as a factor influencing velocity.

But this appears to have little more significance than does the hoarding of inventories or lags in physical good distribution. In a hyperinflation the speed at which an individual can run to the bank may be of some interest, but almost always other financial factors appear to be of more importance than velocity regarded as a strategic variable.

12.2. Rules, Institutions and Laws

The financial system including money, other financial instruments and institutions must be viewed holistically. Money is not defined without giving all of the rules for its operation in a financial process.

In our attempt to define process we are forced to define rules which amount to inventing institutions and laws. As most of these rules are for the guidance of the system in a disequilibrium state it is not surprising that most of them apparently disappear at a stationary equilibrium.

12.3. The Key Solution Concept Restated

Any solution concept to be adequate for the development of a theory of money and financial institutions must be defined for

(1) Nonsymmetric information conditions

and (2) few as well as many traders.

Furthermore the models to which the solution concept is applied must be defined for all states of the system--not merely for the equilibrium states and local neighborhoods around them.

The noncooperative equilibrium has these properties and gives the competitive equilibrium results as a special case.

The noncooperative equilibrium however can be regarded as a special case of a broader scheme of behavioral mechanisms.

12.4. The Central Role of Information and Communication

Information clearly plays a central role. The institutions forming the financial infrastructure of a society may be viewed as information processing and communicating control devices. The approach adopted here is not yet sufficiently advanced to be able to handle many of the subtle features of communication but at least for a noncooperative game with an economic structure a way to evaluate the worth of information with respect to a solution concept is by having a solution concept defined for all information states and performing a sensitivity analysis with respect to changes in information. An example of this approach where more information had negative worth was given in the insurance models in Section 11.1.

12.5. On Mathematical Institutional Economics

The right mathematical model of economic process will call for the invention of the rudimentary institutions (such as banks, insurance companies and markets) to carry and control the processes. The differences among institutions the world over may depend upon detailed variables and special conditions not touched upon in the mathematical simplification. Nevertheless a mathematical institutional economics must be able to portray the essential features of institutions which exist or need to exist without an immediate need to proceed to great detail.

A mathematical institutional economics must be in harmony with an institutional economics in the sense that it should be relatively easy to reconcile the role of any actual institution with the theory. The added detail and special variables should be easy to spot and if need be incorporate in the theoretical framework.

A mathematical institutional economics should be in harmony with mathematical economics. A key test here is whether or not it gives the same results to well understood problems and gives more results elsewhere.

REFERENCES

1. Shubik, M. "An Informal Guide to Some Papers on a Theory of Money and Financial Institutions," Cowles Foundation CF-40531, May 29, 1974.
2. Shubik, M. "On the Eight Basic Units of a Dynamic Economy with Spot and Futures Markets," CFDP 367, 1974. (To appear in The Review of Income and Wealth.)
3. Levitan, R. E. and M. Shubik. "Duopoly with Price and Quantity as Strategic Variables."
4. Chamberlin, E. H. The Theory of Monopolistic Competition. Cambridge: Harvard University Press, 6th ed., 1950 (originally published 1933).
5. Shubik, M. "Commodity Money, Oligopoly Credit and Bankruptcy in a General Equilibrium Model," Western Economic Journal, Vol. X, No. 4 (1972), 24-38.
6. Shapley, L. S. and M. Shubik. "Trade Using One Commodity as a Money," Cowles Foundation CF-40318, April 3, 1974.
7. Shubik, M. "A Trading Model to Avoid Tatonnement Metaphysics," CFDP 368, 1974.
8. Vickrey, W. "Counterspeculation, Auctions and Competitive Sealed Tenders," Journal of Finance, Vol. 16 (1961), 8-37.
9. Harsanyi, J. "Games with Incomplete Information Played by Bayesian Players, Part II," Management Science, Vol. 14, No. 5 (1968), 320-334. (See also Parts I, III.)
10. Shubik, M. "Information, Duopoly and Competitive Markets: A Sensitivity Analysis," Kyklos, Vol. 26, No. 4 (1973), 736-761.
11. Gillies, D. "Solutions to General Nonzero Sum Games," Ann. Math. Study, Vol. 40, 47-85.
12. Shapley, L. S. "A Value for n Person Games," in Contributions to the Theory of Games II, 1953 Ann. Math. Studies 28, Princeton, Princeton University Press, 307-317.
13. Shapley, L. S. and M. Shubik. "Competition Welfare and the Theory of Games" (in process), Chapter 6, 1973, RAND R-904-NSF/6.
14. Arrow, K. J. and G. Debreu. "Existence of an Equilibrium for a Competitive Economy," Econometrica, Vol. 22 (1954), 265-290.

15. Shubik, M. "Competitive and Controlled Price Economies; The Arrow-Debreu Model Revisited," CFDP 337, 1972.
16. Cournot, A. A. Researches into the Mathematical Principles of Wealth, 1897, New York: Macmillan (original in French, 1838).
17. Nash, J. F., Jr. "Equilibrium Points in N-Person Games," Proc. Nat. Acad. Sci. U.S.A., Vol. 38 (1952), 886-893.
18. Selten, R. "Bewertung strategischer Spiele," Zeitschrift fur die gesamte Staatswissenschaft, 116 (1960), 221-282.
19. Shubik, M. "Money, Trust and Equilibrium Points for Games in Extensive Form," to appear in Zeitschrift fur Nationaloekonomie, 1974.
20. Shapley, L. S. and M. Shubik. op.cit., Ch. 2, R-904-NSF/2
21. Shapley, L. S. "Noncooperative General Exchange," mimeographed, July 1974.
22. Shubik, M. and W. Whitt. "Fiat Money with One Nondurable Good and No Credit" in Topics in Differential Games, A. Blaquiere (ed.). Amsterdam: North Holland, 1973.
23. Shubik, M. "A Dynamic Economy with Fiat Money without Banking and with and without Production Goods," CFDP 364, 1973.
24. Shubik, M. "Pecuniary Externalities: A Game Theoretic Analysis," American Economic Review, Vol. 59, No. 4 (1971), 713-718.