

# Randomized Controlled Trial of Interval-Compressed Chemotherapy for the Treatment of Localized Ewing Sarcoma: A Report From the Children's Oncology Group

Richard B. Womer, Daniel C. West, Mark D. Krailo, Paul S. Dickman, Bruce R. Pawel, Holcombe E. Grier, Karen Marcus, Scott Sailer, John H. Healey, John P. Dormans, and Aaron R. Weiss

## ABSTRACT

### Purpose

Chemotherapy with alternating vincristine-doxorubicin-cyclophosphamide and ifosfamide-etoposide cycles and primary tumor treatment with surgery and/or radiation therapy constitute the usual approach to localized Ewing sarcoma in North America. We tested whether chemotherapy intensification through interval compression could improve outcome.

### Patients and Methods

This was a prospective, randomized controlled trial for patients younger than 50 years old with newly diagnosed localized extradural Ewing sarcoma. Patients assigned to standard and intensified treatment were to begin chemotherapy cycles every 21 and 14 days, respectively, provided an absolute neutrophil count greater than  $750 \times 10^6/L$  and a platelet count greater than  $75 \times 10^9/L$ . Patients received vincristine ( $2 \text{ mg}/\text{m}^2$ ), doxorubicin ( $75 \text{ mg}/\text{m}^2$ ), and cyclophosphamide ( $1.2 \text{ g}/\text{m}^2$ ) alternating with ifosfamide ( $9 \text{ g}/\text{m}^2$ ) and etoposide ( $500 \text{ mg}/\text{m}^2$ ) for 14 cycles, with filgrastim ( $5 \text{ mg}/\text{kg}$  per day; maximum, 300 mg) between cycles. Primary tumor treatment (surgery, radiation, or both) was to begin at week 13 (after four cycles in the standard arm and six cycles in the intensified arm). The primary end point was event-free survival (EFS). The study is registered at ClinicalTrials.gov (identifier: NCT00006734).

### Results

Five hundred eighty-seven patients were enrolled and randomly assigned, and 568 patients were eligible, with 284 patients in each regimen. For all cycles, the median cycle interval for standard treatment was 21 days (mean, 22.45 days); for intensified treatment, the median interval was 15 days (mean, 17.29 days). EFS at a median of 5 years was 65% in the standard arm and 73% in the intensified arm ( $P = .048$ ). The toxicity of the regimens was similar.

### Conclusion

For localized Ewing sarcoma, chemotherapy administered every 2 weeks is more effective than chemotherapy administered every 3 weeks, with no increase in toxicity.

*J Clin Oncol* 30:4148-4154. © 2012 by American Society of Clinical Oncology

## INTRODUCTION

Since the first Intergroup Ewing's Sarcoma Study (IESS) in the 1970s, it has been clear that chemotherapy, with primary tumor treatment involving surgery or radiotherapy, is indispensable for successful treatment of Ewing sarcoma and related tumors.<sup>1</sup> IEES-I established the importance of doxorubicin in Ewing sarcoma chemotherapy, whereas IEES-II and subsequent meta-analyses showed the importance of doxorubicin dose-intensity.<sup>2-4</sup> The North American intergroup Ewing sarcoma study INT-0091 demonstrated that a regimen of alternating vincristine-doxorubicin-cyclophosphamide (VDC) and ifosfamide-etoposide (IE) was superior to VDC,

with approximately 70% of patients with localized tumors apparently cured.<sup>5</sup>

In the absence of new effective agents for Ewing sarcoma, the Children's Oncology Group focused on improving outcome by increasing chemotherapy dose-intensity. There are two ways to increase the dose-intensity of chemotherapy, increasing the doses given or decreasing the interval between doses. The Pediatric Oncology Group and Children's Cancer Group explored the first method in the INT-0154 study, whose standard arm used VDC/IE in standard doses for 17 cycles administered every 3 weeks, whereas the experimental arm used 11 higher dose cycles administered every 3 weeks to complete treatment with the same total doses. The results

Richard B. Womer, Bruce R. Pawel, and John P. Dormans, Children's Hospital of Philadelphia and University of Pennsylvania, Philadelphia, PA; Daniel C. West, University of California, San Francisco, San Francisco; Mark D. Krailo, Children's Oncology Group, Arcadia, CA; Paul S. Dickman, Phoenix Children's Hospital, Phoenix, AZ; Holcombe E. Grier, Karen Marcus, Dana-Farber Cancer Institute, Boston, MA; Scott Sailer, University of North Carolina, Chapel Hill, NC; John H. Healey, Memorial Sloan-Kettering Cancer Center, New York, NY; Aaron R. Weiss, University of Medicine and Dentistry of New Jersey—Robert Wood Johnson University Hospital, New Brunswick, NJ.

Submitted January 6, 2012; accepted July 24, 2012; published online ahead of print at www.jco.org on October 22, 2012.

Supported by National Cancer Institute Grants No. U10-CA98543 and U10-CA98413 to the Children's Oncology Group and by the Daniel P. Sullivan Fund (R.B.W. and J.H.H.). Partial support for statistical analyses came from the Nick Curry Foundation at CureSearch for Children's Cancer.

Presented in part at the 13th Annual Meeting of the Connective Tissue Oncology Society, October 31-November 3, 2007, Seattle, WA; and at the 44th Annual Meeting of the American Society of Clinical Oncology, May 30-June 3, 2008, Chicago, IL.

Authors' disclosures of potential conflicts of interest and author contributions are found at the end of this article.

Clinical trial information: NCT00006734.

Corresponding author: Richard B. Womer, MD, Division of Oncology, CTRB 10, The Children's Hospital of Philadelphia, 3501 Civic Center Blvd, Philadelphia, PA 19104; e-mail: rwomer@upenn.edu.

© 2012 by American Society of Clinical Oncology

0732-183X/12/3033-4148/\$20.00

DOI: 10.1200/JCO.2011.41.5703

showed no improvement in event-free survival (EFS) or overall survival but higher toxicity in the dose-intense arm.<sup>6</sup>

A pilot study demonstrated the feasibility of dose intensification by interval compression (sometimes termed increased dose density) using filgrastim between chemotherapy cycles. Induction cycles had a median duration of 16 days, and although cycle duration increased with continuing therapy, the median duration was still 21 days or less at cycle 11. Toxicity was well within the range usually associated with Ewing sarcoma therapy.<sup>7</sup> This study was designed to test whether dose intensification by interval compression could improve the prognosis of patients with localized Ewing sarcoma.

## PATIENTS AND METHODS

Protocol AEWS0031 was available to member institutions of the Children's Oncology Group from May 2001 to August 2005. The study was also open to members of the Southwest Oncology Group from July 2003 to August 2005, but no eligible patients were enrolled.

### Patient Eligibility

To be eligible, patients had to have a new diagnosis of Ewing sarcoma, peripheral neuroectodermal tumor, primitive neuroectodermal tumor, or Askin's tumor. The primary site could be bone or soft tissue, but not intradural soft tissues. Patients could have no evidence of metastatic disease on a radionuclide bone scan, chest computed tomography scan, and bilateral bone marrow aspirates and biopsies. We considered one pulmonary or pleural nodule greater than 1 cm in diameter or more than one nodule greater than 0.5 cm in diameter on chest computed tomography scan to be evidence of metastasis. Patients with chest wall tumors and ipsilateral pleural effusions or pleural-based secondary nodules were considered to have localized disease, as were patients with clinically or pathologically involved regional lymph nodes. We excluded patients with a history of any other malignancy (except skin cancer not treated with chemotherapy, radiation, or immunotherapy); pregnant or lactating patients; and patients with inadequate heart, renal, or liver function. Chemotherapy had to begin within 30 days of initial biopsy. All patients (> age 18 years) or their parents or guardians signed written informed consent for participation. The Children's Oncology Group does not ascertain potential patients except through study enrollment, and the computerized remote enrollment system rejected patients whose entered data did not meet these requirements.

Pathologically, the tumor had to have a light microscopic appearance (using hematoxylin and eosin) consistent with a Ewing family tumor with no immunohistochemical or ultrastructural evidence indicating otherwise. Immunohistochemical use of a panel of muscle-specific antibodies and antibodies to lymphoid antigens was recommended; CD99 positivity and evidence of an appropriate *EWS* rearrangement by reverse transcriptase polymerase chain reaction or fluorescent in situ hybridization were considered supportive. At least one study pathologist (P.S.D. or B.R.P.) reviewed all diagnostic slides and test results.

### Study Design

Patients were randomly assigned to the control regimen A or the experimental regimen B (Fig 1). Patients assigned to regimen A received chemotherapy every 21 days, whereas patients assigned to regimen B received chemotherapy every 14 days or as soon as blood count recovery permitted. Both regimens used 14 alternating cycles of VDC/IE with filgrastim, with identical per-cycle and total doses. Treatment also included primary tumor treatment with surgery, radiation, or a combination. Detailed treatment schedules for patients receiving various primary tumor treatment modalities are listed in Appendix Table A1 (online only).

Filgrastim administration was to stop when the absolute neutrophil count (ANC) was at least  $750 \times 10^6/L$  and the platelet count at least  $75 \times 10^9/L$ . Once ANC and platelet count criteria were met, chemotherapy was to proceed 24 hours after the last filgrastim dose regardless of whether the ANC decreased after discontinuation of filgrastim. With the chemotherapy cycle beginning on

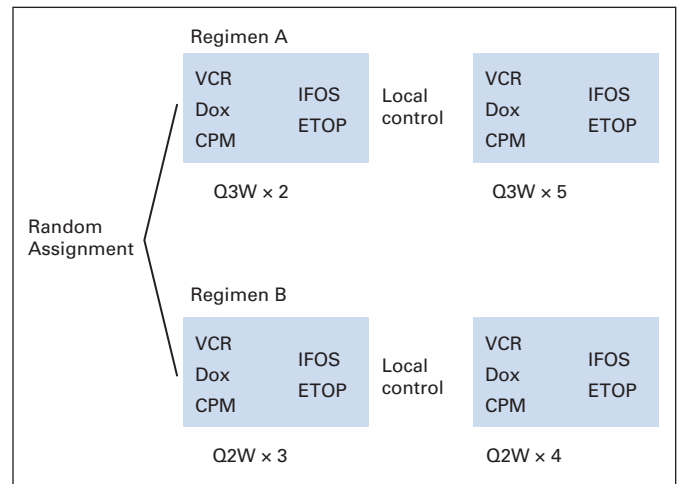

**Fig 1.** Design of the study. Regimen A was the control regimen, and regimen B was the experimental (intensified) regimen. Cycles of vincristine-doxorubicin-cyclophosphamide alternated with cycles of ifosfamide-etoposide. CPM, cyclophosphamide (1,200 mg/m<sup>2</sup> on day 1 of each cycle); Dox, doxorubicin (37.5 mg/m<sup>2</sup> on days 1 and 2 of each cycle; cumulative dose, 375 mg/m<sup>2</sup> for all patients); ETOP, etoposide (100 mg/m<sup>2</sup> on days 1 through 5 of each cycle); IFOS, ifosfamide (1,800 mg/m<sup>2</sup> on days 1 through 5 of each cycle); VCR, vincristine (1.5 mg/m<sup>2</sup> [maximum, 2 mg] on day 1 of each cycle); Q2W, every 2 weeks; Q3W, every 3 weeks.

day 0, patients on regimen A were to have blood counts checked on days 7, 14, and 21; patients on regimen B were to have counts checked on days 7 and 14 and then every Monday, Wednesday, and Friday until blood count criteria were met.

Primary tumor treatment began at treatment week 13, after four cycles of chemotherapy in regimen A and six cycles in regimen B. It could consist of complete surgical excision with clear margins, surgery with radiation therapy for close or positive margins, or radiation therapy alone. Minimal adequate bony margins to avoid radiation therapy were defined as 1 cm (2 to 5 cm recommended), and minimal soft tissue margins were defined as 5 mm in muscle or fat or 2 mm with fascial planes. Radiation therapy doses were 45 Gy to the initial volume and 55.8 Gy to the final volume of unresected tumors, 50.4 Gy to extraosseous tumors with a complete response to chemotherapy, 45 Gy to vertebral bony primary tumors, and 45 Gy to pathologically involved lymph node areas. Preoperative radiotherapy was permitted with a dose of 45 Gy. Patients with chest wall primary tumors and ipsilateral pleural-based tumor nodules received 15 Gy to the hemithorax (12 Gy for patients < 6 years old) and 36.6 Gy to any unresected gross pleural tumor. All radiation therapy was to be given in 1.8-Gy fractions.

### Statistical Design

Institutional investigators enrolled patients using a Web-based interface. At enrollment, patients were stratified into groups according to age ( $\leq 17$  years  $v \geq 18$  years) and primary tumor site (nonpelvic  $v$  pelvic). After eligibility was confirmed, the randomized treatment assignment was generated by computer and reported to the investigator. Assignments were done in permuted blocks of size four.<sup>8</sup>

Enrollment of 4.5 years with an additional year of follow-up provided for the detection of a hazard ratio (HR) of 0.64 in the failure rate with a probability of 0.80 when using a two-sided test with size  $P = .05$ . Four instances of interim monitoring were planned. The final analysis was planned for 5.5 years after the first patient was enrolled. Data current through March 2009 (7.8 years after first enrollment) were used in this analysis.

The primary study end point was EFS, defined as the time from entry onto the study until the occurrence of an adverse event (disease progression, second malignant neoplasm, or death) or until the last contact with the patient, whichever came first. Disease progression was further subclassified as local progression (at the primary site only), systemic progression (at a site other than the primary site), or local plus systemic progression (at the primary site and another site).

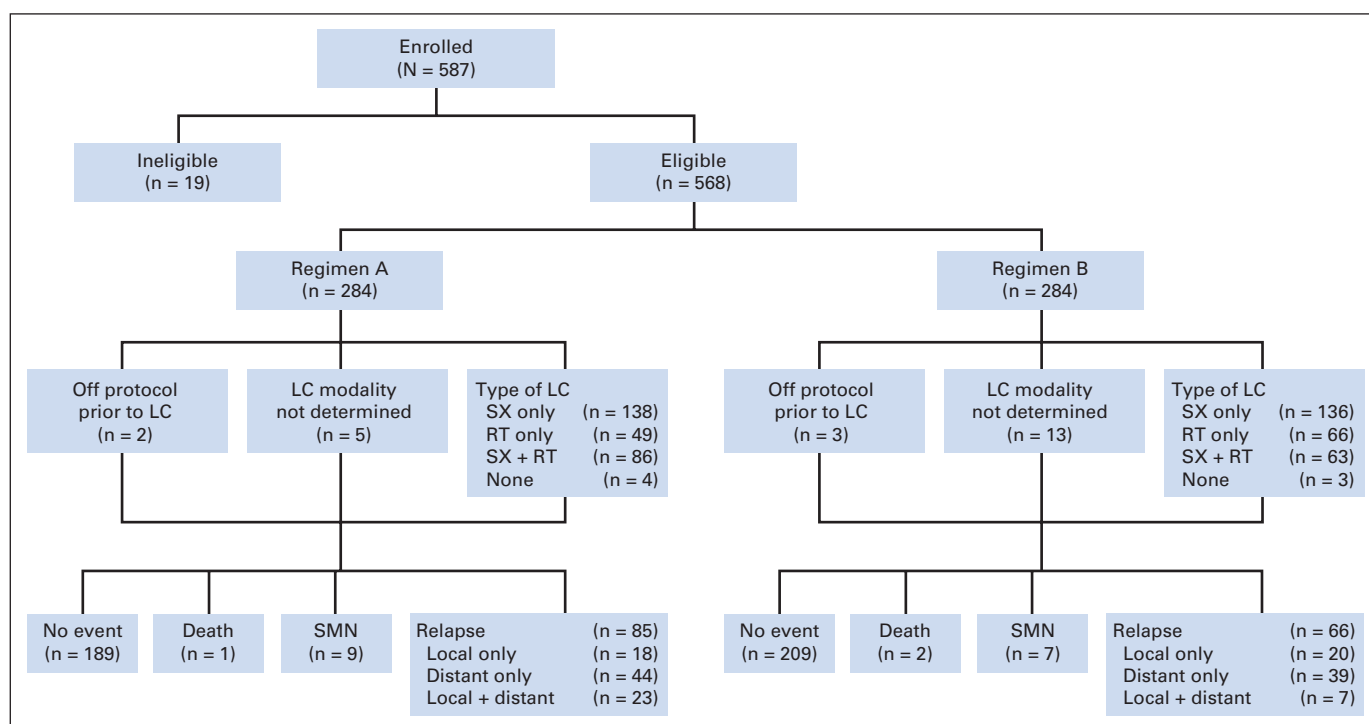

**Fig 2.** CONSORT diagram. Patients who experienced a relapse, second malignant neoplasm (SMN), or death before the last contact date were counted as having an event. LC, local control; RT, radiation therapy; SX, surgery.

EFS was estimated by the Kaplan-Meier method.<sup>9</sup> The log-rank statistic was used to compare the risk of an adverse event between patient groups.<sup>10</sup> Patients' randomized treatment assignments were used in all comparisons involving regimens. The HRs and significance associated with patient characteristics at enrollment were assessed in a proportional hazards regression model in which the characteristic of interest was the only component.<sup>10</sup> CIs for HRs were derived from that model. The cumulative incidence of each type of event was calculated according to Prentice et al.<sup>11</sup> Cumulative incidence was compared across regimens using the method of Fine and Gray.<sup>12</sup> The hypothesis of equal frequency of qualitative characteristics across groups defined by treatment assignment was assessed using the exact conditional test of proportions.<sup>13</sup>

The number of days required to complete a cycle of therapy and the number of days hospitalized during each cycle were compared across randomly assigned regimens using the Wilcoxon signed rank test. The relative average intensity of the regimens was estimated as the mean days for standard timing cycles divided by that for intensified cycles. STATA version 12 (STATA, College Station, TX) was used for all analyses of censored survival data and cumulative incidence; SAS version 9.2 (SAS Institute, Cary, NC) was used for all other statistical calculations.

## RESULTS

### Patient Accrual and Random Assignment

Five hundred eighty-seven patients were enrolled onto the study (Fig 2) from 152 institutions. Nineteen patients were deemed ineligible, 12 because of a wrong diagnosis (not Ewing sarcoma), four because of metastases at diagnosis, two because of treatment before enrollment or random assignment, and one because treatment began more than 30 days after biopsy. Thus, 568 patients were eligible, with 284 patients assigned to each regimen (Table 1). At the time of analysis, 398 patients had not experienced an EFS event (median follow-up, 61 months; range, 7 to 94 months).

### Chemotherapy Intensification

We analyzed 2,897 cycles in regimen A and 2,862 cycles in regimen B. For all patients and all phases, the mean cycle durations were  $22.45 \pm 4.87$  days and  $17.29 \pm 5.40$  days in regimens A and B, respectively ( $P < .001$ ; Table 2). Patients age 17 years and younger had almost identical cycle durations as older patients.

Because we observed in the pilot study that radiation therapy led to prolongation of continuation chemotherapy cycles,<sup>7</sup> we analyzed them separately for patients treated with and without radiation therapy. Patients on regimen B treated with radiation had mean and median continuation cycle durations that were approximately 1.5 days longer than patients who were not treated with radiation, but the durations were still significantly shorter than in regimen A. Even patients with irradiated pelvic tumors had shorter cycle durations than their nonirradiated counterparts.

### Local Control Measures

We were unable to determine the method of primary tumor treatment in 18 patients, five patients had events before local control, and seven patients had no local control measures reported. Of the remaining patients, 274 had surgery only, 115 had radiation only, and 149 had both. The local control measures differed between the two regimens, with more patients treated on the standard arm receiving surgery and radiation and more patients on the intensive regimen receiving radiation alone (Fig 2), but the differences did not achieve statistical significance ( $P = .101$  by Fisher's exact test).

### Treatment Efficacy

At 5 years, the EFS rate on regimen B was 73%, compared with 65% on regimen A ( $P = .048$ ; Fig 3A); the HR associated with regimen B was 0.74 (95% CI, 0.54 to 0.99). Overall survival was 83% for

**Interval-Compressed Chemotherapy for Localized Ewing Sarcoma**

**Table 1.** Patient Demographics and Clinical Characteristics

| Demographic or Clinical Characteristic         | Standard Timing: Regimen A |       | Intensive Timing: Regimen B |    | All Patients    |       |
|--|----------------------------|-------|-----------------------------|----|-----------------|-------|
|  | No. of Patients            | %     | No. of Patients             | %  | No. of Patients | %     |
| Age at diagnosis, years                        |                            |       |                             |    |                 |       |
| ≤ 9  | 88                         | 31    | 74                          | 26 | 162             | 29    |
| 10-17  | 165                        | 58    | 174                         | 61 | 339             | 60    |
| 18+  | 31                         | 11    | 36                          | 13 | 67              | 12    |
| Median   | 12                         |       | 13                          |    | 12              |       |
| Range  | 0-33                       |       | 0-45                        |    | 0-45            |       |
| Sex  |                            |       |                             |    |                 |       |
| Male   | 154                        | 54    | 154                         | 54 | 308             | 54    |
| Female   | 130                        | 46    | 130                         | 46 | 260             | 46    |
| Race   |                            |       |                             |    |                 |       |
| White  | 252                        | 89    | 250                         | 88 | 502             | 88    |
| African American                               | 8                          | 3     | 6                           | 2  | 14              | 2     |
| American Indian                                | 3                          | 1     | 2                           | 1  | 5               | 1     |
| Asian  | 8                          | 3     | 8                           | 3  | 16              | 3     |
| Pacific Islander                               | 1                          | 0.003 | 0                           | 0  | 1               | 0.001 |
| Not reported                                   | 12                         | 4     | 18                          | 6  | 30              | 5     |
| Ethnicity                                      |                            |       |                             |    |                 |       |
| Not Hispanic                                   | 258                        | 91    | 250                         | 88 | 508             | 89    |
| Hispanic                                       | 21                         | 7     | 29                          | 10 | 50              | 9     |
| Not reported                                   | 5                          | 2     | 5                           | 2  | 10              | 3     |
| Primary site (bone unless otherwise specified) |                            |       |                             |    |                 |       |
| Skull  | 18                         | 6     | 13                          | 5  | 31              | 5     |
| Spine  | 14                         | 5     | 30                          | 11 | 44              | 8     |
| Ribs   | 34                         | 12    | 25                          | 9  | 59              | 10    |
| Sternum, scapula, or clavicle                  | 15                         | 5     | 15                          | 5  | 30              | 5     |
| Humerus  | 13                         | 5     | 12                          | 4  | 25              | 4     |
| Radius, ulna, or bone of the hand              | 7                          | 2     | 8                           | 3  | 15              | 3     |
| Pelvis   | 47                         | 17    | 43                          | 15 | 90              | 16    |
| Femur  | 33                         | 12    | 28                          | 10 | 61              | 11    |
| Tibia, fibula, patella, or bone of the foot    | 51                         | 18    | 43                          | 15 | 94              | 17    |
| Soft tissue                                    | 52                         | 18    | 67                          | 24 | 119             | 21    |

regimen B and 77% for regimen A ( $P = .056$ ; Fig 3B); the HR associated with regimen B was 0.69 (95% CI, 0.47 to 1.0).

Interval-compressed therapy had no apparent effect on local recurrence (5-year cumulative incidence: 0.080 for regimen A; 95% CI, 0.052 to 0.12; 0.072 for regimen B; 95% CI, 0.045 to 0.11;  $P = .74$ ) but was related to distant and combined local and distant relapse

(5-year cumulative incidence: 0.23 for regimen A; 95% CI, 0.19 to 0.30; 0.16 for regimen B; 95% CI, 0.13 to 0.23;  $P = .058$ ; Fig 2).<sup>11</sup>

Combining the treatment arms, older patients and patients with pelvic primary tumors were at relative disadvantages ( $P < .001$  for EFS and survival; Figs 3C and 3D). In particular, outcome was considerably worse for patients age 18 years and older

**Table 2.** Dose Intensification

| Group                   | Cycle Duration in Regimen A:<br>Standard Timing (days) |      |        | Cycle Duration in Regimen B:<br>Intensified Timing (days) |      |        | <i>P</i> |
|-------------------------|--|------|--------|---|------|--------|----------|
|                         | Mean   | SD   | Median | Mean  | SD   | Median |          |
| All                     | 22.45  | 4.87 | 21     | 17.29   | 5.40 | 15     | < .001   |
| Induction               | 21.65  | 2.64 | 21     | 16.23   | 4.46 | 15     | < .001   |
| Continuation            | 22.84  | 5.62 | 21     | 18.17   | 5.74 | 16     | < .001   |
| Continuation with RT    | 23.00  | 5.18 | 21     | 19.2  | 6.12 | 18     | < .001   |
| Continuation without RT | 22.73  | 5.79 | 21     | 17.71   | 5.45 | 16     | < .001   |
| Pelvic with RT          | 24.18  | 6.79 | 21     | 19.61   | 5.76 | 19     | < .001   |
| Pelvic without RT       | 22.39  | 5.37 | 21     | 17.36   | 5.93 | 15     | < .001   |
| All age 0-17 years      | 22.48  | 4.93 | 21     | 17.31   | 5.30 | 15     | < .001   |
| All age ≥ 18 years      | 22.21  | 4.53 | 21     | 17.16   | 6.20 | 15     | < .001   |

Abbreviations: RT, radiation therapy; SD, standard deviation.

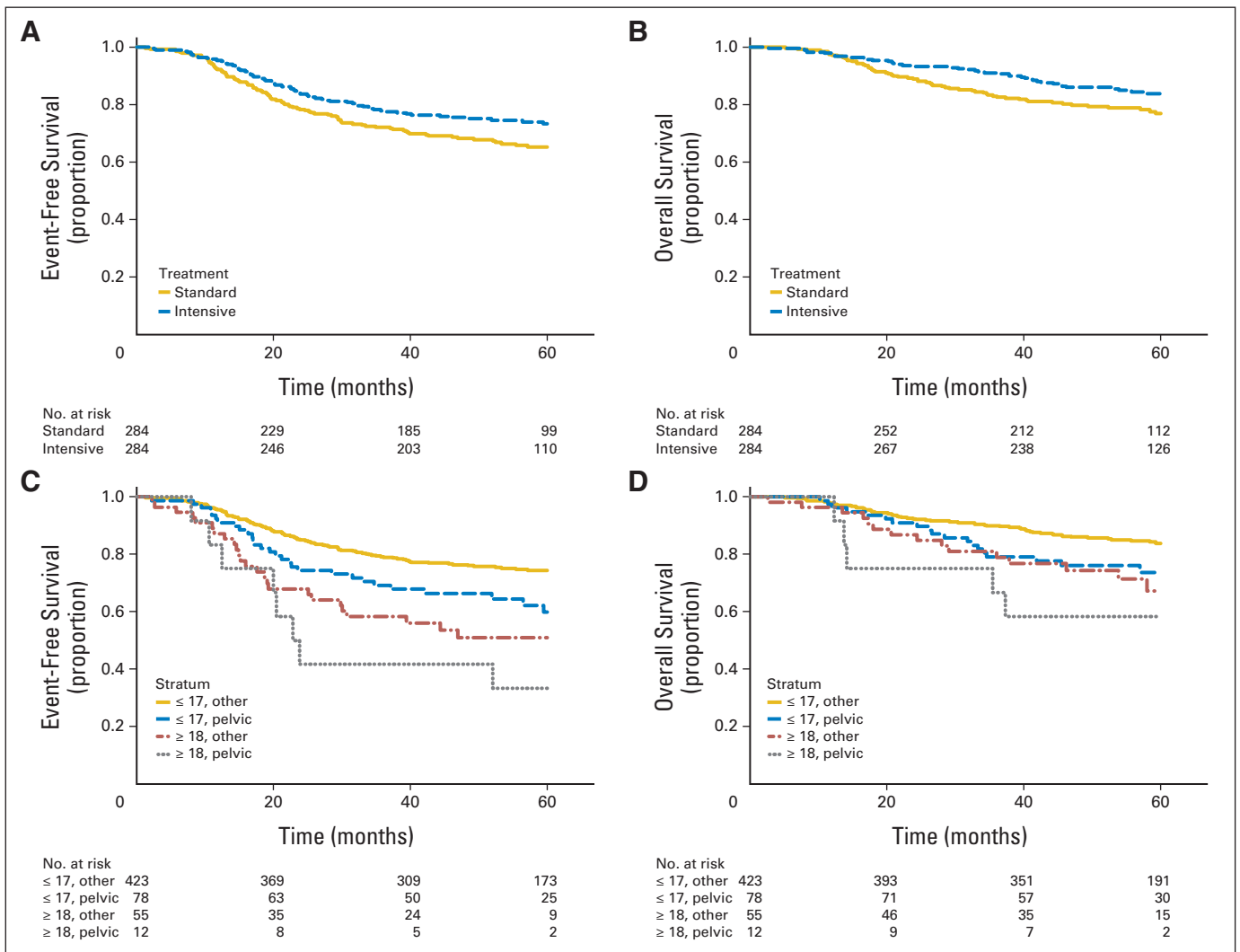

**Fig 3.** Kaplan-Meier plots of treatment outcome. (A) Event-free survival (EFS) according to the assigned treatment regimen. (B) Overall survival (OS) by regimen. (C) EFS and (D) OS, respectively, for the four strata, pooling the treatment regimens.

than for patients younger than 18 years (EFS at 5 years: 47% v 72%, respectively;  $P < .001$ ).

**Events Other Than Relapse**

There was one toxic death of a patient on regimen B who developed colitis and sepsis while neutropenic. One patient died of infection 40 months after enrollment, not associated with protocol therapy. One patient died in remission of a narcotic overdose 28 months after diagnosis.

Sixteen patients developed second malignancies, nine on regimen A and seven on regimen B ( $P = .62$ ). There were 11 acute myeloid leukemias (five on regimen A and six on regimen B), three osteosarcomas in radiation fields (two on regimen A and one on regimen B), and two lymphomas (both on regimen A).

**Toxicity**

Table 3 lists the grade 3 and 4 toxicities that were reported in at least 1% of the chemotherapy cycles in either regimen and all toxicities

involving fever or infection. No important differences were observed between the regimens.

Because grade 3 or 4 toxicities (especially infections and febrile neutropenia) usually require hospitalization, we compared hospital days in the two regimens. Patients receiving regimen A had a mean of  $5.0 \pm 4.25$  hospital days per cycle (median, 4 days), whereas patients on regimen B had a mean of  $5.1 \pm 4.26$  hospital days (median, 4 days;  $P = .43$ ).

**DISCUSSION**

These results demonstrate that reducing the interval between chemotherapy cycles from 3 weeks to 2 weeks using filgrastim improves the efficacy of treatment in patients with localized Ewing sarcoma family tumors. The improvement in EFS, from 65% at 5 years in the control arm to 73% in the experimental arm, represents a 22% decrease in the risk of recurrence. This was achieved with no increase in toxicity. The superiority of the intensified arm in overall survival just misses conventional statistical significance ( $P = .056$ );

Table 3. Toxicity

| Toxicity                       | Regimen A:<br>Standard Timing |     | Regimen B:<br>Intensive Timing |      |
|--------------------------------|-------------------------------|-----|--------------------------------|------|
|                                | No. of Cycles                 | %   | No. of Cycles                  | %    |
| Fever or infection             |                               |     |                                |      |
| Wound infection                | 35                            | 1   | 27                             | 0.7  |
| Febrile neutropenia            | 221                           | 6.2 | 266                            | 7.3  |
| Infection with neutropenia     | 166                           | 4.6 | 172                            | 4.7  |
| Infection without neutropenia  | 80                            | 2.2 | 72                             | 2    |
| Infection ANC unknown or other | 18                            | 0.5 | 13                             | 0.3  |
| Central line infection         | 51                            | 1.4 | 38                             | 1    |
| Colitis or typhlitis           | 9                             | 0.2 | 16                             | 0.4  |
| Total                          | 580                           | 16  | 604                            | 16.4 |
| Anorexia                       | 46                            | 1.3 | 48                             | 1.3  |
| Nausea                         | 69                            | 1.9 | 22                             | 0.6  |
| Vomiting                       | 39                            | 1   | 26                             | 0.8  |
| Stomatitis pharyngitis         | 80                            | 2.2 | 104                            | 2.9  |
| Hypokalemia                    | 54                            | 1.5 | 42                             | 1.2  |
| Days in hospital per cycle     |                               |     |                                |      |
| Mean                           | 5                             | 5.1 |                                |      |
| Median                         | 4                             | 4   |                                |      |

Abbreviation: ANC, absolute neutrophil count.

although relapsed Ewing sarcoma is rarely cured, patients often survive from several months to a few years after relapse, causing survival to lag behind EFS.

The improvement in prognosis seen with dose intensification by interval compression in Ewing sarcoma contrasts with the lack of improvement in the preceding pediatric intergroup study, in which the experimental regimen had fewer cycles with higher doses of alkylating agents in each, maintaining the traditional 3-week interval between cycles. The experimental arm had increased toxicity but no greater efficacy.<sup>14</sup> Two possible explanations for the difference are that our study increased the dose-intensity of all five chemotherapeutic agents used, rather than just the alkylating agents, and that a shorter interval between chemotherapy cycles provides greater efficacy.

The use of filgrastim in our study was critical. Investigators at the National Cancer Institute attempted interval compression in pediatric patients with sarcoma using sargramostim (granulocyte-macrophage colony-stimulating factor), rather than filgrastim, in a randomized controlled trial using a similar chemotherapy regimen. Sargramostim accelerated neutrophil recovery but seemed to delay platelet recovery, so that there was no acceleration of therapy or increased dose-intensity. Apart from more documented bacteremia in the sargramostim arm, there were no important differences in toxicity, EFS, or overall survival between the two arms.<sup>15</sup>

Our interval compression strategy follows Norton's dose density model<sup>16</sup> in maintaining doses while decreasing the intervals between them, thus also increasing dose-intensity. Dose-dense chemotherapy has had mixed results in other malignancies. In a randomized trial in pediatric acute myeloid leukemia, accelerated induction chemotherapy markedly improved EFS and disease-free survival, and the advantage persisted in all three postremission treatment arms.<sup>17</sup> In breast cancer, the C9741 study demonstrated that chemotherapy administered every 2 weeks was superior to chemotherapy administered every 3 weeks, with less toxicity, using both concurrent and sequential doxorubicin-cyclophosphamide-paclitaxel regimens.<sup>18</sup>

The European Osteosarcoma Intergroup study compared doxorubicin and cisplatin administered every 2 weeks versus every 3 weeks in patients with new diagnoses of localized osteosarcoma; the acceleration produced more good histologic responses but had no effect on EFS or overall survival.<sup>19</sup> In extensive small-cell lung cancer, accelerated chemotherapy similarly improved the response rate without affecting median survival or 2-year survival.<sup>20</sup> The Children's Oncology Group recently completed a single-arm prospective study testing accelerated chemotherapy in patients with high-risk rhabdomyosarcoma, and results are pending. Some other dose-dense approaches have reduced doses with decreased intervals, maintaining (rather than increasing) dose-intensity.

This was the third randomized North American study of Ewing sarcoma sharing a similar regimen, with alternating VDC and IE chemotherapy at standard doses administered every 3 weeks. The relevant arms of INT-0091 and INT-0154 had 5-year EFS rates of 69% and 70%, respectively, not significantly different from the 65% EFS rate in the current study ( $P = .33$  by log-rank test); overall survival is also similar ( $P = .44$ ). Although comparisons across studies are tempting, the reason we go to the trouble and expense of randomized controlled trials is that using historical controls (either formally or casually) is often misleading.<sup>21,22</sup>

Recently, Morales-Arias et al<sup>23</sup> reported expression of the granulocyte colony-stimulating factor (G-CSF) receptor and G-CSF in four of six Ewing sarcoma cell lines tested, as well as in each of 83 clinical Ewing sarcoma specimens. Although added G-CSF had no effect on growth of one of the cell lines in vitro, it more than doubled the volume of mouse xenografts compared with saline-treated controls, leading the authors to warn that G-CSF treatment may stimulate Ewing sarcoma growth in patients.<sup>23</sup> However, this is not apparent from the available clinical literature. Filgrastim received US Food and Drug Administration approval in February 1991, roughly halfway through the accrual to the INT-0091 Ewing sarcoma study,<sup>24</sup> and all patients received it in the INT-0154 study and AEWS0031. Comparing the comparable arms of the three studies (the experimental arm of INT-0091 and the control arms of the more recent trials), one finds almost identical EFS and overall survival, making an adverse effect of G-CSF on outcome unlikely.

Pegylated filgrastim (pegfilgrastim) came to market shortly before this study opened. Although it offers the advantage of a single injection rather than a series of 10 to 14 daily injections, we forbade its use because of a lack of experience with either interval compression or children. It now seems that pegfilgrastim also permits interval compression with similar effectiveness to filgrastim in children.<sup>25</sup>

Interval-compressed chemotherapy with VDC/IE and filgrastim is more effective in localized Ewing sarcoma than the same chemotherapy given at standard 3-week intervals, with no increase in toxicity. This could have implications for treatment of other childhood malignancies and other sarcomas in all ages.

#### AUTHORS' DISCLOSURES OF POTENTIAL CONFLICTS OF INTEREST

The author(s) indicated no potential conflicts of interest.

#### AUTHOR CONTRIBUTIONS

**Conception and design:** Richard B. Womer, Daniel C. West, Mark D. Krailo, Holcombe E. Grier, Scott Sailer, John H. Healey

**Provision of study materials or patients:** Richard B. Womer, Daniel C. West, Holcombe E. Grier, John H. Healey, John P. Dormans

**Collection and assembly of data:** Richard B. Womer, Daniel C. West, Mark D. Krailo, Paul S. Dickman, Bruce R. Pawel, Holcombe E. Grier, Scott Sailer, Aaron R. Weiss

**Data analysis and interpretation:** Richard B. Womer, Daniel C. West, Mark D. Krailo, Holcombe E. Grier, Karen Marcus, Scott Sailer, John P. Dormans, Aaron R. Weiss

**Manuscript writing:** All authors

**Final approval of manuscript:** All authors

## REFERENCES

- Nesbit ME Jr, Gehan EA, Burgert EO Jr, et al: Multimodal therapy for the management of primary, nonmetastatic Ewing's sarcoma of bone: A long-term follow-up of the First Intergroup study. *J Clin Oncol* 8:1664-1674, 1990
- Smith MA, Ungerleider R, Horowitz ME, et al: Influence of doxorubicin dose intensity on response and outcome for patients with osteogenic sarcoma and Ewing's sarcoma. *J Natl Cancer Inst* 83:1460-1470, 1991
- Smith MA: The impact of doxorubicin dose intensity on survival of patients with Ewing's sarcoma. *J Clin Oncol* 9:889-891, 1991
- Burgert EO Jr, Nesbit ME, Garnsey LA, et al: Multimodal therapy for the management of nonpelvic, localized Ewing's sarcoma of bone: Intergroup study IESS-II. *J Clin Oncol* 8:1514-1524, 1990
- Grier HE, Krailo M, Tarbell N, et al: Addition of ifosfamide and etoposide to standard chemotherapy for Ewing's sarcoma and primitive neuroectodermal tumor of bone. *N Engl J Med* 348:694-701, 2003
- Granowetter L, Womer RB, Devidas M, et al: Comparison of dose-intensified and standard dose chemotherapy for the treatment of non-metastatic Ewing's sarcoma (ES) and primitive neuroectodermal tumor (PNET) of bone and soft tissue: A Pediatric Oncology Group-Children's Cancer Group phase III trial. Proceedings of the International Society of Pediatric Oncology XXXIII Meeting, Brisbane. *Med Pediatr Oncol* 37:172, 2001 (abstr)
- Womer RB, Daller RT, Fenton JG, et al: Granulocyte colony stimulating factor permits dose intensification by interval compression in the treatment of Ewing's sarcoma and soft tissue sarcomas in children. *Eur J Cancer* 36:87-94, 2000
- Pocock S: *Clinical Trials: A Practical Approach*. New York, NY, John Wiley & Sons, 1983, pp 82-84
- Kaplan EL, Meier P: Nonparametric estimation from incomplete observations. *J Am Stat Assoc* 53:457-481, 1958
- Kalbfleisch J, Prentice R: *The Statistical Analysis of Failure Time Data*. New York, NY, John Wiley & Sons, 2002
- Prentice R, Kalbfleisch J, Peterson A, et al: The analysis of failure times in the presence of competing risks. *Biometrics* 34:541-554, 1978
- Fine J, Gray R: A proportional hazards model for the subdistribution of a competing risk. *J Am Stat Assoc* 94:496-509, 1999
- Bishop Y, Feinberg S, Holland P: *Discrete Multivariate Analysis*. Cambridge, MA, MIT Press, 1975
- Granowetter L, Womer R, Devidas M, et al: Dose-intensified compared with standard chemotherapy for nonmetastatic Ewing sarcoma family of tumors: A Children's Oncology Group study. *J Clin Oncol* 27:2536-2541, 2009
- Wexler LH, Weaver-McClure L, Steinberg SM, et al: Randomized trial of recombinant human granulocyte-macrophage colony-stimulating factor in pediatric patients receiving intensive myelosuppressive chemotherapy. *J Clin Oncol* 14:901-910, 1996
- Norton L: Evolving concepts in the systemic drug therapy of breast cancer. *Semin Oncol* 24:S10-3-S10-10, 1997 (suppl)
- Woods WG, Kobrinsky N, Buckley JD, et al: Timed-sequential induction therapy improves postremission outcome in acute myeloid leukemia: A report from the Children's Cancer Group. *Blood* 87:4979-4989, 1996
- Citron ML, Berry DA, Cirrincione C, et al: Randomized trial of dose-dense versus conventionally scheduled and sequential versus concurrent combination chemotherapy as postoperative adjuvant treatment of node-positive primary breast cancer: First report of Intergroup Trial C9741/Cancer and Leukemia Group B Trial 9741. *J Clin Oncol* 21:1431-1439, 2003
- Lewis IJ, Nooij MA, Whelan J, et al: Improvement in histologic response but not survival in osteosarcoma patients treated with intensified chemotherapy: A randomized phase III trial of the European Osteosarcoma Intergroup. *J Natl Cancer Inst* 99:112-128, 2007
- Sculier JP, Paesmans M, Lecomte J, et al: A three-arm phase III randomised trial assessing, in patients with extensive-disease small-cell lung cancer, accelerated chemotherapy with support of haematological growth factor or oral antibiotics. *Br J Cancer* 85:1444-1451, 2001
- Farewell V: Historical controls. *Pediatrics* 70:145-147, 1982
- Farewell V, D'Angio G: A simulated study of historical controls using real data. *Biometrics* 37:169-176, 1981
- Morales-Arias J, Meyers PA, Bolontrade MF, et al: Expression of granulocyte-colony-stimulating factor and its receptor in human Ewing sarcoma cells and patient tumor specimens: Potential consequences of granulocyte-colony-stimulating factor administration. *Cancer* 110:1568-1577, 2007
- Foot M, Boone T: Biopharmaceutical drug development: A case history, in Walsh G, Murphy B (eds): *Biopharmaceuticals, an Industrial Perspective*. New York, NY, Kluwer Academic Publishers/Springer, 1999
- Borinstein SC, Pollard J, Winter L, et al: Pegfilgrastim for prevention of chemotherapy-associated neutropenia in pediatric patients with solid tumors. *Pediatr Blood Cancer* 53:375-378, 2009