

KENNEDY III, JOHN THOMAS VANCE, M.F.A. *Creating Emotional Durability: Surface, Narrative, and Ritual*. (2016)
Directed by C. Tommy Lambeth. 125pp.

The concept of emotional durability seeks to connect users and objects through a deeper and evolving relationship. Products that engage the user and allow them to create a dialog and history between each other have a better chance of staying in the home and out of the landfill. This thesis aims to uncover ways to develop products that embody principles of emotional durability.

The thesis work itself evolved over time into four basic divisions. The first seeks to develop products that include a historical narrative and a surface that can evolve or develop a patina over time. During the second division understating the material properties of porcelain leads to the development that the mark of the maker's hand is instrumental in creating a dialogue with a user and invites them to develop their own history. The final division focuses on distilling forms to their simplest attributes allowing the mark of the maker to shine through, including the development of glaze techniques that create unique surfaces that encourage a user to develop a relationship with the product.

Kitchenware objects involved in the ritual of dining were chosen to explore the concept of emotional durability in product design. Products were created in porcelain, glass, and aluminum. Each showcases different attributes that can contribute to a product being emotionally durable

CREATING EMOTIONAL DURABILITY:
SURFACE, NARRATIVE, AND RITUAL

by

John Thomas Vance Kennedy III

A Thesis Submitted to
the Faculty of The Graduate School at
The University of North Carolina at Greensboro
in Partial Fulfillment
of the Requirements for the Degree
Master of Fine Arts

Greensboro
2016

Approved by

Committee Chair

DEDICATION

To my partner Robert Garner, thank you for encouraging me to follow my dreams
and supporting me through the process.

and

To my parents, John and Dale Kennedy, my brother Paul and his wife Terrell and
my extended family and friends for your unconditional love, support, and always
believing in me.

APPROVAL PAGE

This thesis written by John Thomas Vance Kennedy III has been approved by the following committee of the Faculty of The Graduate School at The University of North Carolina at Greensboro.

Committee Chair _____

Committee Members _____

Date of Acceptance by Committee

Date of Final Oral Examination

ACKNOWLEDGEMENTS

I would like to thank my committee members for their guidance and support through the thesis process. To my thesis chair, Tommy Lambeth, Who always encouraged me and continues to inspire me. He is a guiding light for all who have the opportunity to study with him. To Stoel Burrows who always pushes me to keep designing, even when I should be finished. His conversations helped me reach deeper meaning in my designs. To Jo Leimenstoll for her complete support for me as a student. Her guidance has kept me on track and she has continually pushed me outside of my comfort zone making me a stronger scholar. Finally, Nikki Blair who taught me everything I know about clay and for her willingness to work with me. Her ability to help me see my vision and guidance in creating my body of work was critical to the success of this thesis.

I would also like to thank UNCG, the Graduate School, and the Department of Interior Architecture for their support, both emotional and financial that has made my research possible. I would also like to thank my fellow interior architecture graduate students for their support and feedback along the way.

TABLE OF CONTENTS

	Page
LIST OF FIGURES	vii
CHAPTER	
I. INTRODUCTION	1
II. REVIEW OF LITERATURE	5
Emotional Design	6
Jonathan Chapman	6
Donald Norman	13
Product Design Precedents	14
Mark Braun	14
Tom Dixon	18
Felicia Feronne	22
Philippe Starck	25
Craft Technique	30
Ceramics	30
Glass	35
Historical Reference	36
Historic Preservation	38
Conclusion	40
III. METHODOLOGY	43
The Heuristic Approach	43
Division I	47
Production Process	66
Division Ib	72
Division II	79
Division III	84
Division IV	92
IV. ANALYSIS	97
V. CONCLUSION	101
REFERENCES	106

APPENDIX A. IMAGE SOURCES.....	111
APPENDIX B. BODY OF WORK.....	113

LIST OF FIGURES

	Page
Figure 1. Bowl Set 1 by: Mark Braun	16
Figure 2. Drinking Set No. 283 Gold Edition by: Mark Braun.....	17
Figure 3. TS 283 Fortune by: Mark Braun	18
Figure 4. S Chair by: Tom Dixon	19
Figure 5. Grab Chair by: Tom Dixon.....	21
Figure 6. Copper Grab Chair by: Tom Dixon	22
Figure 7. Revolution Series by: Felicia Ferone	23
Figure 8. Lift Series by: Felicia Ferone	24
Figure 9. AHN Table by: Felicia Ferone	25
Figure 10. Louis Ghost Chair by: Philippe Starck	26
Figure 11. Juicy Salif by: Philippe Starck.....	27
Figure 12. Napkin Sketch by: Philippe Starck.....	29
Figure 13. Heuristic Method Diagram	45
Figure 14. Bowl Design Process.....	50
Figure 15. Bowl Design Process.....	51
Figure 16. Bowl Design Process.....	52
Figure 17. Bowl Design Process.....	53
Figure 18. Vessel Design Process.....	54
Figure 19. Vessel Design Process.....	55

Figure 20. Vessel Design Process.....	56
Figure 21. Vessel Design Process.....	57
Figure 22. Peppermill Design Process	58
Figure 23. Peppermill Design Process	59
Figure 24. Peppermill Design Process	60
Figure 25. Peppermill Design Process	61
Figure 26. Peppermill Design Process	61
Figure 27. Peppermill Design	62
Figure 28. Teapot Design Process	63
Figure 29. Teapot Design Process	64
Figure 30. Teapot Design Process	65
Figure 31. Teapot Design Process	66
Figure 32. 3D Printed Prototype	68
Figure 33. 3D Printed Prototype	69
Figure 34. 3D Printed Prototype	71
Figure 35. Chandelier Line Drawing	74
Figure 36. 3D Printed Chandelier Parts.....	75
Figure 37. Chandelier Process	76
Figure 38. Chandelier Process	78
Figure 39. Chandelier Patina.....	79
Figure 40. Slip Cast Vessel	81

Figure 41. Carved Porcelain Vessel	82
Figure 42. Carved, Glazed, Porcelain Vessel.....	83
Figure 43. Silicone Mold Making Process.....	85
Figure 44. Kiln Casting Glass Process	87
Figure 45. Aluminum Casting Process	89
Figure 46. Aluminum Casting Process	91
Figure 47. Aluminum Casting Failure	92
Figure 48. Slab Building Process.....	93
Figure 49. Slab Building Process.....	95
Figure 50. Slab Building Process.....	96

CHAPTER I

INTRODUCTION

As humans we need regular nourishment to function. Normally this is accomplished through the task of eating three meals a day. Although many skip breakfast, others have a small bite with coffee at home. Lunch is often with friends or co-workers during a lunch hour. However, dinner is a time when our families come together to discuss our days and share a meal with each other. The process of sharing meals with others can also be called dining. Dining is more than eating; dining is a ritual embedded with meaning and emotion. Dining is a process of presentation, timing, sequence, and celebration. When we dine out, the choreography of a meal is prominent, every last detail is thought of and the presentation of food becomes an art form in itself. In the home we have our own set of rituals associated with dining. Multiple sets of china, glassware, and utensils are often present, with many homes having one set for daily use and another set for formal occasions. Meals are prepared with love and the best ingredients we can allow. Daily meals give us refreshment and celebratory meals additionally give us something to look forward to. Some celebratory meals are full of pomp and circumstance; think Thanksgiving and Christmas, where we pull out all the stops and use the good stuff: china, crystal, and silver. Whether we dine in the kitchen or dine in the dining room, dining is a daily ritual

for us all. Our lives are comprised of memories of these rituals, the items we celebrate them with, and the places where they occurred.

In historic preservation, place memory and place association are used as a way to connect people to historic ideas or places, encouraging the end user to create their own history or associate their history with a concept or place, inviting them to own a piece of the story. In a culture where emphasis is placed on building new eco-friendly structures we often forget that the most sustainable building is the one already standing. To some these structures have a soul; they show a time worn patina and evoke a nostalgic feeling. These attributes contribute to the emotional connection felt with these buildings and are just one reason why people choose to save old places.

This story is also present in household objects. Many people, especially those from the southern United States, place value on cooking utensils of their ancestors, especially with respect to cast iron cookware. We tend to collect cast iron skillets. Cast iron cookware is inexpensive, durable, and gets better with age through the development of a patina. Cast iron pans are even passed down through the family in wills. Cast iron pans remind people of their childhood and going over to grandmother's for fried chicken on Sunday. There is a nostalgia for cast iron pans that is associated with a place, a memory, and a smell. This nostalgia can also be seen as an emotional attachment to the object.

This thesis aims to explore the creation of kitchenware products that help us celebrate the act of dining: products that we love as much as those whom we

share meals with; objects that elevate our daily dining ritual into a more meaningful experience; a group of objects that we want to grow old with, cherish, and pass down to our children; objects that are emotionally durable.

Designing new objects that have this type of appeal can theoretically be seen as creating emotional durability. This concept allows for the design of new objects that individuals want to keep as family heirlooms, rather than objects that are replaced by tomorrow's newer object. This practice creates less waste, less recycling, and ultimately uses less energy. Author Jonathan Chapman breaks down the reasons why people love or abandon products. In his book *Emotionally Durable Design: Objects, Experiences, and Empathy*, he evaluates specific criteria which can help contribute to a more successful emotionally durable design. He also suggests how we as designers can help the end user develop a dialogue with a product, and ultimately how we can design to encourage a consumer to evolve with an object.

Two specific areas of Chapman's research inspired the exploration that this thesis focuses on, narrative and surface. Chapman's research has shown that 47% of respondents had a positive association to products that included these areas as a design foundation. Heuristic methodology was used to carry out my research and utilized Chapman's criteria on surface and narrative as a design guideline. A collection of tableware was created through the course of two studio classes, two ceramic classes, a glaze class, and a workshop focusing on glass and metal at Penland School of Crafts. The body of work created for

this thesis centered on the design of tableware using an iterative design process that integrates Chapman's theories on emotional durability, particularly his ideas about surface and narrative.

CHAPTER II

REVIEW OF LITERATURE

The theoretical basis for this thesis includes four primary areas of thought: emotional design concepts, craft techniques, precedent forms, and historic preservation principles. Emotional design aims to engage the user for greater lengths of time, making it difficult for them to part with a designed object. Some core principles of historic preservation encourage the use of authentic materials and the celebration of a sense of place. These ideas tie closely with the concepts of emotional durability and can also help inform the design process.

My undergraduate design education placed value in beginning a project with precedent studies. Precedent studies educate the individual on what is being produced in the world and is one beginning to the ideation process. Various designers' web pages, products, and books on or by them have been used for these precedent studies, the most influential being included in this review.

Midway through my research a process shift occurred that moved me from having my designed products produced by other artisans to producing them myself. This production process required additional research in materials and methodologies, primarily in ceramics and glass. It has resulted in a very broad and diversified review of literature that has continued throughout the

research process, ultimately, informing the process at every stage, not just in the beginning.

Emotional Design:

Jonathan Chapman

Jonathan Chapman has written multiple books on emotionally durable design, with his second edition of *Emotionally Durable Design: Objects, Experiences, and Empathy* being the most comprehensive. In this text Chapman delves into the reasoning behind why individuals love or abandon objects. He leads the reader through this journey in seven chapters: the progress illusion, consumer motivation, attachment to objects, authors of experience, sustaining narrative, de-functioning utopia, and real-world feasibility.

Chapman begins with the progress illusion where he discusses the false sense of moving forward, issues that are created from our modern world, and how it relates to sustainability. When speaking about consumption and waste he states the following:

The rampant consumption and waste of natural resources so prevalent in the developed world is a legacy of modern times, born largely from the inappropriate marriage of excessive material durability with the fleeting product-use careers. (Chapman, 10)

Chapman posits that the overdesign of objects renders them more quickly obsolete. The increased use of materials for a better quality is not warranted by such a quick phase out time, or as he later describes, planned obsolescence.

Additionally he feels that objects which are created with recycling in mind help to create more waste. The idea that they are recyclable signals to the consumer they can be thrown out with little environmental impact. It is in this chapter that Jonathan Chapman introduces the concept of emotional durability:

Emotionally durable design explores the idea of creating a deeper, more sustainable bond between people and their material things. The ultimate aim is to reduce the consumption and waste of resources by increasing the durability of relationships between consumers and product.. It tackles the challenge of weaning people off their desire for the new, and it helps to shape new sustainable business models... (Chapman, 21)

What is it about a product that makes us love it and allows us to form a bond or a relationship with it? I find it interesting that Chapman talks about increasing the durability of the object through a developed relationship. Understanding what drives a consumer to purchase a replacement object rather than keep an object is critical to this concept.

Consumer motivation is based on what Chapman calls “natural consumption in the developed world.” We have amazing technology that allows us to process and accomplish tasks at a much higher rate than even 50 years ago. The rapid increase in output leaves us with a great deal of free time, which we fill by buying things, or consuming. Chapman believes that consumption is:

an endless personal journey towards the ideal or desired self that, by its very nature, becomes a process of incremental destruction: this take-up and subsequent displacement of matter enables the consumer to perceive their individual evolution and development as it occurs ontologically. (Chapman, 32)

Thus, the collection of objects becomes an extension of our own self and the objects we choose to acquire must represent part of who we are. However, what happens when our personal views change, how does that affect the products we consume? Here lies the problem... “Consumer aspirations continually evolve whereas products are hopelessly frozen in time.” (Chapman, 61). The solution to less consumption is figuring out how to un-freeze these objects and how to keep the human intrigued.

The emotional attachment to objects is more about meaning than function, and most importantly about ideas. Chapman also leads us to believe that “durable connections between users and their mass-manufactured counterparts are very rarely forged.” (Chapman, 70). The primary reasoning behind this lies in constantly increasing expectations that are portrayed by the manufacturer. Every object will soon have a replacement that is new and improved, has better features, is faster, will help make our lives so much easier and more efficient. The objects that we consume do so many tasks for us we do not have to think about what we are doing anymore.

Chapman discusses the idea of rituals and uses the act of playing a record as an example. There is a ritual associated with playing a record. The record is fragile and must be properly stored so it does not warp. Upon placing the record on the turntable a special duster is used to remove dust from the surface of the record. Skipping this step may leave the record with scratches, forever changing the listening experience. Once the needle is placed on the

record we are rewarded with the magic of sound. By partaking in this ritual we pay more attention to the music and enjoy a richer experience. The record will not automatically repeat and depending on the record player once the record finishes playing the needle will continue to spin and make a scratchy noise until we interact with the machine again.

Later developments such as the cassette tape and the cd player have integrated more autonomy into the process, requiring less from the listener. In turn we pay less attention to the music and according to Chapman, have a less rich experience. This streamlining has “inadvertently stripped the charm, mystery, and wonder out of everyday material encounters.” (Chapman, 84) The introduction of what he calls fuzzy interaction can re-introduce us to the more traditional object interactions. What are fuzzy interactions? They “present users with complex, artful scenarios that must be learned and mastered...” (Chapman, 83). This idea of forcing us to slow down allows “us to think, experience, and re-evaluate our assumptions about the way things are in the ever changing world.” (Chapman, 83).

A personal experience of this for me is the ritual of making espresso in the morning. There is an art to pulling the perfect shot, having bold flavor, eliminating bitterness, and seeing a beautiful crema form. The Francis Francis x1 machine will allow a user to accomplish this task with ease. However; there are a litany of minor adjustments which must be made to successfully pull this perfect shot of coffee. The most important part is the grind of the coffee; too fine

and you end up with an oily shot, too coarse and the water pours through too quickly, leaving you with no flavor. What they don't tell you when you buy this espresso machine is that you also need a coffee grinder that is just as expensive and that store ground espresso just will not work. Once the stars have aligned a perfect shot of espresso can be pulled, but if you duplicate the steps tomorrow you may or may not get the same result.

As our lives become more and more fast paced, the idea of time becomes the new luxury commodity to have: time to sit down and read a book, time to visit with friends over a home cooked meal, time to enjoy rituals. For Chapman the ritualistic experiences of sharpening a knife on a stone or refilling a fountain pen with ink assists the user in developing a relationship with an object, and creating a meaningful user interaction. The same idea can be seen in items that change with our own use, ones that develop a patina over time. The iPhone 6 leather case manufactured by Apple is an example of this. The case mimics the lines and design of the phone and is crafted in aniline dyed leather. Soaking the hide in a solution rather than just spraying a coating of color on top dyes this type of leather. This is advantageous because scratches will be the same color as the hide, whereas in a top dye situation the scratch will be the original color of the hide. The choice of this material allows the case to develop a rich patina over time based on the users interactions. Oils from the hands darken areas of constant touch. Scratches, water marks, and bashed corners add another textural element that gradually melds back into the surface, creating a rich,

evolved patina. This evolution of surface is user-dependent and will vary from case to case. Chapman would say the user is the author of this experience; he/she has participated in making the object more desirable. This process creates a connection between user and object that has both empathy and emotional durability.

For Chapman, this continued surface development creates a sustaining narrative. This narrative is essential in creating emotional durability between object and user. He uses the example of denim jeans:

You have a close relationship with your jeans. Your jeans are a second skin, faded and shaped and ripped and bulged by your experiences. They are lived in. After a party they smell like a party. They are a familiar old friend, a repository of memories, a comfort blanket. (Chapman, 116)

Jeans tell a story, they change and evolve, and get better with time. The story they tell gets richer and more developed the longer you use them. This is what we want from the products we buy. We wear them and they represent where we have been and what we have accomplished. The problem with most goods today is they “are like stories with an incredible opening line, but they just continue repeating it throughout (Chapman, 122).” They do not evolve and get better with use, they do not reward the user for interacting with the object, and, consequently, they quickly fall out of favor with the user. Chapman quotes UK designer Julia Lohman: “when communicating through objects the meaning is created through the materiality of the object. The materials become words; the

design becomes the syntax.” (Chapman, 122) Lohman reinforces the idea that the materials you choose can have a profound impact on a design. Denim jeans are not the same if they are not made with authentic indigo dyed denim material.

Authenticity is crucial for a product to be successful. The patina that develops on the iPhone case or the pair of blue jeans is real, it is not a fake patina. Adding patina to create a false sense of history can be a precarious decision. Chapman states “patina plays a crucial role in both the mapping and portrayal of age and must come with carefully authored appropriateness to the genre...” (Chapman, 133) His ultimate message is that if a patina is desired, utilize a material that supports that development over time rather than create a false story.

Chapman distills his research into a six point framework “providing product designers with distinct conceptual pathways through which to initiate engagement with salient issues of emotional durability and design, presenting a more expansive, holistic understanding of design for durability - both in terms of paradigm and of the language used to articulate it.” (Chapman, 175). The six pathways are:

1. Narrative: users share a unique personal history with the product, this often relates to when, how and from whom the object was acquired.
2. Detachment: users feel no emotional connection to the product, have low expectations and thus perceive it in a favorable way due to lack of emotional demand or expectation.
3. Surface: the product is physically aging well and developing a tangible character through time, use and sometimes misuse.

4. Attachment: users feel a strong emotional connection to the product due to the service it provides, the information it contains and the meaning it conveys.
5. Fiction: users are delighted or even enchanted by the product as it is not yet fully understood or known by the user, these are often recently purchased products that are still being explored and discovered by the user.
6. Consciousness: the product is perceived as autonomous and in possession of its own free will; it is quirky and often temperamental, and interaction is an acquired skill that can be fully acquired only with patience. (Chapman 175)

His research breaks these six approaches down by percentage of occurrence with study participants: narrative (24%), detachment (23%), surface (23%), attachment (16%), fiction (7%), and consciousness (7%). He concludes by saying that for objects to be emotionally durable “such objects are designed for empathy and are created in an artful way, engendering powerful emotional attachments, rich evolving narratives, intense user experience and a sustained element of uncertainty and fiction.” (Chapman, 180)

Donald Norman

Like Jonathan Chapman, Donald A Norman has written several books about emotional design, with most of his research being focused on human centered design. In the book *Emotional Design* he explores why we love and hate everyday objects. His research gives us three levels of design: visceral, behavioral, and reflective. At their essence, visceral is what we do as humans, trying to fit into our environment; Behavioral is about use, and Reflective is about

message, culture, and meaning. Norman's approach is more psychological than Chapman's. Norman states that:

The objects in our lives are more than mere material possessions. We take pride in them, not necessarily because we are showing off our wealth or status, but because of the meanings they bring to our lives. A person's most beloved objects may well be inexpensive trinkets, frayed furniture, or photographs and books, often tattered, dirty, or faded. A favorite object is a symbol, setting up a positive frame of mind, a reminder of pleasant memories, or sometimes an expression of one's self. And this object always has a story, a remembrance, and something that ties us personally to this particular object, this particular thing. (Norman ,6)

This phrase is the root of the concept of emotional durability. Norman's ideas are at the core of emotional design, yet his research is more focused on people and their emotions. This thesis will reference Norman's works; however, the thesis is less about researching people and more about creating products for people.

Product Design Precedents:

Mark Braun

Since 2006 Mark Braun has been principle in ing a design studio in Berlin, Germany. Like many other product designers he works with companies in collaboration to design and manufacture. He works across multiple design areas, furniture, products, lighting, and special projects. His work has won a litany of awards, is exhibited in museums, and extends to the everyday consumer. His line of products initially caught my eye, many being produced in clay, glass, and wood, all of which I hope to explore in my own work.

Most provocative to me is Bowl Set One, which Mark describes as “a tea set with special haptic qualities (Figure 1). Sensitive pleasure of tea drinking is supported by materials innovation.” (Braun, 2016).

This tea set is made from white and black porcelain with the addition of a strip of micro glass dots. These micro dots provide the haptic element to the user while making the set easier to hold. From an emotional durability standpoint, each of these dots is different and each tea sets texture will vary slightly allowing the consumer to form a bond with the objects. The more the consumer uses the tea set the more familiar they will become with the haptic surface, resulting in dialogue between user and object.



Figure 1. Bowl Set 1 by: Mark Braun

This tea set is made from white and black porcelain with the addition of a strip of micro glass dots. These micro dots provide the haptic element to the user while making the set easier to hold. From an emotional durability standpoint, each of these dots is different and each tea set's overall texture will vary slightly, allowing the consumer to form a bond with the objects. The more the consumer uses the tea set, the more familiar they will become with the haptic surface, resulting in dialogue between user and object.

A second product group is Drinking Set No.283 gold edition, originally created as a collaboration between Braun and Lobmeyr crystal for Vienna Design Week 2010 (Figure 2). The original collection featured blown crystal carafes, which had etchings of various glaciers, lakes, and rivers to celebrate the simplicity of water.



Figure 2. Drinking Set No. 283 Gold Edition by: Mark Braun

Later editions have been commissioned. One for the Thames river in London by Libby Sellers Gallery (<http://www.libbysellers.com/exhibitions/23/overview/>) and a second for the Hudson River in New York by Stillfried Wien (<http://www.stillfried.com/products/fortune-series>). Each of these carafes invites a user to relate to a sense of place. This carafe has evolved into a drinking set: “*TS 283 Fortune* is a drinking set made in crystal glass, based on two essential items: carafe and tumbler (Figure 3). Highlighting the value of drinking water and

the product itself, each item features an engraved golden dot as the calibration mark.” (Braun, 2016). In addition to a water glass, a wine glass and beer glass have been designed to accompany the grouping. Each of these objects features an engraved golden dot, which signifies the appropriate amount of a beverage to be served.



Figure 3. TS 283 Fortune by: Mark Braun

Tom Dixon

In 1975 at the Holland Park Comprehensive, Tom Dixon began his exploration of material and manufacturing. By the mid 1980's he had designed the iconic S-Chair, which was based upon a sketch of a chicken, and

manufactured by the Italian firm Cappellini (Figure 4). Still in production today, this chair can also be seen in the permanent collection of the Museum of Modern Art in New York.



Figure 4. S Chair by: Tom Dixon

My interest in Dixon's work originated with his strong desire to understand a material as part of his design process, as well as his non-traditional approaches to design. Both of these attributes can be seen in the Polystyrene Grab chair and the resulting studio piece, the CU29 chair produced exclusively for Moss.

The Grab Chair was produced in collaboration with EPS Packaging Group for the 2006 London Design Festival (Figure 5). Dixon stated; “For many designers, the opportunity to make a mass-produced plastic chair will never come. Too high an investment, too big a commitment in stock and too much risk for an industrialist to take.” (Dixon, 2016). He partnered with EPS Packaging group as a sponsor, to fund the creation of the chair. EPS is expanded polystyrene, which is what most people might think of as Styrofoam. The material is strong, lightweight, and resistant to water intrusion. Commonly, EPS is commonly used in the building trades as insulation. (<http://insulationcorp.com/eps/>). 500 of the chairs were placed in Trafalgar Square in London. As a way to make “design available for all” the chairs were given away for free. (Dixon, 2016). By making the chair available for free there was no risk in creating an innovative design, no risk in sitting on a huge inventory, and as Dixon says, no risk in a “pathetic standard return in royalties from the typical deal in this industry.” (Dixon, 2016)



Figure 5. Grab Chair by: Tom Dixon

The CU29 chair was produced in collaboration with Moss as part of their 2007 Heavy Metal Show in Miami (Figure 6). The Grab Chair was the basis for this project that sought to add another layer to the chair; using copper as a surface material. The polystyrene chair was submerged in a bath in a process best explained by Moss:

During full immersion in a liquid bath containing pure copper crystals, the textured surface of the chair's intricately curved industrial form attracts the honeycombed-patterned crystals, resulting in a unique copper cladding, extremely strong yet surprisingly lightweight. (Moss, 2016).

Growing copper on a chair is certainly an un-orthodox way to produce a chair. What results is a lightweight chair with a surface unlike any other. The copper undulates through the polystyrene surface in an uncontrolled way, making each

chair unique. Left untreated and in a raw state the surface will develop a rich patina over time. Areas touched often stay a bright copper color and those untouched darken and oxidize.



Figure 6. Copper Grab Chair by: Tom Dixon

Felicia Feronne

Felicia Feronne is a designer from Chicago, Illinois. She creates Products, interiors and exhibits with “European influences, minimalist aesthetics, mastery of proportion, and meticulously considered details.” (Feronne, 2016). I was initially drawn to her Revolution line of glassware (Figure 7).



Figure 7. Revolution Series by: Felicia Feronne

For her “the collection is comprised of 6 tabletop vessel designs combining typologies of tumbler, stemware, and bowls. The Revolution Collection redefines the landscape of the table as the contents seem to defy gravity, be it water, wine, champagne, gelato, or soup.” (Feronne, 2016).

The LIFT SERIES is a sub category of her Revolution Collection that utilizes copper to create a minimalist set of elevated trays with holes in the middle (Figure 8). Using them to display fruit challenges the viewer’s idea of a fruit bowl since the fruit could fall through the central hole. Other suggested uses include a drink tray, hors d’oeuvre serving tray or a plant stand.



Figure 8. Lift Series by: Felicia Ferone

The idea that one object can perform multiple tasks appeals to me, and even more appealing is the idea of challenging the user to use objects in a non-standard application. A broader look at her work illustrates the ideas of re-thinking how objects work as well as removing aspects of products to re-imagine their form and function.

Her AHN furniture collection features simple steel orthogonal forms that are filled with ovoid shapes to create tops, sides, and bottoms; presenting us with a familiar object that challenges our expected thoughts (Figure 9).



Figure 9. AHN Table by: Felicia Ferone

Philippe Starck

As one of the most prolific, contemporary designers, Philippe Starck is a powerhouse. “Subversive, ethical, ecological, political, humorous... this is how I see my duty as a designer.” (Starck, 2016) Finding an individual who has not heard of this designer or seen his work may be a difficult task. By his own accord he has created over 10,000 designs. His website describes him as a humble designer who has

a vision: that creation, whatever form it takes, must improve the lives of as many people as possible. His practice is multidisciplinary and includes furniture, lighting, vehicles, architecture, interiors, industrial design, and artistic management. (Starck, 2016)

This statement illustrates that he believes good design can be applied to any subject matter. The Louis Ghost chair created for Kartell, and the Juicy Salif juicer for Alessi were my first introductions to his work (Figure 10, 11).



Figure 10. Louis Ghost Chair by: Philippe Starck



Figure 11. Juicy Salif by: Philippe Starck

I was originally drawn to the playfulness embodied in his work and grew to respect his pieces because of their functionality and exceptional level of craft. Further evaluation of his work and process revealed that he is a master of re-interpreting the past. Re-interpreting historical pieces while challenging what can be mass-produced has resulted in incredible design and production advances. Kartell, the Italian manufacturer of the Louis Ghost chair, claims that the “the

distinctive detail of the medallion-shaped back and the arms were quite a considerable hurdle to clear.” (Kartell, 2016). In fact the chair is produced in a single mold through polycarbonate injection. The chair has zero joints which is integral to the strength of the chair. The material, polycarbonate, is shock, weather, and scratch resistant according to the manufacturer. Kartell claims to have sold over 1.5 million units of the chair, making it wildly successful. In 2002 the chair celebrated it’s 10th anniversary and Starck commented:

The universal success of the Louis Ghost chair does not come from its design but from collective memory. The Louis Ghost chair was produced by our collective subconscious and it is only the natural result of our past, our present and our future.(Kartell, 2016).

A second Starck-designed object that has been much debated is the Juicy Salif juicer, as the form is more important than the function. His idea came while eating calamari in Capri while waiting for a waiter to bring him lemon. His idea was born; and he worked through some quick ideation sketches on his placemat (Figure 12). Looking at his sketches the viewer sees a progression across the placemat of a squid turning into the iconic juicer we see today. For the 10th anniversary of the juicer, Alessi had 10,000 gold plated versions made, strictly for show, since the acid in the citrus juice would deteriorate the gold surface. Even the standard polished aluminum version comes with strict instructions to immediately rinse the juicer under water after using to prevent damage to the surface. One debate over this juicer has been whether it really is a juicer; since

you should not, or should very carefully, use it. Starck's own response was that it was *"not meant to squeeze lemons"* but *"to start conversations"* (Norman, 114)



Figure 12. Napkin Sketch by: Philippe Starck

Craft Technique:

Ceramics

Working with ceramic presents a new set of design challenges. All clay bodies have their own characteristics, color, shrinkage, and firing range. Some bodies are better for hand building, while others are better for wheel throwing. Each of these techniques is a unique art form. A third mode of crafting ceramic artifacts, slip casting, was identified as the most logical approach to replicating 3D printed objects for this thesis.

Initial research into the slip casting method of production identified Peirce Clayton's book *The Clay Lover's Guide to Making Molds* as a recourse to begin with. His thorough explanation of different types of molds and their production process was an immersive introduction. All aspects of mold making were covered, from object design to appropriate ways to mix and pour plaster. There is an incredible amount of technical data in the text that is very specific for different materials and processes. This information is important as it helps cut out a lot of errors that can commonly be made during the process. As important as the mold-making process is to my body of work, the understanding clay bodies is even more important.

Like Clayton's book the *Ceramics Monthly's Guide to Materials and Glazes*, edited by Jessica Knapp, is also packed with technical information. Commercial prepared versions of clay and glaze are available, however; they are often more expensive. Creating clay bodies and glazes from raw materials gives

artists a much greater level of control over the final product, as well as helps them to understand why results occur the way they do. This text is extremely useful in the development of clay bodies and glazes. A great deal of time is spent explaining the differences in the raw materials, how they interact with each other, and some common results to expect. Some materials, like lead, can be toxic to living creatures, and safety precautions are explicitly laid out through the book. After a thorough introduction to the materials the book goes into studio application and firing possibilities. Glaze recipes and techniques are covered in the remaining half of the book, which is divided according to low, mid range, and high fire. These recipes and techniques are based on kiln temperature and kiln atmosphere.

The UNCG ceramics studio has electric kilns that fire up to approximately cone 8, and gas kilns that fire up to cone 12. Each of these sets of kilns also fire with different atmospheres, and in this studio electric kilns are an oxidation atmosphere and gas kilns are a reduction atmosphere. However; it is possible to do reduction firing in an electric kiln and oxidation firing in a gas kiln. These atmospheres have an immense impact on glazes, and it is important to understand the chemical make up of glazes and clay bodies to begin to understand what results can be expected. Each kiln will have its own characteristics and no two will fire exactly the same, which will alter results. Testing glazes in specific kilns is the best way to see specific results and

understanding that different firings may show alternative outcomes. The number of variables in working with clay is monumental.

Understanding and mastering glaze is often a lifetime endeavor for a ceramic artist. Four texts have given insight to the extraordinarily complex art of glazing. *The Glaze Book* by Stephen Murfitt is primarily a visual glaze catalog. A small introduction on materials, techniques, safety, and firing ranges provides a brief synopsis of these attributes. The recipes are broken down into clay body type, such as earthenware, stoneware, and porcelain. “Earthenware is usually fired to temperatures below 2174 °F and within the range of 1742-2102 °F. The clay remains somewhat porous and open in structure (Murfitt, 24).” This structure means the finished product is softer or less dense than a higher fired clay. Stoneware is “a vitrified (non-porous) ware that matures within the temperature range of about 2192-2372 °F. (Murfitt, 120)” This higher temperature range makes the clay more-dense and impervious, making the products produced from it more durable. The third clay body used in this book is porcelain, which is known for its bright white color and translucency. The firing range for porcelain “is higher than for stoneware: 2372-2642 °F.” (Murfitt, 200). Within each of these clay body categories glazes are pictured with the recipe used to create the glaze. The glaze recipes are organized by color and by kiln atmosphere. This makes it easy to select glazes to use.

A second text, *Glaze, The Ultimate Ceramic Artist’s Guide to Glaze and Color* by Brian Taylor and Kate Doody showcases a wide range of artists, their

works, techniques, and their glazes. This text appears to be full of amazing information. However; upon close inspection many of the examples utilize commercial clay bodies and commercial glazes. While this may be much more approachable for some artists, there is less meaningful information to learn from. This text was initially chosen for the inclusion of potter Adam Field and some of his glaze recipes, which are included in the book. The text does offer technical descriptions, which include clay body, kiln atmosphere, and firing temperature. This is helpful when developing custom glazes as it gives insight into how materials will work together and what the results could be.

Potter John Britt has written *The Complete Guide to High-Fire Glazes: Glazing and Firing at Cone 10*. A similar approach was taken in this text, where a specific potter's work is showcased with his/her techniques and glazes explained. Not all of the pieces to the puzzle are always presented which leaves the reader needing additional information to be successful. For example, many of the works in the book feature layered glazes to create rich surfaces with beautiful effects. One of the glaze recipes will be provided and discussed; yet the second glaze is not mentioned and the recipe not provided. This can prove very frustrating. Charts of various types of glazes are shown side by side, enabling an evaluation of their constituent materials. Visual examples of each glaze are also included.

The most informative graphs we see correspond with particular oxides or colorants that are used in a recipe. These elements will have a range in which

they best perform or show their best color. The accompanying graph shows us Al_2O_3 (Alumina oxide) along one axis and SiO_2 (Silicon dioxide) along the other axis. "Alumina oxide is the primary stabilizer, and the silicon Dioxide is the primary glass-former." (Britt, 14) These two materials allow a glaze to melt or become glass like and be stable in their position on a pot so that they do not melt off of the pot. Showing the ranges that the recipes perform best allows the artist to make changes based on the properties they are looking for in a finished glaze. The extensive collection of information and recipes in this book enable readers to develop glazes of their own, knowing what the end result should be. This text is specific to high fire glazes and results would not be the same if firing at low temperatures.

Developing one's own glazes may be the best solution for a potter to have complete control over their work. Returning to the *Ceramics Monthly* book, the sections on glaze are the most thorough of all the texts explored. The approach is much more scientific and material driven. Glaze examples are shown with the corresponding recipe. In addition to this, variations are shown with different percentages of materials included. Typically each recipe shows four variations, allowing the reader to see how the glazes change, giving an incredible amount of knowledge to work with. Understanding how clay bodies and glazes interact with each other is critical to understanding what can be created.

Glass

In preparation for a two-week glass casting workshop at Penland School of Crafts in Penland NC, I sought reference to begin to understand the glass casting process. Glass casting is accomplished by using the lost wax technique, which is also used for casting metals. In this technique a positive is created in wax. The positive is encased in a plaster investment, which is built up of multiple thin layers of plaster, until a very thick shell is created. The wax positive is then steamed or melted out of the investment, leaving a negative to fill with glass. Once filled with molten glass and cooled, the plaster investment is broken off to reveal a glass version of the initial wax positive. Two texts were consulted, *Mould Making for Glass* by Angela Thwaites and *Warm Glass, A complete Guide to Kiln-Forming Techniques: Fusing, Slumping, Casting* by Philippa Beveridge, Ignasi Domémnech, and Eva Pascual. These two texts provided an exhaustive discussion on the processes used for working with glass. While the *Warm Glass* book presented me with multiple options for working with glass, the focus was more on interesting ways to create art with glass. Angela Thwaites book was much more in depth on the lost wax casting method and prepared me with a great deal of knowledge going into the Penland Workshop. Having this familiarity with the medium and understanding the process was critical to having a more successful workshop experience. Considering most of my knowledge of working with kiln casting glass was gained during the Penland workshop, the bulk of the processes will be discussed in the methodology section of this thesis.

Historical Reference:

Current designs can take cues from historic precedent, as seen in some works by Philippe Starck. Further precedent research delved into the historical context with the book *The Bulfinch Anatomy of Antique China and Silver – An Illustrated Guide to Tableware, Identifying Period, Detail, and Origin*, by Tim Forrest and Consulting Editor Paul Atterbury. This book is an exceptional source for tracing the evolution of eating and the tableware that accompanied the activity through various time periods as well as locations, beginning with a brief history of eating starting in the 16th century and progressing through the 17th, 18th, 19th, and 20th centuries.

Pewter and silver were the most common tableware at the table early on, with silver being for the wealthy. By the 17th century pewter was seen as a high maintenance material, since knives and forks would easily carve into the soft metal, increasing the popularity of slipware and delft as good alternatives. Exploration in the Far East and American colonies expanded the world of food. “Perhaps, the most important new feature was the significant role played by tea, chocolate and coffee in social life – this certainly spawned a new series of vessels for their preparation and consumption.” (Forest, 8). “The fork was a product of the late 1600’s and this also shows in the evolution of the knife losing its sharp point and blade becoming wider.” (Forest,9).

Chinese export china would expand greatly during the 18th century, as it was more durable than what was made at home. During this time period dinner

was served in the early evening and food was served in large dishes and tureens, placed in the middle of the table so that guests could serve themselves. This type of service is known as “*table á la Française*” (Forest, 9). The service was divided into two main courses and desert followed, which was the most ornate and exuberant. Books on cooking with recipes were abundant and the often included table setting guides as well.

Lavish dining continued throughout the 19th century, although the mode of service changed. The new style, *table á la russe*, featured a sideboard where the food was kept, and servants that would serve each guest. The introduction of lunch and afternoon tea also were introduced. This was in part a necessity as dinner moved to a much later time, 8:30p.m. (Forest, 9). Another change we see during this time period is the increasing acceptability of going out to eat, which Forest alludes is only possible as a result of the newly introduced grand hotels.

The 20th century saw an increased amount of technology in almost every aspect of daily life. Lavish tables have scaled down and become more approachable to the common man, with both prepared food and mass-produced decorative tableware becoming readily available. The years following World War II saw a sharp decline in the use of servants in the home as well as a more informal attitude at the table (Forest, 9). Modern styles start to emerge, multi-cultural cookbooks are widely available, the food was of higher quality, and much more diverse in its offerings. Through all of the preceding evolution of dining practices, many remain today, including lunch as a meal and the use of forks.

However; dinnertime moves back to early evening for many, and the afternoon tea disappears.

Throughout all of these time periods people were making and creating tableware. Forest's text breaks down history by periods and styles as well as by geographic location. One table shows us that early colonial America's dining customs were running parallel to the Jacobean style in Ireland, Louis XIII style in France, the beginnings of Baroque in Northern Europe and the Qing Dynasty in China. This table is then repeated showing the same information about ceramic designers and manufacturers, as well as silver designers and manufacturers. This book is an incredible resource to see all of these ideas running simultaneously throughout the developed world. Each section of the book focuses on a singular tableware, such as a tea service, showcasing popular styles, how the styles evolved from previous ones, and why they evolved. The level of detail and information is very comprehensive and often correlates changes in tableware with changes in eating habits. Many of the drawings can be utilized in guiding the design process for new tableware.

Historic Preservation:

While working on this thesis, I also completed work on a post baccalaureate certificate in historic preservation. It should come as no great surprise that this influenced my research in emotionally durable products. Many principles that are at the core of historic preservation can be applied to aspects of emotional durability theory.

Scholar and deputy general counsel at the National Trust for Historic preservation Tom Mayes was the recipient of the Rome Prize in 2013 in part for his blog series on *Why Do Old Places Matter?* (Mayes, 2016). In his blog series, his research evaluated fourteen different concepts of place identity, several relating to theories in emotional durability. According to Mayes, old places foster community through their quirky personalities as well as the gathering places they offer. They offer a shared place where individuals connect through common experiences, where they can create a sense of place, and where they can create a dialogue with the environment. Mayes also speaks on how old places create a sense of continuity, that gives people a sense of orientation and creates an emotional bond between person and place. This sense of place attachment is stronger with historical sites since they embody tradition and a sense of the past. These ideas that Mayes discusses correlate directly to emotional durability theories discussed by Chapman. The dialogue that Mayes talks about is the narrative that Chapman discusses, and Mayes' place attachment is the object attachment we are seeking in emotionally durable products.

The 19th century architectural critic John Ruskin had a profound and long lasting influence on historic preservation theory and practice. In his book, *The Seven Lamps of Architecture*, Ruskin discusses The Lamps of Truth and Memory. The lamp of truth speaks on authenticity in materials. An example is that if you want a building to look like stone, build the structure of solid stone rather than covering a wooden structure with a thin veneer. The idea of a stone

structure gives the individual a sense of permanence and solidity that is not conveyed with the thin veneer. This authenticity in material creates an authentic and meaningful experience for the user. In his chapter on the lamp of memory Ruskin suggests the value of age and patina in buildings

For, indeed, the greatest glory of a building is not in its stones, or in its gold. Its glory is in its Age, and in that deep sense of voicefulness, of stern watching, of mysterious sympathy, nay, even of approval or condemnation, which we feel in walls that have long been washed by the passing waves of humanity. It is in their lasting witness against men, in their quiet contrast with the transitional character of all things, in the strength which, through the lapse of seasons and times, and the decline and birth of dynasties, and the changing face of the earth, and the limits of the sea, maintains its sculptured shapeliness for a time insuperable, connects forgotten and following ages with each other, and half constitutes the identity, as it concentrates the sympathy, of nations; it is in that golden stain of time, that we are to look for the real light, and color and preciousness of architecture; and it is not until a building has assumed this character, till it has been entrusted with the fame, and hallowed by the deeds of men, till its walls have been witnesses of suffering, and its pillars rise out of the shadows of death, that its existence more lasting as it is than that of the natural objects of the world around it, can be gifted with even so much as these possess of language and of life. (Ruskin, 177)

Here Ruskin is discussing the evolution of buildings and how they develop a patina over time. More importantly he is speaking of a dialogue that is created between human and building. This dialogue is the specific idea that Chapman discusses when he writes about creating empathy through a sustaining narrative.

In *The Past is a Foreign Place*, author David Lowenthal speaks to authenticity, patina, and ongoing use.

We must reckon with artifice no less than the truth of our heritage. Nothing ever made has been left untouched, nothing ever known remains immutable; yet these facts should not distress but emancipate us. It is far better to realize the past has always been altered than to pretend it has always been the same. Advocates of preservation who adjure us to save things unchanged fight a losing battle, since even to appreciate the past is to transform it. Every relic is a testament not only to its initiators but to its inheritors, not only to the spirit of the past but to the perspectives of the present. (Lowenthal, 412)

In this quote we see how the evolving dialogue that Chapman believes is integral to creating emotional durability is a key component to the success of historic preservation. The places we inhabit and the objects we fill them with are going to change as we use them, and this is a positive attribute. Embracing this change and celebrating the evolution creates a bond between the user, building, and object.

Jeremy Wells discusses how authenticity is a core premise of historic preservation in *the Forum Journal*. Wells speaks to authenticity in three dimensions: fabric-based, constructed, and phenomenological (or experiential). He makes the case that “the traditional, fabric-based definition of authenticity ignores a diverse range of subjective meanings that may, in fact, be immensely important to stakeholders.” (Wells, 36). Authenticity embraces an honesty between the user and object, averting the user from being disappointed by an object that is not what is touted to be. We also see a relation back to Chapman and his discussion on narrative and the story that we develop with an object over time through continued use.

Finally; in Christian Norberg-Schultz's book *Genius Loci, Towards a Phenomenology of Architecture*, he writes extensively about the phenomenon of place, the structure of place, and the spirit of place. He re-introduces the idea of place as an existential dimension rather than a mathematical concept and tells us that "man is an integral part of the environment, and that it can only lead to human alienation and environmental disruption if he forgets that (Schultz, 23)."

There are common themes that connect all of these historic preservation theories together. Authenticity in materials, creating a sense of place, and embracing the development of a dialogue between user and building. These theories resonate with the theory of emotional durability in principle and practice. One difference being the scale of product design is more intimate than the scale of building design. This is the opportunity for the product designer to carefully consider each small detail to start a dialogue between user and artifact.

CHAPTER III

METHODOLOGY

The Heuristic Approach:

Research projects, whether quantitative or qualitative, necessarily begin with an inquiry or phenomenon. The heuristic method gives the qualitative researcher a guide and method in which to carry out research to generate credible results. Clark Moustakas describes heuristics as “a process of internal search through which one discovers the nature and meaning of experience and develops methods and procedures for further investigation and analysis (Moustakas, 9).” He elaborates, saying that the “heuristic processes incorporate creative self—processes and self—discoveries.” (Moustakas, 9) Like other research methods, heuristic research gives the researcher a system for investigating and framing their research.

In the book *Heuristic Research, Design, Methodology, and Applications* author Clark Moustakas breaks heuristic research down into six phases

1. Initial Engagement
2. Immersion

3. Incubation
4. Illumination
5. Explication
6. Creative Synthesis

The first phase of initial engagement is where the researcher identifies a question that he or she desires to explore. This question should be “a passionate concern that calls out to the researcher, one that holds important social meanings and personal, compelling implications (Moustakas, 27). Phase 2, immersion, is what I would call the blue skies phase, where anything and everything is possible, there are no limits. The researcher lives and breathes the question looking for all information that can be relative or connected in some manner. Moustakas states that “Primary concepts for facilitating the immersion process include spontaneous self-dialogue and self-searching, pursuing intuitive clues or hunches, and drawing from the mystery and sources of energy and knowledge within the tacit dimension.” (Moustakas, 28). The incubation phase follows immersion, and this phase is where the researcher is not actively engaging with the question. This is a time of retreat that I liken to a soup being better the day after you cook it. Allowing a soup to rest and come together gives us a better product. The same is true in this phase of research. After we have immersed ourselves in a subject we need to step back and let the knowledge sink in and let the mind process everything. Following this time of incubation is the illumination phase, or the

breakthrough phase. “Illumination opens the door to a new awareness, a modification of an old understanding, a synthesis of fragmented knowledge, or an altogether new discovery of something that has been present for some time yet beyond immediate awareness.” (Moustakas, 30). During this phase of research all things start to make sense and the researcher is applying a gained and understood knowledge to their question. Phase five is the Explication phase, where corrections and refinements are made. “The researcher brings together discoveries of meaning and organizes them into a comprehensive depiction of the essences of the experience... and is now ready to put them together into a whole experience (Moustakas, 31).” This is the phase where the researcher does a self-check. Everything has come together and can be united into a cohesive package. The final phase of heuristic research is creative synthesis. Here the researcher has a mastery of the material and knowledge surrounding the question. Sometimes this is expressed as a narrative and can also be expressed in other creative forms. The process can be visualized in the diagram presented in Figure 13.

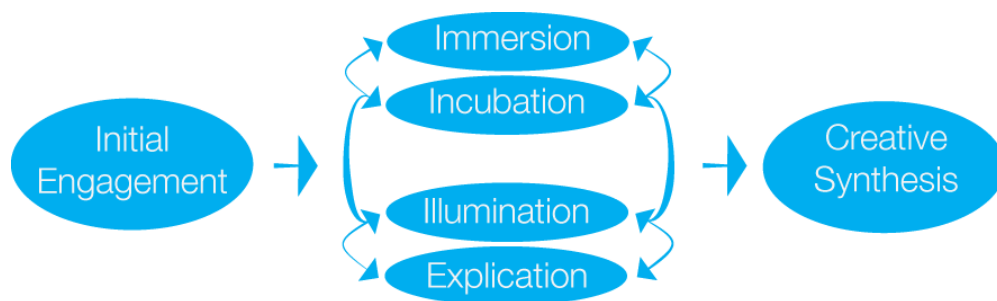

Figure 13. Heuristic Method Diagram

This methodological approach gives the researcher a valid way to arrive at conclusions for their question. This method is qualitative in nature does not rely on statistical analysis to show validity. Moustakas attests:

The question of validity is one of meaning: Does the ultimate depiction of the experience derived from one's own rigorous, exhaustive self-searching and from the explications of others present comprehensively, vividly, and accurately the meanings and essences of the experience? (Moustakas, 32)

He describes research as an experience, as is the process of designing and making. Learning new methods of fabrication, learning how to work with new materials, learning how humans interact with and become attached to objects were just some of the questions that I wanted to explore. The application of this methodology is seen in the process of making. Each new material possesses its own set of nuances that influence design. The design of a product may not be successfully created in every material. There will be a multitude of failures that will inform new iterations and lead to successes.

The research of this thesis is broken down into 4 divisions, each corresponding with a particular studio class. These divisions incorporate the six phases of the heuristic method, not all methodology phases will manifest in all research divisions. Division one takes us through the first four phases, ending with the illumination that I must produce my product line to have control over the quality of the designs. In division II I am learning new materials and how to create objects by hand. Working with these materials informs my process and

leads me to make small changes in designs to help them become more successful. This second division had the most failures and even more successes. We experience the explication phase during this division through constant critique, by peers, faculty, and myself. Work is constantly being produced, questioned, and evaluated. There is also an important illumination that the touch of the hand and the surface are critical to creating emotional durability in a product. Division III was an immersion in working with glass. Even though the time frame for this division was very compressed, illuminations were made that resulted in better casting techniques. After working through the previous divisions, and letting my new knowledge incubate; I was able to integrate their components and core themes into a creative synthesis during Division IV.

Division 1:

The first division of research began with the question: If your house was on fire, and you could only take five items from the kitchen, what would they be? This question was asked to identify objects to which I already had a strong emotional connection. Having a relationship with these items would help me understand what made them emotionally durable to me and help me in designing new objects that could also be emotionally durable. The items chosen were a pepper mill, a pair of drinking glasses, a bowl, a serving item, and an eating utensil. I proposed to design each of these items and have another individual produce them for me in five different materials. The rationale for this process

was that I could focus on developing and refining products rather than spending the majority of my time learning how to work with new materials. Each material possesses its own set of attributes and nuances that must be learned over time with experience. Materials chosen for this phase were glass, wood, porcelain, and metal; a broad spectrum that can showcase many different qualities for each object. The goal of having the group of objects made in five materials is to determine if a particular material contributes to an objects emotional durability. This area of research is in line with Jonathan Chapman's criteria on surface.

The design process started with comparing Philippe Starck's Juicy Salif juicer, referenced in the literature review of this thesis, to a more standard kitchen juicer. Two design attributes stood out. First, Juicy Salif is elevated, so that a container can be placed underneath for the juice to collect in. Second, the actual juicing area features rounded ribs to extract the juice. When looking at the historical juicer, there were no legs, however, there was a pour spout. In contrast, the juice extracting ribs on this juicer were fluted, with sharp edges to shred the pulp of the fruit to extract more juice. This gave me an initial concept to explore: the idea of a reeded surface versus the idea of a fluted surface. When thinking about these two types of surfaces the fluted surface suggests that it will show stronger contrast between areas of high touch and areas of low touch. The reeded surface implies a more gradual development of patina. The development of patina is central to the surface argument presented by Chapman, which led

me to choose the fluted surface design. This concept drove the surface design of each piece I created.

The design of a footed bowl began the design process. A tazza was used as a historical reference. Typically a tazza is an elevated shallow bowl for ceremonial purpose. Often they have highly articulated designs covering the surface that celebrate a victory. In the early 20th century they were marketed to individuals on a European tour to take home as a souvenir. The celebratory and ceremonial nature of this piece fits with my strong desire to share and celebrate food. The shallow tazza bowl shape was included in the design of the bowl and a short foot elevates the piece to show hierarchy on a table. The shallow design lets the bowl act as a plate, bowl, platter, or a serving dish.

The design process was carried out utilizing Rhinoceros 5.0, which is a digital, 3-D, NURBS modeling system. What are NURBS?

NURBS, Non-Uniform Rational B-Splines, are mathematical representations of 3-D geometry that can accurately describe any shape from a simple 2-D line, circle, arc, or curve to the most complex 3-D organic free-form surface or solid. Because of their flexibility and accuracy, NURBS models can be used in any process from illustration and animation to manufacturing (rhino3d.com/nurbs).

The initial shape of the bowl was created as a line drawing. The example shows the final version used in the creation of the bowl (Figure 13).

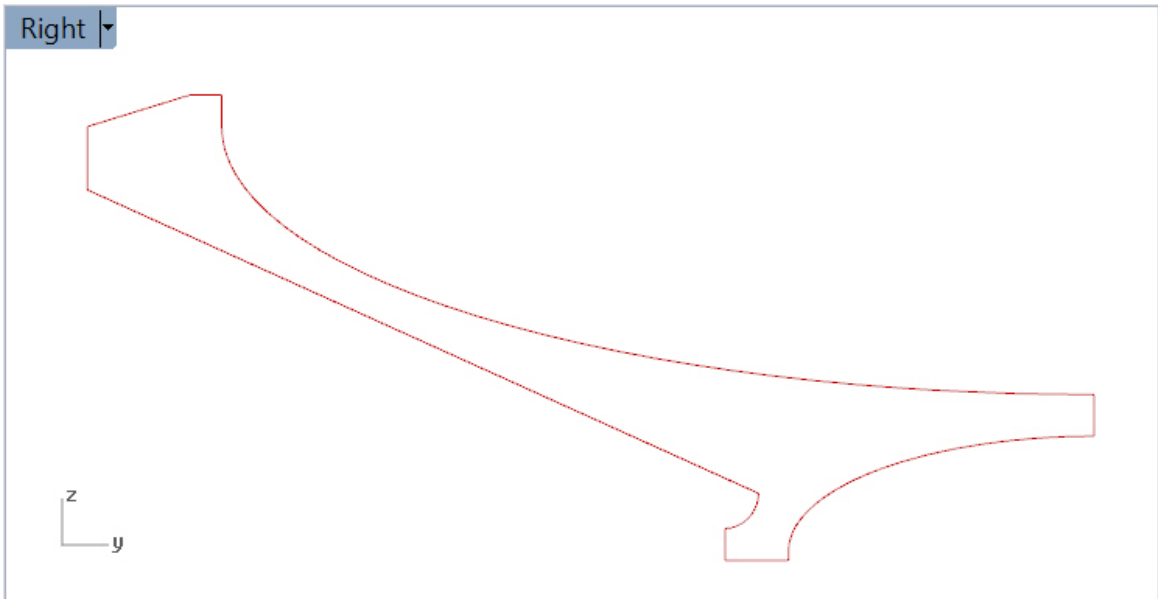

Figure 14. Bowl Design Process

Once this line was created I used the revolve command to create a 360 degree sweep of the line to create a solid (Figure 14). This process was carried out multiple times until the resulting shape felt appropriate. This solid would then be fluted to incorporate the originating concept.

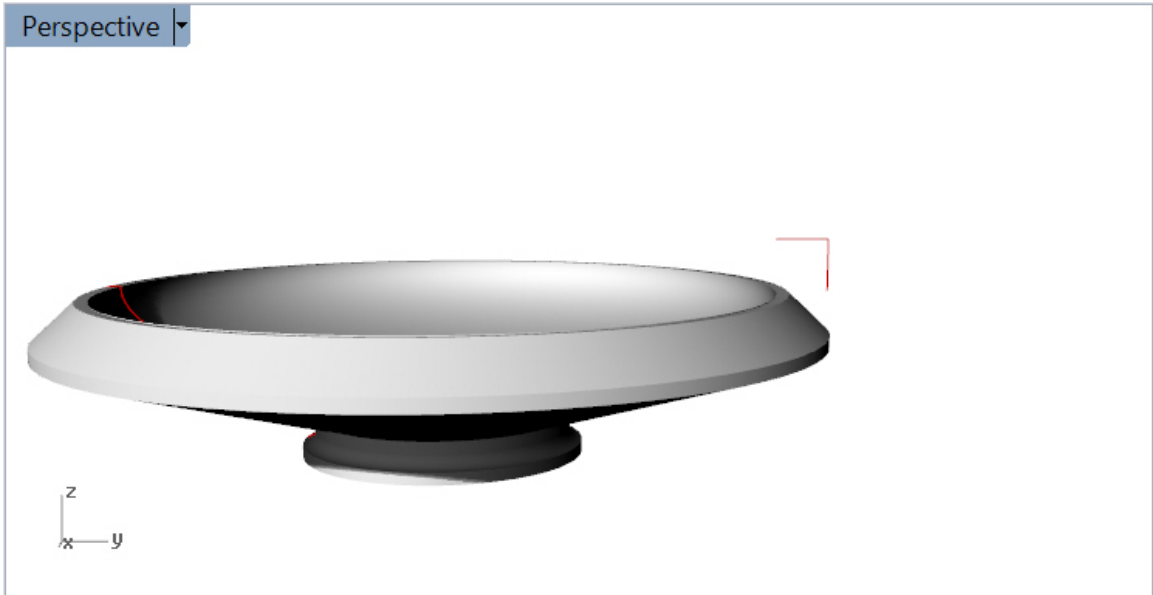

Figure 15. Bowl Design Process

A line was created that followed the profile of the outside of the bowl. A closed rounded tube was extruded around this line, figure 15. This tube was then radially arrayed around the bowl. Using the Boolean function, I used these tubes to make cut outs on the exterior surface of the bowl. Each of these cut outs created a singular flute on the surface. The geometry around the foot of the bowl was incredibly complex, which did not allow the Boolean function to work properly. Increasing the scale of the bowl by 200 percent eased the geometry and allowed the Boolean function to work. 32 flutes were created on the surface. This number allowed an even spacing around the base of the bowl (Figure 15). After the design phase was complete the product had to be turned into a mesh model to be 3D printed. This was accomplished by using the mesh command and the file was saved in a stereo-lithography or .stl format. This bowl was

initially 3-D printed in gypsum powder using a Z-corp 450 3-D printer (Figure 16). This initial prototype had to be scaled down to fit within the printer's bounding box, resulting in a smaller than designed prototype. Even at a reduced scale the object could be evaluated in terms of proportion, design, and overall successfulness. A second print was ordered and would be produced in porcelain by the Shapeways Company.

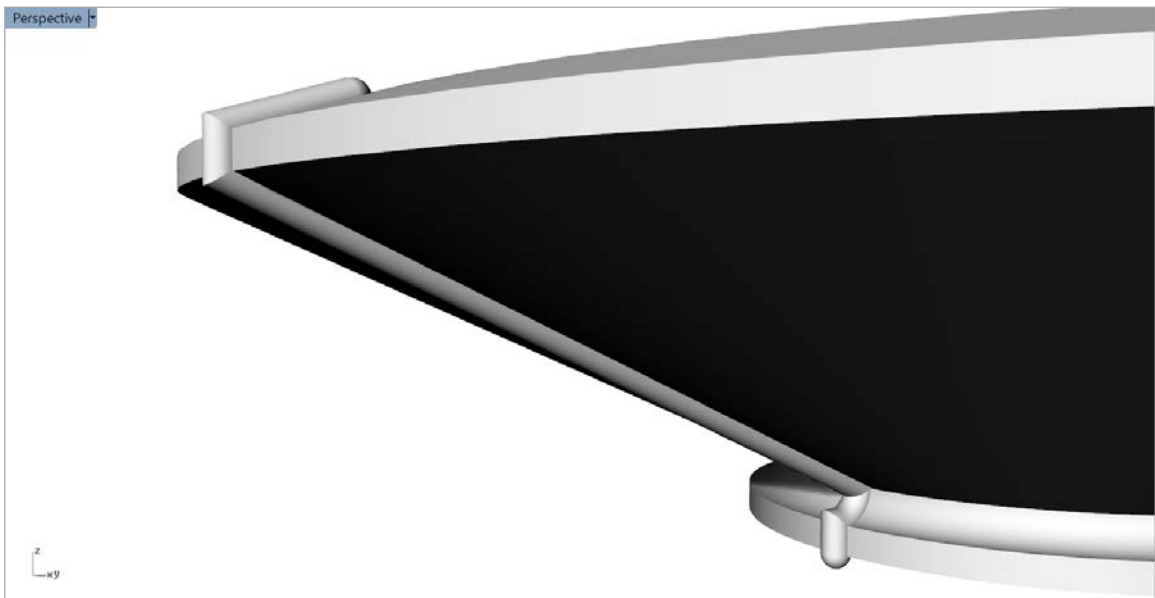

Figure 16. Bowl Design Process

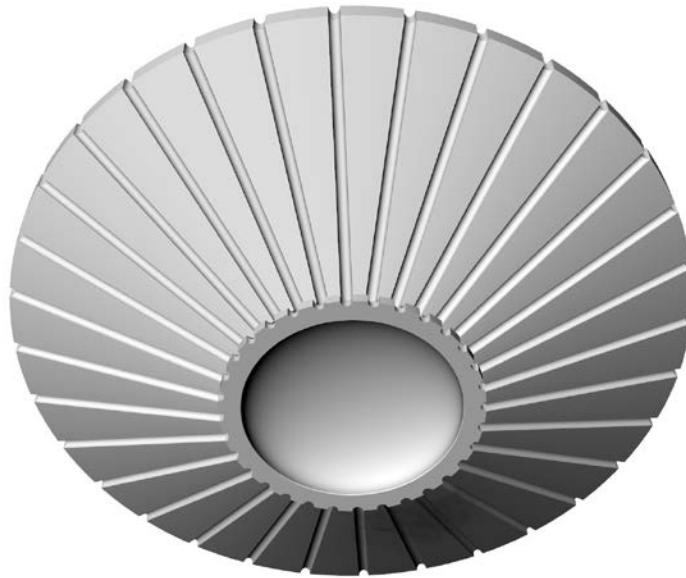

Figure 17. Bowl Design Process

The vessel was also created digitally using Rhinoceros 5.0. The historical reference for this piece was the coliseum in Rome, particularly the elliptical shape. The design is intended to be able to be used as a drinking vessel for hot or cold beverages, a small vase, or a tea light candleholder. The design starts with the creation of a profile line to be revolved to create a solid, similar to the bowl process.

However, the elliptical shape does not allow for a simple revolve command to be completed.

Perspective

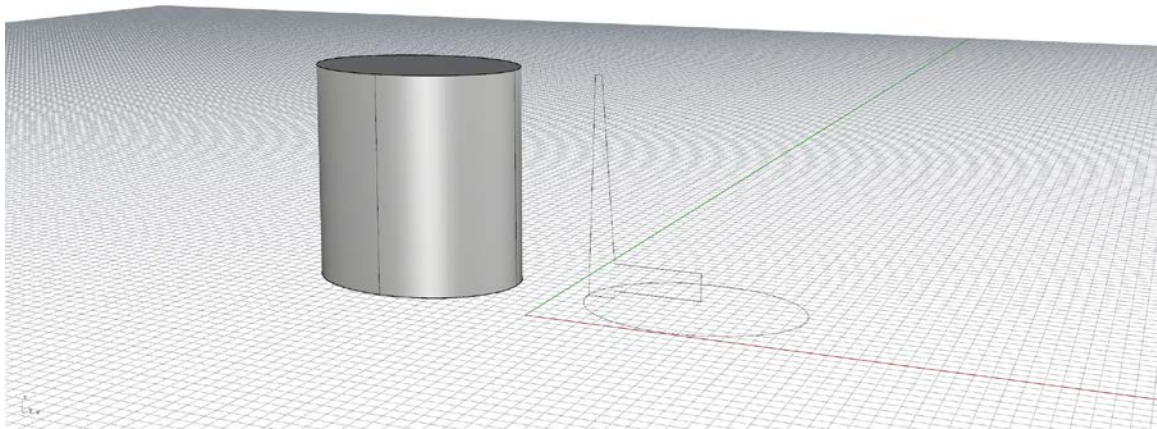

Figure 18. Vessel Design Process

A rail revolve was necessary to extrude the profile along an ellipse line to create the solid elliptical shape of the vessel (Figure 17). Flutes were added to this vessel in the same manner as in the bowl. However, this time I tried aligning them so that each flute touched the one next to it, leaving no space between each flute. I uploaded this first iteration to the Shapeways site for them to evaluate the build-ability of the object (Figure 18). The thin protruding edges of each flute were identified as a problem, and were not printable.

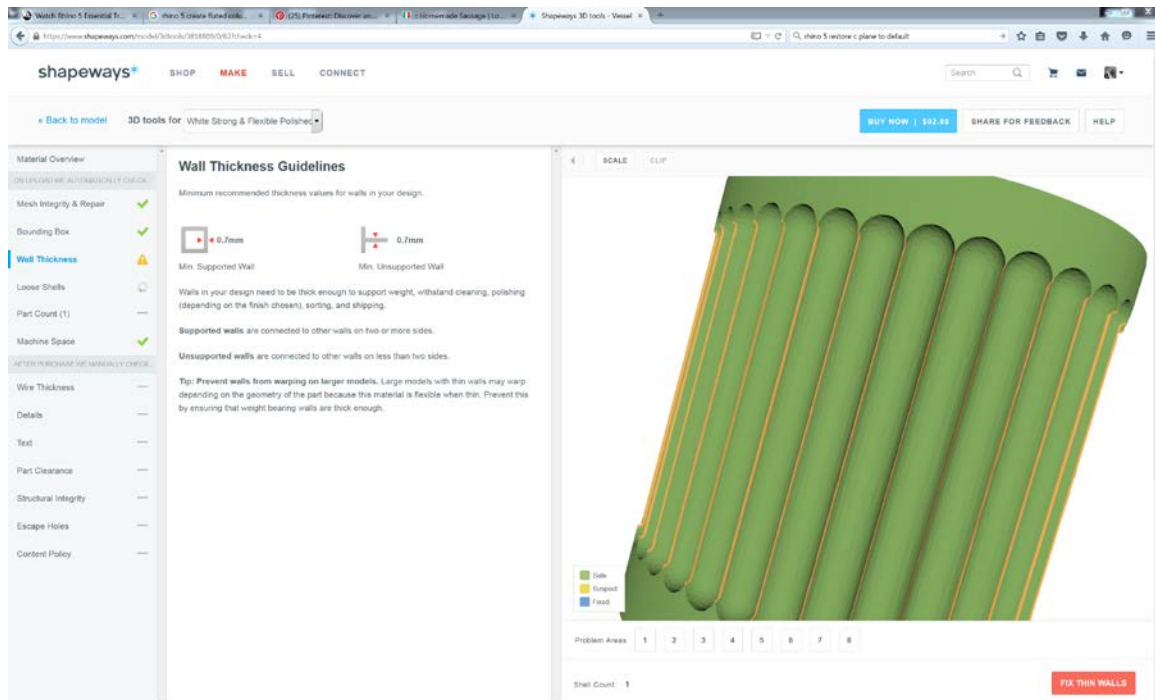

Figure 19. Vessel Design Process

A second iteration was created. The minimum wall thickness allowed by Shapeways was inserted between each flute, creating a printable file. Other precedents showed thick, heavy bottoms on drinking glasses, and small unglazed feet on coffee cups. An iteration was created that combined both of these elements. A thick rim that elevated the base from a surface, yet was still heavy like the precedent. The first prototype of the vessel was created in Poly Lactic Acid (PLA) on a Maker Bot Replicator. The prototype felt big in the hand, almost too big, and the thick rim on the base was perceived as being clunky and unrefined (Figure 19).

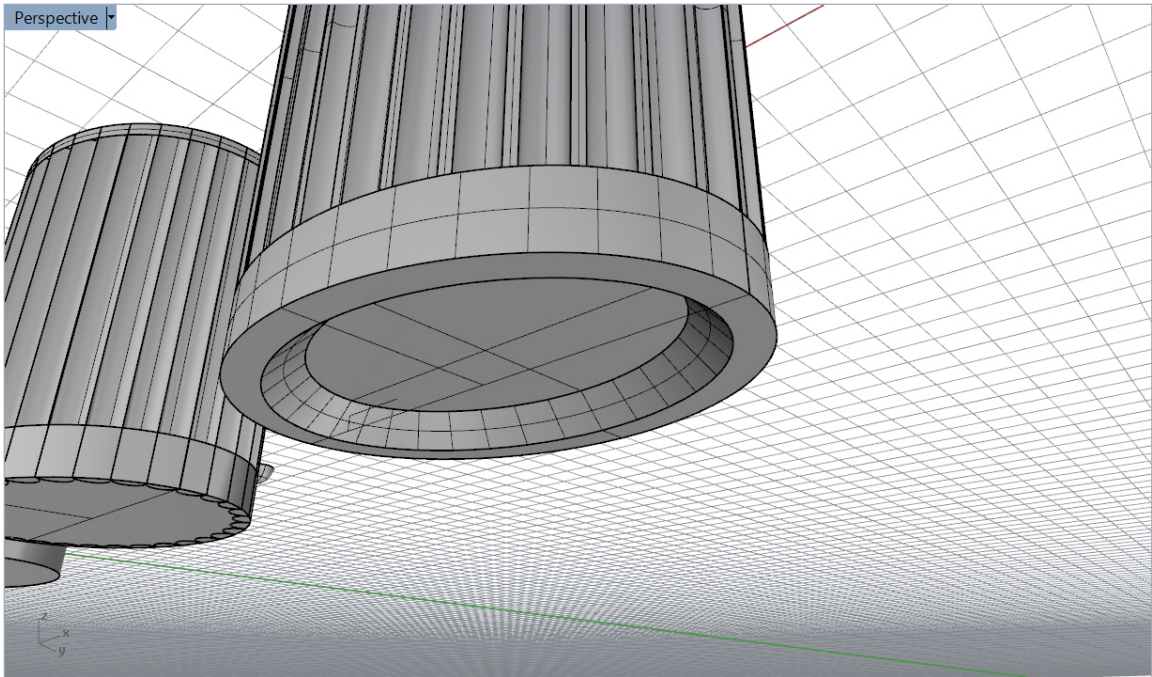

Figure 20. Vessel Design Process

A third iteration reduces the scale of the vessel and features a rounded bottom on both the inside and outside of the vessel (Figure 20). The elevating rim is still present and has been thinned and curved to create a more elegant form. This iteration was also 3D printed in PLA and conveyed the impression of being more refined, elegant, and felt better in the hand. After the success of this prototype the file was submitted to Shapeways to be 3D printed in porcelain.

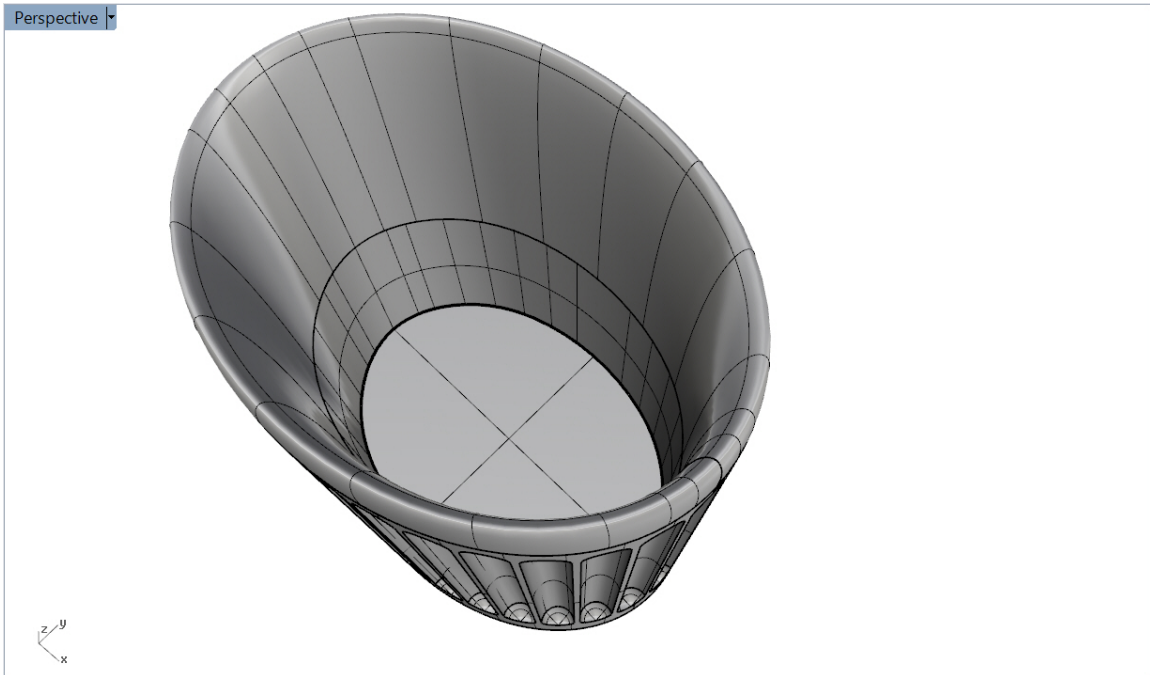

Figure 21. Vessel Design Process

A peppermill was the third product to be designed. The historic reference that this piece is based on is the Venus of Willendorf, a sculpture representing the female form dating to between 28,000 and 25,000 BCE. The form features a round head-like piece attached to a squatty, wide hipped figure. This reference was used to suggest familiarity and encourage individuals to use the product. I looked at other peppermills for precedent, as well as peppermill kits to influence the overall scale of the piece. Working in Rhinoceros 5.0 the form began to emerge.

Perspective ▾

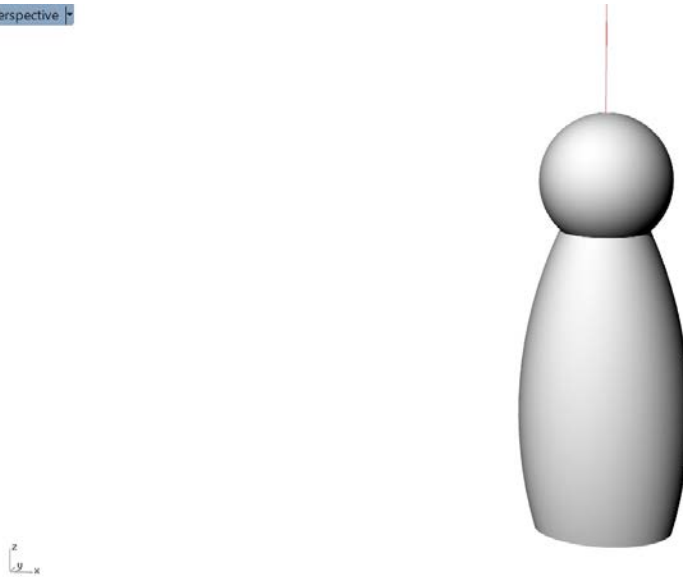

Figure 22. Peppermill Design Process

An elliptical base was combined with a round top to combine the design language seen in the previously created bowl and vessel. The round top was also necessary for the piece to be functional. The overall curve of the exterior shell was derived as part of the iterative design process (Figure 21). Once the overall mass was conceived the flutes were added. 3D printing industry wall thickness minimums dictated the spacing at the top. Connections at the base were equally spaced around the form. The morphing of the form from top to bottom and side to side meant that the flutes could not be arrayed around the form. The top and bottom connection points were used as a guide to create lines on the surface of the model. These individual lines acted as a guide for capped tubes to be extruded around (Figure 22).

Perspective



Figure 23. Peppermill Design Process

The flutes were then individually created using the boolean function. The top piece of the peppermill is a sphere, meant to mimic the head of the Venus figure. Flutes on this form are treated differently than on the body of the peppermill. It was imperative for these flutes of both pieces to match. However; this created a very rough textured termination point at the top. This is also the space where the compression screw would be. Meaning that when operating the peppermill the compression fitting would be grinding against an uneven surface (Figure 23).

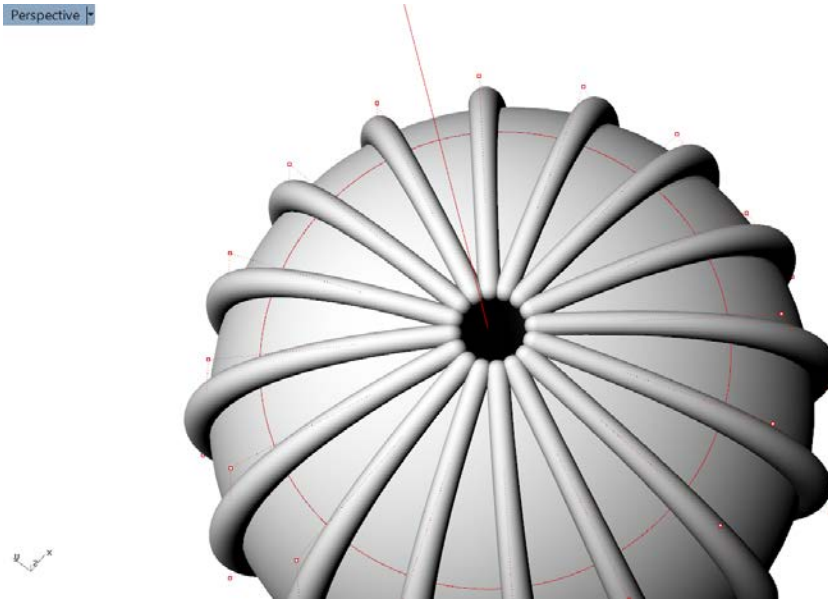

Figure 24. Peppermill Design Process

A second iteration tapered the flutes from the base to the top, resulting in a smooth surface at the top of the ball as well as a more elegant form (Figure 24). With the exterior form created, the next task was to make it a functional peppermill. Carbon steel peppermill grinder parts were ordered to coincide with the overall height of the form. The interior specified from the parts kit was a single cylinder from top to bottom. This would create a large void between the exterior and interior walls of the peppermill body I designed.

Perspective



Figure 25. Peppermill Design Process

Perspective

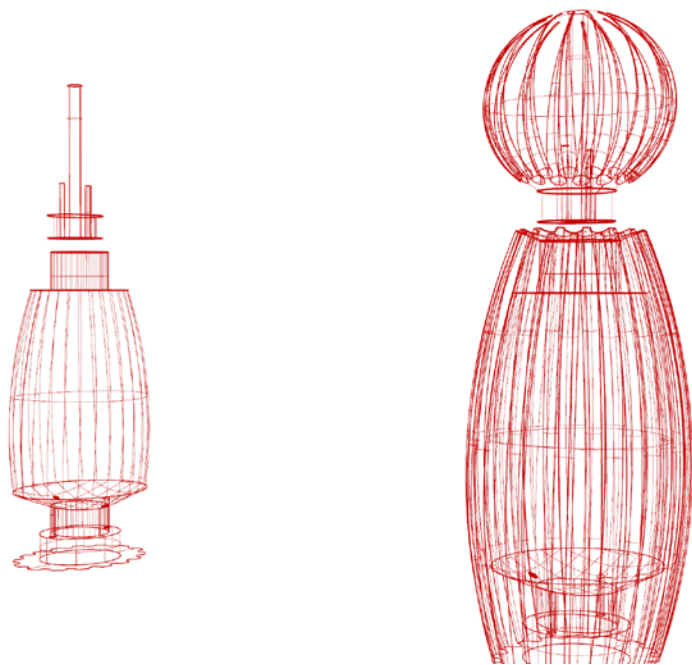

Figure 26. Peppermill Design Process

In reality the only dimension that was necessary was at the base where the mill would need to attach to the peppermill body. This left the majority of the body available to house peppercorns. I created offsets from the initial peppermill body to allow the interior to mirror the exterior. A sloping base was added to the inside to funnel pepper to the pepper grinder (Figure 25). This would allow a substantial quantity pepper to be stored inside the finished mill and necessitate fewer refills adding to the functionality and overall emotional durability (Figure 26).

Image 26



Image 27

Figure 27. Peppermill Design

The fourth product to be designed was a teapot. A historical precedent study for this piece looked at antique sterling silver teapots, specifically from Gorham Manufacturing. This teapot is oval in shape and is smaller at the foot and wider at the top rim. I was drawn to this piece for its use of gadrooning around the base. Gadrooning is similar to reeding, yet differs in the surface usually tapers or twists. The handle of this teapot was also intriguing with its Grecian motif and thumb button to aid in control of the kettle during pouring.

The design started out by creating an elliptical form that I cut in half to create the body of the teapot. This surface was fluted in the same manner as the previous products. A tea spout was added and the design didn't feel right to me (Figure 27).

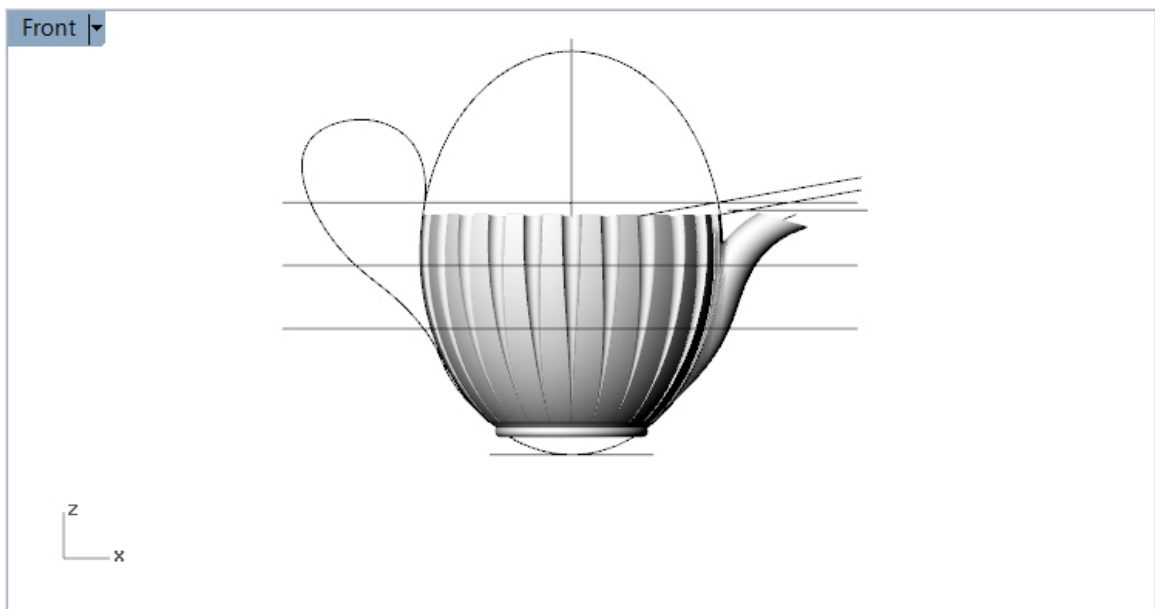

Figure 28. Teapot Design Process

I chose to do additional precedent research which led me to a Wedgwood porcelain teapot in the Anthemion pattern. This teapot shows a linear flared body shape, the same Grecian inspired handle, and a long elegant spout. Changing the body of the teapot I was designing allowed the design to appear much more appropriate and more connected to the previous objects which had already been designed (Figure 28). The body was fluted, an elliptical finial was added to the top, and a Grecian inspired handle was added.

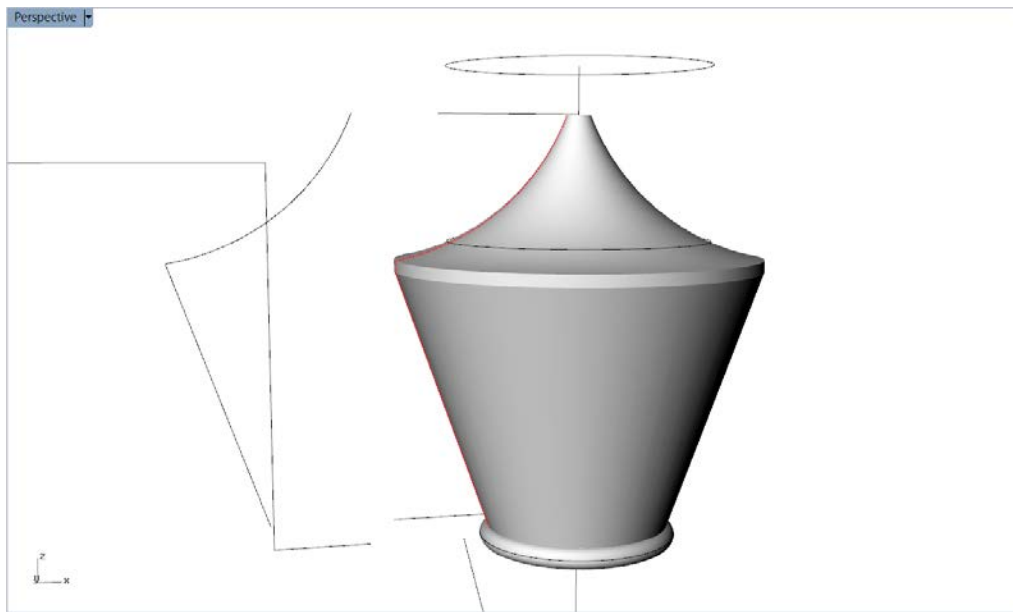

Figure 29. Teapot Design Process

Thumbnail 2



L

Figure 30. Teapot Design Process

The spout would prove to be the most difficult part to design (Figure 29). The base is elliptical in form, which then curves up and out in an s shape while also tapering. Numerous iterations were constructed and refined before one was ultimately deemed appropriate (Figure 30). Achieving proper proportions and balance were the most difficult aspect of this design.

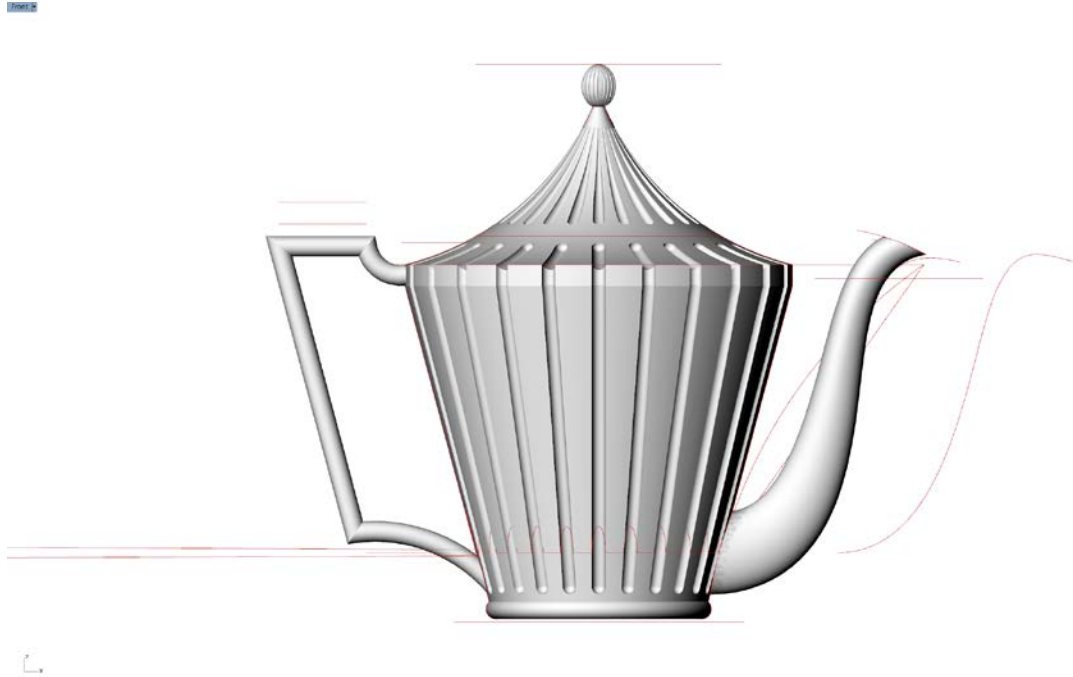

Figure 31. Teapot Design Process

Production Process:

With the initial design phase completed production began. The goal was to have artisans produce each of the designed objects in porcelain, glass, brass, and wood. The Shapeways Company could 3D print the items in porcelain. All of the designs were uploaded for production. Pricing was approachable ranging from \$100 - \$150 per print. The initial order was for the vessel, bowl, and peppermill to be produced. Once these arrived I evaluated the quality and move forward. While these were being produced I worked on identifying other artisans.

A glass artisan, Hugh McKay with Glass Artisans, was extraordinarily helpful in discussing the production of my products in glass. He could take my computer file and transform it into an exact production in glass. The one issue with having him produce the products was price. Each piece would have a \$450 mold fee and casting fee of \$400, making the 1st prototype \$850. If I could order 10+ units of each product the cost per piece would go down to \$225 each. This was quite simply not an affordable option for me to explore.

An alternative to this would be to 3D print the pieces in hard clear plastic. This would give the appearance of glass at a reduced cost, approximately \$45 per item. I contracted with Meadors Inc. out of Charleston S.C. who had a 3D printer that could print in this material, photopolymer resin. The vessel came out perfect with incredible detail. However, the crystal clear element was missing in the actual prototype (Figure 31). Incidentally, the peppermill could not be printed. Multiple attempts were made and the printer would stall part of the way into the print. Meadors' technicians couldn't figure out the problem and Formlabs, the manufacturer of the machine, could not figure it out either (Figure 32). This left me at an impasse with this production method, necessitating the exploration of alternative production methods.



Figure 32. 3D Printed Prototype

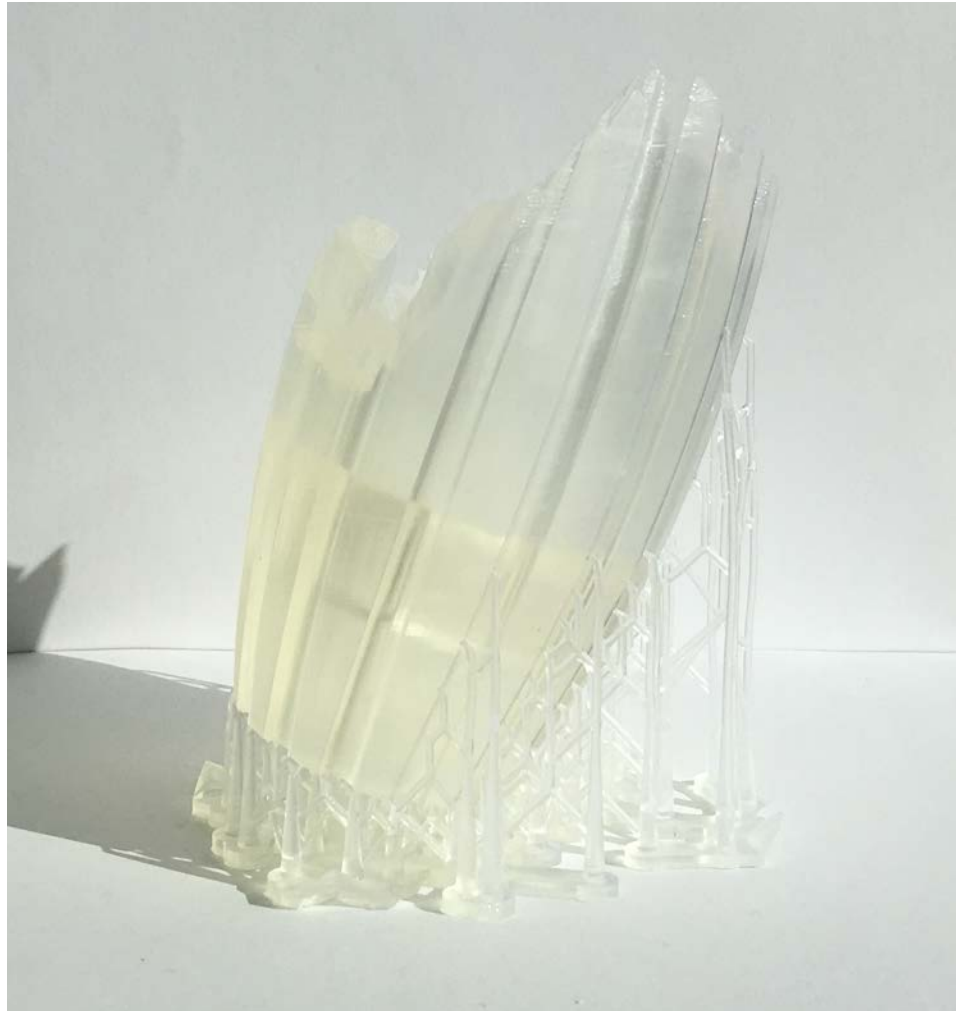

Figure 33. 3D Printed Prototype

Multiple metal machine shops were identified to produce the products in soft brass. I only approached machine shops that had a 5 axis cnc mill, which would be necessary to produce the complex surface designs. I worked with Luke Hendrix of Xometry to get quotes. The web interface showed an initial quote of approximately \$250 for each product, which was expensive yet considerably more approachable than the quote I had received in glass. Luke contacted me to

let me know that the items were not a good fit for them to be able to produce the products in a cost effective manner. Primarily, they did not have any “fixturing” to hold the parts for production. Three additional metal milling operations would not quote me, as they did not do one offs, only production runs. This proved to be a stopping point for this material.

Wood was the last material to have products made in. I approached 3 firms to have them produce the products for me, Mahoosuc Woodworks, Jae Gee Wood, and JMP Wood Products. Each of these companies have websites touting their ability to create anything in wood, either by hand or by 5 axis CNC mill. Multiple requests for quotes were ignored. I finally was able to get JMP to respond that they only would use their CNC mill to produce stair balusters, even though kitchen products were listed as something they could fabricate. This was very discouraging, and also a stopping point for this material. By this time I had received the 1st porcelain prototypes from Shapeways. These too were not encouraging. The glaze was exceptionally thick which obscured most of the detail in the pieces. The peppermill was not functional. Shapeways does not let you specify areas to not to be glazed, so the top would not fit in the base. Additionally, the overall quality control was not of a high enough standard. Rims were inconsistent and glaze was missing in areas (Figure 33). However; the strongest argument against the porcelain pieces was that they did not embody any of the desirable properties of porcelain. For me porcelain is a fine material, it is exceptionally dense, which makes it both durable while appearing fragile.

Thinner wall thicknesses should be translucent adding to the allure of the material. These pieces were no better than a cheap imported design created from an inferior material.



Figure 34. 3D Printed Prototype

The failures that surrounded having others manufacture the products I designed were a game changer. 3D printed porcelain embodied none of the admirable qualities of the material. Glass was cost prohibitive. Metal and wood both seemed to be too complicated for digital production, even though the machinery exists that can fabricate my designs. In hindsight, creating five products in four materials was too much to feasibly accomplish in one semester's time. From these observations, I concluded that I must manufacture each of the products myself rather than contract with an outside source. This gave me

complete control over the quality of the products as well as give me a deeper understanding of the materials I am designing for. A limitation of this production method is that I must learn how to work with each material.

Division Ib:

This division ran parallel with division I as an advanced computer aided design studio that sought to combine the digital process with the handmade process. Lighting is area that I am extremely interested in as it can have a dramatic impact on the built environment and how we as humans experience a space emotionally. While researching emotional durability in lighting design could be a thesis in itself; I chose to do an ancillary study to coincide with my research on tableware. I chose to work with the typology of a chandelier. This type of luminaire is often seen above tables where we eat and can be instrumental in strengthening the dining ritual.

The design concept of this piece combines two 17th century precedents with the concept of emotional durability. An Italian wire chandelier and a Portuguese four-poster bed with turned posts combine to create a new yet familiar form. Consistently, this type of chandelier features a carved wood central body, thin wire arms, carved wooden drop details, and a painted finish. The Portuguese bedposts show a wide variation in turning. Some areas are tight, staying close to the post center, and others make dramatic statements as they radiate further from the center. The goal with this piece is to exaggerate the form of the bedpost and to create a central body that is turned in wood (Figure

34). Other elements in the chandelier, such as bobeches and drop ornaments, are derived from the bowl designed in Phase I, and are 3d printed (Figure 35). The chandelier arms are to be fabricated of hollow brass rod that is bent using a jig created from the 3d file. During the design process I measured antique chandeliers that were present in my home as well as looked at commercially available new fixtures. Scale and proportion were critical in the development of this piece. Like the other objects I designed, lines were revolved and manipulated to create the overall form, which I then adjusted and tweaked until the design felt appropriate. The decorative aspects that were being 3d printed were further manipulated to include flutes which are seen in the other designs I created. Producing the chandelier took a great deal of research to determine how all the parts fit together. Dis-assembling and re-assembling one at home showed me that there is a central threaded rod that runs the height of the chandelier for everything to attach to. This would serve as a base for this chandelier too. The central core was to be constructed of turned wood. I utilized 4/4 poplar which is hard and easy to carve. Circular discs were cut out of a board that matched the diameters of the discs created in the 3D model. Each of these blanks were carved on a lathe to create a thin disc.

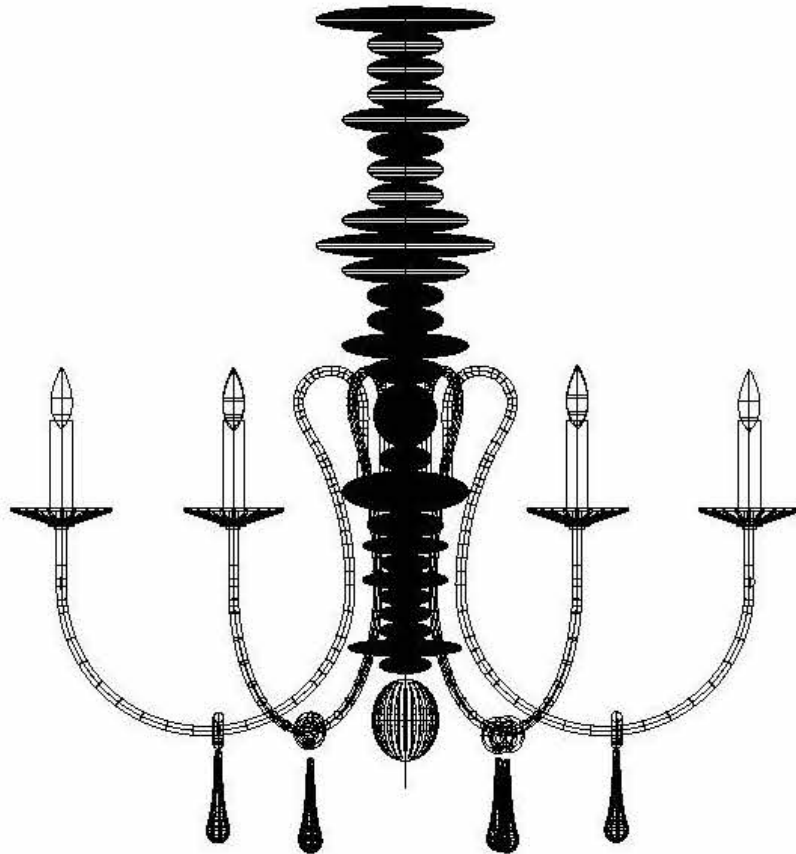

Figure 35. Chandelier Line Drawing

One section was carved more like a bowl to serve as a place for the arms to connect to the body and the electrical components to be housed. A thin metal disc was drilled to accept the threaded rod in the center and the arms equally

spaced around the edges. A full-scale elevation of one chandelier arm was printed and attached to a piece of plywood.



Figure 36. 3D Printed Chandelier Parts

Screws were screwed into the plywood, following the arm shape, to create a jig to bend the arms with. Three-foot sections of soft hollow brass tubing were manually threaded at each end to facilitate them attaching to the body and for the lamps to attach to each arm. The rods were then bent using the jig to create the arms (Figure 36).



Figure 37. Chandelier Process

To assemble the chandelier, the arms and central rod were first threaded with electric wire. The arms were then bolted to the drilled metal disc, and the threaded rod bolted through the center of the disc. Next the wooden discs were stacked on the threaded rod and secured with a threaded ring at both the top and the bottom of the rod. The 3D printed rings were then threaded onto the arms and the bobeches bolted to the ends of the arms. Candelabra Lamp sockets were attached on top of the bobeches. At this point the chandelier was assembled and showed all the different materials: brass, wood, and 3D printed gypsum. In keeping with the Italian chandelier precedent this piece was painted white (Figure 37). While this unified all the pieces into one cohesive piece, the piece seemed stark. I experimented with layering different paints and waxes to create a patina that was reminiscent of the precedent piece. While I typically would shun such behavior, I thought it was important to explore this technique as part of the creative process. Hopefully, this would allow a newly created piece to speak a language and fit in with an interior full of antiques. Upon completing this patina layer the chandelier came to life, details were more visible, and the entire piece fit comfortable in the imagined interior (Figure 38).

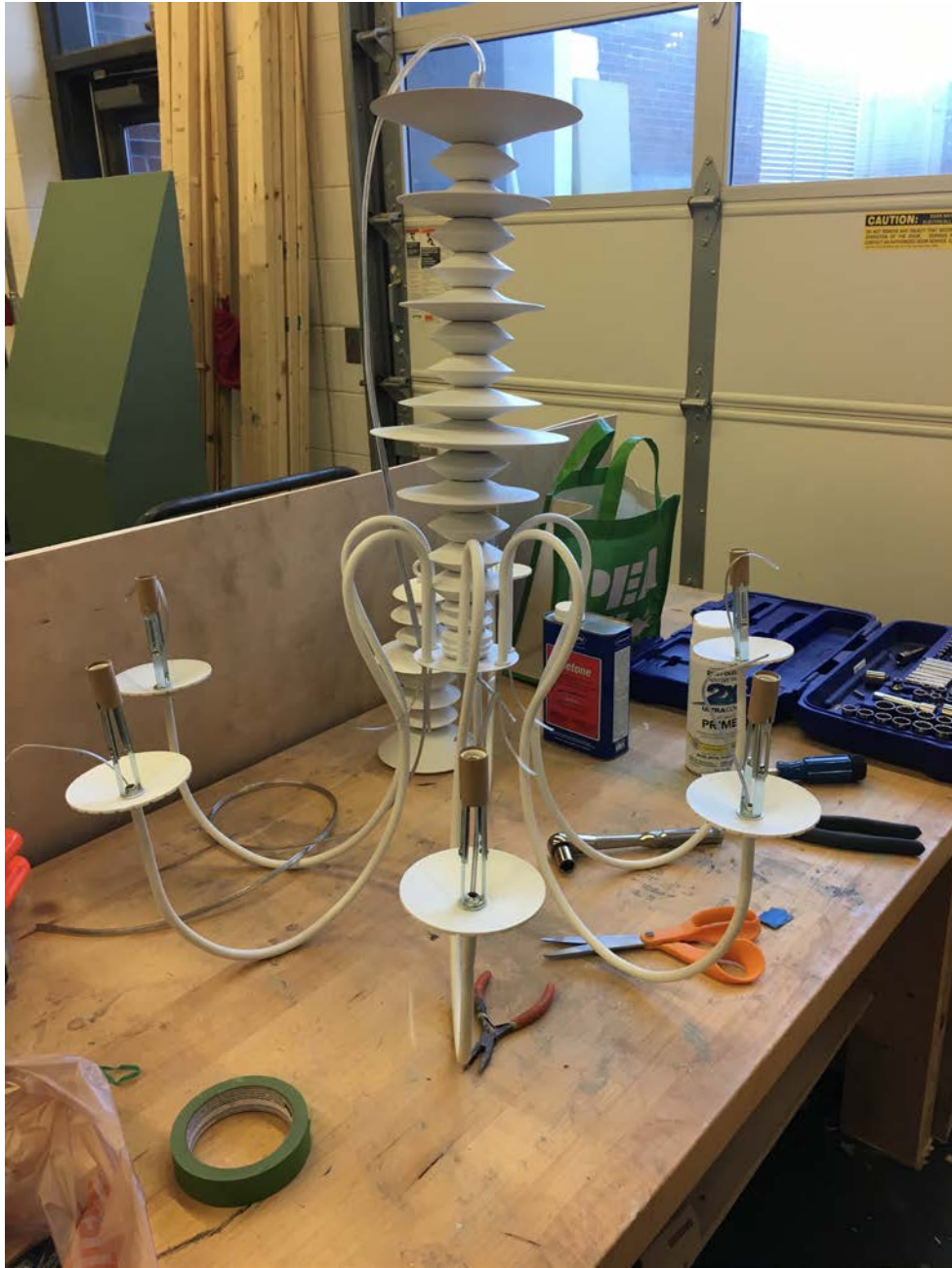

Figure 38. Chandelier Process



Figure 39. Chandelier Patina

In this studio a concept that presented itself during Division II was strengthened. The touch of the artisan hand is crucial in creating products that aim to be emotionally durable.

Division II:

This division begins with the intent to slip cast the products that I had created and 3D printed. Initially working with earthenware and then progressing to working with porcelain after I had an understanding of what I was doing. During this process I worked with Nikki Blair in the art department for guidance

and general knowledge on the process. Slip casting is a process where plaster molds are created from a positive, in this case my 3D printed products. When the molds are dry, clay slip, which is thin pourable clay, is poured into the molds. The plaster wicks moisture from the clay creating a clay shell around the interior of the mold. The excess slip is poured off and recaptured and can be used again. The wall thickness can be varied by allowing the slip to sit for longer periods of time in the mold. This is also dependent on how dry the mold is, the humidity in the air, as well as the ambient temperature. When I was making plaster molds, the complex nature of the fluted surfaces would necessitate the creation of multi piece molds. This was necessary to prevent undercuts that would trap the object in the mold and not let it release. Creating multi piece molds is extremely complicated, especially for a beginner. To simplify the process the flutes were filled in with clay during the mold making process. This simplified the molds into a two-piece system, which was approachable for me as a beginner. This would enable me to produce replicas of the 3D printed products. After getting the hang of slip casting, I produced several successful casts (Figure 39). At this point I began to focus on how to introduce the flutes back in to the surfaces. Further precedent research led me to ceramic artist Michael Sherrill who is world renown for his work. Carving surfaces are at the core of his art. He has developed a line of ceramics tools, Mud Tools. One of his tools is specifically for carving flutes in clay, the drag tool. Utilizing this tool I developed a method of carving the surface of the clay vessels I had created

(Figure 40). While this technique did not re-create the original flutes, it did create a textured surface. During a mid-term presentation and critique the surface was described as a triumph, and all those involved thought this surface is what brought emotional durability to the design.



Figure 40. Slip Cast Vessel



Figure 41. Carved Porcelain Vessel

This method of carving was applied to the other objects I had created with equal success. Clear glazes were applied to the products to celebrate the carving and not detract from the surface created (Figure 41). During this process I learned that the touch of the hand was the most important condition a product needed to become emotionally durable. Pieces are fired to cone 10, approximately 2381 degrees Fahrenheit. Porcelain vitrifies at this temperature and makes it dense and durable.



Figure 42. Carved, Glazed, Porcelain Vessel

The focus of this division of research was to learn how to produce the designed objects in porcelain. There was an incredible amount of trial and error, and multiple failures. Porcelain is unpredictable to work with and cracks easily. The elliptical shape compounds this attribute, and I learned that the narrow sides of the ellipse are the most likely to crack during production. The thinner the wall of the product the more delicate it is to work with and more susceptible it is to cracking and warping during firing. Each of these characteristics can be

considered during the design phase to create a more streamlined production process.

Division III:

This research was conducted at Penland School of Crafts in Penland NC. I was fortunate to work with glass artist Jason Chakravarty in a two-week workshop that focused on kiln casting glass and aluminum. This combination was instrumental in exploring my designs for emotional durability in two additional materials that were previously not possible. Kiln casting was also adventitious since I could use a kiln to fire ceramics, as well as work with glass and metal. The workshop focused on using the lost wax method of casting. This is most commonly used in bronze art sculptures.

Each of the students brought work from home to work on during the class. I brought some of my hand carved vessels as well as some of my 3D printed ones. We were quick to get to work making silicone molds of our objects. I was able to create three molds to work with (figure 42). We would fill these molds with wax and they would become our positives for the casting process. The molds that I created were open face molds and are filled with wax. However, I did not need a solid cast of the vessels I was creating, only a thin shell.



Figure 43. Silicone Mold Making Process

Similar to slip casting porcelain, I filled the molds with wax and let them cool slightly. Then I would pour the excess wax out of the mold, leaving a wax shell. Initial attempts at creating this resulted in very thick bases and unrefined tops. Extremely hot days were affecting how the wax behaved. To speed up the hardening process I would place my molds in the freezer. This led me to try freezing the mold until it was ice cold before filling with wax. By doing this, the

wax was cooled quickly and evenly around the perimeter of the vessel and the excess could be poured off quickly. Producing the wax positive this way gave me the thinner more even wall that I was looking for and a much more refined vessel.

Once the waxes were worked to my desired effect i began the investment process. The investment was equal parts plaster and silica mixed with water into a thin paste. The investment was built up on my objects in thin layers to create a shell. I added fiberglass to some of the layers to increase the strength of the final molds. Once the pieces had a thick shell on them, I created a mold form from metal flashing that the piece would fit in. I then filled the mold with investment creating a hefty investment mold that housed the wax. Next I placed the molds upside down on top of a steamer to heat and melt the wax from the mold. De-waxed molds were then loaded into a kiln where they were slowly heated up to 1500 degrees Fahrenheit to completely dry them out and prepare them for accepting the glass. If I had been working in a glass studio I would have loaded glass cullet into the molds and it would have melted and fallen into the mold cavity. Since I was working in a glass blowing facility I had access to molten glass in a furnace. I ladled this glass into my molds in the heated kiln (Figure 43).



Figure 44. Kiln Casting Glass Process

Over the next 48 hours the kiln temperature would slowly be reduced until the pieces were completely cool, a process called annealing. This is an important process as it reduces stress in the glass and makes it strong. Skipping the process can leave the pieces unstable resulting in cracking or exploding from slight temperature changes.

Once the molds and the glass were completely cool we pulled away as much of the plaster as we could. When no more plaster could be removed I placed the mold in water to dissolve the remainder of the plaster, leaving the glass sculptures. However, I was not finished... I still needed to sand blast,

polish, and grind the pieces. Each of these processes would bring the surfaces of the pieces to life and give them a refined, finished feeling.

Aluminum casting was a secondary focus for this workshop. Initially I thought that I could place molds in the kiln and load them with aluminum ingots. Next I would bring the kiln to temperature and the aluminum would melt and drop into the mold, similar to the way that glass is cast. However, the aluminum did not melt and drop, once red hot the ingots held their shape. I allowed the kiln to cool to try a more traditional approach to metal casting. The molds were placed outside in a bed of sand as the aluminum was melted in a crucible in a glass furnace. This molten aluminum was then poured directly into the molds. I experienced molds cracking and leaking aluminum during this process (Figure 44).



Figure 45. Aluminum Casting Process

In the next set of molds that I created I embedded chicken wire in the plaster mix to hold the mold together. This solved the problem of cracked molds and allowed casting with more guaranteed results. Smaller objects were grouped onto a mold tree, but many of the smaller pieces did not come out successfully. From the aluminum casting research I was able to produce one complete failure (Figure

46) and one partial success (Figure 45). This was a nice addition to the glass casting since the process is similar. Our instructor created the casting trees for us. The manner in which they are created had a bearing on how well the castings turned out. This was a new process for all of us in the workshop including our instructor. Failures were to be expected and I feel fortunate to have this material exploration as part of this thesis. While products created in glass and aluminum were not finished and refined, the experience of casting has been beneficial in expanding my knowledge base for future product designs. Methods were also uncovered to better design products as well as molds to obtain more consistent results.



Figure 46. Aluminum Casting Process



Figure 47. Aluminum Casting Failure

Division IV:

Division four integrates the components and core themes identified during the first three divisions into a new product interpretation or creative synthesis. If I had the knowledge encompassing the difficulty and extreme expense of having others produce my line of tableware up front, I would have approached this thesis differently. The process of designing in the computer, 3D printing, and then slip casting was a very convoluted way to create products in clay. This Division takes the products I created and strips away all of the surface manipulation to look at the essence of the form. These elemental forms were then translated into a set of patterns in the computer and laser cut out of Baltic birch plywood. With this kit

of patterns and parts new forms could be created by hand using a slab building process. Porcelain was rolled out to approximately 1/16" thick and cut using the patterns created (Figure 47).



Figure 48. Slab Building Process

These pieces are then manipulated into three-dimensional forms. This method is much more straightforward in creating products and incorporates the mark of the hand in each piece. I identified earlier in my research process that this is an emotional durability ideal. The dominant idea in these products is to utilize a precious material, porcelain, and showcase the material's best attributes. Manipulating the material into ultra-thin sheets heightens the translucency and

makes the objects seem more precious. The material is exceptionally dense and strong, beguiling the delicate nature that is being portrayed. During the hand building process the porcelain is manipulated as little as possible. Clay has a memory and over-manipulating the form can lead to warping during firing. Minor flaws are left in place and rims are only smoothed out if they come in contact with the mouth. Some movement is to be expected during the firing process and this imperfect nature is to be celebrated and considered a positive design attribute (Figure 48). Based on research during the first three phases, this duality of refined and rustic will contribute to the emotional durability of the products



Figure 49. Slab Building Process



Figure 50. Slab Building Process

CHAPTER IV

ANALYSIS

My research has focused on creating kitchen objects that embody the principles of emotional durability, as discussed by Jonathan Chapman. I identified two of his research principles as the most relative for me to focus on in terms of product design: surface and narrative. Each of these principles could be singularly utilized in product creation, or combined to create a stronger sense of emotional durability. My design process has led me from designing forms that included historic precedent, to hand building forms that express emotional durability through a hand crafted surface.

Initially I focused on creating emotional durability by incorporating a historic narrative into each product. For example, the peppermill was based on the Venus of Willendorf, one of the oldest known manmade sculptures. This sculpture has associations with fertility and childbearing, or what I refer to as a "hip-ish" shape. This shape is pleasing to the human eye, naturally drawing us to the form. Including this narrative in the product connects the user with an idea that they are familiar with on a sub-conscious level. I utilized a historical narrative in each product I designed to elicit similar user responses in an effort to make them more emotionally durable.

To unify each of the products into a cohesive collection I chose to incorporate a fluted surface. This decision was derived from Philippe Starck's Juicy Salif juicer that was a launching point during the early design phase. I analyzed this form and noticed the surface was reeded rather than fluted like most juicers. The dialogue of reeded versus fluted was an engaging concept to me, specifically in how each surface could react to use over time. My intuition told me that if using raw brass as a material, a reeded surface would develop a soft patina and a fluted surface would develop a patina with high contrast. Touching the recesses of each flute is not easily accomplished due to their thin dimensions. This allows the recessed surface to darken and age over time. Conversely, oils present on human hands easily transfer to the high points during use, enabling the brass to retain a bright appearance. Daily interaction will show a pattern of use over time that is specific to the object and the user. This developing patina contributes to the emotional durability of the product by showing the history between the user and the object.

During the design phase I created a form as a 3D computer model. This helped me analyze and refine a model multiple times before continuing with further iterations. As part of the heuristic method, many of the changes that I made were based on my intuition. The heuristic method encourages the use of intuition to add "depth, substance, and essential meanings to the discovery process" (Moustakas, 23). My intuition also allowed me to visualize the completed products in various materials, as well as how they might age, or

develop a patina, over time. When products were first 3D printed in polylactic acid I was disappointed with them. Through a process of indwelling, also part of the heuristic method, I concluded that this lack of positive reinforcement was the choice of material. Polylactic acid was not a material in which I had chosen to explore my products, and would not develop a patina over time. I was using the material to create initial prototypes, not final products. Using these prototypes as a form to create molds from led me to another important discovery. Even though a machine is used to 3D print an object, it will have irregularities and an imperfect surface. This emerged during the glass-casting phase of research. Glass, which I had envisioned being smooth and polished emerged as a nubby, curious, and engaging surface. This is exactly the type of surface that invites a user to look deeper into its meaning and also hints at the way it was created which creates narrative.

Part of my process also involved creating products in porcelain. I approached this material with an open mind, knowing that I would have a learning curve during the making process. My openness as well as the slip casting process led me to carve the surfaces of the products I was making. During a critique, the individuality of the hand-touched surface emerged as a notable way for a product to have emotional durability. The final division of research aimed to simplify forms to their simplest essence and showcase porcelain. Surface carving was eliminated and products were hand built using paper-thin porcelain. Seams were overlapped, showing the pieces are

handmade, and celadon glazes showcase the form and the marks of the maker. Alternative glazes allow a surface to take on its own life. Glazes and oxides are layered in ways so that they will run and interact in a reduction kiln atmosphere to create unique, one of a kind surfaces on each object. Both of these techniques allow the individuality of each piece to shine. Users are encouraged to select pieces they are drawn to, beginning a relationship between the two. Encouraging the user/object relationship to evolve over time ensures an emotionally durable design.

Through the research process I ultimately learned that handcrafted products and the concept of individuality incorporate the most emotional durability in a product. Historical narratives that I initially included as a narrative provided me with a starting point for design yet fell short when used as the only narrative in a product. The most important narrative is one that a user can create with a product and can continue to evolve over time. Surfaces that can develop a patina and surfaces that show an individual or hand made quality successfully encourage a user to create a narrative and evolve with the object. This is the goal of emotional durability.

CHAPTER V

CONCLUSION

I began this design research process with a goal of understanding how to create products that are emotionally durable. Author and educator Jonathan Chapman has extensively researched the concept of emotional durability. I identified two areas of his research that contained the greatest number of positive attributes, surface and narrative. These ideas were used as design guidelines in creating a body of work centered on the ritual of dining.

In my literature review I explored product design, theory, history, and sense of place. This review gave me a thorough understanding of why we appreciate the products and places we do. Principles that are present in the practice of historic preservation parlay directly into product design. The scale changes from buildings to artifacts, yet the authenticity in materials and developed patinas are still highly sought after conditions. We create a sense of place in our homes and we surround ourselves with objects that exemplify our personalities. We utilize these objects in our daily rituals, and these rituals help us create a dialogue and history that we cherish. Some of the most celebrated modern designers design with these concepts in mind. We see a connection to

place in almost every design discussed in the precedent studies, as well as an invitation for the user to create a dialogue with each product.

During the design stages of this thesis I focused on creating objects that contained a narrative. Initially, materials were chosen to allow a surface patina to form with use over time. Early prototypes were 3D printed and seemed to lack soul. This changed when production moved from being out sourced to me producing the products myself. This change of production also greatly limited the materials that I could work with, influencing me to focus on porcelain. During this division of research, I discovered that hand carving the surface allowed a user to develop a dialogue with an object. The mark of the maker's hand became paramount in the creation of emotionally durable products. This carving is a tedious and time intensive process and with the intention of streamlining this process I created a group of dinnerware that was stripped down to the essence of the initial forms I created. This grouping focused on celebrating the material, porcelain, by creating impossibly thin products. This quality showcased the delicate nature as well as the durability of the material. Celadon glazes allowed the forms to be showcased and maker's marks to be highlighted. A secondary glaze technique was also developed that relinquished control over the surface to the atmosphere of the kiln. In these secondary glazed items the surface is a byproduct of a process, with each piece being unique. All of the products created invite the user to create a dialog and establish a personal history over time. Some products have a carved surface that fits just right into your hands,

while others tell a story of the creation with varying patterns seen in the glaze. While this group of kitchenware will not appeal to everyone, the goal was not to create mass-market objects for the world; rather, to create a grouping that will be emotionally durable to some users.

The workshop I attended at Penland School of Crafts was fast and intense. I learned that new materials take a considerable amount of time to understand and perfect. Creating prototypes in glass and aluminum gave me insight into how these materials can contribute to the embodied emotional durability in an item. Specifically with glass, the surface mimicked the 3D printed objects that they were molded from. The complex surface made it challenging to polish leaving some areas unpolished. This created a surface with a unique patina that light interacts with and enhances. The surface invites the user to further explore each of the glass vessels. The aluminum version is intriguing, yet lacks this invitation to explore, making it less emotionally durable.

Overall, working with multiple materials was challenging from a making standpoint. However, the process of learning to work with them and understanding their properties led to discoveries that were critical to the success of this research. We see a great interest arising to know where what we consume comes from, whether it is our food, clothing, or our kitchenware. Through this knowledge we gain a greater sense of place that is both more authentic and more meaningful. The kitchenware that I have created encourages the user to interact with them on a daily basis to celebrate the rituals

of dining, and to establish a more purposeful existence packed with emotional durability

Looking back many of my goals were unrealistic. I thought having artisans produce my products would be an excellent way to explore emotional durability. I was not prepared for the extreme cost and lack of ability to find individuals willing to do limited production runs in multiple materials. While the costs were prohibitive to myself, they would not be prohibitive to a company with a desire to take a product line to market. After attending the Penland glass workshop I know that the amount of time and effort required to produce my products warranted the steep price I was quoted. If I had known this initially, my path to create would have looked much differently. I envision that I would have immediately started working with hand building porcelain rather than creating complex designs in the computer. This process would have delivered different results. My process was convoluted and indirect to a ceramic artist, yet letting the process guide me resulted in the discoveries that I made along the way.

Moving forward I would like to further research the concept of emotional durability in product design using the product line I created. Conducting market research utilizing this line of goods would provide valuable information as to which attributes are most favorable to the greatest number of individuals. This research could be carried out via focus groups, questionnaires, and polls. Utilizing this data, the product line I created could be refined to reflect the learned input. Then it would be appropriate to work with artisans to produce the product

line to take to market. To gain exposure the line would be shown at trade shows such as the SOFA show in Chicago, the NYIGF show in New York, or other shows that would be deemed appropriate. Developing the line to this scale would require a substantial amount of capital making it necessary to partner with an individual willing to provide capital or creating a business plan and working with banks to obtain the capital.

The opportunities to further research emotional durability as well as take my product line to market are viable next steps. The lessons that I learned during my research will help guide me through the process setting it up for success.

REFERENCES

- Beveridge, P., Domènech, I., Pascual i Miró, E., & Bye, E. A. (2005). *Warm glass : a complete guide to kiln-forming techniques : fusing, slumping, casting*.
- Brierley, B. (2014). *Firing kilns*.
- Britt, J. (2007). *The complete guide to high-fire glazes : glazing & firing at cone 10*. New York: Lark Books.
- Bullock, J. N., Ohio, L. E. T., & Dissertations, C. (2012). Design principles for emotional durability. Retrieved from http://rave.ohiolink.edu/etdc/view?acc_num=ucin1342103850
- Burke, A., & Hewett, B. (2010). Contingent geometries: developing design strategies for complex systems. *Architectural theory review: journal of the Department of Architecture, the University of Sydney*, 15(2), 201-209.
- Burke, E., & Kendall, G. (2005). Search methodologies : introductory tutorials in optimization and decision support techniques.
- Chapman, J. (2006). Modern life is rubbish. *Blueprint (London, England)*(241), 68.
- Chapman, J. (2009). Design for (Emotional) Durability. *Design Issues*, 25(4), 29-35.
- Chapman, J. (2015). *Emotionally durable design : objects, experiences and empathy*.
- Chapman, J., & Gant, N. (2007). *Designers, visionaries and other stories : a collection of sustainable design essays*. London; Sterling, VA: Earthscan.
- Clayton, P. (2001). *The clay lover's guide to making molds : designing, making, using*. Asheville, N.C.; Poole: Lark ; Chris Lloyd.

- Conrad, J. W. (1973). *Ceramic formulas : the complete compendium; a guide to clay, glaze, enamel, glass, and their colors*. New York: Macmillan.
- De Bolla, P. (2002). Toward The Materiality of Aesthetic Experience. *Diacritics*, 32(1), 19-37.
- Denzin, N. K. (2009). The elephant in the living room: or extending the conversation about the politics of evidence. *Qualitative Research*, 9(2), 139-160. doi:10.1177/1468794108098034
- Derix, C., & Izaki, Å. (2013). Spatial computing for the new organic. *Architectural design*, 83(2), 42-47.
- Dixon, T. (2009). *Tom Dixon : interior worlds*. New York: Rizzoli.
- Doherty, J. (2002). *Porcelain*. London: A. & C. Black.
- Forrest, T., & Atterbury, P. (1998). *The Bulfinch anatomy of antique china & silver : an illustrated guide to tableware, identifying period, detail, and design*. Boston: Bulfinch Press.
- Gershkovich, T. (2013). Infecting, Simulating, Judging: Tolstoy's Search for an Aesthetic Standard. *Journal of the History of Ideas*, 74(1), 115-137.
- Groat, L. N. W. D. (2013). *Architectural research methods*. New York: J. Wiley.
- Gross, S., Bardzell, J., & Bardzell, S. (2014). Structures, forms, and stuff: the materiality and medium of interaction. *Personal & Ubiquitous Computing*, 18(3), 637-649. doi:10.1007/s00779-013-0689-4
- Harrod, T. (2013). Visionary rather than practical: : craft, art and material efficiency. *Philosophical Transactions of the Royal Society A: Mathematical, Physical & Engineering Sciences*, 371(1986), 9-9. doi:10.1098/rsta.2011.0569
- Hensel, M., & Menges, A. (2006). Material and digital design synthesis: integrating material self-organisation, digital morphogenesis, associative parametric modelling and computer-aided manufacturing. *Architectural design*, 76(2), 88-95.
- Hudson, N. F. (2010). Changing places: the archaeology of the Roman 'convivium'. *American journal of archaeology*, 114(4), 663-695.
- Julier, G. (1991). Spain's social settings. *World architecture*(15), 73-77.

- Koren, L. (2008). *Wabi-sabi for artists, designers, poets & philosophers*.
- Lacey, E. (2009). Contemporary Ceramic Design for Meaningful Interaction and Emotional Durability: A Case Study. *International Journal of Design*, 3(2).
- Lane, P., & Lane, P. (2003). *Contemporary studio porcelain*. London; Philadelphia, Pa.: A & C Black ; University of Pennsylvania Press.
- Lowenthal, D. (1985). *The past is a foreign country*. Cambridge [Cambridgeshire: Cambridge University Press
- Mackenzie, D. (2013). Parametric + algorithmic design: the designer of Point Resolution Bridge, Dean Mackenzie, discusses the parametric modelling of this and other bridges Warren and Mahoney has designed for locations around New Zealand; he also explains the parametric modelling of several projects designed while he was working for Skidmore, Owings & Merrill (SOM) in New York. *Architecture New Zealand*(6), 71-75.
- Mahdjoubi, D. (2003). Epistemology of Design. *Integrated Design and Process Technology*.
- Mayes, Tom. "National Trust for Historic Places: Return to Home Page." *Blog Series: Why Do Old Places Matter? - Preservation Leadership Forum - A Program of the National Trust for Historic Preservation*. National Trust for Historic Preservation, 30 Mar. 2016. Web. 04 Aug. 2016.
- Molotch, H. L. (2003). *Where stuff comes from : how toasters, toilets, cars, computers, and many others things come to be as they are*. New York: Routledge.
- Moore, K. D., & Geboy, L. (2010). The question of evidence: current worldviews in environmental design research and practice. *arq: Architectural Research Quarterly*, 14(02), 105-114.
doi:doi:10.1017/S1359135510000722
- Moustakas, C. E. (1990). *Heuristic research : design, methodology, and applications*. Newbury Park: Sage Publications.
- Murfitt, S. (2002). *The glaze book*. Iola, WI: Krause Publications.
- Norberg-Schulz, C. (1980). *Genius loci : towards a phenomenology of architecture*. London: Academy Editions.

- Norman, D. A. (1988). *The psychology of everyday things*. New York: Basic Books.
- Norman, D. A. (2004). *Emotional design : why we love (or hate) everyday things*. New York: Basic Books.
- Norman, D. A. (2007). *The design of future things*. New York: Basic Books.
- O'Rourke, M. (2010). *Clay, light & water*. London; Philadelphia: A & C Black ; University of Pennsylvania Press.
- Picon, A. (2011). Substance and styles: the Autopoiesis of Architecture vol 1: a New Framework for Architecture - a treatise by Patrik Schumacher, partner in Zaha Hadid Architects, promises nothing less than a wholly new theoretical approach to architecture. Antoine Picon admires the ambition, but questions the conclusions. *Architecture today*(216), 4-4.
- Picon, A. (2011). When parametricism tries to reconnect with Vitruvius: Autopoiesis of architecture, vol.1: a new framework for architecture [by] Patrik Schumacher. *Log*(23), 53-57.
- Taylor, B., & Doody, K. (2014). *Glaze : the ultimate ceramic artist's guide to glaze and color*.
- Taylor, B., & Doody, K. (2014). *Glaze : the ultimate ceramic artist's guide to glaze and color*.
- Taylor, J. R., Bull, A. C., & Institute of, C. (1986). *Ceramics glaze technology*. Oxford [Oxfordshire]; New York: Published on behalf of the Institute of Ceramics by Pergamon Press.
- Thompson, S. (2009). Joey: a design scenario for an ordinary life in the future. *Technoetic Arts: A Journal of Speculative Research*, 7(1), 13-29.
doi:10.1386/tear.7.1.13_1
- Thun, M. (2010). Wood in architecture, interior and product design - a homage to a building material. *Detail (English ed.)*, 6, 554-558.
- Thwaites, A. (2011). *Mould making for glass*. London: A & C Black.
- Van Gorp, T., & Adams, E. (2012). *Design for emotion*. Waltham, MA: Morgan Kaufmann.

- Wallendorf, M., & Arnould, E. J. (1991). "We Gather Together": Consumption Rituals of Thanksgiving Day. *Journal of Consumer Research*, 18(1), 13-31.
- Wardell, S. (2007). *Slipcasting*. London: A. & C. Black.
- Wells, J. C. (2007). *The plurality of truth in culture, context, and heritage: A (mostly) post-structuralist analysis of urban conservation charters*. (City et time / Centro de Estudos Avançados da Conservação Integrada
- Williams, G. (1996). Technical: wood as primary structure. *Canadian architect*, 41(7), 27.
- Yanli, C., Elizabeth, S. T., Pauline, M. S., & Grace, N. M. (2003). Cause-related marketing: how generation Y responds. *International Journal of Retail & Distribution Management*, 31(6), 310-320.
- Yongqiang, G. (2009). Corporate social responsibility and consumers' response: the missing linkage. *Baltic Journal of Management*, 4(3), 269-287.
- Zuidgeest, J., Burgh, S. v. d., & Kalmeijer, B. (2013). Planning by parameters. *Architectural design*, 83(2), 92-95.

APPENDIX A
IMAGE SOURCES

All images are by the author unless otherwise stated below.

Figure 1: <http://www.stilsucht.de/images/11-2010/mark-braun-bowl-set-one-3.jpg>

Figure 2: https://www.yatzer.com/sites/default/files/article_images/2607/fortune-by-Mark-Braun-21-Carafes-showing-international-waters-yatzer-16.jpg

Figure 3: http://aam.vasku-klug.com/wp-content/uploads/2014/02/Drinking-Set-No.283-gold_Lobmeyr_Braun.jpg

Figure 4: <http://www.tomdixon.net/media/wysiwyg/heritage/s-chair-1>

Figure 5: http://www.tomdixon.net/media/wysiwyg/Stories/tom_dixon_the_great_chair_grab_trafalgar_square_4_web_0

Figure 6: <http://www.sothebys.com/content/dam/stb/lots/L08/L08675/L08675-46-lr-1>

Figure 7: http://cdn.shopify.com/s/files/1/0857/1790/collections/revolution_collection_1024x1024.jpg?v=1457965729

Figure 8: http://cdn.shopify.com/s/files/1/0857/1790/products/lift_1_of_4_1024x1024.jpg?v=1458743680

Figure 9: http://cdn.shopify.com/s/files/1/0857/1790/products/01_ahn_table_1024x1024.jpg?v=1458158868

Figure 10: http://hivemodern.com/public_resources/louis-ghost-chair-philippe-starck-kartell-1

Figure 11: https://reps01.s3.amazonaws.com/product_detail_big_catalogue_4c835fe8aa03efa8d87eac921200098b0154f469

Figure 12: http://www.alessi.com/alessiwords/wpcontent/uploads/2015_05_PSJStovaglietta

APPENDIX B
BODY OF WORK







