

South Dakota State University

# Open PRAIRIE: Open Public Research Access Institutional Repository and Information Exchange

---

Electronic Theses and Dissertations

---

2020

## Characterization of Bison Finishing and Harvest Systems: Effects on Carcass and Meat Quality Characteristics

Jessica Janssen

*South Dakota State University*

Follow this and additional works at: <https://openprairie.sdstate.edu/etd>



Part of the [Beef Science Commons](#)

---

### Recommended Citation

Janssen, Jessica, "Characterization of Bison Finishing and Harvest Systems: Effects on Carcass and Meat Quality Characteristics" (2020). *Electronic Theses and Dissertations*. 4186.

<https://openprairie.sdstate.edu/etd/4186>

This Thesis - Open Access is brought to you for free and open access by Open PRAIRIE: Open Public Research Access Institutional Repository and Information Exchange. It has been accepted for inclusion in Electronic Theses and Dissertations by an authorized administrator of Open PRAIRIE: Open Public Research Access Institutional Repository and Information Exchange. For more information, please contact [michael.biondo@sdstate.edu](mailto:michael.biondo@sdstate.edu).

CHARACTERIZATION OF BISON FINISHING AND HARVEST  
SYSTEMS: EFFECTS ON CARCASS AND MEAT QUALITY  
CHARACTERISTICS

By

JESSICA JANSSEN

A thesis submitted in partial fulfillment of the requirements for the

Masters of Science

Major Animal Science

South Dakota State University

2020

## THESIS ACCEPTANCE PAGE

Jessica Janssen

This thesis is approved as a creditable and independent investigation by a candidate for the master's degree and is acceptable for meeting the thesis requirements for this degree.

Acceptance of this does not imply that the conclusions reached by the candidate are necessarily the conclusions of the major department.

Amanda Blair

Advisor

Date

Joseph P Cassady

Department Head

Date

Dean, Graduate School

Date

## ACKNOWLEDGEMENTS

Thank you to my advisor, Dr. Amanda Blair. My decision to come to SDSU for grad school in the first place was because of her, and I owe the majority of my academic success to her. But it doesn't just end there, Dr. Blair never hesitated to open up her home and family to me over these past two years, which means a lot when your home is 12 hours away. She has served as trustworthy mentor both for academic and personal matters, in which I am internally grateful for. I couldn't imagine pursuing a graduate program under anyone else. Thank you to Dr. Kyle Grubbs for always allowing us graduate students to come gather in his office for whatever reasons to talk about meat science topics, classes, or teaching assistant duties. Thanks to Dr. Keith Underwood who was always there to answer my random questions about my project or meat science. Thank you Dr. Gregory Howard for your time commitment to serve as my graduate faculty representative. This project would not be possible without Turner Enterprises Inc. for providing the funds to support this research. A special shout out to John Hansen, Dr. Carter Kruse, Billy Salada, and Bob Wesley. Thank you to Bob Dineen and Ace Ward Brush Meat Processors and Rocky Mountain Natural Meats for working with us and allow our Meats group to come into your commercial facilities to take data collections. Thanks Dan O' Brian with Wild Idea Buffalo for also allowing us to come in your processing facilities as well to conduct carcass data collections. Thank you to Dr. Jerrad Legako with Texas Tech University for allowing fellow grad student Erin and myself to come down and work with you in your lab for fatty acid profile and cholesterol determination analyses, and collaborating on the study. Thank you to Dr. Willy Horne with USDA-AMS for agreeing to work with us and utilizing the carcass grading camera on the bison. Thank you to Loma, Loren, Dr. Zata Vickers, and Dr. Ryan Cox at the University of Minnesota for working with us to conduct our consumer sensory panel. Thank you to our awesome team of expert USDA graders which included Darryl Dowd, Leonard Woody, and Dr. Horne for taking our carcass measurements and camera images on 201 head of bison. A big thanks to Dr. Kristi Cammack as she was willing to further teach me for working in SAS, as well as willing to collaborate on statistical analysis inquiries for the project. Thank you to Dr. Jeff Clapper with the Animal Physiology Lab within our department for running the cortisol assays for the bison serum samples. Thank you to Dr. Chris Chase with our Vet Diagnostics Department here at SDSU and Karim for teaching and guiding me through conducting the haptoglobin assays. Thank you to Jason Griffin with the Ruminant Nutrition lab here within our department, for assisting me in the lab for conducting proximate analysis. Also thank you to Dr.s Ken Olson and Jamie Brennan for providing comical entertainment and conversations during my visits out to the West River Center. A huge thank you to our meat science group at SDSU. Thank you to meat lab manager Adam Rhody for always being there to help, and also thank you to all the meat science graduate students that I have worked closely with over the past 2 years: including Erin Gubbels, Lydia Hite, Austin and Sam Egolf, Trevor DeHaan, and Dr. Chris Bakker. To my friends and family at home, thanks so much for all your love, and support. your encouraging phone calls always helped keep me motivated and focused. And finally a special thanks to my fiancé, George: I cannot thank you enough for all your patience and support for the past 2 years, you practically endured this process with me, even though we were 9 hours away majority of the time.

## TABLE OF CONTENTS

LIST OF FIGURES.....	vi
LIST OF TABLES.....	vii
ABSTRACT.....	ix

### **CHAPTER 1: *BISON BISON* LITERATURE REVIEW**

Species and Industry Overview.....	1
Current Bison Industry.....	2
Seasonal Activity Patterns.....	2
Carcass Characteristics of Bison.....	4
Nutrient Composition.....	7
Meat Quality Attributes.....	9
Harvest Systems.....	17
Finishing Systems.....	21
Literature Cited.....	28

### **CHAPTER 2: CARCASS CHARACTERISTICS, MEAT QUALITY, NUTRITIONAL COMPOSITION, AND CONSUMER PREFERENCE OF GRAIN- AND GRASS- FINISHED BISON HEIFERS**

Abstract.....	36
Introduction.....	38
Materials and Methods.....	39
Results and Discussion.....	50
Conclusion.....	70
Literature Cited.....	71

**CHAPTER 3: A TECHNICAL NOTE: UTILIZATION OF CAMERA GRADING TECHNOLOGY FOR BISON CARCASS CHARACTERISTICS**

Abstract.....	96
Introduction.....	98
Materials and Methods.....	99
Results and Discussion.....	103
Implications.....	105
Literature Cited.....	106

**CHAPTER 4: ANIMAL STRESS RESPONSE, CARCASS CHARACTERISTICS, MEAT QUALITY, AND CONSUMER PREFERENCE OF GRASS BISON HEIFERS HARVESTED IN MOBILE OR COMMERCIAL ABATTOIRS**

Abstract.....	122
Introduction.....	124
Materials and Methods.....	125
Results and Discussion.....	129
Conclusion.....	137
Literature Cited.....	138

**APPENDIX**

Appendix A: Consumer Sensory Ballot.....	147
Appendix B: Additional Consumer Sensory Results.....	150
Appendix C: Consumer Sensory Participant Demographics.....	152

## LIST OF FIGURES

- Figure 2-1.** Least square means for the effect of finishing system on tenderness of bison striploin steaks.....93
- Figure 2-2.** Least square means for the effect of postmortem aging on tenderness of bison striploin steaks. All steaks stored frozen prior to analysis.....94
- Figure 2-3.** Least square means of cook loss for the interaction of days postmortem aged and finishing system effects on bison striploin steaks.....95

## LIST OF TABLES

<b>Table 2-1.</b> Least squares means for effect of finishing system on live weight and carcass characteristics of grain- or grass-finished bison heifers.....	86
<b>Table 2-2.</b> Least squares means for effect of finishing system on objective color measurements and ultimate pH of grain- or grass-finished bison heifers.....	87
<b>Table 2-3.</b> Least square means for the effect of finishing treatment on the proximate nutrient composition of raw tissue from the <i>longissimus dorsi</i> of grain- or grass-finished bison heifers.....	88
<b>Table 2-4.</b> Least square means for the effect of finishing treatment on the fatty acid composition of raw tissue from bison <i>longissimus dorsi</i> of grain- or grass-finished bison heifers.....	89
<b>Table 2-5.</b> Least squares means for effect of storage conditions on tenderness of striploin steaks from grain- and grass-finished bison.....	91
<b>Table 2-6.</b> Least square means for the effect of finishing treatment on subjective meat quality attributes rated by a consumer sensory panel (n=113 participants).....	92
<b>Table 3-1.</b> Correlations of bison carcass characteristics between VBG2000 image processing system and USDA expert grader evaluations.....	108
<b>Table 3-2.</b> A comparison of least squares means for effect finishing systems on bison	



carcass characteristics VBG2000 image processing system and USDA expert grader evaluations.....	109
<b>Table 3-3. Yield Grade Ranges.</b> Carcass camera parameters and corresponding grader evaluations for selected ribeye images.....	117
<b>Table 3-4. Marbling Scores Ranges.</b> Carcass camera parameters and corresponding grader evaluations for selected ribeye images.....	119
<b>Table 3-5. Ribeye areas.</b> Carcass camera parameters with corresponding grader evaluation and ribeye images.....	121
<b>Table 4-1.</b> Least square means for effects of harvest system on haptoglobin and cortisol serum content of bison heifers.....	143
<b>Table 4-2.</b> Least squares means for effect of harvest system on live weight, carcass characteristics, and objective color of bison heifers harvested on-ranch using a mobile slaughter unit or at a commercial packing facility.....	144
<b>Table 4-3.</b> Least squares means for effect of harvest systems on meat quality characteristics of bison <i>longissimus dorsi</i> .....	145
<b>Table 4-4.</b> Least square means for the effect of harvest systems on subjective meat quality attributes rated by a consumer sensory panel (n=113 participants).....	146

## ABSTRACT

The objectives of this thesis project were to 1) characterize the influence of finishing system (grain-finished vs. grass-finished) on carcass characteristics, meat quality, the nutritional composition, and consumer preference for bison meat 2) evaluate the effectiveness of beef camera grading technology on grain- and grass-finished bison carcass characteristics, and 3) characterize the influence harvest systems (on-ranch vs. commercial facilities) on animal stress response, carcass characteristics, meat quality, and consumer preference of bison heifers. For objectives 1 and 2: Grain- (n=108) and grass- (n=93) finished bison heifers were slaughtered at 28 mo of age, at approximately 20 h postmortem, carcass measurements and camera images were recorded, and striploins were collected from a subsample of carcasses (n=30 carcasses closest to the treatment average hot carcass weight) for meat quality analyses. For objective 2, grass-finished bison heifers were randomly assigned to harvest treatments: Commercial (n=93, transported ~720 km to a commercial harvest facility) or On-ranch (n = 40, harvested on-ranch using a mobile slaughter unit). Blood samples were collected immediately following exsanguination, carcass measurements were recorded, and striploins were collected from a subsample of carcasses (n=30 carcasses closest to the treatment average hot carcass weight). For objective 1, finishing systems influenced bison carcass characteristics and meat quality; however, there was no differences detected between finishing systems for consumer preferences. Additionally, finishing systems influenced nutrient content and fatty acid composition, which may have health implications; as grass-finished steaks had decreased fat and cholesterol content, but increased proportions of polyunsaturated fatty acids compared to grain-finished steaks. For objective 2, bison

ribeye images collected with a beef grading camera were correlated with expert grader evaluations, however the camera was more efficient at determining yield grade parameters, and had difficulties measuring marbling. Accuracy of measurements and validation of a suitable camera grading system for bison will require additional investigation, including calibration and adjustments for bison carcass characteristics. For objective 3, harvest systems influenced short-term stress response, and some carcass and meat quality characteristics of bison heifers. However, harvest systems had minimal impact on consumer preference for bison.

## CHAPTER 1: LITERATURE REVIEW: *BISON BISON*

### **Species and History Overview**

Bison (*Bison bison*) are a species native to North American and are classified under the family Bovidae, which are described as even toed ungulates and includes other species such as antelopes, cattle, gazelles, goats, and sheep (Animal Diversity Web 2019). Two common subspecies in North America include the Plains bison (*Bison bison bison*) and Woods bison (*Bison bison athabascae*). Bison are a non-domesticated species that have become highly adapted to the weather and grass species of the Great Plains region.

In North America, there were approximately 30 million bison when the first European explorers arrived. (National Bison Association (NBA): Current Status, 2020). Numbers dwindled to approximately 1,000 head in the 1880's, due to excessive hunting by North American settlers and disease brought by their domesticated animals (NBA: Current Status, 2020; Galbraith et al., 2014). This caused the specie to face near extinction, and the prospect of extinction initiated vigorous conservation efforts by individual producers such as Michel Pablo, C.J. "Buffalo" Jones, Charles Goodnight, and Scotty Phillip to help preserve the species (Galbraith et al., 2014). However, these individual efforts to help protect the species involved several experiments such as crossbreeding bison with cattle to create a hybrid that was better adapted to the climatic and economic conditions of the northern temperate zones (Koch et al. 1995). Early research reports on crosses between the two species identified fertility issues in males

(Jones, 1907; Boyd & Goodnight, 1914). These undesirable results limited the pursuit of creating a beef/bison hybrid.

### **Current Bison Industry Status**

Currently it is estimated that there are approximately 400,000 bison in North America, including private, state, federal, and tribal herds, however 90% of bison reside in private herds (NBA Current Status, 2020). Raising bison has potential economic advantages compared to domesticated ruminants, due to low inputs, longer animal lifespans, their natural ability to utilize native grass species, and adaptation to climate change (Galbraith et al., 2014). However, unlike other domesticated species, raising bison has unique management practices. Today the National Bison Association (NBA) has an established Code of Ethics that specifically prohibits its members from crossbreeding bison with another species to help sustain purity of the species (NBA: Code of Ethics, 2019). Additionally, the NBA code of ethics limits the use of genetic selection, antibiotics or vaccinations, and breeding technologies. Regulations also restrict the use of the hormonal implants (NBA: Code of Ethics, 2019). Bison are larger animals that can show increased signs of aggression and can become easily excited. Such behavior requires improved working and housing facilities as well as stronger and taller fencing in pastures to ensure proper management and safety (NBA: Current Status, 2019). The remainder of the review will include current knowledge to better understand the bison species, including topics of: seasonal activity patterns, carcass characteristics, nutritional composition, meat quality, harvest systems, and finishing systems. Additionally, beef studies focused on nutritional composition and meat quality will be included when relevant and bison studies are lacking.

## Seasonal Activity Patterns

Bison are a wild ruminant species that are generally noted for their ability to adapt and survive in harsh environments. Commonly wild ruminants alter their daily activity patterns in response to seasonal fluctuations in forage biomass and environmental temperature (Rutley & Hudson 2001). During cold seasons, bison have a reduced voluntary intake and growth, but recover in the subsequent warmer seasons. The impact of seasonal effects on bison growth and development, or the “winter slump” is defined by Huntington et al. (2019) as periods of decreased temperatures and sunlight hours, which in turn diminishes feed supply, causing decreases in animal intake, digestion rates of the rumen, and overall body weight. These annual fluctuations in body weight occur in both growing and mature bison. The change to warmer seasons brings longer periods of sunlight, which stimulates plant growth causing animals to gain body weight and condition. As a result, bison exhibit seasonal growth and reproductive patterns.

Other ungulate species such as deer, elk, moose, and caribou show similar feeding and reproductive activity patterns (Parker et al., 2009). In their review of elk, Hudson & Haigh (2002) hypothesized that metabolic and physiological responses to shorter phototropic periods during the colder seasons originated in the endocrine and neural systems due to changes of prolactin, melatonin, and thyroxine release and production. Research suggests that bison are also impacted by the shorter photoperiods, and that these seasonal changes interact with other factors such as body condition before winter, severity of weather change, availability of feed, disease pressure, and predators (Hudson and Haigh, 2002; Parker et al., 2009; Jesmer et al., 2017). Christopherheron et al. (1976) compared the critical temperature and thermal insulation by calculating the metabolic

responses of bison, yak, Scottish Highlander, and Hereford calves, at 20, 0, and -30 °C. Bison calves had a lower metabolic rate, especially at cold temperatures, compared to yaks, Hereford, and Scottish Highlander cattle. Typically, most species increase metabolic rates to offset heat loss, however bison responded by lowering their rates, which could be considered an adaptive characteristic to extreme cold temperatures (Christopherherson et al., 1976).

The influences of season and diet on feedlot performance of bison was evaluated by Anderson and Miller (1997). The study used bison bull calves randomly assigned to four different feedlot diets and seasons. Feeding periods were approximately 80 d long and closely corresponded with spring, summer, fall, or winter seasons. Average daily gains were highest in the fall (0.80 kg), and winter gains (0.17 kg) were significantly lower than any other season. Previous research by Christopherson et al. (1979) suggests that differences in gains observed between seasons could be attributed to photoperiod and cold temperatures, however bison are generally cold tolerate, which would suggest photoperiod may have a greater impact. Hay intake increased on a per-head basis during winter. Anderson and Miller (1997) speculate that increased intakes of hay during the winter may be an evolutionary response as a method of increasing body heat production. Total dry matter feed intake per head increased for spring, summer, and fall seasons, indicating that bison undergo a preparatory growth before winter. Conclusions made from this study imply that season does have a major impact on gain and efficiency for bison, as they are naturally inactive in winter causing their intakes to decrease even when feed is readily available.

### **Carcass Characteristics of Bison**

The anatomy and conformation of bison carcasses differs slightly than beef carcasses, however measurement protocols for bison carcasses are similar to beef. In the United States, bison are classified as non-amenable or “exotic” species, carcass inspection is voluntary and can be conducted by USDA-FSIS or FDA equivalent service, and there is no established carcass yield or quality grading system for bison. However, in Canada producers have the opportunity to market their bison through a standardized grading system.

### ***Anatomy and Weight Characteristics***

Carcass anatomy of bison includes large thoracic processes that create the classic hump of bison. Bison also have 14 ribs per side compared to 13 in beef cattle. Peters (1958), Hawley (1986), and Koch et al. (1995) all report that bison have decreased hindquarter weight relative to beef cattle, as the majority of muscling is carried in the forequarter of bison. Koch et al. (1995) describes the fat distributions of bison carcasses to be less uniform than beef and found that bison carry a higher percentage of fat over the rib cut than beef. Overall total retail fat trim is increased in bison carcasses compared to beef carcasses. Increased percentage of fat over rib may have evolved as a storage depot for energy to be utilized as protection from a cold environment (Koch et al., 1995). Hawley (1986) also reported that bison steer carcasses have large fat deposits in the subcutaneous layer over the ribs and surrounding the kidneys. Bison generally have a smaller ribeye area compared to cattle. Hawley reported a ribeye area of 60.5 cm<sup>2</sup> for bison steers, while Spronk et al. (undated) reported ribeye areas of 61.2 cm<sup>2</sup> for bison heifers and 67.4 cm<sup>2</sup> for bison bulls.



Generally, bison are slaughtered at lighter body weights than cattle, resulting in a lighter hot carcass weight. Koch et al. (1995) reported that the initial weight of bison was 64 kg less than cattle, and they were up to 146 kg lighter at the end of the finishing period. The lighter initial and slaughter weights of bison was designed to keep them at similar carcass maturity levels, yet bison still required an extra 58 d on feed to reach their targeted market weight, indicating that bison might achieve market readiness at a later chronological age than beef. Slaughtering bison at older chronological age is common across various finishing systems. Several studies have reported slaughtering concentrate fed bison steers and pasture raised bulls at 30 mo of age (Hawley, 1986; Marchello et al., 1998; Marchello and Driskell, 2001), and Rule et al. (2002) slaughtered range-raised bison bulls at 31 mo of age. Marchello et al. (1989) finished bison bulls and heifers in different feeding systems that were slaughtered at ages ranging from 24 to 36 mo.

### ***Canadian Bison Carcass Grading System***

The current Canadian Bison Grading system has 10 bison grades dispersed into two different maturity classes: A1-4 and B1-3 described as “youthful,” and D1-3, described as “mature.” Physiological maturity is determined by the degree of ossification present on the cartilage caps over the ends of the 9<sup>th</sup>, 10<sup>th</sup>, and 11<sup>th</sup> thoracic processes, where youthful carcasses have 80% or less ossification of the caps (Galbraith et al., 2014). Additional grading measurements include muscle firmness and color, as well as fat color, firmness, and thickness. For accessing quality attributes, the Canadian Bison Association considers carcasses classified as youthful to be most tender, with muscle and fat color, thickness, and texture that meets consumer acceptance. Therefore, bison

carcasses grading in the “A” category have excellent to good muscling, fat color is white to amber and firm, lean color is bright red and firm, and fat thickness measures 2-18 mm at the 11<sup>th</sup> rib [Canadian Bison Association (CBA) 2019, and Galbraith 2014]. The Canadian Bison Association also notes that marbling is not included within their grading system because bison carcasses exhibit very limited marbling. Koch et al. (1995) reported bison to have a marbling score of 319, which was less than the average score of *Bos taurus* (386), or the *bison x bos* hybrid (449) in that study. Spronk et al. (undated) reported marbling scores for bison bulls at 268 and heifers at 317. Marbling scores in these studies would qualify the carcasses as either USDA Select or Standard using the USDA beef quality grading system.

### **Nutrient Composition**

Consumption of red meat products are often negatively associated with elevated cholesterol levels and increased risk of cardiovascular-related diseases. These associations are often attributed to the fatty acid profile of meat, specifically the saturated fatty acid content. Early research studies conducted on bison nutrient composition concluded that bison meat is generally low-fat with elevated polyunsaturated fatty acid (PUFA) content compared to beef when reared similarly (Larick et al., 1989). These positive nutritional attributes are highly promoted by the bison industry, which creates appeal to diet and health conscious consumers. Though previous research indicates bison nutrient profiles may differ from beef, it is important to recognize that nutrient composition of bison meat can be influenced by several factors including, finishing systems, animal gender, and the specific cut evaluated. Serving size and intake patterns will also impact the nutritional benefits connected to consumption of bison meat.

Fatty acids are classified by the presence of double bonds and the number of carbons within the chain. There are three main categories of fatty acids; saturated, monounsaturated and polyunsaturated. A majority of red meat products consist of saturated and monounsaturated fatty acids. Saturated fatty acids (SFA) do not include a double bond, and medium length chains (12-16 carbon chain lengths) are generally considered to have negative effects on cholesterol levels and cardiovascular disease (Institute of Medicine, 2005; Dietary Guidelines Advisory Committee, 2010). The most abundant SFA in red meat is stearic acid (C18:0), which has been shown to have neutral effects on cholesterol, distinguishing it from other cholesterol raising SFA (Dietary Guidelines Advisory Committee, 2010). Monounsaturated fatty acids (MUFA) contain one double bond and the position of the double bond creates either cis or trans isomers. Oleic acid (C18:1) is the most abundant MUFA in red meat products. The content of oleic acid increases as marbling cells multiply (Van Elswyk & McNeill, 2014), and therefore is typically associated with influencing overall palatability in beef. PUFAs contain at least two double bonds. Content of PUFAs within red meat is generally low, averaging approximately 5% of total fatty acids in beef species (Scollan et al., 2006). The n-6 family are the most common PUFA structures, specifically linoleic acid (C18:2n-6, omega-6). The n-3 family is also present, but in decreased amounts compared to n-6 structures, with alpha-linolenic acid (C18:3n-3, omega-3) found to be most common. Both the omegas are considered essential as they support dermal structure in tissues and contribute to the synthesis of long chain PUFAs (LCPUFA) such as arachidonic (C20:4n-6) and docosahexaenoic (DHA, C22:5n=3). However, detection of LCPUFA content can be restricted due to the inability of ruminants to accumulate significant amounts of n-3

LCPUFA due to the biohydrogenation of dietary unsaturated fatty acids, which is part of normal rumen function (Scollan et al., 2006).

An early study by Larick et al. (1989) evaluated the influence of genetic differences between the species of *Bison bison*, *Bos taurus*, and *Bos indicus* on fatty acid profiles corresponding to the neutral lipid (NL) and phospholipid portions (PL) of the loin. Steers of similar age from each species were finished on an identical concentrate diet and slaughtered at 18 mo of age. Ether extract results ranked *Bos taurus* highest for total fat content (5.3%), followed by *Bos indicus* (3.4%), and then bison (2.7%). Fatty acids in the NL fraction were elevated in bison samples, and bison samples contained lower levels of myristic and myristoleic acids than both cattle species, and lower palmitic levels than *Bos taurus* (Larick et al., 1989). Stearic, linoleic, and total PUFA content within the NL was increased in bison compared to *Bos indicus*, and total PUFA was increased compared to *Bos taurus*. Samples from bison contained the largest PL values, in which the fractions were largely composed of MUFA and PUFA. Larick et al., (1989) concluded that species and breed-type influenced fatty acid composition of muscle tissue and the increased levels of PUFA in bison could contribute to the flavor profile of meat products.

### **Meat Quality Attributes**

Meat quality attributes represent the factors that influence palatability and a consumer's overall eating experience. These attributes include, meat appearance, aroma, flavor, juiciness, and tenderness, which are often evaluated using a combination of subjective and objective methods (Adegoke and Falade 2005). Properties of meat and their resulting quality are influenced by many factors ranging from antemortem animal

management, conversion of muscle to meat, postmortem handling, and method of preparation. Understanding meat quality characteristics and factors that influence them allows for the meat industry to better provide a product to readily meet consumer demand. Several credence attributes are routinely claimed on bison meat products including: no added hormones, no antibiotics, exotic regenerative, grass-fed, and deliciously healthy (NBA: Bullish on Bison, 2019). Consumers may be intrigued by the credence and nutritional attributes of bison meat, however there is limited scientific evidence regarding consumer preferences for bison meat. These credence attributes do not address consumer's preferences for tenderness, juiciness, or flavor characteristics of bison meat. There is limited consumer sensory research focused on the fresh meat quality attributes of bison.

### ***Meat Color***

Meat color is a meat quality characteristic initially evaluated by consumers at retail. Generally, consumers expect meat to have an attractive bright red color, and associate dark meat with increased animal age, lack of freshness, or spoilage. Color detected by the eye is the results of specific attributes including hue, chroma, and value. *Hue* describes the wavelength of light radiation, otherwise known as the presence of a specific color. *Chroma*, also known as purity or saturation and explains color intensity. Finally the *value* or *brightness* refers to the overall light reflectance. Meat color is attributed to the pigments myoglobin (Mb) and hemoglobin, as they absorb certain wavelengths and reflect others. However, the majority of hemoglobin is lost during exsanguination, leaving Mb to constitute 80-90% of total pigment postmortem (Faustman et al., 1996). Mb consists of a globular protein portion and a nonprotein portion called the

heme. The heme group contains a porphyrin ring of iron, which plays an important role in determining meat color. When iron is oxidized (ferric state) it cannot combine with other molecules, such as oxygen, however when iron is reduced (ferrous state) it will readily combine with water or oxygen (Aberle et al., 2001). Therefore, molecular oxygen reacting with reduced iron within Mb would yield desirable red color of fresh meat. Freshly cut meat that is allowed to come into full contact with air allows the reduced pigments to react with oxygen to form a stable pigment called *oxymyoglobin*, giving meat the desirable bright cherry red color. Oxymyoglobin formation takes 30 to 45 minutes after exposure to air, resulting in the bright red color development known as *bloom* (Aberle et al., 2001).

### ***Bison Meat Color***

Bison longissimus muscle color evaluated using Hunter L color parameters revealed that bison muscles were darker than *Bos taurus* (Koch et al., 1995). Koch et al. (1995) also evaluated muscle fiber type of beef and bison and determined that bison had decreased white muscle fibers numbers, and increased intermediate muscle fibers compared to cattle, but did not differ in red muscle fibers. Other studies conducted on the effects of marination (Dhanda et al., 2002), injection enhancement (Pietrasik et al., 2006), low-voltage electrical stimulation (Janz et al., 2001), spray chilling (Janz et al., 2006), and elevated temperature conditioning (Janz et al., 2000) all reported that bison meat undergoes a rapid pigment oxidation and surface discoloration. Pietrasik et al. (2006) reported rapid discoloration, color deterioration, and lipid oxidation in bison compared to beef steaks, indicating there are color stability differences between species.

Joseph et al. (2010) further investigated bison color stability and the primary structure of bison Mb compared to beef by analyzing bison and beef heart muscle. In contrast to previous studies, Joseph et al. (2010) found that bison and beef Mb reacted similarly during different color stability analyses. The molecular mass and primary structure of bison and beef Mb were 100% similar, however bison Mb was different from other ruminants such as water-buffalo, sheep, goat, and red-deer (Joseph et al., 2010). Therefore, the rapid discoloration of bison compared to beef is likely not due to the biochemistry of Mb. Other studies suggest lipid oxidation stimulated by sarcoplasmic extracts (Ramanathan et al., 2009) and the increased PUFA content of bison (Rule et al., 2002) could influence discoloration rate. Lipid oxidation is a major cause of meat discoloration, and may be induced by sarcoplasmic extracts, or caused by variations in the balance of antioxidant-prooxidant components in the sarcoplasm, which is species specific (Ramanathan et al., 2009). While bison meat contains less total fat than beef, it contains increased amounts of PUFAs, which are highly susceptible to oxidation in postmortem muscle compared to saturated fatty acids (Wood et al., 1999).

### ***Tenderness and Evaluation Methods***

A significant amount of meat quality research both historically and presently is focused on meat tenderness. Past studies have determined there are numerous intricate factors that impact tenderness. Antemortem factors such as animal breed, genetics, diet, finishing system, the use of implants, sex, growth rate, muscle location, and animal age at slaughter have all been shown to influence tenderness (Galbraith, 2011). These factors ultimately work through the mechanisms that regulate tenderness including collagen content and solubility, sarcomere length, and proteolytic degradation of the myofibrillar

proteins (Aberle et al., 2001). Tenderness can also be influenced by the use of exogenous enzyme tenderizers, cookery methods, heating temperature, and duration of cooking.

Objective instrumental evaluation of tenderness provides a standardized procedure that can be easily repeated. The most widespread method used in meat quality laboratories is Warner-Bratzler Shear Force (WBSF), which measures the force required to cut through a standard size (1.27 cm) core of cooked meat. In the United States, thresholds have been established to categorize different levels of tenderness perceived by consumers. Utilizing regression analysis of WBSF and trained sensory ratings of overall tenderness, the National Consumer Retail Beef Study reported the threshold value of 4.6 kg was 88.6% accurate at determining whether or not a beef top loin steak would be rated less than “slightly tender” by consumers (Shackelford et al., 1991). Data from another national consumer evaluation for beef tenderness on USDA Select strip loin steaks suggested that WBSF values of < 3.0, 3.4, 4.0, 4.3, and > 4.9 kg would result in 100, 99, 94, 86, and 25% customer satisfaction ratings respectively for beef tenderness (Miller et al., 2002). Additionally, Miller et al. (2002) classified steaks with a WBSF < 3.0 kg as very tender, and steaks >3.0 to 4.6 kg to be intermediate for tenderness, both of which could allow for premium opportunities. Disadvantages of utilizing objective evaluations include the fact that various methods for determining shear force can be used, therefore it is important to account for differences in methods between institutions when comparing WBSF values or consumer thresholds conducted at different labs (Wheeler et al., 1997). Perception of tenderness by humans is difficult to evaluate with scientific instruments alone, as there are several important subjective components. Therefore, objective tenderness evaluations are often supported by consumer or trained sensory panels that can



help account for other sensory components such as softness to tongue and cheek, resistance to tooth pressure, ease of fragmentation, mealiness, adhesion, and residue after chewing (Aberle et al., 2001). Consumer and trained sensory evaluations can be utilized to gauge the intensity of an attribute, determine consumer preference, liking, or attribute a monetary value to the eating experience of a particular piece of meat. The drawbacks of utilizing only data derived from subjective evaluation is repeatability due to the complexity of the processes involved with preparing and assessing a piece of meat (Galbraith 2011).

### Juiciness

Juiciness is an important factor influencing consumer impressions of palatability, as it assists in fragmenting and softening meat during chewing. Melted intramuscular fats and water are the primary contributors to juiciness in meat, as they combine together to form a broth that is released during chewing. Increased marbling enhances juiciness as it melts and becomes distributed along bands of connective tissue during cooking. Uniform distribution of lipids throughout the muscle may also act as a barrier to moisture loss, causing meat to shrink less, resulting in a juicier product after cooking (Aberle et al., 2001).

### *Aroma and Flavor Overview*

Aroma and flavor of meat are important factors responsible for stimulating various responses upon eating meat. Meaty flavor and aroma cause flow of saliva and gastric juices, which aid in digestion (Aberle et al., 2001). Flavor perception results in the recognition of the four basic sensation including salty, sour, sweet, and bitter when

sensed by nerves on the tongue. Aroma recognition occurs when several volatiles are activated by nerves within the nasal passage. The total sensation is a combination of gustatory (taste) and olfactory (smell) stimuli (Aberle et al., 2001). Likely elements influencing flavor and aroma include, certain water-soluble compounds of muscle, connective tissue, and adipose constituents that are volatilized upon heating. Additionally, the breakdown products of ATP, including inosine monophosphate (IMP) and hypoxanthine, can enhance flavor and aroma. These products may explain why frequently used muscles within the carcass have increased flavor and aroma intensities, and the stronger flavors of game animals (Aberle et al., 2001).

### ***Bison Meat Quality Attributes***

Trained sensory panels conducted by Koch et al. (1995) reported that bison loin steaks were more tender compared to those from beef and bison hybrids, however objective shear force values were not significantly different between these species. Trained sensory panels indicated that bison meat had an intense off-flavor compared to beef, and the off-flavors were described as an intense “ammonia, metallic, and gamey flavor” (Koch et al., 1995). A similar trained sensory panel comparing striploin steaks from bison to steaks from *Bos taurus* and *Bos indicus* cattle also reported that bison samples exhibited more off-flavor and aftertaste presence compared to both cattle species (Larick et al., 1989). These off-flavors were described as ammonia, bitter, gamey, liverish, old, rotten, and sour and could be caused by the fatty acid composition of bison; specifically, the increased PUFA content measured in bison compared to both cattle species (Larick et al., 1989). PUFAs can be responsible for the oxidized flavor developed during storage (Igene et al., 1980), or warmed over-flavor in meats (Pearson et al., 1977),

and they are degraded during cooking (Keller & Kinsella, 2006). Additionally, Melton (1983) reported that thermal oxidation of meat with high concentrations of PUFAs could lead to increased incidence and intensity of undesirable flavors.

### ***Vascular Rinse & Chill Solutions***

To investigate methods for improving the darker color of bison meat and evaluate tenderness Mickelson and Claus (2020) investigated the application of a postmortem carcass vascular rinse and chill (RC) system. Infusion of a chilled vascular rinsing solutions is known to aid in the removal of residual blood from carcasses, which generally results in lighter colored meat (Farouk & Price 1994; Dikeman et al., 2003). Bison bulls were either subjected to conventional air chilling or RC in which a catheter was inserted into the carotid artery immediately after exsanguination to allow rinsing of residual blood within the circulatory system using a chilled isotonic substrate solution (Rinse and Chill: 98.5% water; balance: glucose, polyphosphates, and maltose; MPSC Inc., Hudson, WI) at an application rate of 8% of pre-exsanguination carcass weight (Mickelson and Claus 2020). Steaks from the ribeye roll were collected to assess meat quality. Bison ribeye steaks subjected to RC had increased cook loss and decreased WBSF values compared to steaks from conventionally chilled carcasses, however there was no difference in sarcomere length between chilling systems. In contrast Yancy et al. (2002) reported no difference in beef tenderness between conventional and RC systems, and Dikeman et al. (2003) reported RC increased beef toughness. Mickelson and Claus (2020) noted significant movement of unrestrained appendages during application of the RC treatment, which was suggested to stimulate the release of calcium from the sarcoplasmic reticulum early postmortem when pH was still high. This early release of calcium would create a

more favorable environment for calpain activity and could therefore improve tenderness (Koochmaraie et al., 1989). Objective lean color values were collected using a colorimeter, and were recorded over 1, 4, and 7 d postmortem. When averaged across the aging days RC steaks had increased L\* and a\* values, but no differences in b\* values (Mickelson and Claus 2020). A study by Hunt et al. (2003) also reported RC vacuum sealed beef ribeye steaks were lighter in color. The pH recorded at day 7 postmortem did not differ between chilling treatments (Mickelson and Claus 2020). Dikeman et al. (2003) reported that use of a similar vascular infusion on beef did not affect ultimate pH at 24 h, however a more rapid decrease in pH was detected for infused beef. A more rapid pH decline could influence protein functionality if the infused solution was not able to decrease meat temperature fast enough to counter the impact of a lower pH; as low pH and increased temperatures can result in decreased water holding capacity (Mickelson and Claus 2020). Collectively Mickelson and Claus (2020) concluded that RC treatment has the potential to improve tenderness, improve lean color, and increase redness of bison meat products. However, the tenderness mechanisms require further investigation.

## **Harvest Systems**

### ***Animal Stress***

Animals can experience a variety of changes and challenges within their external environment causing them to become excited, fatigued, over-heated, or chilled. These conditions result from reactions within the body in response to external stressors. The term “stress” is a general expression referring to physiological adjustments, such as changes in heart rate, respiration rate, body temperature, or blood pressure that occur

during the exposure of the animal to adverse conditions (Aberle et al., 2001). Several elements of a non-domesticated animal's external environment can cause them to become stressed, such as extreme changes in climate, disease, limited feed or water sources, or predation. Use of best management practices can help to minimize the harmful effects of these environmental elements, but animal handling and transportation can still impose stress. Environmental elements can differ in their effects, as the response that any one environmental condition produces depends on the species, weight, age, sex, inherit stress resistance, and the unpredictable emotional state of the animal (Aberle et al., 2001). Differences in reaction could also be associated with several internal factors. Measurement of blood metabolites, such as acute phase proteins and hormonal concentrations, can be used to evaluate animal health and stress status (Ndou et al., 2011).

### ***Animal Stress Impacts on Meat Quality***

Normal muscle pH ranges from 7.0 to 7.4 and following slaughter and the normal conversion of muscle to meat, drops to a range of 5.3 to 5.8 (Smulders et al., 1992). However, the rate and extent of postmortem muscle pH decline are highly variable and can be influenced antemortem by both acute and chronic stress. Chronic animal stress can be caused by disease, prolonged feed withdrawals, extreme weather, genetics, estrus, disposition, or mixing social groups. These factors can cause animals to deplete glycogen reserves within muscles prior to slaughter, which impedes normal postmortem metabolism and reduces lactic acid production, ultimately creating an abnormal condition known as a "dark cutter" or "dark, firm, dry" (DFD) meat. Characteristics of DFD include an abnormally high pH and increased water binding properties, which create

favorable conditions for bacterial growth, and a decreased ability to reflect light causing a dark external appearance. An acute stress response can be caused by various preslaughter handling processes, including transportation, handling, and feed or water withdrawals (Aberle et al., 2001). Animals undergoing acute stress before slaughter generally have elevated physiological responses such as increased body temperatures and rapid metabolic rates to help adjust homeostasis. These antemortem physiological responses to stress result in depleted ATP stores, causing a shift to anaerobic metabolism and lactic acid accumulation shortly before slaughter. Lactic acid accumulation prior to slaughter causes a rapid postmortem muscle pH decline, coupled with elevated body temperature leads to protein denaturation (Galbraith 2011). Protein denaturation causes a loss of protein solubility, water- and protein-binding capacity, and of intensity muscle color. These meat products are deemed “pale, soft, and exudative (PSE)” (Aberle et al., 2001).

### ***Bison Mobile Slaughter Units***

Bison are large, horned, and non-domesticated animals that can show increased signs of aggression and can become easily excited, as their flight zone tends to be greater than domesticated cattle (Rioja-Lang et al., 2018). The use of on-sight or mobile units are common for slaughtering bison in order to reduce animal handling and transportation, which can ultimately reduce animal stress. Additionally, mobile harvest units provide niche market opportunities for producers as they facilitate placement of low volume/high value livestock products for sale to local markets (Galbraith 2011). Bison can also be harvested using conventional or commercial harvesting systems. Due to limited availability of commercial facilities that can harvest bison, it is common for bison to be transported for several hours, and sometimes kept in pens overnight and harvested the

following day. Gathering, loading, transport, unloading, regrouping, feed and water withdrawal, novel surroundings, and temperature fluctuations are all factors that can create physiological challenges and psychological disruptions that ultimately impact carcass yield and quality (Schaefer et al., 2006).

A series of studies by Galbraith (2011) investigated the animal stress response and meat quality characteristics of bison transported (1.5-3 h), then held overnight with access to water, before they were harvested at a stationary abattoir (LAND), compared to responses of bison harvested using a mobile harvest unit. Bison harvested using a mobile harvest unit were either placed in a pen (approximately 100 x 200 feet) then immobilized (MLAPEN), or confined in a squeeze chute (MLACON) prior to immobilization. Plasma cortisol levels were reported to be lowest in MLAPEN animals. Carcass bruising was present in all animals, but lowest in the mobile harvest treatments. The highest percentage of carcasses identified with “slightly dark to black” lean color was in the LAND treatment, while the MLACON treatment produced more carcasses exhibiting a pale-wet color. These color differences could be attributed to antemortem stress, which can result in a pre-harvest depletion of glycogen, an abnormally high meat pH, and dark lean color (Adegoke and Falade 2005). Generally, a pale-wet color is caused by protein denaturation resulting from a combination of high temperature and low pH (Aalhus et al., 1998). The LAND treatment had increased shear force values and ranked lowest for overall tenderness and palatability by trained sensory panelists (Galbraith, 2011). Overall Galbraith (2011) suggested that bison penned and harvested using a mobile harvest unit (MLAPEN) had superior carcass and meat quality compared to those confined prior to immobilization (MLACON) and those transported to a stationary facility (LAND).

## **Finishing Systems**

### ***Bison Types of Finishing Systems***

Finishing systems can be characterized as collective management practices utilized by livestock producers to generate a finished animal that can be harvested for human consumption. Similar to beef production, bison producers use either intensive (providing animals a grain or concentrate based diet, generally in a feedlot), or extensive (allowing animals to graze pasture or consume a forage-based diet) finishing systems. Utilizing an extensive finishing system could be considered a more traditional management as bison are highly adapted to graze native prairie grasses of the Northern Plains. A series of feeding trials conducted by Koch et al. (1995) reported bison have difficulty adapting to confinement, pen feeding, and consuming moderate to high-concentrate diets, which they defined as “abnormal” for bison. As a result, Koch et al. (1995) concluded that poor growth of bison in the early stages of the feeding trials was due to the time animals required to adapt to pen feeding and consuming a moderate to high concentrate diet. Today it is common for bison producers to utilize a combination of both intensive and extensive finishing systems for bison being raised for meat production.

A review of published literature on the growth, voluntary intake, digestion, and metabolism of bison by Huntington et al., (2019) was undertaken with the intent of creating a source for best management practices in bison. Conclusions of this review expand the earlier work of Koch et al. (1995). Notably studies in this review report bison have reduced dry matter intake resulting in greater dry matter digestion coefficients compared to cattle (Huntington et al., 2019). This review also summarized several feedlot



studies collectively utilizing approximately 1,300 head of bison over the past 43 years. The weighted average of voluntary intake was 2.5% of body weight, and similar levels were also reported for grazing bison (Huntington et al., 2019). Expected average daily gain of bison placed on a feedlot or “farmed” was reported to be greater than or equal to 1.0 kg/d, compared to 0.30 and 0.50 kg/d for grazing or hay fed female and male bison respectively (Huntington et al., 2019). It was concluded that increased gains of the feedlot bison were due to reduced energy utilization for movement coupled with the increased energy content provided in the diets. Regardless of feeding system utilized, results summarized in this review indicate that bison experience a loss in body condition during the colder seasons. This phenomenon is termed the “winter slump” and Huntington et al. (2019) recommends giving consideration to this innate decline in condition when managing bison in a finishing system. However, there is little work evaluating the effects of finishing systems on bison carcass and meat quality traits, therefore beef systems will also be reviewed for context.

### ***Impacts of Beef Finishing Systems on Nutritional Composition and Meat Quality***

It is generally understood that altering animal management and finishing systems can alter the nutritional and quality attributes of meat products. A 2014 review by Van Elswyk and McNeil summarized the reports of several studies comparing grass and grain finishing systems and estimated the impact of diet on the nutrient content of beef, averaged from several different retail cuts. When reported as percent of total fatty acids, SFA were increased in grass-finished beef and decreased in grain-finished beef. However, given that grass-finished beef generally contains less total fat, this percentage does not translate into an increased intake of total SFA in a g/100g serving size, therefore

grain-finished was higher in SFA on a serving size basis. In the same review, MUFA content was increased for grain-finished beef, when calculated both on a total percentage and serving size basis. The PUFA were increased in grain-finished beef on a percent of total fatty basis, but grass-finished beef had increased PUFA on a serving size basis. Cholesterol content did not differ between grass and grain finished beef studies included in the review by Van Elswyk and McNeil (2014), with the exception of a study by Rule et al. (2002) who reported that grass-finished beef had decreased cholesterol levels in steaks from the eye of round, outside round, and mock tenders from the chuck. None of the studies in the review reported differences in protein content caused by feeding systems.

Van Elswyk and McNeil (2014) also summarized the effects of grass-finished and grain-finishing systems on beef quality attributes. Grass-finished beef was reported to be less tender, which was suggested to be the result of lower MUFA content due to the effect of desaturase enzyme activity (Smith et al., 2006). The most abundant MUFA found in beef is oleic acid (18:1, n=9) which has been known to influence greater overall palatability resulting from fat softness that provides a more fluid mouthfeel (Smith and Johnson 2015). Juiciness was reported to be similar between the two systems. Flavor acceptability assessed by United States consumers report that grass-finished beef lacks beef flavor and has more off-flavors present (Van Elswyk and McNeil 2014). Differences in fatty acid profiles, especially the increased PUFA in grass-finished beef, could contribute to flavor differences of beef finished in different systems (Van Elswyk and McNeil 2014). Grass-finished beef is also reported to have increased yellowness of external fat, which is likely related to increased  $\beta$ -carotene deposition within adipose tissue (Duckett et al., 2009 and 2013).

### *Impacts of Bison Finishing Systems on Nutritional Composition*

Marchello and Driskell (2001) and Marchello et al. (1998) compared the nutrient composition of grain-finished (n=100, finished for 180 days prior to slaughter with ad libitum access to hay, and a concentrate ration of various combinations of corn, barley, oats, or wheat middling screens) and grass-finished (n=31, remained on pasture until slaughter) bison bulls. The grass-finished bison were slaughtered at approximately 30 months and grain-finished slaughtered at approximately 25 months of age. Bison were sourced from various regions in the United States and providences in Canada, and were exposed variations in grass- and grain-finishing diets based on different feed source availability and regional vegetation types. Both studies took individual steaks of the ribeye, top sirloin, top round, and the shoulder clod, and averaged the nutrient content values across the four cuts. However, only means were reported in these studies, therefore statistical differences between treatments cannot be distinguished. Grass- and grain-finished bison steaks were reported to have the following compositional values: protein (21.5 and 21.7%), fat (1.7 and 2.2%), moisture (75.9 and 74.6%), and cholesterol content 65 and 66 mg/100g, respectively.

A study conducted by Rule et al. (2002) compared the fatty acid profiles and cholesterol content of steaks (loin, eye of round, and the chuck) from range bison, beef cows, elk cows, and feedlot finished bison and beef steers. Range-fed bison, beef, and elk cows had similar fatty acid composition, specifically the n-3 and n-6 PUFAs. Range-fed cows and bison had greater PUFA content compared to feedlot cattle and bison. Feedlot finished bison and beef shared similar fatty acid profiles, however feedlot cattle had increased total fatty acid concentrations (Rule et al. 2002). Cholesterol content was

lowest in the loin of range-fed bison. Overall the animals used by Rule et al. (2002) were of various ages, species, sex, and fed using different feeds and feeding protocols. Increased age impacts fatty acid profile by decreasing SFA but increasing MUFA in cattle (Rule et al., 1995). Grass or forage feeding regimes generally result in an increase of PUFA and a decreased n-6:n-3 ratio in ruminants (Rule et al., 1995, Cordain et al., 2002). A decreased n-6:n-3 ratio (<4.0) is associated with reduced risk of postprandial inflammation response (increase in circulating triglycerides after food consumption), a symptom that generally results in endothelial (lining of organs and blood vessels) inflammation and dysfunction (Tyldum et al., 2009; Lopez-Garcia et al., 2004; Jarvisalo et al., 2006) or potentially cardiovascular diseases (Hu et al., 2000; Lopez-Garcia et al., 2004; Sinha et al., 2009). Intact males, both rams and bulls, have been found to have increased unsaturated fatty acid content but decreased SFA compared to castrates (Rule et al., 1995, Eichhorn et al., 1985).

Despite the information reported from previous studies, there is still a limited amount of research comparing the effects of different finishing and harvest systems on bison carcass traits, meat quality characteristics, and consumer preference. Additionally, there is no established bison carcass yield or quality grading system in the United States, which limits opportunities to expand markets. Further, bison producers utilize different finishing systems, which also contributes to product variation. Therefore, the objectives of this thesis project were to:

1. Characterize the influence of finishing system (grain-finished vs. grass-finished) on carcass characteristics, meat quality, the nutritional composition, and consumer preference for bison meat.

2. Evaluate the effectiveness of beef camera grading technology on grain- and grass-finished bison carcass characteristics.
3. Characterize the influence of harvest systems (on-ranch vs. commercial facilities) on animal stress response, carcass characteristics, meat quality, and consumer preference of bison heifers.

### **Literature Cited**

- Aalhus, J. L., D. R. Best, A. C. Murray, and S. D. M. Jones. 1998. A Comparison of the quality characteristics of pale, soft and exudative beef and pork. *Journal of muscle foods* 9(3):267-280.
- Aberle, E. D., J.C. Forrest, D. E. Gerrad, E. E. Mills. 2001. *Principles of Meat Science*. Kendall/Hunt, Dubuque, Iowa. 4<sup>th</sup> edition.
- Adegoke, G. O., and K. O. Falade. 2005. Quality of meat. *Journal of Food, Agriculture and Environment* 3(1):87-90.
- Anderson, V. L., and B. Miller. 1997. Influence of season and diet on feedlot performance of Bison. *Professional animal scientist* 13(1):14-17.
- Animal Diversity Web (ADW). *Bison bison*. Accessed 04 June 2019.  
<https://animaldiversity.org/accounts/Bison/classification/>
- Boyd, M. M. 1908. A short account of an experiment in crossing the American Bison with domestic cattle. *American Breeders Association. Annual Report*. 4:324.
- Boyd, M. M. 1914. Crossing bison and cattle. *J. Hered.* 5:189
- Canadian Bison Association (CBA). *Carcass Grading*. (Accessed 07 June 2019).

<https://www.canadianbison.ca/producers/programs-and-services/carcass-grading>

Christopherson, R. J., R. J. Hudson, R.J. Richmond. 1976. Feed intake, metabolism, and thermal insulation of Bison, Yak, and Scottish Highlander, and Hereford calves during winter. University of Alberta Agriculture. Bull., 55<sup>th</sup> Feeders Day Rep. pp-49-52.

Christopherson, R. J., R. J. Hudson, M. K. Christopherson. 1979. Seasonal energy expenditures and thermoregulatory responses of bison and cattle. Can. J. Anim. Sci. 59:611-617.

Cordain, L., B. A. Watkins, G. L. Florant, M. Kelher, L. Rogers, and Y. Li. 2002. Fatty acid analysis of wild ruminant tissues: evolutionary implications for reducing diet-related chronic disease. Eur J Clin Nutr 56(3):181-191. doi: 10.1038/sj.ejcn.1601307

Dhanda, J. S., R. B. Pegg, J. A. Janz, J. L. Aalhus, and P. J. Shand. 2002. Palatability of bison semimembranosus and effects of marination. Meat Sci 62(1):19-26.

Dietary Guidelines Advisory Committee (2010). Report of the Dietary Guidelines Advisory Committee on the Dietary Guidelines for Americans. Accessed 23 May, 2020. [https://centerforinquiry.org/wp-content/uploads/sites/33/quackwatch/dga\\_advisory\\_2010.pdf](https://centerforinquiry.org/wp-content/uploads/sites/33/quackwatch/dga_advisory_2010.pdf)

Dikeman, M. E., M. C. Hunt, P. B. Addis, H. J. Schoenbeck, M. Pullen, E. Katsanidis, and E. J. Yancey. 2003. Effects of postexsanguination vascular infusion of cattle with a solution of saccharides, sodium chloride, and phosphates or with calcium chloride on quality and sensory traits of steaks and ground beef<sup>1,2</sup>. Journal of Animal Science 81(1):156-166.

Duckett, S.K., J. P. S., Neel, J. P., Fontenot, W.M. Clapham, 2009.

Effects of winter stocker growth rate and finishing system on: III. Tissue proximate, fatty acid, vitamin and cholesterol content. *Journal of Animal Science*, 87, 2961-2970.

Duckett, S.K., J. P. S., Neel, R. M., Lewis, J. P., Fontenot, W.M. Clapham. 2013.

Effects of forage species or concentrate finishing on animal performance, carcass, and meat quality. *Journal of Animal Science*, 91, 1454-1467.

Eichhorn, J. M., C. M. Bailey, and G. J. Blomquist. 1985. Fatty acid composition of muscle and adipose tissue from crossbred bulls and steers. *J Anim Sci* 61(4):892-904.

Farouk, M. M., and J. F. Price. 1994. The effect of post-exsanguination infusion on the composition, exudation, color and post-mortem metabolic changes in lamb. *Meat Science* 38(3):477-496.

Faustman, C., W.K. M. Chan, M.P. Lynch, S.T. Joo. 1996. Strategies for increasing oxidative stability of fresh meat colour. *Reciprocal Meat Conference* 49: 73-78.

Galbraith J.K. 2011. Meat characteristics and stress of bison slaughtered in a mobile or stationary abattoir. Ph.D. dissertation. University of Alberta, Edmonton, Alberta.

Galbraith, J., A. Rodas-Gonzalez, O. Lopez-Campos, M. Juarez., J Aalhus. 2014.

Bison Meat: Characteristics, challenges, and opportunities. *Animal Frontiers* 4(4):68-73.

Goodnight, C. 1914. My experience with bison hybrids. *J. Hered.* 5:197.

Hawley, A.W.L. 1986. Carcass Characteristics of bison (*Bison bison*) steers. *Canadian Journal of Animal Science*. 66:293.

- Hudson R. J., and J. C Haigh JC. 2002. Physical and physiological adaptations. In: North American elk: ecology and management. D.E. Toweill DE and J. W. Thomas, ed. Smithsonian Inst. Press, Washington D.C., USA, pp 199-257
- Huntington, G. B., M. Woodbury, V. Anderson. 2019. Invited Review: Growth, voluntary intake, and digestion and metabolism of North American bison. *Applied Animal Science*, Volume 35, Issue 2, 146 – 160.
- Hunt, M. C., J. J. Schoenbeck, E. J. Yancey, M. E. Dikeman, T. M. Loughin, and P. B. Addis. 2003. Effects of postexsanguination vascular infusion of carcasses with calcium chloride or a solution of saccharides, sodium chloride, and phosphates on beef display-color stability<sup>1</sup>. *Journal of Animal Science* 81(3):669-675.
- Hu, F. B., E. B. Rimm, M. J. Stampfer, A. Ascherio, D. Spiegelman, and W. C. Willett. 2000. Prospective study of major dietary patterns and risk of coronary heart disease in men. *Am J Clin Nutr* 72(4):912-921.
- Igene, J. O., A. M. Pearson, L. R. Dugan, and J. F. Price. 1980. Role of triglycerides and phospholipids on development of rancidity in model meat systems during frozen storage. *Food Chemistry* 5(4):263-276.
- Institute of Medicine. 2005. Dietary reference intakes for energy, carbohydrates, fiber, fat, fatty acids, cholesterol, protein, and amino acids. Washington DC: National Academic Press.
- Janz, J. A. M., J. L. Aalhus, M. A. Price, and A. L. Schaefer. 2000. The influence of elevated temperature conditioning on bison (*Bison bison bison*) meat quality. *Meat Science* 56(3):279-284
- Janz, J. A. M., J. L. Aalhus, and M. A. Price. 2001. Blast chilling and low voltage



- electrical stimulation influences on bison (*Bison bison bison*) meat quality. *Meat Science* 57(4):403-411.
- Janz, J. A. M., and J. L. Aalhus. 2006. Meat quality, bacteriology and retail case life of bison longissimus lumborum following spray chilling. *Journal of Muscle Foods* 17(3):330-342.
- Järvisalo, M. J., M. Juonala, and O. T. Raitakari. 2006. Assessment of inflammatory markers and endothelial function. *Curr Opin Clin Nutr Metab Care* 9(5):547-552.
- Jesmer, B., J. Goheen, K. Monteith, and M. Kauffman. 2017. State-dependent behavior alters endocrine-energy relationship: Implications for conservation and management. *Ecological Applications* 27doi: 10.1002/eap.1608
- Jones, C. J. 1907. Breeding catalo. American Breeders Association. Annual Report 3:161.
- Joseph, P., S. P. Suman, S. Li, C. M. Beach, L. Steinke, and M. Fontaine. 2010. Characterization of bison (*Bison bison*) myoglobin. *Meat Science* 84(1):71-78.
- Keller, J., and J. Kinsella. 2006. Phospholipid changes and lipid oxidation during cooking and frozen storage of ground beef. *Journal of Food Science* 38:1200-1204.
- Koch. R. M., H.G. Jung, J. D. Crouse, V. H. Varel, & L. V. Cundiff. 1995. Growth, digestive capability, carcass, and meat characteristics of *Bison bison*, *Bos taurus*, and *Bos x Bison*. *Journal of Animal Science*. 73, 1271-1281.
- Koohmaraie, M., J. Crouse, and H. Mersmann. 1989. Acceleration of Postmortem Tenderization in Ovine Carcasses Through Infusion of Calcium Chloride: Effect of Concentration and Ionic Strength. *Journal of Animal Science*.
- Larick, D., B. Turner, R. Koch, and J. Crouse. 1989. Influence of phospholipid content

- and fatty acid composition of individual phospholipids in muscle from bison, hereford and brahman steers on flavor. *Journal of Food Science* 54:521-526.
- Logan, V.S., P. E. Sylvestre. 1950. Hybridization of domestic beef cattle and buffalo. Progress Report. 1937-1949, Animal Husbandry Division., Can. Dept. Agric.
- Lopez-Garcia, E., M. B. Schulze, T. T. Fung, J. B. Meigs, N. Rifai, J. E. Manson, and F. B. Hu. 2004. Major dietary patterns are related to plasma concentrations of markers of inflammation and endothelial dysfunction. *Am J Clin Nutr* 80(4):1029-1035.
- Marchello, M.J., J.A., Driskell. 2001. Nutrient composition of grass- and grain-finished bison. *Great Plains Research*. 11:65-82
- Marchello, M.J., W.D. Slinger, M. Hadley, D.B Milne, J.A. Driskell. (1998). Nutrient composition of bison fed concentrate diets. *Journal of Food Composition and Analysis*. 11:231:39.
- Marchello, M. J., W. D. Slinger, D. B. Milne, A. G. Fischer, and P. T. Berg. 1989. Nutrient composition of raw and cooked Bison bison. *Journal of Food Composition and Analysis* 2(2):177-185.
- Melton, S. L., M. Amiri, G. W. Davis, and W. R. Backus. 1982. Flavor and Chemical Characteristics of Ground Beef from Grass-, Forage-Grain- and Grain-Finished Steers. *Journal of Animal Science* 55(1):77-87.
- Mickelson, M. A., and J. R. Claus. 2020. Carcass chilling method effects on color and tenderness of bison meat. *Meat Science* 161:108002.
- Miller, M., M. Carr, C. Ramsey, K. Crockett, and L. Hoover. 2002. Consumer thresholds

for establishing the value of beef tenderness. *Journal of animal science* 79:3062-3068.

National Bison Association (NBA). 2019. Current Status. Accessed 05 June, 2019

<https://bisoncentral.com/current-status/>

National Bison Association (NBA). 2019. Code of Ethics. Accessed 18 June, 2019

<https://bisoncentral.com/national-bison-association-code-of-ethics/>

National Bison Association (NBA). 2019. Bullish on Bison. Accessed 23 May, 2020

<https://bisoncentral.com/wp-content/uploads/2019/07/Bullish-on-Bison-7-19.pdf>

National Bison Association (NBA). 2020. Current Status. Accessed 24 July, 2020

<https://bisoncentral.com/current-status/>

Ndou, S., V. Muchenje, and M. Chimonyo. 2011. Animal welfare in multipurpose cattle production Systems and its implications on beef quality. *African Journal of Biotechnology* 10:1049-1064.

Parker, K., P. Barboza, and M. Gillingham. 2009. Nutrition integrates environmental responses of Ungulates. *Functional Ecology* 23:57-69.

Pearson, A. M., J. D. Love, and F. B. Shorland. 1977. Warmed-Over" Flavor in Meat, Poultry, and Fish. In: C. O. Chichester, E. M. Mrak and G. F. Stewart, editors, *Advances in Food Research* No. 23. Academic Press. p. 1-74.

Peters, H. F. 1958. A feedlot study of bison, cattlo and Hereford calves. *Canadian Journal of Animal Science*. 38:87.

Pietrasik, Z., J. Dhanda, P. Shand, and R. Pegg. 2006. Influence of Injection, Packaging, and Storage Conditions on the Quality of Beef and Bison Steaks. *Journal of Food Science* 71:S110-S118.

- Ramanathan, R., M. K. Konda, R. A. Mancini, and C. Faustman. 2009. Species-specific effects of sarcoplasmic extracts on lipid oxidation in vitro. *J Food Sci* 74(1):C73-77.
- Rioja-Lang, F. C., J. K. Galbraith, R. B. McCorkell, J. M. Spooner, and J. S. Church. 2019. Review of priority welfare issues of commercially raised bison in North America. *Applied Animal Behaviour Science* 210:1-8.
- Rule, D. C., S. B. Smith and J. R. Romans. 1995. Fatty acid composition of muscle and adipose tissue of meat animals. In: *The biology of fat in meat animals-Current advances* (Ed. S. B. Smith and D. R. Smith). The American Society of Animal Science, Champaign, Illinois. pp. 144-165.
- Rule, D.C., K.S. Broughton, S.M. Shellito, and G. Mariorano. 2002. Comparison of muscle fatty acid profiles and cholesterol concentrations of bison, beef, elk, and chicken. *Journal of Animal Science*, 80, 1202-1211.
- Rutley, B. D., and R. J. Hudson. 2001. Activity budgets and foraging behavior of bison on seeded pastures. *Journal of Range Management* 54:218-225.
- Schaefer, A. L., R. W. Stanley, A. K. W. Tong, P. Dubeski, B. Robinson, J. L. Aalhus, and W.M. Robertson. 2006. The impact of antemortem nutrition in beef cattle on carcass yield and quality grade. *Canadian Journal of Animal Science* 86:317-323.
- Scollen, N., J.P. Hocquette, K. Nuernberg, D. Danneberger, L. Richardson, and A. Molony. 2006. Innovations in beef production systems that enhance the nutritional and health value of beef lipids and their relationship with meat quality. *Meat Science*, 74, 17-33.
- Sinha, R., A. J. Cross, B. I. Graubard, M. F. Leitzmann, and A. Schatzkin. 2009. Meat

- intake and mortality: a prospective study of over half a million people. *Arch Intern Med* 169(6):562-571. doi: 10.1001/archinternmed.2009.6.
- Shackelford, S. D., J. B. Morgan, H. R. Cross, and J. W. Savell. 1991. Identification of threshold levels for warner-bratzler shear force in beef top loin steaks. *Journal of Muscle Foods* 2(4):289-296.
- Smith, S. B., d. K. Lunt, K. Y. Chung, C. B. Choi, R. K. Tume, M. Zembayashi. 2006. Adiposity, fatty acid composition, and delta-9 desaturase activity during growth in beef cattle. *Animal Science Journal* 77(5):478-486.
- Smith, S.B., B.J. Johnson. (2015). Marbling: Management of cattle to maximize the deposition of intramuscular adipose tissue. 10.13140/RG.2.1.1713.3525.
- Smulders, F.J.M., F. Toldra, J. Flores, M. Prieto. 1992. New technologies for meat and meat products. Pp 182, 186-188. Utrecht, The Netherlands: Audet Tiidschriften.
- Spronk, J.L., D.M. Wulf, B.W. Anderson, A.C. Kulowski, B.A. Streff, A.M. Gensmer, R.J. Maddock. Undated. Estimates of Meat Product Yields from Bison Carcasses. South Dakota State Univeristy; Meat Science.
- Tyldum, G. A., I. E. Schjerve, A. E. Tjønnå, I. Kirkeby-Garstad, T. O. Stølen, R. S. Richardson, and U. Wisløff. 2009. Endothelial dysfunction induced by post-prandial lipemia: complete protection afforded by high-intensity aerobic interval exercise. *J Am Coll Cardiol* 53(2):200-206.
- Van Elswyk, M.E., S.H. McNeil. 2014. Impact of grass/forage feeding versus grain finishing on beef nutrients and sensory quality: The U.S. experience. *Journal of Meat Science*. 96: 535-540.
- Wheeler, T. L., S. D. Shackelford, L. P. Johnson, M. F. Miller, R. K. Miller, and M.

Koohmaraie. 1997. A comparison of Warner-Bratzler shear force assessment within and among institutions. *J Anim Sci* 75(9):2423-2432.

Wood, J. D., M. Enser, A. V. Fisher, G. R. Nute, R. I. Richardson, and P. R. Sheard. 1999. Manipulating meat quality and composition. *Proceedings of the Nutrition Society* 58(2):363-370.

Yancey, E., M. E. Dikeman, P. Addist, E. Katsanidis, and M. Pullen. 2002. Effects of vascular infusion with a solution of saccharides; sodium chloride; phosphates; and vitamins C, E, or both on carcass traits, Warner-Bratzler shear force, and palatability traits of steaks and ground beef. *Journal of animal science* 80:1904-1910.

CHAPTER 2: CARCASS CHARACTERISTICS, MEAT QUALITY,  
NUTRITIONAL COMPOSITION, AND CONSUMER PREFERENCE OF GRAIN  
AND GRASS FINISHED BISON HEIFERS

**Abstract**

This study aimed to evaluate the influence of finishing system (grain- or grass-finishing) on: 1) carcass characteristics and meat quality of bison heifers, and 2) consumer preference for bison steaks. Bison heifers were randomly assigned to treatments: Grain-finished (n=108, backgrounded on pasture and finished in a drylot for 130 d with ad libitum access to hay and a corn and dry distiller's grain diet) or Grass-finished (n=93, remained on pasture until slaughter). Heifers were slaughtered at 28 mo of age. Carcass measurements were recorded, and striploins were collected from a subsample of carcasses (n=30 carcasses closest to the treatment average hot carcass weight). Ultimate pH was recorded, and striploins were fabricated into 2.54-cm steaks. One steak was designated for analysis of fatty acid profile, cholesterol content, and proximate analysis. Two steaks were aged for 14 d for consumer sensory evaluation; 4 additional steaks were aged for 4, 7, 14, or 21 d for analysis of Warner-Bratzler shear force (WBSF) and cook loss. All data were analyzed using the MIXED procedure of SAS. Carcass and meat quality data were analyzed for the main effect of finishing treatment, with slaughter date as a random effect. Cook loss and WBSF were analyzed as repeated measures using the ante-dependence covariance structure for effects of finishing treatment, aging, and their interaction, with peak temperature as a covariate. Consumer preference was analyzed for the main effects of finishing treatment and serving order; serving time and panelist were included as random effects. Separation of least-squares

means was performed using LSD with a Tukey's adjustment, assuming  $\alpha = 0.05$ . Grain-finished bison heifers had greater ( $P < .01$ ) live and hot carcass weights, dressing percentage, ribeye area, back fat, and marbling scores compared to grass-finished heifers. Instrumental color values ( $L^*$ ,  $a^*$ ,  $b^*$ ) of the ribeye and  $a^*$  value of back fat opposite the ribeye were increased ( $P < .01$ ) for grain-finished heifers. However,  $L^*$  and  $b^*$  values of back fat opposite the ribeye were decreased ( $P < .01$ ) in carcasses from the grain-finished system. Steaks from grain-finished heifers had increased ( $P < .05$ ) crude protein and fat content and decreased ( $P < .01$ ) moisture, while percentage of ash did not differ ( $P > .10$ ) between treatments. The grain-finishing system produced steaks with increased ( $P < .01$ ) cholesterol, palmitic, stearic, oleic, linoleic, arachidonic, and total fatty acids (mg/g of wet tissue). However, when expressed as a percentage of total lipid, grass-finished samples had increased ( $P < .05$ ) proportion of PUFA and SFA. The grain-finished system produced more tender ( $P < .05$ ) steaks than grass-finished. Tenderness of all steaks improved ( $P < .01$ ) with postmortem aging. Cook loss was affected ( $P < .05$ ) by the interaction of treatment with aging period. Overall cook loss was reduced ( $P < .01$ ) for grain-finished and increased ( $P < .05$ ) in steaks aged 4 d compared with 7 d or 21 d. Additionally bison steaks kept in frozen storage conditions had improved tenderness ( $P < .0001$ ) but increased ( $P = .0001$ ) cook loss compared to bison steaks kept in fresh storage conditions. Finishing system did not influence ( $P > 0.10$ ) ultimate pH or sensory ratings by the consumer panel. Collectively these data indicate that finishing systems influence bison carcass characteristics and meat quality; however, these do not translate to changes in consumer preferences. Additionally, finishing system influenced nutrient content and fatty acid composition, which may have health implications.



## Introduction

Bison (*bison bison*) were hunted to near extinction in North America during the late 1800's (Marchello and Driskell, 2001). However, numbers have rebounded and production and consumption of bison has increased significantly in the past 15 years. (National Bison Association, 2018). Currently it is estimated that there are approximately 400,000 bison in North America (including private, state, federal, and tribal herds; National Bison Association: Current Status, 2020). Previous research has reported bison meat to be leaner and has elevated polyunsaturated fatty acid (PUFA) content compared to cattle when both species are reared similarly (Koch et al., 1995, Marchello et al., 1989, Larick et al., 1989), thus potentially enhancing the perception that consuming bison meat maybe be healthier than consuming beef (Rule et al., 2002). Despite increasing popularity, quality attributes such as tenderness, juiciness, and flavor consumers prefer in bison meat are not well understood, which limits opportunities to expand markets. Further, producers utilize different finishing systems, which lends to product variation.

Results from previous beef studies have generally concluded that forage finishing results in leaner carcasses compared with grain finishing when cattle are harvested at similar ages (Duckett et a., 2007, 2009, Neel et al., 2007). Several beef studies have also shown that finishing systems impact meat quality (Reagan et al., 1977; Bidner et al., 1981, 1986; McIntyre and Ryan, 1984; Morris et al., 1997; Maughan et al., 2012), as the nutrient composition of the feed and amount of dietary energy available to the animal can modify beef carcass composition (Muier et al., 1998), including the amount of intramuscular fat (IMF) and the fatty acid profile. Changes in IMF and fatty acid profile are known to influence the eating quality and flavor of beef (Mills et al., 1992; French et al., 2000, 2001;

Melton 1990; Tansawat et al., 2013). Grain-finished beef is considered to have more acceptable flavor compared with forage-finished beef (Larick et al., 1987; Medeiros et al., 1987 French et al., 2001; O'Quinn et al., 2016). Changes in fatty acid profile can also impact nutritional quality, as food products containing greater ratios ( $>0.45$ ) of polyunsaturated fatty acids (PUFA) to saturated fatty acids (SFA) and lower ratios of n-6:n-3 ( $<4.0$ ) may reduce the incidence of coronary artery disease (Simopoulos, 2004). Forage-finished beef has been found to have increased PUFA:SFA ratios (Enser et al., 1998; Elmore et al., 2004).

Currently there is limited research on the carcass characteristics produced across the bison industry, or the effects of common finishing systems on product outcomes. Therefore, the objective of this study is to characterize the influence of finishing system (grain-finished or grass-finished) on carcass characteristics, meat quality, nutritional composition, and consumer preference for bison meat.

## **Materials and Methods**

### ***Animals, Carcass Evaluation, and Striploin Collection***

Bison heifers (20 mo of age) from several source ranches of the same operation were transported to a finishing ranch near Fort Pierre, SD and randomly assigned to 2 finishing treatments: Grain- (n = 108) and Grass- (n = 93) finished. Grass-finished heifers were allowed to graze pasture until harvest. Grain-finished heifers were allowed to graze pasture (common vegetation includes: Western wheatgrass, Blue grama, Needle and thread, and Green needlegrass) until the initiation of the grain finishing phase. At 130 days prior to slaughter, grain-finished heifers were placed in a single 100,000 square foot open

lot pen (~1,000 square foot per animal) and provided ad libitum access to prairie grass and alfalfa hay bales placed in hay rings, as well as a concentrate mixture (83% corn, 17% dried distillers grain) placed in feed bunks. Both finishing treatments had access to a custom loose mineral and vitamin supplement [Custom Mineral Mix: Product Code Numbers: 602713 and 603652 (Included Rabon for fly control May-October, 2018) Furst-McNess, Freeport Illinois]. Heifers in the grain-finished treatment had access to automatic waters, while heifers in the grass-finished treatment had access to stock ponds and rural water provided in stock tanks. At 28 mo of age all heifers were transported (~720 km) to a commercial harvest facility, and harvested over a two-day period. On the first day of slaughter, 47 head of grass-finished heifers and 54 head of grain-finished were slaughtered. On the second day of slaughter, 46 head of grass-finished and 54 head of grain-finished were slaughtered. After an approximately 20 h chilling period carcasses were ribbed between the 12<sup>th</sup> and 13<sup>th</sup> rib and, ribeye area, back fat thickness, and marbling score, skeletal maturity, lean maturity, and external fat color were determined by USDA graders. Skeletal maturity was subjectively scored based on the ossification percentage of the thoracic cartilage buttons, and assigned a number (11, 7, 5, and -5) that corresponded with ossification percentages as follows: 0-24% (slight, 11), 25-49% (moderate, 7), 50-99% (hardbone, 5), and 100-200 (extreme hardbone, -5). Lean maturity was subjectively scored based on the lean color of the exposed ribeye, and assigned a number (11, 7, 5, 3, 1, or 0) corresponding to a color description as follows: bright red (11), moderately bright red (7), slightly bright red (5), red (3), pale red (1), and dark cutter (0). Fat color was subjectively scored based on the external fat color, and assigned a number (11, 7, 5, 3, 1) that corresponded to fat color as follows: white (11), moderately white (7), slightly white (5),

moderately yellow (3), and yellow (1). Additionally, objective color ( $L^*$ ,  $a^*$ ,  $b^*$ ) of the exposed ribeye area and the subcutaneous fat on the carcass surface opposite the ribeye were recorded using a handheld Minolta colorimeter (Model CR-310, Minolta Corp., Ramsey, NJ; 50 mm diameter measuring space;  $D_{65}$  illuminant). A subsample ( $n = 60$ ; 30 carcasses closest to the average hot carcass weight (HCW) for each harvest date per treatment) was selected and transported to a commercial processing facility. Striploins were removed from one side of each carcass, vacuum packaged, and transported back the South Dakota State University Meat Laboratory.

### ***Striploin Fabrication and pH***

Striploin sample arrived at the South Dakota State University meat laboratory at 2 and 3 days postmortem. Upon arrival all striploins were removed from vacuum packages and trimmed of external fat. Ultimate pH was recorded at the posterior end of the striploin using a hand-held pH meter (Thermo-Scientific Orion Star, Beverly, MA, Model# A221 and Star A321 Portable pH Probe). An approximately 1.27 cm slice was removed from the anterior face of each striploin. The remaining striploin was fabricated into 2.54-cm steaks, all of which were individually vacuum packaged and assigned for analysis. One steak was designated for proximate analysis, analysis of cholesterol content, and fatty acid profile and was frozen immediately. Five steaks were designated for Warner-Bratzler shear force (WBSF). One steak was stored for 14 d at 4°C and sheared without freezing (fresh). Four additional steaks were assigned to a 4, 7, 14, or 21 d aging period, then frozen for approximately 3 months prior to shear force analysis. Fourteen day aged fresh and frozen

samples were utilized to compare the influence of freezing on bison steak tenderness. Two steaks designated for a consumer sensory panel were aged for 14 d and frozen.

### ***Proximate Analysis***

To determine proximate nutrient composition of the *longissimus dorsi* muscle samples were thawed slightly and trimmed of excess external fat and accessory muscles, chopped, submerged in liquid nitrogen, and powdered using a stainless-steel blender (Waring Products Division, Model# 51BL32, Landcaster, PA). Homogenized samples were stored at -20 °C in plastic bags (Whirlpack, Nasco, Fort Atkinson, WI) until used for chemical composition analyses. Percent crude fat and moisture were determined using the ether extract method outlined by Mohrhauser et al. (2015). Powdered samples were weighed (~5 g,) into dried aluminum tins (FisherBrand, Pittsburgh, PA, Cat.# 08-732-101), covered with dried filter papers (Whatman, Buckinghamshire, UK, Cat.# 1001-1055) and dried in an oven (Precision Scientific, Winchester, VA, Cat.# 51220159) at 101 °C for 24 h. Dried samples were then placed into a desiccator (Scienceware, Wayne, NJ, Cat.# 420320000) and samples were reweighed after cooling for at least 1 h. Proximate moisture content was calculated as the difference between pre- and post-drying sample weights and expressed as percent of the pre-drying sample weight. Dried samples were then extracted with petroleum ether in a side-arm Soxhlet extractor (ThermoFischer Scientific, Rockville, MD) for a 60 h reflux period followed by evaporation under the laboratory hood at room temperature for 4 h and subsequent drying in an oven at 101 °C for 4 h (Bruns et al., 2004). Dried, extracted samples were placed in desiccators to cool for 1 h and then reweighed. Proximate intramuscular fat content was

calculated as the difference between pre- and post-extraction sample weight and expressed as a percent of the pre-extraction sample weight.

To determine ash percentage of each sample, duplicate powdered samples were weighed (~3 g) into dried ceramic crucibles (COORSTEK, Golden, CO, Cat. #60109) and placed into an oven at 101 °C for 24 h. Dried samples were then placed into a glass desiccator and samples were reweighed after cooling for at least 1 h, then placed into a muffle furnace (Fisher Scientific Co., Pittsburgh, PA, Model Series# 10-650) at 500°C and ashed for 24 h. Ashed samples were removed and placed into a desiccator once the furnace cooled down to approximately 150°C. Ashed samples were cooled in the desiccator for at least 1 h then reweighed. Proximate ash content was calculated as the difference between pre- and post ashed sample weights and expressed as percent of the pre-ashed sample weight.

To determine protein content, duplicate powdered samples were weighed (~250 mg) into crucibles and were subjected to dumas combustion by a nitrogen analyzer (Rapid Max N Exceed, Elementar, Hanau, Germany, Serial# 29161032). Percent protein content was determined based on the protein factor (6.25) multiplied by the percent nitrogen detected for each sample.

### ***Cholesterol Determination***

To determine cholesterol content of the *longissimus dorsi* muscle samples were thawed slightly and trimmed of excess external fat and accessory muscles, chopped, submerged in liquid nitrogen, and powdered using a stainless-steel blender (Waring Products Division, Model# 51BL32, Landcaster, PA). Homogenized samples were held

at -80 °C in plastic bags (Whirlpack, Nasco, Fort Atkinson, WI) until used for cholesterol determination.

The AOAC Official Method 994.10, Cholesterol in Foods, Direct Saponification-Gas Chromatographic Method (First Action 1994) was used with modifications described by Dinh et, al (2008). Cholesterol standards were prepared at concentrations of 0.0125, 0.025, 0.05, and 0.1 mg/mL to construct a standard curve for cholesterol determination. An internal standard, 5 $\alpha$ -cholestane (ACROS Organics, NJ, USA, Cat.# AC165602500), was used as a correction factor to standardize injection errors. All standards were diluted in high-grade toluene (ACROS Organics, NJ, USA, Lot# B052366, UN1294), and were subjected to the Gas chromatographic system (GC) analysis before and after sequential sample analysis to obtain an average curve. Frozen steak samples were accurately weighed to 1.000 (to the nearest 0.001 g), recorded, and placed into 125-mL flat-bottom boiling flasks, followed by the addition of 2 mL of 50% potassium hydroxide (KOH) in water and 10 mL of 95% ethanol. Flasks were placed onto heated magnetic stir plates (Huanghua Faithful Instrument Co., Ltd, Huanghua City, Heibei Province, China, Ser.# 201709183624). The mixtures were boiled, stirred, and refluxed for at least 25 min, or until mixture was clear. Flasks were removed from the stir plates and allowed to cool to room temperature (~25°C). Mixed solutions were transferred from the boiling flasks to separatory funnels, followed by the addition of 10 mL high-grade toluene and 1.0 N aqueous KOH. Funnels were shaken vigorously for at least 10-s. Mixtures were allowed to stand until the toluene layer was distinctly separated from the bottom aqueous layer. The bottom aqueous layer was discarded, and 5 mL of 0.5 N aqueous KOH was added, gently mixed, and allowed to stand until a clear separation of layers occurred. The bottom

aqueous layer was again discarded. The remaining toluene layer was purified by four washes of 5 mL of deionized water. After each wash of deionized water, the solution was mixed, and let stand for complete separation of layers, which allowed the bottom aqueous layer to be discarded before the next wash. The final toluene layer, which could be cloudy, was poured into a 50-mL test tube containing approximately 3 g of anhydrous sodium sulfate. Test tubes were shaken for approximately 5-sec to remove excess moisture associated with the toluene. The mixture was allowed to stand until a visibly clear toluene solution appeared, with the anhydrous remaining as a white gelatinous bottom layer. Additional anhydrous was added if the final toluene layer remained cloudy after shaking and allowed to settle. The final purified extract was stored in test tubes with teflon-lined caps under refrigeration. Prior to mixing, all solutions were brought to room temperature. In a 2.0 mL GC vial (Agilent Technologies, Santa Clara, CA, Part No., 5188-6592, Batch No., GTG023112229), 0.5 mL of the clear toluene solution containing the extracted cholesterol was mixed with 0.5 mL of internal standard and subjected to GC analysis.

Liberated cholesterol was quantified using the Agilent 6890N gas chromatographic system and the DB-17 capillary column (30 m × 0.250 mm × 0.15µm, Agilent Technologies Inc., Santa Clara, CA). The DB-17 has mid-polarity and is suitable for analysis of free steroids. One microliter (1.0 µL) of analyte cholesterol mixture was injected into the GC system with split /splitless injector and flame ionization detector. The inlet temperature was 250°C and split ratio was 50:1. The carrier gas was helium at 1.4 mL/min constant flow. The oven was programmed isothermally at 260 °C and held for 13 min. Total time for gas chromatographic determination was 15 min. The detector



was set at 350 °C with 450 mL/min airflow, 40 mL/min hydrogen flow, and 40 mL/min constant column and helium makeup flow.

### ***Fatty Acid Composition Analysis***

To determine fatty acid methyl ester (FAME) analyses of the *longissimus dorsi* muscle samples were thawed slightly and trimmed of excess external fat and accessory muscles, chopped, submerged in liquid nitrogen, and powdered using a stainless-steel blender (Waring Products Division, Model# 51BL32, Landcaster, PA). Homogenized samples were held at approximately -80 °C in plastic bags (Whirlpack, Nasco, Fort Atkinson, WI) until later used for (FAME) analyses. Frozen samples were accurately weighed to 1.000 (to the nearest 0.001 g) and processed to generate FAME according to procedures outlined by Legako, 2019.

Analysis of FAME was conducted by GC using an HP-88 capillary column (30m × 0.25 mm × 0.20 µm; Agilent Technologies, Palo Alto, CA, USA) and a flame ionization detector (FID). One microliter of sample was injected with a split ratio of 50:1. The oven method was as follows: 120°C held for 1 min, increased to a temperature of 170 °C at the rate of 15°C/min, held for 2 min, then increased to a temperature of 200°C at the rate of 3°C/min, held for 1 min, and finally increased to a temperature of 235°C at a rate of 20°C/min and held for 1 min. Hydrogen was used as the carrier gas. The FID was operated at 300°C. Fatty acid methyl esters were identified and quantified by use of authentic standards (Supelco 37 Component FAME mix, Sigma-Aldrich, St. Louis, MO, USA). Concentrations of fatty acids were calculated and expressed on both a raw wet-weight, and percentage of total fatty acid basis.

### ***Warner-Bratzler Shear Force and Cook Loss***

Warner-Bratzler Shear Force was utilized to compare the tenderness of grass- and grain-finished bison, the influence of postmortem aging on tenderness of striploin steaks from grain- and grass-finished bison, and the influence of storage conditions (fresh versus frozen) on tenderness of bison striploin steaks. In preparation for WBSF, frozen steaks were thawed for 24 h at 4°C before cooking. All steaks were weighed prior to cooking to an internal temperature of 71°C. Steaks were cooked on an electric clamshell grill (George Forman 9 Serving Classic Plate Grill, Model GR2144P, Middleton, WI). Internal temperature was monitored using a digital thermometer (Cooper-Atkins, Middlefield, CT, Model# 41-983430-5) placed near the geometric center of each steak. After cooking, all steaks were allowed to cool to room temperature before they were reweighed to determine cook loss; reported as a percentage of the raw weight using the following equation:  $[(\text{raw weight} - \text{cooked weight})/\text{raw weight}] \times 100$ . Cooked steaks were cooled for 24 h at 4°C before removing 5 to 6 cores (1.27 cm in diameter) parallel to the muscle fiber orientation and sheared once perpendicular to the muscle fiber orientation and peak force was recorded (AMSA, 2015). A texture analyzer (Shimadzu Scientific Instruments Inc., Lenexa, KS, Model# 30825535050) with a Warner-Bratzler attachment was used to determine peak force required to shear each core. An average shear peak force value was then reported for each steak.

### ***Consumer Preference***

A consumer sensory panel was conducted at the University of Minnesota sensory laboratory to determine subjective meat quality characteristics of grain- and grass-finished bison striploin steaks. Random participants (n = 113) were recruited from the student and staff population of the University of Minnesota and included anyone who expressed an interest in participating in sensory tests. Participants were 18 years or older, had no food allergies or sensitivities, were willing to consume bison meat, and must have consumed any type of meat at least once a year. Participants were compensated \$10.00 for their time. The University of Minnesota's Institutional Review Board (IRB) approved all recruiting and experimental procedures (IRB #6792). Sample steaks, aged 14 d and kept in frozen storage conditions (~10 m) prior to analysis, were wrapped in aluminum foil, and allowed to thaw for 48 h before they were placed in an electric oven set to 204 °C. Internal temperature was monitored using a digital thermometer (Cooper-Atkins, Middlefield, CT, Model# DTT361 - 01) placed near the geometric center of each steak. Steaks were cooked until they reached an internal temperature of 71°C. Cooked steaks were allowed an approximate 3 min rest time before they were trimmed of external fat, placed into a grid cutter, and cut into 1-cm x 1-cm x 2.5-cm sample cubes. Cubes were held in porcelain double boilers, lined with aluminum foil, and heated to approximately 60°C to maintain temperature before allocation to individual sample cups. Samples were transferred to lidded, 4 oz. foam cups with random 3-digit codes specific to each treatment code. The foam cups were held until served inside a proofing cabinet (Win-Holt NSF ETL, Syosset NY, Model #NHPL – 1836C) set to a temperature of 54 – 60°C and a humidity of setting 9. Each participant received two samples per treatment and were provided with distilled water.

Participants were first asked to assess aroma liking. They were instructed to evaluate sample aroma by partially opening the sample lid and observing the aroma of the sample. Participants were then instructed to taste one of the sample cubes and rate it for overall liking, liking of flavor, and liking of texture. Participants were then instructed to taste the second piece and rate tenderness, juiciness, and off-flavor intensity. Liking ratings were made on 120-point labeled affective magnitude scales, with the left most end labeled ‘greatest imaginable disliking’ and the right most end labeled ‘greatest imaginable liking’. Intensity ratings were made on 20-point line scales with the left most ends labeled ‘none’ and the right most ends labeled ‘extremely intense’ for off-flavor, ‘extremely juicy’ for juiciness, and ‘extremely tough’ for toughness. Participants who rated the off-flavor at an intensity of 10 or more were required to answer the following open-ended question: “Please describe, as specifically as you can, what this off-flavor was.” After rating the samples participants were asked “Now that you have tasted three samples of bison, if bison was available at your local grocery store at a reasonable price, would you consider purchasing and consume it?” Finally, participants answered questions about their frequency of bison meat consumption and their gender. A copy of the ballot completed by participants is included in Appendix A.

### *Statistical Analysis*

Live body weight, dressing percent, carcass measurements, shear force, cook loss, storage conditions (fresh vs. frozen for cook loss and shear force analyses), fatty acid profile, cholesterol content, and proximate analysis data were analyzed using the MIXED procedures of SAS (SAS Inst. Inc., Cary, NC). Subjective carcass measurements, including

fat color, lean, and skeletal maturity, and USDA Yield Grade data were analyzed using the GLIMMEX procedures of SAS for the main effect of finishing treatment. Kill date was included as a random effect, and peak temperature was used as covariate for shear force and cook loss. The interaction of storage conditions finishing treatment were not significant for shear force or cook loss and was omitted from the final model. Cook loss and shear force samples were subjected to different postmortem aging periods before they frozen and were analyzed as repeated measures using the ante-dependence covariance structure in the MIXED procedure of SAS for effects of finishing treatment, aging, and their interaction; peak temperature was included as a covariate. The interaction of postmortem aging and shear force was not significant for shear force and omitted from the model. Consumer preference data was analyzed using the MIXED procedures of SAS for the main effects of finishing treatment and serving order; time and panelist were used as random effects. For all attributes except toughness and juiciness ratings, serving order was not significant and omitted from the final model. Separation of least-squares main effect means was performed using LSD with a Tukey's adjustment and assuming an alpha level of 0.05. Carcass served as the experiment unit for all carcass and meat quality analyses, and the individual panelists served as the experimental unit for sensory analysis.

## **Results and Discussion**

### ***Carcass Characteristics***

In the United States, bison are classified by USDA Food Safety Inspection Service as a non-amenable or "exotic" specie, carcass inspection is voluntary for bison, and there is no established carcass yield or quality grading system for the specie.

Therefore, carcass measurements evaluated in this study are standard measurements utilized in determining yield and quality grades of beef carcasses, however, the Canadian bison carcass grading system will be referenced when relevant. Also, as there is limited research investigating bison carcass characteristics, therefore results from beef studies will be discussed to provide context. The anatomy and conformation of bison carcasses differ somewhat from beef carcasses. Fat distribution of bison carcasses is described as less uniform than beef and a higher percentage of fat is distributed over the rib primal compared with beef (Koch et al., 1995). Bison generally have lighter finished weights and HCW, a smaller ribeye area, decreased marbling deposition, increased backfat, and achieve market readiness at a later chronological age than beef cattle (Koch et al., 1995). The slaughter age of 28 mo in the present study is within the range of 24 to 31 mo reported in other bison studies (Hawley, 1986; Marchello et al., 1989; Marchello et al., 1998; Marchello and Driskell, 2001; Rule et al., 2002).

Live weight and carcass data are reported in Table 2-1. USDA-AMS marketing reports indicate that the average dressed HCW for bison heifers is 270 kg (USDA-AMS, June 2019), which closely aligns with the HCW of the grain-finished treatment (281 kg) in the current study. Carcass weight of bison heifers (229 kg) reported by Lopez-Campos et al. (2014) is similar to the grass-finished treatment in the present study (226 kg). Ribeye area of bison heifers was 64.58 cm<sup>2</sup> and 57.48 cm<sup>2</sup> for grain- and grass-finished respectively. These results to others reporting ribeye area of 61.2 cm<sup>2</sup> for bison heifers, 67.4 cm<sup>2</sup> for bison bulls (Spronk et al., Year Unknown), and 60.5 cm<sup>2</sup> for bison steers (Hawley, 1986). Ribeye area is not included in the Canadian bison grading system. Koch et al., (1995) reported bison averaged 2.21 cm of backfat thickness, which is similar to

the backfat thickness of the grain finished heifers (2.16 cm) in the present study. In Canada, bison carcasses exhibiting greater than 1.2 cm of backfat are classified as over-finished, and the desirable backfat thickness range for the Canadian system is 0.2 to 1.2 cm (Galbraith et al., 2014). Therefore, the backfat thickness of heifers in the grass-finished treatment (0.89 cm) would be more ideal in the Canadian system. Marbling scores of bison heifers in the current study were 389 and 244 for grain- and grass-finished respectively. These results are similar to scores reported by Lopez-Campos et al. (2014) for bison heifers (368) and by Koch et al. (1995) for bison bulls (319). Marbling scores ranging from 200-400 would classify bison carcasses as “practically devoid” to “slight” amounts of marbling using the USDA beef quality grading system, therefore qualifying the carcasses as either Standard or Select (American Meat Science Association; AMSA, 1990). The Canadian bison grading system does not include marbling scores.

Grain-finished bison heifers had heavier ( $P < .0001$ , Table 2-1) live and hot carcass weights (HCW) than grass finished heifers (Table 2-1). Grain finished heifers also had increased dressing percentage, kidney pelvic heart fat (KPH), ribeye area, back fat, and marbling scores compared to grass-finished heifers. However, proportions of carcasses in each Yield Grade category did not differ ( $P > .05$ ) between treatments. Results of this study are similar to studies investigating the effects of finishing systems on beef cattle. Duckett et al. (2013) reported forage finished steers had lighter final body weight, HCW, and decreased dressing percentage compared with concentrate finished steers that were harvested at a similar number of days on feed. This result is in agreement with other studies reporting forage-finishing results in lighter carcass weights compared to concentrate finishing when harvested at similar a finishing endpoint (Crouse et al., 1984; Bennett et al.,

1995; Neel et al., 2007). Similar to the bison results in the present study, Duckett et al. (2013) reported concentrate finished beef steers had increased ribeye area, fat thickness at the 12<sup>th</sup> rib, KPH, and marbling scores compared to forage finished. These results are in agreement with previous research in beef by Duckett et al. (2007) and Neel et al. (2007) and support that concentrate finished beef cattle have increased weights and yield related carcass characteristics, as well as more marbling. Marbling is considered an important meat quality characteristic due its positive influence on tenderness, juiciness, and flavor. Therefore the amount of marbling present at the ribeye area is an important factor utilized to determine quality grades of beef carcasses in the United States, and previous beef studies indicate that marbling content can be increased by feeding a higher concentrate diet (Muir et al., 1998; Leheska et al., 2008; Duckett et al., 2013).

#### ***Carcass Maturity and Subjective External Fat Color***

There was no difference ( $P > .1000$ ) in the percentage of grain- and grass-finished bison heifers classified as ‘extreme hardbone’ (100-200% ossification,) or ‘moderate’ (25-49% ossification) for skeletal maturity (Table 2-1). There was a tendency for a greater percentage ( $P = .0582$ ) of grain-finished heifers to be classified as ‘hardbone’ (50-99% ossification) compared to grass-finished. A greater percentage ( $P = .0037$ ) of grass-finished heifers were classified as ‘slight’ (0-24% ossification) for skeletal maturity compared to grain-finished. Overall, a majority of grass-finished heifers were classified as ‘slight’ (44.88%), while grain-finished were more distributed amongst ‘slight’ (24.32%), ‘moderate’ (36.84%), and ‘hardbone’ (28.69%) classifications. Regardless of finishing system, the ‘extreme hardbone’ category included the lowest percentage of bison heifers



(7.71 and 6.25% for grain- and grass-finished respectively). Skeletal maturity has been shown to increase as the percentage of concentrate in the diet is increased in beef (Owens and Gardner, 2011).

There was no difference ( $P > .1000$ ) in the percentage of grain- and grass- finished bison heifers classified as 'red', 'slightly bright red', or 'moderately bright red' for lean maturity (Table 2-1). An increased percentage ( $P = .0116$ ) of grass-finished heifers were classified as 'pale red' compared to grain-finished heifers, while an increased percentage ( $P < .0001$ ) of grain-finished heifers were classified as 'bright red' compared to grass-finished heifers. Overall, the majority of grain-finished heifers were classified as 'bright red' (41.64%), while grass-finished heifers were more distributed amongst 'red' (24.73%), 'slightly bright red' (22.58%), and 'moderately bright red' (30.11%) classifications. Regardless of finishing system, the fewest carcasses were classified as 'pale' (0.74 and 9.97% for grain- and grass-finished respectively). The relationship between skeletal and lean maturity results reveal that grain-finished bison heifers exhibit an increased physiological maturity compared to grass-finished heifers at a similar chronological age.

There was no difference ( $P > .1000$ ) in the percentage of heifers classified as 'slightly white' for external fat color (Table 2-1). An increased percentage ( $P < .0001$ ) of grass-finished heifers were classified as 'moderately yellow' compared to grain-finished heifers, while an increased percentage ( $P < .0001$ ) of grain-finished heifers were classified as 'moderately white' compared to grass-finished heifers. Overall, the majority of grain-finished heifers were classified as 'moderately white' (64.89%), while majority of grass-finished heifers were classified as 'moderately yellow' (52.67%). Van Elswyk and McNeil's (2014) reviewed the impacts of forage versus graining finishing diets in beef and

reported grass-fed beef to have increased yellowness of external fat. This is likely due to increased  $\beta$ -carotene deposition within adipose tissue of forage finished animals (Duckett et al., 2009 and 2013).

Due to their unique carcass characteristics, Canada has an established bison grading system with 10 grades (A1 – 4, B1 – 3, and D1 – 3) dispersed into two different maturity classes (Maturity Class I, youthful; includes A1-4 and B1-3) and (Maturity Class II, mature; includes D1-3). Physiological maturity is determined by the degree of ossification present on the cartilage caps over the ends of the 9<sup>th</sup>, 10<sup>th</sup>, and 11<sup>th</sup> thoracic processes, where youthful carcasses have 80% or less ossification of the caps and mature carcasses have greater than 80% (Galbraith 2014). The Canadian grading system relates animal maturity, or age, directly to tenderness, in which youthful carcasses are most tender. Utilizing the current Canadian bison grades, a majority of carcasses in this present study would be classified as ‘youthful’, however a greater percentage of grass-finished would fall into this classification than grain-finished heifers (74.78 to 61.60% respectively). A greater percentage of grain-finished bison heifers would be classified as ‘mature’ compared to grass-finished (36.40 to 23.44% respectively).

Other grade factors included in the Canadian grading system are degree of muscle color (lean maturity) and external fat color, which influence consumer acceptance and shelf-life (CBA: Grading and Labelling of Canadian Bison, 2020). Therefore, bright red muscle color and white to amber fat color is preferred for carcasses in the A1-A4 and B1 grades, compared to a dark red muscle and yellow fat colors, which would be classified as B2 or B3 grades. When referencing the Canadian system grain-finished carcasses in this study would be more desirable for fat and muscle color, as a majority were classified as

moderately white for external fat color and bright or moderately bright red for lean muscle color compared to grass-finished.

### ***Objective Color and Ultimate pH***

Instrumental color values ( $L^*$ ,  $a^*$ ,  $b^*$ ) of the exposed ribeye and  $a^*$  value of the external subcutaneous fat opposite the ribeye were increased ( $P < .0001$ ; Table 2-2) for grain-finished heifers. However,  $L^*$  and  $b^*$  values of subcutaneous fat opposite the ribeye were increased ( $P < .0001$ ; Table 2-2) for carcasses from the grass-finished system. Finishing system did not influence ( $P > .1000$ ; Table 2-2) ultimate pH of bison striploins. In a comparison between bison and beef, Koch et al. (1995) reported that bison muscles were darker than beef. While species differences are reported, the influence of finishing system on objective color of beef is generally in agreement with the current study reporting lighter lean color (greater  $L^*$ ) for beef finished on a concentrate diet as opposed to forage finished (Crouse et al., 1984; Bennett et al., 1995; Duckett et al., 2007; Duckett et al., 2013). Duckett et al., (2007) hypothesized that the darker lean color of foraged finished beef was related to increased muscle pH, however no differences were detected in pH in the current study. Others have attributed darker lean color to increased myoglobin content (Bidner et al., 1986), and more muscle myoglobin caused by increased physical activity of forage finished animals compared to animals finished in a feedlot (Varnam and Sutherland, 1995). In contrast to the present study, Duckett et al. (2013) reported no difference in longissimus muscle  $a^*$  or  $b^*$  between beef finishing systems. This could be due to differences in specie and diet composition between the two studies. Similar to this present study, Duckett et al. (2013) reported that  $a^*$  values of the subcutaneous backfat were

increased for grain-finished beef, while the  $b^*$  values were increased for forage-finished beef. However, in contrast to the present study no differences in  $L^*$  values of the subcutaneous backfat of beef were reported (Duckett et al., 2013).

Chail et al. (2016) and French et al. (2001) compared beef cattle finishing on a forage diet in a grazing system and on a concentrate diet in a feedlot system also report no difference in ultimate muscle pH between treatments. In contrast Duckett et al. (2013) and Muir et al., (1998) detected higher ultimate pH in grass fed beef. French et al. (2000) suggested that grass-fed steers were more susceptible to pre-slaughter stress than grain-finished, which would be more accustomed to handling and penning. Bison heifers used in the present study were accustomed to various handling practices, received the same pre-slaughter handling, were the same age, and were killed within a two-day period, all of which may contribute to the lack of difference in pH.

### ***Proximate Chemical Composition***

Steaks from grain-finished heifers had increased ( $P < .05$ ) crude protein and fat content but decreased ( $P < .0001$ ) moisture content compared to steaks from grass-finished bison heifers. Percentage of ash did not differ ( $P > .1000$ ) between finishing treatments (Table 2-3). These results closely follow compositional values reported by Marchello and Driskell (2001) and Marchello et al. (1998); however only means were reported in these studies, therefore statistical differences between treatments cannot be distinguished. Overall the limited studies on bison meat composition suggest that bison is lower in fat content (1.3-5.0%) than beef (3.0-10%) (Morris et al. 1981; Hawley 1986; Savell et al. 1986; Koch et al. 1995; Marchello and Driskell, 2001; Marchello et al., 1998), which may

be related to a greater percentage of bison that are grass-finished and the lack of genetic selection for marbling. Grain-fed animals generally consume high levels of energy in a high concentrate diet, which allows excess energy to be used to develop intramuscular fat (Leheska et al., 2008). Results comparing grass- and grain-fed beef reported no difference in ash and protein contents between treatments, but a decrease in total fat content and subsequent increase in percent moisture of grass-finished compared to grain-finished samples (Leheska et al., 2008). This relationship between fat and moisture content has been reported by others investigating the proximate analysis of meat samples (Reagan et al., 1977; Duckett et al., 1993).

### ***Cholesterol Content***

The grain-finishing system produced steaks with increased ( $P = .0073$ ) cholesterol content compared to grass-finished (Table 2-3). Cholesterol content was 54 and 51 mg/100 g for grain- and grass-finished heifers respectively. These are lower than the cholesterol values (66 and 65 mg/100g for grain and grass respectively) reported by Marchello and Driskell (2001); Marchello et al. (1998) but this is likely due to the fact that several cuts (ribeye, top sirloin, top round, and shoulder clod) were averaged in those reports compared to only the striploin in the current study.

Cholesterol is a major component of animal plasma membranes, as it is a vital structural component of cell membranes and the precursor of bile acids and steroid hormones (Voet et al., 2006). Yet cholesterol is perceived to have negative effects on health, resulting in public concern over the cholesterol content in red meat products (Li et al., 2005). Eichhorn et al. (1986) determined that adipose tissue contains about 2 times as

much cholesterol as muscle tissue. However, all steaks in this study were trimmed of all external fat; therefore, the only fat source was from intramuscular fat. Intramuscular fat has been found to contain less cholesterol than intermuscular fat (Sweeten et al., 1990). It has been suggested that beef finished on grass yield steaks that are lower in cholesterol compared to those from a grain-finished system (Daley et al., 2010), however this is not consistent across all studies. Some beef studies report no difference between grass and grain treatments (Duckett et al., 2009 and 2013; Leheska et al., 2008) and others report reduced cholesterol content of grass-finished beef steaks from the round and chuck compared to grain-finished (Rule et al., 2002). Rule et al. (2002) also reported cholesterol content was decreased for the *longissimus dorsi*, *semitendinosus*, and *supraspinatus* muscles of range-raised bison compared to feedlot finished bison. When comparing the cholesterol content of muscles across different species (bison, elk, and beef) raised using different finishing systems, Rule et al., (2002) noted that cholesterol content was lowest in the *longissimus dorsi* of range-raised bison compared to the other species and feedlot finished bison. However, the different dietary and species groups used by Rule et al. (2002) included animals of various ages and sexes, which could also have impacted the reported results. Ultimately, for meat to be classified as 'lean' it must contain <95 mg/100g cholesterol (2010 US Dietary Guidelines). Therefore, bison steaks from both finishing systems in the present study would qualify as lean as they are well under the minimum requirement.

### ***Fatty Acid Profile***

The majority of fatty acids concentrations were influenced by finishing treatment (Table 2-4); with the exception of C12:0, C16:1 trans, C18:2 trans, C18:3n3 (linolenic acid) C20:2, C20:6n3, C22:3, and C22:6n3 [docosohexanaenoic acid (DHA)] when reported on mg/g raw tissue basis, and C12:0 and C14:0 when reported on a percentage of total fatty basis. Grain-finished bison produced steaks with increased ( $P < .05$ ) total concentrations of saturated fatty acids (SFA), monounsaturated fatty acids (MUFA), polyunsaturated fatty acids (PUFA), and overall total lipids (mg/g of wet tissue) compared to grass-finished. However, when expressed as a percentage of total lipid, grass-finished samples had increased total concentrations of PUFA ( $P < .0001$ ) and SFA ( $P = .0219$ ), while MUFA remained elevated ( $P < .0001$ ) in grain- compared to grass-finished steaks.

Results of this study are similar to studies investigating the effects of finishing systems on beef cattle. Beef studies reviewed by Van Elswyk and McNeil (2014) revealed that SFA content, when reported as percent of total fatty acid basis, is increased in grass-fed and decreased in grain-fed. However, given that grass-fed beef is generally lower in total fat content, this percentage does not translate into an increased intake of total SFA in a g/100g serving size, therefore grain-fed was found to have increased SFA on a serving size basis. Rule et al. (2002) compared the nutrient composition of bison placed on different finishing systems. When reported on a total fat percentage basis, grass-finished bison also averaged increased total SFA and PUFA content but decreased monounsaturated fatty acids when compared to grain-finished bison (Rule et al., 2002).

Oleic acid is the predominate fatty acid in meat (Aberle et al., 2001); therefore, it was not surprising that oleic acid concentrations comprised a majority of both grain- and

grass-finished bison steaks in the current study. Concentrations of oleic acid in bovine adipose tissue is dependent upon the activity of delta-9 desaturase, which is the enzyme responsible for the conversion of all SFAs to their respective MUFAs. (Smith et al., 2006). The decreased MUFA content of grass-finished beef likely due to the effect of desaturase enzyme activities (Smith et al., 2006). As intramuscular lipid accumulates, there is an associated elevation in the concentration of oleic acid, ranging from 30% to 50% of total adipose tissue fatty acids (Chung et al. 2006). Results from the current study fall within this reported range, as oleic acid concentrations were 45.60% for grain-finished and 37.38% for grass-finished bison steaks. Increased oleic acid concentrations for grain-finished bison steaks is supported by an increase presence of IMF content reported both by subjective and chemical evaluations.

Forage feeding systems generally result in an increase of PUFA:SFA ratio in ruminants (Rule et al., 1995, Cordain et al., 2002). However, overall content of PUFAs within red meat is generally low, only averaging only 5% in beef species (Scollan et al., 2006). However, results in the current study report bison PUFA concentrations well above 5% of total fatty acids regardless of finishing systems (13.75% and 20.53% respectfully). Larrick et al. (1989) reported that bison had decreased total fat content but increased PUFAs compared to *Bos taurus*, and *Bos indicus* cattle. Rule et al. (2002) reported that range-fed bison, beef, and elk cows had similar fatty acid compositions, specifically the n-3 and n-6 PUFAs. Range-fed beef and bison cows had greater portions of PUFA compared to feedlot cattle and bison.

Grain-finished bison steaks had an increased ( $P < .0001$ ) n-6:n-3 ratio but a decreased ( $P = .0006$ ) PUFA:SFA compared to grass-finished steaks. Diets having greater



ratios of PUFA: SFA ( $>0.45$ ) and lower n-6:n-3 ratios ( $<4.0$ ) may reduce the incidence of coronary artery disease (Simopoulos 2004). Both grain- and grass-finished bison steaks in this study had an n-6:n-3 ratio  $>4.0$ , yet grass-finished steaks had a significantly lower ratio than grain-finished (4.64 to 5.74 respectfully). Grass-finished steaks also had an increased PUFA:SFA ratio compared to grain-finished (0.58 to 0.41), however the grain-finished steaks were closer to the recommended ratio of  $>0.45$ . Grass finishing systems generally result in a decreased n-6:n-3 ratio in ruminants (Rule et al., 1995, Cordain et al., 2002). Results from Rule et al., (2002) reports samples from the *longissimus dorsi* of range fed bison had a n-6:n-3 ratio of only 1.94, while the feedlot bison had a ratio similar grain-finished steaks in the present study of 5.73. However, the total portions of PUFA reported by Rule et al., (2002) were decreased compared to the portions reported in the current study for both grass- (20.53% vs. 16.5%) and grain- (13.75. vs. 10.70%) finished bison. As a result, Rule et al. (2002) PUFA:SFA ratio was also decreased compared to the ratio reported in this study. The large differences between this study and ratios reported by Rule et al., (2002) could be due to different animal ages and sexes.

### ***Warner-Bratzler Shear Force***

The grain-finished system produced more tender ( $P = .0131$ ) steaks than grass-finished (Figure 2-1). Tenderness of all bison steaks improved ( $P < .0001$ ) with postmortem aging (Figure 2-2). Steaks aged 4 days were toughest ( $P < .0001$ ), followed by 7 day ( $P = .0246$ ). Steaks aged 14 days were more tender than 4 and 7 day aged but did not differ ( $P > .1000$ ) from 21-day aged samples. It is well established that beef tenderness increases during postmortem storage of carcasses at refrigerated temperatures (Huff-Lonergran et

al., 1995). A factor involved in this increase in tenderness is postmortem loss of structural integrity of myofibrils (Parrish et al., 1973; Koohmaraie et al., 1987) and other cytoskeletal elements (Robson et al., 1984, 1991) of the muscle cell. Tenderization occurs at a relatively rapid rate until 3 to 7 days postmortem, and then the rate diminishes with time, such that the improvement in tenderness of beef loins after 7 to 10 days is relatively small compared to the first 10 days (Parrish et al., 1973; Parrish et al., 1991; Huff 1993; Huff-Lonergran et al., 1996)). Bison steaks in the current study appear to follow these postmortem aging trends, as tenderness improvements were observed until 14 days postmortem, then remaining stable.

A review of several studies comparing grass-fed and grain-fed beef concluded that grass-fed beef was less tender than grain-finished (Van Elswyk and McNeil, 2014), which was suggested to be partially due to decreased MUFA deposition resulting from the effects of delta-9 desaturase enzyme activity (Smith et al., 2006). Delta-9 desaturase is responsible for the conversion of all SFA to their respective MUFA. (Smith et al., 2006). Early research demonstrated that MUFAs, specifically the concentration of oleic acid (18:1n-9), in beef is positively correlated with its overall palatability (Waldman et al. 1968; Westerling & Hedrick 1979). This may be improvement in palatability may be related to fat softness, because beef lipids enriched with oleic acid have lower melting points (Smith et al. 1998; Wood et al. 2004; Chung et al. 2006). In the present study, grain-finished bison produced steaks with increased concentrations of oleic acid both on a mg/g wet tissue basis and on a percentage of total fatty acids basis compared to grass-finished.

Larger quantities of fat insulate the carcass, slowing postmortem chilling, which improves tenderness by preventing cold-induced muscle shortening in the *Longissimus*

*dorsi* and some other muscles (French et al., 2001). However, French et al., (2001) reports no difference in sarcomere lengths between forage- and grass-finished beef carcasses, despite differences in carcass weights, fat thickness and IMF content, indicating that cold shortening likely did not occur. While grain-finished bison heifers had increased backfat thickness, sarcomere length was not evaluated and therefore the potential for cold shortening of muscles cannot be determined in this study. A slower postmortem chilling rate in grain-finished carcasses with more external fat may also be more favorable for postmortem muscle autolysis (Lochner et al., 1980; Smith et al., 1976), however chilling rate was not evaluated.

Aberle et al. (1981) and Fishell et al. (1985) determined that pre-slaughter feeding, and growth rate had a direct effect on collagen stability and the tenderness of beef. Cattle fed high energy diets experience rapid rates of protein synthesis, and, therefore, the meat produced from these animals would be expected to contain a large proportion of newly synthesized, heat-labile collagen (Aberle et al. 1981; Fishell et al. 1985). Shimokomaki et al. (1972) showed that changes in collagen crosslinking are related more closely to growth rate and animal maturity than chronological age. Hall and Hunt (1982) proposed that cattle fed low energy diets grow at slower rates than cattle fed high energy diets. Therefore, at a certain chronological age, forage-fed cattle would be physiologically less mature than their grain-fed contemporaries. As a result, cattle quickly reaching maturity are likely to contain more soluble collagen and have more tender meat. In the present study all heifers were slaughtered at a common age (28 mo), and a majority of grain-finished heifer carcasses were in the 'moderate' and 'hardbone' classifications for skeletal ossification, while more grass-finished carcasses were classified as 'slight'.

While the current study did not assess differences in carcass temperature decline, sarcomere length, collagen content, delta-9 desaturase activity, or proteolysis between samples from grain- or grass-finished bison heifers, future studies could evaluate these factors to determine the mechanism by which tenderness is improved in grain-finished bison.

### ***Cook Loss***

Cook loss was affected ( $P = .0475$ ) by the interaction of finishing treatment with aging period (Figure 2-3). Overall grain-finished steaks had less ( $P < .0001$ ) cook loss than grass-finished. Cook loss decreased for grass-finished from days 4 to 7 ( $P = .0468$ ) but remained stable from days 7 to 21 ( $P > .1000$ ). Cook loss of grain-finished steaks did not differ between aging days ( $P > .1000$ ) and remained stable across aging days. All grain-finished steaks had decreased cook loss compared to 4-day grass-finished steaks, however only 7-day grain-finished steaks had decreased cook loss compared to grass-finished steaks aged 7, 14, and 21 days. Bruce et al. (2003) reported that beef *longissimus thoracic* steaks aged 14 days had increased cook loss compared to those aged for 1 d. Increased cook loss of aged steaks may be influenced by protein degradation during the aging process (Warriss & Brown, 1987). Additionally, as reported above, proximate analyses revealed that grass-finished steaks had increased moisture content, but decreased fat content compared to grain-finished. These differences in moisture and fat content between steaks could help explain cook loss differences between finishing treatments, as the moisture content is typically reduced in cuts with a greater total fat content (Wahrmund-Wyle et al., 2000). Additionally, increased intramuscular fat content lubricates the muscle fibers and fibrils,

creating an insulation barrier during the use of high-temperature, dry-heat methods of cooking, and/or a greater degree of doneness without adversely affecting the palatability of the meat (Savell and Cross 1988). The increased moisture content of the grass-finished bison steaks is likely due to its decreased intramuscular fat content, which allowed for increased moisture content to escape during cooking due to the lack of a protective thermal barrier.

### ***Influence of Storage Condition (Fresh vs Frozen) on Tenderness and Cook Loss***

Bison steaks kept in frozen storage conditions had improved tenderness ( $P < .0001$ ) but increased ( $P = .0001$ ) cook loss compared to bison steaks kept in fresh storage conditions (Table 2-5). Shear force results are in agreement with Lopez-Campos et al. (2014) who reported that shear force values of striploin steaks from bison bulls and heifers aged for 20 days then frozen were decreased compared to fresh steaks. Others have also concluded that frozen storage improves tenderness of beef (Law et al., 1967; Shanks et al., 2002) and lamb (Smith et al., 1968). Shanks et al., (2002) suggested that freezing results in intracellular ice formation, which causes a physical disruption of muscle cells. Hiner et al. (1945) suggested that freezing causes muscle fibers to rupture and induces stretching and rupture of connective tissues. It is possible that storage temperature, and/or duration of frozen storage may affect the amount of intracellular ice formation and physical disruption occurring in muscle, and thus the extent to which freezing influences tenderness (Shanks et al., 2002). Smith et al., (1969) reported freezing for a duration of 3 to 6 wks had no effect on tenderness, but reported that WBSF values decreased for beef stored frozen for 4 mo.

Shanks et al., (2002) found no effect of storage conditions on cook loss of beef

striploin steaks aged 14, 21, or 35 days postmortem and suggests that as meat ages and proteins degrade, muscle loses its inherent ability to hold moisture, however in the frozen protocol, cellular damage due to freezing may have outweighed this effect. Therefore, there would be little change in cook loss following freezing for steaks that were aged for longer period of time (Shanks et al., 2002). Despite results reported by Shanks et al., (2002), others have reported that beef steaks held in frozen storage conditions have increased cook loss values (Pearson and Miller, 1950; Crouse and Koohmaraie, 1990; Hildrum et al., 1999).

In the United States, the average aging day period for fresh beef at retail is 18-22 days, based on postmortem fabrication times reported in the 1991 and 1998 National Beef Tenderness Surveys (Morgan et al., 1991; Brooks et al., 2000). Therefore, the majority of beef tenderness research is conducted on steaks aged 14 to 21 d to simulate industry conditions (Shanks et al., 2002). Currently, there are no national surveys reporting average aging periods for fresh bison from fabrication to retail.

### ***Consumer Preference***

No treatment differences ( $P > .1000$ ) were detected by consumer panelists (n=113) for overall liking, aroma liking, flavor liking, texture liking, toughness intensity, juiciness intensity, or off-flavor intensity of bison steaks (Table 2-6). The liking ratings were made on 120-point labeled affective magnitude scales (see Appendix A for example ballot) ranging from greatest imaginable disliking to greatest imaginable liking. Consumer responses revealed that all scores ranged from “like slightly” to “like moderately.” Intensity ratings were made on 20-point line scale (see Appendix A for example ballot) with the left most ends labeled none and the right most ends labeled extremely juicy, extremely tough,

and extremely intense for off-flavor. Results for intensity ratings revealed means to be less than 10 for each attribute. Off-flavor intensity scores were the lowest, while juiciness scores were the greatest. Participants that rated off-flavor intensity at 10 or above were required to answer an open-ended question: “Please describe as specifically as you can, what this off-flavor was.” An off-flavor intensity of greater than 10 was reported by 12.39% of participants (n=14) for grain-finished and 10.61% (n=12) for grass-finished. Common descriptions in the unedited responses for grass-finished steaks included: “sour, “rancid,” liver, gamey, and fishy,” while responses from grain-finished steaks included: “metallic, grilled corn, bitter, sour, and neutral flavor like beef” (see Appendix B1 for unedited responses). After rating all samples, participants were asked: “Now that you have tasted samples of bison, if bison was available at your local grocery store at a reasonable price, would you consider purchasing it?” Results from this question indicate that a majority of participants were willing to consider purchasing and consuming bison ‘regularly’, ‘regularly but not as often as other meats’, or ‘occasionally’. Only two participants (1.77%) responded ‘no, I would not consider purchasing and/or consuming bison meat’ (see Appendix B2 for results). Panelists’ demographic information is presented in Appendix tables C1-4.

Trained sensory panels by Koch et al. (1995) found bison steaks to be more tender than beef, however objective shear force values were not different between these species. Trained sensory panels indicated that bison meat had an intense off-flavor compared to beef, and the off-flavors were described as an intense “ammonia, metallic, and gamey flavor” (Koch et al., 1995). A similar trained sensory panel comparing shortloin steaks from bison to steaks from *Bos taurus* and *Bos indicus* cattle by Larick et al. (2008) also

reported that bison samples exhibited more off-flavor and aftertaste presence compared to both cattle species. These flavor notes were characterized as increased levels of ammonia, bitter, gamey, liverish, old, rotten, and sour (Larick et al., 2008). Flavor differences discussed by Larrick et al. (2008) could be an outcome of fatty acid composition, specifically the increased PUFA content measured in bison against both cattle species. Polyunsaturated fatty acids can be responsible for the oxidized flavor during storage (Igene et al., 1980), or warmed over-flavor in meats (Pearson et al., 1977), and they are degraded during cooking (Keller and Kinsella, 2006). However, results reported here for off-flavor intensities show no differences between bison finishing systems for off-flavor. More participants rated grain-finished steaks above score of 10 for off-flavor intensity, yet steaks from grass-finished bison steaks had increased PUFA concentrations when expressed on a percentage of total lipids.

Despite differences reported in shear force values, there was no significant difference in sensory evaluations for toughness scores between bison finishing systems in the present study. It is important to note that as there was no aging day x treatment interaction for WBSF values reported are main effect means including all aging periods (4, 7, 14, and 21 d). Steaks utilized for the sensory panel were aged for 14 d. The shear force values for the 14 d samples were 2.54 and 2.74 kg respectfully for grain- and grass-finished steaks. The ASTM beef tenderness claim standards include a minimum tenderness threshold value (MTTV) of 4.4 kg for WBSF and is representative of instrumental and sensory research conducted for tender beef classification (ASTM International, 2011). The shear force results in the current study, regardless of finishing system, are well below the MTTV. Further, a 0.5 kg difference in WBSF values represents the difference in shear



force that the average consumer can detect when consuming meat (ASTM International, 2011), therefore given the 14 d aged shear force values of this study, it is not surprising that the panelists were not able to detect tenderness differences between finishing systems. Additionally, Miller et al. (2002) classified steaks with a shear force value  $< 3.0$  kg to be very tender, which could allow for premium opportunities. Bison steaks from both finishing systems aged for at least 14 d were below 3.0 kg, indicating they have favorable eating quality characteristics.

### **Conclusions**

Collectively these data indicate that finishing systems influence bison carcass characteristics and meat quality. Bison heifers placed on a grain-finished system had increased dressing percentages, carcass weights, back fat, ribeye area, marbling scores, and KPH compared to grass finished. Finishing system influenced nutrient content and fatty acid composition, which may have health implications, as grass-finished bison steaks exhibited a decreased cholesterol content, percent fat, and n6:n3 fatty acid ratio, but an increased PUFA:SFA ratio and PUFA proportions when expressed on percentage of total fatty acid basis when compared to grain-finished bison steaks. Steaks from grain-finished bison heifers were more tender and exhibited decreased cook loss compared to grass-finished. Additionally, there are benefits and disadvantages for utilizing different storage systems; as bison steaks kept in frozen storage conditions were more tender but had increased cook loss compared to steaks kept in fresh storage conditions. Differences exhibited in carcass and meat quality characteristics do not translate to changes in consumer preferences. Overall shear force and sensory results from this study indicate that

bison produced from either grain- or grass-finishing systems provides a favorable eating experience. However further investigation utilizing a trained sensory panel could aid in determining meat palatability differences between finishing systems.

### **Literature Cited**

Aberle, E. D., J.C. Forrest, D. E. Gerrad, E. E. Mills. 2001. Principles of Meat Science.

Kendall/Hunt, Dubuque, Iowa. 4<sup>th</sup> edition.

Aberle, E. D., E. S. Reeves, M. D. Judge, R. E. Hunsley, and T. W. Perry. 1981.

Palatability and Muscle Characteristics of Cattle with Controlled Weight Gain:

Time on a High Energy Diet. *Journal of Animal Science* 52(4):757-763.

American Meat Science Association. 1990. Recommended procedures for beef carcass

evaluation and carcass contents. 3rd ed. AMSA, Chicago, IL.

AOAC International. 1996. Official Methods 994.10: Cholesterol in Foods-Direct

Saponification-Gas Chromatographic Method. Association of Official Analytical

Chemists, Arlington, VA.

ASTM International. 2011. Standard specification for tenderness marketing claims

associated with meat cuts derived from beef. ASTM Standards. F2925-11.

Accessed 02 August 2020

[.https://www.ams.usda.gov/sites/default/files/media/F2925-](https://www.ams.usda.gov/sites/default/files/media/F2925-11%20Standard%20Specification%20for%20Tenderness.pdf)

[11%20Standard%20Specification%20for%20Tenderness.pdf](https://www.ams.usda.gov/sites/default/files/media/F2925-11%20Standard%20Specification%20for%20Tenderness.pdf)

Bennett, L. L., A. C. Hammond, M. J. Williams, W. E. Kunkle, D. D. Johnson, R. L.

Preston, and M. F. Miller. 1995. Performance, carcass yield, and carcass quality

- characteristics of steers finished on rhizoma peanut (*Arachis glabrata*)-tropical grass pasture or concentrate. *J Anim Sci* 73(7):1881-1887.
- Bruce, H. L., and R. O. Ball. 1990. Postmortem interactions of muscle temperature, pH and extension on beef quality. *Journal of Animal Science* 68(12):4167-4175.
- Bidner, T. D., A. R. Schupp, R. E. Montgomery, and J. C. Carpenter, Jr. 1981. Acceptability of Beef Finished on All-Forage, Forage-Plus-Grain or High Energy Diets. *Journal of Animal Science* 53(5):1181-1187.
- Bidner, T. D., A. R. Schupp, A. B. Mohamad, N. C. Rumore, R. E. Montgomery, C. P. Bagley, and K. W. McMillin. 1986. Acceptability of Beef from Angus-Hereford or Angus-Hereford-Brahman Steers Finished on All-Forage or a High-Energy Diet. *Journal of Animal Science* 62(2):381-387.
- Brooks, J. C., J. B. Belew, D. B. Griffin, B. L. Gwartney, D. S. Hale, W. R. Henning, D. D. Johnson, J. B. Morgan, F. C. Parrish, Jr., J. O. Reagan, and J. W. Savell. 2000. National Beef Tenderness Survey-1998. *J Anim Sci* 78(7):1852-1860.
- Bruns, K. W., R. H. Pritchard, and D. L. Boggs. 2004. The relationships among body weight, body composition, and intramuscular fat content in steers<sup>1</sup>. *Journal of Animal Science* 82(5):1315-1322. doi: 10.2527/2004.8251315x
- Candican Bison Association (CBA): Grading and Labelling of Canadian Bison, 2020. [https://www.canadianbison.ca/application/files/8415/1845/3072/Bison\\_Grading021118.pdf](https://www.canadianbison.ca/application/files/8415/1845/3072/Bison_Grading021118.pdf) Accessed 04 June 2020.
- Chail, A., J. Legako, L. Pitcher, T. Griggs, R. Ward, S. Martini, and J. MacAdam. 2016. Legume finishing provides beef with positive human dietary fatty acid ratios and

consumer preference comparable with grain-finished beef. *Journal of Animal Science* 94

- Chung, K. Y., D. K. Lunt, C. B. Choi, S. H. Chae, R. D. Rhoades, T. H. Adams, B. Booren, and S. B. Smith. 2006. Lipid characteristics of subcutaneous adipose tissue and *M. longissimus thoracis* of Angus and Wagyu steers fed to US and Japanese endpoints. *Meat Science* 73(3):432-441.
- Cordain, L., B. A. Watkins, G. L. Florant, M. Kelher, L. Rogers, and Y. Li. 2002. Fatty acid analysis of wild ruminant tissues: evolutionary implications for reducing diet-related chronic disease. *Eur J Clin Nutr* 56(3):181-191. doi: 10.1038/sj.ejcn.1601307
- Crouse, J. D., H. R. Cross, and S. C. Seideman. 1984. Effects of a Grass or Grain Diet on the Quality of Three Beef Muscles. *Journal of Animal Science* 58(3):619-625.
- Crouse, J. D., and M. Koohmaraie. 1990. Effect of Freezing of Beef on Subsequent Postmortem Aging and Shear Force. *Journal of Food Science* 55(2):573-574.
- Daley, C. A., A. Abbott, P. S. Doyle, G. A. Nader, and S. Larson. 2010. A review of fatty acid profiles and antioxidant content in grass-fed and grain-fed beef. *Nutrition Journal* 9(1):10.
- Dietary Guidelines Advisory Committee 2010. Report of the Dietary Guidelines Advisory Committee on the Dietary Guidelines for Americans. Accessed 23 May, 2020. [https://centerforinquiry.org/wp-content/uploads/sites/33/quackwatch/dga\\_advisory\\_2010.pdf](https://centerforinquiry.org/wp-content/uploads/sites/33/quackwatch/dga_advisory_2010.pdf)

- Dinh, T., J. Blanton, J. Brooks, M. Miller, and D. Thompson. 2008. A simplified method for cholesterol determination in meat and meat products. *Journal of Food Composition and Analysis* 21:306-314. doi: 10.1016/j.jfca.2008.02.001
- Dransfield, E., R. C. Jones, and H. J. Macfie. 1981. Tenderising in *M. longissimus dorsi* of beef, veal, rabbit, lamb and pork. *Meat Sci* 5(2):139-147.
- Duckett, S. K., J. P. Neel, R. M. Lewis, J. P. Fontenot, and W. M. Clapham. 2013. Effects of forage species or concentrate finishing on animal performance, carcass and meat quality. *J Anim Sci* 91(3):1454-1467.
- Duckett, S. K., J. P. Neel, J. P. Fontenot, and W. M. Clapham. 2009. Effects of winter stocker growth rate and finishing system on: III. Tissue proximate, fatty acid, vitamin, and cholesterol content. *J Anim Sci* 87(9):2961-2970.
- Duckett, S. K., J. P. Neel, R. N. Sonon, Jr., J. P. Fontenot, W. M. Clapham, and G. Scaglia. 2007. Effects of winter stocker growth rate and finishing system on: II. Ninth-tenth-eleventh-rib composition, muscle color, and palatability. *J Anim Sci* 85(10):2691-2698.
- Duckett, S. K., D. G. Wagner, L. D. Yates, H. G. Dolezal, and S. G. May. 1993. Effects of time on feed on beef nutrient composition. *J Anim Sci* 71(8):2079-2088.
- Ekeren, P. A., D. R. Smith, D. K. Lunt, and S. B. Smith. 1992. Ruminant biohydrogenation of fatty acids from high-oleate sunflower seeds. *Journal of animal science* 70(8):2574-2580.
- Eichhorn, J. M., L. J. Coleman, E. J. Wakayama, G. J. Blomquist, C. M. Bailey, and T. G. Jenkins. 1986. Effects of breed type and restricted versus ad libitum feeding on

fatty acid composition and cholesterol content of muscle and adipose tissue from mature bovine females. *J Anim Sci* 63(3):781-794.

Elmore, J. S., H. E. Warren, D. S. Mottram, N. D. Scollan, M. Enser, R. I. Richardson, and J. D. Wood. 2004. A comparison of the aroma volatiles and fatty acid compositions of grilled beef muscle from Aberdeen Angus and Holstein-Friesian steers fed diets based on silage or concentrates. *Meat Science* 68(1):27-33.

Enser, M. 2001. The role of fats in human nutrition. In B. Rossell (Ed), *Oils and fats Vol 2. Animal carcass fats* (pp. 77-122). Leatherhead, Surrey, UK: Leatherhead Publishing.

Enser, M., K. G. Hallett, B. Hewett, G. A. J. Fursey, J. D. Wood, and G. Harrington. 1998. Fatty acid content and composition of UK beef and lamb muscle in relation to production system and implications for human nutrition. *Meat Science* 49(3):329-341.

Fishell, V. K., E. D. Aberle, M. D. Judge, and T. W. Perry. 1985. Palatability and Muscle Properties of Beef as Influenced by Preslaughter Growth Rate. *Journal of Animal Science* 61(1):151-157.

French, P., E. G. O'Riordan, F. J. Monahan, P. J. Caffrey, M. T. Mooney, D. J. Troy, and A. P. Moloney. 2001. The eating quality of meat of steers fed grass and/or concentrates. *Meat Sci* 57(4):379-386. doi: 10.1016/s0309-1740(00)00115-7

French, P., C. Stanton, F. Lawless, E. G. O'Riordan, F. J. Monahan, P. J. Caffrey, and A. P. Moloney. 2000. Fatty acid composition, including conjugated linoleic acid, of

- intramuscular fat from steers offered grazed grass, grass silage, or concentrate-based diets. *J Anim Sci* 78(11):2849-2855.
- Galbraith J.K. 2011. Meat characteristics and stress of bison slaughtered in a mobile or stationary abattoir. Ph.D. dissertation. University of Alberta, Edmonton, Alberta.
- Hall, J. B., and M. C. Hunt. 1982. Collagen Solubility of A-Maturity Bovine Longissimus Muscle as affected by Nutritional Regimen. *Journal of Animal Science* 55(2):321-328.
- Hawley, A.W.L. 1986. Carcass Characteristics of bison (*Bison bison*) steers. *Canadian Journal of Animal Science*. 66:293.
- Hildrum, K. I., M. Solvang, B. N. Nilsen, T. Frøystein, and J. Berg. 1999. Combined effects of chilling rate, low voltage electrical stimulation and freezing on sensory properties of bovine *M. longissimus dorsi*. *Meat Sci* 52(1):1-7.
- Hiner, R. L., L. L. Madsen, and O. G. Hankins. 1945. Histological characteristics, tenderness, and drip losses of beef in relation to temperature of freezing. *Journal of Food Science* 10(4):312-324.
- Huff, E. J. 1993. Bovine longissimus muscles tenderness as affected by postmortem aging time, animal age and sex. *Journal of food science* v. 58(no. 4):pp. 713-716-1993 v.1958 no.1994.
- Huff-Lonergan, E., T. Mitsuhashi, D. D. Beekman, F. C. Parrish, D. G. Olson, and R. M. Robson. 1996. Proteolysis of specific muscle structural proteins by mu-calpain at low pH and temperature is similar to degradation in postmortem bovine muscle. *Journal of Animal Science* 74(5):993.
- Igene, J. O., A. M. Pearson, L. R. Dugan, and J. F. Price. 1980. Role of triglycerides and

- phospholipids on development of rancidity in model meat systems during frozen storage. *Food Chemistry* 5(4):263-276.
- Keller, J., and J. Kinsella. 2006. Phospholipid changes and lipid oxidation during cooking and frozen storage of ground beef. *Journal of Food Science* 38:1200-1204.
- Koch, R. M., H.G. Jung, J. D. Crouse, V. H. Varel, & L. V. Cundiff. 1995. Growth, digestive capability, carcass, and meat characteristics of *Bison bison*, *Bos taurus*, and *Bos x Bison*. *Journal of Animal Science*. 73, 1271-1281.
- Koohmaraie, M., S. C. Seideman, J. E. Schollmeyer, T. R. Dutson, and J. D. Crouse. 1987. Effect of postmortem storage of Ca<sup>2+</sup>- dependent proteases, their inhibitor and myofibril fragmentation. *Meat Sci*. 19:187.
- Larick, D., B. Turner, R. Koch, and J. Crouse. 1989. Influence of Phospholipid Content and Fatty Acid Composition of Individual Phospholipids in Muscle from Bison, Hereford and Brahman Steers on Flavor. *Journal of Food Science* 54:521-526.
- Larick, D. K., H. B. Hedrick, M. E. Bailey, J. E. Williams, D. L. Hancock, G. B. Garner, and R. E. Morrow. 1987. Flavor Constituents of Beef as Influenced by Forage- and Grain-Feeding. *Journal of Food Science* 52(2):245-251.
- Law, H. M., S. P. Yang, A. M. Mullins, and M. M. Fielder. 1967. Effect of Storage and Cooking on Qualities of Loin and Top-Wound Steaks. *Journal of Food Science* 32(6):637-641.
- Leheska, J. M., L. D. Thompson, J. C. Howe, E. Hentges, J. Boyce, J. C. Brooks, B. Shriver, L. Hoover, and M. F. Miller. 2008. Effects of conventional and grass-feeding systems on the nutrient composition of beef<sup>1</sup>. *Journal of Animal Science* 86(12):3575-3585.



- Li, D., S. Siriamornpun, M. L. Wahlqvist, N. J. Mann, and A. J. Sinclair. 2005. Lean meat and heart health. *Asia Pac J Clin Nutr* 14(2):113-119.
- Lochner, J. V., R. G. Kauffman, and B. B. Marsh. 1980. Early-postmortem cooling rate and beef tenderness. *Meat Science* 4(3):227-241.
- Lopez-Campos, f., J. L. Aalhus, J. Galbraith, I. L. Larsen, M. Juarez, B. Uttaro, and W. M. Robertson. 2014. The relation of carcass physiological maturity to meat quality in the Canadian Bison Grading System. *Canadian journal of plant science* 94(1):55-62
- Marchello, M. J., and J. A. Driskell. 2001. Nutrient Composition of Grass- and Grain-Finished Bison. *Great Plains Research* 11:65-82.
- Marchello, M. J., W. D. Slinger, M. Hadley, D. B. Milne, and J. A. Driskell. 1998. Nutrient Composition of Bison Fed Concentrate Diets. *Journal of Food Composition and Analysis* 11(3):231-239.
- Marchello, M. J., W. D. Slinger, D. B. Milne, A. G. Fischer, and P. T. Berg. 1989. Nutrient composition of raw and cooked Bison bison. *Journal of Food Composition and Analysis* 2(2):177-185.
- Maughan, C., R. Tansawat, D. Cornforth, R. Ward, and S. Martini. 2012. Development of a beef flavor lexicon and its application to compare the flavor profile and consumer acceptance of rib steaks from grass- or grain-fed cattle. *Meat Sci* 90(1):116-121.
- McIntyre, B. L.; Ryan, W. J. 1984: The influence of type of diet and electrical stimulation on the eating quality of beef. *Animal production in Australia* 75:468-471.

- Medeiros, L. C., R. A. Field, D. J. Menkhaus, and W. C. Russel. 1987. Evaluation of range-grazed and concentrate-fed beef by a trained sensory panel, a household panel and a laboratory test market group. *J. Sens. Stud.* 2:259–272.
- Melton, S. L. 1990. Effects of feeds on flavor of red meat: a review. *J Anim Sci* 68(12):4421-4435.
- Miller, M., M. Carr, C. Ramsey, K. Crockett, and L. Hoover. 2002. Consumer thresholds for establishing the value of beef tenderness. *Journal of animal science* 79:3062-3068. doi: 10.2527/2001.79123062x
- Mills, E. W., J. W. Comerford, R. Hollender, H. W. Harpster, B. House, and W. R. Henning. 1992. Meat composition and palatability of Holstein and beef steers as influenced by forage type and protein source. *Journal of animal science* 70(8):2446-2451.
- Mohrhauser, D. A., A. R. Taylor, M. G. Gonda, K. R. Underwood, R. H. Pritchard, A. E. Wertz-Lutz, and A. D. Blair. 2015. The influence of maternal energy status during mid-gestation on beef offspring tenderness, muscle characteristics, and gene expression. *Meat Science* 110:201-211.
- Morgan, J. B., J. W. Savell, D. S. Hale, R. K. Miller, D. B. Griffin, H. R. Cross, and S. D. Shackelford. 1991. National beef tenderness survey. *J Anim Sci* 69(8):3274-3283.
- Morris, E. A., Witkind, W. M., Dix, R. L. and Jacobson, J. 1981. Nutritional content of selected aboriginal foods in northeastern Colorado: buffalo (*Bison bison*) and wild onions (*Allium* spp.). *J. Ethnobiol.* 1: 213220.
- Morris, S. T., Purchas, R. W. Burnham, D. L. 1997. Short-term grain feeding and its

- effect on carcass and meat quality. *Proceedings of the New Zealand Society of Animal Production* 57:275-277.
- Muir, P. D., J. M. Deaker, and M. D. Bown. 1998. Effects of forage- and grain-based feeding systems on beef quality: A review. *New Zealand Journal of Agricultural Research* 41(4):623-635.
- National Bison Association (NBA). 2020. Current Status. Accessed 24 July, 2020  
<https://bisoncentral.com/current-status/>
- National Bison Association (NBA). 2018. Bullish on Bison. Accessed 23 May, 2020  
<https://bisoncentral.com/wp-content/uploads/2018/07/Bullish-on-Bison-7-19.pdf>
- Neel, J. P., J. P. Fontenot, W. M. Clapham, S. K. Duckett, E. E. Felton, G. Scaglia, and W. B. Bryan. 2007. Effects of winter stocker growth rate and finishing system on: Animal performance and carcass characteristics. *J Anim Sci* 85(8):2012-2018.
- O'Quinn, T. G., D. R. Woerner, T. E. Engle, P. L. Chapman, J. F. Legako, J. C. Brooks, K. E. Belk, and J. D. Tatum. 2016. Identifying consumer preferences for specific beef flavor characteristics in relation to cattle production and postmortem processing parameters. *Meat Sci* 112:90-102.
- Owens, F., and B. Gardner. 2000. A review of the impact of feedlot management and nutrition on carcass measurements of feedlot cattle. *J Anim Sci* 77.
- Parrish, F. C., Jr., R. B. Young, B. E. Miner, and L. D. Anderson. 1973. Effects of postmortem condition on certain chemical, morphological and organoleptic properties of bovine muscle. *J. Food Sci.* 38:690.
- Parrish, F. C., Jr., J. A. Boles, R. E. Rust, D. G. Olson. 1991. Dry and wet aging effects on

- palatability attributes of beef loin and rib steaks from three quality grades. *J. Food Sci.* 56W-603.
- Pearson, A. M., and J. I. Miller. 1950. The Influence of Rate of Freezing and Length of Freezer-Storage upon the Quality of Beef of Known Origin. *Journal of Animal Science* 9(1):13-19.
- Reagan, J. O., J. A. Carpenter, F. T. Bauer, and R. S. Lowrey. 1977. Packaging and palatability characteristics of grass and grassgrain fed beef. *J. Anim. Sci.* 45:716–721 and Meat Quality (In press). Audet Tejdschriften bv, Nijmegen, The Netherlands.
- Robson, R. M., J. M. O’Shea, M. K. Hartzler, W. E. Rathbun, F. LaSalle, P. J. Schreiner, L. E. Kasang, M. H. Stromer, M. L. Lusby, J. F. Ridpath, Y.-Y. Pang, R. R. Evans, M. G. Zeece, F. C. Parrish, Jr., and T. W. Huiatt. 1984. Role of new cytoskeletal elements in maintenance of muscle integrity. *J. Food Biochem.* 8:1.
- Rule, D.C., K.S. Broughton, S.M. Shellito, and G. Mariorano. 2002. Comparison of muscle fatty acid profiles and cholesterol concentrations of bison, beef, elk, and chicken. *Journal of Animal Science*, 80, 1202-1211.
- Savell, J., and H. Cross. 1988. The role of fat in the palatability of beef, pork, and lamb. *Designing Foods: Animal Product Options in the Marketplace, Committee on Technological Options to Improve the Nutritional Attributes of Animal Products.* National Academy Press Washington DC. p. 345-355.
- Savell, J. W., H. R. Cross, and G. C. Smith. 1986. Percentage Ether Extractable Fat and Moisture Content of Beef Longissimus Muscle as Related to USDA Marbling Score. *Journal of Food Science* 51(3):838-839

- Scollen, N., J.P. Hocquette, K. Nuernberg, D. Danneberger, L. Richardson, and A. Molony. 2006. Innovations in beef production systems that enhance the nutritional and health value of beef lipids and their relationship with meat quality. *Meat Science*, 74, 17-33.
- Simopoulos, A. P. 2004. Omega6/Omega3 Essential Fatty Acid Ratio and Chronic Diseases. *Food Reviews International - Food Rev Int* 20:77-90.
- Shanks, B., D. Wulf, and R. Maddock. 2002. Technical note: The effect of freezing on Warner-Bratzler shear force values of beef longissimus steaks across several postmortem aging periods<sup>1</sup>. *Journal of Animal Science* 80:2122-2125.
- Shimokomaki, M., D. F. Elsdon, and A. J. Bailey. 1972. Meat tenderness: age related changes in bovine intramuscular collagen. *Journal of Food Science* 37(6):892-896.
- Smith, S. B., D. K. Lunt, K. Y. Chung, C. B. Choi, R. K. Tume, and M. Zembayashi. 2006. Adiposity, fatty acid composition, and delta-9 desaturase activity during growth in beef cattle. *Animal Science Journal* 77(5):478-486
- Smith, S. B., A. Yang, T. W. Larsen, and R. K. Tume. 1998. Positional analysis of triacylglycerols from bovine adipose tissue lipids varying in degree of unsaturation. *Lipids* 33(2):197-207.
- Smith, G. C., T. R. Dutson, R. L. Hostetler, and Z. L. Carpenter. 1976. Fatness, rate of chilling and tenderness of lamb. *Journal of Food Science* 41(4):748-756.
- Smith, G. C., Z. L. Carpenter, and G. T. King. 1969. Considerations for Beef Tenderness Evaluations. *Journal of Food Science* 34(6):612-618.
- Smith, G. C., C. W. Spaeth, Z. L. Carpenter, G. T. King, and K. E. Hoke. 1968. The

- Effects of Freezing, Frozen Storage Conditions and Degree of Doneness on Lamb Palatability Characteristics. *Journal of Food Science* 33(1):19-24.
- Spronk, J.L., D.M. Wulf, B.W. Anderson, A.C. Kulowski, B.A. Streff, A.M. Gensmer, R.J. Maddock. Year Unknown. Estimates of Meat Product Yields from Bison Carcasses. South Dakota State University; Meat Science.
- Sweeten, M. K., H. R. Cross, G. C. Smith, J. W. Savell, and S. B. Smith. 1990. Lean beef: impetus for lipid modifications. *J Am Diet Assoc* 90(1):87-92.
- Tansawat, R., C. A. J. Maughan, R. E. Ward, S. Martini, and D. P. Cornforth. 2013. Chemical characterisation of pasture- and grain-fed beef related to meat quality and flavour attributes. *International Journal of Food Science & Technology* 48(3):484-495.
- USDA-AMS Grain and Livestock Market Reporting Service. Accessed 18 June, 2019.
- USDA Monthly Bison Report, Carcass and Cuts  
[https://www.ams.usda.gov/mnreports/nw\\_ls526.txt](https://www.ams.usda.gov/mnreports/nw_ls526.txt)
- USDA Beef Carcass Price Equivalent Index Value  
[https://www.ams.usda.gov/mnreports/nw\\_ls410.txt](https://www.ams.usda.gov/mnreports/nw_ls410.txt)
- USAA-AMS Livestock, Poultry, and Seed Program. United States Standards for Grades of Carcass Beef. 2017. Accessed 09 June, 2020.  
<https://www.ams.usda.gov/sites/default/files/media/CarcassBeefStandard.pdf>
- Van Elswyk, M. E., and S. H. McNeill. 2014. Impact of grass/forage feeding versus grain finishing on beef nutrients and sensory quality: the U.S. experience. *Meat Sci* 96(1):535-540.
- Varnam, A. H., & Sutherland, J. P. 1995. The colour of meat. In *Meat and meat products*

- technology, chemistry and micro biology(p. 26). Chapman and Hall: London.
- Voet, D., J. G. Voet, and C. W. Pratt. 2006. Fundamentals of Biochemistry - Life at the Molecular Level. 2nd ed. John Wiley & Sons Inc., New York, NY.
- Wahrmund-Wyle, J. L., K. B. Harris, and J. W. Savell. 2000. Beef Retail Cut Composition: 2. Proximate Analysis. *Journal of Food Composition and Analysis* 13(3):243-251.
- Waldman, R. C., G. G. Suess, and V. H. Brungardt. 1968. Fatty Acids of Certain Bovine Tissue and Their Association with Growth, Carcass and Palatability Traits. *Journal of Animal Science* 27(3):632-635.
- Westerling, D. B., and H. B. Hedrick. 1979. Fatty acid composition of bovine lipids as influenced by diet, sex and anatomical location and relationship to sensory characteristics. *J. Anim. Sci.* 48:1343-1348.
- Wood, J. D., R. I. Richardson, G. R. Nute, A. V. Fisher, M. M. Campo, E. Kasapidou, P. R. Sheard, and M. Enser. 2004. Effects of fatty acids on meat quality: a review. *Meat Science* 66(1):21-3





**Table 2-1.** Least squares means for effect of finishing system on live weight and carcass characteristics of grain- or grass-finished bison heifers.

Variable	GRAIN <sup>1</sup>	GRASS <sup>1</sup>	SEM <sup>2</sup>	P-value <sup>3</sup>
Live Weight, kg	445.93	378.40	2.962	<.0001
Hot carcass weight, kg	281.43	226.42	2.285	<.0001
Dressing Percentage, %	63.09	59.81	0.234	<.0001
Ribeye area, cm <sup>2</sup>	64.58	57.48	0.768	<.0001
Back fat thickness, cm	2.16	0.89	0.084	<.0001
Kidney, pelvic, and heart fat, %	2.56	0.87	0.069	<.0001
Marbling score <sup>4</sup>	389.35	243.67	9.924	<.0001
Yield Grade <sup>5</sup>				
YG 2	5.56	55.91	5.148	.0965
YG 3	29.63	19.35	4.394	.3435
YG 4	46.30	3.23	4.798	.1195
Skeletal Maturity <sup>6</sup>				
Extreme Hardbone (>100%)	7.71	6.25	6.140	.6655
Hardbone (50-99%)	28.69	17.19	4.771	.0582
Moderate (25-49%)	36.84	29.90	8.118	.3033
Slight (0-24%)	24.32	44.88	8.617	.0031
Lean Maturity <sup>6</sup>				
Pale Red	0.74	9.97	7.883	.0116
Red	5.56	24.73	4.474	.1746
Slightly Bright Red	19.44	22.58	4.336	.6824
Moderately Bright Red	32.41	30.11	4.757	.7854
Bright Red	41.64	7.49	6.377	<.0001
Subjective External Fat Color <sup>7</sup>				
Moderately Yellow	1.84	52.67	6.593	<.0001
Slightly White	7.41	24.73	4.474	.1918
Moderately White	64.89	4.23	34.960	<.0001

<sup>1</sup>Treatments; GRAIN = bison heifers (n=108) backgrounded on grain and finished for 130 days with ad libitum access to grass hay, alfalfa, and a corn and dry distiller's grain concentrate prior to slaughter. GRASS = bison heifers (n=93) remained on pasture until slaughter

<sup>2</sup>Standard error of the mean

<sup>3</sup>Probability of difference among least square means

<sup>4</sup>Marbling score: 100=Practically Devoid<sup>0</sup>, 200=Traces<sup>0</sup>, 300=Slight<sup>0</sup>, 400=Small<sup>0</sup>

<sup>5</sup>Yield Grade calculated according to USDA beef grading system; GLIMMIX analysis failed to converge for USDA Yield Grade 1 (n =20) or 5 (n = 20).

<sup>6</sup>Skeletal maturity and lean maturity assigned by USDA. GLIMMIX analysis failed to converge for Lean Maturity category 'dark cutter' (n=3)

<sup>7</sup>Subjective External Fat Color assigned by USDA. GLIMMIX analysis failed to converge for Yellow (n=13) or White (n=34) categories.

**Table 2-2.** Least squares means for effect of finishing system on objective color measurements and ultimate pH of grain- or grass-finished bison heifers.

Variable	GRAIN <sup>1</sup>	GRASS <sup>1</sup>	SEM <sup>2</sup>	P-value <sup>3</sup>
Objective Color <sup>4</sup>				
L*	37.56	36.62	0.189	<.0001
a*	25.20	23.21	0.195	<.0001
b*	9.84	8.62	0.127	<.0001
Objective Color <sup>5</sup>				
L*	74.00	77.20	0.429	<.0001
a*	4.32	2.90	0.166	<.0001
b*	14.51	21.92	0.336	<.0001
Ultimate pH <sup>6</sup>	5.58	5.59	0.016	.8051

<sup>1</sup>Treatments; GRAIN = bison heifers (n=108) backgrounded on grain and finished for 130 days with ad libitum access to grass hay, alfalfa, and a corn and dry distiller's grain concentrate prior to slaughter. GRASS = bison heifers (n=93) remained on pasture until slaughter

<sup>2</sup>Standard error of the mean

<sup>3</sup>Probability of difference among least square means

<sup>4</sup>Objective color measurement recorded on the exposed ribeye following an approximately 30 min bloom time; L\*: 0 = Black, 100 = White; a\*: Negative values = green; Positive values = red; b\*: Negative values = blue; Positive values = yellow

<sup>5</sup>Objective color measurement of subcutaneous fat recorded on the external surface of the carcass, opposite the ribeye; L\*: 0 = Black, 100 = White; a\*: Negative values = green; Positive values = red; b\*: Negative values = blue; Positive values = yellow

<sup>6</sup>Ultimate pH was measured on at either 2 or 3 d postmortem from grain- (n=30) and grass- (n=30) finished striploins

**Table 2-3.** Least square means for the effect of finishing treatment on the proximate nutrient composition of raw tissue from the *longissimus dorsi* of grain- or grass-finished bison heifers

Nutrient	GRAIN <sup>1</sup>	GRASS <sup>1</sup>	SEM <sup>2</sup>	P-value <sup>3</sup>
Moisture, %	74.05	75.94	0.239	<.0001
Protein, %	21.39	21.00	0.166	.0221
Fat, %	3.21	1.94	0.227	<.0001
Ash, %	1.08	1.09	0.010	.2208
Cholesterol, (mg/100g)	54.31	51.41	1.043	.0073

<sup>1</sup>Treatments; GRAIN = bison heifers (n=30) backgrounded on pasture and finished for 130 days with ad libitum access to grass hay, alfalfa, and a corn and dry distiller's grain concentrate prior to slaughter. GRASS = bison heifers (n=29) remained on pasture until slaughter

<sup>2</sup>Standard error of the mean

<sup>3</sup>Probability of difference among least square means

**Table 2-4.** Least square means for the effect of finishing treatment on the fatty acid composition of raw tissue from bison *longissimus dorsi* of **grain- or grass-finished bison heifers.**

Fatty Acids	GRAIN <sup>1</sup>	GRASS <sup>1</sup>	SEM <sup>2</sup>	P-Value <sup>3</sup>
---- Fatty acid concentrations (mg/g wet sample basis) ----				
C10:0	0.02	0.01	0.003	.0344
C12:0	0.02	0.02	0.002	.2322
C14:0	0.49	0.31	0.033	<.0001
C14:1n5	0.13	0.11	0.008	.0057
C15:0	0.15	0.12	0.009	.0013
C16:0	5.78	3.38	0.428	<.0001
C16:1trans	0.11	0.11	0.010	.8680
C17:0	0.38	0.23	0.032	<.0001
C17:1	0.36	0.17	0.044	<.0001
C18:0	3.85	2.71	0.285	.0002
C20:0	0.09	0.26	0.012	<.0001
C18:1n9	14.19	7.34	1.047	<.0001
C18:1 trans	0.25	0.21	0.019	.0771
C18:1n7*	-----	-----	-----	-----
C24:1n9	0.19	0.14	0.027	.0512
C18:2trans	0.08	0.07	0.006	.1741
C18:2n6	1.72	1.27	0.059	<.0001
C18:3n3	0.25	0.27	0.017	.1500
C18:3n6*	-----	-----	-----	-----
C20:2	0.09	0.08	0.014	.6545
C20:3n6	0.05	0.05	0.010	.9112
C20:4n6	0.69	0.58	0.031	.0009
C22:3	0.16	0.15	0.016	.3935
C22:5n3	0.45	0.55	0.026	.0008
C22:6n3	0.61	0.59	0.099	.8703
TOTAL	30.97	19.07	1.984	<.0001
SFA	10.80	7.03	0.780	<.0001
MUFA	16.07	8.42	1.159	<.0001
PUFA	4.11	3.62	0.196	.0155
PUFA:SFA	0.41	0.58	0.046	.0006
n-6:n-3 ratio	5.74	4.64	0.201	<.0001
----Fatty acid percentages (% , g/100g total fatty acids) ----				
C10:0	0.06	0.07	0.010	.3869
C12:0	0.08	0.12	0.012	.0020
C14:0	1.58	1.63	0.045	.2631
C14:1n5	0.43	0.60	0.031	<.0001
C15:0	0.49	0.64	0.030	<.0001
C16:0	18.57	17.27	0.482	.0092
C16:1trans	0.36	0.57	0.014	<.0001

**Table 2-4 Continued.** Least square means for the effect of finishing treatment on the fatty acid composition of raw tissue from bison *longissimus dorsi* of grain- or grass-finished bison heifers.

C17:0	1.21	1.17	0.042	.3380
C17:1	1.12	0.85	0.116	.0225
C18:0	12.35	14.11	0.347	<.0001
Fatty Acids	GRAIN <sup>1</sup>	GRASS <sup>1</sup>	SEM <sup>2</sup>	P-Value <sup>3</sup>
C20:0	0.33	1.42	0.070	<.0001
C18:1n9	45.60	37.38	0.925	<.0001
C18:1 trans	0.81	1.14	0.041	<.0001
C18:1n7*	-----	-----	-----	-----
C24:1n9	0.60	0.80	0.114	.0791
C18:2trans	0.24	0.38	0.015	<.0001
C18:2n6	5.94	7.24	0.457	.0064
C18:3n3	0.86	1.55	0.117	<.0001
C18:3n6*	-----	-----	-----	-----
C20:2	0.26	0.47	0.026	<.0001
C20:3n6	0.14	0.30	0.028	<.0001
C20:4n6	2.32	3.33	0.220	<.0001
C22:3	0.51	0.85	0.063	<.0001
C22:5n3	1.58	3.10	0.192	<.0001
C22:6n3	1.82	3.28	0.333	<.0001
SFA	34.66	36.39	0.732	.0219
MUFA	51.58	43.07	0.963	<.0001
PUFA	13.75	20.53	1.219	<.0001

\*Fatty acids present in minimal amounts that were undetected by gas chromatography analysis

<sup>1</sup>Treatments; GRAIN = bison heifers (n=30) backgrounded on pasture and finished for 130 days with ad libitum access to grass hay, alfalfa, and a corn and dry distiller's grain concentrate prior to slaughter.

GRASS = bison heifers (n=29) remained on pasture until slaughter

<sup>2</sup>Standard error of the mean

<sup>3</sup>Probability of difference among least square means

**Table 2-5.** Least squares means for effect of storage conditions on tenderness of striploin steaks from grain- and grass-finished bison

Variable	FRESH <sup>1</sup>	FROZEN <sup>1</sup>	SEM <sup>2</sup>	<i>P</i> -value <sup>3</sup>
WBSF, kg <sup>5</sup>	3.24	2.72	0.526	<.0001
Cook loss, % <sup>6</sup>	20.71	22.67	0.356	0.0001

<sup>1</sup>Treatments; FRESH = striploin steaks (n=60) from grain- and grass-finished bison heifers, aged 14 d, and kept in fresh storage conditions prior to analysis. FROZEN = striploin steaks (n=60) from grain- and grass-finished heifers, aged 14 d kept in frozen storage conditions ~3 months prior to analysis.

<sup>3</sup>Standard error of the mean

<sup>4</sup>Probability of difference among least square means

<sup>5</sup>Kg of force measured by texture analyzer with a Warner Bratzler Shear Force attachment, analyzed for the main effect of storage treatment.

<sup>6</sup>Percent of weight loss after cooking.

**Table 2-6.** Least square means for the effect of finishing treatment on subjective meat quality attributes rated by a consumer sensory panel (n=113 participants).

Attribute <sup>1</sup>	GRAIN <sup>2</sup>	GRASS <sup>2</sup>	SEM <sup>3</sup>	<i>P</i> -value <sup>4</sup>
Overall liking	80.39	78.48	1.657	.2591
Aroma liking	76.99	75.31	1.853	.3756
Flavor liking	79.12	77.68	1.840	.4426
Texture liking	79.88	77.23	2.212	.2440
Toughness	6.64	7.32	0.519	.2073
Juiciness	8.91	9.42	0.556	.3693
Off-flavor	3.65	4.21	0.409	.1861

<sup>1</sup>Liking ratings were made on 0-120-point labeled affective magnitude scales, with the left most end (score of 0) labeled greatest imaginable disliking and the right most end (score of 120) labeled greatest imaginable liking.

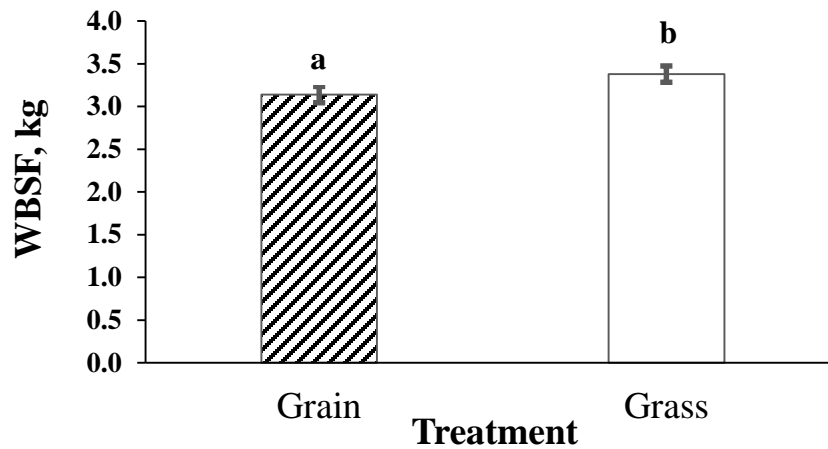
Intensity ratings were made on 0-20-point line scales with the left most ends labeled none (score of 0) and the right most ends labeled extremely intense for off flavor, extremely tough, or extremely juicy (score of 20)

<sup>2</sup>Treatments; GRAIN = bison heifers backgrounded on pasture and finished for 130 days with ad libitum access to grass hay, alfalfa, and a corn and dry distiller's grain concentrate prior to slaughter. GRASS = bison heifers remained on pasture until slaughter

<sup>3</sup>Standard error of the mean

<sup>4</sup>Probability of difference among least square means

**Figure 2-1.** Least square means for the effect of finishing system on tenderness of bison striploin steaks.

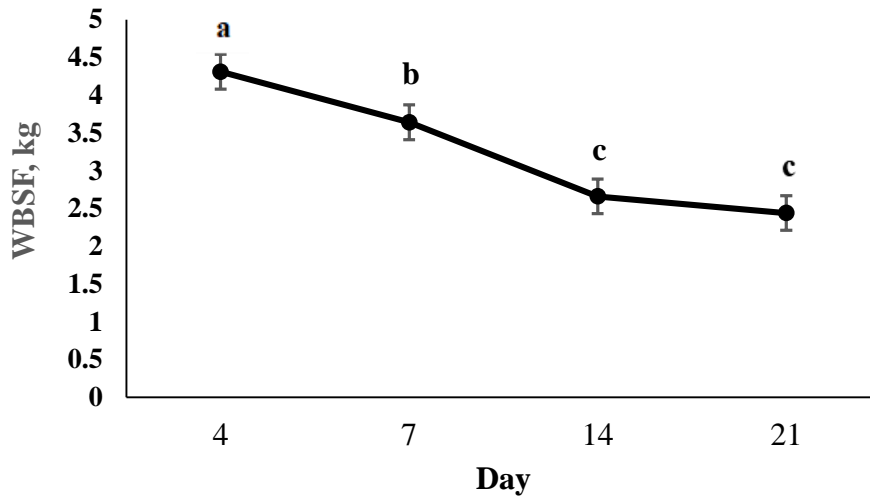


Treatments; GRAIN = bison heifers (n=30) backgrounded on pasture and finished for 130 days with ad libitum access to grass hay, alfalfa, and a corn and dry distiller's grain concentrate prior to slaughter. GRASS = bison heifers (n=30) remained on pasture until slaughter. All steaks were stored frozen prior to analysis.

Means <sup>a,b</sup> lacking a common superscript differ  $P < 0.05$ .

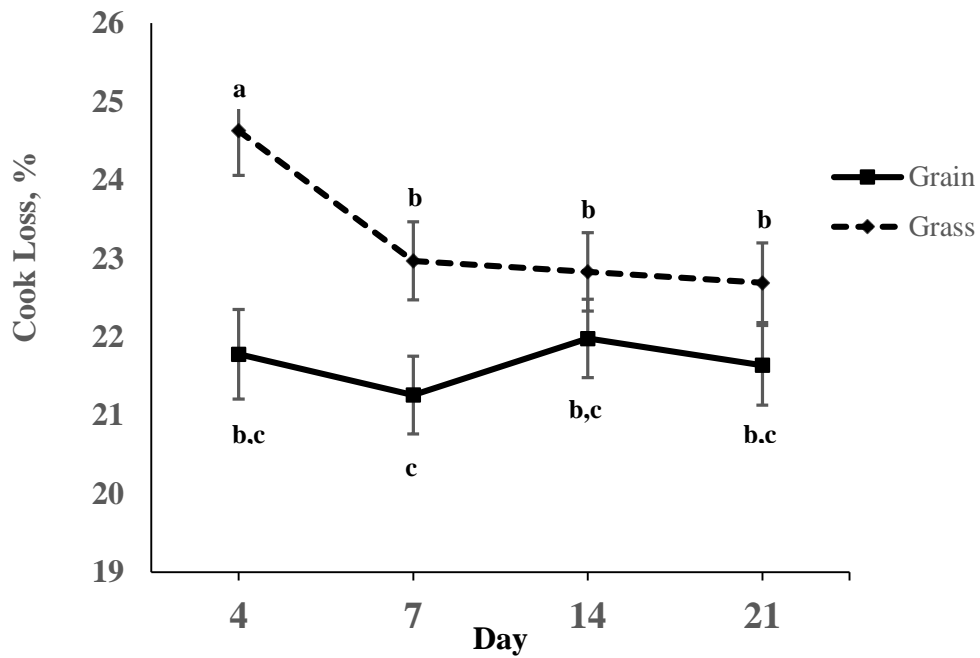


**Figure 2-2.** Least square means for the effect of postmortem aging on tenderness of bison striploin steaks. All steaks stored frozen prior to analysis.



Treatments; GRAIN = bison heifers (n=30) backgrounded on pasture and finished for 130 days with ad libitum access to grass hay, alfalfa, and a corn and dry distiller's grain concentrate prior to slaughter. GRASS = bison heifers (n=30) remained on pasture until slaughter. Means <sup>a,b</sup> lacking a common superscript differ  $P < 0.05$ .

**Figure 2-3.** Least square means of cook loss for the interaction of days postmortem aged and finishing system effects on bison striploin steaks.



Treatments: Steaks aged for 4 (n=60), 7 (n=60), 14 (n=60), and 21 (n=60) days postmortem from both grain-finished bison heifers (backgrounded on pasture and finished for 130 days with ad libitum access to grass hay, alfalfa, and a corn and dry distiller's grain concentrate prior to slaughter), and grass-finished bison heifers (remained on pasture until slaughter). All steaks were stored frozen prior to analysis. Means <sup>a,b</sup> lacking a common superscript differ  $P < 0.05$ .

## CHAPTER 3: A TECHNICAL NOTE: UTILIZATION OF CAMERA GRADING TECHNOLOGY FOR BISON CARCASS CHARACTERISTICS

### **Abstract**

The objective of this study was to evaluate the effectiveness of beef camera grading technology on bison carcass characteristics. Bison heifers were randomly assigned to finishing treatments: Grain-finished (n=108; backgrounded on pasture and finished for 130 d with ad libitum access to grass hay, alfalfa, and a corn and dry distiller's grain concentrate prior to slaughter) or Grass-finished (n=93; remained on pasture until slaughter). Heifers were transported (~720 km) to a commercial packing facility and slaughtered at 28 mo of age over a 2-d period. Carcass measurements and camera images were collected at ~20 h postmortem. Carcasses were ribbed between the 12<sup>th</sup> and 13<sup>th</sup> rib and allowed to bloom for approximately 30 m. An expert USDA grader evaluated ribeye area, backfat thickness, and marbling score of one side of each carcass. USDA personnel then captured images of the exposed ribeye from the same side evaluated by the grader using the hand-held camera portion of a VBG2000 image processing system. The system automatically determined carcass parameters from the images, including preliminary yield grade, yield grade, ribeye area, and marbling. To assess the ability of the beef grading camera to evaluate bison carcass characteristics, both camera and grader measurements were analyzed using the MIXED procedures of SAS (SAS Inst. Inc., Cary NC), while yield grade data was analyzed using the GLIMMIX procedures for the main effect of finishing treatment; slaughter date was included as a random effect. Separation of least-squares main effect means was performed using LSD with a Tukey's adjustment, assuming  $\alpha=0.05$ . Additionally,

correlations between grader and camera measurements were analyzed using the CORR procedures of SAS. Grain-finished bison heifers had increased ( $P < .0001$ ) backfat thickness and marbling scores compared to grass-finished carcasses when evaluated by both the camera and expert grader. Across both finishing treatments, means for ribeye area and marbling were increased, while mean backfat thickness was decreased when evaluated by the camera in comparison to the expert grader. Regardless of evaluation by camera or grader, yield grade was not impacted ( $P > .1000$ ) by finishing system, with the exception of increased ( $P < .0001$ ) proportion of yield grade 1 carcasses in the grass-finished treatment when evaluated by the camera, and a tendency for increased ( $P = .0965$ ) proportion of yield grade 2 in the grass-finished treatment when evaluated by the expert grader. Correlations were positive ( $P < .0001$ ) between expert grader and camera measurements for yield grade, back fat thickness, and ribeye area. Correlations between the camera and grader were highest ( $R = .978$ ,  $P < .0001$ ) for yield grade, and lowest ( $R = .451$ ,  $P < .0001$ ) for marbling score measurements. Additional camera measurements identified as unknown pixels were found to be positively correlated ( $R = .621$ ,  $P < .0001$ ) with camera ribeye area evaluations, but not correlated ( $R = .002$ ,  $P = .9807$ ) with camera marbling evaluations. Collectively, this data indicates bison ribeye images collected with a beef grading camera were correlated with expert grader evaluations. However, accuracy of measurements and validation of a suitable camera grading system for bison will require additional investigation, including calibration and adjustments for bison carcass characteristics.

## Introduction

Multiple instrument technologies have been evaluated for the assessment of beef yield and quality traits in the interest of establishing and improving a true value-based marketing system for beef (Belk and Woerner 2008). Instrument grading technology was first approved for use in determining the size of beef ribeye areas in 2001, followed by use for yield grades in 2007, and marbling in 2009 (USDA-AMS, 2017). Yield grades estimate the amount of boneless, closely trimmed retail cuts from the high-value parts of the carcass, including the round, loin, rib, and chuck (Hale et al., 2013). Beef quality grades are intended to predict palatability and include measures of animal maturity (skeletal ossification or dentition) and marbling within the ribeye. Implementation of instrument technology has benefited the beef industry by allowing beef processors to efficiently collect detailed carcass data that can be provided to beef producers and other stakeholders within the industry.

Production and consumption of bison (*bison bison*) has increased significantly since they were hunted to near extinction in North America during the late 1800's (Marchello and Driskell 2001). Currently it is estimated that there are approximately 400,000 bison in North America (including private, state, federal, and tribal herds; National Bison Association: Current Status, 2020). However, there is a limited amount of research investigating carcass characteristics of bison, as there is no established yield or quality grading system in the United States, which limits opportunities to expand markets. Further, producers utilize different finishing systems (grain- and grass-finishing), which lends to product variation. Therefore, the objective of this study was to

evaluate the ability of beef camera grading technology to assess carcass characteristics of grain- and grass-finished bison carcass.

## **Materials and Methods**

### ***Animals and Carcass Data Collection***

Bison heifers were randomly assigned to finishing treatments: Grain-finished (n=108; backgrounded on pasture and finished for 130 d with ad libitum access to grass hay, alfalfa, and a corn and dry distiller's grain concentrate prior to slaughter) or Grass-finished (n=93; remained on pasture until slaughter). Heifers were transported (~720 km) to a commercial packing facility and slaughtered at a common endpoint of 28 mo of age over a 2-d period. Carcass measurements and camera images were collected at approximately 20 h postmortem. Carcasses were ribbed between the 12<sup>th</sup> and 13<sup>th</sup> rib and allowed to bloom. An expert USDA grader evaluated ribeye area, backfat thickness, and marbling score of one side of each carcass. In order to achieve optimal results from the camera images, the side that was free of abnormalities such as water pockets, blood or fat smudges, fat outlines, mis-ribbing, or an uneven ribeye surface was chosen to evaluate carcass measurements. USDA personnel then captured images of the exposed ribeye from the same side evaluated by the grader using a beef grading camera.

### ***Grading Camera, Calibration, and Imaging***

USDA personnel captured images of the exposed ribeye from the same side evaluated by the grader using the hand-held camera portion of a VBG2000 image processing system [GigE (Gigabit Ethernet) version: e+v Technology GmbH & CO KG, Oranienbury, Germany; Image 3-1]. Approximately 112 data points were automatically

determined from each image of the ribeye area including the carcass parameters necessary to determine preliminary yield grade, yield grade, ribeye area, marbling score, and unknown pixels. The VBG2000 consists of the hand-held camera, a PC, the system monitor, server and VGB2000 software programs.

The image processing system required an approximate 30 min daily startup time before use. The system was validated and calibrated each day before data collection was initiated. A system check was conducted to ensure correct function including inspection of the cleanliness of the camera window and test body and exact positioning of the nose and test body. Calibration of yield grade and marbling card readings within established levels for beef were conducted prior to carcass data collections (Images 3-2 to 3-12). Beef marbling cards included a series of images exhibiting low, medium, and high scores, and one card named “USDA” that is used for system maintenance purposes only (QAD 515A: Instrument Marbling Validation Cards –Target and Tolerance Values).

After the system check and calibrations were successful, carcasses were measured on the same side that was evaluated by the grader. To obtain images, the nose of the camera was placed on the exposed ribeye between the 12<sup>th</sup> and 13<sup>th</sup> rib in a manner that allowed the stop guide to lay against the vertebral bone surface, with the guide end in the spinal column channel (Image 3-13). The nose remained flat in order to capture a proper image. The system included a laser check for positioning: yellow flashing indicated the nose of the camera was 5 mm off of the carcass or tilted more than 5 mm, and red flashing indicated the nose was 8 mm off of the carcass (Images 3-14 to 3-16).

Once the camera was positioned, the trigger was pulled to release light, acquiring an image that could be evaluated. A monitor next to the measuring position displayed the

captured image for evaluation. Imaging was repeated if a positioning error occurred or the evaluated image quality was poor (Images 3-17 to 3-19). At the conclusion of imaging, the VGB200 data program evaluation was stopped. A detailed description of the camera technology and its general handling, imaging processing software, and technical specifications can be found in the VBG2000 system manual (2014).

Unidentified points encountered by the camera were assigned to the ‘unknown pixels’ category. The camera is strongly influenced by the ribeye area surface area. The unknown pixels category most likely resulted from pixels bouncing back during the imaging process, and the camera is unsure where to place them. It is possible that unknown pixels are linked to other carcass measurements. Therefore, the unknown pixel values were included in the statistical analysis to determine relationships to other camera carcass parameters.

### ***USDA Approval Process for Instrumental Grading***

The USDA-AMS-LS (2003 and 2005) has created a three-phase approval process that individual beef packing facilities must comply with before instrument grading can be used for evaluation of yield grade characteristics. In Phase I, USDA-AMS-LS standards approve instruments that exhibit the ability to assess given traits with accuracy and precision in an ideal or stationary setting (Belk and Woerner 2008). Phase II evaluates instruments exhibiting satisfactory levels of accuracy and precision at commercial production speeds, along with meeting requirements of Phase I. Lastly, Phase III certifies operational procedures, such as calibration and maintenance, for an individual packing facility utilizing an instrument while meeting requirements of Phase I and Phase II. Once an instrument has been approved in Phase III, the instrument is subsequently approved



for use as long as approved procedures are upheld (Belk and Woerner 2008). Currently, the VBG2000 has been approved through Phase II for assessment of REA, yield grade, and fat thickness.

USDA-AMS-LS (2006) has created Prime I and II standards for individual packing facilities to comply with for instrument approval of marbling evaluation. Prime I certification requires that accuracy, precision, and repeatability are met at commercial production speeds. Prime II standards provide requirements for the operational procedures for individual establishments intending to use an individual instrument already approved by Prime I (Belk and Woerner 2008). Facilities must meet requirements of Prime II before implementing an instrument for marbling evaluation. VBG2000 has met the requirements for Prime I to determine official USDA marbling score, however, it has not been approved by USDA for Prime II.

### *Statistical Analysis*

To assess the ability of the beef grading camera to evaluate bison carcass characteristics, both camera and grader measurements were analyzed using the MIXED procedures of SAS (SAS Inst. Inc., Cary NC), while yield grade data was analyzed using the GLIMMIX procedures for the main effect of finishing treatment; slaughter date was included as a random effect. Separation of least-squares main effect means was performed using LSD with a Tukey's adjustment, assuming  $\alpha = 0.05$ . Additionally, correlations between grader and camera measurements were analyzed using the CORR procedures of SAS.

## Results

Correlations were positive ( $P < .0001$ ) between expert grader and camera measurements for yield grade, backfat thickness, ribeye area, and marbling scores (Table 1). Correlations between the camera and grader were highest ( $R = .834$ ) for yield grade, and lowest ( $R = .451$ ) for marbling score measurements. Additional camera measurements identified as unknown pixels were found to be positively correlated ( $R = .621$ ,  $P < .0001$ ) with camera ribeye area, but not correlated ( $R = .002$ ,  $P = .9807$ ) with camera marbling measurements. The unknown camera pixels were not correlated ( $P = .2859$ ) with grader ribeye area, and negatively correlated ( $R = -.14$ ,  $P = .0494$ ) with grader marbling measurements.

USDA marbling score is the most variable factor influencing the value of graded beef carcasses, as other factors can be objectively measured using a tool, marbling score determination has no true measuring device to aid expert determination (Belk and Woerner 2008). Early studies investigating only the amount of marbling at the ribeye area muscle of the 12th rib separation using video image analysis (VIA) demonstrated very little association between expert assigned marbling scores and VIA predictions (Cross et al., 1983; Jones et al., 1992). These researchers noted during the assessment of marbling score, expert evaluators take into account the size and distribution of marbling depots in addition to the amount of marbling (Jones et al., 1992), as well as lean and fat color (Ferguson, 2004). Suggestions from these early studies indicate that marbling score prediction using VIA technology would need to utilize multiple variables in an equation, which actually defines how expert evaluators see marbling (Belk and Woerner 2008).

Possible differences in marbling scores between the camera and expert grader (Table 3-1 and 3-2) could be due to the limited marbling deposition of bison carcasses, which may be considered abnormally low for most beef carcasses. Koch et al. (1995) reported bison to have a marbling score of 319, which was significantly less than *Bos taurus* (386), or *bison x bos* hybrids (449) all fed similar concentrate diets. Bison studies, including the present study, indicate that lower marbling scores of bison (ranging from 200-400) would classify bison carcasses with “practically devoid” to “slight” amounts of marbling, therefore qualifying the carcasses as either select or standard quality grades if using the USDA beef quality grading system (American Meat Science Association (AMSA), 1990).

Grain-finished bison heifers had increased ( $P < .0001$ ) backfat thickness and marbling scores compared to grass-finished carcasses when evaluated by both the camera and expert grader. Grain-finished bison heifers had increased ( $P < .0001$ ) ribeye area compared to grass-finished when evaluated by grader, however ribeye area did not differ ( $P = .3189$ ) between finishing treatments when evaluated by the camera. When comparing mean values between the grader and camera measurements: camera ribeye area and marbling scores were increased, while camera backfat thickness was decreased in comparison to the expert grader values. Regardless of evaluation by camera or grader, yield grade was not impacted ( $P > .1000$ ) by finishing system, with the exception of an increase ( $P < .0001$ ) in the proportion of yield grade 1 carcasses in the grass-finished treatment when evaluated by the camera, and a tendency for an increased ( $P = .0965$ ) proportion of yield grade 2 in the grass-finished treatment when evaluated by the expert grader. Overall camera yield grades ranged from 1.0 to 5.90. Grass-finished carcasses

ranged between yield grades 1-4.76, however grain-finished ranged between yield grades 1.00-5.90 (Images 3-20 to 3-24). Camera marbling scores varied from a minimum 197.19 score to a maximum 513.37 score (Images 3-25 to 3-29). The smallest ribeye area camera measurement was 56.77cm<sup>2</sup> while the largest was 116.90 cm<sup>2</sup> (Images 3-30 and 3-31). Some of the smaller ribeye area measurements could be a result of camera positioning issues (Images 3-19 and 3-31), due to certain bison carcasses having an excess of back fat, ultimately causing a tilted ribeye area image that represents a smaller than normal ribeye area.

### **Implications**

Bison carcass data captured at the exposed ribeye using a beef grading camera were correlated with expert grader evaluations. However, the camera was most accurate for evaluating yield grade parameters and was least effective at evaluating marbling scores and ribeye areas. The accuracy of measurements and validation of a suitable camera grading system for bison will require additional investigation, including calibration and adjustments for bison carcass characteristics. Results of this work reveal the variation observed amongst bison carcasses. Therefore, if the bison industry seeks to establish a grading system it must address these differences. Additionally, it will be critical to understand consumer preferences for bison meat quality characteristics before establishing a carcass grading system. This ensures that the grading system includes the desired quality attributes for bison, and thus premiums could be appropriately applied to producers that meet consumer expectations.

### Literature Cited

- American Meat Science Association (AMSA). 1990. Recommended procedures for beef carcass evaluation and carcass contents. 3rd ed. AMSA, Chicago, IL.
- Belk, K. E., & Woerner, D. R. 2008. The history of instrument assessment of beef. Cattlemen's Beef Board and National Cattlemen's Beef Association.
- Cross, H. R., D. A. Gilliland, P. R. Durland, and S. Seideman. 1983. Beef carcass evaluation by use of a video image analysis system. *J. Anim. Sci.* 57:908
- Ferguson, D. M. 2004. Objective on-line assessment of marbling: A brief review. *Aust. J. Exper. Agr.* 44:681.
- Hale, D. S., K. Goodson, J. W. Savell. 2013. USDA Beef Quality and Yield Grades. Accessed 22 June, 2020. <https://meat.tamu.edu/beefgrading/>
- Jones, S. D. M., D. Lang, A. K. W. Tong, and W. M. Robertson. 1992. A commercial evaluation of video image analysis in the grading of beef carcasses. *Proc. 38th Int. Cong. Meat Sci. and Tech.* 38:915.
- Koch, R. M., H.G. Jung, J. D. Crouse, V. H. Varel, & L. V. Cundiff. 1995. Growth, digestive capability, carcass, and meat characteristics of *Bison bison*, *Bos taurus*, and *Bos x Bison*. *Journal of Animal Science.* 73, 1271-1281.
- Marchello, M. J., and J. A. Driskell. 2001. Nutrient Composition of Grass- and Grain-Finished Bison. *Great Plains Research* 11:65-82.
- National Bison Association (NBA). 2020. Current Status. Accessed 24 July, 2020 <https://bisoncentral.com/current-status/>
- QAD 515A. Instrument Marbling Validation Cards –Target and Tolerance Values.

<https://www.ams.usda.gov/sites/default/files/media/QAD%2015A%20Appendix%20Instrument%20Marbling%20Validation%20Cards.pdf>. Accessed 24 June 2020.

USDA-AMS-LS. 2017. United States Standards for Grades of Carcass Beef. Accessed 09 June, 2020.

<https://www.ams.usda.gov/sites/default/files/media/CarcassBeefStandard.pdf>

USDA-AMS-LS. 2006. Instrument Grading Systems for Beef Carcasses Performance Requirements for Instrument Marbling Evaluation (PRIME) I. Demonstration of Repeatability, Accuracy, and Precision. Accessed 30 June 2020.

<https://www.ams.usda.gov/sites/default/files/media/LSStandPrimeI.pdf>

<https://www.ams.usda.gov/sites/default/files/media/PrimeII.pdf>

USDA-AMS-LS. 2005. Procedures for approval and use of vision based Instrument systems for beef carcass and yield grade measurement. Accessed 09 July 2020.

<https://www.ams.usda.gov/sites/default/files/media/YieldGradeStandard2005.pdf>

USDA-AMS-LS. 2003. Procedures for approval and use of instrument Systems for beef carcass ribeye measurements. Accessed 09 July 2020.

<https://www.ams.usda.gov/sites/default/files/media/ProcedureForRibeyeApproval2003.pdf>

VBG2000 System Manual. 2014. GigE (Gigabit Ethernet) version: e+v Technology GmbH & CO KG, Oranienbury, Germany.

[file:///C:/Users/Jessica/Downloads/e+v%20System%20Manual.LED.20140604%20\(1\).pdf](file:///C:/Users/Jessica/Downloads/e+v%20System%20Manual.LED.20140604%20(1).pdf)

f

**Table 3-1.** Correlations of bison carcass characteristics between VBG2000 image processing system and USDA expert grader evaluations.

Variables <sup>1</sup>	R-value	P-value
Camera YG & Calculated YG	.978	<.0001
Camera YG & Calculated Grader YG	.834	<.0001
Calculated Camera YG & Calculated Grader YG	.828	<.0001
Camera Back Fat & Grader Back Fat	.678	<.0001
Unknown Pixels & Camera REA	.621	<.0001
Camera REA & Grader REA	.473	<.0001
Camera Marbling & Grader Marbling	.451	<.0001
Unknown Pixels & Grader REA	.076	0.2859
Unknown Pixels & Camera Marbling	.002	0.9807
Unknown Pixels & Grader Marbling	-.140	0.0494

<sup>1</sup>Calculated Yield Grade: calculated using regression equation and given carcass parameters:  $YG = 2.5 + (2.5 * \text{Adj BF}) + (.20 * \text{KPH, \%}) - (.32 * \text{REA}) + (.0038 * \text{HCW})$

Unknown Pixels: Unidentified points encountered by the camera. The camera is strongly influenced by the ribeye area surface area. The unknown pixels category most likely resulted from pixels bouncing back during the imaging process

**Table 3-2.** A comparison of least squares means for effect finishing systems on bison carcass characteristics VBG2000 image processing system and USDA expert grader evaluations.

Variable	USDA Grader				USDA Camera			
	GRAIN <sup>1</sup>	GRASS <sup>1</sup>	SEM <sup>2</sup>	<i>P</i> -value <sup>3</sup>	GRAIN <sup>1</sup>	GRASS <sup>1</sup>	SEM <sup>2</sup>	<i>P</i> -value <sup>3</sup>
Ribeye area, cm <sup>2</sup>	64.58	57.48	0.768	<.0001	72.32	70.71	1.626	.3189
Back fat thickness, in	2.16	0.89	0.084	<.0001	1.65	0.76	0.099	<.0001
Marbling Score <sup>4</sup>	389.36	243.67	9.924	<.0001	364.30	323.27	7.326	<.0001
USDA Yield Grade, % <sup>5</sup>								
Yield Grade 1	-----	-----	-----	-----	1.87	39.56	7.070	<.0001
Yield Grade 2	5.56	55.91	5.148	.0965	12.26	34.07	4.968	.1754
Yield Grade 3	29.63	19.35	4.394	.3435	28.30	21.98	4.375	.4954
Yield Grade 4	46.30	3.23	4.798	.1195	34.91	4.40	4.630	.1403

<sup>1</sup>Treatments; GRAIN = bison heifers (n=108) backgrounded on grain and finished for 130 days with ad libitum access to grass hay, alfalfa, and a corn and dry distiller's grain concentrate prior to slaughter. GRASS = bison heifers (n=93) remained on pasture until slaughter

<sup>2</sup>Standard error of the mean

<sup>3</sup>Probability of difference among least square means:

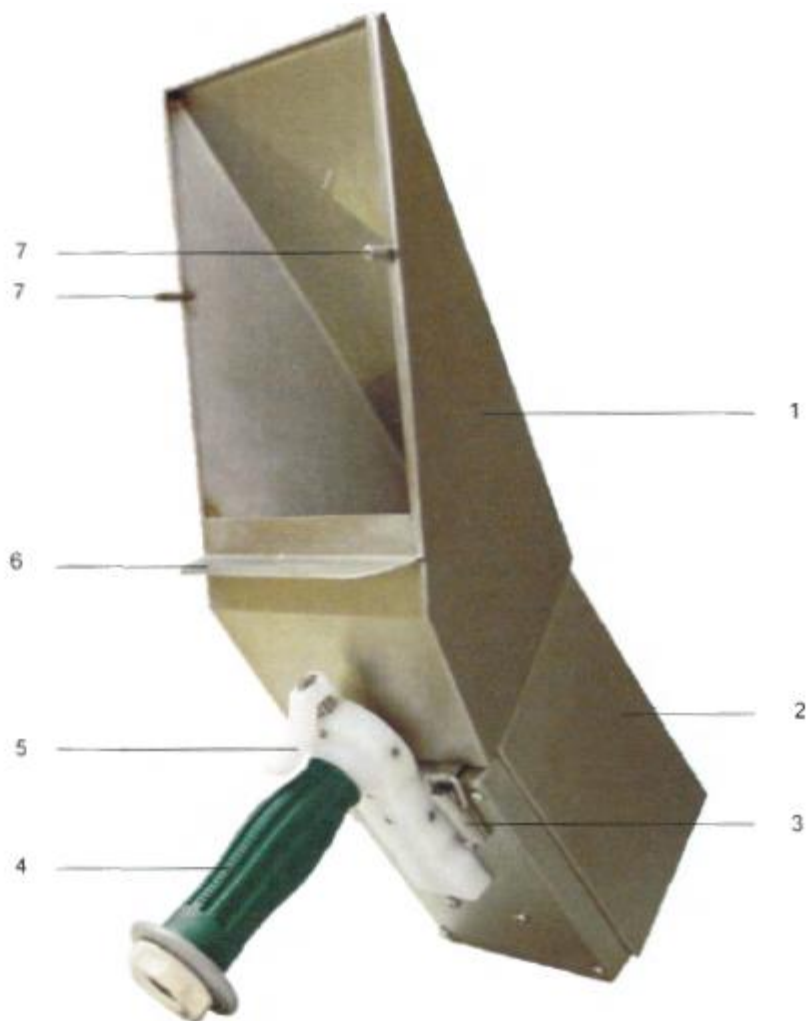
<sup>4</sup>Marbling score: 100=Practically Devoid<sup>0</sup>, 200=Traces<sup>0</sup>, 300=Slight<sup>0</sup>, 400=Small<sup>0</sup>, 500=Modest<sup>0</sup>

<sup>5</sup>Yield Grade assigned by USDA; Grader data set contained YG 1 (n=20) and 5 (n=20), and camera data set contained YG 5 (n=24). However the models did not converge



### Camera System Overview and Calibration Images:

**Image 3-1:** Hand Camera System (Pistol)



1. Positional facility (Nose)
2. Camera housing
3. Quick-locking mechanism
4. Replaceable handle
5. Trigger
6. Stop/Guide
7. Positioning pins

**Image 3-2:** Calibration: C395\_2018-10-01\_19-51-07



**Image 3-3:** Calib\_C395\_2018-10-02\_02-55-28



**Image 3-4:** Calib\_C395\_2018-10-02\_02-55-12



**Image 3-5:** Calib\_C395\_2018-10-02\_02-53-30



**Image 3-6:** Calib\_C395\_2018-10-02\_02-52-53



**Image 3-7** Calib\_C395\_2018-10-02\_02-52-25



**Image 3-8.** Calib\_C395\_2018-10-02\_01\_19-52-06



**Image 3-9.** Marb\_1\_C395\_2018-10-01\_19-52-37-0



**Image 3-10.** Marb\_2\_C395\_2018-10-01\_19-52-55-1



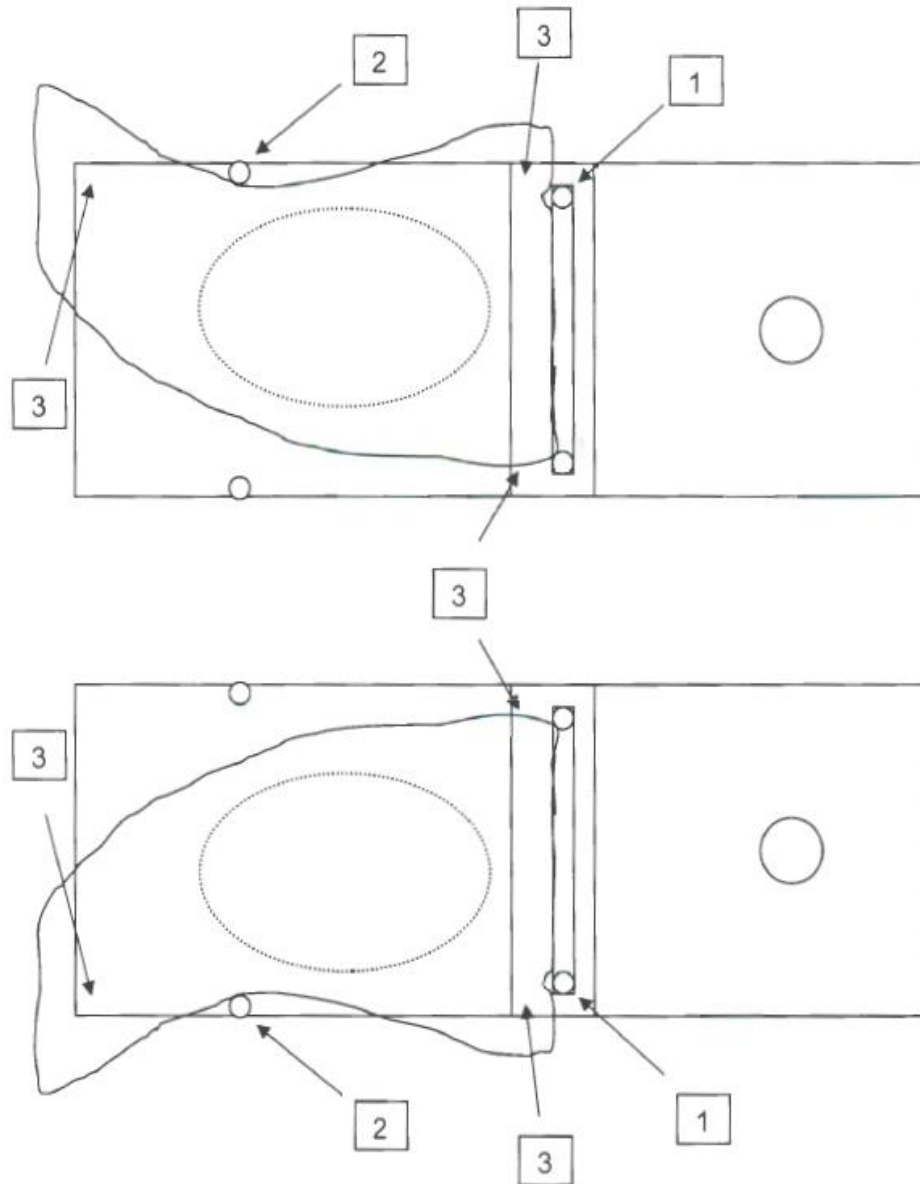
**Image 3-11.** Marb\_3\_C395\_2018-10-01\_19-53-13-2



**Image 3-12.** Marb\_4\_C395\_2018-10-01\_19-53\_32-1



**Image 3-13:** Correct Placement of VBG2000 on Ribeye Surface



- 1 place guide end inside spinal channel
- 2 place pin against ribs
- 3 place camera nose totally on the meat

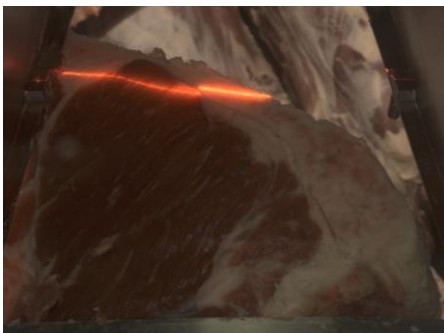
**Image 3-14:** Shade Cam 395



**Image 3-15:** Laser Cam 395



**Image 3-16:** Laser Image, Camera ID: 106-2

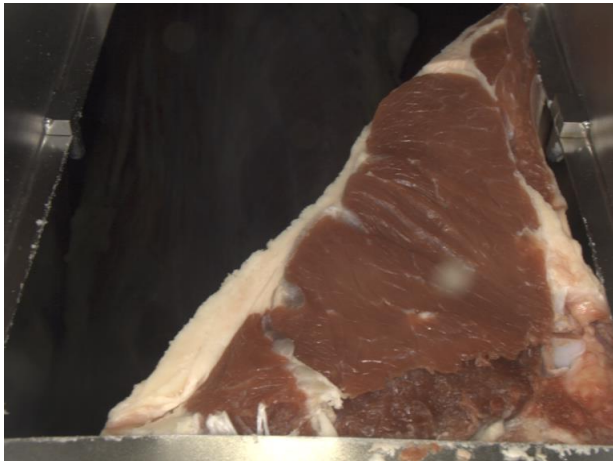


### Examples of Poor Bison Ribeye Area Images

**Image 3-17.** Blurry image with spots. Camera ID: 65



**Image 3-18.** Spotty image. Camera ID: 65



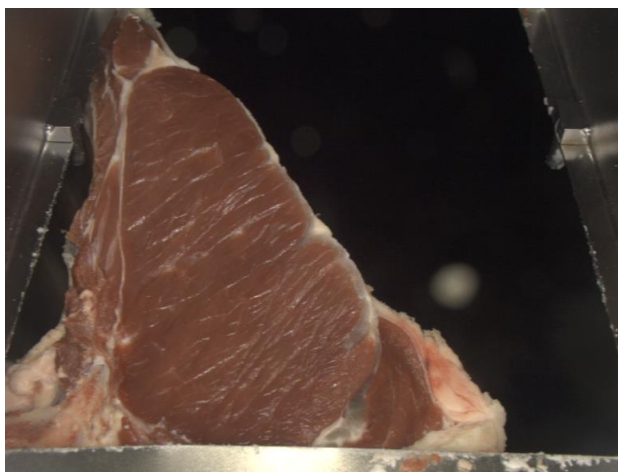
**Image 3-19.** Tilted Ribeye Image. Camera ID: 196



**Table 3-3. Yield Grade Ranges.** Carcass camera parameters and corresponding grader evaluations for selected ribeye images.

Image ID	Finishing Treatment	REA cm <sup>2</sup>	Side	Camera YG	Grader YG	PYG	ADJ PYG	Marbling
3-20	Grass	75.23	R	<b>1.00</b>	<b>1.82</b>	2.30	1.86	405.88
3-21	Grass	73.23	L	<b>2.15</b>	<b>2.45</b>	2.96	2.90	282.01
3-22	Grain	67.99	L	<b>3.34</b>	<b>3.15</b>	3.80	3.44	377.77
3-23	Grain	68.45	R	<b>4.16</b>	<b>3.59</b>	4.17	4.03	315.66
3-24	Grain	65.16	L	<b>5.90</b>	<b>4.95</b>	6.45	5.92	499.09

**Image 3-20.** YG 1.00. Camera ID: 61-1



**Image 3-21.** YG 2.15. Camera ID: 125-2





**Image 3-22.** YG 3.34. Camera ID: 90



**Image 3-23.** YG 4.16. Camera ID: 170-1



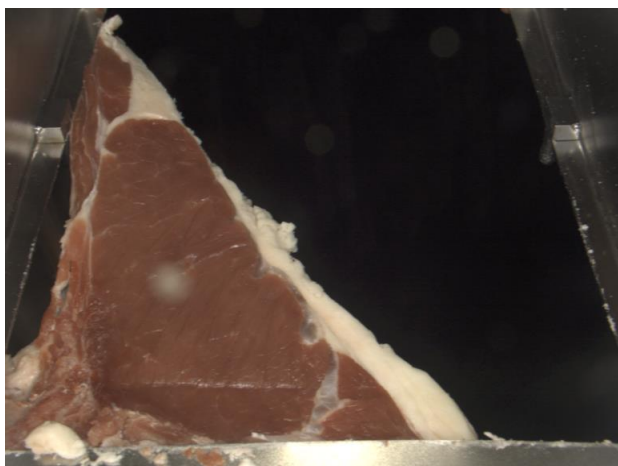
**Image 3-24.** YG 5.90. Camera ID: 260-2



**Table 3-4. Marbling Scores Ranges.** Carcass camera parameters and corresponding grader evaluations for selected ribeye images

Image ID	Finishing Treatment	REA cm <sup>2</sup>	Side	YG	PYG	ADJ PYG	Camera Marbling	Grader Marbling
3-25	Grass	62.39	L	2.04	2.67	2.42	<b>197.19</b>	<b>270</b>
3-26	Grass	61.94	R	2.09	2.60	2.32	<b>250.21</b>	<b>150</b>
3-27	Grass	63.99	L	3.52	4.34	3.76	<b>329.43</b>	<b>350</b>
3-28	Grain	68.45	L	4.16	4.17	4.03	<b>441.00</b>	<b>420</b>
3-29	Grain	69.35	L	4.56	4.70	4.54	<b>513.37</b>	<b>520</b>

**Image 3-25.** Marbling: 197.19. Camera ID: 137-2



**Image 3-26.** Marbling: 250.21. Camera ID: 72-1



**Image 3-27.** Marbling: 329.43. Camera ID: 148-2.



**Image 3-28.** Marbling: 441.00. Camera ID: 106-2



**Image 3-29.** Marbling: 513.37. Camera ID: 20-2



**Table 3-5. Ribeye areas.** Carcass camera parameters with corresponding grader evaluation and ribeye images

Image ID	Finishing Treatment	Camera REA cm <sup>2</sup>	Grader REA cm <sup>2</sup>	Side	YG	PYG	ADJ PYG	Marbling
3-30	Grass	<b>116.90</b>	<b>65.81</b>	L	1.42	4.43	3.96	378.36
3-31	Grain	<b>45.35</b>	<b>56.77</b>	L	5.90	8.09	6.93	336.63

**Image 3-30.** Image 164-2: Largest Camera REA: 116.90 cm<sup>2</sup>



**Image 3-31.** Cam ID: 196-2, Smallest Camera REA 56.77 cm<sup>2</sup>



CHAPTER 4: CARCASS CHARACTERISTICS, ANIMAL STRESS RESPONSE,  
MEAT QUALITY, AND CONSUMER PREFERENCE OF BISON HEIFERS  
HARVESTED IN MOBILE OR COMMERCIAL ABATTOIRS

**Abstract**

The objective of this study was to evaluate the influence of harvest system (on-ranch or commercial harvest system) on stress response, carcass characteristics, meat quality, and consumer preference of bison. Grass-finished bison heifers were randomly assigned to harvest treatments: Commercial (n=93, transported ~720 km to a commercial harvest facility) or On-ranch (n = 40, harvested on-ranch using a mobile slaughter unit). Blood samples were collected immediately following exsanguination and analyzed for serum cortisol and haptoglobin concentrations. Approximately 20 h postmortem, ribeye area, back fat thickness, marbling score, and instrumental color of the exposed ribeye and subcutaneous fat opposite the ribeye were recorded. A subsample (n=30 carcasses closest to the average hot carcass weight for each treatment) was selected and striploins were removed from one side of each carcass. Ultimate pH was recorded, and striploins were fabricated into 2.54-cm steaks. One steak was designated for crude fat determination. Two steaks were aged for 14 d and frozen for Warner-Bratzler shear force (WBSF) analysis, cook loss determination, and consumer sensory evaluation. Cortisol and haptoglobin concentrations, body weight, carcass characteristics, and meat quality data were analyzed using the MIXED procedure of SAS for the main effect of harvest treatment; slaughter date was included as a random effect, and peak temperature was included as covariate for WBSF and cook loss. Consumer preference data was analyzed using the MIXED procedures for the main effects of harvest treatment and serving order;

serving time and panelist were included as random effects. Separation of least-squares means was performed using LSD with a Tukey's adjustment, assuming  $\alpha = 0.05$ . Commercially harvested bison heifers had elevated ( $P < .0001$ ) cortisol concentrations compared to heifers harvested on-ranch. Carcass weight, dressing percent, and ribeye area were greater ( $P < .0001$ ) for heifers harvested commercially compared with the on-ranch harvest system. Instrumental color values ( $L^*$ ,  $a^*$ ,  $b^*$ ) recorded at the ribeye area and  $L^*$  value of back fat opposite the ribeye were increased ( $P < .01$ ) for heifers in the commercially harvested treatment. However,  $a^*$  and  $b^*$  values recorded for back fat opposite the ribeye were decreased ( $P < .05$ ) in commercially harvested heifers. Heifers harvested on-ranch produced striploins with increased ( $P = .0007$ ) ultimate pH. Steaks from heifers harvested commercially had increased ( $P = .0045$ ) ether extractable fat percentage. Steaks from the on-ranch harvest system had less ( $P < .0001$ ) cook loss than steaks from the commercial system. Harvest treatment did not influence ( $P > .10$ ) haptoglobin concentration, live body weight, or back fat. Marbling scores and tenderness tended ( $P < .10$ ) to be increased for bison heifers harvested on-ranch. Results from the consumer sensory panel revealed that steaks from the commercial harvest system tended to rate higher ( $P < .10$ ) for aroma liking than steaks from the on-ranch system. No other sensory differences were detected ( $P > .10$ ). Collectively these data indicate that harvest systems influence short-term stress response, and some carcass and meat quality characteristics of bison heifers. However, harvest systems had minimal impact on consumer preference for bison.

## Introduction

Bison (*bison bison*) are large animals that can show increased signs of aggression and become easily excited compared to domesticated ruminants (Rioja-Lang et al., 2018). Such behavior requires improved working and housing facilities as well as stronger and taller fencing in pastures to ensure proper management and safety (NBA: Current Status, 2020). The use of on-sight or mobile units are common for slaughtering bison in order to minimize transportation, handling, and animal stress. Temperament has been correlated with other physiological measures of stress, such as cortisol, in cattle (Fell et al., 2000; King et al., 2006), but there has been limited genetic selection for traits such as temperament in farmed bison, which may result in a large variation within a population's ability to cope with stress (Galbraith 2011).

Mobile harvest units can provide niche market opportunities for producers as they facilitate placement of low volume, but high value livestock products for local market sales (Galbraith 2011). However, the majority of bison in the U.S. are harvested using commercial facilities, which generally provide a more controlled harvest environment and can accommodate higher throughput allowing for production of larger volumes. There are a limited number of commercial packing facilities approved to receive and slaughter bison within the United States (USDA-APHIS, 2020), therefore extended transportation distances to commercial harvest facilities is common. Production and consumption of bison has increased significantly since they were hunted to near extinction in North America during the late 1800's (Marchello and Driskell, 2001). Currently it is estimated that there are approximately 400,000 bison in North America (including private, state, federal, and tribal herds; National Bison Association: Current Status, 2020). Despite increasing

popularity, quality attributes such as tenderness, juiciness, and flavor, as well as consumer preferences for bison are not well understood, which limits opportunities to expand markets. Further, use of different harvest systems could lend to product variation. Currently, there is limited research on the carcass characteristics produced across the U.S. bison industry. Therefore, the objective of this study was to characterize the influence of harvest systems (on-ranch vs. commercial) on stress response, carcass characteristics, meat quality, and consumer preference of bison.

## **Materials and Methods**

### ***Treatments and Blood Sample Collection***

To compare the influence of harvest system (on-ranch vs. commercial harvest facility) on meat quality and sensory characteristics of bison heifers, grass-fed heifers described in chapter 2 served as the commercial harvest treatment group for this study. An additional group of grass-finished bison heifers ( $n = 40$ ) of the same age, source, and background as the animals described in chapter 2, and were harvested at a ranch in central South Dakota and served as the on-ranch harvest treatment. Heifers in the on-ranch treatment were harvested at approximately 28 mo of age using a mobile harvest unit over a three-day harvest period. Heifers were placed in an approximately 40-acre harvest pasture where they were rendered unconscious by a sharp-shooter and exsanguinated by severing the jugular vein and carotid artery. Blood samples were collected immediately following exsanguination using blood collection tubes (Vacutainer plus SST; Serum Separator Tubes). Samples were centrifuged for 18 min and the serum layer was collected, divided in to two aliquots, and frozen. Frozen serum samples were transported back to the South



Dakota State University Meat Science Laboratory and stored for approximately 2 months until preparation for serum cortisol and haptoglobin analysis. Following exsanguination, heifers were shackled and transported via a modified hydraulic pickup bed (approximately 0.8 km) to the processing trailer to complete the dressing process. Carcasses were held in the cooler section of the mobile unit until all carcasses were processed.

### ***Carcass Evaluation, and Striploin Collection***

At the completion of the on-ranch harvest, carcasses were transported 175 km to a fabrication facility in Rapid City, SD. Carcasses were ribbed between the 12<sup>th</sup> and 13<sup>th</sup> rib for evaluation of ribeye area (REA), back fat thickness, and marbling score by South Dakota State University personnel. Objective color of the exposed ribeye and subcutaneous fat opposite the ribeye were recorded as described in chapter 2. A subsample (n = 30 carcasses closest to the average hot carcass weight (HCW) of each treatment group) was selected and the striploins were removed from one side, vacuum packaged, and transported back the South Dakota State University Meat Laboratory.

### ***Serum Analysis***

To evaluate the influence of harvest system on the stress response of grass-finished bison heifers serum samples from commercially harvested (n=93) on-ranch harvested (n=40) were analyzed for cortisol and haptoglobin concentrations. A random number generator was used to create a subsample (n = 80) of serum samples from commercially harvested heifers.

A cow haptoglobin enzyme-linked immunosorbent assay (ELISA, Life Diagnostics, INC., West Chester, PA, Catalog Number: Hapt-11) was utilized according

to manufacturer's instructions to evaluate bison haptoglobin concentration. Normal serum levels of cow haptoglobin range from ~25-50  $\mu\text{g/ml}$ . A plate reader (ELx808; BioTek Instruments, Inc, Winooski, VT) was used to measure absorbance at 450 nm. The concentration of haptoglobin was proportional to the absorbance derived from a standard curve.

Serum concentrations of cortisol were determined in duplicate by radio immune assay using the ImmunChem Coated Tube Cortisol kit (MP Biomedicals, Solon, OH, Catalog Number: 07221102) according to the manufacturer's directions. Sensitivity of the assay was 0.02  $\mu\text{g/dL}$  and inter and intra-assay CV were 12.2% and 10.1%, respectively. Inhibition curves of serum ranging from 10 to 25  $\mu\text{L}$  were parallel to the standard curve. Recovery of 3, 10, and 30  $\mu\text{g}$  of cortisol added to serum was 86.5%.

### ***Meat Quality Analysis***

Upon arrival at the South Dakota State University meat laboratory striploins were removed from vacuum packaging, trimmed of external fat, and an ultimate pH measurement was recorded using as described in chapter 2. Each striploin was then fabricated into 2.54-cm steaks and individually vacuum packaged. To account for steak location, steaks were systematically assigned for meat quality analyses. The first anterior steak was designated for crude fat and moisture determination and was frozen immediately after fabrication. One steak was designated for Warner-Bratzler shear force (WBSF) and was stored for 14 d at 4°C, then frozen. Two steaks were assigned to consumer sensory panels, aged for 14 d, and frozen. Warner-Bratzler Shear Force (WBSF) analysis, and determination of crude fat and moisture content were conducted as outlined in chapter 2.

### ***Consumer Sensory Panel***

A consumer sensory panel was conducted at the University of Minnesota, Department of Food Science and Nutrition, Sensory Center to compare the meat quality characteristics of bison striploin steaks from on-ranch and commercial systems. Panelists (n=113) were recruited from the student and staff population of the University of Minnesota and included anyone who expressed an interest in participating in sensory tests. The University of Minnesota's Institutional Review Board (IRB) approved all recruiting and experimental procedures (IRB #6792). Methods for sample preparation and administration of the consumer sensory panel are described in chapter 2. The sensory ballot, and participant demographics are listed in APPENDIX A and C.

### ***Statistical Analysis***

Animal live weight, dressing percent, carcass measurements, serum analyses, ultimate pH, WBSF, cook loss, crude fat, and moisture content were analyzed using the MIXED procedures of SAS (SAS Inst. Inc., Cary, NC) all for the main effect of harvest treatment; kill date was included as a random effect, and peak temperature was used as covariate for shear force and cook loss. Consumer preference data was analyzed using the MIXED procedures of SAS for the main effects of harvest treatment and serving order; time and panelist were used as random effects. For all attributes except off-flavor and juiciness ratings, serving order was not significant and omitted from the final model. Separation of least-squares means was performed using LSD with a Tukey's adjustment and assuming a level of 0.05.

## Results and Discussion

### *Animal Stress Response*

Animal stress response results are presented in Table 4-1. Commercially harvested bison heifers had elevated ( $P < .0001$ ) cortisol concentrations compared to heifers harvested on-ranch. However, harvest treatment did not influence ( $P = .9940$ ) haptoglobin concentrations. Cortisol is a corticosteroid hormone released from the adrenal cortex during episodes of stress to help restore homeostasis (Munck et al., 1984). Thus, serum cortisol levels are an indication of the immediate physiological condition resulting from stress (Galbraith, 2011). The elevated cortisol levels of the bison heifers harvested commercially are likely the response to transportation (700 km), additional handling necessary for transport, introduction to a novel environment, overnight lairage, and separation from herd mates. Research has also shown that red deer (*Cervus elaphus*) that were immobilized in a field or paddock had plasma cortisol levels consistent with an unstressed state, compared to the elevated concentrations of deer harvested commercially (Pollard et al., 2002; Smith and Dobson, 1990). Galbraith (2011) compared the stress response of bison harvested at a stationary abattoir to bison harvested using a mobile harvest unit. Bison harvested using a mobile harvest unit were either penned or confined in a squeeze chute prior to immobilization. Similar to the present study, cortisol levels were lowest in bison penned and harvested with a mobile slaughter unit.

Acute phase proteins, such as haptoglobin, are groups of proteins that change in concentration when animals are subjected to external and internal stressors, such as infection, trauma, inflammation or chronic stress, and act as inhibitors or mediators of inflammatory processes (Del Campo et al., 2008). As heifers in this study did not

experience chronic stress prior to harvest and were not exhibiting any signs of disease or morbidity, the lack of difference in serum haptoglobin between harvest systems is not surprising. Similarly, when evaluating the physiological stress in bison slaughtered in a mobile or stationary abattoir, Galbraith (2011) noted that the bison transported to the stationary abattoir appeared to be able to cope with the stress associated with handling and transport.

### *Carcass Characteristics*

Carcass characteristic results are presented in Table 4-2. Animal live weight, carcass weight, dressing percent, and ribeye area were greater ( $P < .0001$ ) for heifers harvested commercially compared with the on-ranch harvest system. Marbling scores tended ( $P = .0974$ ) to be increased for bison heifers harvested on-ranch. Harvest treatment did not influence ( $P = .9927$ ) live body weight, or back fat ( $P = .1105$ ). Given that live weight was similar between treatments differences in dressing percentage and HCW are likely partially due to the application of a vascular rinsing solution applied to carcasses at the commercial facilities but not the on-ranch treatment. Further, on-ranch heifers were allowed graze on pasture up to the time of slaughter, while heifers harvested commercially were subjected to feed withdrawal for approximately 12 hours resulting in less fill and a lighter viscera relative to carcass weight. The harvest systems also utilized different processes for transforming the animal into a dressed carcass, such as hide removal and trimming processes, which could also contribute to differences in carcass weight and dressing percentage between harvest systems. Differences observed in REA could be the result of different personnel ribbing the carcasses or could be a random biological difference that is unrelated to treatments.

Bison heifers harvested on-ranch remained on pasture and were able to graze up to the time of slaughter, which could be related to their improved marbling scores. Studies by Schaefer et al. (2001 and 2006) examined the effects of providing antemortem nutrition to beef cattle 12 to 24 hours prior to slaughter and observed a 20% or better retention of the visible appearance of marbling compared to those withdrawn from nutrition. However, both scores (295.19 and 243.57 for on-ranch and commercial, respectively) would be classified as traces according to USDA beef marbling score standards and would qualify for the Standard quality grade.

### ***Objective Color***

Objective color results are presented in Table 4-2. Instrumental color values ( $L^*$ ,  $a^*$ ,  $b^*$ ) recorded at the exposed ribeye surface and  $L^*$  value of the subcutaneous fat opposite the ribeye were increased ( $P < .01$ ) for heifers harvested in the commercial system compared to those harvested on-ranch. The  $a^*$  and  $b^*$  values recorded at the subcutaneous fat opposite the ribeye were increased ( $P < .05$ ) in heifers harvested on-ranch. Galbraith (2011) also reported the greatest proportions of bison carcasses identified with “slightly dark to black” lean muscle color were harvested using a mobile slaughter unit compared to a stationary abattoir. Color differences in the present study could also be influenced by the application of a vascular rinse early postmortem. Infusion of a chilled vascular rinsing solutions aids in the removal of residual blood from carcasses, which generally results in lighter colored meat (Farouk and Price 1994; Dikeman et al., 2003). Mickelson and Claus (2020) reported *Longissimus lumborum* steaks from bison carcasses subjected to vascular infusion had increased  $L^*$  and  $a^*$  values, compared to conventionally chilled bison steaks,

however no differences in  $b^*$  values were observed. Lambs subjected to vascular infusion were reported to have increased  $L^*$  and  $b^*$  when measured at the *Longissimus lumborum* surface compared to the control group receiving no infusion (Fowler et al., 2017). Hunt et al., (2003) also reported vascular rinsed and chilled *Longissimus lumborum* beef steaks had increased  $L^*$  values, and had a lighter and redder initial appearance than steaks from non-infused carcasses when evaluated by trained visual panelists.

Increased yellowness of external fat is likely related to increased  $\beta$ -carotene deposition within adipose tissue and is commonly observed in forage fed animals (Duckett et al., 2009, 2013). All bison heifers in the current study, regardless of harvest treatment, were grass-finished and maintained in the same pasture until slaughter. However, bison heifers harvested on-ranch exhibited a yellower and redder external fat than carcasses harvested commercially. This could be due to differences in the hide removal process between the two systems. Heifers harvested on-ranch had their hides removed by hand using skinning knives resulting in more blood left on the external cover of the carcass, while the commercial facility utilized a hide puller. Also, heifers slaughtered commercially were subjected to carcass rinsing stations, which minimizes residual blood or debris on the external surface of the carcass.

### ***Meat Quality Characteristics***

Meat quality results are presented in Table 4-3. Heifers harvested commercially produced striploins with decreased ( $P = .0007$ ) ultimate pH, as well as increased cook loss ( $P < .0001$ ), moisture percentage ( $P = .0003$ ), and ether extractable fat percentage ( $P = .0045$ ) compared to steaks from the on-ranch system. On-ranch samples tended to have decreased WBSF values ( $P = .0716$ ). Ether extractable fat percentages analysis was added

to this study to help further investigate the tendency for marbling scores to differ between harvest systems. However, the fat percentages disagree with the subjective marbling score results. It is possible that the tendency for differences in marbling scores is due different personnel conducting evaluations at each location. However, both marbling scores would be classified as traces amounts, therefore qualifying for a standard beef quality grade. While there were significant statistical differences detected between harvest systems for fat percentage, numerically the results were very similar (1.94. and 1.44%, for commercial and on-ranch respectfully). It appears bison heifers used in this study had minimal amounts of intramuscular fat, which could also contribute to the conflicting results between subjective and chemical evaluations.

Although pH decline patterns of bison carcasses subjected to vascular infusion have yet to be determined, findings from previous research suggest vascular infusion may result in a more rapid pH decline than control carcasses (Mickelson and Claus, 2020; Dikeman et al., 2003; Farouk and Price, 1994). A faster pH decline could affect protein functionality if the infused solution was not able to lower the meat temperature rapidly enough to counter the impact of a lower pH, as low pH and increased temperatures can cause decreased water holding capacity (Mickelson & Claus 2020). Decreased water holding capacity could contribute to the increased cook loss observed in the commercially harvested bison. Also, as commercially harvested bison were infused with a solution at a rate of 8% of their body weight, this excess moisture could contribute to increases in percent moisture and cook loss. Mickelson and Claus (2020) reported that vascular infused bison produced *Longissimus lumborum* steaks with increased cook loss compared to steaks from carcasses not subjected to infusion. Warner et al. (2007) reported that acute stress induced by the



application of electric prods to cattle 15 min pre-slaughter detrimentally affected the water-holding capacity of the loin muscle and consumer acceptability of 21-day aged beef. However, Warner et al. (2007) reported no differences in ultimate pH, glycolytic rate, or temperature decline between prodded and control cattle. Acute pre-slaughter exercise has been reported to cause a reduction in the water-holding capacity of the loin and leg muscles of lambs (Warner et al., 2000). Thus, acute stress experienced by commercially harvested bison heifers could also contribute to differences in cook loss.

Stress during the antemortem period may result in altered biochemical processes in postmortem skeletal muscle, which can influence meat tenderness (Sentandreu et al., 2002). A chronic or long-term stress depletes muscle glycogen, which then inhibits postmortem metabolism processes, and reducing lactic acid production, which ultimately creates an abnormal muscle to meat conversion known as a “dark cutter” or “dark, firm, dry” (DFD). Meat classified as DFD possesses a dark, lean, firm texture, dry surface, and increased muscle pH (Aberle et al., 2001). Wulf et al., (2002) reported that cooked longissimus from DFD beef carcasses had increased shear force values (46% greater) and more shear force variation (2.3 times greater variation) than those from normal carcasses. When animals undergo an acute stress prior to slaughter, the impacts on meat are defined as a pale, soft, exudative (PSE) condition, which is caused by a rapid rate of glycolysis and a relatively low muscle pH immediately after slaughter when carcass temperatures are high (Wisner-Pederson, 1959). Pork experiencing PSE conditions generally has reduced tenderness partially due to reduced enzymatic degradation activities in postmortem muscle (Claeys et al., 2001). The impacts of stress on tenderness appears to vary and depend on the level of stress experienced. Bison heifers harvested commercially

could have experienced an acute stress prior to slaughter, as they had elevated cortisol levels but a decreased ultimate striploin pH compared with heifers harvested on-ranch. However, the cortisol level of that would signify a stress response in bison is unknown. Further, the influence of acute stress on bison tenderness has not been reported and it is unknown if they would react similarly to other species.

In studies investigating tenderness of *Longissimus lumborum* from beef and lamb infused with a saccharide, NaCl, and phosphate solution; Yancy et al. (2002) reported no difference in beef tenderness between chilling systems, however Dikeman et al. (2003) reported decreased beef tenderness. Fowler et al. (2017) reported improved lamb tenderness for infused steaks compared to control steaks. Additionally, Mickelson and Claus (2020) reported infused bison produced steaks with decreased shear force values compared to those not infused. Overall, there are conflicting reports in the literature regarding the influences of vascular infusion on meat tenderness. Therefore, it is difficult to establish if the application to bison carcasses harvested commercially in this study is responsible for the tendency for shear force values to differ between harvest treatments.

There is evidence indicating the rate at which carcasses cool after slaughter can influence meat tenderness by impacting the rate enzymatic protein degradation and cold-shortening of sarcomeres (Locker et al. 1985; Smulders et al., 1992; Herring et al., 1965). Galbraith (2011) revealed that bison carcasses chilled in mobile slaughter units had increased muscle temperatures at 5 and 10 h postmortem compared to bison carcasses chilled at a stationary abattoir. Heat loads for the mobile slaughter unit cooler were much greater than the larger coolers at the stationary facilities, resulting in less efficient or slowed carcass chilling (Galbraith, 2011). Slowed postmortem chilling improves tenderness by

preventing cold-induced muscle shortening in the *Longissimus dorsi* and some other muscles (French et al., 2001). It is possible that the on-ranch mobile unit's trailer was less efficient at chilling bison carcasses compared to the larger coolers of the commercial facilities, which may have caused a slower carcass temperature decline. However the harvest facilities cooler temperatures and bison carcass temperature declines were not recorded in the current study.

### ***Consumer Preference***

Consumer preference results are presented in Table 4-4. Results from the consumer sensory panel revealed that steaks from the commercial harvest system tended to rate higher ( $P = .0503$ ) for aroma liking than steaks from the on-ranch system. No other sensory differences were detected ( $P > .10$ ) between harvest systems. Galbraith (2011) reported that bison transported for harvest to a stationary abattoir rated significantly lower for initial tenderness and tended to rate lower for overall tenderness and overall palatability compared to steaks from bison harvested by a mobile harvest unit when evaluated by sensory panelists. However, no other differences between treatment groups for initial juiciness, flavor desirability, bison flavor intensity, connective tissue, overall tenderness, and sustainable juiciness for bison steaks were reported (Galbraith, 2011). The study by Galbraith (2011) utilized both male and female bison from four different source ranches, ranging from 16 to 40 months of age, and were all provided a variety of finishing diets. Therefore, it is possible that other factors could have impacted results in addition to the different harvest treatments. Regardless of harvest system treatment, bison used in the present study were all heifers, approximately 28 months of age, grass-finished, and

obtained from the same source ranch. Differences in animal background, age, sex, and diet between the current study and Galbraith (2011) could all contribute to the reported differences in sensory evaluation results between studies.

### **Conclusion**

Collectively these data indicate that bison harvest systems influenced some measures of animal stress response; as bison heifers harvested commercially had increased cortisol levels compared to those harvested on-ranch. However, harvest system had no impact on chronic stress response of bison heifers. Harvest systems influenced some carcass traits, as heifers harvested commercially had increased carcass weights, dressing percentages, and ribeye areas. Harvest systems influenced cook loss, moisture content, and ultimate striploin pH; as bison steaks from the commercial harvest had increased cook loss and moisture percentages but decreased ultimate striploin pH compared to those harvested on-ranch. Regardless of the observed carcass and meat quality differences, harvest systems had minimal impact on tenderness and consumer preference for bison. Continued research utilizing a trained sensory panel would allow further investigation of the influence of harvesting system, if any, on the descriptive analysis of the quality attributes of bison steaks. Additionally, further research investigating cooler temperatures and carcass temperature and pH decline between the two facilities would help further investigate possible differences in associated with animal stress impacts on meat quality.

### Literature Cited

- Aberle, E. D., J.C. Forrest, D. E. Gerrad, E. E. Mills. 2001. Principles of Meat Science. (4<sup>th</sup> edition) Kendall/Hunt, Dubuque, Iowa.
- measures of stress in beef calves. *Journal of animal science* 83 4:933-939.
- Claeys, E., S. De Smet, D. Demeyer, R. Geers, and N. Buys. 2001. Effect of rate of pH decline on muscle enzyme activities in two pig lines. *Meat science* 57:257-263.
- Del Campo, M., G. Brito, J. M. S. de Lima, D. V. Martins, C. Sañudo, R. S. Julián, P. Hernández, and F. Montossi. 2008. Effects of feeding strategies including different proportion of pasture and concentrate, on carcass and meat quality traits in Uruguayan steers. *Meat Science* 80(3):753-760.
- Dikeman, M. E., M. C. Hunt, P. B. Addis, H. J. Schoenbeck, M. Pullen, E. Katsanidis, and E. J. Yancey. 2003. Effects of postexsanguination vascular infusion of cattle with a solution of saccharides, sodium chloride, and phosphates or with calcium chloride on quality and sensory traits of steaks and ground beef. *Journal of Animal Science* 81(1):156-166.
- Duckett, S.K., J. P. S., Neel, J. P., Fontenot, W.M. Clapham, 2009.
- Effects of winter stocker growth rate and finishing system on: III. Tissue proximate, fatty acid, vitamin and cholesterol content. *Journal of Animal Science*, 87, 2961-2970.
- Duckett, S.K., J. P. S., Neel, R. M., Lewis, J. P., Fontenot, W.M. Clapham. 2013.
- Effects of forage species or concentrate finishing on animal performance, carcass, and meat quality. *Journal of Animal Science*, 91, 1454-1467.
- Farouk, M. M., and J. F. Price. 1994. The effect of post-exsanguination infusion on the

- composition, exudation, color and post-mortem metabolic changes in lamb. *Meat Science* 38(3):477-496.
- Fell, L. R., I. G. Colditz, K. H. Walker, and D. L. Watson. 2000. Associations between temperament, performance and immune function in cattle entering a commercial feedlot. *Australian Journal of Experimental Agriculture* 39(7):795-802.
- Fowler, S., J. Claus, and D. Hopkins. 2017. The effect of applying a rinse and chill procedure to lamb carcasses immediately post-death on meat quality? *Meat Science* 134.
- Galbraith J. K. 2011. Meat characteristics and stress of bison slaughtered in a mobile or stationary abattoir. Ph.D. dissertation. University of Alberta, Edmonton, Alberta.
- Herring, H.K., Cassens, R.G., & Briskey, E.J. 1965. Further studies on bovine muscle tenderness as influenced by carcass position, sarcomere length, and fiber diameter. *Journal of Food Science*, 30,1049-1054.
- Hunt, M. C., J. J. Schoenbeck, E. J. Yancey, M. E. Dikeman, T. M. Loughin, and P. B. Addis. 2003. Effects of postexsanguination vascular infusion of carcasses with calcium chloride or a solution of saccharides, sodium chloride, and phosphates on beef display-color stability<sup>1</sup>. *Journal of Animal Science* 81(3):669-675.
- King, D., C. E. Pfeiffer, R. Randel, T. Welsh, R. A. Oliphint, B. E. Baird, K. Curley, R. C. Vann, D. S. Hale, and J. W. Savell. 2006. Influence of animal temperament on stress responsiveness on the carcass quality and beef tenderness of feedlot cattle. *Meat science* 74:546-556.
- Locker, R.H. 1985. Cold-induced toughness of meat. In A.M. Pearson & T.R. Dutson,

Advances in meat research (Vol. 1) (pp. 1-44). Westport, CT, USA: AVI Publishing Co., Inc.

Mickelson, M. A., and J. R. Claus. 2020. Carcass chilling method effects on color and tenderness of bison meat. *Meat Science* 161:108002.

Munck, A., P. M. Guyre, and N. J. Holbrook. 1984. Physiological Functions of Glucocorticoids in Stress and Their Relation to Pharmacological Actions\*. *Endocrine Reviews* 5(1):25-44. doi: 10.1210/edrv-5-1-25

National Bison Association (NBA). 2020. Current Status. Accessed 24 July, 2020  
<https://bisoncentral.com/current-status/>

Pollard, J. C., R. P. Littlejohn, G. W. Asher, A. J. T. Pearse, J. M. Stevenson-Barry, S. K. McGregor, T. R. Manley, S. J. Duncan, C. M. Sutton, K. L. Pollock, and J. Prescott. 2002. A comparison of biochemical and meat quality variables in red deer (*Cervus elaphus*) following either slaughter at pasture or killing at a deer slaughter plant. *Meat Science* 60(1):85-94.

Rioja-Lang, F. C., J. K. Galbraith, R. B. McCorkell, J. M. Spooner, and J. S. Church. 2019. Review of priority welfare issues of commercially raised bison in North America. *Applied Animal Behaviour Science* 210:1-8

Schaefer, A. L., R. W. Stanley, A. K. W. Tong, P. Dubeski, B. Robinson, J. L. Aalhus, and W. M. Robertson. 2006. The impact of antemortem nutrition in beef cattle on carcass yield and quality grade. *Canadian Journal of Animal Science* 86:317-323.

Schaefer, A. L., P. L. Dubeski, J. L. Aalhus, and A. K. W. Tong. 2001. Role of nutrition

- in reducing antemortem stress and meat quality aberrations. *Journal of Animal Science* 79(suppl\_E):E91-E101.
- Sentandreu, M. A., G. Coulis, and A. Ouali. 2002. Role of muscle endopeptidases and their inhibitors in meat tenderness. *Trends in Food Science & Technology* 13(12):400-421.
- Smith, R. F., and H. Dobson. 1990. Effect of preslaughter experience on behaviour, plasma cortisol and muscle pH in farmed red deer.
- Smulders, F.J.M., Toldrá, F., Flores, J., & Prieto, M. 1992. New technologies for meat and meat Products (pp. 182,186-188). Utrecht, The Netherlands: Audet Tijdschriften.
- USDA-APHIS. List of Plants Approved to Receive Immediate Slaughter of Animals. Accessed 21 May, 2020.  
[https://www.aphis.usda.gov/import\\_export/downloads/slaughter\\_list.pdf](https://www.aphis.usda.gov/import_export/downloads/slaughter_list.pdf)
- Warner, R. D., Bond, J. J., & Kerr, M. G. 2000. Meat quality traits in lamb M. Longissimus thoracis et lumborum: The effect of pre-slaughter stress and electrical stimulation. In 46th international congress of meat science and technology (pp. 154–155). Argentina: Buenos Aires.
- Warner, R. D., D. M. Ferguson, J. J. Cottrell, and B. W. Knee. 2007. Acute stress induced by the preslaughter use of electric prodders causes tougher beef meat. *Australian Journal of Experimental Agriculture* 47(7):782-788.
- Wismer-Pedersen, J. 1959. Quality of pork in relation to rate of pH change post mortem. *Journal of Food Science* 24(6):711-727.
- Wulf, D. M., R. S. Emmett, J. M. Leheska, and S. J. Moeller. 2002. Relationships among



glycolytic potential, dark cutting (dark, firm, and dry) beef, and cooked beef palatability<sup>1</sup>. *Journal of Animal Science* 80(7):1895-1903.

Yancey, E., M. E. Dikeman, P. Addist, E. Katsanidis, and M. Pullen. 2002. Effects of vascular infusion with a solution of saccharides; sodium chloride; phosphates; and vitamins C, E, or both on carcass traits, Warner-Bratzler shear force, and palatability traits of steaks and ground beef. *Journal of animal science* 80:1904-1910

**Table 4-1.** Least square means for effects of harvest system on haptoglobin and cortisol serum content of bison heifers.

Serum Analysis	COMMERCIAL <sup>1</sup>	ON-RANCH <sup>1</sup>	SEM <sup>2</sup>	P-value <sup>3</sup>
Cortisol, µg/dL	2.82	0.08	0.330	<.0001
Haptoglobin, µg/mL	22.06	22.01	6.071	.9940

<sup>1</sup>Treatments; COMMERCIAL = grass-finished bison heifers (n=80) transported ~720 km and harvested in a commercial facility. ON-RANCH = grass-finished bison heifers (n=40) harvested on-ranch by a mobile slaughter unit.

<sup>2</sup>Standard error of the mean

<sup>3</sup>Probability of difference among least square means

**Table 4-2.** Least squares means for effect of harvest system on live weight, carcass characteristics, and objective color of bison heifers harvested on-ranch using a mobile slaughter unit or at a commercial packing facility.

Variable	cCOMMERCIAL <sup>1</sup>	ON-RANCH <sup>1</sup>	SEM <sup>2</sup>	P-value <sup>3</sup>
Live weight, kg <sup>4</sup>	378.41	378.39	2.874	.9927
Hot carcass weight, kg	226.44	198.69	3.450	<.0001
Dressing percentage, %	59.81	52.35	1.082	<.0001
Ribeye area, cm <sup>2</sup>	57.48	51.16	0.929	<.0001
12 <sup>th</sup> rib fat thickness, cm	0.89	0.74	0.107	.1105
Marbling score <sup>5</sup>	243.57	295.16	30.899	.0974
Objective Color: ribeye surface <sup>6</sup>				
L*	36.62	34.18	0.833	.0041
a*	23.21	20.85	0.449	<.0001
b*	8.62	5.93	0.224	<.0001
Objective Color: subcutaneous back fat <sup>7</sup>				
L*	77.19	63.67	1.948	<.0001
a*	2.90	20.97	3.470	<.0001
b*	21.92	23.35	0.567	.0129

<sup>1</sup>Treatments: COMMERCIAL = grass-finished bison heifers (n=93) transported ~720 km and harvested in a commercial packing facility. ON-RANCH = grass-finished bison heifers (n=40) harvested on-ranch using a mobile slaughter unit.

<sup>2</sup>Standard error of the mean

<sup>3</sup>Probability of difference among least square means

<sup>4</sup>Live animal weights were recorded on slaughter day for COMMERCIAL and 7 days prior to slaughter for ON-RANCH

<sup>5</sup>Marbling score: 100=Practically Devoid<sup>0</sup>, 200=Traces<sup>0</sup>, 300=Slight<sup>0</sup>

<sup>6</sup>Objective color measurements (L\*, a\*, b\*) recorded at the exposed surface of the ribeye area. L\*: 0 = Black, 100 = White; a\*: negative values = green, positive values = red; b\*: negative values = blue; positive values = yellow

<sup>7</sup>Objective color measurements (L\*, a\*, b\*) recorded at the subcutaneous fat opposite the exposed surface of the ribeye area. L\*: 0 = Black, 100 = White; a\*: negative values = green, positive values = red; b\*: negative values = blue; positive values = yellow

**Table 4-3.** Least squares means for effect of harvest systems on meat quality characteristics of bison *longissimus dorsi*.

Variable	COMMERCIAL <sup>1</sup>	ON-RANCH <sup>1</sup>	SEM <sup>2</sup>	P-value <sup>3</sup>
pH <sup>4</sup>	5.58	5.64	0.015	<.0001
Fat, % <sup>5</sup>	1.94	1.44	0.168	.0045
Moisture, % <sup>6</sup>	75.94	75.22	0.186	.0003
WBSF, kg <sup>7</sup>	2.72	2.37	0.190	.0716
Cook loss, % <sup>8</sup>	22.59	21.42	0.392	<.0001

<sup>1</sup>Treatments; COMMERCIAL = grass-finished bison heifers (n=93) transported ~720 km and harvested in a commercial facility. ON-RANCH = grass-finished bison heifers (n=40) harvested on-ranch by a mobile slaughter unit.

<sup>2</sup>Standard error of the mean

<sup>3</sup>Probability of difference among least square means<sup>†</sup>

<sup>4</sup>Ultimate striploin pH measured at 7, 8, or 9 d postmortem

<sup>5</sup>Proximate crude fat composition expressed as a % of raw tissue from bison *Longissimus dorsi*

<sup>6</sup>Proximate crude moisture composition expressed as a % of raw tissue from bison *longissimus dorsi*

<sup>7</sup>Kg of force measured by texture analyzer with a Warner-Bratzler Shear Force attachment. All steaks used were aged 14 d and stored frozen prior to analysis

<sup>8</sup>Percent of weight loss after cooking. All steaks used were aged 14 d prior to analysis and stored frozen prior to analysis

**Table 4-4.** Least square means for the effect of harvest systems on subjective meat quality attributes rated by a consumer sensory panel (n=113 participants).

Attribute <sup>1</sup>	COMMERCIAL <sup>2</sup>	ON-RANCH <sup>2</sup>	SEM <sup>3</sup>	P-value <sup>4</sup>
Overall liking	78.48	76.01	1.561	.1314
Aroma liking	75.32	71.51	1.883	.0583
Flavor liking	77.68	75.07	1.695	.1411
Texture liking	77.30	76.02	2.002	.5318
Toughness	7.32	6.84	0.470	.2784
Juiciness	9.42	8.67	0.521	.1669
Off-flavor	4.28	4.31	0.411	.9499

<sup>1</sup>Liking ratings were made on 0-120-point labeled affective magnitude scales, with the left most end labeled greatest imaginable disliking and the right most end labeled greatest imaginable liking. Intensity ratings were made on 0-20-point line scales with the left most ends labeled none and the right most ends labeled extremely intense for off-flavor

<sup>2</sup>Treatments; COMMERCIAL = grass-finished bison heifers (n=93) transported ~720 km and harvested in a commercial facility. ON-RANCH = grass-finished bison heifers (n=40) harvested on-ranch by a mobile slaughter unit.

<sup>3</sup>Standard error of the mean

<sup>4</sup>Probability of difference among least square means

## APPENDIX A. CONSUMER SENSORY BALLOT

### Welcome to the Bison Study!

Please click the hand at the top of the page to proceed.

During this session, you will be presented with samples of bison. Please evaluate them one sample at a time.

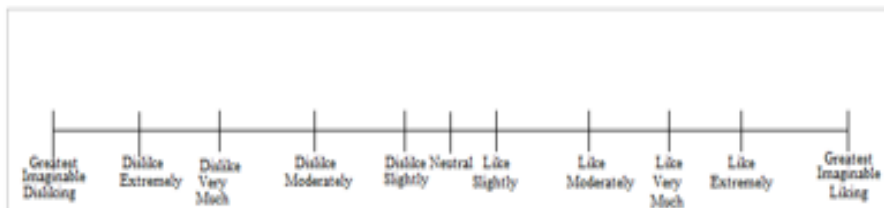
Please always make sure the code of the sample you are evaluating matches the code on the top left of the screen.

**\*\*\*Please pass your panelist ID card through the window to receive your samples\*\*\***

Please click the hand on the top of the screen to proceed once you receive your samples.

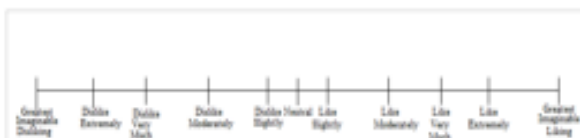
Please open the lid to the sample partway and sniff the aroma of this sample.

Please rate your liking of the aroma

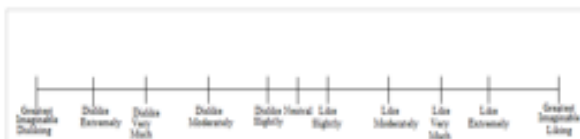


Please eat one bison piece and rate it for the following attributes by placing a mark on each of the scales below.

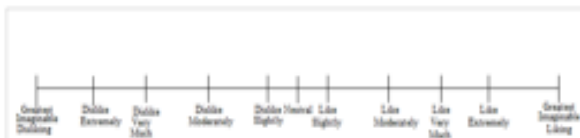
Overall Liking



Flavor Liking

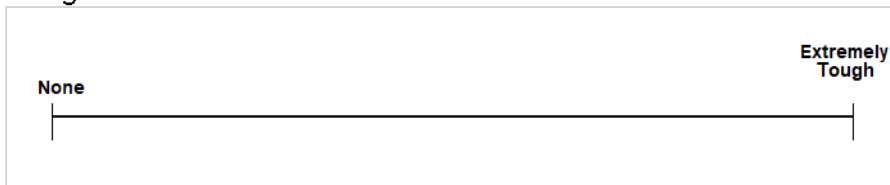


Texture Liking



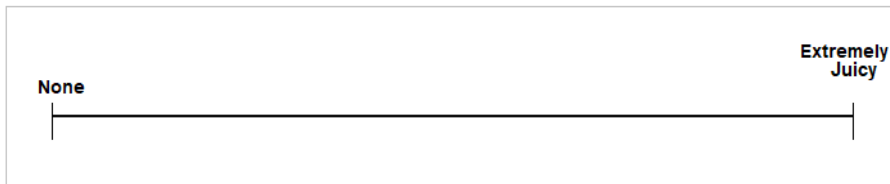
Please eat the second bison piece and rate the intensity of the following attributes.

Toughness



A horizontal line scale for rating Toughness. The left end is labeled "None" and the right end is labeled "Extremely Tough".

Juiciness



A horizontal line scale for rating Juiciness. The left end is labeled "None" and the right end is labeled "Extremely Juicy".

Off-flavor



A horizontal line scale for rating Off-flavor. The left end is labeled "None" and the right end is labeled "Extremely Intense".

Please click the hand on the top of the screen to proceed.

Please describe, as specifically as you can, what this off-flavor was?



A text input field for describing the off-flavor.

Please click next sample at the top of the screen to proceed.

Now that you have tasted three samples of bison, if bison was available at your local grocery store at a reasonable price, would you consider purchasing and consuming it?

- Yes, I would consider purchasing and consuming bison meat as often as I would other meats I regularly buy/consume.
- Yes, I would consider purchasing and consuming bison meat regularly, but not as often as I purchase/consume other meats (chicken, pork, and beef).
- Yes, I would consider purchasing and consuming bison meat occasionally, but much less often as I would consume other meats (chicken, pork and beef).
- No, I would not consider purchasing and/or consuming bison meat.

Which best describes how often you consume meat?

- Weekly
- Monthly
- Yearly
- Never

Have you ever consumed bison before?

- Yes
- No

Please click the hand on the top of the screen to proceed.

How frequently do you consume bison meat?

- I have consumed bison 1 time in my lifetime.
- I have consumed bison 2 - 5 times in my lifetime.
- I have consumed bison 6 or more times in my lifetime.

Please click the hand on the top of the screen to proceed.

What is your gender?

- Female
- Male
- Non-binary/third gender
- Prefer not to answer

Please click the hand on the top of the screen to proceed.

Please click the hand on the top of the screen to proceed.

Please pass your sample tray through the window to receive your compensation.

Please sign the receipt and pass it through the window before leaving.

Thank you for your participation in the Bison Study!



## APPENDIX B. ADDITIONAL CONSUMER SENSORY PANEL RESULTS

**Table B1:** Unedited comments from the question “Please describe, as specifically as you can, what this off-flavor was” (open-ended question) only from those participants that rated the off-flavor intensity as greater than or equal to 10. Each line represents a new participant’s comment

Steak	Comments
	<p><b>fishy</b>            Kind of like <b>blood water</b>.            Some kind of <b>bitterness</b>, didn’t quite taste like meat            Very <b>metallic</b>            The smell combined with tasting dry meat            Was better than before</p>
Grass-finished, on-ranch harvest	<p><b>sour bitter/tarty.</b>            A sort of <b>sour afternote</b> in taste, that is <b>picked up in aroma first</b>            With Sample #505, the off-flavor itself proves quite similar to the            off-flavor with Sample #633. If anything, the flavor type was            more intense and the texture was much less juicy and tougher with            Sample #505 than Samples #633 or #109.            I am not sure            If just left a after taste in my mouth, that tasted a <b>little sour</b>.  <b>Iron or blood</b></p> <hr/> <p>the flavor left in my mouth was a bit unpleasant. not meaty but not            what I expected            Kind of sewer-like towards the end            A little bit <b>sour</b> than the regular steak. Has kind of <b>lamb off-            flavor</b>. Not that strong as steak.            Dry meat            Neutral not much flavor</p>
Grass-finished, commercial harvest	<p>gamey, like free amino acids, slightly <b>rancid and sour</b>            Tastes sort of like <b>liver</b> and I’m not so fond of liver, however the            texture of the bison is 100% better!  <b>THE SAMPLE 109 HAD A VERY STRONG FLAVOR FOR            ME.</b>            A little like to beef jerky, but not as salty as the jerky.            Similar to previous, a sour note that was even a bit more <b>gamey</b> in            this one. I like Bison and expect it to be a little different but this            sample was fairly strong.            The samples had a <b>fishy</b> flavor.</p> <hr/>
Grain-finished, commercial harvest	<p>strong after taste            Just a different flavor.            Just basic meat without any flavor</p>

Somewhat gamey

Flavor **neutral, is like a beef meat**

---

UNPLEASANT FLAVOR, FOUL FLAVOR

Exactly the bison flavor with some **grilled corn** (original flavor).

Slightly overcooked/boiled egg flavor. Initially intense but wore off very quickly.

it was kind of **metallic** tasting

very tender, juicy and taste like steak

Well, this off-flavor to me tasted less fresh, more over-cooked, and with a slight rankness **almost bitter**.

a little **sour taste**.

i didnt like it, i think it could have more flavor, i felt it to be simple and tasteless

A BIT SMOKY, WITH A LITTLE SWEET.

---

**Table B2.** Count of responses to the question, “Now that you have tasted three samples of bison, if bison was available at your local grocery store at a reasonable price, would you consider purchasing and consume it?”

Possible responses	Count of responses
Yes, I would consider purchasing and consuming bison meat as often as I would other meats I regularly buy/consume.	47
Yes, I would consider purchasing and consuming bison meat regularly, but not as often as I purchase/consume other meats (chicken, pork, and beef).	38
Yes, I would consider purchasing and consuming bison meat occasionally, but much less often as I would consume other meats (chicken, pork and beef).	26
No, I would not consider purchasing and/or consuming bison meat.	2

## APPENDIX C: CONSUMER SENSORY PARTICIPANT DEMOGRAPHICS

**Table C1.** Which best describes how often you consume meat?

Meat consumption	No. of participants
Weekly	107
Monthly	5
Yearly	1
Never	0

**Table C2.** Have you ever consumed bison before?

Consumed bison before	No. of participants
Yes	83
No	30

**Table C3.** How frequently do you consume bison meat?

Lifetime bison consumption	No. of participants*
I have consumed bison 1 time	9
I have consumed bison 2 -5 times	45
I have consumed bison 6 or more times	29

\*This question was only displayed if participant indicated having consumed bison before.

**Table C4.** Consumer Sensory Participant Gender

Gender	No. of participants*
Male	27
Female	54
Non-binary/third gender	0
Prefer not to answer	0

\*This question was only displayed if participant indicated having consumed bison before.