

South Dakota State University

Open PRAIRIE: Open Public Research Access Institutional Repository and Information Exchange

Electronic Theses and Dissertations

1972

A Study of Underground Cable as Applied to a Single-phase Circuit and a Paralleled Overhead-underground Single-phase Circuit

Eugene A. Christianson

Follow this and additional works at: <https://openprairie.sdstate.edu/etd>

Recommended Citation

Christianson, Eugene A., "A Study of Underground Cable as Applied to a Single-phase Circuit and a Paralleled Overhead-underground Single-phase Circuit" (1972). *Electronic Theses and Dissertations*. 4640.

<https://openprairie.sdstate.edu/etd/4640>

This Thesis - Open Access is brought to you for free and open access by Open PRAIRIE: Open Public Research Access Institutional Repository and Information Exchange. It has been accepted for inclusion in Electronic Theses and Dissertations by an authorized administrator of Open PRAIRIE: Open Public Research Access Institutional Repository and Information Exchange. For more information, please contact michael.biondo@sdstate.edu.

A STUDY OF UNDERGROUND CABLE AS APPLIED TO A SINGLE-PHASE CIRCUIT
AND A PARALLELED OVERHEAD-UNDERGROUND SINGLE-PHASE CIRCUIT

BY

EUGENE A. CHRISTIANSON

A thesis submitted
in partial fulfillment of the requirements for the
degree Master of Science, Major in
Electrical Engineering,
South Dakota State University

1972

A STUDY OF UNDERGROUND CABLE AS APPLIED TO A SINGLE-PHASE CIRCUIT
AND A PARALLELED OVERHEAD-UNDERGROUND SINGLE-PHASE CIRCUIT

This thesis is approved as a creditable and independent investigation by a candidate for the degree, Master of Science, and is acceptable for meeting the thesis requirements for this degree. Acceptance of this thesis does not imply that the conclusions reached by the candidate are necessarily the conclusions of the major department.

Wayne E. Knabach
Thesis Advisor

Date

F. C. Fitchen, Head
Electrical Engineering Department

Date

ACKNOWLEDGEMENTS

The author wishes to thank Professor Knabach for his guidance and advice in the preparation of this thesis, Sioux Valley Empire Electric Association for their contribution of men and equipment, and The Center for Power System Studies for their financial assistance during the author's graduate work. The author also wishes to thank his wife for her patience, understanding, and hard work during his graduate studies.

EAC

TABLE OF CONTENTS

CHAPTER	PAGE
I. INTRODUCTION	1
II. REVIEW OF LITERATURE	3
III. DEVELOPMENT OF THE INDUCTANCE FORMULAS FOR AN UNDERGROUND CIRCUIT ALONE AND AN OVERHEAD-UNDERGROUND PARALLEL CIRCUIT	15
IV. DEVELOPMENT OF THE CAPACITANCE FORMULAS FOR AN UNDERGROUND CIRCUIT ALONE AND AN OVERHEAD-UNDERGROUND PARALLEL CIRCUIT	40
V. THE DETERMINATION OF AN EQUIVALENT CIRCUIT AND THE CALCULATION OF THE CIRCUIT PARAMETERS	51
VI. DERIVATION OF THE CIRCUIT IMPEDANCE OF A SINGLE-PHASE UNDERGROUND CIRCUIT WITH EARTH-RETURN AND A PARALLELED SINGLE- PHASE UNDERGROUND-OVERHEAD CIRCUIT	68
VII. DISCUSSION OF THE RESULTS	77
APPENDIX A	85
APPENDIX B	95
REFERENCES	106

Chapter I

INTRODUCTION

Growing concern for the preservation of the natural beauty of this country has spurred the development of underground cable. Overhead circuits, which once cluttered the landscape, are being retired and underground circuits are being installed. At new development sites, whether rural or urban, the question of installing underground circuits is being considered.

The advantage of added beauty is not the only favorable consideration for underground distribution systems. In the Midwest, the unpredictable weather often becomes a formidable opponent of the electric utility. Since the underground cable is buried in the earth, the hazards of wind, ice, and lightning are either eliminated or reduced considerably. The added advantage of service quality is augmented by the increased safety of underground systems. There are no poles to be struck by out-of-control vehicles, no live wires lying on the ground to endanger citizens, and no overhead lines to be snagged by large equipment.

However, to simply state the advantages of underground distribution systems would be misleading. There are disadvantages which, through added research, hopefully can be resolved. The major disadvantage in employing underground systems is cost. To simply revise all of the existing overhead systems by installing underground systems would virtually be an impossibility. Therefore, if there is to be a revision of existing systems, it will have to be a gradual process. The other

disadvantage of underground distribution is its inaccessibility in case of a fault. Research is being carried out to develop new methods of fault location. Once these methods are established, part of the problem of inaccessibility can be reduced.

Research in the area of underground cable is an expanding field. The never-ending goal of decreasing the cost of cable has resulted in various new designs. The concentric neutral underground cable is one of these designs.

The purpose of this thesis is to make a study of a single-phase underground circuit comprised of this concentric neutral cable, and a study of a single-phase underground system that is physically paralleled with a single-phase overhead circuit. Formulas will be developed for the inductance and capacitance of each of these cases. These formulas will be developed, based on the assumption that all of the phase current returns in the neutral conductor. An equivalent circuit will be proposed for each of these cases, and numerical values for each of the circuit parameters will be calculated. Finally, solutions will be obtained using formulas which take into account the earth-return path. Values which are obtained from these formulas will be checked with data measured in the field.

Chapter II

REVIEW OF LITERATURE

Electrical characteristics of cables are dictated by the type, configuration, and application of the cable. Through the years, the physical construction of cables has changed considerably. These changes were brought about due to the need for increasing voltage levels, higher current carrying capacities, more desirable mechanical characteristics, and more economical products. Through these transitions, the electrical characteristics have been altered. Modifications of the electrical characteristics affect the circuit parameters which comprise the equivalent circuit. Therefore, it is valuable to examine the development of these cables and review the theory behind the parameters of the equivalent circuit.

Depending on geographical location, early cables were insulated with rubber or paper. In the United States, local legislation sometimes imposed restrictions on trenching, limiting it to an authority. The ducts provided by this authority were not necessarily designed for electrical circuitry. For this reason, rubber insulated cables, which were very flexible, were used extensively. In other parts of the world, wound paper insulation was chiefly adopted. Impregnated paper insulation, though offering a more rigid construction, posed no particular problem, since direct burial procedures were common.

World War I marked the successful introduction of the belted cables. These cables were made up of three conductors which were separately insulated and wrapped with an impregnated paper. The entire

assembly was then surrounded by a lead sheath. These cables were very good at voltages of 22 kV and below, but proved to be a dismal failure at higher voltages. The failure of the belted cable, due to longitudinal electric stresses acting on the relatively weak paper, was corrected with the introduction of a cable designed by Hochstadter. This new design incorporated conducting core shields which surrounded each core, thus establishing a radial field with respect to both the earth and the phase voltages. Hochstadter's cable is better known as the H-type cable.¹

With an increase in voltage levels, problems such as the formation of voids in the insulation and non-uniform dielectric quality spurred the development of the oil-filled and gas-pressure cables. One of the advantages of the oil-filled cables was that the insulation thickness could be decreased. Another advantage was that moisture could not penetrate the insulation, thus causing an insulation failure. Both the oil-filled cable and the gas-pressure cable are still being used at higher voltage levels. These voltage levels are now ranging to over 500 kV.²

Extensive research in the area of direct buried cable was initiated due to the increasing development and high cost of underground distribution in the United States. Much of the work was done in the field of insulation. As mentioned before, rubber was used extensively in the United States because it was flexible and had acceptable insulating characteristics. However, rubber had the tendency to absorb moisture and had to be jacketed with lead or treated with fibrous materials. The lead sheath, while providing moisture protection, also added

physical protection for installation and supplied an electrostatic shield. Unfortunately, disadvantages such as shield current, non-flexibility, and high cost, overshadowed these advantages.

World War II stimulated research with synthetic rubbers. Out of this research, butyl was found to have excellent dielectric properties as well as temperature stability. However, like natural rubber, butyl had to be jacketed. Another synthetic, neoprene, was discovered to be a very good jacketing material. Neoprene was found to have excellent mechanical characteristics. Unfortunately, its use was limited due to a high cost of production.³

Until this time, the lead-sheathed cable was primarily used. However, because of cost and the development of underground distribution, a new type of cable was introduced. This was the concentric neutral cable. The original concentric neutral cable, developed for single phase distribution on a multi-grounded neutral wye-type system, was rubber insulated. It was a #6 AWG copper phase conductor with an unshielded neoprene covering or jacket over the rubber insulation. Wound concentrically around the jacket, were six #14 AWG wires which acted as the neutral return path.⁴

The concentric neutral cables were introduced in the late 1940's. In the 1950's, the development of plastics proved to be vital to the cable industry. Of all the plastics to be developed, polyethylene has turned out to be the best. Polyethylene not only has fine electrical characteristics, but also possesses outstanding mechanical characteristics. Unlike rubber, polyethylene absorbs practically no moisture and is very tough.

Polyethylene can be subdivided into two categories--high-molecular weight and crosslinked polyethylene. Both of these polyethylenes are thermo-plastic compounds. However, high-molecular weight polyethylene is cured by cooling, while crosslinked polyethylene is cured by heating. The main difference between these two insulations is the maximum allowable conductor temperature ratings. High-molecular weight polyethylene has a conductor temperature rating of 75 degrees C, while crosslinked polyethylene has a conductor temperature rating of 90 degrees C.³

The outstanding qualities that these new insulations possessed were immediately used in the development of a new cable. This cable was called underground distribution (UD) or underground residential distribution (URD), and was comprised of a stranded or solid conductor, an extruded semiconducting shield, a polyethylene insulation, a semiconducting polyethylene layer, and a concentrically annealed copper neutral. Here again, the polyethylene insulation may be crosslinked or high-molecular weight, depending on the anticipated conductor temperature.³

Electric cables have been modified, improved, and adapted for various applications since their introduction. The basic laws governing the solution of electric circuits have not been altered. However, the parameters which are integral to the equivalent circuits have been modified. The following discussion examines the early theory proposed for cables and the alterations involved in switching to underground distribution.

Most of the theoretical work developed in conjunction with cables was presented in the early years of this century. Early investigators in cable theory were Dr. J. R. Carson and Dr. Reinhold Rüdenberg.

Carson published a significant paper, in 1926, entitled "Wave Propagation in Overhead Wires With Ground Return".⁵ Since this paper directly included the ground return, Carson recognized the problem of current distribution through the earth. This problem exists because of the nonuniformity of the earth and the lack of conductive homogeneity. To alleviate these obstacles, Carson assumed that the earth was a plane of homogeneous semi-infinite solid material.

He considered the earth to be a plane parallel to the conductors. Using a three dimensional system, the X-Z plane corresponded to the earth's surface. The conductor and conductor image were positioned on the y-axis, equidistant from the origin. For $y > 0$, the conductivity, λ , was assumed to be zero, and for $y < 0$, the conductivity was assigned a finite value dependent on soil conditions, which were determined from field tests.

Carson not only derived an expression for the wave propagation constant, γ , but also derived the relations, later to become Carson's formulas. These formulas describe the self-impedance with earth-return and the mutual impedance with common earth-return. These equations, stated in a general form, are

$$Z_{aa-g} = (r_c + R_{aa-g}) + j(x_i + X_{aa-g}) \quad (2-1)$$

and

$$Z_{ab-g} = R_{ab-g} + jX_{ab-g} \quad (2-2)$$

where

r_c = conductor resistance in nanoohms per centimeter

x_i = conductor internal reactance in nanoohms per centimeter

R_{aa-g} = resistance of the component of self-impedance with earth-return external to the conductor in nanoohms per centimeter

X_{aa-g} = reactance of the component of self-impedance with earth-return external to the conductor in nanoohms per centimeter

R_{ab-g} = resistance of the mutual impedance with common earth-return between two conductors in nanoohms per centimeter

X_{ab-g} = reactance of the mutual impedance with common earth-return between two conductors in nanoohms per centimeter.

The internal impedance of the self-impedance may be assumed to be given by the resistance of the conductor.⁵ With this in mind, the parameters which constitute Carson's formulas are

r_c = conductor resistance in nanoohms per centimeter

R_{aa-g} = $4\omega P$ in nanoohms per centimeter

R_{ab-g} = $4\omega P$ in nanoohms per centimeter

X_{aa-g} = $2\omega \log_e \frac{4h_a}{d} + 4\omega Q$ in nanoohms per centimeter

X_{ab-g} = $2\omega \log_e \frac{S_{ab}}{s_{ab}} + 4\omega Q$ in nanoohms per centimeter

where

f = frequency in Hertz -

h = height above ground of the conductor in centimeters

d = diameter of the conductor in centimeters

s = distance between conductors in centimeters

S = distance from one conductor to the image of the other, assuming a perfectly conducting earth, in centimeters

$$\omega = 2\pi f$$

P = resistive correction factor

Q = reactive correction factor⁶.

Carson's formulas were originally developed for use in overhead cable design. These equations may be adapted to underground cable by assuming the height of the conductor above the earth to be equal to zero. This assumption can be made if the self- and mutual impedances of cables with earth-returns are essentially the same value below the ground as they are at the earth's surface.⁷ The latter assumption can be made as a result of a paper published in 1929.⁸ This paper indicated that if a conductor was placed reasonably close to the surface of the earth, the deviation from the circular symmetry of earth in all directions had little effect on the impedance. The circular symmetry referred to in this case, dealt with the finite distance of soil above the conductor, in respect to the infinite distance below the conductor. The deviation from the circular symmetry was so small that Carson stated that the correction factor developed in his paper might not be justified.

Like Carson, Dr. Reinhold Rüdenberg assumed that the earth has a uniform resistivity ρ . However, Rüdenberg attacked the self- and mutual impedance problem from a different viewpoint. Rüdenberg assumed that a conductor of diameter "d", whether overhead at a distance "h" above the earth's surface, or underground at a distance "h" from the surrounding earth, could be replaced by a conductor of

diameter "d" in a semicircular trough in the earth of radius "h".⁶ The radius "h" of the semicircular trough corresponds directly to the height of the cable above ground or to the radius of the sheath of a cable directly buried in the earth.

Rüdenberg's equation for self-impedance of a conductor takes into account not only the impedance due to the flux in the earth, but also the impedance due to the flux within the trough mentioned above. The equation for self-impedance with earth-return was given as

$$Z_{aa-g} = (r_c + \pi^2 f) + j(2\omega \log_e \frac{0.178 \sqrt{\rho}}{d_a} + x_i) \quad (2-3)$$

where

r_c = resistance of the conductor

f = frequency in Hertz

d_a = diameter of the conductor

x_i = internal reactance of the conductor.

The equation for the mutual impedance with a common earth-return consists of the impedance due to the flux in the earth and the impedance due to the flux within the trough. This equation was given as

$$Z_{ab-g} = \pi^2 f + j2\omega \log_e \frac{0.178 \sqrt{\rho}}{s_{ab}} \quad (2-4)$$

where s_{ab} was the spacing between the centers of the conductors.⁶

As might be expected, Rüdenberg's equations show an independence from the height or the depth of the cable. Comparison of Rüdenberg's and Carson's work shows only an increase in the reactance term of

Carson's formula. This increase is only 0.019 for a frequency of 60 Hz. Essentially, this showed that their work could be used for underground, as well as for overhead systems.

M. C. Gray proposed a derivation for both finite and infinite power lines which deviated from that of Rüdenberg and Carson.^{9,10} Gray's work differed from that of Rüdenberg and Carson in that he did not assume the earth to be uniformly conducting. Instead, Gray made the assumption that the conductivity of the earth varies exponentially as the depth increases. This assumption was given as

$$\lambda = \lambda_0 e^{-bz} \quad z \leq 0 \quad (2-5)$$

where λ_0 was the conductivity at the surface of the earth, which was the X-Y plane.

Mayr proposed that the earth be replaced by a thin conducting surface layer. Haberland, Riordan and Sunde studied the idea of two-layer horizontal stratification with a thin surface layer. The two-layer stratification has been extended to three layers, but an accurate study of soil conditions must be available to use these ideas.¹¹

With the advent of the concentric neutral cable, the equations developed by the people previously mentioned, had to be adapted to the new cables. R. C. Ender published a recent paper updating these formulas.¹² Ender simply adapted Carson's formulas for use in underground distribution and extended them to take care of the concentric neutral. The derivations for these formulas will be developed in the appendix.

F. C. Van Wormer published a paper in 1967 dealing with approximate impedance calculations for underground cables.¹³ Van Wormer made several assumptions which allowed him to simplify the impedance equations, and at the same time, yield sufficient accuracy. The first of these assumptions was that all of the current in the phase conductor would return in the neutral conductor. This meant that the impedance of the earth could be neglected. The second assumption was that the current was distributed uniformly in the phase and neutral conductors. This assured a uniform magnetic field. Van Wormer further assumed that the concentric neutral strands, which make up the total return circuit, could be approximated by a very thin continuous shell. As a result, Van Wormer stated that the impedance of the return circuit consisted only of the resistance of the neutral strands.

Like Van Wormer, D. L. Stone assumed that the concentrically wound neutral could be represented by a thin shell.¹⁴ However, Stone considered two cases: (1) earth neglected, and (2) earth considered. By neglecting the earth, all of the current in the phase conductor is assumed to return in the neutral conductor. The equations that resulted were similar to those of Van Wormer. Stone proposed that the impedance of the earth could be taken into account by paralleling the neutral impedance and the earth's impedance. In order to obtain the total impedance of the circuit, the phase conductor impedance would have to be added in series with the parallel combination. This is expressed as

$$Z = Z_p + \frac{Z_n Z_e}{Z_n + Z_e} \quad (2-6)$$

where

$$Z_p = R_p + j.004657f \log (h/\text{GMR}) \text{ in ohms/mile}$$

$$Z_n = R_n + j0.0 \text{ in ohms/mile}$$

$$Z_e = .00159f + j.004657f \log(D_e/h) \text{ in ohms/mile}$$

$$R_p = \text{phase conductor resistance in ohms/mile}$$

$$f = \text{frequency in Hertz}$$

GMR = geometric mean radius of the phase conductor in feet

h = distance from the center of the phase conductor to the center of the neutral in feet

R_n = neutral resistance in ohms/mile

$$D_e = 2160 \sqrt{\frac{\rho}{f}}$$

= earth resistivity in meter-ohms.

Stone concluded that neglecting the effect of the earth-return resulted in a considerable error for small cable sizes. However, a graph that was presented for a #4/0 AWG cable showed that this error was not as great for larger cable diameters.

J. V. Barger and D. R. Smith presented a paper in October, 1971, at the IEEE 1971 Conference on Underground Distribution.¹⁵ This paper dealt with two methods of solving for the series impedance of the combined circuit. Each of these methods required the application of Carson's formulas, which were adapted for use with underground cables. One of the methods presented made use of the uniform, thin sheath representation of the concentric neutral. In this case, the mutual impedance between each strand need not be considered. The second method considered each strand separately. This meant that the mutual

impedance between each strand must be calculated. Smith and Barger concluded that there was not an appreciable error between the final results of these two methods.

Chapter III

DEVELOPMENT OF THE INDUCTANCE FORMULAS FOR AN UNDERGROUND CIRCUIT
ALONE AND AN OVERHEAD-UNDERGROUND PARALLEL CIRCUIT

Concentric neutral cable is being widely accepted by the electric utility industry as a primary supply circuit to underground residential distribution systems.¹³ An illustration of this cable is shown in figure (3-1). The concentric neutral consists of strands of #14 AWG annealed copper. The number of strands comprising the neutral normally depends on the size of the phase conductor. A rule of thumb dictates that the return path should be capable of handling as much current as the phase conductor.¹² This means that for a three phase system, the number of strands can be reduced to provide approximately one-third of the circular mil area of one of the phase conductors. However, the Rural Electrification Administration has specified a reduced neutral for single-phase as well as for three phase systems.¹⁶ This can be specified since only part of the phase current returns in the neutral conductor. The remainder of the return current uses the earth as a conducting path. The formulas developed in this chapter are based on a reduced neutral for a single-phase system. These formulas are: (1) the inductance and inductive reactance for underground cables alone, and (2) the inductance and inductive reactance for parallel overhead-underground circuits.

The equations to be developed for both the underground circuit alone and the paralleled underground-overhead circuit are based on the same basic assumptions. First, the current density in the phase

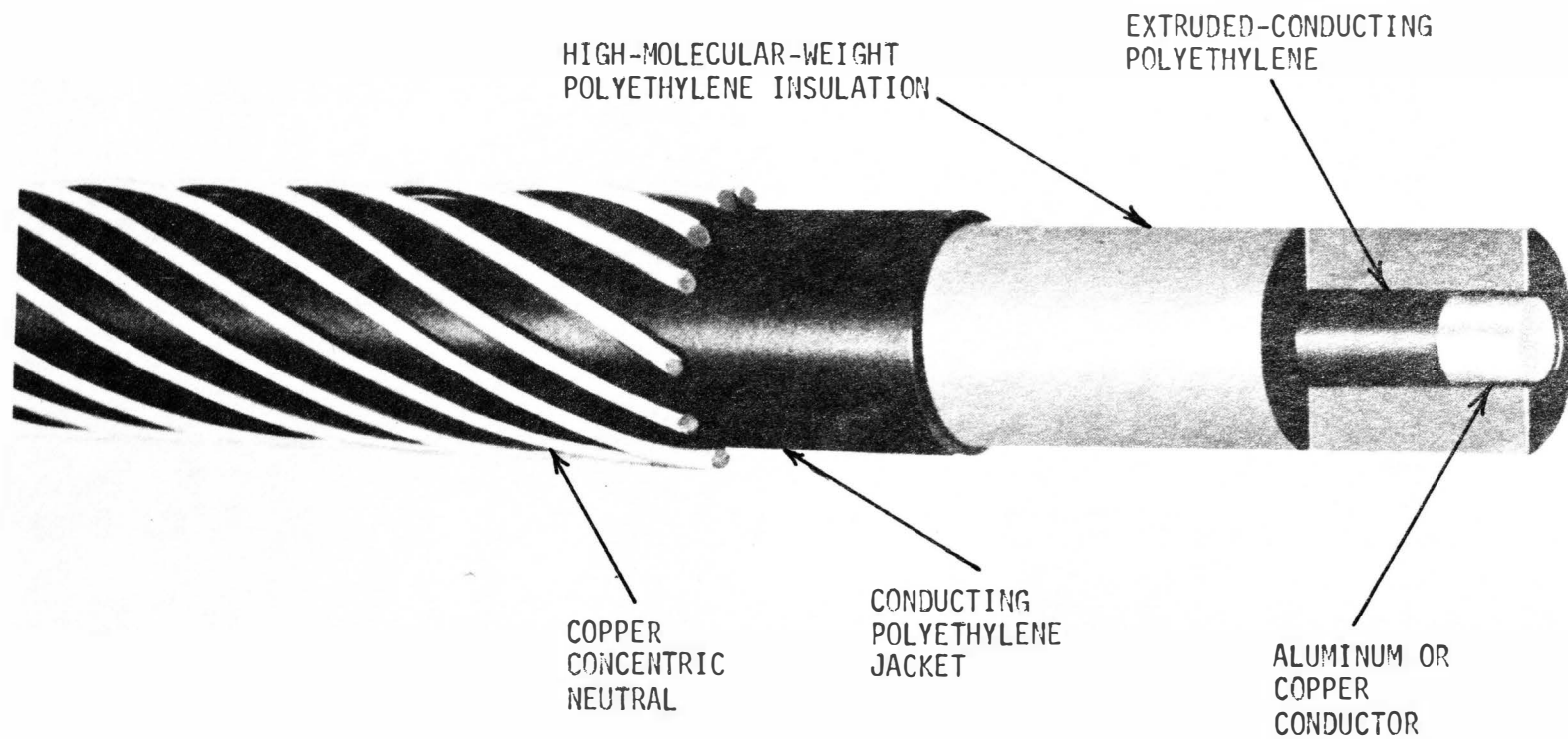

Figure (3-1)

ILLUSTRATION OF A CONCENTRIC NEUTRAL CABLE

conductor and the neutral conductor is constant. It is also assumed that all of the current in the phase conductor returns in the concentric neutral. Since each of the strands comprising the neutral return is identical and electrically in parallel, the return current splits equally between each strand of the neutral.

The underground single-phase circuit is similar to the overhead single-phase circuit in that both have a phase conductor and a neutral return. The phase conductor of the underground circuit will be designated as conductor 3. The neutral return conductor, consisting of "s" number of strands, will be designated as conductor 4. Each strand of the neutral return will be designated by a small letter as follows: a, b, c, d, e, and f. Figure (3-2) shows a cross section of a concentric neutral cable. The lines connecting the center of each strand illustrate a geometric distance given by a capital letter "D", with subscripts indicating the strands or conductors being described. Thus, D_{ab} represents a distance between the centers of strand "a" and strand "b" of conductor 4. D_{a3} represents a distance between the center of strand "a" of conductor 4 and the center of the solid conductor 3.

The same procedures developed in Appendix A are used in developing an expression for the inductance of an underground cable. In order to calculate the total inductance of a single-phase circuit, the inductance of each conductor must be considered. The inductance of each conductor depends on the flux linkages which describe the magnetic field. The expression shown in Appendix A, which relates the flux linkages and inductance of a conductor, is given as

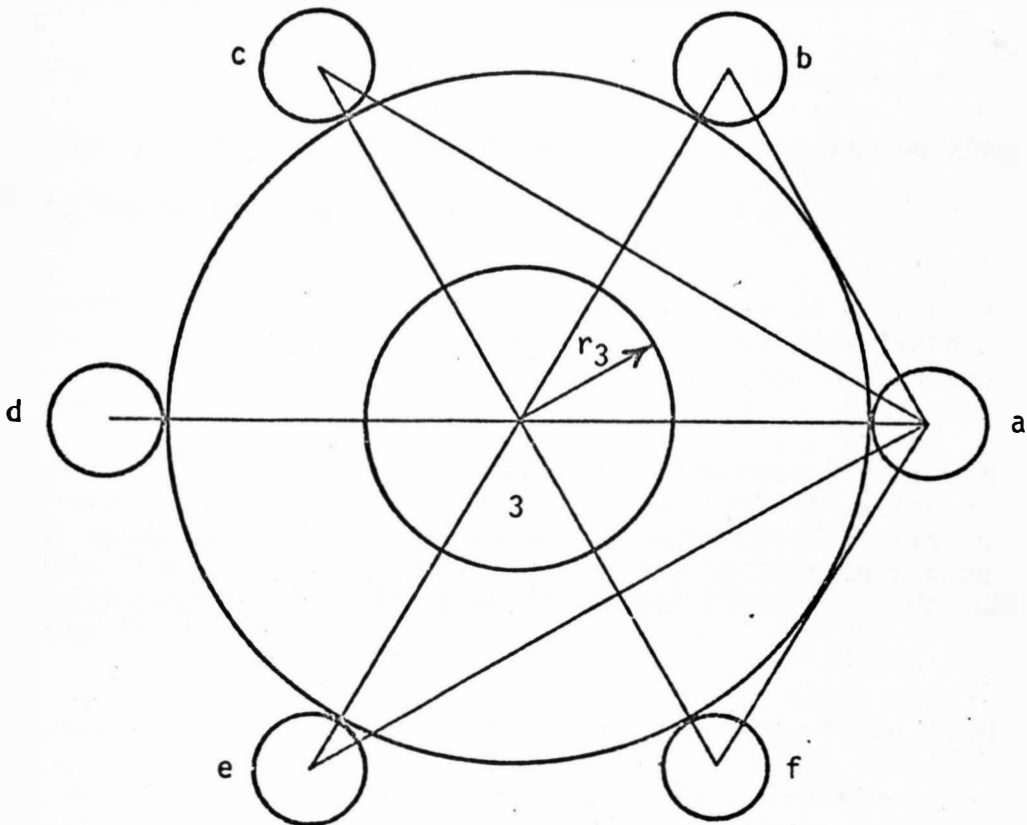

Figure (3-2)

GEOMETRIC DISTANCES USED TO DETERMINE
THE INDUCTANCE OF AN UNDERGROUND CABLE

$$L = \frac{\psi}{I} \quad \text{henrys/meter,} \quad (3-1)$$

where ψ represents the total flux linkages of a conductor in weber-turns and I represents the current in the conductor in amps.¹⁷ Therefore, the total flux linkages of the conductor, both internal and external, must be defined in order to derive an expression for an equivalent inductance.

The inductance of conductor 3 will be considered first. The total flux linkages, which describe the magnetic field about the phase conductor, can be given as

Total flux linkages = Internal flux linkages of conductor 3 due to the current in conductor 3 + external flux linkages of conductor 3 due to the current in conductor 3 + external flux linkages of conductor 3 due to the current in strand "a" + external flux linkages of conductor 3 due to the current in strand "b" + external flux linkages of conductor 3 due to the current in strand "c" + external flux linkages of conductor 3 due to the current in strand "d" + external flux linkages of conductor 3 due to the current in strand "e" + external flux linkages of conductor 3 due to the current in strand "f".

The currents in each strand of the concentric neutral are opposite in direction of the phase conductor current. This direction is considered by inserting a minus sign in the expression for the flux linkages when considering the return currents. Initially, the flux linkages can be written as

$$\begin{aligned}
\int d\psi_3 = & \frac{I_3}{2} \times 10^{-7} + \frac{\mu I_3}{2\pi} \int_{r_3}^{D_{3q}} \frac{dx}{x} - \frac{\mu I_4}{2\pi s} \int_{D_{3a}}^{D_{aq}} \frac{dx}{x} - \frac{\mu I_4}{2\pi s} \int_{D_{3b}}^{D_{bq}} \frac{dx}{x} \\
& - \frac{\mu I_4}{2\pi s} \int_{D_{3c}}^{D_{cq}} \frac{dx}{x} - \frac{\mu I_4}{2\pi s} \int_{D_{3d}}^{D_{dq}} \frac{dx}{x} - \frac{\mu I_4}{2\pi s} \int_{D_{3e}}^{D_{eq}} \frac{dx}{x} \\
& - \frac{\mu I_4}{2\pi s} \int_{D_{3f}}^{D_{fq}} \frac{dx}{x} \tag{3-2}
\end{aligned}$$

where "s" represents the number of strands which comprise conductor 4, and "q" is some finite point in space. Integrating equation (3-2), and combining the internal and external components of flux linkages, as is done in Appendix A, yields

$$\begin{aligned}
\psi_3 = & 2 \times 10^{-7} \left(I_3 \log_e \frac{D_{3q}}{r_3'} - \frac{I_4}{s} \log_e \frac{D_{aq}}{D_{3a}} - \frac{I_4}{s} \log_e \frac{D_{bq}}{D_{3b}} \right. \\
& \left. - \frac{I_4}{s} \log_e \frac{D_{cq}}{D_{3c}} - \frac{I_4}{s} \log_e \frac{D_{dq}}{D_{3d}} - \frac{I_4}{s} \log_e \frac{D_{eq}}{D_{3e}} - \frac{I_4}{s} \log_e \frac{D_{fq}}{D_{3f}} \right) . \tag{3-3}
\end{aligned}$$

Combining terms, equation (3-3) becomes

$$\psi_3 = 2 \times 10^{-7} \left(I_3 \log_e \frac{D_{3q}}{r_3'} - I_4 \log_e \frac{(D_{aq} D_{bq} D_{cq} D_{dq} D_{eq} D_{fq})^{1/s}}{(D_{3a} D_{3b} D_{3c} D_{3d} D_{3e} D_{3f})^{1/s}} \right).$$

(3-4)

The logarithm of the product of two quantities can be expressed as the sum of the natural logarithms of the quantities. Applying this statement to equation (3-4) yields

$$\psi_3 = 2 \times 10^{-7} \left(I_3 \log_e D_{3q} + I_3 \log_e \frac{1}{r_3'} - I_4 \log_e (D_{aq} D_{bq} D_{cq} D_{dq} \right.$$

$$\left. D_{eq} D_{fq} \right)^{1/s} - I_4 \log_e \frac{1}{(D_{3a} D_{3b} D_{3c} D_{3d} D_{3e} D_{3f})^{1/s}} \right). \quad (3-5)$$

Since the return current in conductor 4 is equal in magnitude to the phase current in conductor 3, and the difference of two natural logarithms can be expressed as the logarithm of a quotient, equation (3-5) can be rewritten as

$$\psi_3 = 2 \times 10^{-7} \left(I_3 \log_e \frac{(D_{3a} D_{3b} D_{3c} D_{3d} D_{3e} D_{3f})^{1/s}}{r_3'} \right.$$

$$\left. + I_3 \log_e \frac{D_{3q}}{(D_{aq} D_{bq} D_{cq} D_{dq} D_{eq} D_{fq})^{1/s}} \right).$$

(3-6)

As the point "q" moves farther away from the conductor, the ratio of

$\frac{D_{3q}}{(D_{aq}D_{bq}D_{cq}D_{dq}D_{eq}D_{fq})^{1/s}}$ approaches unity. Since the natural logarithm of unity is zero, the latter term of equation (3-6) has no effect on the inductance of conductor 3. The flux linkages of conductor 3 are written as

$$\psi_3 = 2 \times 10^{-7} I_3 \log_e \frac{(D_{3a}D_{3b}D_{3c}D_{3d}D_{3e}D_{3f})^{1/s}}{r_3'} \quad \text{weber-turns.} \quad (3-7)$$

Substituting equation (3-7) into equation (3-1) results in the expression for the inductance of conductor 3, which is

$$L_3 = 2 \times 10^{-7} \log_e \frac{(D_{3a}D_{3b}D_{3c}D_{3d}D_{3e}D_{3f})^{1/s}}{r_3'}. \quad (3-8)$$

The above expression is the inductance of conductor 3, if it is a solid conductor.

The inductive reactance of a conductor can be written as

$$X_L = 2\pi fL \quad \text{ohms/meter} \quad (3-9)$$

where f is the frequency in Hertz. Substituting equation (3-8) in equation (3-9) yields

$$X_{L3} = 2\pi f (2 \times 10^{-7}) \log_e \frac{(D_{3a}D_{3b}D_{3c}D_{3d}D_{3e}D_{3f})^{1/s}}{r_3'}, \quad (3-10)$$

which simplifies to

$$X_{L3} = 4\pi f \times 10^{-7} \log_e \frac{(D_{3a}D_{3b}D_{3c}D_{3d}D_{3e}D_{3f})^{1/s}}{r'_3} \quad \text{ohms/meter.} \quad (3-11)$$

Equation (3-11) represents the inductive reactance of conductor 3 in ohms/meter.

The inductance of conductor 4 is dependent on deriving an expression for each strand of "s" strands which comprise the conductor. An expression for strand "a" will be developed and extended to give an equation for the inductance of the reduced concentric neutral. The same principles can be applied here as were applied previously. Since all of the current in the phase conductor is assumed to return in the neutral, the current in each strand is equal to $\frac{I_4}{s}$.

The expression for the flux linkages of strand "a" of conductor 4 is

Flux linkages of strand "a" = Internal flux linkages of strand "a" due to the current in strand "a" + external flux linkages of strand "a" due to the current in strand "b" + external flux linkages of strand "a" due to the current in strand "c" + external flux linkages of strand "a" due to the current in strand "d" + external flux linkages of strand "a" due to the current in strand "e" + external flux linkages of strand "a" due to the current in strand "f" + external flux linkages of strand "a" due to the current in conductor 3.

This expression is rewritten in integral form and appears as

$$\begin{aligned}
\int d\psi_a = & \frac{I_4}{2s} \times 10^{-7} + \frac{\mu I_4}{2\pi s} \int_{r_a}^{D_{aq}} \frac{dx}{x} + \frac{\mu I_4}{2\pi s} \int_{D_{ab}}^{D_{bq}} \frac{dx}{x} + \frac{\mu I_4}{2\pi s} \int_{D_{ac}}^{D_{cq}} \frac{dx}{x} \\
& + \frac{\mu I_4}{2\pi s} \int_{D_{ad}}^{D_{dq}} \frac{dx}{x} + \frac{\mu I_4}{2\pi s} \int_{D_{ae}}^{D_{eq}} \frac{dx}{x} + \frac{\mu I_4}{2\pi s} \int_{D_{af}}^{D_{fq}} \frac{dx}{x} \\
& - \frac{\mu I_3}{2\pi} \int_{D_{a3}}^{D_{3q}} \frac{dx}{x}, \tag{3-12}
\end{aligned}$$

where the algebraic signs are the result of the relative direction of the flux linkages. Integrating equation (3-12) and combining like terms gives

$$\psi_a = 2 \times 10^{-7} \left(I_4 \log_e \frac{(D_{aq} D_{bq} D_{cq} D_{dq} D_{eq} D_{fq})^{1/s}}{(r'_a D_{ab} D_{ac} D_{ad} D_{ae} D_{af})^{1/s}} - I_3 \log_e \frac{D_{3q}}{D_{a3}} \right) \tag{3-13}$$

where $r'_a = r_a e^{-\frac{1}{4}}$. Remembering that the total current in both conductors is equal in magnitude, and applying the proper rules in simplifying the logarithmic expression, a new expression for ψ_a results. This new expression becomes

$$\psi_a = 2 \times 10^{-7} \left(I_4 \log_e \frac{D_{a3}}{(r'_a D_{ab} D_{ac} D_{ad} D_{ae} D_{af})^{1/s}} + I_4 \log_e \frac{(D_{aq} D_{bq} D_{cq} D_{dq} D_{eq} D_{fq})^{1/s}}{D_{3q}} \right), \quad (3-14)$$

where the quotient $\frac{(D_{aq} D_{bq} D_{cq} D_{dq} D_{eq} D_{fq})^{1/s}}{D_{3q}}$ approaches unity as the finite point "q" approaches infinity. This means that as "q" moves farther away from the conductor, the flux linkages of strand "a" simplify to

$$\psi_a = 2 \times 10^{-7} I_4 \log_e \frac{D_{a3}}{(r'_a D_{ab} D_{ac} D_{ad} D_{ae} D_{af})^{1/s}} \quad \text{weber-turns.} \quad (3-15)$$

The inductance of strand "a" is obtained by substituting equation (3-15) into equation (3-1). The inductance of strand "a" is given as

$$L_a = \frac{\psi_a}{I_4} = 2 \times 10^{-7} s \log_e \frac{D_{a3}}{(r'_a D_{ab} D_{ac} D_{ad} D_{ae} D_{af})^{1/s}} \quad \text{henrys/meter.} \quad (3-16)$$

Equation (3-16) represents the inductance of only strand "a". There are "s" number of strands which comprise the concentric neutral. Therefore, the average inductance of "s" strands must be calculated in order to derive an expression for the total inductance of conductor 4. The

average inductance of a stranded conductor consisting of "s" strands is

$$L_{ave} = \frac{L_a + L_b + L_c + L_d + L_e + L_f}{s} \quad (3-17)$$

Since there are "s" strands which are geometrically symmetric and identical in construction, the inductance of each strand is equal. Equation (3-17) can then be simplified to

$$L_{ave} = \frac{sL_a}{s} = L_a \quad (3-18)$$

The total inductance of conductor 4 is calculated using the relationship

$$L_4 = \frac{L_{ave}}{s} = \frac{L_a}{s} \quad (3-19)$$

Substituting the expression for L_a into equation (3-19) and simplifying, yields

$$L_4 = 2 \times 10^{-7} \log_e \frac{D_{a3}}{(r'_a D_{ab} D_{ac} D_{ad} D_{ae} D_{af})^{1/6}} \quad \text{henrys/meter,} \quad (3-20)$$

which is the inductance of conductor 4.

The inductive reactance of conductor 4 can be derived by substituting equation (3-20) into equation (3-9) and simplifying. The resulting equation for the inductive reactance of conductor 4 is

$$X_{L4} = 4\pi f \times 10^{-7} \log_e \frac{D_{a3}}{(r'_a D_{ab} D_{ac} D_{ad} D_{ae} D_{af})^{1/6}} \quad \text{ohms/meter.} \quad (3-21)$$

The total inductance and total reactance of the circuit can be derived by adding the two inductance terms given in equations (3-8) and (3-20) and substituting the result in equation (3-9). The total circuit inductance and the total inductive reactance are given as

$$L_{\text{TOTAL}} = 2 \times 10^{-7} \log_e \frac{(D_{3a}D_{3b}D_{3c}D_{3d}D_{3e}D_{3f})^{1/s} (D_{a3})}{(r_3')(r_a'D_{ab}D_{ac}D_{ad}D_{ae}D_{af})^{1/s}}$$

henrys/meter

(3-22)

and

$$X_{L\text{-TOTAL}} = 4\pi f \times 10^{-7} \log_e \frac{(D_{3a}D_{3b}D_{3c}D_{3d}D_{3e}D_{3f})^{1/s} (D_{a3})}{(r_3')(r_a'D_{ab}D_{ac}D_{ad}D_{ae}D_{af})^{1/s}}$$

ohms/meter.

(3-23)

The inductance and inductive reactance formulas, which have been derived thus far, hold true only if the overhead circuit and the underground circuit are considered individually. The equations which follow pertain to the situation where the overhead and the underground circuits are physically parallel, but only the neutrals of each are electrically parallel. For simplification purposes, it is assumed that one span of overhead cable is equal to one span of underground cable. The same assumptions used previously apply in this case. These assumptions are: (1) the current density in each conductor is constant, and (2) the total current in the phase conductor returns in the paralleled neutrals. The methods required to derive the new expressions are exactly the same as

the previous derivations. Figure (3-3) illustrates the configuration to be analyzed. As before, the distance between each conductor, or strand, is designated by a "D", with subscripts indicating the conductor or strands in question.

Illustrated in figure (3-3) are the distances to be considered when deriving an expression for the inductance of conductor 1 or conductor 2. Initially, the flux linkages of conductor 1 can be written as

Flux linkages of conductor 1 = Internal flux linkages of conductor 1 due to the current in conductor 1 + external flux linkages of conductor 1 due to the current in conductor 1 + external flux linkages of conductor 1 due to the current in conductor 2 + external flux linkages of conductor 1 due to the current in conductor 3 + external flux linkages of conductor 1 due to the current in strand "a" + external flux linkages of conductor 1 due to the current in strand "b" + external flux linkages of conductor 1 due to the current in strand "c" + external flux linkages of conductor 1 due to the current in strand "d" + external flux linkages of conductor 1 due to the current in strand "e" + external flux linkages of conductor 1 due to the current in strand "f".

The point "q" is not shown in figure (3-3) but is assumed to be located at a finite distance in space. Therefore, the expression for the flux linkages of conductor 1 can be written as

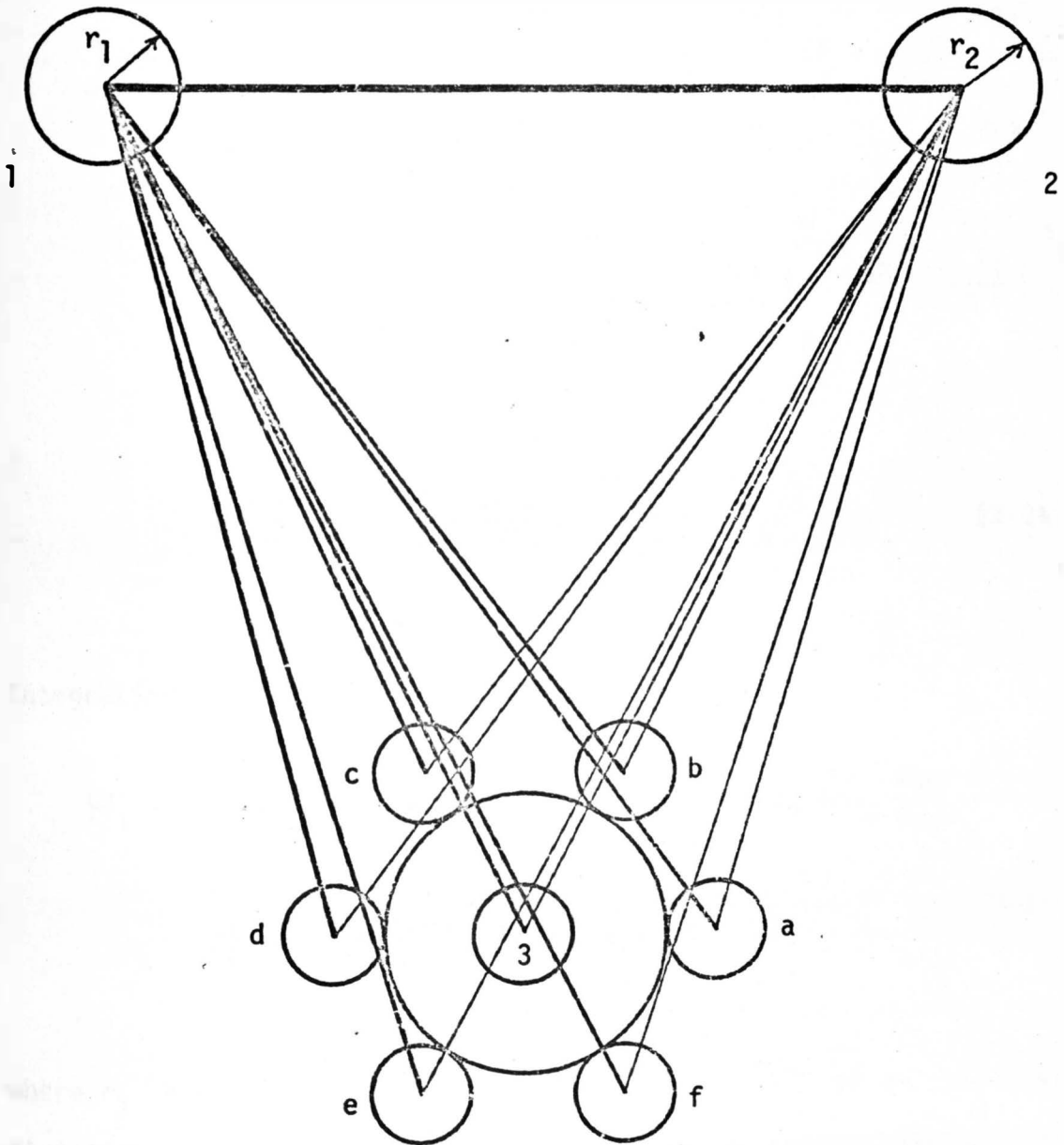

Figure (3-3)

GEOMETRIC DISTANCES USED TO DETERMINE THE
INDUCTANCES OF CONDUCTOR 1 AND CONDUCTOR 2 OF A
PARALLELED OVERHEAD-UNDERGROUND SYSTEM

$$\begin{aligned}
\int d\psi_1 = & \frac{I_1}{2} \times 10^{-7} + \frac{\mu I_1}{2\pi} \int_{r_1}^{D_{1q}} \frac{dx}{x} - \frac{\mu I_2}{2\pi} \int_{D_{12}}^{D_{2q}} \frac{dx}{x} + \frac{\mu I_3}{2\pi} \int_{D_{13}}^{D_{3q}} \frac{dx}{x} \\
& - \frac{\mu I_4}{2\pi s} \int_{D_{1a}}^{D_{aq}} \frac{dx}{x} - \frac{\mu I_4}{2\pi s} \int_{D_{1b}}^{D_{bq}} \frac{dx}{x} - \frac{\mu I_4}{2\pi s} \int_{D_{1c}}^{D_{cq}} \frac{dx}{x} - \frac{\mu I_4}{2\pi s} \int_{D_{1d}}^{D_{dq}} \frac{dx}{x} \\
& - \frac{\mu I_4}{2\pi s} \int_{D_{1e}}^{D_{eq}} \frac{dx}{x} - \frac{\mu I_4}{2\pi s} \int_{D_{1f}}^{D_{fq}} \frac{dx}{x}. \tag{3-24}
\end{aligned}$$

Integrating and combining like terms yields

$$\begin{aligned}
\psi_1 = & 2 \times 10^{-7} \left(I_1 \log_e \frac{D_{1q}}{r_1'} - I_2 \log_e \frac{D_{2q}}{D_{12}} + I_3 \log_e \frac{D_{3q}}{D_{13}} \right. \\
& \left. - \frac{I_4}{s} \log_e \frac{D_{aq} D_{bq} D_{cq} D_{dq} D_{eq} D_{fq}}{D_{1a} D_{1b} D_{1c} D_{1d} D_{1e} D_{1f}} \right) \tag{3-25}
\end{aligned}$$

where $r_1' = r_1 e^{-\frac{1}{4}}$. The algebraic signs are a result of the relative direction of the flux linkages. Equation (3-25) can be rewritten as

$$\begin{aligned}
\psi_1 = & 2 \times 10^{-7} \left[I_1 \log_e \frac{1}{r_1'} + I_1 \log_e (D_{1q}) - I_2 \log_e \frac{1}{D_{12}} \right. \\
& - I_2 \log_e (D_{2q}) + I_3 \log_e \frac{1}{D_{13}} + I_3 \log_e (D_{3q}) \\
& \left. - I_4 \log_e \frac{1}{(D_{1a} D_{1b} D_{1c} D_{1d} D_{1e} D_{1f})^{1/s}} - I_4 \log_e (D_{aq} D_{bq} D_{cq} D_{dq} D_{eq} D_{fq})^{1/s} \right]. \tag{3-26}
\end{aligned}$$

As the point "q" moves farther away from the conductors and approaches infinity, the distances D_{1q} , D_{2q} , D_{3q} , D_{aq} , D_{bq} , D_{cq} , D_{dq} , D_{eq} , and D_{fq} can be assumed to be approximately equal. Therefore, the terms pertaining to point "q" in equation (3-26) can be written as

$$I_1 \log_e (D_{1q}) - I_2 \log_e (D_{1q}) + I_3 \log_e (D_{1q}) - I_4 \log_e (D_{1q}). \quad (3-27)$$

Since $I_1 + I_3 = I_2 + I_4$, equation (3-27) can be rewritten in terms of the logarithm of a quotient. The resulting quotient is

$$(I_1 + I_3) \log_e \frac{D_{1q}}{D_{1q}}, \quad (3-28)$$

which is equal to zero, since the $\log_e 1 = 0$. As a result, equation (3-26) simplifies to

$$\begin{aligned} \psi_1 = & 2 \times 10^{-7} \left[I_1 \log_e \frac{1}{r_1'} - I_2 \log_e \frac{1}{D_{12}} + I_3 \log_e \frac{1}{D_{13}} \right. \\ & \left. - I_4 \log_e \frac{1}{(D_{1a}D_{1b}D_{1c}D_{1d}D_{1e}D_{1f})^{1/6}} \right] \quad \text{weber-turns.} \quad (3-29) \end{aligned}$$

Substituting equation (3-29) into equation (3-1) and simplifying, yields

$$\begin{aligned} L_1 = & \frac{2 \times 10^{-7}}{I_1} \left[I_1 \log_e \frac{1}{r_1'} - I_2 \log_e \frac{1}{D_{12}} + I_3 \log_e \frac{1}{D_{13}} \right. \\ & \left. - I_4 \log_e \frac{1}{(D_{1a}D_{1b}D_{1c}D_{1d}D_{1e}D_{1f})^{1/6}} \right] \quad \text{henrys/meter.} \quad (3-30) \end{aligned}$$

The inductive reactance of conductor 1 can be derived by once again utilizing equation (3-9). Substituting equation (3-30) into equation (3-9) and simplifying, yields

$$X_{L1} = \frac{4\pi f}{I_1} \times 10^{-7} \left(I_1 \log_e \frac{1}{r_1'} - I_2 \log_e \frac{1}{D_{12}} + I_3 \log_e \frac{1}{D_{13}} - I_4 \log_e \frac{1}{(D_{1a}D_{1b}D_{1c}D_{1d}D_{1e}D_{1f})^{1/5}} \right) \quad \text{ohms/meter,} \quad (3-31)$$

which is the inductive reactance of conductor 1.

The inductance of conductor 2 is derived in exactly the same manner as is conductor 1. In order to avoid repetition, the formal derivation for the inductance of conductor 2 will not be given. However, the final formulas for the inductance and for the inductive reactance will be given below. They are

$$L_2 = \frac{2 \times 10^{-7}}{I_2} \left(-I_1 \log_e \frac{1}{D_{21}} + I_2 \log_e \frac{1}{r_2'} - I_3 \log_e \frac{1}{D_{23}} + I_4 \log_e \frac{1}{(D_{2a}D_{2b}D_{2c}D_{2d}D_{2e}D_{2f})^{1/5}} \right) \quad \text{henrys/meter} \quad (3-32)$$

and

$$X_{L2} = \frac{4\pi f}{I_2} \times 10^{-7} \left(-I_1 \log_e \frac{1}{D_{21}} + I_2 \log_e \frac{1}{r_2'} - I_3 \log_e \frac{1}{D_{23}} + I_4 \log_e \frac{1}{(D_{2a}D_{2b}D_{2c}D_{2d}D_{2e}D_{2f})^{1/5}} \right) \quad \text{ohms/meter.} \quad (3-33)$$

Due to the presence of the overhead circuit, the inductance of the underground phase conductor is modified. This alteration is taken into account by including the flux linkages due to the currents in conductor 1 and conductor 2. The new expression for the flux linkages of conductor 3 becomes

Total flux linkages = Internal flux linkages of conductor 3 due to the current in conductor 3 + external flux linkages of conductor 3 due to the current in conductor 3 + external flux linkages of conductor 3 due to the current in conductor 1 + external flux linkages of conductor 3 due to the current in conductor 2 + external flux linkages of conductor 3 due to the current in each of the strands of conductor 4.

Figure (3-4) illustrates the distances which describe the limits of integration used in determining the flux linkages of conductor 3. The point "q" is not shown in figure (3-4), but is assumed to be a finite point in space. Analytically, the total flux linkages of conductor 3 can be expressed as

$$\int d\psi_3 = \frac{I_3}{2} \times 10^{-7} + \frac{\mu I_3}{2\pi} \int_{r_3}^{D_{3q}} \frac{dx}{x} + \frac{\mu I_1}{2\pi} \int_{D_{13}}^{D_{1q}} \frac{dx}{x} - \frac{\mu I_2}{2\pi} \int_{D_{23}}^{D_{2q}} \frac{dx}{x}$$

$$- \frac{\mu I_4}{2\pi s} \int_{D_{3a}}^{D_{aq}} \frac{dx}{x} - \frac{\mu I_4}{2\pi s} \int_{D_{3b}}^{D_{bq}} \frac{dx}{x} - \frac{\mu I_4}{2\pi s} \int_{D_{3c}}^{D_{cq}} \frac{dx}{x}$$

$$- \frac{\mu I_4}{2\pi s} \int_{D_{3d}}^{D_{dq}} \frac{dx}{x} - \frac{\mu I_4}{2\pi s} \int_{D_{3e}}^{D_{eq}} \frac{dx}{x} - \frac{\mu I_4}{2\pi s} \int_{D_{3f}}^{D_{fq}} \frac{dx}{x}.$$

(3-34)

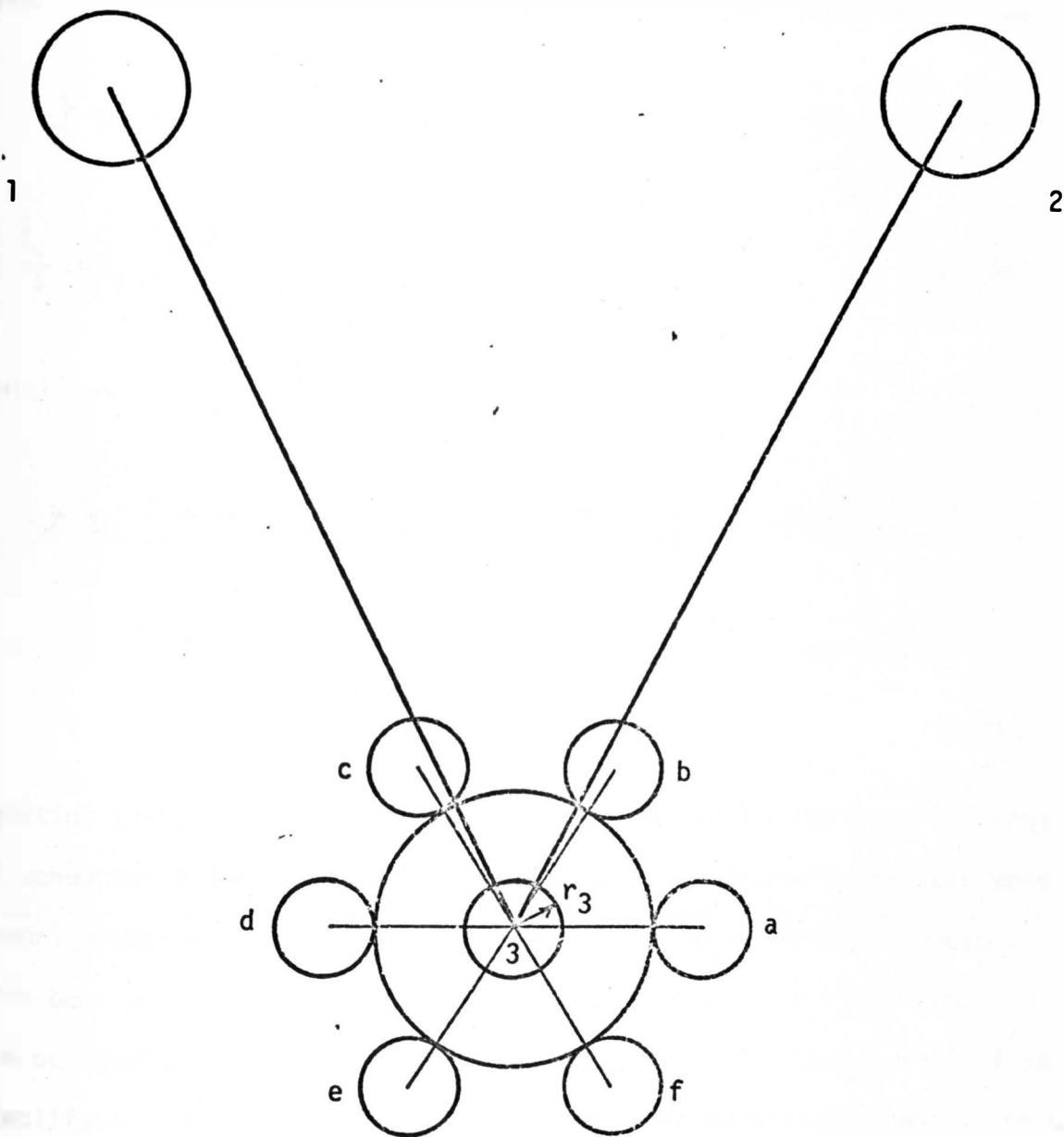

Figure (3-4)

GEOMETRIC DISTANCES USED TO DETERMINE THE INDUCTANCE
OF CONDUCTOR 3 OF A PARALLELED OVERHEAD-UNDERGROUND SYSTEM

After integrating and combining common terms, equation (3-34) becomes

$$\begin{aligned} \psi_3 = & 2 \times 10^{-7} \left(I_1 \log_e \frac{D_{1q}}{D_{13}} - I_2 \log_e \frac{D_{2q}}{D_{23}} + I_3 \log_e \frac{D_{3q}}{r_3'} \right. \\ & \left. - \frac{I_4}{s} \log_e \frac{D_{aq} D_{bq} D_{cq} D_{dq} D_{eq} D_{fq}}{D_{3a} D_{3b} D_{3c} D_{3d} D_{3e} D_{3f}} \right) \end{aligned} \quad (3-35)$$

which, as before, can be simplified to

$$\begin{aligned} \psi_3 = & 2 \times 10^{-7} \left(I_1 \log_e \frac{1}{D_{13}} - I_2 \log_e \frac{1}{D_{23}} + I_3 \log_e \frac{1}{r_3'} \right. \\ & \left. - I_4 \log_e \frac{1}{(D_{3a} D_{3b} D_{3c} D_{3d} D_{3e} D_{3f})^{1/s}} \right) \quad \text{weber-turns.} \end{aligned} \quad (3-36)$$

Equation (3-36) is the final expression representing the flux linkages of conductor 3 due to all of the currents in the other conductors which comprise the parallel combination. Now that the total flux linkages have been determined, an expression for the inductance of conductor 3 can be developed. Substituting equation (3-36) into equation (3-1) and simplifying, results in an equation for the inductance of a solid conductor. This expression is

$$\begin{aligned} L_3 = & \frac{2 \times 10^{-7}}{I_3} \left(I_1 \log_e \frac{1}{D_{13}} - I_2 \log_e \frac{1}{D_{23}} + I_3 \log_e \frac{1}{r_3'} \right. \\ & \left. - I_4 \log_e \frac{1}{(D_{3a} D_{3b} D_{3c} D_{3d} D_{3e} D_{3f})} \right) \quad \text{henrys/meter.} \end{aligned} \quad (3-37)$$

The inductive reactance of conductor 3 can be obtained by substituting equation (3-37) into equation (3-9). After simplifying, the expression becomes

$$X_{L3} = \frac{4\pi f \times 10^{-7}}{I_3} \left(I_1 \log_e \frac{1}{D_{13}} - I_2 \log_e \frac{1}{D_{23}} + I_3 \log_e \frac{1}{r_3} - I_4 \log_e \frac{1}{(D_{3a}D_{3b}D_{3c}D_{3d}D_{3e}D_{3f})^{1/s}} \right) \quad \text{ohms/meter.} \quad (3-38)$$

Finally, the last of the four inductances to be considered is the neutral return path consisting of "s" identical strands. Figure (3-5) illustrates the distances to be considered in determining the total flux linkages of strand "a". Again, the assumption is made that a point "q" exists at a finite distance in space. The flux linkages of strand "a" include

Total flux linkages = Internal flux linkages of strand "a" due to the current in strand "a" + external flux linkages of strand "a" due to the current in strand "a" + external flux linkages of strand "a" due to the currents in strands "b", "c", "d", "e", and "f" + external flux linkages of strand "a" due to the current in conductor 3 + external flux linkages of strand "a" due to the current in conductor 1 + external flux linkages of strand "a" due to the current in conductor 2,

which can be expressed analytically as

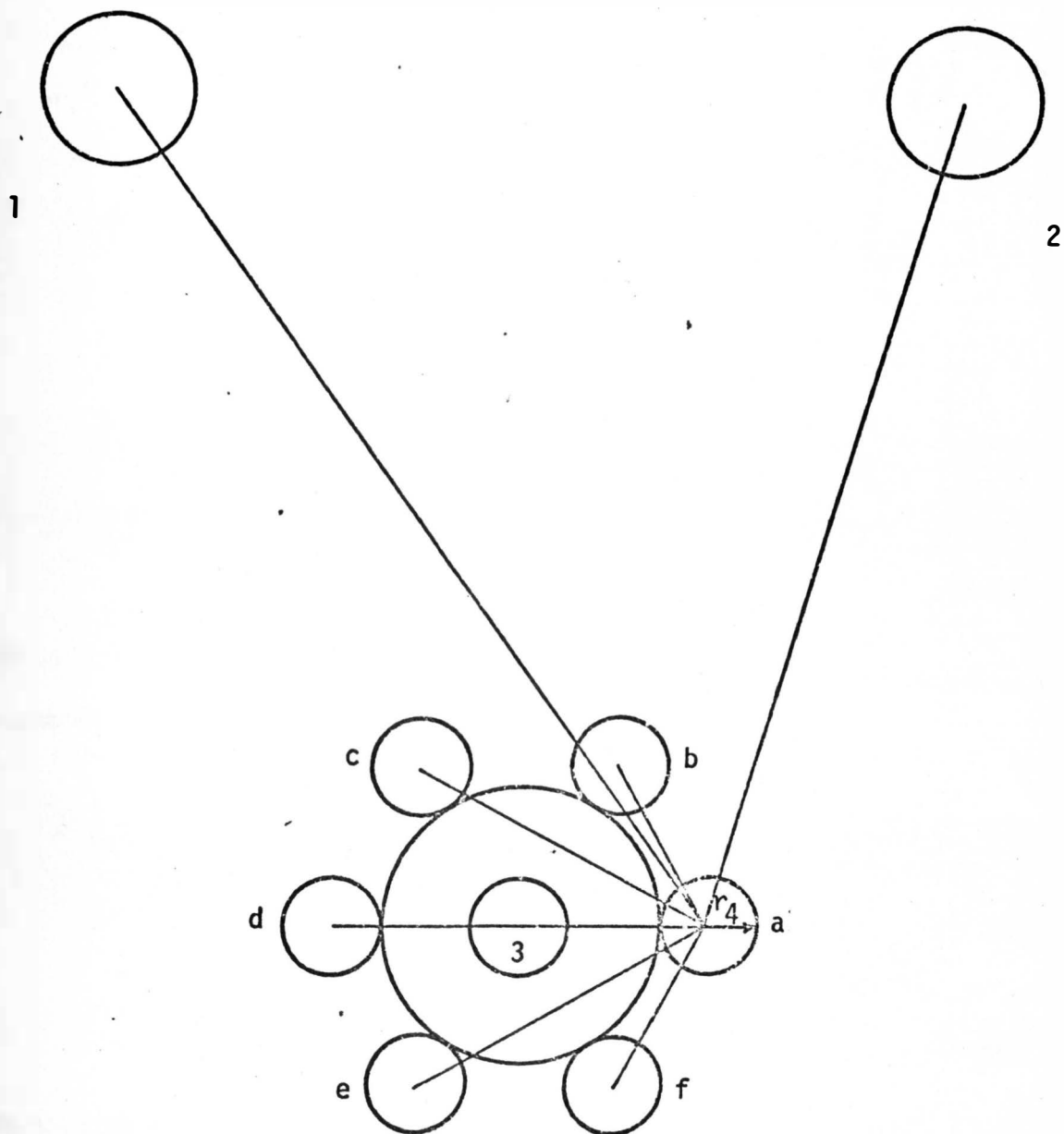

Figure (3-5)

GEOMETRIC DISTANCES USED TO DETERMINE THE INDUCTANCE
OF STRAND "a" OF A PARALLELED OVERHEAD-UNDERGROUND SYSTEM

$$\begin{aligned}
\int d\psi_a = & \frac{I_4}{2s} \times 10^{-7} + \frac{\mu I_4}{2\pi s} \int_{r_a}^{D_{aq}} \frac{dx}{x} + \frac{\mu I_4}{2\pi s} \int_{D_{ab}}^{D_{bq}} \frac{dx}{x} + \frac{\mu I_4}{2\pi s} \int_{D_{ac}}^{D_{cq}} \frac{dx}{x} \\
& + \frac{\mu I_4}{2\pi s} \int_{D_{ad}}^{D_{dq}} \frac{dx}{x} + \frac{\mu I_4}{2\pi s} \int_{D_{ae}}^{D_{eq}} \frac{dx}{x} + \frac{\mu I_4}{2\pi s} \int_{D_{af}}^{D_{fq}} \frac{dx}{x} \\
& - \frac{\mu I_3}{2\pi} \int_{D_{a3}}^{D_{3q}} \frac{dx}{x} + \frac{\mu I_2}{2\pi} \int_{D_{a2}}^{D_{2q}} \frac{dx}{x} - \frac{\mu I_1}{2\pi} \int_{D_{a1}}^{D_{1q}} \frac{dx}{x} .
\end{aligned}
\tag{3-39}$$

After eliminating the terms pertaining to point "q", as was previously accomplished, and simplifying, equation (3-39) becomes

$$\begin{aligned}
\psi_a = & 2 \times 10^{-7} \left[-I_1 \log_e \frac{1}{D_{a1}} + I_2 \log_e \frac{1}{D_{a2}} - I_3 \log_e \frac{1}{D_{a3}} \right. \\
& \left. + I_4 \log_e \frac{1}{(r_a' D_{ab} D_{ac} D_{ad} D_{ae} D_{af})^{1/s}} \right] \quad \text{weber-turns.}
\end{aligned}
\tag{3-40}$$

Again, utilizing equation (3-1), the inductance of strand "a" can be written as

$$\begin{aligned}
L_a = & \frac{2 \times 10^{-7}}{I_4} s \left[-I_1 \log_e \frac{1}{D_{a1}} + I_2 \log_e \frac{1}{D_{a2}} - I_3 \log_e \frac{1}{D_{a3}} \right. \\
& \left. + I_4 \log_e \frac{1}{(r_a' D_{ab} D_{ac} D_{ad} D_{ae} D_{af})^{1/s}} \right] \quad \text{henrys/meter.}
\end{aligned}
\tag{3-41}$$

The total inductance of conductor 4 can be derived by first applying equation (3-17), and then equation (3-18). In this particular case, due to symmetry, the inductance of each strand can be assumed to be equal. This will not introduce an appreciable error. Therefore, the average inductance is equal to the inductance of any one of the "s" strands. The total inductance of conductor 4, made up of "s" strands, is then given as

$$L_4 = \frac{2 \times 10^{-7}}{I_4} \left(-I_1 \log_e \frac{1}{D_{a1}} + I_2 \log_e \frac{1}{D_{a2}} - I_3 \log_e \frac{1}{D_{a3}} \right. \\ \left. + I_4 \log_e \frac{1}{(r_a' D_{ab} D_{ac} D_{ad} D_{ae} D_{af})^{1/s}} \right) \text{ henrys/meter.} \quad (3-42)$$

Substituting equation (3-42) into equation (3-9) and simplifying, results in an expression for the inductive reactance of conductor 4.

This expression is

$$X_{L4} = \frac{4\pi f}{I_4} \times 10^{-7} \left(-I_1 \log_e \frac{1}{D_{a1}} + I_2 \log_e \frac{1}{D_{a2}} - I_3 \log_e \frac{1}{D_{a3}} \right. \\ \left. + I_4 \log_e \frac{1}{(r_a' D_{ab} D_{ac} D_{ad} D_{ae} D_{af})^{1/s}} \right) \text{ ohms/meter.} \quad (3-43)$$

Chapter IV

DEVELOPMENT OF THE CAPACITANCE FORMULAS FOR AN UNDERGROUND
CIRCUIT ALONE AND AN OVERHEAD-UNDERGROUND PARALLEL CIRCUIT

The capacitance between two conductors is defined as the charge per unit of potential difference between the two conductors. The unit of charge, Q , which is the coulomb, is equal to 1 ampere-second and will repel a like charge at a distance of one meter with a force of 9×10^9 joules.¹⁸ The potential difference between two points is equal to the work necessary to move a coulomb of charge between two points.¹⁷ This potential difference can be described in terms of the electric field between these two oppositely charged conductors.

Capacitance, unlike inductance, is described by the electric field. The distinct difference between the electric field and the magnetic field is that the electric field originates at a point of positive charge and terminates at a point of opposite charge. The lines of electric flux which emanate from the positively charged conductor are numerically equal to the total charge on the conductor.¹⁷ Since the conductors of a power line are primarily isolated, and the charge will be assumed to be uniformly distributed on the surface of the conductor, the lines of flux describing the electric field will be directed radially outward. For this ideal case, points located at equal distances on these lines of flux have the same potential and the same electric flux density. The electric flux density, D , is defined as the charge per unit area. For a conductor, this is given as

$$D = \frac{Q}{2\pi x} \quad \text{coulombs/meter}^2, \quad (4-1)$$

where Q is the charge on the conductor in coulombs per meter and x is the radius in meters of the area being calculated. The electric field intensity is equal to the electric flux density divided by the permittivity, k . This is given as

$$\mathcal{E} = \frac{D}{k} = \frac{Q}{2\pi kx} \quad \text{volts/meter.} \quad (4-2)$$

The permittivity, k , is defined as $k = k_r k_0$, where k_0 is the permittivity of free space and k_r is the relative permittivity or the dielectric constant of the insulating medium.¹⁷ The electric field intensity is a force per unit charge which, when integrated between two points, results in an expression representing the work done in moving a charge from one point to another. This work is independent of the path taken. Therefore, the potential difference between two points can be expressed as

$$V_{12} = \int_{D_1}^{D_2} \frac{D}{\mathcal{E}} dx \quad \text{volts.} \quad (4-3)$$

The capacitance between two parallel conductors of a single-phase system, separated by a distance " D ", can be developed using equation (4-3), figure (4-1), and

$$C = \frac{Q}{V} \quad \text{farads/meter.} \quad (4-4)$$

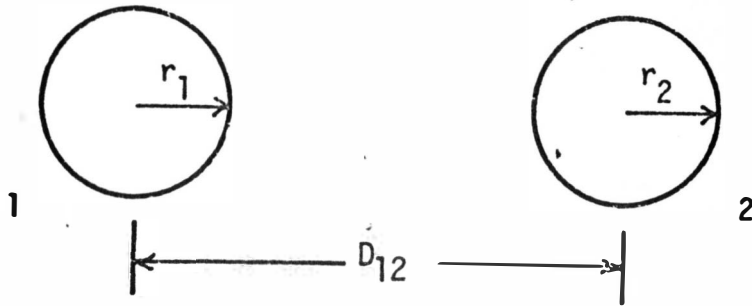

Figure (4-1)

CROSS SECTION OF TWO PARALLEL CONDUCTORS

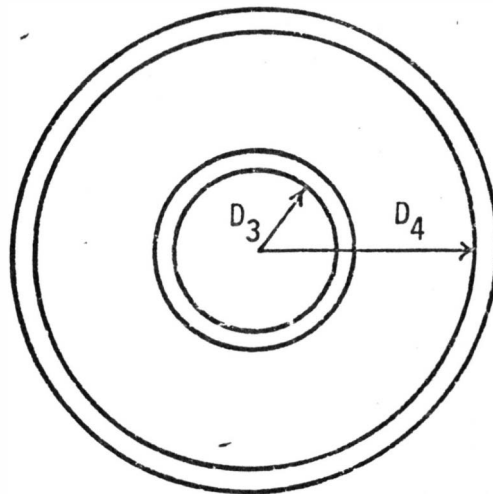

Figure (4-2)

CROSS SECTION OF AN UNDERGROUND CABLE

$$V_{12} = \int_{r_1}^{D_{12}} \frac{Q_1}{2\pi kx} dx + \int_{D_{12}}^{r_2} \frac{Q_2}{2\pi kx} dx \quad (4-5)$$

which, when integrated, becomes

$$V_{12} = \frac{Q_1}{2\pi k} \log_e \frac{D_{12}}{r_1} + \frac{Q_2}{2\pi k} \log_e \frac{r_2}{D_{12}}. \quad (4-6)$$

For a closed system, the sum of the charges Q_1 and Q_2 must equal zero.

Therefore, if no other charges exist in the vicinity, $Q_1 = -Q_2$ and V_{12}

becomes

$$V_{12} = \frac{Q_1}{2\pi k} \log_e \frac{D_{12}^2}{r_1 r_2} \quad \text{volts.} \quad (4-7)$$

The capacitance can then be derived by substituting equation (4-7) into equation (4-4) to yield

$$C_{12} = \frac{2\pi k}{\log_e \frac{D_{12}^2}{r_1 r_2}} \quad \text{farads/meter.} \quad (4-8)$$

It is evident from this expression that the magnitude of the capacitance is dependent on the spacing of the conductors, the radius of the conductors, and the relative permittivity of the medium.

An underground concentric neutral cable is very similar to the single-phase circuit just described. The cable consists of a phase conductor and a concentrically wound neutral return path. A solid insulation separates the phase conductor from the neutral conductor. A

capacitance is created between the phase conductor and the neutral return when the cable is energized. The sinusoidal voltage impressed on the newly formed capacitor causes a current through the capacitor. This current, which is called a charging current, is dependent on the rate of change of the voltage and the magnitude of the capacitance.¹⁹ The magnitude of the capacitance is dependent on the spacing between the two conductors, the physical size of the conductors, and the magnitude of the dielectric constant.

Since a cable is a capacitor, lines of flux radiate outward from the center conductor. These lines of flux, which are assumed to be uniformly distributed, penetrate the insulation and seek a point of opposite charge.²⁰ In order to contain the electric field, a grounded semiconducting shield is provided. This shield is extruded around the insulation surface and provides an intimate contact with the insulation. Close contact of the shield with the insulation helps to prevent corona, which can initiate cable deterioration.²¹ Since the semiconducting shield is grounded and uniformly distributed around the insulation, the radiating electric field terminates at the outer edge of the insulation surface. This means that the charge is uniformly distributed over the outer surface of the insulation. Another conducting shield is extruded around the conductor. This shield also aids in the prevention of corona and helps to uniformly distribute the charge around the inside of the insulation surface. The various components discussed above are shown in figure (3-1) of Chapter III. Since the electric field is contained within the insulation, the capacitance of the cable is directly affected by the thickness of the insulation.

Figure (4-2) is a simplified cross section of an underground cable. The potential difference between the outer edge of the conductor and the outer edge of the insulation is given as

$$V_{34} = \int_{D_3}^{D_4} \mathcal{E} \, dx = \int_{D_3}^{D_4} \frac{Q}{2\pi kx} \, dx \quad \text{volts.} \quad (4-9)$$

Integrating equation (4-9) results in

$$V_{34} = \frac{Q}{2\pi k} \log_e \frac{D_4}{D_3} \quad \text{volts.} \quad (4-10)$$

Substituting equation (4-10) into equation (4-4) and simplifying, yields

$$C = \frac{2\pi k}{\log_e \frac{D_4}{D_3}} \quad \text{farads/meter,} \quad (4-11)$$

which is the capacitance between the phase conductor and the grounded shield. The permittivity of free space, k_0 , is 8.85×10^{-12} farads/meter, which, when converted to farads/1000 feet, becomes 2.71×10^{-9} farads/1000 feet. Substituting this new value for k_0 into equation (4-11), and changing the natural logarithm to a base 10 logarithm, results in a new expression for the capacitance. This expression is

$$C = \frac{0.00736 \, k_r}{\log_{10} \frac{D_4}{D_3}} \quad \mu \text{ farads/1000 feet} \quad (4-12)$$

where k_r is the dielectric constant of the insulation. This equation is the same equation which is given in the Rome Cable URD Technical Manual.²¹

Figure (4-3) represents a parallel overhead single-phase circuit and an underground single-phase circuit. The neutral conductors of these two circuits are electrically connected in parallel. If the current in conductor 3 is assumed to be equal to zero, the remaining circuit consists of the overhead phase conductor and the two paralleled neutral conductors. Since the neutrals of the two circuits are connected, current will exist in both of the conductors. Because there is current, a charge will exist which is probably not equal in magnitude. However, since there is a charge on each of the return conductors, a capacitance will be formed between the phase conductor and each of the two return paths. Again, it is assumed that all of the current in conductor 1 returns in conductor 2 and conductor 4. This means that there is not a return current path in the earth.

The potential between conductor 1 and conductor 2, due to charges Q_1 , Q_2 , and Q_4 , can be written as

$$V_{12} = \frac{Q_1}{2\pi k} \int_{r_1}^{D_{12}} \frac{dx}{x} + \frac{Q_2}{2\pi k} \int_{D_{12}}^{r_2} \frac{dx}{x} + \frac{Q_4}{2\pi k} \int_{D_{14}}^{D_{24}} \frac{dx}{x} \quad (4-13)$$

where r_1 and r_2 are the radii of conductor 1 and conductor 2, respectively. Integrating equation (4-13) yields

$$V_{14} = \frac{Q_1}{2\pi k} \log_e \frac{D_{12}}{r_1} + \frac{Q_2}{2\pi k} \log_e \frac{r_2}{D_{12}} + \frac{Q_4}{2\pi k} \log_e \frac{D_{24}}{D_{14}} \quad \text{volts.} \quad (4-14)$$

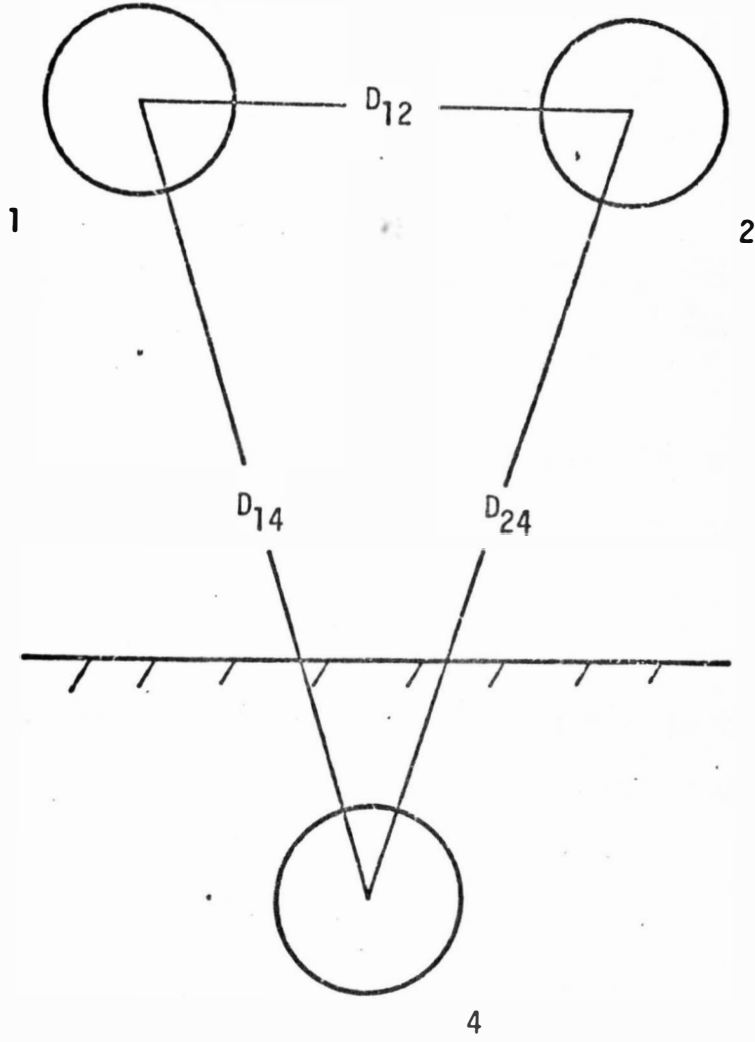

Figure (4-3)

CROSS SECTION OF A PARALLELED OVERHEAD-UNDERGROUND SYSTEM

The potential between conductor 1 and conductor 4, due to charges Q_1 , Q_2 , and Q_4 , can be given as

$$V_{14} = \frac{Q_1}{2\pi k} \int_{r_1}^{D_{14}} \frac{dx}{x} + \frac{Q_4}{2\pi k} \int_{D_{14}}^{r_4} \frac{dx}{x} + \frac{Q_2}{2\pi k} \int_{D_{12}}^{D_{24}} \frac{dx}{x}, \quad (4-15)$$

which can be integrated and rewritten as

$$V_{14} = \frac{Q_1}{2\pi k} \log_e \frac{D_{14}}{r_1} + \frac{Q_4}{2\pi k} \log_e \frac{r_4}{D_{14}} + \frac{Q_2}{2\pi k} \log_e \frac{D_{24}}{D_{12}} \quad \text{volts.} \quad (4-16)$$

Equation (4-14) and equation (4-5) both express the potential between two conductors in terms of charges and geometric distances. In order to calculate the capacitance between these conductors, charge Q_2 and charge Q_4 must be expressed in terms of charge Q_1 . For a closed system with no other influencing charge existing external to the three conductors, the sum of the charges in the system must equal zero. This means that

$$Q_1 + Q_2 + Q_4 = 0. \quad (4-17)$$

Normally, if only conductors 1 and 2 were being considered, the charge Q_2 would be equal in magnitude and opposite in sign from that of Q_1 . In this case, this is not true, since the return current splits between the two neutral conductors. The amount of charge on Q_2 can be expressed as a fraction of Q_1 by

$$Q_2 = K_1 Q_1 \quad (4-18)$$

where K_1 is a fraction to be determined. The charge Q_4 can be similarly expressed by

$$Q_4 = K_2 Q_1 \quad (4-19)$$

where K_2 is again a fraction to be determined. One more equation can be derived by substituting the fractional expressions for Q_2 and Q_4 into equation (4-16). The resulting equation is

$$K_1 + K_2 = -1. \quad (4-20)$$

The voltage from 1 to 2 and from 1 to 4 is equal in magnitude. Therefore, by equating equations (4-14) and (4-15) and utilizing equation (4-20), each of the fractional constants can be determined. Once these values are known, the capacitance between each of the conductors can be calculated.

The capacitance between conductor 1 and conductor 2 can now be defined in terms of the constants K_1 , K_2 , and the geometric distances. The capacitance C_{12} can be defined as

$$C_{12} = \frac{Q_1}{V_{12}} = \frac{2\pi k}{\left[\log_e \frac{D_{12}}{r_1} + K_1 \log_e \frac{r_2}{D_{12}} + K_2 \log_e \frac{D_{24}}{D_{14}} \right]} \quad \text{farads/meter.} \quad (4-21)$$

Similarly, the capacitance between conductor 1 and conductor 4 can be defined as

$$C_{14} = \frac{Q_1}{V_{14}} = \frac{2\pi k}{\left[\log_e \frac{D_{14}}{r_1} + K_1 \log_e \frac{D_{24}}{D_{12}} + K_2 \log_e \frac{r_4}{D_{14}} \right]}$$

farads/meter.

(4-22)

In both cases, the magnitude of each capacitance is dependent on the spacing of the conductors and the fraction of charge on each conductor.

Chapter V

THE DETERMINATION OF AN EQUIVALENT CIRCUIT
AND THE CALCULATION OF THE CIRCUIT PARAMETERS

A finite length of a power line can be represented by an equivalent circuit. This equivalent circuit consists of circuit parameters, which approximately describe the system. The parameters which normally are considered to be significant are: (1) resistance, (2) inductance, and (3) capacitance. In preceding chapters, expressions for the inductance and the capacitance of various circuits have been developed. In this chapter, these circuits will be modeled using the formulas that were derived. These models will be accompanied by a numerical analysis of the parameters based on data obtained from the Rome Cable URD Technical Manual.²¹ The circuits to be represented are: (1) an overhead single-phase circuit, (2) an underground single-phase circuit, and (3) an overhead single-phase circuit physically parallel with an underground circuit.

Both the overhead single-phase circuit and the underground single-phase circuit can be represented by the same equivalent circuit. The proposed model is commonly called the nominal- π equivalent circuit. This model is shown in figure (5-1), where Z represents the series impedance of the line, and Y represents the shunt admittance to neutral of the line. The series impedance is calculated by finding the sum of the total resistance and the total inductive reactance of the conductors. The shunt admittance requires the derivation of the capacitance between phase and neutral.

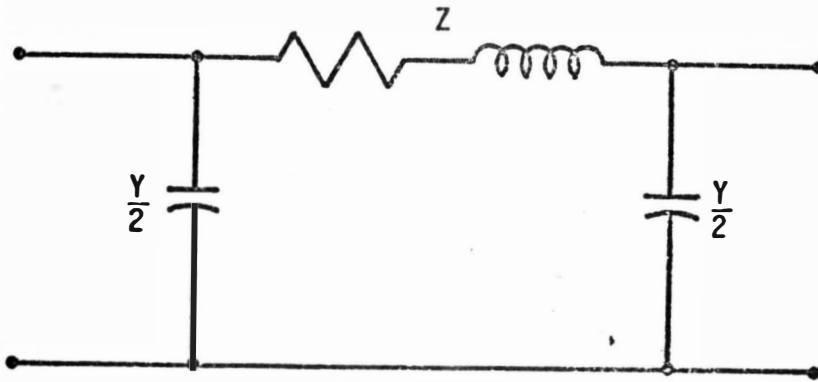

Figure (5-1)

NOMINAL- EQUIVALENT CIRCUIT

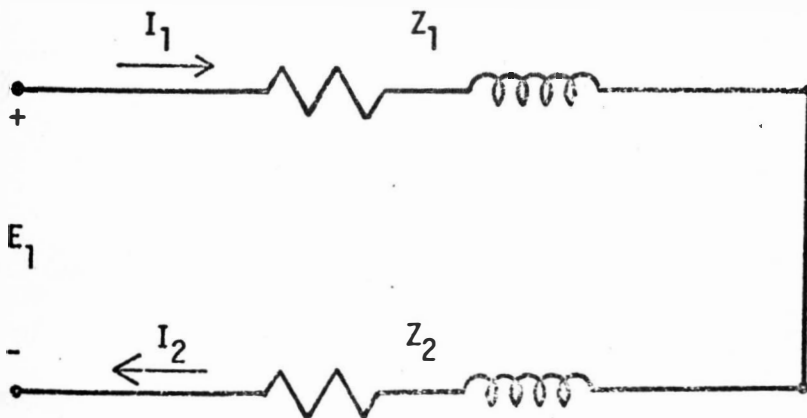

Figure (5-2)

CIRCUIT DIAGRAM FOR A SHORT-CIRCUITED
OVERHEAD SINGLE-PHASE LINE

Figure (5-2) represents a single-phase overhead circuit which has been short-circuited from phase to neutral. According to Kirchhoff's voltage law

$$E_1 = I_1 Z_1 + I_2 Z_2 \quad (5-1)$$

where Z_1 and Z_2 represent the equivalent impedances of conductors 1 and 2, respectively. The voltage drops $I_1 Z_1$ and $I_2 Z_2$ can be expressed as

$$I_1 Z_1 = I_1 R_1 + j\omega I_1 L_1 \quad (5-2)$$

and

$$I_2 Z_2 = I_2 R_2 + j\omega I_2 L_2. \quad (5-3)$$

However, since $\psi = IL$, equations (5-2) and (5-3) can be rewritten as

$$I_1 Z_1 = I_1 R_1 + j\omega \psi_1 \quad (5-4)$$

and

$$I_2 Z_2 = I_2 R_2 + j\omega \psi_2. \quad (5-5)$$

Therefore, the equations which were derived in Appendix A for the flux linkages of conductor 1 and conductor 2 can be used to determine the series impedance of the circuit, since

$$Z = \frac{E_1}{I_1} = Z_1 + Z_2 \quad (5-6)$$

and

$$I_1 = I_2. \quad (5-7)$$

The resulting expression for the series impedance of a single-phase overhead circuit is

$$Z = (R_1 + R_2) + j 2.29 \times 10^{-2} \log_e \frac{D_{12}^2}{r_1' r_2'} \quad \text{ohms/1000 feet.} \quad (5-8)$$

The resistances for all of the cases to be considered are d-c resistances corrected to 50°C. The neutral resistance of the underground conductor is corrected to 40°C.

The shunt admittance is given as

$$Y = 0.0 + j\omega C \quad (5-9)$$

where C is the capacitance between the phase conductor and neutral.

Equation (4-8) can be substituted into equation (5-9) to yield

$$Y = 0.0 + j \frac{1.7 \times 10^{-2}}{\log_e \frac{D_{12}^2}{r_1 r_2}} \quad \text{mhos/1000 feet,} \quad (5-10)$$

which is the shunt admittance for the overhead single-phase circuit.

The numerical values for this specific case can be calculated by substituting the data found in table (5-1) into equation (5-8) and equation (5-10). The series impedance for two #1/0 AWG aluminum conductors was found to be equal to $0.362 + j 0.282$ ohms/1000 feet. For two #2 AWG aluminum conductors the series impedance was found to be equal to $0.574 + j 0.294$ ohms/1000 feet. The shunt admittance between two #1/0 AWG aluminum conductors was determined to be $0.0 + j 5.4 \times 10^{-7}$ mhos/1000 feet, and between two #2 AWG aluminum conductors to be

Table (5-1)

GEOMETRIC DISTANCES FOR CALCULATION OF CIRCUIT PARAMETERS

<u>Geometric Distance</u>	<u>Distance in Feet</u>
D_{12}	5.0
$D_{13} \approx D_{1a} \approx D_{1b} \approx D_{1c} \approx D_{1d} \approx$ $D_{1e} \approx D_{1f} \approx D_{23} \approx D_{2a} \approx D_{2b} \approx$ $D_{2c} \approx D_{2d} \approx D_{2e} \approx D_{2f}$	33.1
$D_{3a} = D_{3b} = D_{3c} = D_{3d} = D_{3e} = D_{3f}$ For #1/0 AWG aluminum conductors For #2 AWG aluminum conductors	0.0393 0.0360
$D_{ab} = D_{af}$	D_{3a}
D_{ad}	$2D_{3a}$
$D_{ac} = D_{ae}$	$\sqrt{3}D_{3a}$
$r_1 = r_2 = r_3$ For #1/0 AWG aluminum conductors For #2 AWG aluminum conductors	0.0135 0.0107
r_a	0.00266

$0.0 + j 5.18 \times 10^{-7}$ mhos/1000 feet. This information, as well as other numerical values to be calculated, will be presented in table (5-2) at the end of this chapter.

The nominal- π equivalent circuit is valid for the single-phase underground circuit, as well. Figure (5-3) is a representation of the two conductors which comprise the underground circuit when it is short-circuited from phase to neutral. Kirchhoff's law can be applied to the circuit in figure (5-3) to yield

$$E_3 = I_3 Z_3 + I_4 Z_4 \quad (5-11)$$

The same procedure used to obtain the series impedance for the overhead circuit can be applied in this case. Equations (3-7) and (3-15), developed in Chapter III for the flux linkages of conductor 3 and conductor 4, can be substituted into the expressions for Z_3 and Z_4 , respectively. The resulting equation for the series impedance of an underground single-phase circuit becomes

$$Z = \left(R_3 + \frac{R_4}{s} \right) + j 2.29 \times 10^{-2} \log_e \frac{D_{3a}^2}{(r_a D_{ab} D_{ac} D_{ad} D_{ae} D_{af})^{1/s}}$$

ohms/1000 feet.

(5-12)

The numerical results for the series impedance can again be calculated using the information in table (5-1). The series impedance for a #1/0 AWG aluminum phase conductor and a #14 AWG annealed copper concentric neutral was calculated to be equal to $0.6805 + j 0.0346$ ohms/1000

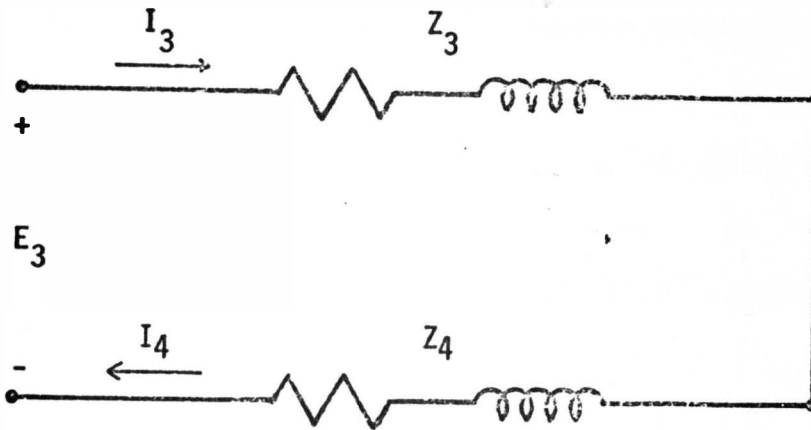

Figure (5-3)

CIRCUIT DIAGRAM FOR A SHORT-CIRCUITED
UNDERGROUND SINGLE-PHASE LINE

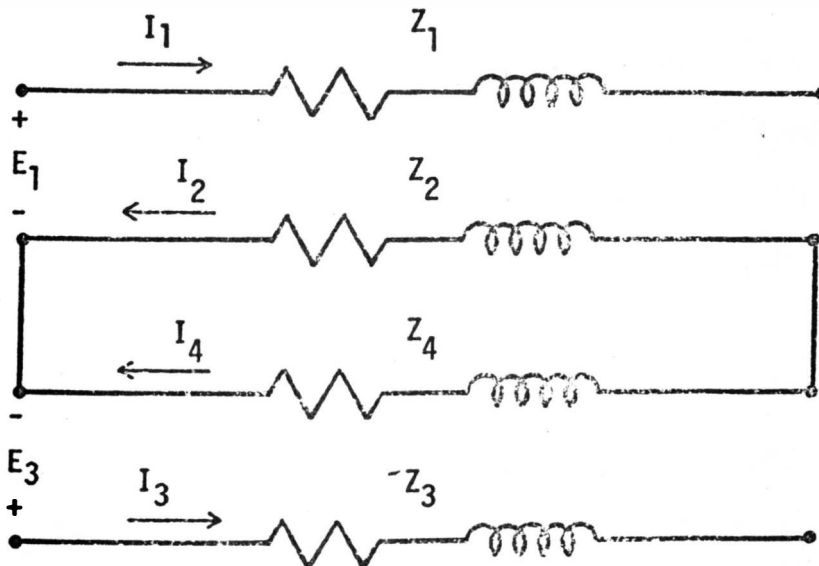

Figure (5-4)

CIRCUIT DIAGRAM FOR A PARALLELED
OVERHEAD-UNDERGROUND SINGLE-PHASE LINE

feet. The series impedance for a #2 AWG aluminum phase conductor was calculated to be equal to $0.787 + j 0.0362$ ohms/1000 feet. In both cases, the resistance of the concentric neutral was multiplied by 1.10 to allow for stranding.¹⁶

The shunt admittance can be calculated by utilizing equation (5-9) and the expression developed for the capacitance of an underground cable in Chapter IV. The expression for the shunt admittance can be written as

$$Y = 0.0 + j\omega \left[\frac{0.00736 k_r}{\log_{10} \frac{D_2}{D_1}} \right] \text{ mhos/1000 feet.} \quad (5-13)$$

where D_2 is the distance from the center of the conductor to the outside edge of the insulation, and D_1 is the distance from the center of the conductor to the inside edge of the insulation. If a #1/0 AWG aluminum phase conductor is considered, the shunt admittance can be calculated to be equal to $0.0 + j 1.6 \times 10^{-5}$ mhos/1000 feet. The shunt admittance for a #2 AWG aluminum phase conductor is equal to $0.0 + j 1.39 \times 10^{-5}$ mhos/1000 feet.

Formulas were derived in Chapter III for a single-phase overhead circuit physically parallel to a single-phase underground circuit. The neutrals of these two circuits are connected electrically in parallel. Figure (5-4) is a circuit diagram which illustrates this particular situation. Two variations of this circuit will be considered.

First, assume that the phase conductor of the overhead circuit is physically short-circuited to the neutral conductors and the current in

conductor 3 is zero. Figure (5-4) will be altered as shown in figure (5-5). It is assumed that the current in the phase conductor returns entirely in the neutral conductors and not in the earth. Therefore, a node equation representing the currents in the conductors can be written. This equation is

$$I_1 = I_2 + I_4. \quad (5-14)$$

Furthermore, utilizing Kirchhoff's voltage law, two loop equations can be written. These equations are

$$E_1 = I_1 Z_1 + I_2 Z_2 \quad (5-15)$$

and

$$-I_2 Z_2 + I_4 Z_4 = 0. \quad (5-16)$$

Since $I_3 = 0$, the equations for the flux linkages of conductor 1, conductor 2, and conductor 3 become

$$\psi_1 = 6.096 \times 10^{-5} \left[I_1 \log_e \frac{1}{r_1'} - I_2 \log_e \frac{1}{D_{12}} - I_4 \log_e \right. \quad (5-17)$$

$$\left. \frac{1}{(D_{1a} D_{1b} D_{1c} D_{1d} D_{1e} D_{1f})^{1/6}} \right],$$

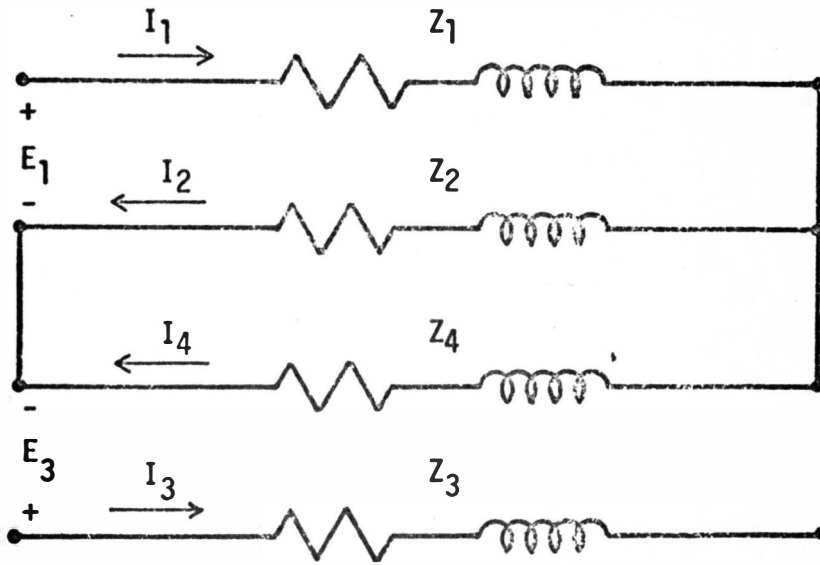

Figure (5-5)

CIRCUIT DIAGRAM FOR A PARALLELED OVERHEAD-UNDERGROUND
SINGLE-PHASE LINE WITH $I_3 = 0$

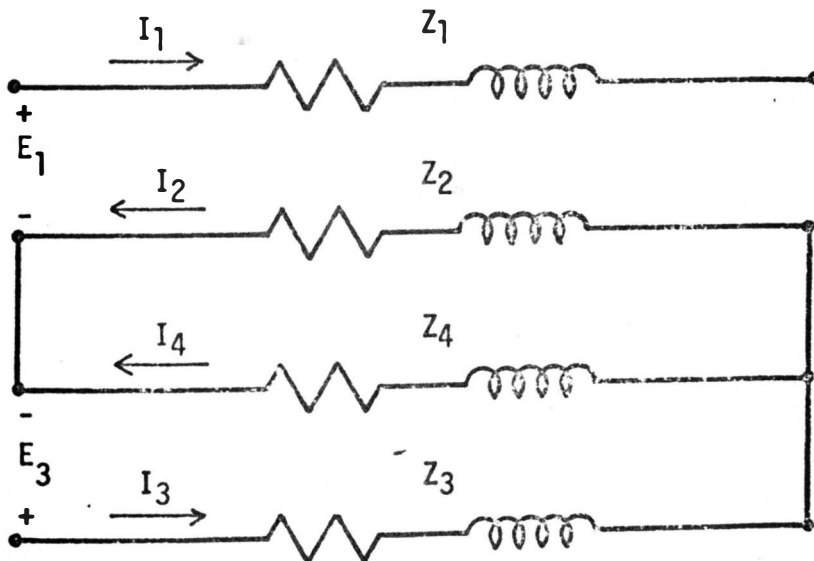

Figure (5-6)

CIRCUIT DIAGRAM FOR A PARALLELED OVERHEAD-UNDERGROUND
SINGLE-PHASE LINE WITH $I_1 = 0$

$$\psi_2 = 6.096 \times 10^{-5} \left[-I_1 \log_e \frac{1}{D_{12}} + I_2 \log_e \frac{1}{r_2'} + I_4 \log_e \right. \\ \left. \frac{1}{(D_{2a} D_{2b} D_{2c} D_{2d} D_{2e} D_{2f})^{1/s}} \right], \quad (5-18)$$

and

$$\psi_3 = 6.096 \times 10^{-5} \left[-I_1 \log_e \frac{1}{D_{1a}} + I_2 \log_e \frac{1}{D_{2a}} + I_4 \log_e \right. \\ \left. \frac{1}{(r_a D_{ab} D_{ac} D_{ad} D_{ae} D_{af})^{1/s}} \right]. \quad (5-19)$$

Substituting these expressions into equations (5-15) and (5-16) and eliminating all of the currents except I_1 , yields an equation in terms of E_1 and I_1 . This equation is given as

$$\frac{E_1}{I_1} = [R_1 + j 2.29 \times 10^{-2} \log_e \frac{D_{21}}{r_1'}] + C_1 [R_2 + j 2.29 \times 10^{-2} \\ \log_e \frac{D_{12}}{r_2'}] \quad (5-20)$$

where C_1 is equal to

$$\left[\frac{R_4}{s} + j 2.29 \times 10^{-2} \log_e \frac{D_{1a} (D_{2a} D_{2b} D_{2c} D_{2d} D_{2e} D_{2f})^{1/s}}{(r_a' D_{ab} D_{ac} D_{ad} D_{ae} D_{af})^{1/s} D_{12}} \right]$$

$$\left[R_2 + \frac{R_4}{s} + j 2.29 \times 10^{-2} \log_e \frac{(D_{2a} D_{2b} D_{2c} D_{2d} D_{2e} D_{2f})^{1/s} D_{2a}}{r_2' (r_a' D_{ab} D_{ac} D_{ad} D_{ae} D_{af})^{1/s}} \right].$$

Substituting the numerical values listed in table (5-1) into equation (5-20) results in a numerical value for the series impedance. Two numerical values were obtained for the series impedance. First, a case was considered where both the overhead circuit and the underground circuit consisted of #1/0 AWG aluminum conductors. The series impedance for this case was calculated to be equal to $0.317 + j 0.230$ ohms/1000 feet. The second value was obtained for both the overhead and underground circuits consisting of #2 AWG aluminum conductors. The series impedance for this case was found to be equal to $0.4698 + j 0.2324$ ohms/1000 feet.

The shunt admittance, when $I_3 = 0$, will now be considered. Since the neutral conductors of the two circuits are electrically connected in parallel, a portion of the charge on conductor 2 will exist on conductor 4. Therefore, the total capacitance which defines the shunt admittance consists of two parallel capacitances. These parameters were defined in Chapter IV. If the overhead circuit and the underground circuit consist of #1/0 AWG aluminum conductors, numerical values can be calculated for each of these capacitances. The proportion of charge on conductor 2 and on conductor 4 must be determined before the

capacitances can be evaluated. The voltage from conductor 1 to conductor 2 is equal to the voltage from conductor 1 to conductor 4. Therefore, equating these potentials yields an expression in terms of K_1 and K_2 . These constants describe the proportion of the charge on conductor 2 and conductor 4. Once this expression is determined, equation (4-20) can be applied to evaluate K_1 and K_2 individually. For #1/0 AWG aluminum conductors, $K_1 = -0.528$ and $K_2 = -0.472$.

The capacitance between conductor 1 and conductor 2 was determined to be $1.885 \times 10^{-3} \mu$ farads/1000 feet. The capacitance between conductor 1 and conductor 4 was determined to be $1.50 \times 10^{-3} \mu$ farads/1000 feet. Therefore, the total capacitance was calculated to be $3.38 \times 10^{-3} \mu$ farads/1000 feet. The shunt admittance was then calculated to be numerically equal to $0.0 + j 1.275 \times 10^{-6}$ mhos/1000 feet. Once again, the circuit just described can be represented by the nominal- π .

The last variation of figure (5-4) is a short circuit of the underground phase conductor to the underground neutral, with the current $I_1 = 0$. As before, a node equation representing the currents in the conductors can be written. This equation is

$$I_3 = I_2 + I_4. \quad (5-21)$$

This equation is true only when all of the current returns in the neutral conductors and not in the earth. Applying Kirchhoff's voltage law to figure (5-6), which represents the new short circuit, two loop equations can be written which will aid in the circuit solution. These equations are

$$E_3 = I_3 Z_3 + I_4 Z_4 \quad (5-22)$$

and

$$I_4 Z_4 = I_2 Z_2 \quad (5-23)$$

Since $I_1 = 0$, the equations for the flux linkages of conductors 2, 3, and 4, respectively, can be rewritten as

$$\psi_2 = 6.096 \times 10^{-5} \left[I_2 \log_e \frac{1}{r_2'} - I_3 \log_e \frac{1}{D_{23}} + I_4 \log_e \frac{1}{(D_{2a} D_{2b} D_{2c} D_{2d} D_{2e} D_{2f})^{1/6}} \right], \quad (5-24)$$

$$\psi_3 = 6.096 \times 10^{-5} \left[-I_2 \log_e \frac{1}{D_{23}} + I_3 \log_e \frac{1}{r_3'} - I_4 \log_e \frac{1}{(D_{3a} D_{3b} D_{3c} D_{3d} D_{3e} D_{3f})^{1/6}} \right], \quad (5-25)$$

and

$$\psi_4 = 6.096 \times 10^{-5} \left[I_2 \log_e \frac{1}{D_{2a}} - I_3 \log_e \frac{1}{D_{3a}} + I_4 \log_e \frac{1}{(r_a' D_{ab} D_{ac} D_{ad} D_{ae} D_{af})^{1/6}} \right]. \quad (5-26)$$

Substituting these equations into equation (5-22) and equation (5-23) and eliminating all of the currents except I_3 , results in an equation in terms of E_3 and I_3 . This equation is

$$\frac{E_3}{I_3} = [R_3 + j 2.29 \times 10^{-2} \log_e \frac{D_{3a}}{r_3'}] + C_2 [\frac{R_4}{s} + j 2.29 \times 10^{-2} \log_e$$

$$\frac{(D_{3a}D_{3b}D_{3c}D_{3d}D_{3e}D_{3f})^{1/s}}{(r_a' D_{ab}D_{ac}D_{ad}D_{ae}D_{af})^{1/s}}] \quad (5-27)$$

where C_2 is equal to

$$\frac{[R_2 + j 2.29 \times 10^{-2} \log_e \frac{D_{23}D_{2a}}{r_2'D_{3a}}]}{[\frac{R_4}{s} + R_2 + j 2.29 \times 10^{-2} \log_e \frac{D_{2a} (D_{2a}D_{2b}D_{2c}D_{2d}D_{2e}D_{2f})^{1/s}}{r_2' (r_a' D_{ab}D_{ac}D_{ad}D_{ae}D_{af})^{1/s}}]} .$$

Table (5-1) was utilized to calculate numerical values for three cases. In the first case, the underground cable consisted of a #1/0 AWG aluminum phase conductor and the overhead circuit consisted of two #1/0 AWG aluminum conductors. The series impedance was calculated to be $0.3857 + j 0.176$ ohms/1000 feet. The second case varied from the first by changing the #1/0 AWG aluminum overhead conductors to #2 AWG aluminum conductors. The series impedance was evaluated and found to be $0.387 + j 0.178$ ohms/1000 feet. Finally, both circuits were assumed to be

comprised of #2 AWG aluminum conductors. The series impedance for this case was found to be $0.52 + j 0.15$ ohms/1000 feet.

The shunt admittance for this particular circuit would be determined only by the capacitance between the phase conductor and the grounded conducting shield of the underground cable. This would be true since the electric field terminates on the oppositely charged shield. Again, the equivalent circuit would be the nominal- π equivalent shown in figure (5-1).

Table (5-2)
 NUMERICAL VALUES OF THE SERIES IMPEDANCE AND
 SHUNT ADMITTANCE FOR VARIOUS CIRCUITS

<u>Type of Circuit and Conductors</u>	<u>Z</u> (Ohms/1000 Feet)	<u>Y</u> (Mhos/1000 Feet)
Single-phase overhead		
#1/0 AWG aluminum	0.362 + j 0.282	0.0 + j 5.4 x 10 ⁻⁷
#2 AWG aluminum	0.574 + j 0.294	0.0 + j 5.18 x 10 ⁻⁷
Single-phase underground		
#1/0 AWG aluminum	0.6805 + j 0.0346	0.0 + j 1.6 x 10 ⁻⁵
#2 AWG aluminum	0.787 + j 0.0362	0.0 + j 1.39 x 10 ⁻⁵
Parallel single-phase underground-overhead circuits, I₃ = 0		
#1/0 AWG aluminum	0.317 + j 0.230	0.0 + j 1.275 x 10 ⁻⁶
#2 AWG aluminum	0.4698 + j 0.2324	
Parallel single-phase underground-overhead circuits, I₁ = 0		
#1/0 AWG aluminum	0.3857 + j 0.176	0.0 + j 1.6 x 10 ⁻⁵
#2 AWG aluminum	0.520 + j 0.15	0.0 + j 1.39 x 10 ⁻⁵
#1/0 AWG aluminum overhead	0.387 + j 0.178	0.0 + j 1.39 x 10 ⁻⁵
#2 AWG aluminum underground		

Chapter VI

DERIVATION OF THE CIRCUIT IMPEDANCE OF A SINGLE-PHASE
UNDERGROUND CIRCUIT WITH EARTH-RETURN AND A
PARALLELED SINGLE-PHASE UNDERGROUND-OVERHEAD CIRCUIT

In a previous chapter, equations were developed for the inductance of a single-phase underground circuit and for a paralleled single-phase underground and overhead circuit. These equations were based on the assumption that all of the current in the phase conductor would return in the neutral conductors, or that none of the current would return in the earth. However, it is generally accepted that a portion of the phase current returns in the earth in a conventionally grounded distribution system. Formulas have been developed by other authors which describe the impedance of conductors with earth-return for overhead circuits.⁶ These equations were based on information developed by Dr. John R. Carson.⁸ Recently, these equations have been modified to describe the impedances of concentric neutral underground cables.¹² In this chapter, these equations, which have been derived in Appendix B, will be used to describe a single-phase underground circuit and a single-phase overhead circuit.

The underground single-phase circuit is comprised of a phase conductor and a concentric neutral return path. The circuit diagram for this case is illustrated in figure (5-3). If the earth-return is not neglected, another return path for the phase current must be considered. Figure (6-1) represents a single-phase concentric neutral underground circuit with earth-return. The impedances shown in figure (6-1)

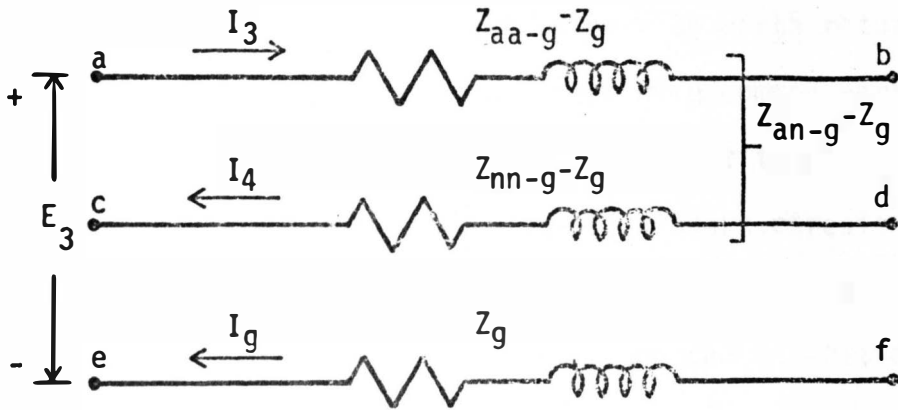

Figure (6-1)

CIRCUIT DIAGRAM OF AN UNDERGROUND SINGLE-PHASE LINE
WITH THE EARTH-RETURN PATH RETAINED

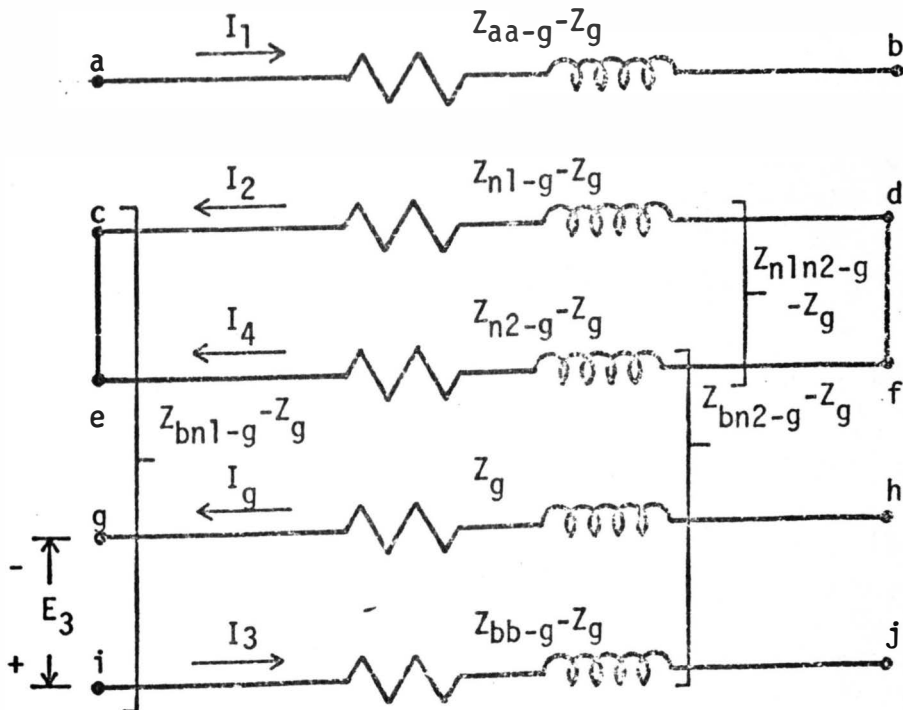

Figure (6-2)

CIRCUIT DIAGRAM OF A PARALLELED OVERHEAD-UNDERGROUND
SINGLE-PHASE LINE WITH THE EARTH-RETURN PATH RETAINED

represent the self-impedances of each conductor with earth-return and the mutual impedance between the two conductors with common earth-return. These parameters are defined in Appendix B. The identity of the earth impedance, Z_g , is retained in figure (6-1). If a short circuit is applied across terminals b, d, and f, and another short circuit across terminals c and e, the following voltage equations can be written:

$$E_3 = I_3 (Z_{aa-g} - Z_g) - I_4 (Z_{an-g} - Z_g) + I_g Z_g \quad (6-1)$$

and

$$0 = I_3 (Z_{an-g} - Z_g) - I_4 (Z_{nn-g} - Z_g) + I_g Z_g \quad (6-2)$$

The current, I_g , can be expressed as

$$I_g = I_3 - I_4 \quad (6-3)$$

Therefore, equations (6-1) and (6-2) can be reduced to

$$E_3 = I_3 Z_{aa-g} - I_4 Z_{an-g} \quad (6-4)$$

and

$$0 = I_3 Z_{an-g} - I_4 Z_{nn-g} \quad (6-5)$$

The series impedance of an underground single-phase circuit can be evaluated by utilizing equations (6-4) and (6-5). Solving these two equations for the single-phase impedance of the circuit yields

$$Z = \frac{E_3}{I_3} = Z_{aa-g} - \frac{Z_{an-g}^2}{Z_{nn-g}} \quad \text{ohms/1000 feet.} \quad (6-6)$$

Substituting equations (B-20), (B-23), and (B-34) into equation (6-6) results in an expression in terms of geometric distances and resistivity.

A computer program was written, which would solve equation (6-6) given information from table (5-1) and values of resistivity. This program was designed to yield results for varying values of resistivity. The resistivity was varied since the conductivity of the soil was inversely proportional to the resistivity. This parameter was varied between values of 100 meter-ohms and 1000 meter-ohms for cable sizes of #1/0 AWG aluminum and #2 AWG aluminum. The circuit impedance was calculated for each value of resistivity. The real part of Z was plotted in graph (6-1) and the imaginary part of Z was plotted in graph (6-2) as the resistivity was increased in steps of 100 meter-ohms. There was a slight increase in magnitude of the circuit impedance as the resistivity was increased.

The circuit impedance for an underground single-phase circuit, paralleled with an overhead single-phase circuit, can be developed by applying the same procedures as were applied previously. The circuit diagram for this case is shown in figure (6-2). Once again, the identity of the earth-return is retained. The current in the overhead phase conductor is assumed to be equal to zero. The mutual impedances between the conductors with earth-return are shown in figure (6-2). These impedances are defined by equations (B-22) and (B-23) in Appendix B. If a short circuit is applied across the terminals d, f, h, and j and another short circuit across e and g, the following voltage equations can be written:

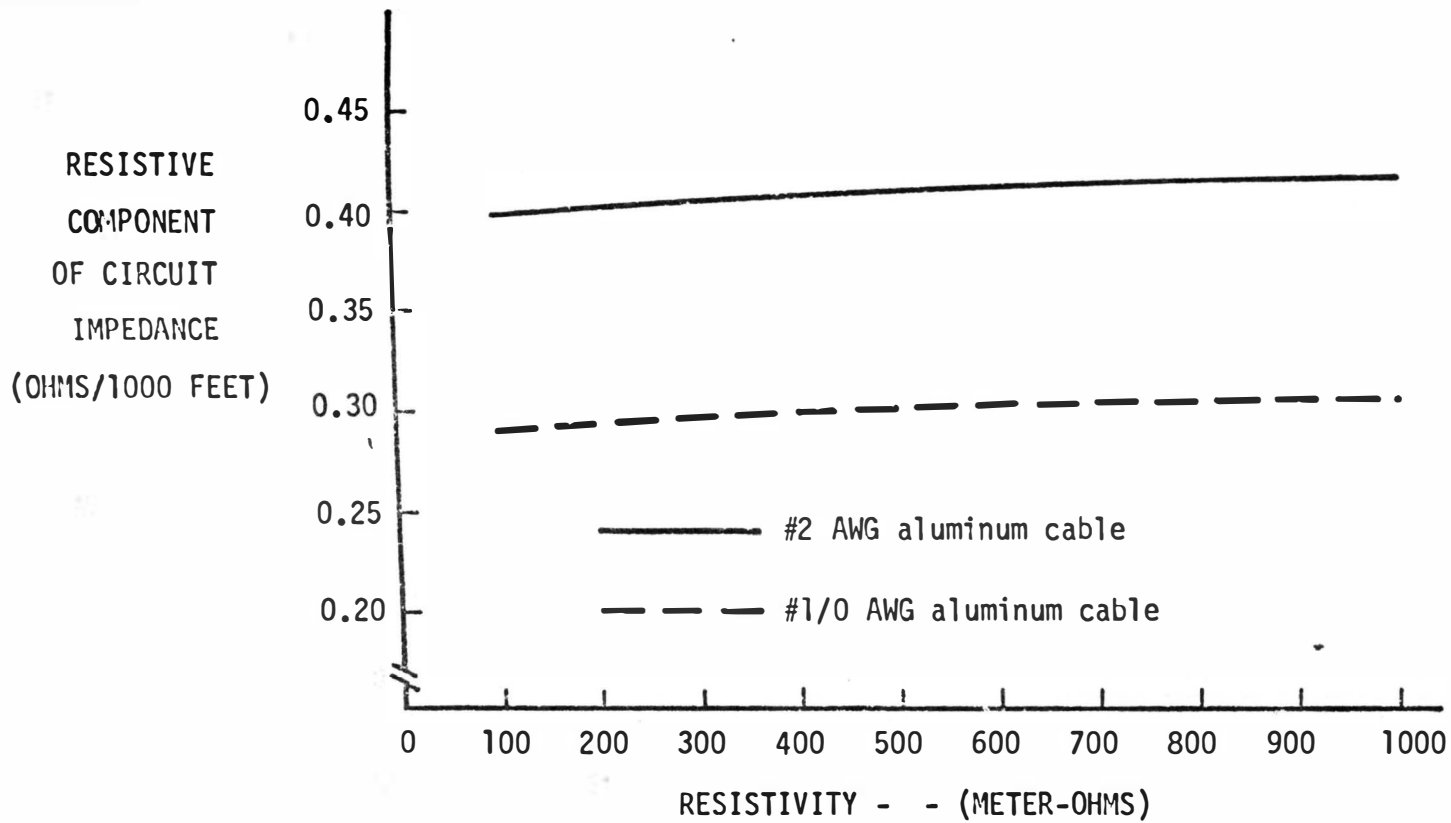

Graph (6-1)

RESISTIVE COMPONENT OF THE CIRCUIT IMPEDANCE VS. RESISTIVITY

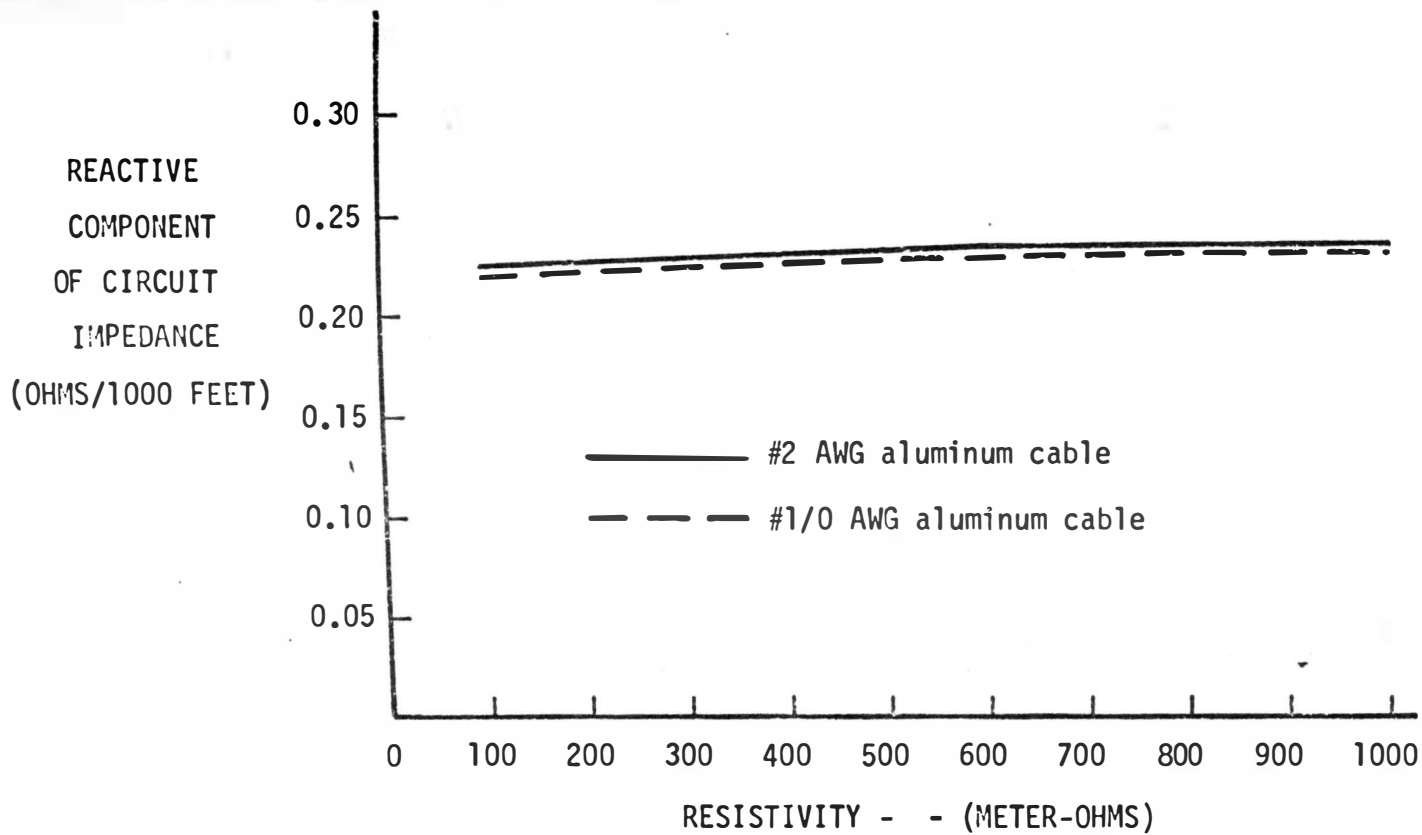

Graph (6-2)

REACTIVE COMPONENT OF THE CIRCUIT IMPEDANCE VS. RESISTIVITY

$$E_3 = I_3 (Z_{bb-g} - Z_g) - I_4 (Z_{bn2-g} - Z_g) - I_2 (Z_{bn1-g} - Z_g) + I_g Z_g, \quad (6-7)$$

$$0 = I_3 (Z_{bn2-g} - Z_g) - I_4 (Z_{n2-g} - Z_g) - I_2 (Z_{n1n2-g} - Z_g) + I_g Z_g, \quad (6-8)$$

and

$$0 = I_3 (Z_{bn1-g} - Z_g) - I_4 (Z_{n1n2-g} - Z_g) - I_2 (Z_{n1-g} - Z_g) + I_g Z_g. \quad (6-9)$$

In this case, the current I_g can be expressed as

$$I_g = I_3 - I_4 - I_2. \quad (6-10)$$

These equations can be solved simultaneously to eliminate all of the currents but I_3 . The equation which results is given in terms of E_3 and I_3 . The circuit impedance can be obtained by dividing E_3 by I_3 .

The expression which results is

$$\frac{E_3}{I_3} = \left[Z_{bb-g} - \frac{Z_{bn1-g}^2}{Z_{n1-g}} \right] - \frac{\left[Z_{n2-g} - \frac{Z_{bn1-g} Z_{n1n2-g}}{Z_{n1-g}} \right]}{\left[Z_{n2-g} - \frac{Z_{n1n2-g}^2}{Z_{n1-g}} \right]} \left[Z_{n2-g} - \frac{Z_{bn1-g} Z_{n1n2-g}}{Z_{n1-g}} \right]$$

ohms/1000 feet.

$$(6-11)$$

Due to the spacing distance between conductor 2 and conductor 3, and conductor 2 and conductor 4, the mutual impedances between these conductors with earth-return can be assumed to be equal. The circuit impedance for this case was calculated by slide rule for two different conductor sizes. First, it was assumed that the paralleled circuit consisted of #1/0 AWG aluminum conductors. The circuit impedance was calculated to be $0.295 + j 0.247$ which was consistent with previous results. When the circuit was assumed to be comprised of #2 AWG aluminum conductors, the circuit impedance was calculated to be $0.3984 + j 0.2462$. Both of these values were calculated for a resistivity of 100 meter-ohms.

Sioux Valley Empire Electric Association, located at Colman, South Dakota, requested that short circuit tests be made on various lengths of installed underground cable. The test which was performed required the phase conductor and the neutral to be short-circuited. A voltage was applied to the shorted cable and the voltage, current, and watts were measured. Table (6-1) contains information from one of these tests. From the measured quantities it was possible to calculate the real and imaginary components of the circuit impedance. The results of this test will be discussed in the following chapter.

Table (6-1)
SHORT CIRCUIT TEST DATA

LOCATION: Near Valley Springs, South Dakota

DISTANCE: 9,210 feet

E (VOLTS)	I (AMPS)	P (KW)	Z (OHMS)	COS θ (RADIANS)	R (OHMS PER 1000 FEET)	X (OHMS PER 1000 FEET)
45.0	11.44	0.48	3.94	.939	.402	.146
49.9	12.72	0.60	3.92	.945	.404	.138
55.0	13.96	0.79	3.94	.935	.399	.147
72.0	18.0	1.20	4.01	.925	.404	.152
80.0	20.0	1.50	4.00	.939	.408	.148
84.9	21.1	1.64	4.02	.918	.399	.172
90.0	22.5	1.84	4.0	.910	.396	.179
95.0	23.8	2.05	3.99	.908	.393	.183
100.0	25.0	2.30	4.0	.918	.398	.171
105.0	26.4	2.51	3.98	.908	.392	.183
109.9	27.5	2.75	3.99	.914	.396	.176
112.0	28.1	2.88	3.98	.914	.396	.175

Chapter VII

DISCUSSION OF THE RESULTS

A single-phase concentric neutral cable consists of a phase conductor and a neutral conductor. Equation (3-11) represents the inductive reactance of the phase conductor in terms of geometric distances. These distances, which are tabulated in table (5-1), were substituted into this equation. The calculated value of the inductive reactance for a #2 AWG aluminum conductor was found to be 0.0335 ohms/1000 feet. The calculated value for a #1/0 AWG aluminum conductor was found to be 0.0300 ohms/1000 feet. Both of these values are based on the assumption that all of the phase current returns in the neutral conductor. These values were found to be the same values given in the Rome Cable URD Technical Manual.²¹ Equation (B-20) represents an expression for the self-impedance of a conductor with earth-return. This equation was solved utilizing data from table (5-1). The inductive reactance of a #2 AWG aluminum conductor with earth-return was found to be 0.2928 ohms/1000 feet. The inductive reactance of a #1/0 AWG aluminum conductor with earth-return was found to be 0.28694. Both of these values were calculated for a value of earth resistivity equal to 100 meter-ohms. These calculations indicated that when the earth-return was considered, the reactance of the cable increased.

Some authors assume that the inductive reactance of the concentric neutral is equal to zero.¹³ Equation (3-21) represents the inductive reactance of the neutral conductor of a concentric neutral cable. As before, these equations were solved utilizing the data in table (5-1).

The inductive reactance, neglecting the earth-return, of a #1/0 AWG aluminum conductor was found to be 0.0043 ohms/1000 feet. The value calculated for a #2 AWG aluminum conductor was found to be 0.0040 ohms/1000 feet. When the earth-return was considered, the value for the inductive reactance of a #1/0 AWG aluminum conductor was found to be 0.26798 ohms/1000 feet. The value obtained for the inductive reactance of a #2 AWG aluminum conductor was found to be 0.26963 ohms/1000 feet.

These magnitudes reflect the fact that the true inductive reactance of the concentric neutral is not equal to zero. When the earth-return is neglected, the inductive reactance of the return current is approximately 11.8% of the total inductive reactance of a single-phase circuit.

The equations which were derived to describe the inductive reactance of a concentric neutral cable were used to calculate the series impedance of the single-phase underground circuit. These equations neglect the earth-return path. The series impedance for a #1/0 AWG aluminum conductor was calculated to be $0.6805 + j 0.0346$ ohms/1000 feet. The value obtained for a #2 AWG aluminum cable was $0.787 + j 0.0362$ ohms/1000 feet. As expected, the resistive term increased substantially since a smaller cable was used. The reactive component did not change significantly.

The series impedance of the same single-phase circuit was calculated using the formulas derived in Appendix B. These formulas consider the earth as a return path for the current. The circuit impedance for a #1/0 AWG aluminum cable and a #2 AWG aluminum cable was calculated for values of resistivity ranging from 100 meter-ohms to 1000 meter-ohms. The reactive component of the #1/0 AWG aluminum cable ranged

from 0.2210 ohms/1000 feet to 0.23206 ohms/1000 feet. This increase in inductive reactance represented only a 4.7% rise over a range of 900 meter-ohms. The values of circuit impedance for a #2 AWG aluminum cable ranged from 0.22528 ohms/1000 feet to 0.23621 ohms/1000 feet. This increase represented a 4.68% rise over a range of 900 meter-ohms. The relative magnitudes and the rise in magnitudes over a range of varying resistivities are displayed in graph (6-1). Graph (6-2) represents the magnitudes of the resistive components of the circuit impedances for both the #1/0 AWG aluminum cable and the #2 AWG aluminum cable as the resistivity increases. This graph shows a rise in resistance of approximately 3.7% for #2 AWG aluminum cable and a rise of approximately 5.1% for #1/0 AWG aluminum cable. The magnitude of the reactance with earth-return was found to be much greater than the reactance neglecting an earth-return. However, the resistive component of the circuit impedance with earth-return was found to have a value which was smaller than that of the resistive component without an earth-return.

The information that was measured in the field was tabulated in table (6-1). The cable that was tested consisted of a #2 AWG aluminum cable and six #14 AWG annealed copper strands which comprised the neutral. The data was accumulated over a range of voltages. No particular pattern was observed with an increase in voltage. The values obtained were relatively close in magnitude to the results obtained from the computer program which solved the circuit impedance with earth-return. The relative magnitudes of the field data, when compared to the calculated values, might suggest that the soil in the test area had

a resistivity of approximately 100 meter-ohms. Various methods have been devised to measure the resistivity of the earth. If this measurement was made before the tests were conducted, relative magnitudes of the components of the circuit impedance could be calculated.

The ratio of the current in the neutral to the current in the phase conductor, for a circuit considering an earth-return, can be written as

$$\frac{I_4}{I_3} = - \frac{Z_{an-g}}{Z_{nn-g}} . \quad (7-1)$$

If equations (B-23) and (B-24) are substituted into equation (7-1), results can be obtained for various values of resistivity and cable dimensions.

This calculation was performed using data obtained from the computer program that was written. The cable that was chosen was a #2 AWG aluminum cable. The resistivity of the earth was assumed to be 100 meter-ohms. The value of Z_{an-g} was computed to be $0.01805 + j 0.258$ ohms/1000 feet and the value of Z_{nn-g} was found to be $0.517 + j 0.269$ ohms/1000 feet. Substituting these values into equation (7-1) and simplifying, resulted in a ratio of $0.233 + j 0.38$. The magnitude of this ratio was calculated to be approximately .4455. This means that about 44.5% of the phase current returns in the neutral conductor. A magnitude of this size indicates that the assumption of 40% return current in the neutral conductor, as suggested by the REA, was justified. This also means that a significant savings in the cost of the

cable can be realized by the utility since a reduced neutral can be specified.

Equations (3-30), (3-32), (3-37), and (3-42) represent the inductance of each conductor, with earth-return, of a physically paralleled overhead-underground single-phase circuit. The neutrals of these two circuits are electrically connected in parallel. These equations are dependent on the geometric distances of the cable and the magnitude of the current in each conductor. Since these equations are dependent on the current, they can be altered to describe other circuits. By assuming I_3 and I_4 to be equal to zero, the equations simplify to equations (A-27) and (A-28) which represent the inductance of conductor 1 and conductor 2 of an overhead single-phase circuit. Likewise, if I_1 and I_2 are assumed to be equal to zero, the equations for the inductance of an underground single-phase circuit can be defined.

In order to investigate whether the neutral of the underground cable had a significant effect on the circuit impedance of the overhead circuit, I_3 was assumed to be equal to zero. This meant that the returning phase current would have to split in some manner between the two paralleled neutrals. Values for the circuit impedance were calculated for both a #1/0 AWG aluminum conductor and a #2 AWG aluminum conductor. The results of these calculations were listed in table (5-2). In comparing the results of this circuit with that of an overhead single-phase circuit, it was found that there appeared to be only a slight decrease in the relative magnitude of the components.

This same procedure was applied to the underground circuit. The results were again listed in table (5-2). In this case, it was found

that the magnitude of the reactive component increased substantially and the resistive component decreased. This would suggest that circuit impedance would be significantly altered when these neutrals are paralleled.

If the current in each conductor is known, the circuit impedance for the case where both the underground and the overhead circuits are energized could be obtained. However, if these currents are not known quantities, the problem of calculating a circuit impedance increases. The complication results because the expression for the circuit impedance contains more than one unknown. This is one area which requires further research.

The capacitance of an underground cable exists between the phase conductor and the grounded semiconducting shield around the insulation. The expression which was derived for the capacitance is given in equation (4-11). From this equation, it is evident that the magnitude of the capacitance is dependent on the thickness of the insulation and the magnitude of the dielectric constant.

The cable which was tested consisted of a high molecular weight polyethylene insulation. The relative dielectric constant for this material was assumed to be 2.3. Values were obtained for the capacitance of the two sizes tested. The #1/0 AWG aluminum cable was found to have a capacitance of $4.23 \times 10^{-2} \mu$ farads/1000 feet. The #2 AWG aluminum cable was found to have a capacitance of $3.69 \times 10^{-2} \mu$ farads/1000 feet. This data substantiates the fact that as the separation of the conductors increases, the capacitance decreases. With an increase in capacitance, the shunt admittance of the equivalent circuit will

increase. Therefore, as the phase conductor increases in size, the shunt admittance decreases in magnitude. Magnitudes of the shunt admittance for the single-phase underground circuit were given in table (5-2).

The capacitance of the paralleled underground-overhead single-phase circuit, when $I_1 = 0$, is given as the capacitance of the underground cable. The values derived for the underground cable capacitance are applicable in this case. The shunt admittance of the equivalent circuit varies similarly, as well.

The capacitance of the paralleled underground-overhead single-phase circuit, when $I_3 = 0$, is given as the equivalent capacitance of two parallel capacitances. Equations (4-21) and (4-22) represent the two parallel capacitances. Like the expression derived for the capacitance of an underground cable, these equations are dependent on the geometric spacing and the magnitude of the dielectric constant. However, these equations are also dependent on the manner in which the charge splits between conductor 2 and conductor 4, since they are connected together. Normally, it would appear that the capacitance between conductor 1 and conductor 4 would be very small due to the large separation distance.

Numerical values were obtained for the constants K_1 and K_2 which indicate the proportion of charge, Q_1 , on conductor 2 and conductor 4. The value of K_1 was found to be -0.528 and the value of K_2 was found to be -0.472. The capacitance between conductor 1 and conductor 2 was calculated to be $1.885 \times 10^{-3} \mu$ farads/1000 feet. The capacitance between conductor 1 and conductor 4 was calculated to be 1.5×10^{-3}

μ farads/1000 feet. The equivalent capacitance was calculated to be $3.38 \times 10^{-3} \mu$ farads/1000 feet. The capacitance between conductor 1 and conductor 2, neglecting conductor 4, was calculated and found to be equal to $1.05 \times 10^{-2} \mu$ farads/1000 feet. Comparing the equivalent capacitance with the capacitance between conductors 1 and 2 would suggest that a paralleled neutral would tend to decrease the capacitance due to a split in the charge.

Throughout this thesis, one particular problem existed. It was difficult to verify some of the results that were obtained. Therefore, it is recommended that if this research is extended, one span of paralleled single-phase overhead-underground cable be constructed.

Appendix A

This appendix develops an expression for the inductance of two overhead conductors separated a distance "D" apart. This development will include the derivation of a fundamental expression for the inductance parameter, the derivation of the internal and external inductance of a conductor, and finally, an application of these derivations to an overhead circuit.

A general expression defining inductance can be developed by considering the magnetic field of a conductor. The magnetic field of a conductor is described by the flux linkages, which radiate concentrically outward from the conductor. An induced voltage is produced if there is a rate of change of these flux linkages. This voltage is given as

$$e = \frac{d\mathcal{F}}{dt} \quad \text{volts,} \quad (\text{A-1})$$

where e is the induced voltage and \mathcal{F} represents the flux linkages in weber-turns. A magnetic field can be produced by either a changing electric field or a current.²² If the current is a changing current, then the magnetic field which is produced will also be changing. Therefore, the number of the flux linkages, which describe the changing magnetic field, will be proportional to the current causing the magnetic field if a constant permeability is assumed.¹⁷ The induced voltage which is produced can now be described as

$$e = L \frac{di}{dt} \quad \text{volts,} \quad (\text{A-2})$$

where L in henrys is the constant of proportionality and i is the current in amps. Equating equations (A-1) and (A-2) and solving for L results in

$$L = \frac{d\mathcal{F}}{di} \quad \text{henrys.} \quad (\text{A-3})$$

Since a constant permeability is assumed, this expression can be re-written as

$$L = \frac{\mathcal{F}}{i} \quad \text{henrys} \quad (\text{A-4})$$

or

$$\mathcal{F} = Li \quad \text{flux linkages.}$$

Here, the terms i and \mathcal{F} represent instantaneous quantities. If these terms are expressed as phasor quantities, the resulting expression is

$$\mathcal{F} = LI \quad \text{weber-turns.} \quad (\text{A-5})$$

From the above expression, it can be seen that if the total flux linkages for a conductor are known and the current through that conductor is known, then the inductance can be determined.

The total flux linkages of a conductor consists of an internal and external component. With the aid of figure (A-1), the internal component of the flux linkages will be obtained. The current enclosed within a conductor can be expressed as

$$\oint H \cdot ds = I \quad \text{amp-turns,} \quad (\text{A-6})$$

where H is the magnetic field intensity in ampere-turns per meter, s is the distance along the path in meters, and I is the enclosed current

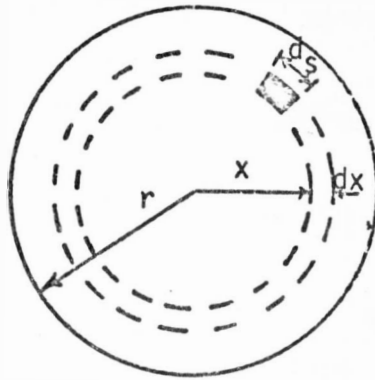

Figure (A-1)

CROSS SECTION OF A CONDUCTOR FOR DETERMINING
THE INTERNAL FLUX LINKAGES

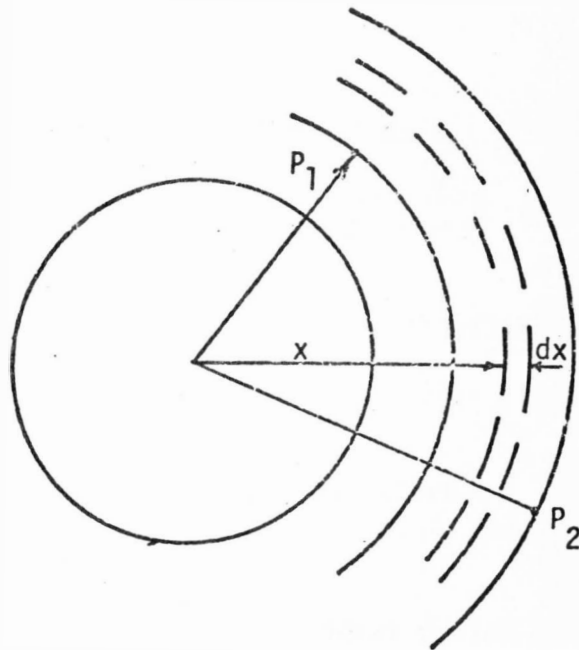

Figure (A-2)

A CONDUCTOR AND TWO EXTERNAL POINTS FOR
DETERMINING THE EXTERNAL FLUX LINKAGES

in amperes. Consider the current I_x flowing through the enclosed section of the conductor. The magnetic field intensity in this area would be H_x , and the expression for the enclosed current would be

$$\oint H_x ds = I_x \quad \text{amp-turns.} \quad (\text{A-7})$$

If there is uniform current density, the current I_x can be expressed as

$$I_x = \frac{\pi x^2}{\pi r^2} I, \quad (\text{A-8})$$

which is a fraction of the total current enclosed. Since $\oint ds = 2\pi x$, equation (A-7) can be expressed as

$$2\pi x H_x = \frac{x^2}{r^2} I. \quad (\text{A-9})$$

The flux density of a conductor, B , is defined as

$$B = \mu H \quad \text{webers/meters}^2 \quad (\text{A-10})$$

where μ is the permeability constant. The permeability constant for air is $4\pi \times 10^{-7}$ henrys/meter. Therefore, the flux density is

$$B_x = \mu H_x = \frac{\mu x I}{2\pi r^2} \quad \text{webers/meters}^2. \quad (\text{A-11})$$

Since the flux per meter of length is the magnetic flux density times the cross-sectional area of the element normal to the flux lines, $d\phi$, which is the flux per meter of length, can be expressed as

$$d\phi = B_x dx = \frac{\mu x I}{2\pi r^2} dx \quad \text{webers/meter of length.}^{17} \quad (\text{A-12})$$

Finally, the flux linkages per meter of length can be expressed as a product of the flux per meter and the fraction of current linked, which results in

$$d\psi = \frac{\mu I x^3}{2\pi r^4} dx \quad \text{weber-turns/meter.}^{17} \quad (\text{A-13})$$

In order to find the internal flux of the conductor in figure (A-1), this expression must be integrated from the center of the conductor to the outer edge of the conductor. The resulting expression is

$$\psi_{\text{int}} = \frac{\mu I}{8\pi} \quad \text{weber-turns/meter} \quad (\text{A-14})$$

which simplifies to

$$\psi_{\text{int}} = \frac{I}{2} \times 10^{-7} \quad \text{weber-turns/meter.} \quad (\text{A-15})$$

Utilizing equation (A-5), the internal inductance can be expressed as

$$L_{\text{int}} = \frac{1}{2} \times 10^{-7} \quad \text{henry/meter.} \quad (\text{A-16})$$

The flux linkages external to the conductor can be determined in the same manner as the internal flux linkages. However, the current enclosed by the path of integration is the total current, as shown by figure (A-2). The expressions for the field intensity, flux density, flux per unit length, and the flux linkages would be:

$$H = \frac{\text{magnetomotive force}}{\text{length of conductor}} = \frac{I}{2\pi x} \quad \text{amp-turns/meter,} \quad (\text{A-17})$$

$$B = \mu H = \frac{\mu I}{2\pi x} \quad \text{webers/meters}^2, \quad (\text{A-18})$$

$$d\phi = Bdx = \frac{\mu I}{2\pi x} dx \quad \text{webers/meter of length}, \quad (\text{A-19})$$

and

$$\psi_{12} = \int_{D_1}^{D_2} d\phi = \int_{D_1}^{D_2} \frac{\mu I}{2\pi x} dx = \frac{\mu I}{2\pi} \log_e \frac{D_2}{D_1} \quad \text{weber-turns/meter.} \quad (\text{A-20})$$

The external inductance can be determined using equation (A-5). Since the relative permeability of air, μ_r , is equal to 1, the expression for the external component of inductance between two points becomes

$$L_{12} = 2 \times 10^{-7} \log_e \frac{D_2}{D_1} \quad \text{henrys/meter.} \quad (\text{A-21})$$

The total inductance of a conductor is equal to the sum of the internal and external components of inductance. Methods of obtaining these components have been developed above, and will now be applied to the situation of an overhead single-phase power line.

The problem to be solved is shown in figure (A-3). Conductor 2 is the return circuit for conductor 1, and it is assumed that these currents are equal and opposite in direction. The inductance of conductor 1 can be calculated as before, by summing up all of the flux linkages and then applying equation (A-5). In general terms, the sum of the flux linkages can be written as

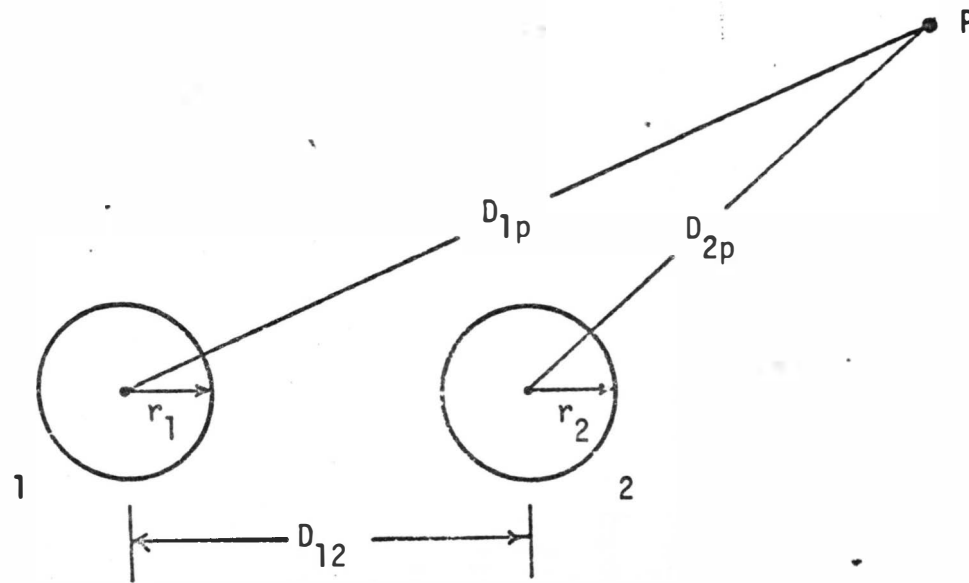

Figure (A-3)

CROSS SECTION OF TWO PARALLEL CONDUCTORS AND AN EXTERNAL POINT P

Total flux linkages = Internal flux linkages of conductor 1 due to the current in conductor 1 + external flux linkages of conductor 1 due to the current in conductor 1 + external flux linkages of conductor 1 due to the current in conductor 2.

Initially, this can be expressed as

$$\int d\psi_1 = \frac{I_1}{2} \times 10^{-7} + \frac{\mu I_1}{2\pi} \int_{r_1}^{D_{1p}} \frac{dx}{x} - \frac{\mu I_2}{2\pi} \int_{D_{12}}^{D_{2p}} \frac{dx}{x} \quad (\text{A-22})$$

where the point "p" represents a finite point in space defining a distance between that point and each of the conductors in the system. The negative sign which appears in equation (A-22) is a result of the direction of the current in conductor 2. After integrating and simplifying equation (A-22), the equation for the flux linkages of conductor 1 becomes

$$\psi_1 = \frac{I_1}{2} \times 10^{-7} + 2 \times 10^{-7} I_1 \log_e \frac{D_{1p}}{r_1} - 2 \times 10^{-7} I_2 \log_e \frac{D_{2p}}{D_{12}} \quad (\text{A-23})$$

If $2I_1 \times 10^{-7}$ is factored out of equation (A-23) and if it is recognized that the $\log_e e^{\frac{1}{4}} = \frac{1}{4}$, then a new expression for the flux linkages of conductor 1 can be generated. This expression is

$$\psi_1 = 2 \times 10^{-7} [I_1 \log_e \frac{D_{1p}}{r_1} - I_2 \log_e \frac{D_{2p}}{D_{12}}] \quad (\text{A-24})$$

where $r_1' = r_1 e^{-\frac{1}{4}}$. Since the return current is equal in magnitude to the phase current and the natural logarithm of a quotient can be expressed as a difference of two logarithmic quantities, equation (A-24) can be simplified to yield

$$\psi_1 = 2 \times 10^{-7} \left[I_1 \log_e \frac{D_{12}}{r_1'} + I_1 \log_e \frac{D_{1p}}{D_{2p}} \right]. \quad (\text{A-25})$$

As the point "p" moves farther and farther away from the conductor, the quotient of $\frac{D_{1p}}{D_{2p}}$ approaches unity. Since the natural logarithm of unity is zero, the final expression for the flux linkages of conductor 1 becomes

$$\psi_1 = 2 \times 10^{-7} I_1 \log_e \frac{D_{12}}{r_1'} \quad \text{weber-turns.} \quad (\text{A-26})$$

Substituting equation (A-26) into equation (A-5) yields the expression for the inductance of conductor 1 which is given as

$$L_1 = 2 \times 10^{-7} \log_e \frac{D_{12}}{r_1'} \quad \text{henrys/meter.} \quad (\text{A-27})$$

Similarly, the inductance of conductor 2 can be developed to yield

$$L_2 = 2 \times 10^{-7} \log_e \frac{D_{12}}{r_2'} \quad \text{henrys/meter.} \quad (\text{A-28})$$

The inductance of the circuit comprised of two parallel conductors, separated by a distance "D", is given as the sum of the total inductance

of each conductor. The inductance of the circuit is given as

$$L_{\text{TOTAL}} = 2 \times 10^{-7} \log_e \frac{D_{12}^2}{r_1' r_2'} \quad \text{henrys/meter.} \quad (\text{A-29})$$

This equation represents the inductance for two parallel solid conductors separated by a distance "D". If these conductors are stranded, then the inductance of each strand must be calculated. In order to obtain an expression for the total inductance of "n" electrically parallel strands, the following equation is applied:

$$L_{\text{TOTAL}} = \frac{L_{\text{ave}}}{n^2} \quad (\text{A-30})$$

where L_{ave} is the average inductance of the "n" strands.

Appendix B

R. C. Ender published a paper in 1971 adapting the equations known as Carson's formulas to describe underground cables.¹² Ender used the simplified equations found in Edith Clarke's Volume I for the basis of his work.⁶

The work that Clarke presented was a simplified version of the original formulas presented by Dr. Carson.⁵ In a very general form, Clarke presented these formulas as

$$Z_{aa-g} = z + j2\omega \log_e \frac{4h_a}{d} + 4\omega(P + jQ) = (r_c + R_{aa-g}) + j(\chi_{aa-g} + x_i) \quad (B-1)$$

$$Z_{ab-g} = j2\omega \log_e \frac{S_{ab}}{s_{ab}} + 4\omega(P + jQ) = R_{ab-g} + jX_{ab-g} \quad (B-2)$$

where

$z = r_c + jx_i$ = conductor internal impedance in nanoohms per centimeter

h_a, h_b = height of "a" and "b" above ground, as shown in figure (B-1), in centimeters

d = diameter of conductor in centimeters

s = distance between conductors in centimeters

S = distance from one conductor to the image of the other, assuming a perfectly conducting earth, in centimeters

$\omega = 2\pi f$

f = frequency in Hertz

P = correction factor for resistance in nanoohms per centimeter

Q = correction factor for reactance in nanoohms per centimeter.

The subscripts "a" and "b" refer to the cables in question and the subscript "g" indicates a ground return path. Therefore, the term Z_{aa-g} indicates the self-impedance of cable "a" with an earth-return. The term Z_{ab-g} indicates a mutual impedance between the conductors "a" and "b", with a common earth-return.

Carson assumed that the internal reactance, x_i , which is a part of the total internal impedance, z , could be neglected without appreciable error.⁵ Therefore, the internal impedance was represented only as a resistance. The self-impedance of a conductor with earth-return is given as the sum of the conductor internal impedance and the component of self-impedance with earth-return external to the conductor.⁶ Therefore, the expression for Z_{aa-g} can be written as

$$Z_{aa-g} = r_c + R_{aa-g} + jX_{aa-g} \quad (B-3)$$

where

$$R_{aa-g} = 4\omega P \text{ in nanoohms per centimeter}$$

$$X_{aa-g} = 2\omega \log_e \frac{4h_a}{d} + 4\omega Q \text{ in nanoohms per centimeter.}$$

The correction terms P and Q are expressed in equation form in Clarke's Volume I as

$$P = \frac{\pi}{8} - \frac{1}{3} \frac{k}{2} \cos \theta + \frac{k^2}{16} \cos 2\theta (0.6728 + \log_e \frac{2}{k}) \quad (B-4)$$

$$+ \frac{r^2}{16} \theta \sin 2\theta + \frac{k^3}{45} \cos 3\theta - \frac{\pi k^4}{1536} \cos 4\theta$$

and

$$Q = -0.0386 + \frac{1}{2} \log_e \frac{2}{k} + \frac{1}{3} \frac{1}{2} k \cos \theta - \frac{\pi k^2 \cos 2\theta}{64} + \frac{k^3 \cos 3\theta}{45 \cdot 2} - \frac{k^4 \theta \sin 4\theta}{384} - \frac{k^4 \cos 4\theta}{384} \left(\log_e \frac{2}{k} + 1.0895 \right).^6$$

(B-5)

For frequencies of 60 Hz or less, the correction terms P and Q can be given by

$$P = \frac{\pi}{8} + \Delta P \quad (B-6)$$

and

$$Q = -0.0386 + \frac{1}{2} \log_e \frac{2}{k} + \Delta Q. \quad (B-7)$$

Without appreciable error ΔP and ΔQ may be neglected, as was done by Clarke.⁶

The k used above is actually given as r in the original paper and is defined as

$$r = e'' \sqrt{\alpha} \quad (B-8)$$

$$\alpha = 4 \pi \lambda \omega \quad (B-9)$$

where

λ = conductivity of earth in nanoohms per centimeter cube

e'' = distance from conductor "a" to the image of conductor "b" in centimeters

$$\omega = 2 \pi f.$$

If the substitutions for α and ω are made, r becomes

$$r = 2 \pi e'' \sqrt{2 \lambda f}. \quad (B-10)$$

Figure (B-1) represents two conductors, "a" and "b", and their images. The angle θ in this figure represents the angle formed between a line drawn from conductor "a" to its image, and a line drawn from the same conductor to the image of conductor "b". This can be expressed as

$$\theta = \cos^{-1} \frac{h_a + h_b}{S_{ab}} \quad (B-11)$$

If $\theta = 0$, then $h_a = h_b$ and $e'' = S_{ab}$. Therefore, the new expression for r becomes

$$r = 4\pi h_a \sqrt{2\lambda f} \quad (B-12)$$

Remembering that r and k are one and the same, this expression becomes

$$k = 4\pi h_a \sqrt{2\lambda f} \quad (B-13)$$

Making the above substitutions for P and Q , the equation for Z_{aa-g} becomes

$$Z_{aa-g} = r_c + 4\omega \frac{(\pi)}{8} + j [2\omega \log_e \frac{4h_a}{d} + 4\omega(-0.0386 + \frac{1}{2} \log_e \frac{2}{4\pi h_a \sqrt{2\lambda f}})] \quad (B-14)$$

After combining terms, the self-impedance can be expressed as

$$Z_{aa-g} = r_c + 4\omega \frac{(\pi)}{8} + j2\omega (\log_e \frac{1}{\frac{d}{2} \sqrt{\lambda f}} (4.46) - 0.0772) \quad (B-15)$$

which shows the self-impedance to be independent of height. In order to represent Z_{aa-g} in ohms per 1000 feet, it is necessary to express "d" in inches by multiplying the centimeter value by 2.540, and replace λ with $10^{-11}/e$, where e is in ohms per meter cube. If the distance

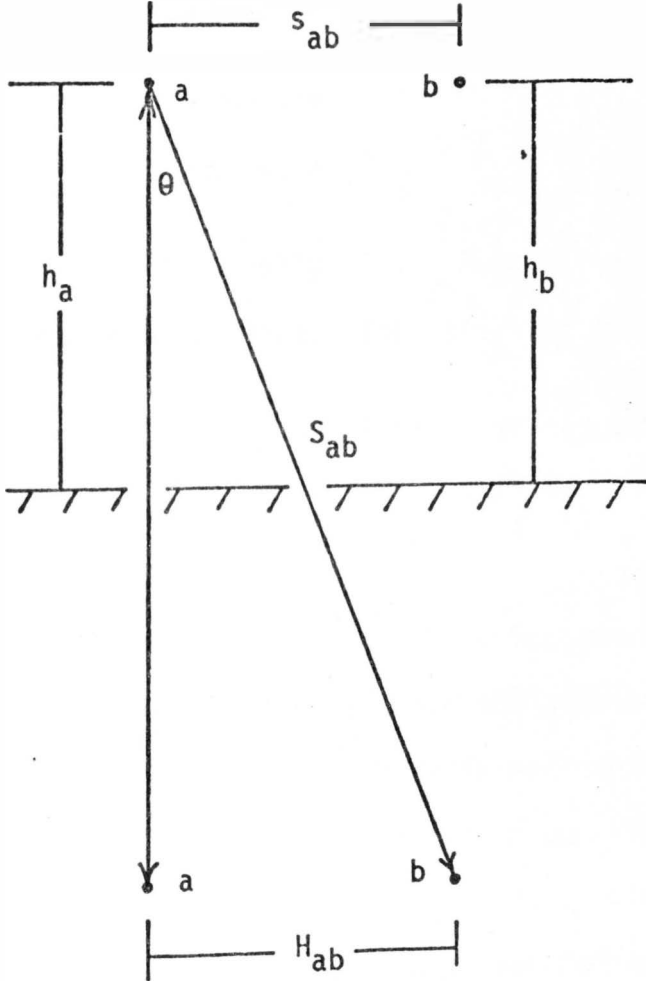

Figure (B-1)

TWO CONDUCTORS "a" AND "b" AND THEIR IMAGES

"d" is to be expressed in terms of a GMR_a , the following conversion can be used:

$$d \text{ (inches)} = 2 \times \text{radius (inches)} \quad (\text{B-16})$$

$$\text{radius (inches)} = R \text{ (ft)} \times \frac{12 \text{ inches}}{\text{foot}} \quad (\text{B-17})$$

$$\text{radius (inches)} = 12 R \quad (\text{B-18})$$

$$d \text{ (inches)} = 24 R \quad (\text{B-19})$$

where $R = GMR_a$ in feet. Finally, Z_{aa-g} must be multiplied by 3.048×10^4 centimeters per 1000 feet. The resulting equation becomes

$$Z_{aa-g} = (r_c + 4.788 (10^{-5}) \cdot 2\pi f) + j2\pi f [6.618 (10^{-4}) + 6.096 (10^{-5}) \log_e \frac{1}{24 GMR_a} \sqrt{\frac{e}{f}}] , \quad (\text{B-20})$$

which is the equation found in Ender's publication.

The expression for the mutual impedance with earth-return can be similarly obtained by substituting a different expression for e'' in equation (B-10), and then combining terms in equation (B-2). Using equation (B-11), the angle θ can be determined. Since in this case, e'' is equal to the distance between conductor "a" and the image of "b", k can be expressed as

$$k = 2\pi S_{ab} \sqrt{2\lambda f} . \quad (\text{B-21})$$

If this new value of k is substituted in equation (B-7), and equations (B-6) and (B-7) are substituted in equation (B-2) and simplified, a new expression for Z_{ab-g} in nanoohms per centimeter is obtained. By using

the same conversion as before, Z_{ab-g} can be expressed in ohms per 1000 feet. If this is done, Z_{ab-g} becomes

$$Z_{ab-g} = [4.788 (10^{-5}) 2\pi f] + j2\pi f [4.681 (10^{-4}) + 6.096 (10^{-5}) \log_e \frac{1}{s_{ab}} \sqrt{\frac{e}{f}}] \quad (B-22)$$

which, again, is the expression obtained by Ender.

According to the Bulletin of the Bureau of Standards, as well as other authors, the geometric spacing factor between two conductors is the distance between their centers.²³ In this case, s_{ab} is the distance from the center of the phase conductor to the center of the neutral wire. This is shown in figure (B-2). Using this geometric spacing factor, the expression for Z_{an-g} can be obtained by substituting $s_{ab} = \frac{D}{2}$ in equation (B-22). The result of this substitution is

$$Z_{an-g} = [4.788 (10^{-5}) \cdot 2\pi f] + j2\omega f [4.68 (10^{-4}) + 6.096 (10^{-5}) \log_e \frac{2}{D} \sqrt{\frac{e}{f}}], \quad (B-23)$$

which is the expression used by Ender to describe the mutual impedance with earth-return for a single-phase line.

The final formula Ender adapted for single-phase concentric neutral underground cable dealt with the self-impedance of the neutral with earth-return, Z_{nn-g} . According to Sunde and Clarke, an expression for Z_{nn-g} can be found using the equation

$$Z_{nn-g} = \frac{1}{N} [Z_{aa-g} + (N-1) Z_{an-g}] \quad (B-24)$$

where N is the number of wires comprising the concentric neutral.^{5,11}

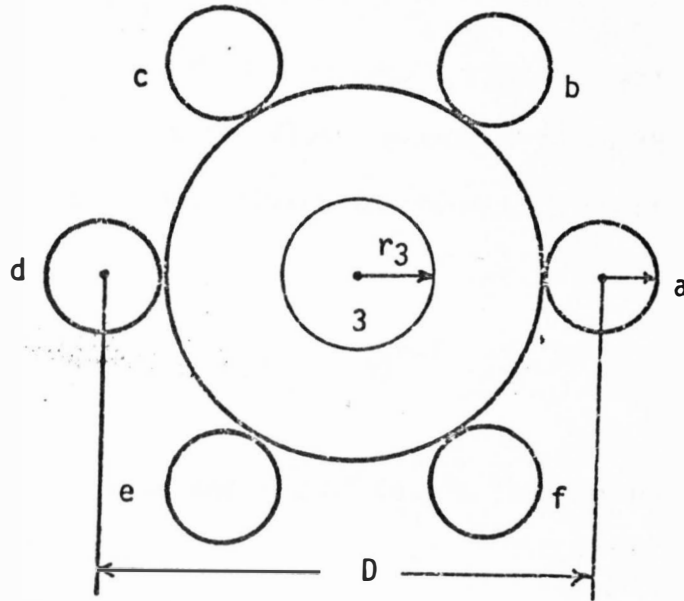

Figure (B-2)

CROSS SECTION OF AN UNDERGROUND CONDUCTOR

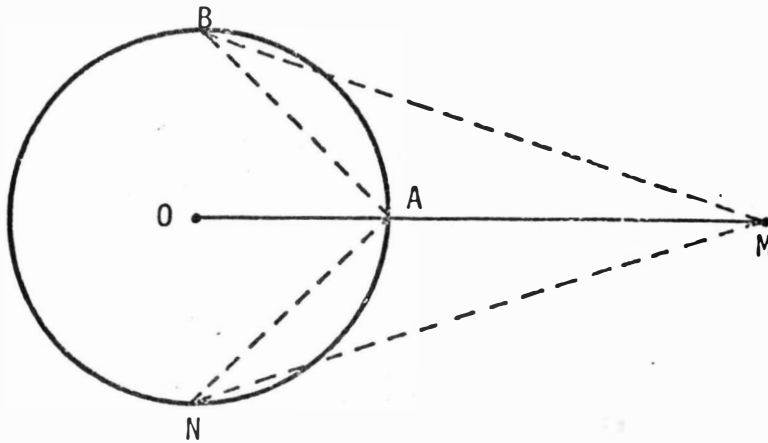

Figure (B-3)

CYLINDRICAL CONDUCTOR WITH
N POINTS AROUND ITS CIRCUMFERENCE

The same expressions developed for Z_{aa-g} and Z_{an-g} can be used in the formula above. However, the geometric spacing factor for Z_{an-g} must also take into account the flux linkages between the neutral wires. This can be done by multiplying the geometric spacing factor by a new factor, K_n , where

$$K_n = (n)^{\frac{1}{n-1}} \quad (B-25)$$

K_n can be derived with the aid of Cote's Theorem and figure (B-3).

Cote's theorem states that

If the circumference of a circle is divided into "n" equal parts by the points A,B,C,... and M be any point on the line through OA (inside or outside the circle), then putting $OM = X$

$$x^n - a^n = MA \cdot MB \cdot \dots \cdot MN \quad (B-26)$$

where

a = radius of circle points are located on

x = distance from O to M.

From figure (B-3), it is evident that $MA = x - a$. Substituting this expression in equation (B-26), the new expression becomes

$$x^n - a^n = (x - a) MB \cdot MN \quad (B-27)$$

which is the same as

$$\frac{x^n - a^n}{x - a} = MB \cdot MN. \quad (B-28)$$

Therefore,

$$a^0 x^{n-1} + a^1 x^{n-2} + a^2 x^{n-3} \dots a^{n-1} = MB \cdot MN. \quad (\text{B-29})$$

Now let the point "M" coincide with the point "A". Then the distance defined as MA becomes

$$MA = a$$

which means

$$x = a$$

and

$$OM = OA.$$

Substituting these new values in equation (B-29) yields

$$na^{n-1} = MB \cdot MN \quad (\text{B-30})$$

where

n = number of strands in the neutral.

Since this expression is representative for $n-1$ terms, the GMD of $n-1$ terms is

$$\text{GMD} = (MB \cdot MN)^{\frac{1}{n-1}}. \quad (\text{B-31})$$

This can also be expressed as

$$\text{GMD} = (na^{n-1})^{\frac{1}{n-1}} \quad (\text{B-32})$$

which is equal to

$$\text{GMD} = a(n)^{\frac{1}{n-1}}. \quad (\text{B-33})$$

The distance "a" is equal to $\frac{D}{2}$, as is shown in figure (B-3).

Therefore, the total geometric spacing factor can be split into two parts: "a" and $(n)^{\frac{1}{n-1}}$. The latter was defined by Ender as k_n . The total GMD was defined as $k_n \frac{D}{2}$. The expression for Z_{aa-g} is altered by the following changes: (1) the conductor resistance r_a becomes the neutral resistance r_n , and (2) the conductor, GMR_a becomes the neutral GMR_n . Inserting these changes into the original expression for Z_{aa-g} and Z_{an-g} and simplifying equation (B-24), yields

$$\begin{aligned}
 Z_{nn-g} = & \left[\frac{r_n}{N} + 4.788 (10^{-5}) \cdot 2\pi f \right] + j \frac{2\pi f}{N} [6.618 (10^{-4}) \\
 & + 6.096 (10^{-5}) \log_e \frac{1}{24 GMR_n} \sqrt{\frac{\rho}{f}} + (N-1) 4.681 (10^{-4}) \\
 & + (N-1) 6.096 (10^{-5}) \log_e \left(\frac{2}{k_n D} \sqrt{\frac{\rho}{f}} \right)]. \quad (B-34)
 \end{aligned}$$

This equation is the same as that proposed by R. C. Ender.

REFERENCES

1. Hollingsworth, D. T., "Underground Power Cables Past, Present and Future," Electronics and Power, Volume 15, September, 1969, pp. 314-319.
2. Muller, H. N., Jr., "Electrical Characteristics of Cables," Electrical Transmission and Distribution Reference Book, East Pittsburgh, Pennsylvania: Westinghouse Electric Corporation, 1964.
3. McNamee, P. H., Power Cables for Underground Distribution, Reynolds Metals Company, Minneapolis, Minnesota.
4. Correspondence: J. A. May to Eugene A. Christianson, August, 1971.
5. Carson, J. R., "Wave Propagation in Overhead Wires with Ground Returns," Bell System Technical Journal, Volume 5, November, 1926, pp. 539-554.
6. Clarke, Edith, Circuit Analysis of A-C Power Systems, Volume I, New York: John Wiley and Sons, Inc., 1943.
7. Clarke, Edith, Circuit Analysis of A-C Power Systems, Volume II, New York: John Wiley and Sons, Inc., 1950.
8. Carson, John R., "Ground Return Impedance: Underground Wire With Earth-Return," Bell Systems Technical Journal, Volume 8, 1929.
9. Gray, Marion C., "Mutual Impedance of Long Grounded Wires When the Conductivity of the Earth Varies Exponentially with Depth," Journal of Applied Physics, Volume 4, February, 1933.
10. Gray, Marion C., "Mutual Impedance of Grounded Wires Lying on the Surface of the Earth When the Conductivity Varies Exponentially with Depth," Journal of Applied Physics, Volume 5, January, 1934.
11. Sunde, Erling D., Earth Conduction Effects in Transmission Systems, New York: Dover Publications, Inc., 1968.
12. Ender, R. C., "Sequence Impedances of Underground Concentric Neutral Cable," The Line, McGraw-Edison Power Systems Division, 1971.
13. Van Wormer, F. C., "Approximate Impedance Calculations for Concentric Neutral Cables," Distribution, General Electric Company, Fourth Quarter, 1967.
14. Stone, D. L., "Mathematical Analysis of Direct Buried Rural Distribution Cable Impedance," IEEE Conference Record of 1971 Conference on Underground Distribution, September 27 - October 1, 1971, pp. 324-329.

15. Smith, D. R., Barger, J. V., "Impedance and Circulating Current Calculations for UD Multi-Wire Concentric Neutral Circuits," IEEE Conference Record of 1971 Conference on Underground Distribution, September 27 - October 1, 1971, pp. 130-138.
16. Rural Electrification Administration, "Underground Rural Distribution," REA Bulletin 61-3, June, 1967.
17. Stevenson, William D., Jr., Elements of Power System Analysis, New York: McGraw-Hill Book Company, 1962.
18. Woodruff, L. F., Principles of Electric Power Transmission, New York: John Wiley and Sons, Inc., 1956.
19. Beasley, William A., "A Discussion of Power Cable Shielding," Anaconda Wire and Cable Company, September, 1971.
20. Burnish, Steve, "Shielded Cable vs. Nonshielded Cable," Anaconda Cable Lore, Issue No. 30, February 25, 1971.
21. Rome Cable URD Technical Manual, Second Edition, Rome Cable, Rome, New York.
22. Halliday, D., Resnick, R., Physics Part II, New York: John Wiley and Sons, Inc., 1960.
23. Rosa, E. B., Grover, Frederick W., "Formulas and Tables for the Calculation of Mutual and Self-Inductance," Bulletin of the Bureau of Standards, Volume 8, 1912, p. 169.
24. Rosa, E. B., "Inductance of Linear Conductors," Bulletin of the Bureau of Standards, Volume 4, No. 2, 1907, p. 334-335.