



Aalborg Universitet

AALBORG UNIVERSITY
DENMARK

Integration and Coordination of Flexible Resources in Multi-energy Systems

Xi, Yufei; Fang, Jiakun; Chen, Zhe; Lund, Henrik; Thomsen, Søren Møller ; Dyrelund, Anders; Kristensen, Per G

Published in:
2020 IEEE PES General Meeting

Publication date:
2020

Document Version
Publisher's PDF, also known as Version of record

[Link to publication from Aalborg University](#)

Citation for published version (APA):
Xi, Y., Fang, J., Chen, Z., Lund, H., Thomsen, S. M., Dyrelund, A., & Kristensen, P. G. (Accepted/In press). Integration and Coordination of Flexible Resources in Multi-energy Systems. In *2020 IEEE PES General Meeting* [20PESGM0709] IEEE.

General rights

Copyright and moral rights for the publications made accessible in the public portal are retained by the authors and/or other copyright owners and it is a condition of accessing publications that users recognise and abide by the legal requirements associated with these rights.

- ? Users may download and print one copy of any publication from the public portal for the purpose of private study or research.
- ? You may not further distribute the material or use it for any profit-making activity or commercial gain
- ? You may freely distribute the URL identifying the publication in the public portal ?

Take down policy

If you believe that this document breaches copyright please contact us at vbn@aub.aau.dk providing details, and we will remove access to the work immediately and investigate your claim.

Integration and Coordination of Flexible Resources in Multi-energy Systems

Yufei Xi¹, Jiakun Fang¹, Zhe Chen¹, Henrik Lund², Søren Møller Thomsen³, Anders Dyrelund³ and Per G. Kristensen⁴

Dept. of Energy Technology, Aalborg University, Aalborg, Denmark¹

Dept. of Planning, Aalborg University, Aalborg, Denmark²

Energy Planning and Infrastructure, Rambøll, Copenhagen, Denmark³

Danish Gas Technology Centre, Copenhagen, Denmark⁴

yux@et.aau.dk, jfa@et.aau.dk, zch@et.aau.dk, lund@plan.aau.dk, SMT@ramboll.com, AD@ramboll.com, pgk@dgc.dk

Abstract—In a multi-energy system (MES), the integration of electricity, gas, district heating and cooling networks provides a promising opportunity to coordinate flexible resources (FRs). This paper proposes a multi-objective optimization model for coordinating FRs in different energy subsystems. The proposed scheduling model enables the MES to intelligently choose and utilize available FRs based on price signals of day-ahead markets, while allowing each energy subsystem to pursue its own maximal profit. An illustrative case study is analyzed to show the effectiveness of the proposed approach.

Keywords—Multi-energy system, flexible resources, multi-energy market, demand response, day-ahead scheduling.

NOMENCLATURE

Sets and indices

T	Set of hours of time horizon
Λ^m	Set of nodes directly connected to node m
Λ^{EPS}	Set of buses in the electric power system
Λ^{NGS}	Set of nodes in the natural gas system
Λ^{DHS}	Set of nodes in the district heating system
I^{CFP}	Set of coal-fired power (CFP) units at bus i
I^{CHP}	Set of combined heat and power (CHP) units at bus i
I^{WF}	Set of wind farms (WFs) at bus i
I^{P2G}	Set of power to gas (P2G) units at bus i
I^{EB}	Set of electric boilers (EBs) at bus i
I^{GB}	Set of gas boilers (GBs) at node i
I^{PL}	Set of power loads at bus i
I^{GL}	Set of gas loads at node i
I^{HL}	Set of heat loads at node i

Variables

$P_{i,t}^{\text{CHP}}$	Hour t power generation of CHP units at bus i (MW)
$P_{i,t}^{\text{CFP}}$	Hour t power generation of CFP units at bus i (MW)
$P_{i,t}^{\text{W}}$	Hour t power supply of wind units at bus i (MW)
$P_{i,t}^{\text{P2G}}$	Hour t power consumption of P2G units at bus i (MW)
$P_{i,t}^{\text{EB}}$	Hour t power consumption of EB units at bus i (MW)
$G_{i,t}^{\text{SN}}$	Hour t gas generation of gas source at node i (MW)

$G_{i,t}^{\text{GS,in/out}}$	Hour t gas input/output of gas storages at node i (MW)
$G_{i,t}^{\text{P2G}}$	Hour t gas generation of P2G units at node i (MW)
$G_{i,t}^{\text{CHP}}$	Hour t gas consumption of CHP units at node i (MW)
$G_{i,t}^{\text{GB}}$	Hour t gas consumption of GBs at node i (MW)
$G_{i,t}^{\text{LP,in/out}}$	Hour t gas input/output of linepacks at node i (MW)
$H_{i,t}^{\text{CHP}}$	Hour t heat generation of CHP units at node i (MW)
$H_{i,t}^{\text{HS,in/out}}$	Hour t heat input/output of heat storages at node i (MW)
$H_{i,t}^{\text{EB}}$	Hour t heat generation of EBs at node i (MW)
$H_{i,t}^{\text{GB}}$	Hour t heat generation of GBs at node i (MW)
$SOC_{i,t}^{\text{GS}}$	Hour t gas stock in gas storage i (MWh)
$SOC_{m,n,t}^{\text{LP}}$	Hour t gas stock in gas linepack m - n (MWh)
$SOC_{i,t}^{\text{HS}}$	Hour t heat stock in heat storage i (MWh)
$\delta_{n,t}$	Hour t phase angle of bus n (rad)
$ED_{i,t}$	Hour t DR-improved power load at bus i (MW)
$PL_{i,t}^{\text{shift}}$	Hour t shifted load at bus i (MW)
$HD_{i,t}$	Hour t actual thermal demand at node i (MW)
$\tau_{i,t}^{\text{s,out}}$	Hour t outlet temperature of supply pipe i (°C)
$\tau_{i,t}^{\text{r,in/out}}$	Hour t inlet/outlet temperature of return pipe i (°C)

I. INTRODUCTION

Faced with climate change and fossil resource reduction, the global energy mix is experiencing an important transition to sustainable energy supply [1]. Meanwhile, with the development of energy conversion technologies such as combined heat and power (CHP), power to gas (P2G), electric boilers (EBs), heat pumps (HPs), etc., integration across energy sectors of the MES is an efficient measure to provide better energy services [2].

However, with the increasing penetration of renewable energy, higher flexibility and safety requirements have become a challenge for operating MESs. As Lund et al. mentioned in the studies of smart energy systems, the utilization of FRs including flexible energy equipment and integrated system

operation to increase system flexibility has been widely accepted [3]. Many researches has considered the specific FRs to increase flexibility of the related energy system. Reference [4] considers demand response (DR), bulk storages and plug-in electric vehicles, and proposes an integrated stochastic market model of the electric power system (EPS) and the parking lot. In [5], an electricity-natural gas day-ahead scheduling model with DR for flexible ramp deployment is proposed, which shows that DR can reduce the dependence of the EPS on the NGS. A bi-level optimization model of the combined heat and electricity system is given in [6], where the flexible demand is achieved by the electric heating operation. In addition, an integrated model with various energy storages for optimizing energy distribution of the local building is built in [7]. As it is demonstrated in these researches, the utilization of FRs can offer great flexibility to MESs.

In most existing quantitative works, FRs are applied separately to each single energy carrier system or mainly investigated in a single energy system, while the integration and coordination of FRs are rarely mentioned by using the integration of energy networks and information exchange of energy markets. In [8], based on the “energy hub” framework, an optimization model of the MES with P2G function is formulated, and a game-theory method is proposed to attain the market equilibrium. In [9], a bi-level approach is presented to model the behavior of multi-energy players who trades more than one energy carrier and refers to signal prices in the energy market. Therefore, this paper uses FRs including gas and heat storages, DR and multiple options of energy supply, proposes a multi-objective optimization problem to jointly operate the EPS, the NGS and the district heating system (DHS), and coordinates FRs across multi-energy sectors to integrate more renewable energy. It is worth mentioning that in warm climate district cooling and chilled water storages are vital for the demand response and for reducing the cooling peak, moreover there is an interesting symbiosis between district heating and district cooling, as heat pumps can be used successfully for both purposes in particular in combination with ground source cooling. However, we only focus on the heating in order to demonstrate the important interaction among electricity, natural gas and heat in this paper.

The remainder of the paper is organized as follows. Section II describes the structure of a typical Danish MES with FRs and formulates a multi-objective optimization model. Section III presents and analyzes a case study. Section IV is the conclusion.

II. MODEL FORMULATION

A. Description of the MES with FRs

A MES model including the NGS, the DHS and the EPS is considered in this paper. The energy supply options in this model is an extension and improvement of Aalborg, Denmark, and each subsystem (NGS, DHS and EPS) has its own operator to control the energy distribution and trading.

The interactions among different energy systems are shown in Fig. 1. The NGS includes gas sources, gas storages, gas demands, P2G units and the gas network. The EPS includes CFP units, wind farms, electricity demands and the electricity network. The DHS includes CHP units, EBs, gas boilers (GBs),

heat storages, heat demands and the heat network. Here we assume that P2G units are controlled by the NGS operator and consume electricity to supply gas. CHP units are controlled by the DHS operator and convert gas to electricity and heat. The power generation of any CHP unit is determined by the heat generation. Meanwhile, EBs and GBs supply heat for the DHS by consuming electricity and gas respectively.

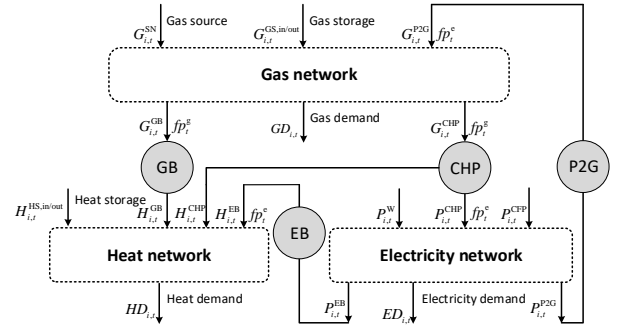

Fig. 1 Framework of the MES with FRs

In this multi-energy market, the NGS acts as a pure provider if P2G units are not considered, while the DHS is a pure consumer, which purchases gas from the NGS or electricity from the EPS to supply heat. The EPS acts as a prosumer. On the one hand, it purchases electricity from CHP plants. On the other hand, it may sell electricity to run EBs for the DHS. When there is a surplus of wind power or a low electricity price, the EPS may sell electricity to run P2G units for the NGS. Therefore, in addition to energy trading decisions among different subsystems, the action (energy allocation and energy units) of any operator will affect the decision of the other operators.

In this MES, FRs are available on the supply side of the DHS, the demand side of the EPS and integration of energy networks. Furthermore, on the supply side of the DHS, the DHS operator has multiple options of heat generation. On the demand side of the EPS, DR can change consumption patterns of electricity consumers. In other words, besides storage devices of each subsystem, each subsystem operator in the multi-energy market can choose and utilize these FRs intelligently according to the price signals of each energy carrier, and integrate more renewable energy while pursuing its own economic benefits.

B. Day-ahead Scheduling Model for coordination of FRs

In this section, we assume that there is perfect information communication among subsystems and each subsystem operator pursues to maximize its own social welfare (SW). Thus, based on prices signals of day-ahead markets, a multi-objective day-ahead scheduling model is formulated to search for a Pareto optimal solution for the MES [10]. For the EPS, the optimization problem is expressed as:

$$\max \sum_{t=1}^T \left(\sum_{i=1}^{I^{PL}} u^{ED} ED_{i,t} + \sum_{i=1}^{I^{EB}} fp_t^e P_{i,t}^{EB} + \sum_{i=1}^{I^{P2G}} fp_t^e P_{i,t}^{P2G} - \sum_{i=1}^{I^{CFP}} c_i^{CFP} P_{i,t}^{CFP} - \sum_{i=1}^{I^{CHP}} fp_t^e P_{i,t}^{CHP} \right) \quad (1)$$

Subject to:

$$\sum_{i=1}^{I^{CHP}} P_{i,t}^{CHP} + \sum_{i=1}^{I^{CFP}} P_{i,t}^{CFP} + \sum_{i=1}^{I^{WF}} P_{i,t}^W - \sum_{i=1}^{I^{P2G}} P_{i,t}^{P2G} - \sum_{i=1}^{I^{EB}} P_{i,t}^{EB} - \sum_{i=1}^{I^{PL}} ED_{i,t} = \sum_{n \in \Lambda^m} B_{mn} (\delta_{m,t} - \delta_{n,t}), \forall t \in T, \forall m \in \Lambda^{EPS} \quad (2)$$

$$P_i^{CFP,\min} \leq P_{i,t}^{CFP} \leq P_i^{CFP,\max}, \forall i \in I^{CFP}, \forall t \in T \quad (3)$$

$$RP_i^{CFP,\min} \leq P_{i,t}^{CFP} - P_{i,t-1}^{CFP} \leq RP_i^{CFP,\max}, \forall i \in I^{CFP}, \forall t \in T \quad (4)$$

$$-P_{mn}^{TL} \leq B_{mn} (\delta_{m,t} - \delta_{n,t}) \leq P_{mn}^{TL}, \forall m, n \in \Lambda^{EPS}, \forall t \in T \quad (5)$$

$$0 \leq P_{i,t}^W \leq P_{i,t}^{W,av}, \forall i \in I^{WF}, \forall t \in T \quad (6)$$

$$ED_{i,t} = PL_{i,t} - PL_{i,t}^{shift}, \forall i \in I^{PL}, \forall t \in T \quad (7)$$

$$|PL_{i,t}^{shift}| \leq \lambda^{shift} \cdot PL_{i,t}, \forall i \in I^{PL}, \forall t \in T \quad (8)$$

$$\sum_{i=1}^T PL_{i,t}^{shift} = 0, \forall i \in I^{PL} \quad (9)$$

$$\left| (PL_{i,t} - PL_{i,t}^{shift}) - (PL_{i,t-1} - PL_{i,t-1}^{shift}) \right| \leq \Delta PL, \forall i \in I^{PL}, \forall t \in T \quad (10)$$

For the NGS, the optimization problem is expressed as:

$$\max \sum_{i=1}^T \left(\sum_{i=1}^{I^{GL}} u^{GD} GD_{i,t} + \sum_{i=1}^{I^{CHP}} fp_i^s G_{i,t}^{CHP} + \sum_{i=1}^{I^{GB}} fp_i^s G_{i,t}^{GB} - \sum_{i=1}^{I^{SN}} c_i^{SN} G_{i,t}^{SN} - \sum_{i=1}^{I^{P2G}} fp_i^e P_{i,t}^{P2G} - \sum_{i=1}^{I^{GS}} (c_i^{GS,in} G_{i,t}^{GS,in} + c_i^{GS,out} G_{i,t}^{GS,out}) \right) \quad (11)$$

Subject to:

$$\sum_{i=1}^{I^{SN}} G_{i,t}^{SN} + \sum_{i=1}^{I^{GS}} (G_{i,t}^{GS,out} - G_{i,t}^{GS,in}) + \sum_{i=1}^{I^{P2G}} G_{i,t}^{P2G} - \sum_{i=1}^{I^{CHP}} G_{i,t}^{CHP} - \sum_{i=1}^{I^{GB}} G_{i,t}^{GB} + \sum_{i=1}^{I^{LP}} (G_{i,t}^{LP,out} - G_{i,t}^{LP,in}) - \sum_{i=1}^{I^{GL}} GD_{i,t} = \sum_{n \in \Lambda^m} G_{mn,t}, \forall t \in T, \forall m \in \Lambda^{NGS} \quad (12)$$

$$G_{mn,t}^2 = \frac{p_m^2 - p_{n,t}^2}{Z_{mn}}, \forall t \in T, \forall m, n \in \Lambda^{NGS} \quad (13)$$

$$G_{i,t}^{P2G} = \eta_i^{P2G} P_{i,t}^{P2G}, \forall i \in I^{P2G}, \forall t \in T \quad (14)$$

$$G_i^{P2G,\min} \leq G_{i,t}^{P2G} \leq G_i^{P2G,\max}, \forall i \in I^{P2G}, \forall t \in T \quad (15)$$

$$G_i^{SN,\min} \leq G_{i,t}^{SN} \leq G_i^{SN,\max}, \forall i \in I^{SN}, \forall t \in T \quad (16)$$

$$0 \leq G_{i,t}^{GS,in/out} \leq G_i^{GS,in/out,\max}, \forall i \in I^{GS}, \forall t \in T \quad (17)$$

$$SOC_{i,t}^{GS} - SOC_{i,t-1}^{GS} = (G_{i,t}^{GS,in} - G_{i,t}^{GS,out}) \Delta t, \forall i \in I^{GS}, \forall t \in T \quad (18)$$

$$SOC_i^{GS,\min} \leq SOC_{i,t}^{GS} \leq SOC_i^{GS,\max}, \forall i \in I^{GS}, \forall t \in T \quad (19)$$

$$SOC_{i,t_0}^{GS} = SOC_{i,t}^{GS}, \forall i \in I^{GS}, \forall t \in T \quad (20)$$

$$0 \leq G_{mn,t}^{LP,in/out} \leq G_{mn,t}^{LP,in/out,\max}, \forall m, n \in \Lambda^{NGS}, \forall t \in T \quad (21)$$

$$SOC_{mn,t}^{LP} - SOC_{mn,t-1}^{LP} = (G_{mn,t}^{LP,in} - G_{mn,t}^{LP,out}) \Delta t, \forall m, n \in \Lambda^{NGS}, \forall t \in T \quad (22)$$

$$SOC_{mn}^{LP,\min} \leq SOC_{mn,t}^{LP} \leq SOC_{mn}^{LP,\max}, \forall m, n \in \Lambda^{NGS}, \forall t \in T \quad (23)$$

$$SOC_{mn,t_0}^{LP} = SOC_{mn,t}^{LP}, \forall m, n \in \Lambda^{NGS}, \forall t \in T \quad (24)$$

$$-G_{mn}^{GP} \leq G_{mn,t} \leq G_{mn}^{GP}, \forall t \in T, \forall m, n \in \Lambda^{NGS} \quad (25)$$

For the DHS, the optimization problem is expressed as:

$$\max \sum_{i=1}^T \left(\sum_{i=1}^{I^{HL}} u^{HD} HD_{i,t} + \sum_{i=1}^{I^{CHP}} fp_i^c P_{i,t}^{CHP} - \sum_{i=1}^{I^{CHP}} fp_i^s G_{i,t}^{CHP} - \sum_{i=1}^{I^{GB}} fp_i^s G_{i,t}^{GB} - \sum_{i=1}^{I^{EB}} fp_i^c P_{i,t}^{EB} - \sum_{i=1}^{I^{HS}} (c_i^{HS,in} H_{i,t}^{HS,in} + c_i^{HS,out} H_{i,t}^{HS,out}) \right) \quad (26)$$

Subject to:

$$\sum_{i=1}^{I^{CHP}} H_{i,t}^{CHP} + \sum_{i=1}^{I^{HS}} (H_{i,t}^{HS,out} - H_{i,t}^{HS,in}) + \sum_{i=1}^{I^{EB}} H_{i,t}^{EB} + \sum_{i=1}^{I^{GS}} H_{i,t}^{GS} - \sum_{i=1}^{I^{HL}} HD_{i,t} = \sum_{n \in \Lambda^m} H_{mn,t}, \forall t \in T, \forall m \in \Lambda^{DHS} \quad (27)$$

$$P_{i,t}^{CHP} = r_i^{CHP} \cdot H_{i,t}^{CHP}, \forall i \in I^{CHP}, \forall t \in T \quad (28)$$

$$P_{i,t}^{CHP} = \eta_i^{CHP} \cdot G_{i,t}^{CHP}, \forall i \in I^{CHP}, \forall t \in T \quad (29)$$

$$H_i^{CHP,\min} \leq H_{i,t}^{CHP} \leq H_i^{CHP,\max}, \forall i \in I^{CHP}, \forall t \in T \quad (30)$$

$$RH_i^{CHP,\min} \leq H_{i,t}^{CHP} - H_{i,t-1}^{CHP} \leq RH_i^{CHP,\max}, \forall i \in I^{CHP}, \forall t \in T \quad (31)$$

$$H_{i,t}^{EB} = COP_i \cdot P_{i,t}^{EB}, \forall i \in I^{EB}, \forall t \in T \quad (32)$$

$$H_i^{EB,\min} \leq H_{i,t}^{EB} \leq H_i^{EB,\max}, \forall i \in I^{EB}, \forall t \in T \quad (33)$$

$$H_{i,t}^{GB} = \eta_i^{GB} \cdot G_{i,t}^{GB}, \forall i \in I^{GB}, \forall t \in T \quad (34)$$

$$H_i^{GB,\min} \leq H_{i,t}^{GB} \leq H_i^{GB,\max}, \forall i \in I^{GB}, \forall t \in T \quad (35)$$

$$0 \leq H_{i,t}^{HS,in/out} \leq H_i^{HS,in/out,\max}, \forall i \in I^{HS}, \forall t \in T \quad (36)$$

$$SOC_{i,t}^{HS} - \sigma SOC_{i,t-1}^{HS} = (H_{i,t}^{HS,in} \eta_i^{HS,in} - H_{i,t}^{HS,out} / \eta_i^{HS,out}) \Delta t, \forall i \in I^{HS}, \forall t \in T \quad (37)$$

$$SOC_i^{HS,\min} \leq SOC_{i,t}^{HS} \leq SOC_i^{HS,\max}, \forall i \in I^{HS}, \forall t \in T \quad (38)$$

$$SOC_{i,t_0}^{HS} = SOC_{i,t}^{HS}, \forall i \in I^{HS}, \forall t \in T \quad (39)$$

$$-H_{mn}^{HP} \leq H_{mn,t} \leq H_{mn}^{HP}, \forall t \in T, \forall m, n \in \Lambda^{DHS} \quad (40)$$

$$\alpha_i = x_i / v \cdot \left\{ 1 + hh_1 / \left[\omega^2 + (h_1 + h_2)^2 \right] \right\} \quad (41)$$

$$\varphi_i = \exp \left\{ hx_i / v \cdot \left\{ 1 - h_1 (h_1 + h_2) / \left[\omega^2 + (h_1 + h_2)^2 \right] \right\} \right\} \quad (42)$$

$$\begin{cases} h = k^{wp} L^{in} / Ac \rho \\ h_1 = k^{wp} L^{in} / A^p c^p \rho^p \\ h_2 = kL^{ex} / A^p c^p \rho^p \end{cases} \quad (43)$$

$$HD_{i,t} = c \cdot m_i \cdot (\tau_{i,t}^{s,in} - \tau_{i,t}^{r,out}), \forall i \in I^{HL}, \forall t \in T \quad (44)$$

$$\begin{cases} \tau_{i,t}^{s,out} = \varphi_i \cdot \tau_{i,t-\alpha_i}^{s,in} + \tau_{i,t}^a \cdot (1 - \varphi_i) \\ HL_{i,t} = c \cdot m_i \cdot (\tau_{i,t}^{s,out} - \tau_{i,t}^{r,in}) \\ \tau_{i,t}^{r,out} = \varphi_i \cdot \tau_{i,t-\alpha_i}^{r,in} + \tau_{i,t}^a \cdot (1 - \varphi_i) \end{cases}, \forall i \in I^{HL}, \forall t \in T \quad (45)$$

The three optimization objectives (1), (11), (26) represent the day-ahead scheduling for maximizing SW of the EPS, the NGS and the DHS, respectively. Each objective function mainly has two components including the utility of energy consumption and the operational cost of energy facilities.

Different from the instantaneous transmission of electricity, the heat transmission is not instant. The heat is transferred by the water fluid, resulting in the temperature variation of the fluid and pipe wall to be dynamic variables in time and space.

In order to simplify calculations, we assume that each secondary network of the DHS is a heat exchanger. Meanwhile, the hot water flows from the inlet to the outlet of each pipe and the water flow rate keeps constant. Based on the function method in references [11], we use two parameters (lag time α_i and relative attenuation degree ϕ_i) to describe the temperature change along the heat pipeline as shown in Equation (41) and (42), where the related parameters are defined by Equation (43). More specifically, the lag time means the time it takes for the water temperature to change from inlet temperature to the outlet temperature, while the relative attenuation degree reflects the temperature drop along the heating pipe, causing heat loss in this process. Thus, according to the curve of hourly heat loads predicted by the day-ahead energy market, we can calculate the actual heat demands by Equations (44) and (45).

We note that, there is a non-convex Equation (13) in the DHS optimization. If the variation of the gas in the pipeline is limited in a narrow range, Equation (13) can be reformulated as a linear and convex equation as shown in [12]. Thus, for a linear and convex multi-objective optimization problem, the most common approach is to replace the original problem by KKT conditions [13]. We search for an optimal equilibrium among all subsystems, where each energy subsystem can both operate independently and equally, and coordinate multiple FRs to obtain the maximum SW of MES. In this paper, the optimization model is solved using under GAMS.

III. CASE STUDY

A. Description of the Test System

In this section, we assume that the MES is small enough and its energy demand is not enough to impact energy prices of the upper multi-energy markets. An illustrative test is simulated to validate the proposed model, which includes a 4-node NGS with a gas source, a P2G unit and a gas storage, an 8-node DHS with a CHP unit, a heat storage, a GB and an EB, and a 4-bus EPS with a wind farm and a CFP unit. The topology of this test system is shown in Fig. 2. We choose January 1, 2017 of Denmark as a typical day. The hourly electricity, gas and heat loads, the wind power profiles and energy prices as shown in Fig. 3 are included in the test. The related technology, system and market data are obtained from Energinet.dk and Danish Energy Agency [14], [15]. They are rationally scaled to fit this case study.

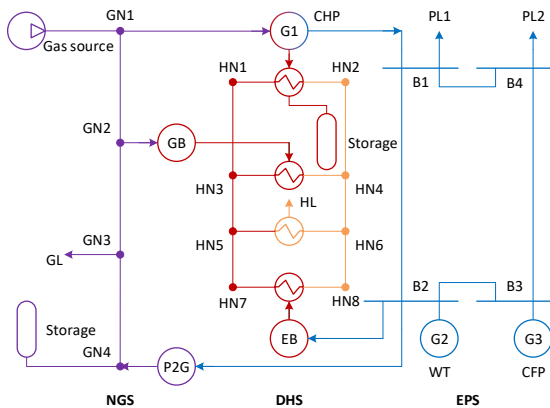

Fig. 2 Topology diagram of the test MES

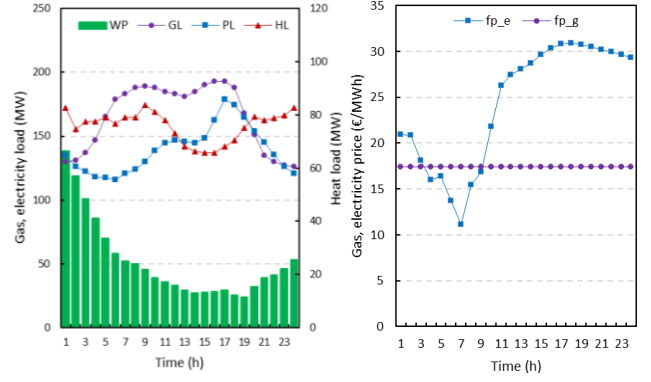

Fig. 3 Profiles of test data

B. Simulation Results

For a time horizon of 24 hours, Fig. 4 (a)-(c) show the optimal scheduling strategy of the MES in the scenario where $\lambda^{\text{shift}}=20\%$. It should be noted that the total electricity/gas consumption consists of the electricity/gas demand and the electricity/gas consumed by interfacing conversion devices. In addition, the heat loss caused by the heat transfer has been considered in Equations (40)-(44).

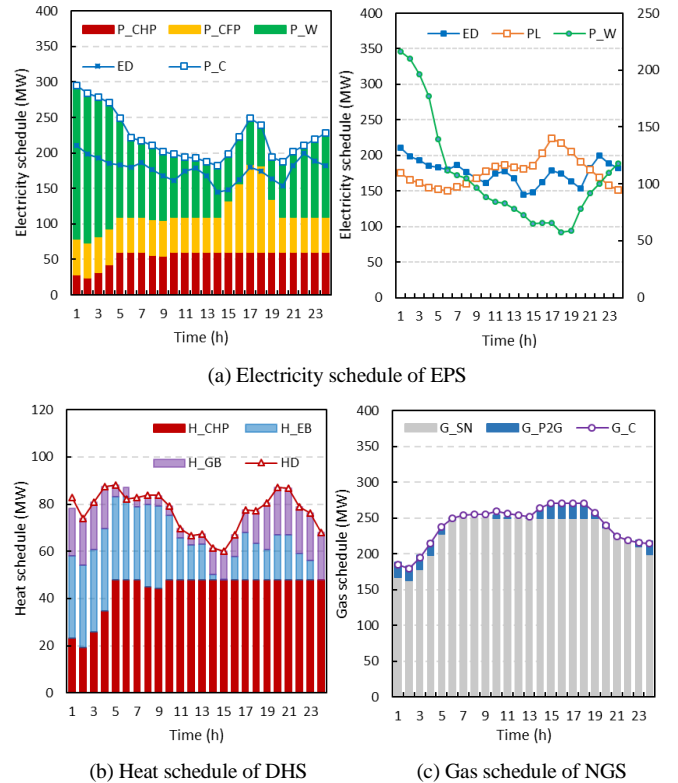
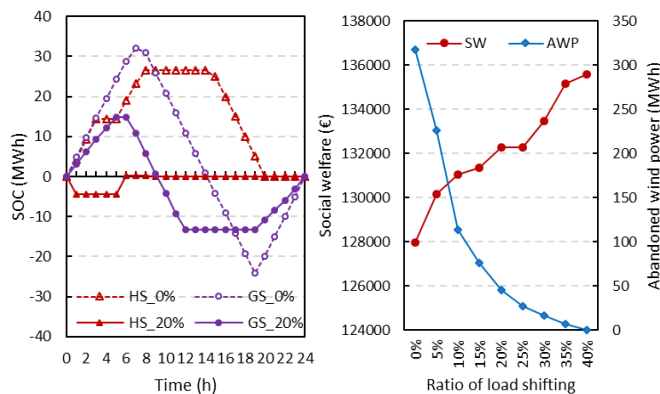

Fig. 4 Optimal schedule of sources in the MES

During period 1h-9h, the MES is in a high-wind and low-electricity price scenario. Since the EPS is at the valley of electricity loads, the aggregator encourages DR users to use more electricity, which causes an increase of the electricity demand, while the DHS and the NGS prefer to use P2G units and EBs to supply heat and gas because of the cheap electricity price. In addition, heat storages and gas storages can store the cheap energy for emergency needs. All these behaviors can

ensure that the wind power is accommodated as much as possible. After period 10h, the MES is in a low-wind scenario and the electricity price gradually rises to a peak 30.93€/MWh. During period 13h-19h, since the EPS is at the peak of electricity loads, the aggregator adjusts DR users to decrease the electricity demand. Meanwhile, the NGS at the peak of gas loads has enough electricity to run P2G units to assist in gas supply, and the DHS at the valley of heat loads prefer GBs and CHP units to supply heat.

In order to explore the impact of the amount of load shifting in the electricity DR on the energy storages of other subsystems, Fig. 5 (a) shows the hourly SOC of the gas storage and the heat storage in two scenarios ($\lambda^{\text{shift}}=0$ and $\lambda^{\text{shift}}=20\%$). We can see that, compared with the case of $\lambda^{\text{shift}}=0$, the used capacity of the gas storage and the heat storage are both reduced in the case of $\lambda^{\text{shift}}=20\%$, which may result in a reduction in the investment of storage capacity. Since the capacity limits of P2G units, abandoned wind power (AWP) still exists. Fig. 5 (b) shows SW and AWP of the MES in different scenarios of λ^{shift} . We can see that as the ratio of load shifting λ^{shift} is higher in the MES, SW is higher and wind power curtailment is lower. However, a completely smooth load profile is obviously impractical. Here, this paper only shows the results for $\lambda^{\text{shift}} \leq 40\%$.



(a) SOC of storages in $\lambda^{\text{shift}}=0$ and 20% (b) SW and AWP in different λ^{shift}

Fig. 5 Comparison of results in different λ^{shift} scenarios

In the proposed optimization model, the simulation results show that FRs are no longer limited to their own energy subsystems but integrated by energy networks and energy conversion devices. Subsystem operators of the MES make actions to coordinate these FRs by the price signals of the day-ahead markets, so that the MES will have higher SW and integrate more renewable energy.

IV. CONCLUSION

This work focuses on the integration of FRs across different energy systems. Collecting energy price signals in the day-ahead market and using energy conversion technologies enable the MES to intelligently choose and utilize these FRs. This paper develops a multi-objective day-ahead scheduling model for coordinating FRs and optimizing energy distribution. The

improved MES based on the energy supply options in Aalborg, Denmark is taken as the case study. The simulation results indicate that the coordination of FRs can offer great flexibility to the MES. Additionally, we can find that as an important FR of the electricity demand side, DR has significant benefits in improving social welfare and reducing wind power curtailment.

ACKNOWLEDGMENT

The authors are very grateful for the support of the EUDP Project ‘Sustainable Energy Market Integration (SEMI)’ (EUDP17-I: 12554) and China Scholarship Council.

REFERENCES

- [1] H. Lund, A. N. Andersen, P. A. Østergaard, B. V. Mathiesen and D. Connolly, “From electricity smart grids to smart energy systems - a market operation based approach and understanding,” *Energy*, vol. 42, no. 1, pp. 96–102, Jun. 2012.
- [2] H. Lund, P. A. Østergaard, D. Connolly and B. V. Mathiesen, “Smart energy and smart energy systems,” *Energy*, vol. 137, no. 1, pp. 556–565, Oct. 2017.
- [3] H. Lund, *Renewable Energy Systems: A smart energy systems approach to the choice and modeling of 100% renewable solutions*, Academic Press, 2014, pp. 80–86.
- [4] E. Heydarian-Forushani, M. E. H. Golshan, M. Shafie-khah and P. Siano, “Optimal operation of emerging flexible resources considering sub-hourly flexible ramp product,” *IEEE Trans. Sustain. Energy*, vol. 9, no. 2, pp. 916–929, Apr. 2018.
- [5] X. Zhang, L. Che, M. Shahidehpour, A. Alabdulwahab and A. Abusorrah, “Electricity-natural gas operation planning with hourly demand response for deployment of flexible ramp,” *IEEE Trans. Energy*, vol. 7, no. 3, pp. 996–1004, Jul. 2016.
- [6] C. Shao, Y. Ding, J. Wang and Y. Song, “Modeling and integration of flexible demand in heat and electricity integrated energy system,” *IEEE Trans. Sustain. Energy*, vol. 9, no. 1, pp. 361–370, Jul. 2017.
- [7] Y. Zhang, P. E. Campana, Y. Yang, B. Stridh, A. Lundblad and J. Yan, “Energy flexibility from the consumer: Integrating local electricity and heat supplies in a building,” *Applied Energy*, vol. 223, no. 1, pp. 430–442, Aug. 2018.
- [8] Y. Wang, J. Zhao, F. Wen and Y. Xue, “Market equilibrium of multi-energy system with power-to-gas functions,” *Automation of Electric Power Systems*, vol. 39, no. 21, pp. 1–10, Oct. 2015.
- [9] M. Y. Damavandi, S. Bahramara, M. P. Moghaddam, M. Haghifam, M. Shafie-khah and J. P. S. Catalão, “Bi-level approach for modeling multi-energy players’ behavior in a multi-energy system,” 2015 IEEE Eindhoven PowerTech, Sep. 2015.
- [10] C. L. Hwang and A. S. M. Masud, *Multiple objective decision making-methods and applications: a state-of-the-art survey*, Springer Science & Business Media, Dec. 2012, pp. 21–97.
- [11] P. Jie, Z. Tian, S. Yuan and N. Zhu, “Modeling the dynamic characteristics of a district heating network,” *Energy*, vol. 39, no. 1, pp. 126–134, Mar. 2012.
- [12] J. Fang, Q. Zeng, Z. Chen and J. Wen, “Dynamic optimal energy flow in the integrated natural gas and electrical power systems,” *IEEE Trans. Sustain. Energy*, vol. 9, no. 1, pp. 188–197, Jan. 2018.
- [13] C. Ruiz and A. J. Conejo, “Pool strategy of a producer with endogenous formation of locational marginal prices,” *IEEE Trans. Power Syst.*, vol. 24, no. 4, pp. 1855–1866, Nov. 2009.
- [14] Energinet.dk, “Market data portal” [Online]. Available: http://osp.energinet.dk/_layouts/Markedsdata/framework/integrations/markedatemplate.aspx.
- [15] Danish Energy Agency, “technology Catalogs” [Online]. Available: <https://ens.dk/service/fremskrivninger-analyser-modeller/teknologikataloger>