

7-2020

Heat and Mass Transfer in Parboiled Rice during Heating with 915 MHz Microwave Energy and Impacts on Milled Rice Properties

Deandrae L.W. Smith
University of Arkansas, Fayetteville

Follow this and additional works at: <https://scholarworks.uark.edu/etd>



Part of the [Food Processing Commons](#)

Citation

Smith, D. L. (2020). Heat and Mass Transfer in Parboiled Rice during Heating with 915 MHz Microwave Energy and Impacts on Milled Rice Properties. *Theses and Dissertations* Retrieved from <https://scholarworks.uark.edu/etd/3814>

This Dissertation is brought to you for free and open access by ScholarWorks@UARK. It has been accepted for inclusion in Theses and Dissertations by an authorized administrator of ScholarWorks@UARK. For more information, please contact ccmiddle@uark.edu.

Heat and Mass Transfer in Parboiled Rice during Heating with 915 MHz Microwave Energy and
Impacts on Milled Rice Properties

A dissertation submitted in partial fulfillment
of the requirements for the degree of
Doctor of Philosophy in Food Science

by

Deandrae L. W. Smith
University of Arkansas
Bachelor of Science in Biological Engineering, 2014
University of Arkansas
Master of Science in Food Science, 2017

July 2020
University of Arkansas

This dissertation is approved for recommendation to the Graduate Council.

Griffiths Atungulu PhD
Dissertation Director

Sammy Sadaka PhD
Committee Member

Terry Siebenmorgen PhD
Committee Member

Andy Mauromoustakos PhD
Committee Member

Ruben Morawicki PhD
Committee Member

ABSTRACT

Microwave (MW) heating offers an energy-efficient, fast method to dry high moisture content (MC) parboiled rice to safe storage MC. However, there is limited research that describes the fundamentals of heat and mass transport in rice kernels exposed to MW energy at 915 MHz, the most promising heating frequency for industrialized processing. This information is vital to explain the implications of MW technology on dried rice quality. The overall objective of this study was to develop a microwave heating technology that can sufficiently dry high MC parboiled rough rice kernels in one pass using a 915-MHz industrial microwave system. An industrial type MW system operating at 915 MHz frequency was used to dry high MC long-grain parboiled rough rice samples that were harvested at initial MC of 23% to 24% wet basis (w.b). Long grain rough rice samples were soaked in a lab-scale hot water bath set to soaking temperatures of 71 °C, 73 °C and 76 °C for 3 hours. After soaking, the wet rough rice was steamed in a lab-scale autoclave set to a temperature of 113 °C and a corresponding pressure value of 67 kPa for 5, 10 and 15 minutes (mins). The MW drying was accomplished at MW specific powers that ranged from 0.37 to 8.77 kW. [kg-DM]⁻¹ (power per unit dry matter mass of the grain). During drying, fiber optic sensors were placed within the rice bed to collect real-time parboiled rough rice surface temperature. Results indicate that rough rice should be soaked at temperatures slightly below that of the onset gelatinization temperature of that rice cultivar and steamed for 10 min for optimal physiochemical and milling properties prior to drying by MW. Parboiled rough rice at initial MC of 35.88% reduced to a FMC of 13.48% after being treated with MW power level of 2 kW and drying duration of 31.5 min (MW specific energy of 3780 kJ.[kg-grain]⁻¹) and at a low specific power of 2.92 kW.[kg-DM]⁻¹. Increased MW specific power has a positive effect on parboiled rough rice MC reduction but negatively effects the rice milling characteristics. The head rice yield (HRY)

obtained from the treatment was dependent on the specific energy input and reduced at higher specific energies. The drying rate was highest during the beginning of drying then slowed down during the end and can be divided into 2 periods, a first falling rate period (1.5 min to 7.5 min), and the second falling rate period (7.5 min to 31.5 min). Of the Page, Newton, Logarithmic, and Henderson & Pabis semi-empirical drying models, the logarithmic model best represented the MW drying behavior of parboiled rough rice kernels as determined by the R^2 , Adjusted R^2 , Reduced χ^2 and RMSE values. The effective moisture diffusivity was determined to be $5.04 \times 10^{-11} \text{ m}^2.\text{s}^{-1}$. The activation energy was determined to be 3.02 kW.kg^{-1} . The energy consumption was determined to be $1.05 \text{ kWh.}[\text{kg-grain}]^{-1}$ with a drying efficiency of 18.89%. The drying cost for a ton of parboiled rough rice was \$88.31 at a commercial energy rate of 8.41 cents per kWh in the state of Arkansas (2020). The models and parameters found in this study can be applied to industrial designs and act as an operational guide for the MW drying of parboiled rice.

ACKNOWLEDGEMENTS

There are several people without whom this dissertation might not have been written, and to whom I am greatly indebted.

To my mother, Dorothy, who continues to learn, grow and develop and who has been a source of encouragement and inspiration to me throughout my life, a very special thank you for providing a 'writing space' and for nurturing my inquisitive nature. Moreover, also for the myriad of ways in which, throughout my life, you have actively supported me in my determination to find and realize my potential, and to contribute to our world.

To my advisor, Dr. Griffiths Atungulu for the deft ways in which you benevolently challenged and supported me throughout the entirety of this work; knowing when to push and when to let up. Thank you to my lab mates, a group of diverse millennials who provided motivation, help and made the lab environment a bit friendlier.

I extend special thanks to my committee members, Dr. Sammy Sadaka, Dr. Terry Siebenmorgen, Dr. Andy Mauromoustakos and Dr. Ruben Morawicki for their useful feedback and insightful comments on my work. Making it through this project without their help would be impossible.

Many thanks are given to the staff and faculty of the University of Arkansas's Rice Processing Program, especially Dr. Ya-Jane Wang, for the guidance and gracious lending of equipment and knowledge.

I must also acknowledge AMTeK Microwaves (Cedar Rapids, Iowa) for research suggestions and provision of the equipment used in this study.

Finally, I would like to thank my cat, Leo, for keeping me sane for the past 5 years.

TABLE OF CONTENTS

CHAPTER 1: INTRODUCTION	1
HYPOTHESIS.....	8
OBJECTIVES.....	9
REFERENCES	11
CHAPTER 2: PROCESSING PARAMETERS FOR ONE-PASS DRYING OF HIGH-MOISTURE PARBOILED ROUGH RICE WITH 915 MHZ MICROWAVES	15
INTRODUCTION	16
METHODS.....	20
Parboiling Procedure.....	21
Microwave Equipment and Treatments.....	22
Rice Milling	24
Crude Protein Determination	25
Surface Lipid Content Determination	25
Determination of Color Values.....	25
Statistical Analysis.....	27
RESULTS AND DISCUSSION.....	28
Implications of Soaking Temperature and Steaming Duration on Moisture Content, Milled Rice Yield and Head Rice Yield.....	28
Implications of Soaking Temperature and Steaming Duration on Protein Content, Surface Lipid Content and Total Color Difference.....	30
Implications of Microwave Specific Energy, Soaking Temperature and Steam Duration on Physicochemical and Milling Characteristics.....	34

CONCLUSION.....	52
ACKNOWLEDGEMENTS.....	53
REFERENCES	54
 CHAPTER 3: IMPACTS OF SPECIFIC POWER OF MICROWAVE AT 915 MHZ	
FREQUENCY ON DRYING AND MILLING CHARACTERISTICS	
OF PARBOILED ROUGH RICE.....	59
INTRODUCTION	60
METHODS.....	63
Parboiling Procedure.....	64
Microwave Equipment and Treatments.....	65
Rice Milling	68
Statistical Analysis.....	69
RESULTS AND DISCUSSION.....	69
Impact of Specific Power on Drying Characteristics.....	69
Impacts of Specific Power on Milled Rice Yield and Head Rice Yield.....	72
CONCLUSION.....	77
ACKNOWLEDGEMENTS.....	79
REFERENCES	80
 CHAPTER 4: HEAT AND MASS TRANSFER CHARACTERISTICS IN PARBOILED	
RICE DURING HEATING WITH 915 MHZ MICROWAVE ENERGY	82
INTRODUCTION	83
METHODS.....	85
Differential Scanning Calorimetry.....	85

Parboiling Procedure.....	86
Control Samples	86
Microwave Equipment and Treatments	87
Drying Characteristics and Modeling	88
Determination of Effective Moisture Diffusivity.....	90
Calculation of Activation Energy in Microwave Drying.....	92
Statistical Analysis.....	93
RESULTS AND DISCUSSION.....	94
Gelatinization Properties	94
Parboiled Rice Moisture Removal Characteristics.....	95
Drying Rate	97
Drying Models.....	100
Effective Moisture Diffusivity.....	102
Activation Energy.....	103
CONCLUSION.....	104
ACKNOWLEDGEMENTS.....	106
REFERENCES	107

CHAPTER 5: ENERGY USE ASSOCIATED WITH ONE-PASS DRYING OF

PARBOILED ROUGH RICE WITH MICROWAVES AT 915 MHZ.....	110
INTRODUCTION	111
METHODS.....	113
Parboiling Procedure.....	114
Microwave Equipment and Treatment	115

Drying Energy and Efficiency Determination.....	117
Rice Milling	118
Statistical Analysis.....	118
RESULTS AND DISCUSSION.....	119
Parboiling Conditions of Soaking Temperature.....	119
Moisture and Temperature Profiles.....	119
Drying Energy Requirement and Efficiency.....	123
Post-Drying Rice Characteristics.....	126
CONCLUSION.....	128
ACKNOWLEDGEMENTS.....	130
REFERENCES	131
CHAPTER 6: PROJECT CONCLUSIONS	134

CHAPTER 1: INTRODUCTION

Rough rice sometimes referred to as paddy rice, is harvested directly from rice fields at high moisture content (MC) (typically around 20% wet basis). The grain is then dried down to safe storage MC of 12.5 to 13.5% wet basis (henceforth MC is in % wet basis) to avoid quality deterioration. Rough rice is made up of an outer hull, germ and bran layers with an inner starchy endosperm. Unlike some of the protective hulls found in many natural foods, the hull on rice is not edible, and thus is usually removed during processing, yielding brown rice kernels. Further processing is often done to remove the bran and germ layers to yield milled white rice kernels. Globally, approximately 480 million metric tons of milled rice is produced annually. Rice milling, however, results in the loss of a significant amount of B vitamins and minerals that are found in the outer germ and bran layers. Consequently, populations that subsist on white rice are at high risk of vitamin and mineral deficiency (Muthayya et al. 2014). In addition to nutrient losses, the harsh conditions during the milling process can also encourage the development of fissures that can then lead to head rice yield reductions.

The head rice yield (HRY) comprises milled rice kernels that are at least three-fourths of the original milled rice kernel length. HRY represents the mass percentage of a rough rice lot that remains as head rice after milling. Preventing HRY reduction during drying is very critical and bears significant economic importance to the rice industry (Cnossen and Siebenmorgen, 2000). The HRY is often the most critical quality parameter to rice millers since the HRY is linked to payment received for rice delivered at milling facilities. Under ideal conditions, a perfect HRY recovery would be about 70% of the total rough rice produced after the rice hulls and bran are removed. However, with current conventional rice drying methods, HRY recovery averages only about 58%, and can be even lower depending on other pre-harvest and post-harvest factors (USDA,

2014; Atungulu et al. 2016). Parboiling, however, presents an opportunity to reduce nutrient and HRY losses during milling.

Parboiling is an energy and labor-intensive hydrothermal treatment that involves soaking the rice in water and steaming it under intense pressure. Parboiling makes rough rice less likely to break during milling and pushes nutrients from the bran layer into the endosperm, making parboiled white rice 80% nutritionally like brown rice kernels. Parboiled rice typically sells at a premium to regular milled rice (Chukwu, 1999). Parboiled rice is a favorable candidate for many convenience rice dishes produced by the food industry because the cooked rice kernel has reduced stickiness, and can sustain the industrial processes of cooking, freezing and canning without significant reduction in kernel integrity (FAO, 1998, Strandt, et al. 1995, Ong and Blanshard, 1995). In addition to improving rice's resistance to spoilage by insects and mold, parboiling also inactivates the lipase in the bran layer of brown rice, thusly reducing oxidative rancidification. As a result, parboiling improves the shelf life of parboiled brown rice products (Bhattacharya, 1985); Elbert et al., 2001).

The first step in the parboiling process is the soaking step. The main objective of this step is to allow the rice kernels to absorb water and to initiate the starch's gelatinization. Gelatinization is the process of breaking down the intermolecular bonds of starch molecules in the presence of water and heat, subsequently softening the starch granules. When the starch granules begin to swell, they begin to fill voids in the starchy endosperm, cementing fissures and effectively increasing the HRY. During soaking, the grain quickly absorbs moisture and can reach high MCs of 30-35% in 2 to 4 hours, depending on the cultivar.

After soaking, the wet rough rice is heat-treated to complete the physicochemical changes of starch gelatinization. The use of steam is most preferred to other methods of heating, as it does

not remove moisture from the rough rice. The condensation from the steaming process adds water and increases the rough rice MC to about 38%.

The commercial rice milling industry uses cross-flow dryers and rotary dryers in combination and at different temperatures to dry high MC parboiled rough rice. Rotary dryers are used to partially dry parboiled rough rice before loading it into the cross-flow dryer.

Rotary dryers consist of a metal cylinder with internal flights or louvers. The cylinder is slightly inclined, and the parboiled rice is fed at the high end and discharged at the low end while hot air is being blown co-current or countercurrent to the direction of grain flow. Rotary dryers require drying air temperatures of up to 100°C. During drying, moisture removal takes place rapidly in the first stage of drying when the rice is at MC range of 36 to 18% w.b.; this is when a lot of the water is at the surface of the rice kernel. After the parboiled rough rice is dried to about 18% M.C. it is then transported to a cross-flow dryer to complete the drying process (Wimberly, 1983). A schematic of a rotary dryer with co-current airflow is seen in figure 1.1.

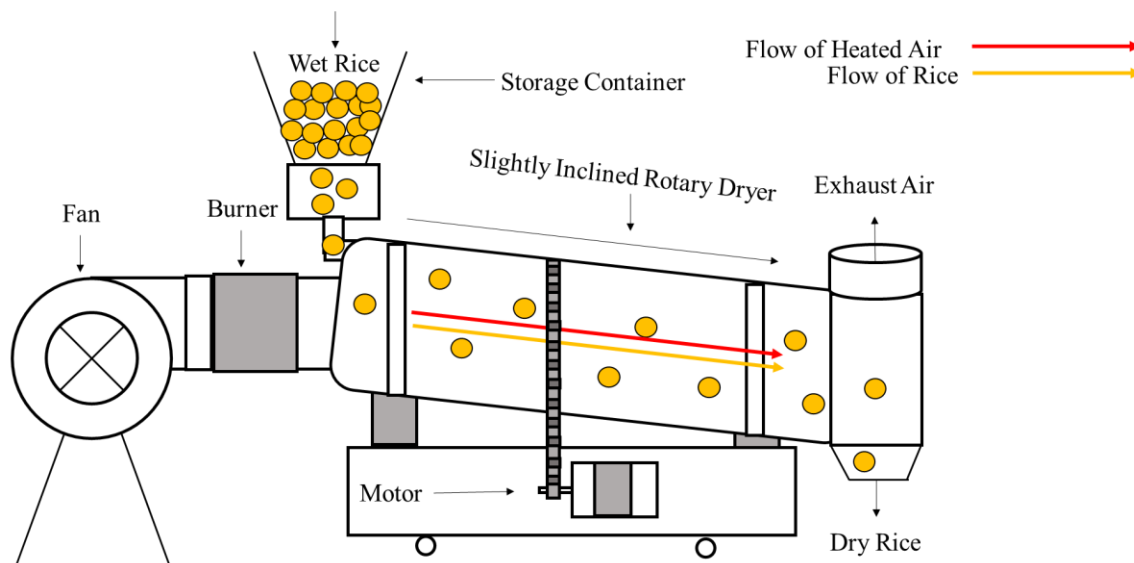

Figure 1.1: Schematic of a rotary dryer with co-current airflow

Cross-flow dryers consist of a metal column by which grain flows down due to gravity as the heated air blows across the grain column perpendicular to the grain flow (Rumsey and Rovedo, 2001; Schluterman and Siebenmorgen, 2004). Drying air temperatures of up to 75°C are used in cross-flow dryers (Wimberly, 1983). A schematic of a cross-flow dryer with perpendicular airflow is seen in figure 1.2.

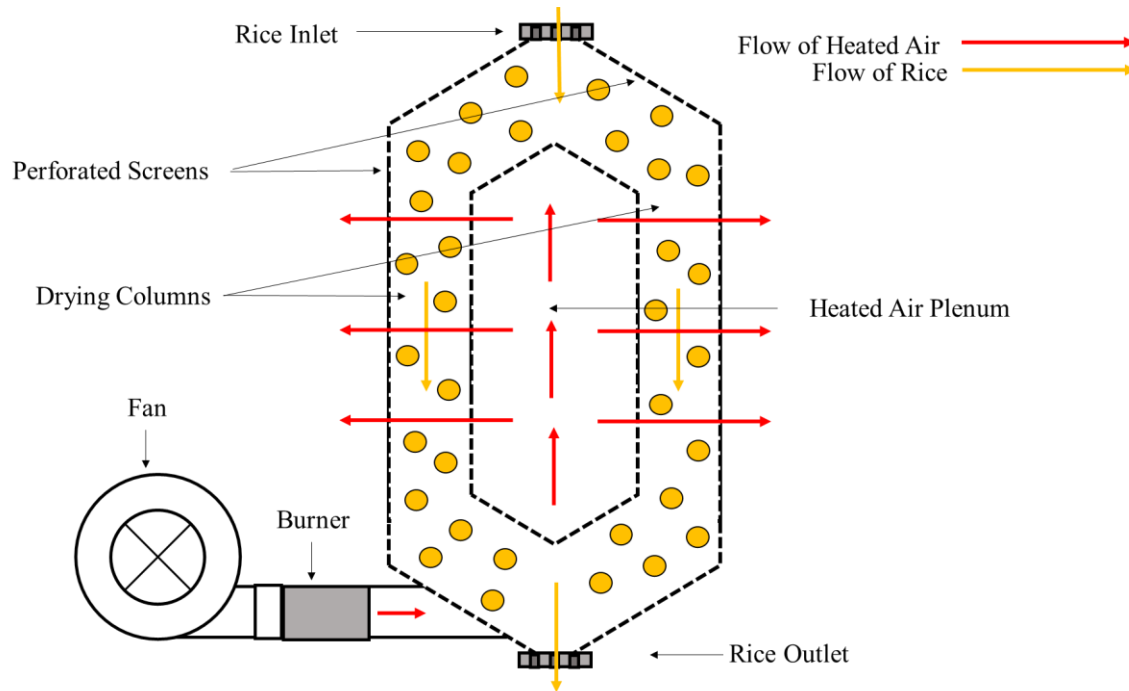

Figure 1.2: Schematic of a cross-flow dryer with perpendicular airflow

Between drying periods, rice millers employ a tempering step by stopping the drying process at about 18% MC to allow the rough rice MC to equilibrate for several hours before continuing the drying to 14%. Tempering ensures that moisture gradients that develops during drying in the grain bulk are minimized. Moisture gradients often lead to fissuring. By minimizing moisture gradients grain quality and thus HRY is maintained.

Parboiling and drying operations consume more than 90% of the total energy needed in a rice milling system (Islam et al. 2004). Kasmaprapuet et al. (2009) reported that the drying step

alone was the most energy-intensive unit operation in a rice milling system, accounting for approximately 55% of the total energy consumed. Kalchik et al. (1981) reported on a parboiled rough rice drying operation that used a high temperature column dryer to dry a ton of high MC parboiled rough rice. The energy requirement was calculated to be in the range of 489 kWh to 632 kWh to dry a ton of parboiled rough rice from an initial MC of 35% to 15.5%. However, it should be noted that the energy used to dry parboiled rough rice can vary considerably depending on many factors including the type and variety of grain, drying air temperature, relative humidity, airflow rate (and thus drying rate), and the initial and final MC of the parboiled rough rice (Simmonds et al., 1953; Henderson & Pabis, 1961; Otten et al., 1980; Cenkowski et al., 1992; Mulet et al., 1999; Cnossen et al., 2002; Iguaz et al., 2003; Aviara et al., 2004; Toğrul & Arslan, 2006). Additionally, although the equipment in most rice parboiling plants is very similar, the energy management and, consequently, the energy requirements of each parboiling plant may differ (Sehgal et al. 1982).

This dissertation investigated a novel microwave (MW) method for drying parboiled rough rice. MWs are electromagnetic radiations with wavelengths approximately in the range of 30 cm (frequency = 1 GHz) to 1 mm (300 GHz). The frequencies reserved by the Federal Communications Commission (FCC) for industrial, scientific, and medical (ISM) purposes used for MW heating applications are 2450 MHz (2.45 GHz) and 915 MHz (0.915 GHz). The frequency choice is dictated by application-specific characteristics such as the permittivity of a material (Stuerga, 2006).

MW drying of agricultural materials occurs because of exposure to electromagnetic radiation in the MW frequency range. This electromagnetic radiation induces polar molecules in the product to rotate and produce thermal energy in a process known as dielectric heating. Dielectric heating is a form of heating in which an electrically insulating material is heated by

being subjected to an alternating electric field. When MW radiation is incident on a dielectric material, the molecules of the material try to align themselves with the rapidly alternating electric field component of the MWs. At high frequencies, the inertia of the molecules retards this alignment, and the dipole motion lags behind the electric field. At MW frequencies, the phase lag absorbs power from the applied field, an effect known as dielectric loss. This power loss manifests as dielectric heating (Schiffmann, 1995).

MW heating is fundamentally different from conventional heating. During MW heating, heat is evenly distributed throughout the entire volume of a flowing liquid, suspension, or semi-solid. This contrasts with traditional thermal processing, which relies on conduction and convection from hot surfaces to deliver energy into the product. MW heating is very rapid as the material is heated by energy conversion rather than by energy transfer as with conventional techniques. MW heating is a function of the material being processed, and there is almost 100% conversion of electromagnetic energy into heat, mainly within the sample itself, unlike with convective heating where there are significant thermal energy losses.

In convective drying systems, a bed or layer is sufficiently deep to extract a reasonable portion of the energy from the drying air. The layer nearest the incoming air begins to dry immediately, at its highest rate, acting as a thin layer. Successive layers start losing moisture only after the preceding ones no longer absorb all the drying potential from the air (Bern et al., 2019). In the case of MW heating, the drying is not controlled by the drying air (e.g., velocity, temperature, and relative humidity) but by the MW penetration depth and energy intensity. MW penetration depth is a measure of how deep the MW radiation can penetrate a given material. Penetration depth is defined as the depth at which the intensity of the radiation inside the material falls to $1/e$ (about 37%) of its original value at the surface. The parameters affecting the depth of

the MW field into a material are the wavelength, the dielectric constant, and the loss factor. Industrial MWs with a frequency of 915-MHz penetrate to a greater depth than does the 2450-MHz frequency making the use of industrial MWs with 915 MHz frequencies suitable for large-scale drying of agricultural products.

Many recent studies focus on the MW processing of agricultural products as well as by-products. To investigate the drying efficiency and energy costs of a MW employed for the dehydration of apple fruit, Hazervazifeh, et al. (2017) revealed that MW dehydration is highly time-efficient with an 80% reduction in processing durations compared to convectively heated air-drying methods. They went further to state that this high drying efficiency was reduced by 99% in the convectively heated air-drying scenario. MW dehydration also decreased energy costs in the drying of apple fruit by 60 %. Soysal (2004) found that when compared to hot air drying, MW drying technology can significantly reduce the drying duration and successfully produce good quality dried parsley flakes in terms of color. Sharma (2006) found that the quality of garlic cloves, dehydrated by a hybrid MW-convective drying process, was superior to the commercial sample dried using convective only methods. Alibas (2007) sought to determine the energy consumption and color characteristics of nettle leaves during MW, vacuum, and convective drying. The author found that the optimum method was the MW drying at 850 W for durations of 4 to 6 minutes as it provided the lowest drying period and energy consumption and best color characteristics. Wang et al. (2007) also researched the aspects of thin layer MW drying of apple pomace in a laboratory-scale MW dryer. They determined that the drying duration of apple pomace decreased compared to convective drying methods. The effective diffusivity also increased as the MW output power increased. Therdthai and Zhou (2009), in their research, were able to determine the characteristics of MW vacuum drying and hot air drying of mint leaves. Their study found that the effective

moisture diffusivity was significantly increased when MW drying was applied under vacuum condition, compared with hot air drying and that the color of the MW vacuum dried mint leaves was light green/yellow. In contrast, the hot air-dried mint leaves were dark brown. Additionally, many studies on the applications of MW for heating of beef, pork, and milk showed equal or better retention of some vitamins (B1, B2, B6, C, and folic acid) after MW heating compared with conventional heating (Cross and Fung 1982; Hoffman and Zabik 1985).

MW heating at the 915 MHz frequency exemplifies a technology with great application possibilities in parboiling. In addition to the benefits of improved physical and chemical characteristics, MW parboiling may offer significant energy savings, shorter processing durations, and increased penetration depth (Bhattacharya and Ali, 1985; Marshall and Wadsworth, 1994; Wang et al., 2003; Smith et al., 2018). The optimization of MW drying of parboiled rough rice to attain high HRY requires vital information on the moisture diffusion behavior in parboiled rough rice kernels exposed to MW energy at the 915 MHz frequency. Simulation models are handy for analysis of drying processes. Several successful drying models have been developed to explain the convective drying kinetics of various agricultural products (Ertekin, and Firat, 2017). However, less effort has been made to model MW drying of parboiled rough rice.

HYPOTHESIS

Based on the literature review, the central hypotheses for this study are that:

1. To have better results with MW drying of parboiled rough rice, there exists an optimum pre-drying steaming and soaking condition that provides desirable parboiled rough rice final moisture content, milled rice yield, head rice yield, and physicochemical properties, including the total color difference, surface lipid content, and protein content.

2. One-pass drying of parboiled rough rice to safe storage MC is attainable; however, increased MW specific energy and energy fluxes will negatively correlate with the rice milling and quality attributes.
3. Moisture removal related characteristics such as drying rate, effective moisture diffusivity and activation energy associated with MW drying of parboiled rough rice will demonstrate the superiority of the new process over the conventional convective heated air drying.
4. The calculated energy requirements and costs associated with the MW drying of parboiled rough rice will be similar to or less than that of conventional drying methods.

OBJECTIVES

At present, there is no commercial use of microwave technology for parboiled rough rice drying. Therefore, the overall purpose of this study was to develop a microwave heating technology that can sufficiently dry high MC parboiled rough rice kernels in one pass using a 915-MHz industrial microwave system. As a result, the objectives of this study were four-fold:

1. Determine the implications of pre-drying steaming and soaking conditions on parboiled rough rice final moisture content, milled rice yield, head rice yield, and physicochemical properties, including the total color difference, surface lipid content, and protein content.
2. Determine the implications of increased MW energy fluxes on parboiled rough rice final moisture content, milled rice yield, and head rice yield.
3. Investigate the heat and moisture transport phenomena in high moisture long grain parboiled rough rice kernels, including the moisture removal rate, the effective moisture diffusivity characteristics, and the activation energy of the process.

4. Determine the energy requirements, efficiency, and costs associated with single-pass MW drying of parboiled rough rice and the associated milled rice quality characteristics.

REFERENCES

- Alibas, I. (2007). Energy consumption and colour characteristics of nettle leaves during microwave, vacuum and convective drying. *Biosystems Engineering*, 96 (4), 495-502.
- Arora, B. K. (1982). Engineering management for a rice-mill. Proceeding of National Workshop on Rice Husk for Energy. Aug 25–27. New Delhi, National Productivity Council
- Atungulu, G. G., Smith, D. L., Wilson, S. A., Zhong, H., Sadaka, S., & Rogers, S. (2016). Assessment of one-pass drying of rough rice with an industrial microwave system on milling quality. *Applied Engineering in Agriculture*, 32(3), 417-429.
- Aviara, N.A., Ajibola, O.O., Oni, S.A., 2004. Sorption equilibrium and thermodynamic characteristics of soya bean. *Biosystems Engineering* 87 (2), 179–190.
- Bern, C. J., Quick, G., & Herum, F. L. (2019). Harvesting and post-harvest management. In *Corn* (pp. 109-145). AACC International Press.
- Bhattacharya, K. R. (1985). Parboiling of rice. *Rice chemistry and technology*. American Association of Cereal Chemists Inc, St. Paul, MN. 289–348.
- Bhattacharya, K. R., & Ali, S. Z. (1985). Changes in rice during parboiling, and properties of parboiled rice. *Advances in cereal science and technology (USA)*.
- Cenkowski, S., Jayas, D. S., & Hao, D. (1992). Latent heat of vaporization for selected foods and crops. *Canadian Agricultural Engineering*, 34(3), 281-286.
- Chukwu, O. (1999). Parboiling of rice paddy with heated pebbles. *Journal of Science, Technology and Mathematics Education*. 70-76.
- Cnossen, A. G., Jimenez, M. J., & Siebenmorgen, T. J. (2003). Rice fissuring response to high drying and tempering temperatures. *Journal of food engineering*, 59(1), 61-69.
- Cnossen, A. G., Siebenmorgen, T. J., & Yang, W. (2002). The glass transition temperature concept in rice drying and tempering: effect on drying rate. *Transactions of the ASAE*, 45(3), 759.
- Cross, G. A., Fung, D. Y., and Decareau, R. V. (1982). The effect of microwaves on nutrient value of foods. *Critical Reviews in Food Science and Nutrition*, 16(4), 355-381.
- Elbert, G., Tolaba, M. P., & Suárez, C. (2001). Effects of drying conditions on head rice yield and browning index of parboiled rice. *Journal of food engineering*, 47(1), 37-41.
- Ertekin, C., and Firat, M. Z. (2017). A comprehensive review of thin-layer drying models used in agricultural products. *Critical reviews in food science and nutrition*, 57(4), 701-717.

- FAO, (1998). Physical activity: impact of protein and amino metabolism and implication for nutritional requirements. World Health Organization (WHO) Technical Report, Geneva, Ser. No 522.
- Hazervazifeh, A., Moghaddam, P. A., and Nikbakht, A. M. (2017). Microwave dehydration of apple fruit: Investigation of drying efficiency and energy costs. *Journal of Food Process Engineering*, 40(3).
- Henderson, S. M., & Pabis, S. (1961). Grain drying theory I: Temperature effect on drying coefficient. *Journal of Agricultural Engineering Research*, 7, 85–89.
- Hoffman, C. J., Zabik, M. E., (1985). Effects of microwave cooking/reheating on nutrients and food systems: A review of recent studies. *J. Am. Diet Assoc.* 1985, 85, 929–933.
- Iguaz, A., Vírveda, P., 2007. Moisture desorption isotherms of rough rice at high temperatures. *Journal of Food Engineering* 79 (3), 794–802
- Islam, M. R., Shimizu, N., and Kimura, T. (2004). Energy requirement in parboiling and its relationship to some important quality indicators. *Journal of Food Engineering*, 63(4), 433-439.
- Kalchik, S. J., Silva, J., Mwaura, E. N., Rodriguez, J. C., & Bakker-Arkema, F. W. (1981). On-farm corn drying comparison. Paper-American Society of Agricultural Engineers (Microfiche collection)(USA).
- Kasmaprapruet, S., Paengjuntuek, W., Saikhwon, P., & Phungrassami, H. (2009). Life Cycle Assessment of Milled Rice Production: Case Study in Thailand. *European Journal of Scientific Research*, 30(2), 195-203.
- Marshall, W. E., and Wadsworth, J. I. (1994). Chapter 1: introduction. *Rice Science and Technology*, 1-15.
- Mulet, A., García-Reverter, J., Sanjuán, R., & Bon, J. (1999). Sorption isosteric heat determination by thermal analysis and sorption isotherms. *Journal of Food Science*, 64(1), 64-68.
- Muthayya, S., Sugimoto, J. D., Montgomery, S., and Maberly, G. F. (2014). An overview of global rice production, supply, trade, and consumption. *Annals of the New York Academy of Sciences*, 1324(1), 7-14.
- Ong, M.H. and Blanshard, J.M.V. (1995). Texture determinants of cooked, parboiled rice. II: Physicochemical properties and leaching behaviour of rice. *Journal of Cereal Science*, 21(3), 261-269.
- Otten, L. R. (1980). A study of a commercial cross-flow dryer. *Canadian Agric. Eng.*, 22(2), 163-170.

- Rumsey, T. R., & Rovedo, C. O. (2001). Two-dimensional simulation model for dynamic cross-flow rice drying. *Chemical Engineering and Processing: Process Intensification*, 40(4), 355-362.
- Schiffmann, R. F. (1995). *Microwave and Dielectric. Handbook of Industrial Drying, Revised and Expanded*, 1, 345.
- Schluterman, G. J., & Siebenmorgen, T. J. (2004). Air and rice property profiles within a commercial cross-flow rice dryer. *Applied engineering in agriculture*, 20(4), 487.
- Sehgal, V. K., Grover, P. C., and Bhatnagar, A. P. (1982). Energy assesment for parboiling and drying operations in Punjab rice mills. *Agril Engg Today*, 6(2), 24-27.
- Sharma, G. P., and Prasad, S. (2006). Optimization of process parameters for microwave drying of garlic cloves. *Journal of Food Engineering*, 75(4), 441-446.
- Simmonds, W. H. C., Ward, G. T., & McEwen, E. (1953). The drying of wheat grain. Part I: The mechanism of drying. *Trans. Inst. Chem. Eng*, 31(3), 265-278.
- Smith, D. L., Atungulu, G. G., Sadaka, S., & Rogers, S. (2018). Implications of microwave drying using 915 MH z frequency on rice physicochemical properties. *Cereal Chemistry*, 95(2), 211-225.
- Soysal, Y. (2004). Microwave drying characteristics of parsley. *Biosystems engineering*, 89(2), 167-173.
- Strandt, T.; Vorwerck, K.; Muenzing, K. (1995). Contributions to evaluation of quality of parboiled rice and on parboiling effects. *Getreide Mehl und Brot (Germany)*, 49(4), 237-242.
- Stuerga, D. (2006). Microwave-material interactions and dielectric properties, key ingredients for mastery of chemical microwave processes. *Microwaves in organic synthesis*, 2, 1-59.
- Therdthai, N., and Zhou, W. (2009). Characterization of microwave vacuum drying and hot air drying of mint leaves (*Mentha cordifolia* Opiz ex Fresen). *Journal of Food*
- Toğrul, H., & Arslan, N. (2006). Moisture sorption behaviour and thermodynamic characteristics of rice stored in a chamber under controlled humidity. *Biosystems Engineering*, 95(2), 181-195.
- USDA. (2014). *Crop and stocks report*. USDA-National Agricultural Statistics Service Arkansas. Retrieved from <http://www.nass.usda.gov/>
- Wang, S., Tang, J., Johnson, J. A., Mitcham, E., Hansen, J. D., Hallman, G., and Wang, Y. (2003). Dielectric properties of fruits and insect pests as related to radio frequency and microwave treatments. *Biosystems Engineering*, 85(2), 201-212.

Wang, Z., Sun, J., Chen, F., Liao, X., and Hu, X. (2007). Mathematical modelling on thin layer microwave drying of apple pomace with and without hot air pre-drying. *Journal of Food Engineering*, 80(2), 536-544.

Wimberly, J. E. (1983). *Technical handbook for the paddy rice post-harvest industry in developing countries*. International Rice Research Institute.

CHAPTER 2: PROCESSING PARAMETERS FOR ONE-PASS DRYING OF HIGH-MOISTURE PARBOILED ROUGH RICE WITH 915 MHZ MICROWAVES

ABSTRACT

The volumetric heating phenomenon of microwave (MW) offers a means to quickly dry high moisture content (MC) parboiled rough rice in one-pass. However, to successfully dry the parboiled rough rice in one pass using MW while also preserving the milled rice yields and quality characteristics, it is vital to investigate the impacts of the pre-drying parboiling conditions on the drying process and resulting product characteristics. The objectives of this research were to explore the feasibility of using a MW set at 915 MHz frequency to dry high MC parboiled rough rice and to determine the implications of pre-drying soaking and steaming conditions on the parboiled rough rice final moisture content (FMC), milled rice yield (MRY), head rice yield (HRY) and the milled rice physiochemical properties. Freshly-harvested, long-grain rough rice of the cultivar Mermentau at MC of 31.58% dry basis (d.b.) was used in the study. The parboiling process involved soaking the rough rice in water at temperatures of 71, 73, and 76 °C, and steaming for 5, 10, and 15 mins. After parboiling, samples of rough rice for the controlled experiment were gently dried with natural air at 25 °C and 65% relative humidity whereas those for treatments were dried using the 915 MHz MW dryer which was set to deliver energy ranging from 0.04 to 0.29 kWh per kg of the rough rice dry matter content ($\text{kWh} \cdot [\text{kg-DM}]^{-1}$). The MW powers applied during the treatment ranged from 1 to 8 kW with heating durations of up to 6 mins. The rough rice MC immediately after the soaking and steaming processes increased; ranged from 42.59 to 48.21% d.b. Increasing soaking temperature led to increased uptake of water after parboiling, decreases in MRV, HRY, protein content, and milled rice surface lipid content (SLC) and increased total color

difference (TCD). Increasing steaming duration led to decreased moisture uptake during steaming, decreased MRY, protein content, SLC and TCD and increased HRY. Increasing MW specific energy led to decreases in rice FMC, HRY, protein content, and SLC and increased TCD. It is recommended that the long-grain rough rice should be soaked at 73 °C, steamed for 10 min, then treated at MW specific energy of 0.29 kWh.[kg-DM]⁻¹ in one pass to achieve parboiled rough rice FMC of 18.79% d.b., and HRY of 69.33%, and desirable parboiled milled rice physicochemical and sensory properties. At the same parboiling conditions, the control samples had MRY of 74.98%, and HRY of 74.07%. MW specific energy greater than 0.29 kWh.[kg-DM]⁻¹ was necessary to dry the parboiled rough rice to MC safe for long-term storage (14.29% to 15.61% d.b). However, application of specific energy beyond the 0.29 kWh.[kg-DM]⁻¹ caused reduction of the HRY below that of control samples. Therefore, to preserve HRY, rice processors should use MW specific energy of 0.29 kWh.[kg-DM]⁻¹ to partially dry the parboiled rice and then complete the drying to the safe storage MC by using natural or slightly-heated. This study demonstrated the feasibility of using 915 MHz MW heating of high-MC parboiled rough rice to achieve one-pass drying.

Keywords: One-Pass Drying; 915 MHz Microwave; Milling Yields; Parboiled rough rice; Physicochemical Properties; Quality.

INTRODUCTION

World rice production is approximately 618 million tons per year, and about 50% of the world rice production is parboiled (Rahimi-Ajdadi et al., 2018). Parboiling is an energy and labor-intensive hydrothermal treatment aimed at improving the nutritional and milling qualities of white

rice. The parboiling process involves the three necessary steps of soaking, steaming, and then drying (Chukwu, 1999). Parboiled rice is a favorable candidate for many convenience rice dishes produced by the food industry because the cooked rice kernel has reduced stickiness, increased head rice yield (HRY). Parboiled rice can also sustain the industrial processes of cooking, freezing and canning without significant reduction in kernel integrity (Bauer and Knorr, 2004; Ituen and Ukpakha, 2011; Taghinezhad et al., 2016). Additionally, parboiling drives nutrients from the bran to the endosperm, making parboiled white rice 80% nutritionally similar to brown rice (Akhter et al., 2014). Furthermore, parboiling inactivates the lipase in the bran layer of brown rice; this reduces oxidative rancidification and improves the shelf life of parboiled brown rice products (Koh and Surh, 2016).

The first step in the parboiling process is the soaking step. During soaking, the grain quickly absorbs moisture and can reach high moisture contents (MC) of 43-54% dry basis (d.b) in 2 to 4 hours depending on the cultivar. After soaking, the wet rough rice is steamed to complete the physicochemical changes of starch gelatinization. The condensation from the steaming process adds water and increases the rough rice MC to about 61% d.b. (henceforth MC is in dry basis unless stated otherwise) (Wimberly, 1983). Drying the parboiled rough rice to MCs necessary for safe storage conditions (14.29% to 15.61%) is necessary to preserve the quality of rice.

Over 85% of industrial dryers are of the convective type using hot air (Mujumdar & Devahastin, 2008). With current conventional convective air-drying processes, not only is the drying of high MC parboiled rough rice energy-intensive, but the drying rate is low, thereby creating drying capacity bottlenecks at parboiling facilities especially at peak harvest times. As demand for parboiled rough rice continues to increase, with subsequent expansion of parboiled rough rice production in the United States to meet this demand, there is a critical need to improve

the current parboiled rough rice drying process. Improvements can be made to minimize energy use and costs, to increase throughput by reducing processing times, and to ensure food quality (FAOSTAT, 2007; Ricestat, 2007).

Microwave (MW) drying has gained a renewed interest in both academia and industry as an alternative to conventional hot air drying. MW heating is fundamentally different from conventional heating. MW heating is very rapid as the material is heated by energy conversion rather than by energy transfer as with conventional drying techniques. MW heating is a function of the material being processed, and there is almost 100% conversion of electromagnetic energy into heat, mainly within the sample itself, unlike with convective heating where there are significant thermal energy losses. During MW heating, electromagnetic energy is absorbed and is converted directly into heat, which is evenly distributed throughout the entire volume of a flowing liquid, suspension, or semi-solid.

Many recent studies focus on the MW processing of agricultural products as well as by-products. To investigate the drying efficiency and energy costs of a MW employed for the dehydration of apple fruit, Hazervazifeh, et al. (2017) revealed that MW dehydration is highly time-efficient with an 80% reduction in processing durations compared to convectively heated air-drying methods. They went further to state that this high drying efficiency was reduced by 99% in the convectively heated air-drying scenario. MW dehydration also decreased energy costs in the drying of apple fruit by 60%. Soysal (2004) found that when compared to hot air drying, MW drying technology can significantly reduce the drying duration and successfully produce good quality dried parsley flakes in terms of color. Alibas (2007) sought to determine the energy consumption and color characteristics of nettle leaves during MW, vacuum, and convective drying. The author found that the optimum method was the MW drying at a power level of 850 W for

durations of 4 to 6 minutes as it provided the lowest drying period and energy consumption and best color characteristics. Wang et al. (2007) also researched the aspects of thin layer MW drying of apple pomace in a laboratory-scale MW dryer. They determined that the drying duration of apple pomace decreased compared to convective drying methods. Additionally, many studies on the applications of MW for heating of beef, pork, and milk showed equal or better retention of some vitamins (B1, B2, B6, C, and folic acid) after MW heating compared with conventional heating (Cross and Fung, 1982; Hoffman and Zabik, 1985).

Two MW frequencies are authorized for use in MW ovens: 915 and 2450 MHz. Both are useful for food processing; however, they are markedly different, and these differences make them useful for different scenarios. The major differences between MWs at 915 and 2450 MHz include the amount of power they provide. The magnetron of a 915 MHz MW can provide up to 100 kW. Whereas the magnetron of a 2450 MHz, although similar in cost, can provide powers up to 30 kW. It is also purported that one 100 kW generator for a 915 MHz MW can be approximately 50% cheaper than seven 15 kW generators for a 2450 MHz MW. The penetration depth of electromagnetic energy provided by a MW at 915 MHz frequency is about three times greater than that provided by a MW at 2450 MHz. This is due to the wavelengths in free space at the 915 and 2450 MHz frequency being 32.78 and 12.24 cm, respectively (Hui & Evranuz, 2015). Additionally, the energy attenuation of a 915 MHz MW is less than that of a 2450 MHz MW as a result in the case for a 915 MHz MW more electromagnetic energy is converted to heat energy (Sun et al., 2009).

Atungulu et al. (2016) demonstrated the feasibility of using an industrial-type MW heating system at the 915 MHz frequency to achieve one-pass drying of freshly-harvested medium-grain rough rice. The authors found that the volumetric heating and the high heat flux accorded by the

MWs were able to achieve single-pass rice drying of freshly harvested, high MC rice at an initial MC of 31.58% to safe storage MC (14.29% to 15.61%) with improved HRYs. In addition to the benefits of improved physical and chemical characteristics, MW parboiling may offer significant energy savings, shorter processing durations, and increased penetration depth (Bhattacharya and Ali, 1985; Marshall and Wadsworth, 1994; Wang et al., 2003; Smith et al., 2018). However, at present, there is no research on the commercial use of MW technology for parboiled rough rice drying.

The introduction of a drying system that can dry high-MC parboiled rough rice lots to safe storage MC of 14.29% to 15.61%, in one pass, with rice milling and physicochemical properties comparable to or better than conventional drying methods could translate into considerable cost savings for the rice milling industry. However, to successfully dry high-MC parboiled rough rice in one pass using MW while also preserving the milled rice yields and quality characteristics, it is vital to investigate the impacts of the pre-drying parboiling conditions on the MW drying process and product characteristics. Therefore, the objectives of this research were to explore the feasibility of using a MW set at 915 MHz frequency to dry high-MC parboiled rough rice and to determine the implications of pre-drying conditions of soaking and steaming on rough rice final moisture content (FMC), milled rice yield (MRY), head rice yield (HRY) and the parboiled milled rice physiochemical properties such as protein content, surface lipid content (SLC) and total color difference (TCD).

METHODS

Freshly-harvested, long-grain rough rice samples of cultivar Mermentau at MC of 31.58% were used in this study. The cultivar Mermentau is a semi-dwarf, early-maturing long-grain rice

with good grain and milling yields and excellent grain quality. It was chosen for this study as a representative, popular pureline (conventional) rice variety. The rice samples were cleaned using dockage equipment (MCI Kicker Dockage Tester, Mid-Continent Industries Inc., Newton, KS). The equipment uses a series of small-sized sieves to provide a fast, accurate, and consistent way of separating shrunken, broken, scalped material, broken kernels, splits, and dust from rice. The cleaned rough rice samples were stored in a laboratory cold room set at 4°C. At the beginning of the experiments, the samples were retrieved from the cold room and allowed to equilibrate with room temperature (25 °C) overnight before conducting any experiments. The MCs of the samples that were reported in this study were determined using an AM 5200 Grain Moisture Tester (PERTEN Instruments, Hägersten, Sweden), which is calibrated according to Jindal and Siebenmorgen (1987). The FMC of each sample was validated using the oven method by placing 15 g of samples into a conduction oven (Shellblue, Sheldon Mfg., Inc., Cornelius, OR) set at 130°C for 24 h, followed by cooling in a desiccator for at least half an hour (Jindal and Siebenmorgen, 1987).

Parboiling Procedure

A sample of 3600 g of rice was placed into a 45 cm by 45 cm piece of cheesecloth then allowed to soak in a lab-scale hot water bath set to soaking temperatures of 71, 73, and 76 °C for 3 hours. After soaking, the wet rough rice was steamed to complete the physicochemical changes of starch gelatinization. Rice in cheesecloth was steamed in a lab-scale autoclave set to a temperature of 113 °C and pressure of 67 kPa for 5, 10, and 15 mins.

Microwave Equipment and Treatments

The MW (AMTek, Applied Microwaves Technology Inc., Cedar Rapids, IW) used in this research was designed for high power operations (up to 75 kW) and had a frequency of 915 MHz, which may allow heating of a deep rice bed. The system (Fig. 2.1) consists of a transmitter, a wave-guide, and the MW heating zone (oven). The transmitter is a high-powered vacuum tube that works as a self-excited MW oscillator. It is used to convert high-voltage electric energy to MW radiation. The wave-guide consists of a rectangular pipe through which the electromagnetic field propagates lengthwise. It is used to couple MW power from the magnetron into the lab oven. The lab oven is the internal cavity of the MW that provides uniform temperatures throughout while in use.

For each MW treatment, freshly parboiled rough rice samples were placed into MW safe trays for treatments. The outsides of the trays are made of polypropylene with a Teflon coated fiberglass mesh at the bottom to hold the samples. The trays' length, width and height were 40 cm, 30 cm and 5 cm, respectively. The bed thickness of the parboiled rough rice samples was 3.5 cm. The trays with parboiled rough rice samples were set in the oven on the belt and treated for 6 mins in batches with power levels ranging from 1 to 8 kW (Figure 2.2).

MW specific energy was defined as the energy applied per unit mass of the treated product's dry matter (kg-DM). For this research, the reference mass (m) was set as the initial mass of the grain dry matter. The MW specific energy was calculated as follows:

$$Q_s = \frac{p \times t_d}{m \times 3600} \quad (1)$$

Where:

Q_s is the MW energy per unit dry matter mass of treated product (kWh.[kg-DM]⁻¹)

p is the electrical power supplied to the MW (kW)

t_d is the drying duration (s)

m is dry matter mass of the treated product (kg or [kg-DM]⁻¹)

After MW treatments, the samples were transferred immediately to glass jars and sealed airtight. The jars were placed in an environmental chamber (Platinous chamber, ESPEC North America, Inc. Hudsonville, MI) set at a temperature of 60°C. The rice was tempered for 4 h. After the tempering, the rice was spread uniformly on individual trays, transferred to an equilibrium moisture content (EMC) chamber (Platinous chamber, ESPEC North America, Inc. Hudsonville, MI) set at a temperature of 25°C and relative humidity (RH) of 65%. The MW dried parboiled rough rice samples were allowed to cool naturally to 25°C then MC measurements taken.

For control experiments, rough rice samples (3 reps, 3600 g each) were soaked at 71 °C, 73 °C, and 76 °C for 3 hours, then steamed at 67 kPa for 5, 10, and 15 mins. After that, the parboiled rough rice samples were tempered for 4 hours at a temperature of 60 °C. After tempering, the parboiled rough rice was placed in an EMC chamber (Platinous Chamber, ESPEC North America, Inc. Hudsonville, MI) set at 25°C, 65% RH, to allow for gentle drying to MC of 14.29%; the drying lasted 48 hours.

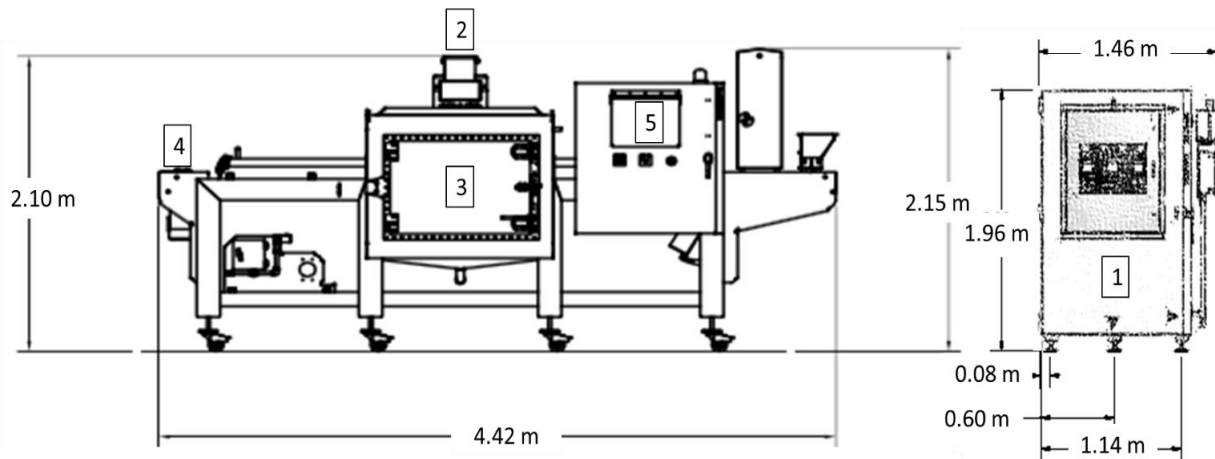

Figure 2.1: Schematic of the microwave system used in the study showing the transmitter (1), wave-guide (2), heating zone (3), conveyor belt (4), and control panel (5).

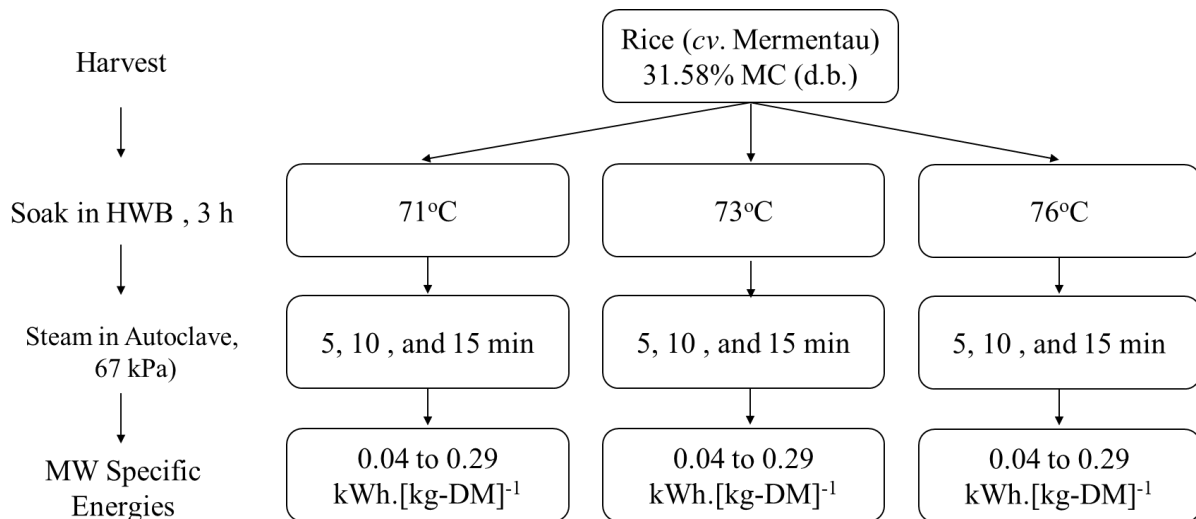

Figure 2.2: Overall experimental process flow diagram; cv., HWB, MW, and MC indicates Cultivar, Hot Water Bath, Microwave and Moisture Content respectively; kg-DM indicates kg of dry matter; d.b. indicates dry basis.

Rice Milling

Triplicate, 150 g subsamples of parboiled rough rice, obtained from each sample dried to 14.29% MC, were dehulled using a laboratory huller (Satake Rice Machine, Satake Engineering Co., Ltd., Tokyo, Japan), milled for 30 s using a laboratory mill (McGill #2 Rice Mill, RAPSCO, Brookshire, TX) and aspirated for 30 s using a seed blower (South Dakota Seed Blower, Seedboro,

Chicago, IL). MRY was calculated as the mass proportion of parboiled rough rice that remains, including head rice and broken, after milling. Head rice was then separated from broken kernels using a double tray sizing machine (Grainman Machinery Manufacturing Corp., Miami, FL). Head rice are considered as kernels that remain at least three-fourths of the original kernel length after complete milling (USDA-GIPSA 2010). HRY was calculated as the mass proportion of parboiled rough rice that remains as head rice after complete milling.

Crude Protein Determination

Crude protein was measured by scanning 50 g of milled rice kernels using NIR reflectance (NIR, DA7200, Perten Instrument, Hagersten, Sweden) following the AACCI Approved Method (39-25.01) for whole-grain. Before the NIR analysis, the instrument was calibrated using the AACCI Approved Method 46-16.01 (Grigg et al., 2016). The resulting equation for calibration is shown in equation 1:

$$CP = 0.747 \times CP_{NIR} + 1.893 \quad (1)$$

where CP denotes crude protein content using an approved method, CP_{NIR} denotes crude protein determined using the NIR method. The crude protein was reported as a mass percentage of protein in wet basis relative to the mass of white rice (Grigg et al., 2016).

Surface lipid content determination

Head rice surface lipid content, also known as fat content, was determined as an indicator of the degree of milling (DOM) using the previously described NIR system. The NIR was calibrated with AACCI Approved Method 30-25.01, and the resulting calibration curve is presented in equation 2 (Matsler & Siebenmorgen, 2005; Saleh et al., 2008):

$$SLC = 0.871 \times SLC_{NIR} - 0.092 \quad (2)$$

Where SLC is surface lipid content (%), and SLC_{NIR} is surface lipid content (NIR method).

Determination of Color Values

The milled rice color indices (L^* , a^* , and b^*) were measured using a colorimeter (Hunter Associates Laboratory, Reston, VA). This was done by placing the measuring arm of the hand-held equipment in contact with and on top of the milled head rice. Before each test, the colorimeter was calibrated using a reference white plate provided by the manufacturer. The instrument measures color indices specified by the International Commission on Illumination (CIE). The parameters L^* describes the lightness from 100 (light) to 0 (dark), parameter a^* describes red-green color with $+a^*$ values for redness and $-a^*$ values for greenness, and parameter b^* indicates yellow-blue color with $+b^*$ values for yellowness and $-b^*$ values for blueness. The a^* and b^* parameters are chromatic components ranging from -120 to 120 (Khir et al., 2014). The total color difference (TCD) (Eqn. 3) is a combination of all the CIE parameters that indicate the TCD of the rice kernel after treatment (Anarjan et al., 2012; Xie et al., 2017; Liu et al., 2019):

$$TCD = \sqrt{(\Delta L^*)^2 + (\Delta a^*)^2 + (\Delta b^*)^2} \quad (3)$$

ΔL^* , Δa^* , and Δb^* represent the difference in L^* , a^* , and b^* values between conventionally- and MW-dried milled rice samples, respectively.

Statistical Analysis

Response surface methodology is a collection of mathematical and statistical techniques based on the fit of a polynomial equation to the experimental data, which must describe the behavior of a data set with the objective of making statistical provisions. It can be well applied when a response or a set of responses of interest are influenced by several variables. By evaluating the responses, the set of operating conditions for making the product with the overall best response was determined. This set of operating conditions is called the optimum condition for the process. The optimum condition for the response is represented by a function. The desirability of response is weighted by an importance value when it is considered against the goals of the other responses during optimization. The importance value is usually set when defining the responses.

Statistical analyses were performed with statistical software (JMP version 15.0.0, SAS Institute). A second order response surface model was used to geometrically describe the relationship between the FMC, MRY, HRY, parboiled milled rice physiochemical properties including the milled rice protein content, surface lipid content and TCD responses and the parameters of MW specific energy, soaking temperature and steaming duration. FMC and HRY were weighted as the most important parameters. Prediction profiler was used to come up with acceptable operation parameters. Overall desirability at recommended parameters were given. Assessment of variable importance was simulated. All tests were considered to be significant when $p < 0.05$.

RESULTS AND DISCUSSION

Implications of Soaking Temperature and Steaming Duration on Moisture Content, Milled Rice

Yield and Head Rice Yield

The least-square means and standard deviations of the control samples' MC, MRY, and HRY after parboiling are presented in Table 2.1.

Table 2.1: Least-square means of the control post-parboiling moisture content, milled rice yield and head rice yield*

		Steaming duration (min)			
		5	10	15	
Soaking Temperature (°C)	71	MC	42.59% ± 0.23%	45.12% ± 0.37%	43.29% ± 0.17%
		MRY	73.87% ± 0.09%	73.53% ± 0.23%	73.49% ± 0.15%
		HRY	73.13% ± 0.66%	73.13% ± 0.78%	73.13% ± 0.32%
	73	MC	44.30% ± 0.47%	46.84% ± 0.20%	45.41% ± 0.13%
		MRY	75.11% ± 0.70%	74.98% ± 0.17%	74.96% ± 0.21%
		HRY	74.07% ± 0.35	74.07% ± .057%	74.07% ± 0.62%
	76	MC	45.62% ± 0.51%	48.21% ± 0.46%	44.53% ± 0.53%
		MRY	72.50% ± 0.03%	72.49% ± 0.15%	72.44% ± 0.27%
		HRY	66.53% ± 0.33%	66.16% ± 1.06%	66.91% ± 0.84%

*MC, MRY, and HRY indicates Moisture Content, Milled Rice Yield, and Head Rice Yield respectively

It can be observed that increasing soaking temperatures from 71 °C to 76 °C caused an increase in rough rice MC before MW treatments. The average MC at soaking temperature of 71 °C was 43.66%, which then increased to 45.52% at 73 °C and then to 46.11% at 76 °C. According to Fickian diffusion, the rate of water diffusion in the direction of flow is proportional to the concentration gradient; the diffusion coefficient is dependent on parameters such as temperature, initial MC, and internal composition of the grain. The major parameter that controlled hydration was temperature. Literature report that when the temperature exceeds the gelatinization

temperature, the water absorption increases significantly (Bakshi and Singh, 1980; Bello et al., 2007).

Increasing soaking temperature from 71 °C to 73 °C caused increases to the MRY and HRY. After increasing temperature from 73 °C to 76 °C, the MRY and HRY decreased. The average MRY and HRY at 71 °C were 73.78% and 73.13%, which then increased to 75.02% and 74.07%, respectively, at 73 °C. At 76 °C, the average MRY and HRY decreased to 72.48% and 66.53%, respectively. Sareepuang et al. (2008) corroborated this trend. They investigated the effect of soaking temperature on the physical, chemical, and cooking properties of parboiled rice. Their results indicate that HRY was significantly increased for parboiled rough rice soaked at water temperatures of 40 °C, 50 °C, and 60 °C to 59%, 83%, and 84%, respectively, from 51% for non-parboiled rough rice samples. Miah et al. (2002) found that the increase in kernel hydration and gelatinization in parboiled rice leads to increases in milling recovery. They suggested that the parboiling process fills the void spaces and cements the cracks inside the endosperm, making the grain harder and minimizing internal fissuring and thereby breakage during milling. Saif et al. (2004) who looked at the effects of processing conditions and environmental exposure on the tensile properties of parboiled rice, reported that the parboiling process induces an increase in length, width and thickness leading to the strengthening of kernel integrity and increase of milling recovery. Soponronnarit et al. (2006), in a study of parboiling of brown rice using superheated steam fluidization, found that the gelatinization process induced by increased soaking temperatures lead to stronger rice starch structure which in turn caused the improvement of HRY.

Increasing steaming duration from 5 to 10 mins caused increases to the MC before MW treatments. After increasing the steaming duration from 10 to 15 min, the MC before MW treatments decreased. The average MC at the 5 min steaming duration was 44.15%, which then

increased to 46.71% at the 10 min steaming duration. The MC then decreased to 44.40% at the 15 min steaming duration. This trend was also supported by Islam, Shimizu, & Kimura (2002), who sought to investigate the effect of processing conditions on the physical properties of parboiled rice. Their investigation found that an increase in MC of rice was correlated with increasing steaming duration from 10 to 60 min. However, they noted that the MC hardly exceeded 53.85% and that at steaming durations above 20 min, there was observable husk splitting.

Increasing steaming duration from 5 to 15 min caused slight decreases in MRY. The average MRY at the 5 min steaming duration was 73.83%, which then decreased to 73.67% at the 10 min steaming duration. At 15 min, the average MRY decreased further to 73.63%. Increasing steaming duration from 5 to 10 mins caused decreases to the HRY. After increasing the steaming duration from 10 to 15 min, the HRY increased slightly. The average HRY at 5 min was 71.24%, which then decreased to 71.12% at 10 min. At 15 min the average HRY increased to 71.37%. Taghinezhad et al. (2015), in their research to investigate the effect of increasing steaming duration from 2 to 10 min on the quality of parboiled Iranian rough rice, found that milling yields significantly increased at the steaming duration of 4, 8 and 6 min. Steaming durations of 1 and 10 min exhibited a significant decrease. They concluded that there exists an optimal steaming duration that increased the milling yields of parboiled rice. They explained that at this optimum steaming duration, gelatinization occurs, leading to stronger kernel structure.

Implications of Soaking Temperature and Steaming Duration on Protein Content, Surface Lipid Content and Total Color Difference

The least-square mean SLC, protein content, TCD of control samples, and their standard deviations are presented in Table 22.

Table 2.2: The least-square means of the control sample protein content, surface lipid content and total color difference*

		Steaming Duration (min)			
		5	10	15	
Soaking Temperature (°C)	71	Protein	6.78% ± 0.25%	7.34% ± 0.20%	6.14% ± 0.82%
		SLC	0.88% ± 0.04%	0.97% ± 0.11%	0.83% ± 0.11%
		TCD	3.00 ± 0.26	3.66 ± 0.04	3.11 ± 0.41
	73	Protein	6.84% ± 0.25%	6.31% ± 0.40%	6.25% ± 1.07%
		SLC	0.66% ± 0.11%	0.66% ± 0.10%	0.62% ± 0.04%
		TCD	3.15 ± 0.61	1.33 ± 0.45	2.28 ± 2.37
	76	Protein	6.07% ± 0.38%	5.82% ± 0.17%	5.86% ± 0.09%
		SLC	0.36% ± 0.04%	0.34% ± 0.04%	0.33% ± 0.02%
		TCD	5.82 ± 0.04	5.39 ± 0.08	4.95 ± 0.06

*SLC = Surface Lipid Content; TCD = Total Color Difference

Increasing soaking temperature from 71 °C to 73 °C caused decreases in protein content. The average protein content at 71 °C was 6.75%, which then decreased to 6.47% at 73 °C soaking temperature. At 76 °C soaking temperature, the average protein content decreased further to 5.92%. The observed trends for protein content can be explained by research conducted by Otegbayo et al. (2001), who studied the effect of parboiling on the physicochemical qualities of two local rice varieties in Nigeria. They found that when comparing parboiled and non-parboiled samples, the parboiled samples showed a decrease in protein content. They explained that this was due to the leaching of protein substances during soaking. Paiva et al., (2016) also reported a decrease in the protein content of both parboiled unpolished black rice and parboiled unpolished red rice when compared to their respective non-parboiled unpolished rice, indicating that parboiling process promoted the leaching of proteins from the grains to the soaking water. Ituen and Ukpakha (2011) reported that the parboiling process leads to the disintegration of protein bodies in the endosperm. Ibukun (2008) reported that the harsher the parboiling treatment, the lower the protein content, and

this might be due to the leaching out of non-protein nitrogen. This indicates that the broken-down protein molecules may still be available in forms other than crude protein that may still provide nutrition.

Increasing soaking temperature from 71 °C to 73 °C caused decreases in SLC. The average SLC at 71 °C was 0.89%, which then decreased to 0.65% at 73 °C soaking temperature. At 76 °C soaking temperature, the average SLC decreased to 0.34%. Kato et al. (1983) evaluated the influence of parboiling on the volatiles of cooked rice of Japonica and Indica rice varieties. Their research indicates that parboiling resulted in a decrease of unbound lipid and free fatty acids in milled rice.

Increasing soaking temperature from 71 °C to 73 °C caused decreases in TCD. The average TCD at 71 °C was 3.26, which then decreased to 2.25 at 73 °C soaking temperature. At 76 °C soaking temperature, the average TCD increased to 5.39. This result agreed with results seen in literature, which states that increased processing of rough rice during parboiling often causes increased changes in TCD (Yousaf et al., 2017).

Increasing steaming duration from 5 to 15 mins caused decreases in protein content. The average protein content at the 5 min steaming duration was 6.56%, which then decreased to 6.49% after 10 min of steaming. At 15 min of steaming, the average protein content decreased to 6.08%. Otegbayo et al. (2001), who researched the effect of parboiling, found that parboiled samples showed a decrease in protein content when compared to non-parboiled samples. They explained that this is due to the protein molecules rupturing during increased steaming. However, the broken-down protein molecules may still be available in forms other than crude protein that may still provide nutrition.

Increasing the steaming duration from 5 to 15 mins caused decreases in TCD. The average

TCD at 5 min steaming duration was 3.99, which then decreased to 3.46 after 10 min of steaming. At 15 min of steaming, the average TCD decreased to 3.45. This result was the opposite of results seen in literature, which states that increased processing of rough rice during parboiling often causes increased changes in TCD (Yousaf et al., 2017). Many researchers measured the changes in color value due to parboiling treatment (Bhattacharya, 1996; Bhattacharya & Subba Rao, 1966; Kimura et al., 1993; Pillaiyar & Mohandoss, 1981). They reported that as soaking temperatures and steaming durations increased, parboiled rice samples became darker. However, it should be noted that steaming durations present in these literatures were often longer than 15 minutes. Bhattacharya (1996) used steaming durations up to 60 mins and Kimura et al. (1993) used steaming durations up to 30 mins. Kimura et al. (1993) reported an increase in lightness of rice as steaming durations increased to 15 mins (for rice soaked at 130 °C) after which the lightness declined. It could be possible that this trend of increased discoloration with increased steaming duration was not seen in this research because the steaming durations were not long enough.

Increasing steaming duration from 5 to 10 mins caused increases to the SLC. After increasing steaming duration from 10 to 15 min, the SLC began to decrease. The average SLC at the 5 min steaming duration was 0.63%, which then increased to 0.66% at 10 min of steaming. The SLC then decreased to 0.59% at 15 min of steaming. Fonseca et al. (2014) reported in their research to evaluate the effect of combinations of soaking temperature and time during the parboiling on the physicochemical and sensory quality of two upland rice cultivars (BRS Primavera and BRS Sertaneja) that fat content increased by 83.3% after 10 min of steaming. The authors reported that the increase of fat content indicates that the water-soluble minerals from bran layer migrated into rice endosperm due to gelatinization during steaming process.

Implications of Microwave Specific Energy, Soaking Temperature and Steam Duration on Physicochemical and Milling Characteristics

The MRY parameter was removed from the analysis because the variance of the MRY response data was too large and led to statistical insignificance of the entire model. Table 2.3 shows the effect summary table for the FMC and HRY responses. The table list the model effects. Smaller p-values indicate higher significance to the model.

The effect summary table indicates high statistical significance ($p < 0.05$) for the main effects (MW specific energy, soaking temperature and steaming duration) for the FMC response. There was also a quadratic effect in the model (soaking temperature*soaking temperature). This means that if the relationship between the FMC response and the parameter of MW specific energy were represented by a graph, the optimal response will not be at the extremes of the experimental region but inside it.

The effect summary table also indicates high statistical significance ($p < 0.05$) for the main effect of soaking temperature and MW specific energy for the HRY response. There were also quadratic effects in the model (soaking temperature*soaking temperature, and MW specific energy*MW specific energy). This means that if the relationship between the HRY response and the parameters of soaking temperature and MW specific energy were represented by a graph, the optimal response will not be at the extremes of the experimental region but inside it. There was also a statistically significant interaction between the soaking temperature and the MW specific energy ($p = 0.03913$). This means that both soaking temperature and the MW specific energy aided in the reduction of the HRY.

Table 2.3 shows the effect summary table for the protein content, SLC and TCD responses. The table list the model effects. Smaller p-values indicate higher significance to the model.

The effect summary table indicates high statistical significance ($p < 0.05$) for the main effects (MW specific energy, soaking temperature and steaming duration) for the protein content response. There were also quadratic effects in the model (soaking temperature*soaking temperature and MW specific energy*MW specific energy). This means that if the relationship between the protein content response and the parameters of MW specific energy and soaking temperature were represented by a graph, the optimal responses will not be at the extremes of the experimental region but inside it.

The effect summary table indicates high statistical significance ($p < 0.05$) for the main effect of soaking temperature for the SLC response. There were also quadratic effects in the model (soaking temperature*soaking temperature, steam duration*steam duration, and MW specific energy*MW specific energy). This means that if the relationship between the SLC response and the parameters of soaking temperature, MW specific energy and steaming duration were represented by a graph, the optimal responses will not be at the extremes of the experimental region but inside it. There was also a statistically significant interaction between the soaking temperature and the steaming duration ($p = 0.03455$). This means that both soaking temperature and the steaming duration aided in the reduction of the SLC.

The effect summary table indicates high statistical significance ($p < 0.05$) for the main effect of soaking temperature, MW specific energy and steaming duration for TCD. There were also quadratic effects in the model (soaking temperature*soaking temperature and MW specific energy*MW specific energy). This means that if the relationship between the TCD response and the parameters of soaking temperature and MW specific energy were represented by a graph, the optimal responses will not be at the extremes of the experimental region but inside it. There was also a statistically significant interaction between the soaking temperature and the steaming

duration ($p = 0.04575$). This means that both soaking temperature and the steaming duration aided in the increase of the TCD. There was also a statistically significant interaction between the soaking temperature and the MW specific energy ($p = 0.04575$). This means that both soaking temperature and the MW specific energy also aided in the increase of the TCD.

Table 2.3: Effect summary table showing the effects of microwave specific energy, soaking temperature and steam duration on final moisture content, head rice yield, protein content, surface lipid content and total color difference*

Response	Source	<i>p</i> -value
FMC (% d.b)	X1	0.00000
	X2*X2	0.00000
	X2	0.00026
	X3	0.04917
HRY (%)	X2	0.00000
	X2*X2	0.00000
	X1	0.00003
	X1*X1	0.00025
	X2*X1	0.03913
Protein Content (%)	X1	0.00000
	X2*X2	0.00000
	X2	0.00000
	X1*X1	0.00029
	X3	0.03552
SLC (%)	X2	0.00000
	X2*X2	0.00000
	X1*X1	0.00724
	X2*X3	0.03455
	X3*X3	0.04968
TCD	X2	0.00000
	X1*X1	0.00001
	X2*X1	0.00114
	X1	0.00896
	X3	0.01226
	X2*X2	0.03173
	X2*X3	0.04575

*FMC = Final Moisture Content; HRY = Head Rice Yield; SLC = Surface Lipid Content; TCD = Total Color Difference; X1 = MW Specific Energy (kWh.[kg-DM]⁻¹); X2 = Soaking Temperature (°C); X3 = Steam Duration (min)

Table 2.4 shows the summary of fit table for the FMC, HRY, Protein content, SLC and

TCD parameters. This table shows the R-Square, adjusted R-Square, root mean square error and p -Values for those responses. R-square is a statistical measure that represents the proportion of the variance for a dependent variable that is explained by an independent variable or variables in a regression model. The adjusted R-square is a modified version of R-square that has been adjusted for the number of predictors in the model. Root mean square error is an estimate of standard deviation of the model. A low R-square value is most problematic when reasonably precise predictions are needed. Although a high R-square value is usually preferred as it provides an estimate of the strength of the relationship between the model and the response variable, it does not give a formal hypothesis test for this relationship. The F-test of overall significance determines whether this relationship is statistically significant as indicated by the p -value.

The R-square error for the FMC response was 0.918359. This means that the fitted model respectively explains 91.84% of the variation in the FMC response. There was high statistical significance as indicated by the p -value ($<.0001$). The R-square error for the HRY response was 0.750269. This means that the fitted model respectively explains 75.03% of the variation in the HRY response. There was high statistical significance as indicated by the p -value ($<.0001$). The R-square error for the protein content response was 0.755237. This means that the fitted model respectively explains 75.52% of the variation in the protein content response. There was high statistical significance as indicated by the p -value ($<.0001$). The R-square error for the SLC response was 0.758838. This means that the fitted model respectively explains 75.88% of the variation in the SLC response. There was high statistical significance as indicated by the p -value ($<.0001$). The R-square error for the TCD response was 0.419705. This means that the fitted model respectively explains 41.97% of the variation in the TCD response. There was high statistical significance as indicated by the p -value ($<.0001$).

Table 2.4: Summary of fit table for the final moisture content, head rice yield, protein content, surface lipid content and total color difference responses*

Response	R-Square	Adjusted R-Square	Root Mean Square Error	p-value
FMC (% d.b)	0.918359	0.913648	2.022007	<.0001
HRY (%)	0.750269	0.726358	2.554543	<.0001
Protein Content (%)	0.755237	0.735391	0.350042	<.0001
SLC (%)	0.758838	0.739284	0.118517	<.0001
TCD	0.419705	0.371347	1.334137	<.0001

*FMC = Final Moisture Content; HRY – Head Rice Yield; SLC = Surface Lipid Content; TCD = Total Color Difference; d.b = dry basis

Figure 2.3 shows the variable importance report for the overall, FMC, SLC, TCD, protein content and HRY responses. The variable importance report calculates indices that measure the importance of parameters in a model in a way that is independent of the model type and fitting method. This report estimates the variability in the predicted response based on a range of variation for each parameter. If variation in the parameter causes high variability in the response, then that effect is important relative to the model.

The report indicates that the soaking temperature parameter was most important followed by MW specific energy then steaming duration for the overall model, the SLC, the protein content and the HRY responses. The parameters' (soaking temperature, MW specific energy and steaming duration) main effects were (0.557, 0.353, 0.017), (0.937, 0.018, 0.013), (0.696, 0.248, 0.015) and (0.83, 0.112, 0.017) for the overall model, the SLC, the protein content and the HRY responses respectively. These main effects contributed the most to the total effects (0.616, 0.402, 0.037), (0.959, 0.028, 0.023), (0.716, 0.268, 0.026) and (0.858, 0.138, 0.029) for the overall model, the SLC, the protein content and the HRY responses, respectively.

The MW specific energy parameter was most important followed by soaking temperature then steaming duration for the FMC and the TCD responses. The parameters' (MW specific

energy, soaking temperature and steaming duration) main effects were (0.968, 0.007, 0.002) and (0.418, 0.315, 0.035). These main effects contributed the most to the total effects (0.985, 0.011, 0.003) and (0.589, 0.537, 0.103) for the FMC and the TCD responses, respectively.

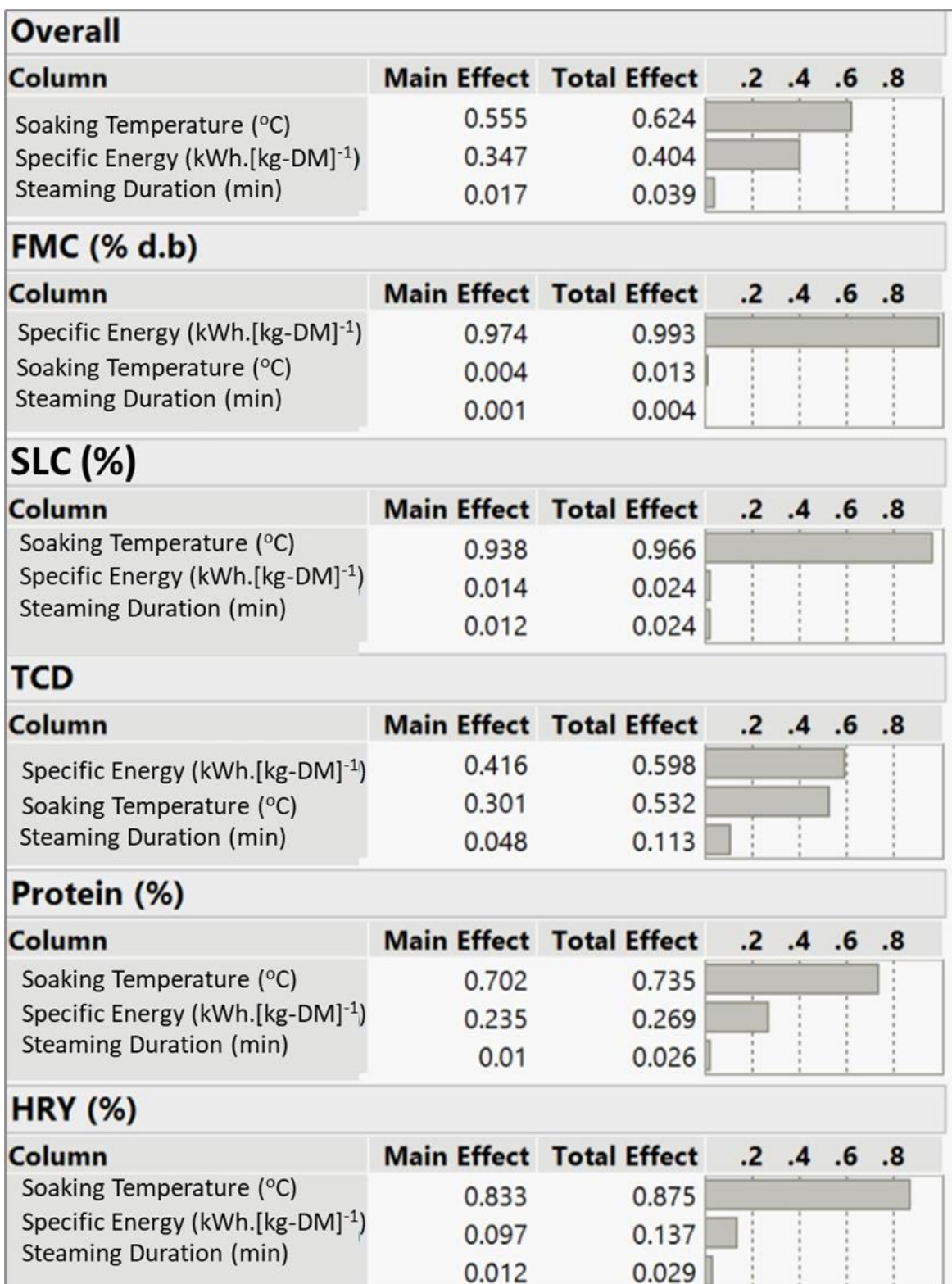

Figure 2.3: The variable importance report for the overall, final moisture content, surface lipid content, total color difference, protein content and head rice yield responses; FMC = Final Moisture Content; HRY – Head Rice Yield; SLC = Surface Lipid Content; TCD = Total Color Difference; MW = MW; d.b = dry basis; kg-DM = kg of dry matter

The implications of MW specific energy, steaming duration and soaking temperature on the rice FMC and HRY are graphically displayed in Figure 2.4. The overall shape of the graph indicates that the FMC decreased with an increasing MW specific energy. The lowest FMCs were seen at the MW specific energy of $0.29 \text{ kWh} \cdot [\text{kg-DM}]^{-1}$. At this MW specific energy, the FMC response had the least mean square of 18.24% and a standard deviation of 0.89% ($SD \pm 0.89\%$). This FMC is 2.62 percentage points higher than the MC range necessary for safe storage conditions (14.29 to 15.61%). The trend of decreasing FMC as a result of increasing MW specific energy was also seen in a study by Smith & Atungulu, (2018) whose objective was to dry freshly-harvested rough rice using a 915 MHz MW. The researchers found that increasing MW specific energy led to corresponding increases in rice final surface temperature, which, congruently, lead to decreases in rice FMC, HRY, and MRY.

It is noticeable that the FMC of samples that were soaked at 71, 73, and 76 °C makes a downward “U-shape” with that of the 73 °C soaking temperature having the highest FMC. The lowest FMC was seen for samples soaked at 76 °C. The average MC of the rough rice samples after soaking at temperatures of 71 °C, 73 °C, and 76 °C followed by steaming was 43.66%, 45.52% and 46.11%, respectively. The FMC of the samples after drying with MW at the specific energy of $0.29 \text{ kWh} \cdot [\text{kg-DM}]^{-1}$ MW had least mean squares of 17.38%, 20.03% and 17.32% ($SD \pm 0.50\%$, 1.07% and 1.09%) for the 71, 73, and 76 °C soaking temperatures, respectively. These trends could be explained by gelatinization of the rice starch during the process of treatments. The gelatinization point of rice starch is the temperature at which further hydration and irreversible starch granule swelling take place and is specific for each rice cultivar (Ali and Ohja, 1976; Chattopadhyay and Kunze, 1986). Igathinathane et al. (2005) determined the gelatinization temperature of rice starch and found that soaking rough rice above the gelatinization temperature caused rapid and excessive

moisture absorption. Conversely, soaking at temperatures below the gelatinization temperature was found to increase the time for the raw rough rice to reach saturation MC; however, desirable milled rice characteristics and reduced chalky kernels were maintained. This was corroborated by Mir & Bosco (2013), who stated that the higher the parboiling temperature, the higher the rate of water absorption. However, Sareepuang et al. (2008), who investigated the effect of soaking temperature on the physical properties of parboiled rice, found that increased soaking temperatures caused decreases in protein content. The reduction in protein content can explain the decrease in MC at soaking temperatures of 76 °C. While there is expected to be an increase in MC as soaking temperatures increased from 71 °C to 76 °C, an apparent decrease in MC can be explained by a simultaneous decrease in protein content. MCs for this experiment were taken gravimetrically, and therefore, a decrease in protein content could alter the mass of the parboiled rough rice, which can erroneously be translated to a decrease in MC.

As MW specific energy increased, the HRY increased to a peak response at 0.15 kWh.[kg-DM]⁻¹ (Fig. 2.4). At this MW specific energy, milled rice samples had the least-square means of 69.76% (SD ± 2.44%). After which the HRY decreased to its lowest point at 0.29 kWh.[kg-DM]⁻¹ with an HRY of 66.67% (SD ± 4.72%). This reduction can be attributed to increasing MW specific energy. Higher MW specific energies have been shown to induce higher surface temperatures. High-temperature drying is known to lead to the formation of fissures. The presence of fissures on a rice kernel makes it more susceptible to breakage during subsequent hulling and milling processes (Smith & Atungulu, 2018).

When compared to control samples, there was a noticeable decrease in HRY for samples treated with MW. The average HRY for control samples soaked at 71 °C was 73.13%, which then increased to 74.07% at 73 °C. For samples soaked at 76 °C, the average HRY decreased to 66.53%.

Upon drying of parboiled rough rice soaked at temperatures of 71 °C, 73 °C, and 76 °C with MW at specific energy of 0.29 kWh.[kg-DM]⁻¹, the HRY least-square were 66.84% (SD ± 2.57%), 72.56% (SD ± 0.66%) and 59.80% (SD ± 2.93%) respectively (Fig. 2.4). The HRY is often the most critical quality parameter to rice millers since the HRY is linked to payment received for rice delivered at milling facilities. Under ideal conditions, a perfect HRY recovery would be about 70% of the total rough rice produced after the rice hulls and bran are removed. However, with current conventional rice drying methods, HRY recovery in controlled laboratory experiments averages only about 58% and can be even lower depending on other pre-harvest and post-harvest factors (USDA, 2014; Atungulu et al. 2016).

Igathinathane et al. (2005) determined that soaking rough rice above the gelatinization temperature may cause quality concerns because of husk splitting and that soaking at temperatures below the gelatinization temperature was found to maintain desirable rice quality. This indicates that there exists an optimum soaking temperature for rice cultivars. In the case of the cultivar that was used for this experiment (Mermentau), it could be inferred that the optimum soaking temperature exists at 73 °C.

When compared to rough rice samples that were not treated with MW, there was a noticeable decrease in MC when samples were treated with MW. The average MC of the rough rice samples after 5 min steaming duration was 44.15%, which then increased to 46.71% at the 10 min steaming duration. The MC then decreased to 44.40% at the 15 min steaming duration. At 0.29 kWh.[kg-DM]⁻¹ the FMC least-square means were 19.33%, 19.43% and 16.51% (SD ± 1.70%, 1.17% and 0.21%) for the 5, 10, and 15 min steaming duration. It is known that the condensation from the steaming process adds water and increases the MC of paddy before drying. Steaming is the preferred heating method for parboiling because of this fact. By increasing the MC

before the MW drying process, it is to be expected that increased steaming would lead to increases in the rice FMC.

When compared to milled rice samples that were not treated with MW, there was a noticeable decrease in HRY when samples were treated with MW. The average HRY of the milled rice samples after the 5 min steaming duration was 71.24%, which then decreased to 71.12% at 10 min. At 15 min the average HRY increased to 71.37%. At 0.29 kWh.[kg-DM]⁻¹, the HRY least-square means were 68.62%, 63.79% and 66.23% (SD ± 3.578%, 4.58% and 1.67%) for the 5, 10, and 15 min steaming duration.

The implications of MW specific energy, steaming duration and soaking temperature on the on the milled rice SLC, protein content, and TCD are graphically displayed in Figure 2.4. The highest SLC was seen at specific energies of 0.04 kWh.[kg-DM]⁻¹ and had the least-square means of 0.88%, 0.76% and 0.33% (SD ± 0.03%, 0.07% and 0.05%) for the 71, 73, and 76 °C soaking temperatures respectively. Additionally, when compared to milled rice samples that were not treated with MW there was a noticeable decrease. The average SLC of the rough rice samples after soaking at temperatures of 71 °C, 73 °C, and 76 °C followed by steaming was 0.89%, 0.65% and 0.34%, respectively. At 0.29 kWh.[kg-DM]⁻¹ the SLC least-square means were 0.87%, 0.75% and 0.28% (SD ± 0.04%, 0.15% and 0.02%) for the 71, 73, and 76 °C soaking temperatures, respectively. SLC is the mass percentage of lipids remaining on the surface of a rice kernel after milling. SLC affects the stability, quality, appearance, and end-use functionality of rice (Chen et al. 1997). The majority of the lipids of rice are concentrated in the bran, making it subject to rancidification. As a result, bran is often separated from the rice kernel before storage in a process called milling. As milling progresses, the DOM is said to increase, and the SLC decreases (Hogan and Deobald, 1961; Pomeranz et al. 1975; Miller et al. 1979). Consequently, rice SLC is often

used as a parameter to indicate DOM. Industrial milling practice for rough rice targets a DOM that has a resultant SLC of 0.4% for optimal HRY recovery and better storability. However, milling equipment is metered to obtain this SLC based on characteristics of rice dried using conventional drying methods. An excessively high SLC for rice kernels dried using MW indicates considerable kernel hardening resulting in less surface lipid being removed after milling. This result is congruent with past research that indicates that the DOM decreases due to the hardening of the rice kernels (Inprasit & Noomhorm, 2001; Smith et al., 2018). This data indicates that it is necessary to reconsider milling durations that give similar SLC for MW drying operations.

When compared to parboiled milled rice samples that were not treated with MW there was a noticeable decrease in protein content when samples were treated with MW. The average protein content of the milled rice samples after soaking at temperatures of 71 °C, 73 °C, and 76 °C followed by steaming was 6.75%, which then decreased to 6.47% at 73 °C soaking temperature. At 76 °C soaking temperature, the average protein content decreased to 5.92%. At MW treatment with specific energy of 0.29 kWh.[kg-DM]⁻¹ the protein content's least-square means were 5.98%, 6.30% and 4.96% (SD ± 0.45%, 0.46% and 0.22%) for the 71, 73, and 76 °C soaking temperatures, respectively. Protein fractions, known as starch granule-associated proteins (SGAPs), left on the rice kernel after the milling processes have been shown to influence endosperm texture, and gelatinization and pasting properties of the rice starch (Greenwell & Schofield, 1986; Morrison, Greenwell, Law, & Sulaiman, 1992; Hamaker & Griffin, 1993). During the process of drying, denaturation, and changes in the functionality of the rice proteins can take place, that may influence overall rice quality. Heat treatments induce non-covalent hydrophobic interactions and intermolecular disulfide crosslinks that denature proteins and contribute to their insolubilization (Odjo et al. 2015). Research on rice proteins extracted from defatted rice flour suggests that the

two major rice proteins (globulin and glutelin) progressively denatured upon heat treatments from 45 °C to 80 °C for 10 min and leveled off from 80 °C to 95 °C for 10 min (Ju, Hettiarachchy & Rath, 2001). The high energy fluxes associated with MW are capable of heating rice to surface temperatures over 120 °C (Atungulu et al., 2016). Increasing specific energies resulted in increasing final surface temperatures and consequently could have an increase in the denaturation of rice proteins (Smith et al., 2018). Increasing soaking temperatures could also influence the denaturation of proteins in the parboiled milled rice samples. Sareepuang et al. (2008) investigated the effect of soaking temperature on physical, chemical and cooking properties of parboiled rice and found that soaking rough rice samples at 40, 50 and 60 °C for 3 h resulted in an initial increase in protein content as soaking temperature increased from 40 °C to 50 °C, upon further heating the protein content decreased as soaking temperature increased from 50 °C to 60 °C. This indicates that there exists an optimum soaking temperature for rice parboiling that can be cultivar dependent.

When compared to milled rice samples that were not treated with MW, there was a noticeable increase in TCD when samples were treated with MW. The average TCD of the milled rice samples after soaking at temperatures of 71 °C was 3.26, which then decreased to 2.25 at 73 °C soaking temperature. At 76 °C soaking temperature, the average TCD increased to 5.39. Treatment with MW at specific energy of 0.29 kWh.[kg-DM]⁻¹ resulted in TCD least-square means of 5.05, 2.73 and 6.03 (SD ± 1.05, 1.25 and 3.46) for samples soaked at temperatures of 71, 73, and 76 °C, respectively.

When compared to milled rice samples that were not treated with MW, there was a noticeable increase in SLC when samples were treated with MW. The average SLC of the milled rice samples after the 5 min steaming duration was 0.63%, which then increased to 0.66% at 10 min of steaming. The SLC then decreased to 0.59% at 15 min of steaming. At 0.29 kWh.[kg-DM]⁻¹

¹, the least-square means of the SLC were 0.64%, 0.71% and 0.68% (SD \pm 0.03%, 0.03% and 0.04%) for the 5, 10, and 15 min steaming duration.

When compared to milled rice samples that were not treated with MW, there was a noticeable decrease in protein content when samples were treated with MW. The average protein content of the milled rice samples after the 5 min steaming duration was 6.56%, which then decreased to 6.49% after 10 min of steaming. At 15 min of steaming, the average protein content decreased to 6.08%. At 0.29 kWh.[kg-DM]⁻¹, the least-square means of the protein content were 5.65%, 6.25% and 4.87% (SD \pm 0.47%, 0.45% and 0.43%) for the 5, 10, and 15 min steaming duration.

When compared to milled rice samples that were not treated with MW, there was a noticeable decrease in TCD when samples were treated with MW. The average TCD of the milled rice samples after the 5 min steaming duration was 3.99, which then decreased to 3.46 after 10 min of steaming. At 15 min of steaming, the average TCD decreased to 3.45. At 0.29 kWh.[kg-DM]⁻¹, the least-square means of the TCD were 2.62, 2.82, and 3.31 (SD \pm 0.24, 0.24 and 0.25) for the 5, 10, and 15 min steaming duration.

Prediction profiler was used to set desirability goals, which in this study was to maximize HRY, protein content and SLC and to minimize the FMC and TCD. This was done to find optimal settings for the parameters of MW specific energy, soaking temperature, and steaming duration. Of the possible MW specific energies (0.04 to 0.29 kWh.[kg-DM]⁻¹), soaking temperatures (71 °C, 73 °C and 76 °C) and steaming durations (5, 10 and 15 mins) it was determined that maximum HRY, protein content and SLC and minimum FMC and TCD is obtained at parameter settings of 73 °C soaking temperature, MW specific energy of 0.29 kWh.[kg-DM]⁻¹ and a steaming duration of 10 mins according to the prediction profile (Figure 2.4). At these parameters optimal FMC,

HRY, protein content, SLC and TCD were 18.79% d.b, 69.33%, 6.02%, 0.81% and 3.93. The prediction profile was colorized based on most important parameter for each response.

In addition to the determination of the optimal parameter levels, the prediction profiler also gives insight to the significance of impact a parameter has on the performance parameter in question. A steep slope indicates that an operational parameter has a significant impact on the given performance parameter, whereas a shallow slope indicates little or no effect on a performance parameter.

The last row of plots shows the desirability trace for each parameter. The numerical value beside the word 'Desirability' on the vertical axis is the geometric mean of the desirability measures. This row of plots shows both the current desirability and the trace of desirability that result from changing one parameter at a time. A desirability of 0.69 indicates that approximately 69.81% of the goals to optimize HRY, protein content, SLC, FMC and TCD responses were reached.

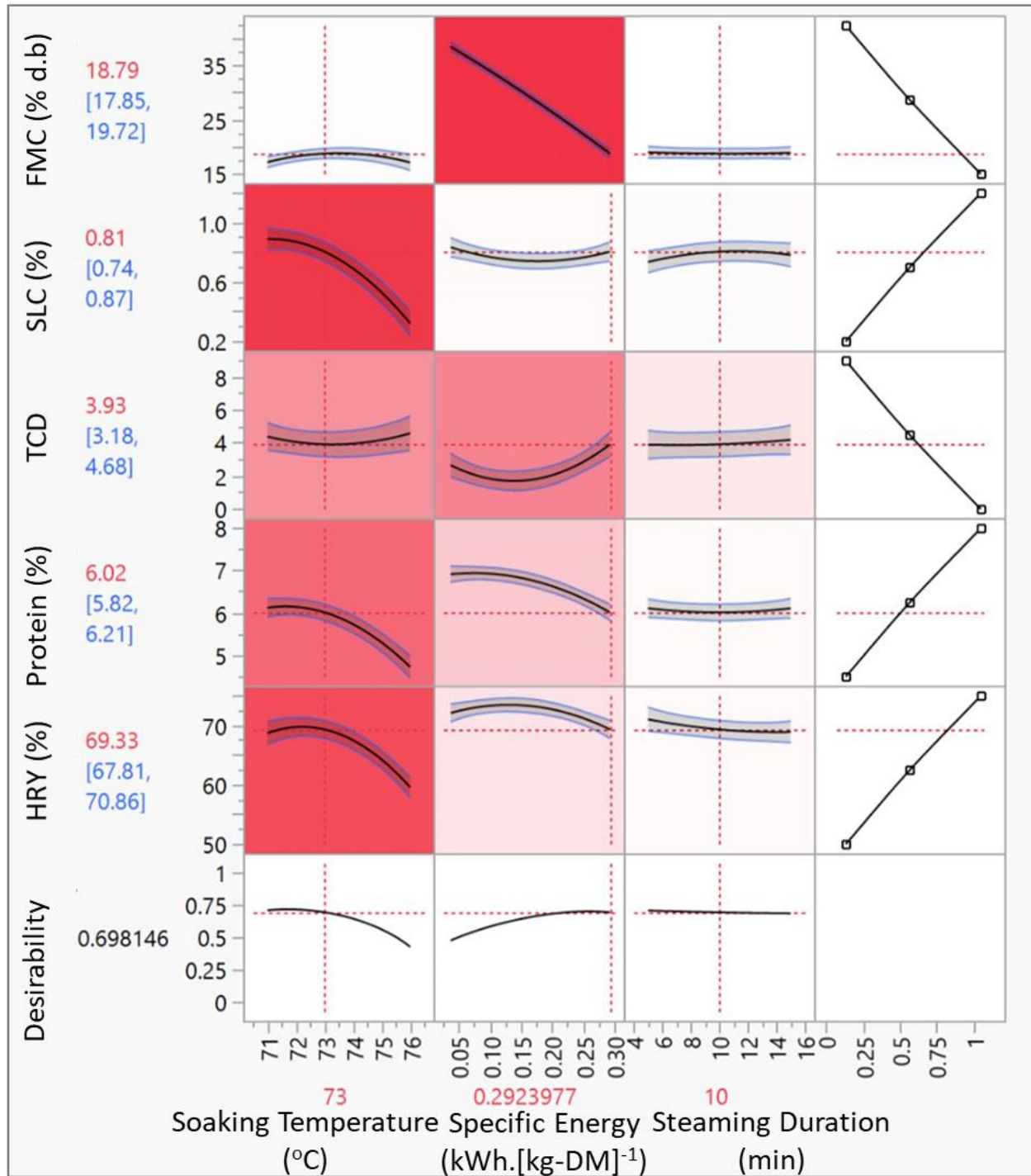

Figure 2.4: Prediction profile for the head rice yield (HRV), protein content, surface lipid content (SLC), final moisture content (FMC) and total color difference (TCD) responses with parameter settings soaking temperature, MW specific energy and steaming duration; kg-DM indicates kg of dry matter

Figure 2.5 shows the contour profiler for the HRY, protein content, SLC, FMC and TCD. A contour profiler shows plots of response contours for multiple factors at a time. An upper limit for FMC and TCD were set as 19.72% and 4.68. A lower limit for HRY, SLC and protein content were set as 67.81%, 0.74% and 5.82. The white unshaded area shows the safe operating region for optimal HRY, protein content, SLC, FMC and TCD. This indicates that the optimized responses for HRY, protein content, SLC, FMC and TCD exists when parameter (factor) settings for soaking temperature, MW specific energy and steaming duration are set to 73 °C, 0.29 kWh.[kg-DM]⁻¹ and 10 mins.

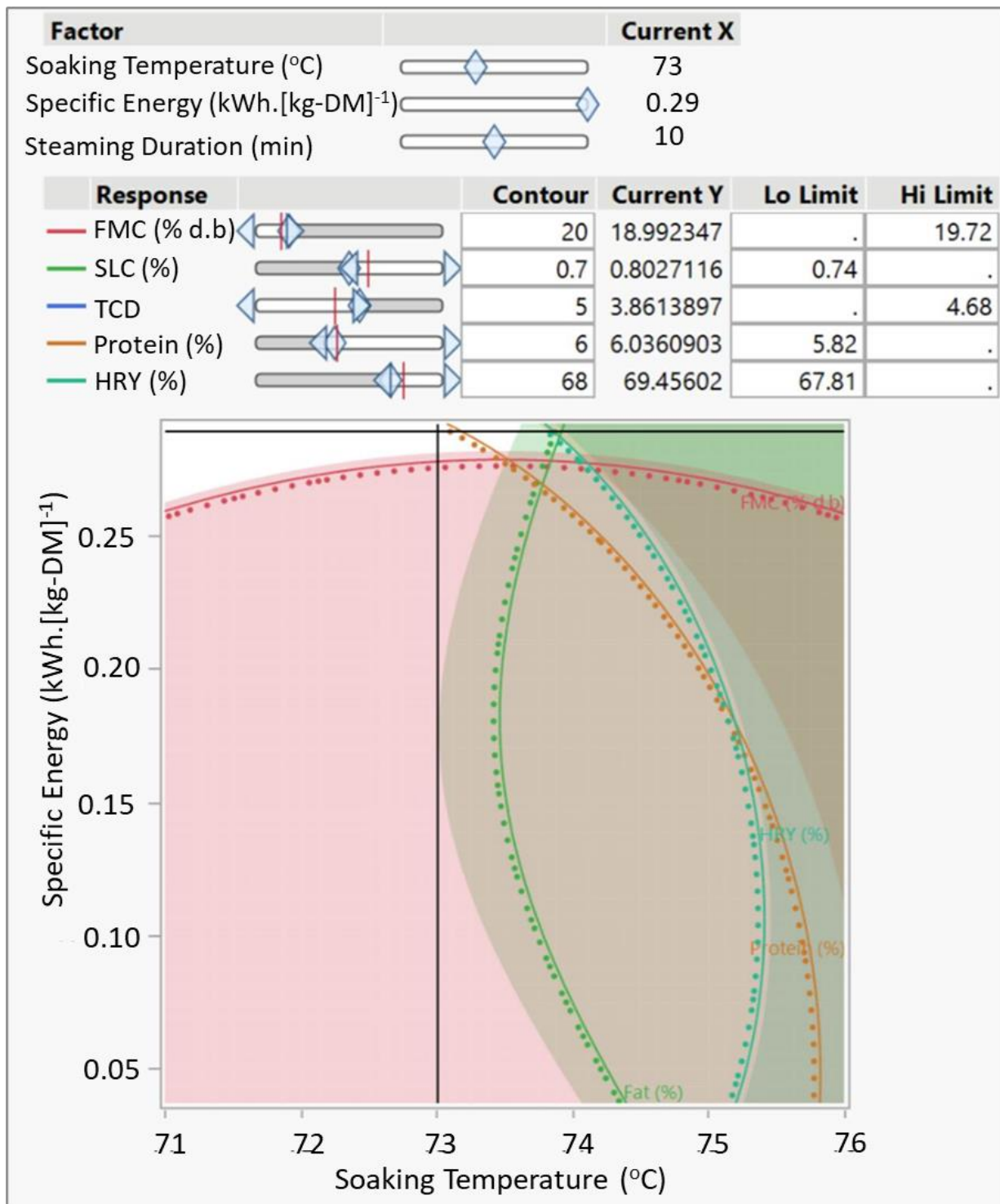

Figure 2.5: Contour Profiler for the head rice yield (HRV), protein content, surface lipid content (SLC), final moisture content (FMC) and total color difference (TCD) responses with parameter settings soaking temperature, MW specific energy and steaming duration; kg-DM indicates kg of dry matter

CONCLUSION

The feasibility of using a MW set at a frequency of 915 MHz to dry high-MC parboiled rough rice was investigated, and the implications of varied steaming and soaking conditions on the parboiled rough rice FMC, milling yield and physicochemical properties were determined. It was found that increasing soaking temperature from 71 °C to 76 °C led to increased uptake of water after parboiling, decreases in MRY, HRY, protein content, and SLC and increased TCD. Increasing steaming duration from 5 to 15 min led to decreased uptake of water by rice after the parboiling process, decreased MRY, protein content, SLC and TCD and increased HRY. Increasing MW specific energy from 0.04 to 0.29 kWh.[kg-DM]⁻¹ led to decreases in FMC, HRY, protein content, and SLC and increased TCD. Based on this research, it is recommended that long-grain rice of cultivar Mermentau is soaked at 73 °C, steamed for 10 min, then treated at MW specific energy of 0.29 kWh.[kg-DM]⁻¹ to achieve rough rice FMC of 18.79%. At this parameter, parboiled rough rice had HRY of 69.33%, and desirable parboiled rough rice physicochemical and sensory properties. It may then be necessary to continue the drying process to the safe storage MC range of 14.29 to 15.61% using natural or hot air.

ACKNOWLEDGEMENTS

This study was based upon work that is supported, in part, by the United States Department of Agriculture National Institute of Food and Agriculture Hatch Act Funding and AMTeK Microwaves.

REFERENCES

- Akhter, M., Ali, M. A., Haider, Z., & Muzammil, S. (2014). Efficacy of parboiling on physico-chemical properties of some promising lines/varieties of rice (*Oryza sativa* L.). *Sci Tech and Dev*, 33(3), 115-122.
- Anarjan, N., Tan, C. P., Nehdi, I. A., & Ling, T. C. (2012). Colloidal astaxanthin: Preparation, characterisation and bioavailability evaluation. *Food chemistry*, 135(3), 1303-1309.
- Atungulu, G. G., Smith, D. L., Wilson, S. A., Zhong, H., Sadaka, S., & Rogers, S. (2016). Assessment of One-Pass Drying of Rough Rice with an Industrial Microwave System on Milling Quality. *Applied Engineering in Agriculture*, 32(3), 417-42.
- Bakshi, A. S., & Singh, R. P. (1980). Kinetics of water diffusion and starch gelatinization during rice parboiling. *Journal of Food Science*, 45(5), 1387-1392.
- Bauer, B. A., & Knorr, D. (2004). Electrical conductivity: a new tool for the determination of high hydrostatic pressure-induced starch gelatinisation. *Innovative Food Science & Emerging Technologies*, 5, 437-442.
- Bello, M. O., Tolaba, M. P., & Suarez, C. (2007). Water absorption and starch gelatinization in whole rice grain during soaking. *LWT – Food Science and Technology*, 40(2), 313-318.
- Bhattacharya, S. (1996). Kinetics on color changes in rice due to parboiling. *Journal of Food Engineering*, 29, 99-106.
- Bhattacharya, K. R., & Subba Rao, P. V. (1966). Effect of processing conditions on quality of parboiled rice. *Journal of Agricultural Food Chemistry*, 14(5), 476-479.
- Chattopadhyay, P. K., & O. R. Kunze. 1986. Fissuring characteristics of parboiled and raw milled rice. *Trans. ASAE* 29(6): 1760-1766.
- Chen, H., Marks, B. P., & Siebenmorgen, T. J. (1997). Quantifying Surface Lipid Content of Milled Rice via Visible/Near-Infrared Spectroscopy. *Cereal chemistry*, 74(6), 826-831.
- Chukwu, O. (1999). Parboiling of rice paddy with heated pebbles. *Journal of Science, Technology and Mathematics Education*, 2(1), 70-76.
- FAO, (1998). Physical activity: Impact of protein and amino metabolism and implication for nutritional requirements. World Health Organization (WHO) Technical Report, Geneva, Ser. No 522.
- FAOSTAT, (2007). FAO Statistical databases. www.fao.org. Food and Agriculture Organization (FAO) of the United Nations, Rome.

- Fonseca, F. A., Soares Júnior, M. S., Bassinello, P. Z., Eifert, E. D. C., Garcia, D. M., & Caliari, M. (2014). Technological, physicochemical and sensory changes of upland rice in soaking step of the parboiling process.
- Greenwell, P., & Schofield, J. D. (1986). A starch granule protein associated with endosperm softness in wheat. *Cereal Chemistry*, 63(4), 379-380.
- Grigg, B. C., Siebenmorgen, T. J., & Norman, R. J. (2016). Effects of nitrogen rate and harvest moisture content on physiochemical properties and milling yields of rice. *Cereal Chemistry*, 93(2), 172-181.
- Hamaker, B. R., & Griffin, V. K. (1993). Effect of disulfide bond-containing protein on rice starch gelatinization and pasting. *Cereal Chemistry*, 70(4), 377-380.
- Hogan, J. T., & Deobald, H. J. (1961). Note on a method of determining the degree of milling of whole milled rice. *Cereal Chem*, 38(3), 291-293.
- Hui, Y. H., & Evranuz, E. Ö. (Eds.). (2015). *Handbook of vegetable preservation and processing*. CRC press.
- Ibukun, E. O. (2008). Effect of prolonged parboiling duration on proximate composition of rice. *Scientific Research and Essays*, 3(7), 323-325.
- Igathinathane, C., Chattopadhyay, P. K., & Pordesimo, L. O. (2005). Combination soaking procedure for rough rice parboiling. *Transactions of the ASAE*, 48(2), 665-671.
- Inprasit, C., & Noomhorm, A. (2001). Effect of drying air temperature and grain temperature of different types of dryer and operation on rice quality. *Drying Technology*, 19(2), 389-404. <https://doi.org/10.1081/DRT-100102912>.
- Islam, M. R., Shimizu, N., & Kimura, T. (2002). Effect of processing conditions on thermal properties of parboiled rice. *Food Science and Technology Research*, 8(2), 131-136.
- Ituen, E. U. U., & Ukpakha, A. C. (2011). Improved method of par-boiling paddy for better quality rice. *World Journal of Applied Science and Technology*, 3, 31-40.
- Jindal, V. K., & Siebenmorgen, T. J. (1987). Effects of oven drying temperature and drying time on rough rice moisture content determination. *Transactions of the ASAE*, 30(4), 1185-1192.
- Ju, Z. Y., Hettiarachchy, N. S., & Rath, N. (2001). Extraction, denaturation and hydrophobic properties of rice flour proteins. *Journal of Food Science*, 66(2), 229-232. <https://doi.org/10.1111/j.1365-2621.2001.tb11322.x>.
- Kato, H., Ohta, T., Tsugita, T., & Hosaka, Y. (1983). Effect of parboiling on texture and flavor components of cooked rice. *Journal of Agricultural and Food Chemistry*, 31(4), 818-823.

- Khair, R., Pan, Z., Thompson, J. F., El-Sayed, A. S., Hartsough, B. R., & El-Amir, M. S. (2014). Moisture removal characteristics of thin layer rough rice under sequenced infrared radiation heating and cooling. *Journal of Food Processing and Preservation*, 38(1), 430-440.
- Koh, E., & Surh, J. (2016). Parboiling improved oxidative stability of milled white rice during one-year storage. *Food science and biotechnology*, 25(4), 1043-1046.
- Liu, Z.L., Bai, J.W., Yang, W.X., Wang, J., Deng, L.Z., Yu, X.L., Zheng, Z.A., Gao, Z.J., Xiao, H.W. (2019). Effect of high-humidity hot air impingement blanching (HHAIB) and drying parameters on drying characteristics and quality of broccoli florets. *Drying Technology*, 37(10), 1251-1264.
- Matsler, A. L., & Siebenmorgen, T. J. (2005). Evaluation of operating conditions for surface lipid extraction from rice using a Soxtec system. *Cereal chemistry*, 82(3), 282-286.
- Miah, M. K., Haque, A., Douglass, M. P., & Clarke, B. (2002). Parboiling of rice. Part I: Effect of hot soaking time on quality of milled rice. *International journal of food science & technology*, 37(5), 527-537.
- Miller, B. S., Lee, M. S., Pomeranz, Y., & Rousser, R. (1979). A rapid, objective method to measure the degree of milling in rice. *Cereal Chemistry*, 56(3), 172-180.
- Mir, S. A., & Bosco, S. J. D. (2013). Effect of soaking temperature on physical and functional properties of parboiled rice cultivars grown in temperate region of India. *Food and Nutrition Sciences*, 4(03), 282.
- Morrison, W. R., Greenwell, P., Law, C. N., & Sulaiman, B. D. (1992). Occurrence of friabilin, a low molecular weight protein associated with grain softness, on starch granules isolated from some wheats and related species. *Journal of Cereal Science*, 15 (2), 143-149.
- Mujumdar, A. S., & Devahastin, S. (2008). *Guide to Industrial Drying: Principles. Equipments & New Developments*.
- Odjo, D. P. S., Malumba Kamba, P., Beckers, Y., & Bera, F. (2015). Impact of drying and heat treatment on the feeding value of corn. A review. *Biotechnologie, Agronomie, Societe et Environnement= Biotechnology, Agronomy, Society and Environment [BASE]*, 19(3), 301-312.
- Paiva, F. F., Vanier, N. L., Berrios, J. D. J., Pinto, V. Z., Wood, D., Williams, T., & Elias, M. C. (2016). Polishing and parboiling effect on the nutritional and technological properties of pigmented rice. *Food chemistry*, 191, 105-112.
- Pillaiyar, P., & Mohandoss, R. (1981). Hardness and color in parboiled rices produced at low and high temperatures. *Journal of Food Science and Technology*, 18, 7-9.

- Pomeranz, Y., Stermer, R. A., & Dikeman, E. (1975). NMR-oil content as an index of degree of rice milling. *Cereal Chemistry*, 52, 849–853.
- Rahimi-Ajdadi, F., Asli-Ardeh, E. A., & Ahmadi-Ara, A. (2018). Effect of varying parboiling conditions on head rice yield for common paddy varieties in Iran. *Acta Technologica Agriculturae*, 21(1), 1-7.
- Ricestat, 2007. IRRI. [Http://www.irri.org/science/ricestat/index.asp](http://www.irri.org/science/ricestat/index.asp) (accessed Jan 2019).
- Saif, S. M., Suter, D. A., & Lan, Y. (2004). Effects of processing conditions and environmental exposure on the tensile properties of parboiled rice. *Biosystems engineering*, 89(3), 321-330.
- Saleh, N., Kim, H. J., Phenrat, T., Matyjaszewski, K., Tilton, R. D., & Lowry, G. V. (2008). Ionic strength and composition affect the mobility of surface-modified Fe₀ nanoparticles in water-saturated sand columns. *Environmental Science & Technology*, 42(9), 3349-3355.
- Sareepuang, K., Siriamornpun, S., Wiset, L., & Meeso, N. (2008). Effect of soaking temperature on physical, chemical and cooking properties of parboiled fragrant rice. *World Journal of Agricultural Sciences*, 4(4), 409-415.
- Smith, D. L., & Atungulu, G. G. (2018). Impact of drying deep beds of rice with microwave set at 915 mhz frequency on the rice milling yields. *Innovative Food Science & Emerging Technologies*, 45, 220-227.
- Smith, D. L., Atungulu, G. G., Sadaka, S., & Rogers, S. (2018). Implications of microwave drying using 915 mhz frequency on rice physiochemical properties. *Cereal Chemistry*, 95(2), 211-225.
- Soponronnarit, S., Nathakaranakule, A., Jirajindalert, A., & Taechapiroj, C. (2006). Parboiling brown rice using super heated steam fluidization technique. *Journal of Food Engineering*, 75(3), 423-432.
- Sun, Y., Wang, Y., Ni, X., Gao, Y., Shao, Q., Liu, L., & Liang, P. (2009). Comparison of ablation zone between 915-and 2,450-MHz cooled-shaft microwave antenna: results in in vivo porcine livers. *American Journal of Roentgenology*, 192(2), 511-514.
- Taghinezhad, E., Khoshtaghaza, M. H., Minaei, S., & Latifi, A. (2015). Effect of soaking temperature and steaming time on the quality of parboiled Iranian paddy rice. *International journal of food engineering*, 11(4), 547-556.
- Taghinezhad, E., Khoshtaghaza, M. H., Minaei, S., Suzuki, T., & Brenner, T. (2016). Relationship between degree of starch gelatinization and quality attributes of parboiled rice during steaming. *Rice Science*, 23(6), 339-344.

- USDA. (2014). Crop and stocks report. USDA-National Agricultural Statistics Service Arkansas. Retrieved from <http://www.nass.usda.gov/>
- Wimberly, J. E. (1983). Technical handbook for the paddy rice postharvest industry in developing countries. Los Baños, Laguna, Philippines: International Rice Research Institute, 1983, 5:103
- Xie, L., Mujumdar, A.S., Fang, X.M., Wang, J., Dai, J.W., Du, Z.L., Xiao, H.W., Liu, Y., Gao, Z.J. (2017). Far-infrared radiation heating assisted pulsed vacuum drying (FIR-PVD) of Wolfberry: effects on drying kinetics and quality attributes. *Food and Bioprocess Processing*, 2017, 102: 320-331
- Yousaf, K., Kunjie, C., Cairong, C., Abbas, A., Huang, Y., Arslan, C., & Xuejin, Z. (2017). The optimization and mathematical modeling of quality attributes of parboiled rice using a response surface method. *Journal of Food Quality*, 2017.

**CHAPTER 3: IMPACTS OF SPECIFIC POWER OF MICROWAVE AT 915 MHZ
FREQUENCY ON DRYING AND MILLING CHARACTERISTICS OF PARBOILED
ROUGH RICE**

ABSTRACT

The volumetric heating phenomenon provided by microwave (MW) may offer a means to quickly dry high moisture content (MC) parboiled rough rice in one-pass with minimal impacts on the kernel quality. The objectives of this research were to study the impacts of specific power of MW generated at 915 MHz frequency to dry high MC parboiled rough rice on moisture removal and milling characteristics of the rice. Long-grain rough rice of the cultivar (*cv.*) Mermentau at harvest MC of 31.6% dry basis (d.b.) was parboiled by soaking at 73 °C for 3 hours and then steamed at 67 kPa for 10 minutes. Following the parboiling process the sample was subjected to the MW drying. The drying was accomplished at MW specific powers that ranged from 0.37 to 8.77 kW. [kg-DM]⁻¹ (power per unit dry matter mass of the grain). These treatment levels of MW specific power were varied by heating parboiled rough rice for 2 and 6 minutes (mins) at MW powers that ranged from 1 to 24 kW. The process of parboiling increased the rough rice MC to 44.30% dry basis (d.b.). During the MW drying, as the specific power increased, the general tendency was for rough rice final moisture content (FMC), milled rice yield (MRY) and head rice yield (HRY) to decrease while the drying rate increased. Parboiled rough rice samples treated with a specific power of 8.77 kW.[kg-DM]⁻¹ while maintaining specific energy input at 0.29 kWh. [kg-DM]⁻¹ had least-square means FMC, drying rate, MRY and HRY of 19.73% d.b. (S.D ± 1.11%), 12.29% d.b. [min⁻¹] (S.D ± 0.79%), 68.18% (S.D ± 1.70%) and 67.51% (S.D ± 0.73%) respectively. However, treatment at a lower specific power of 2.92 kW.[kg-DM]⁻¹ while maintaining the same specific

energy input of 0.29 kWh. [kg-DM]⁻¹) resulted in least-square means FMC, drying rate, MRY and HRY of 21.21% d.b. (S.D ± 0.53%), 3.85% d.b. [min⁻¹] (S.D ± 0.13%), 73.22% (S.D ± 0.84%) and 73.21% (S.D ± 0.21%) respectively. The observed higher drying rate for treatments with higher specific power was associated with higher treatment powers and shorter treatment durations. Higher specific powers negatively impacted the observed MRY and HRY. The findings suggest that increased MW specific powers have a positive effect on rice MC reduction but above a certain threshold of specific power (2.92 kW.[kg-DM]⁻¹) may negatively affect the milling characteristics of the parboiled rice.

Keywords: One-pass drying; 915 MHz microwave; Specific power; Milling Yields; Parboiled rough rice

INTRODUCTION

To achieve optimal milling yield and quality, rough rice is harvested at moisture content (MC) of 23.5-26.6% dry basis (d.b), then dried to 13.6-14.9% d.b. before storage or further processing (henceforth MC is in dry basis). High-temperature, cross-flow column dryers and natural air in-bin dryers are the most common types of dryers used in the U.S. to dry rough rice (Maier & Bakker-Arkema, 2002). Of the two types of dryers, the cross-flow column dryers are the most popular type of rice dryer used at the industrial scale. In such dryers, grain flows vertically downward between two perforated metallic screens forming the grain columns. Heated air flows through the grain column in a direction perpendicular (or “cross”) to that of the grain movement (Billiris & Siebenmorgen, 2014). The duration that kernels reside inside the drying section of the columns is varied by controlling the unloading feed rolls, which are located at the bottom of the dryer. In

cross-flow dryers, rice kernels dry at different rates across the column thickness. Kernels closer to the heated-air plenum interact with hotter air and dry faster, while the kernels away from the plenum interact with cooler, more humid air and dry more slowly. This characteristic non-uniformity of cross-flow column dryers presents two challenges: under- and over-drying of the kernels and generation of fissures as a result of the MC and material state gradients in the kernels which impact the head rice yield (HRY).

To reduce the non-uniformity in drying, the grain is dried in more than one pass with tempering stages in between passes. Some commercial cross-flow column dryers are equipped with grain inverters (also called turnflows or grain exchangers), which switch the positions of kernels in the column (Prakash & Siebenmorgen, 2018). Tempering the rice (i.e. holding rice at elevated temperatures, typically the drying temperature, for 8 to 12 hours) after each drying pass allow intra-kernel MC and material state gradients, which are typically created during heated-air drying, to subside. Because these gradients are allowed to subside during tempering, fissuring and consequent HRY reductions are minimized (Atungulu & Sadaka, 2019). However, an increase in drying passes and the introduction of tempering stages lead to large drying energy inputs and longer drying duration. This puts a constraint on farmers since there already exists a short rice-harvesting “window” typically characterized with limited drying capacity at some farms.

For parboiled rough rice, rotary dryers are used to partially dry the rice before loading it into the cross-flow dryer. Rotary dryers require drying air temperatures of up to 100°C. During drying, the moisture removal takes place rapidly during the first stage of drying, when the rice is at MC range of 56 to 22% (d.b.). After the parboiled rice is partially dried in a rotary dryer, it is then transported to a cross-flow dryer to complete the drying process. Drying air temperatures of up to 75°C are used in cross-flow dryers; between drying periods, rice millers employ a tempering step

by stopping the drying process at about 22% M.C (d.b) to allow the rough rice MC to equilibrate for several hours before continuing the drying to 14%. There is need to improve the parboiled rough rice drying process to improve energy efficiency, reduce drying duration, and simplify the multi-stage process involved in the drying infrastructure. Introduction of a drying system that can dry high-MC parboiled rough rice lots to a MC level that is safe for long-term storage (13.6 – 14.9%), in one pass, with HRY comparable to or better than conventional drying methods could translate into considerable energy, time and cost savings for the rice milling industry.

MW heating at the 915 MHz frequency exemplifies a technology with great application possibilities in parboiled rough rice drying. The heating process with MWs is fundamentally different from conventional heating. During MW heating, heat is evenly distributed throughout the entire volume of the heated material. This contrasts with traditional thermal processing, which relies on conduction and convection from hot surfaces to deliver energy into the product. MW heating is very rapid as the material is heated by energy conversion rather than by energy transfer as with conventional techniques. MW heating is a function of the material being processed, and there is almost 100% conversion of electromagnetic energy into heat, mainly within the sample itself, unlike with convective heating where there are significant thermal energy losses. Due to the increased penetration depth of MWs at the 915 MHz frequency, the heating process delivers increased energy absorption, which increases the rate at which water from the agricultural product is removed. Atungulu et al. (2016) demonstrated the feasibility of using an industrial-type MW heating system to achieve one-pass drying of freshly-harvested medium-grain rough rice. The authors found that the volumetric heating and the high heat fluxes accorded by the MW were able to achieve single-pass rice drying of freshly harvested, high-MC rice (36.2%) to safe storage MC (14.9%) with improved HRYs.

At present, there is no research in the U.S. on the commercial use of MW technology for parboiled rough rice drying; however, based on past experimental results, it is expected that MW heating can sufficiently dry high-MC parboiled rough rice kernels in one pass. The high and rapid heat fluxes accorded by MW heating can quickly dry high-MC rice to storage MC with minimized quality reduction; however, it is unclear how the rice milling yields are affected by the MW's specific power. Rice milling yield is one parameter that determines the economic value of rice from the field to the mill and in the market (Lyman et al., 2013). Specific power is the rate at which MW specific energy is converted into internal thermal energy. As a result, this study specifically investigated the implications of increasing MW specific power on the final moisture content (FMC), drying rate, milled rice yield (MRY) and HRY of parboiled rough rice. By answering this question, insights can be given to rice processors, especially of parboiled rough rice, on the limits of processing durations for MW drying systems operated at the 915 MHz frequency. The rationale behind this study is that the successful implementation of the MW technology for parboiled rough rice drying would place the rice industry in a superior position to capitalize upon improved drying rates, HRY and possibly rice quality, thereby driving economic growth in the rice industry and in the U.S. agriculture sector as a whole. The development of the new technology aids in sustainability initiatives as it also minimizes food wastage and eliminates or reduces the use of fossil fuels that contribute to greenhouse gas emissions.

METHODS

Freshly-harvested, long-grain rice samples of cultivar (*cv.*) Mermentau at 31.58 % MC were used in this study. The samples were cleaned using dockage equipment (MCi Kicker Dockage Tester, Mid-Continent Industries Inc., Newton, KS). The equipment uses a series of small-sized

sieves to provide a fast, accurate, and consistent way of separating shrunken, broken, scalped material, broken kernels, splits, and dust from rice. The cleaned rice samples were stored in a laboratory cold room set at 4°C. At the beginning of the experiments, the samples were retrieved from the cold room and allowed to equilibrate with room temperature (25°C) overnight before conducting any experiments. The MCs of the samples that were reported in this study were determined using an AM 5200 Grain Moisture Tester (PERTEN Instruments, Hägersten, Sweden), which was calibrated according to Jindal and Siebenmorgen (1987). The FMC of each sample was validated using the oven method by placing 15 g duplicate samples into a conduction oven (Shellblue, Sheldon Mfg., Inc., Cornelius, OR) set at 130°C for 24 h, followed by cooling in a desiccator for at least half an hour (Jindal and Siebenmorgen, 1987).

Parboiling Procedure

A sample of 3600 g of rice was placed into a 45 cm by 45 cm piece of cheesecloth then allowed to soak in a lab-scale hot water bath set to soaking temperature of 73 °C for 3 hours. After soaking, the wet rough rice was steamed to complete the physicochemical changes of starch gelatinization. Rice in cheesecloth was steamed in a lab-scale autoclave set to a temperature of 113 °C and a pressure of 67 kPa for 10 minutes (mins).

The soaking temperature of 73 °C and steaming duration of 10 mins were decided based on a preliminary study. In this preliminary study it was determined that at these parboiling parameters, the long-grain rice of *cv. Mermentau* had optimum physicochemical and milling characteristics.

Microwave Equipment and Treatments

The MW (AMTek, Applied Microwaves Technology Inc., Cedar Rapids, IW) used in this research was designed for high power operations (up to 75 kW) and had a frequency of 915 MHz, which may allow heating of a deep rice bed. The system (Fig. 3.1) consists of a transmitter, a wave-guide, and the MW heating zone (oven). The transmitter is a high-powered vacuum tube that works as a self-excited MW oscillator. It is used to convert high-voltage electric energy to MW radiation. The wave-guide consists of a rectangular pipe through which the electromagnetic field propagates lengthwise. It is used to couple MW power from the magnetron into the lab oven. The lab oven is the internal cavity of the MW that provides uniform temperatures throughout while in use.

For each MW treatment, freshly parboiled rough rice samples were placed into MW safe trays for treatments. The outsides of the trays are made of polypropylene with a Teflon coated fiberglass mesh at the bottom to hold the samples. The trays' length, width and height were 40 cm, 30 cm and 5 cm, respectively. The bed thickness of the rice samples was 3.5 cm. The trays with rice samples were set in the oven on the belt and samples dried with MW (Table 3.1). The drying was accomplished at MW specific powers that ranged from 0.37 to 8.77 kW. [kg-DM]⁻¹ (power per unit dry matter mass of the grain). These treatment levels of MW specific power were varied by heating parboiled rough rice in batches for various durations (2 and 6 mins) at MW power that ranged from 1 to 24 kW. The specific power was obtained by dividing the MW specific energy by the drying duration. MW specific energy was defined as the energy applied per unit mass of the treated product's dry matter (kg-DM). For this research, the reference mass (*m*) was set as the initial mass of the grain dry matter. The MW specific energy was calculated as follows:

$$Q_s = \frac{p \times t_d}{m} \quad (1)$$

Where:

Q_s is specific energy per unit dry matter mass of treated product ($\text{kJ} \cdot \text{kg}^{-1}$ or $\text{kJ} \cdot [\text{kg-DM}]^{-1}$)

p is the microwave power supplied to the product (kW)

t_d is the drying duration of the treatment (s)

m is dry matter mass of the treated product (kg or $[\text{kg-DM}]^{-1}$)

After MW treatments, the samples were transferred immediately to glass jars and sealed airtight. The jars were placed in an environmental chamber (Platinous chamber, ESPEC North America, Inc. Hudsonville, MI) set at a temperature of 60°C . The rice was tempered for 4 h. After the tempering, the rice was spread uniformly on individual trays, transferred to an equilibrium moisture content (EMC) chamber (Platinous chamber, ESPEC North America, Inc. Hudsonville, MI) set at a temperature of 25°C and relative humidity (RH) of 65%.

For control sample treatment, rice samples (3 reps, 3600 g each) were soaked at 73°C for 3 hours, then steamed at 67 kPa for 10 mins. After that the samples were tempered for 4 hours at a temperature of 60°C . After tempering, the rice was placed in an EMC chamber (Platinous Chamber, ESPEC North America, Inc. Hudsonville, MI) set at 25°C , 65% RH, to allow for gentle drying to MC of 14.29%; the drying lasted 48 hours.

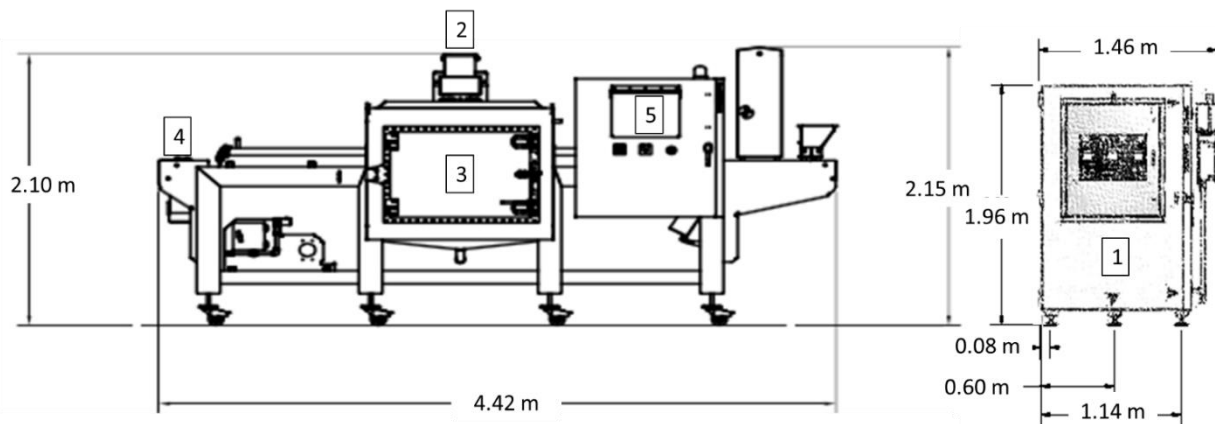

Figure 3.1: Schematic of the microwave system used in the study showing the transmitter (1), wave-guide (2), heating zone (3), conveyor belt (4), and control panel (5).

Table 3.1: Experimental design showing microwave power, microwave drying duration, parboiled rough rice mass, microwave specific energy, and calculated specific power.

Drying Duration (min)	Power (kW)	Mass (kg)	Specific Energy (kWh.[kg-DM] ⁻¹)	Specific power (kW.[kg-DM] ⁻¹)
2	3	3.6	0.04	1.10
2	6	3.6	0.07	2.19
2	9	3.6	0.11	3.29
2	12	3.6	0.15	4.39
2	15	3.6	0.18	5.48
2	18	3.6	0.22	6.58
2	21	3.6	0.26	7.68
2	24	3.6	0.29	8.77
6	1	3.6	0.04	0.37
6	2	3.6	0.07	0.73
6	3	3.6	0.11	1.10
6	4	3.6	0.15	1.46
6	5	3.6	0.18	1.83
6	6	3.6	0.22	2.19
6	7	3.6	0.26	2.56
6	8	3.6	0.29	2.92

The Drying rate (r_d) was expressed as the percentage point of MC removed per unit of drying duration (% d.b. [min⁻¹]) and computed using the following equation:

$$r_d = \frac{MC(t_{d0}) - MC(t_{d0} + \Delta t_d)}{\Delta t_d} \quad (2)$$

Where:

t_d is the drying duration (min)

$MC(t_{d_o})$ is the initial moisture content of the grain or at t_d of t_{d_o} or 0 min (% d.b.)

$MC(t_{d_o} + \Delta t_d)$ is the moisture content after drying duration of $t_{d_o} + \Delta t_d$ min (% d.b.)

Rice Milling

Triplicate, 150 g subsamples of rough rice, obtained from each treatment sample dried to 12.5% MC, were dehulled using a laboratory huller (Satake Rice Machine, Satake Engineering Co., Ltd., Tokyo, Japan), milled for 30 s using a laboratory mill (McGill #2 Rice Mill, RAPSCO, Brookshire, TX) and aspirated for 30 s using a seed blower (South Dakota Seed Blower, Seedboro, Chicago, IL). MRY was calculated as the mass proportion of rough rice that remains, including head rice and broken, after milling. Head rice was then separated from broken kernels using a double tray sizing machine (Grainman Machinery Manufacturing Corp., Miami, FL). Head rice is considered as kernels that remain at least three-fourths of the original kernel length after complete milling (USDA-GIPSA 2010). HRY was calculated as the mass proportion of rough rice that remains as head rice after complete milling.

Statistical Analysis

Statistical analyses using the Fit Model platform of JMP Pro (JMP Pro Version 15.1.0, SAS Institute). Standard least squares multiple regression models were using linear quadratic and two-way interactions among the predictors and to determine significant differences. The best predictors were selected using p-value (<0.05) to evaluate which independent variables (predictors) best-explained variations of continuous responses (dependent variables.)

RESULTS AND DISCUSSION

Impact of Specific Power on Drying Characteristics

The process of parboiling increased the rough rice MC to $44.30\% \pm 0.20\%$ dry basis (d.b.). It was clear that the input of the same specific energy into rice gave differences in results of FMC based on specific power input (Figure 3.2). For instance, considering samples treated with a specific energy of $0.29 \text{ kWh} \cdot [\text{kg-DM}]^{-1}$ and specific power of $8.77 \text{ kW} \cdot [\text{kg-DM}]^{-1}$, the rice samples had least-square means FMC of 19.73% (S.D $\pm 1.58\%$), whereas at the same specific energy but with a lower specific power of $2.92 \text{ kW} \cdot [\text{kg-DM}]^{-1}$ the samples had least-square means FMC of 21.22% (S.D $\pm 0.78\%$). The decreasing trend of FMC with decrease of specific power at constant specific energy was also observed in cases where the parboiled rough rice samples were exposed to low specific energies. For instance, considering samples treated with a specific energy of $0.04 \text{ kWh} \cdot [\text{kg-DM}]^{-1}$ and specific power of $1.10 \text{ kW} \cdot [\text{kg-DM}]^{-1}$, the least-square means of FMC was 35.75% (S.D $\pm 0.46\%$), whereas at the same specific energy but with specific power of $0.37 \text{ kW} \cdot [\text{kg-DM}]^{-1}$ the rice samples had least-square means FMC of 37.64% (S.D $\pm 2.17\%$). The observed higher changes of FMC for treatments with higher specific power was associated with higher treatment power during shorter treatment durations.

Al-Harashseh, Ala'a, & Magee (2009), whose research aimed at determining the effect of MW output power on the drying characteristics of tomato pomace, observed that substantially increasing MW output power increases the drying rate and thus decreasing drying duration. The mass transfer within the parboiled rough rice samples was higher when heated using higher MW powers as a result of the higher heat fluxes. These high heat fluxes create a substantial vapor pressure difference between the center and the surface of the product leading to higher drying rates. By contrast, at lower power levels, it will take a relatively longer duration before the temperature of the parboiled rough rice kernels reaches the level required for moisture transfer (evaporation) to take place.

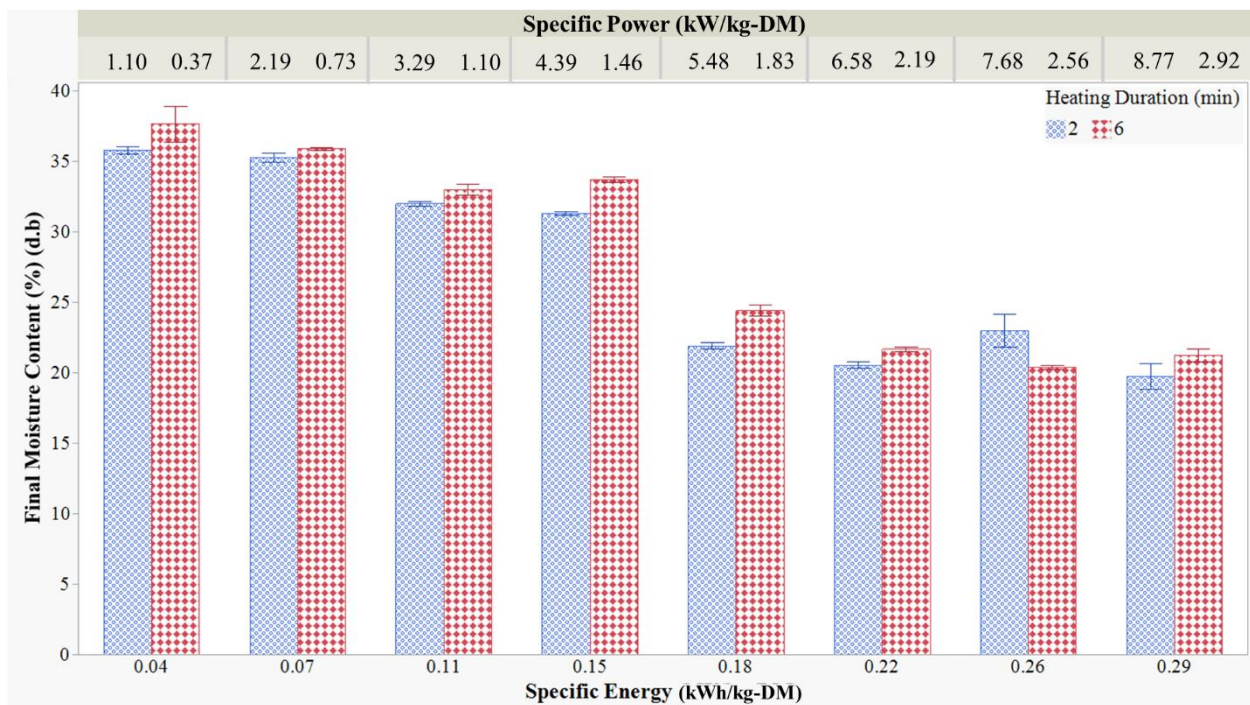

Figure 3.2: Effect of microwave specific power on the final moisture contents (FMC) of parboiled rough rice dried using a microwave at 915 MHz frequency; kg-DM indicates kg of dry matter (DM); initial moisture content of parboiled rough rice was 44.30% dry basis (d.b.).

The drying rate significantly changed as a result of increasing MW specific power (Figure 3.3). As the specific power increased, the general tendency was for drying rate to increase. It was clear that the input of the same specific energy into rice gave differences in results of drying rate based on whether specific power applied. For instance, considering samples treated with a specific energy of $0.29 \text{ kWh} \cdot [\text{kg-DM}]^{-1}$ and specific power of $8.77 \text{ kW} \cdot [\text{kg-DM}]^{-1}$, the rice samples had least-square means drying rate of $12.29\% \text{ d.b.} \cdot [\text{min}^{-1}]$ (S.D $\pm 0.77\%$), whereas at the same specific energy but with a lower specific power of $2.92 \text{ kW} \cdot [\text{kg-DM}]^{-1}$ the samples had least-square means drying rate of $3.85\% \text{ d.b.} \cdot [\text{min}^{-1}]$ (S.D $\pm 0.13\%$). The decreasing trend of drying rate with decrease of specific power at constant specific energy was also observed in cases where the parboiled rough rice samples were exposed to low specific energies. For instance, considering samples treated with a specific energy of $0.04 \text{ kWh} \cdot [\text{kg-DM}]^{-1}$ and specific power of $1.10 \text{ kW} \cdot [\text{kg-DM}]^{-1}$, the least-square means of drying rate was $4.28\% \text{ d.b.} \cdot [\text{min}^{-1}]$ (S.D $\pm 0.13\%$), whereas at the same specific energy but with specific power of $0.37 \text{ kW} \cdot [\text{kg-DM}]^{-1}$, the rice samples had least-square means drying rate was $0.56\% \text{ d.b.} \cdot [\text{min}^{-1}]$ (S.D $\pm 0.19\%$). The observed higher changes of drying rates for treatments with higher specific power was associated with higher treatment power during shorter treatment durations.

Figure 3.3 indicates that the drying rate was more rapid during higher MW specific power because more heat was generated within the sample creating a large vapor pressure difference between the center and the surface of the product due to volumetric heating characteristic of MW. Similar findings were reported in previous studies by Wang et al., (2007), Soysal et al., (2006), and Therdthai and Zhou, (2009) who conducted MW drying treatments on apple pomace, parsley and mint leaves, respectively.

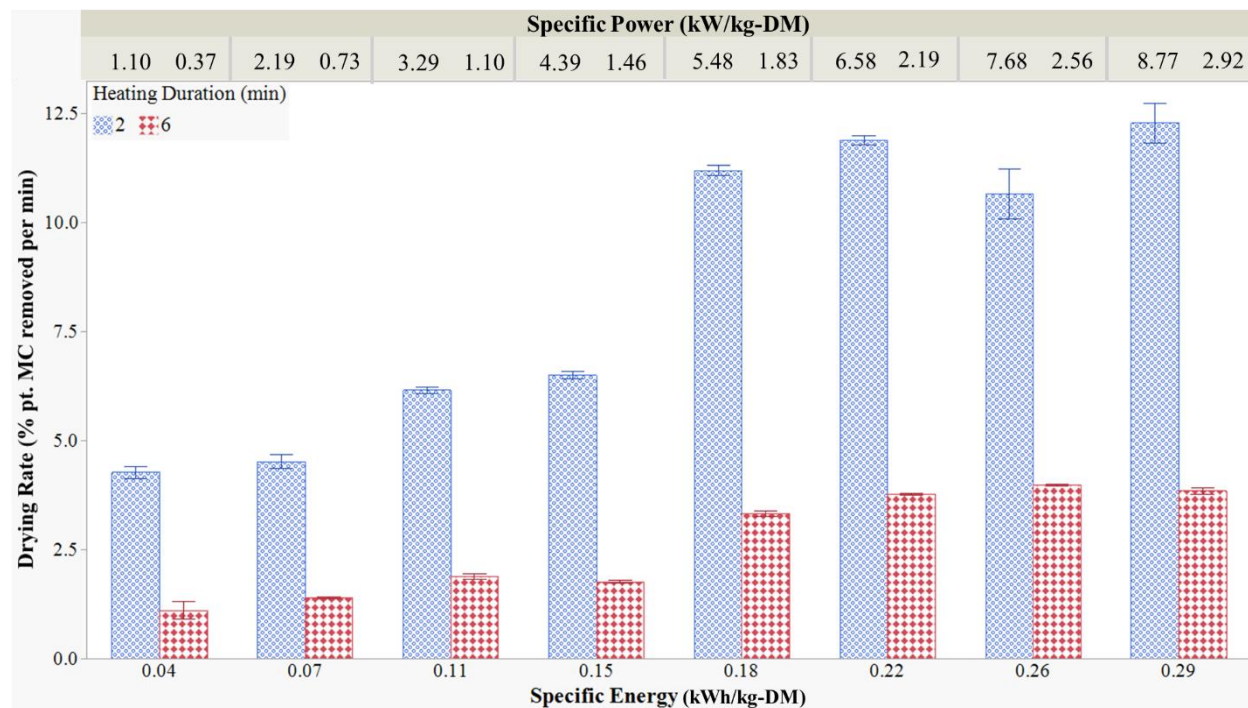

Figure 3.3: Effect of microwave specific power on the drying rate of parboiled rough rice dried using a microwave at 915 MHz frequency; % pt indicates percentage points; MC indicates moisture content in dry basis; kg-DM indicates kg of dry matter (DM).

Impacts of Specific Power on Milled Rice Yield and Head Rice Yield

The least-square means and standard deviations of the control samples that were parboiled and gently dried in the EMC chamber had MRY and HRY of $74.98\% \pm 0.17\%$ and $74.07\% \pm 0.57\%$, respectively. The implications of increasing the specific power for constant specific energy on the MRY were determined and are displayed in figure 3.4. As the specific power increased, the general tendency was for MRY to decrease. It was clear that the input of the same specific energy into rice gave differences in results of MRY based on specific power. For instance, considering samples treated with a specific energy of $0.29 \text{ kWh} \cdot [\text{kg-DM}]^{-1}$ and specific power of $8.77 \text{ kW} \cdot [\text{kg-DM}]^{-1}$, the rice samples had least-square means MRY of $68.18\% \text{ (S.D } \pm 1.70\%)$, whereas at the same specific energy but with a lower specific power of $2.92 \text{ kW} \cdot [\text{kg-DM}]^{-1}$ had least-square means MRY of $73.22\% \text{ (S.D } \pm 0.84\%)$. The increasing trend of MRY with decrease of specific

power at constant specific energy was also observed in cases where the parboiled rough rice samples were exposed to low specific energies. For instance, considering samples treated with a specific energy of $0.04 \text{ kWh} \cdot [\text{kg-DM}]^{-1}$ and specific power of $1.10 \text{ kW} \cdot [\text{kg-DM}]^{-1}$, the least-square means of MRY was 73.04% (S.D $\pm 0.10\%$), whereas at the same specific energy but with specific power of $0.37 \text{ kW} \cdot [\text{kg-DM}]^{-1}$ the rice samples had least-square means MRY of 73.78% (S.D $\pm 0.21\%$).

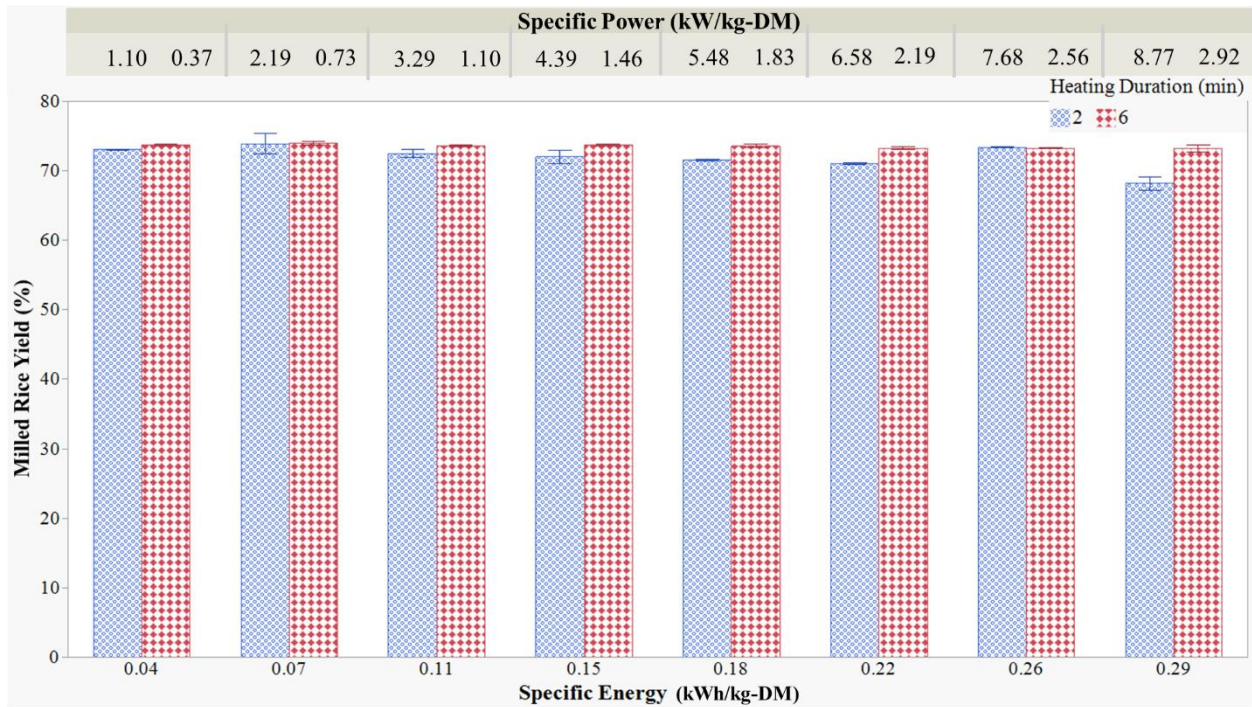

Figure 3.4: Effect of microwave specific power on the milled rice yields (MRY) of parboiled rough rice dried using a microwave at 915 MHz frequency; kg-DM indicates kg of dry matter (DM).

The implications of increasing the specific power for constant specific energy on the HRY were determined and are displayed in figure 3.5. As Figure 3.5 indicates, as the specific power increased, the general tendency was for HRY to decrease. For instance, considering samples treated with a specific energy of $0.29 \text{ kWh} \cdot [\text{kg-DM}]^{-1}$ and specific power of $8.77 \text{ kW} \cdot [\text{kg-DM}]^{-1}$,

the rice samples had least-square means HRY of 67.51% (S.D \pm 0.73%), whereas at the same specific energy but with a lower specific power of 2.92 kW.[kg-DM]⁻¹ the samples had least-square means HRY of 73.21% (S.D \pm 0.21%). The increasing trend of HRY with decrease of specific power at constant specific energy was also observed in cases where the parboiled rough rice samples were exposed to low specific energies. For instance, considering samples treated with a specific energy of 0.04 kWh.[kg-DM]⁻¹ and specific power of 1.10 kW.[kg-DM]⁻¹, the least-square means of HRY was 71.361% (S.D \pm 0.20%), whereas at the same specific energy input but with specific power of 0.37 kW.[kg-DM]⁻¹ the rice samples had least-square means HRY of 72.37% (S.D \pm 0.24%).

Heating of temperature-sensitive materials such as rice and other agricultural products can lead to gelatinization and cell damage, consequently leading to surface/case hardening. The case hardening in addition to causing differential stresses on the structure of the rough rice kernel thereby changing its tensile strength can also restrict moisture movement during the drying process leading to an accumulation of MC gradients. This subsequently leads to the formation of fissures. The presence of fissures on a rice kernel makes it more susceptible to breakage during subsequent hulling and milling processes and is correlated with decreases in milling yields (Smith & Atungulu, 2018; Smith et al., 2018; Fernando et al., 2008).

The decrease in MRY and HRY at high specific power can also be attributed to the increased surface temperatures and drying rates, which then contributed to increased MC and temperature gradients within the rice kernels. This increased MC and temperature gradients induce internal cracking of the kernel endosperm as a result of internal stresses and can lead to the development of fissures. According to Kunze & Hall (1967), MC gradients have a more significant effect than temperature gradients on stress creation within rice kernels. This was agreed upon by

Nagato et al. (1964), who researched crack development in rice kernels during drying. The authors' research indicated that crack formation is a consequence of the unequal shrinking of the endosperm, which results from uneven dehydration of the rice kernel. Schluterman and Siebenmorgen (2007) and Kobayashi et al. (1972) corroborated this theory by reporting that high-temperature drying of rice can create MC gradients within kernels, which can ultimately lead to fissure formation as a result of multiple stresses; this subsequently reduces the milling yields. Kunze & Choudhury (1972); Rhind (1962); Kunze (1979); Kobayashi, Miwa & Ishikowa (1972) have all reported that MC gradients create differential swelling or shrinking within the rice kernel, which induces kernel fissuring. Craufurd (1963) reported that the development of fissures in rice grains occurred after rapid drying. Additionally, the cracks formed in individual rice kernels developed as the MC gradient within the grain is relaxing. Since cracks originate at the center of the grain, they develop while the center of the grain is losing moisture to the drier outer layers.

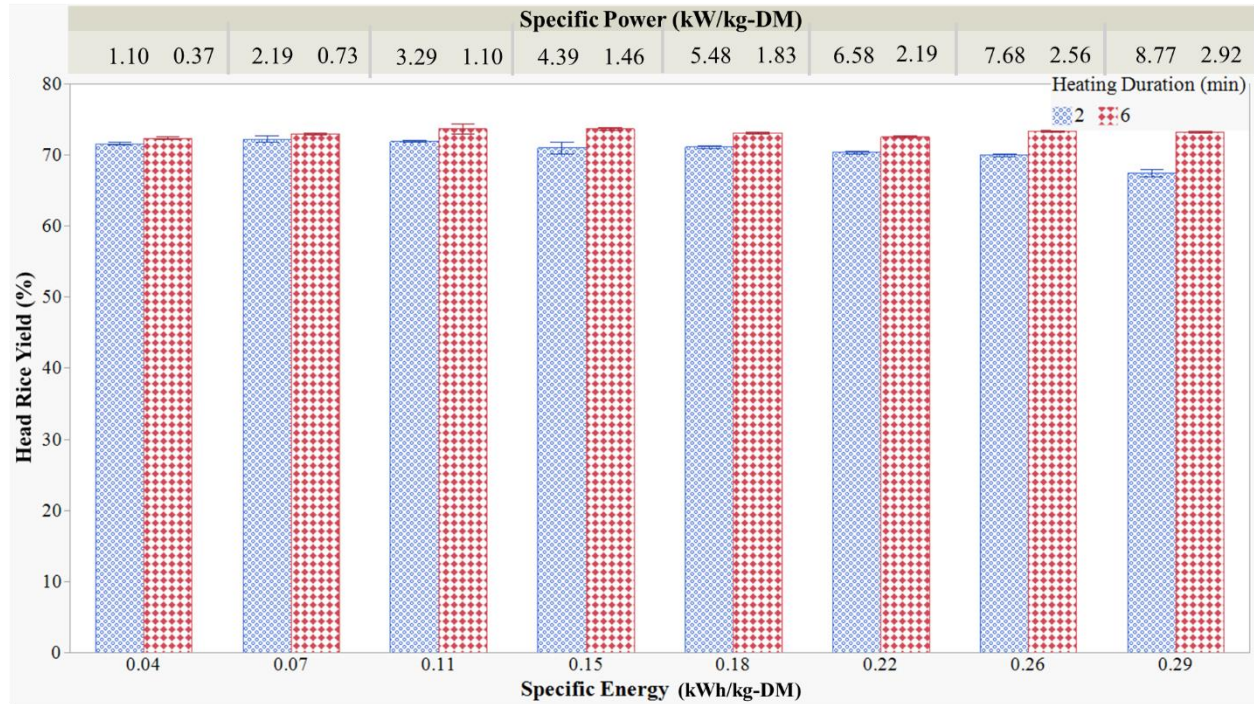

Figure 3.5: Effect of microwave specific power on the head rice yields (HRY) of parboiled rough rice dried using a microwave at 915 MHz frequency; kg-DM indicates kg of dry matter (DM).

In general, increasing the specific power had a negative effect on the MRY and HRY responses but had positive effect on the MC reduction. Increasing MW specific power had a statistically significant (<0.05) quadratic effect on the FMC, drying rate and HRY and a statistically significant (<0.05) linear effect on the MRY (Table 3.2).

Table 3.2: The effects of increasing microwave specific power on the final moisture content, drying rate, milled rice yield, and head rice yield of parboiled rough rice dried using a microwave at 915 MHz frequency.

Response	Source	P-Value
Final Moisture Content (%)	Specific Power	<0.0001
	Specific Power *Specific Power	0.01980
Drying Rate (percent points of moisture removed in dry basis)	Specific Power	<0.0001
	Specific Power *Specific Power	0.03974
Milled Rice Yield (%)	Specific Power	<0.0001
Head Rice Yield (%)	Specific Power	0.00004
	Specific Power *Specific Power	0.00196

CONCLUSION

This research investigated the feasibility of using a MW set at 915 MHz frequency to dry high-MC parboiled rough rice and evaluated impacts of specific power on post-drying milling characteristics. The process of parboiling long-grain rough rice of the cultivar (*cv.*) Mermentau at harvest MC of 31.6% by soaking at 73 °C for 3 hours and then steaming at 67 kPa for 10 minutes increased the rough rice MC to 44.30%. Results indicate that the high-MC parboiled rough rice treated at a low specific power of 2.92 kW.[kg-DM]⁻¹ produced parboiled rough rice with FMC of 21.22%, drying rate of 3.85% d.b. [min⁻¹], MRY of 73.22%, and HRY of 72.37%. However, rough rice subjected to the same parboiling conditions but treated at higher specific power of 8.77 kW.[kg-DM]⁻¹ produced parboiled rough rice with FMC of 19.73%, drying rate of 12.29% d.b. [min⁻¹], MRY of 68.18%, and HRY of 67.51%. The findings suggest that an increased MW specific power has a positive effect on rice MC reduction but negatively effects the rice milling characteristics. The least-square means and standard deviations of the control samples that were

soaked at 73°C, steamed for 10 min then gently dried in an EMC chamber set to 25 °C and 65% RH had MRY, and HRY of 74.98% and 74.07%, respectively. Compared to the MRY and HRY at the MW specific power of 2.92 kW.[kg-DM]⁻¹ (MRY of 73.22%, and HRY of 73.21%) there was negligible decrease in the yields due to the treatment. Therefore, based on this research, it is recommended that treatments of parboiled rough rice with MW specific power of 2.92 kW.[kg-DM]⁻¹ should not be exceeded to maintain MRY and HRY that are better or comparable to gently dried control samples. However, rice samples treated at this MW specific power but at lower MW specific energy was not able to sufficiently dry the parboiled rough rice from an initial MC of 44.30% to the safe MC for storage and milling MC of 14.3%. At the MW specific energy of 0.29 kWh.[kg-DM]⁻¹ and MW specific power of 2.92 kW.[kg-DM]⁻¹ rice was dried to 21.22%. Therefore, it is recommended that MW specific energies greater than 0.29 kWh. [kg-DM]⁻¹ are used without exceeding the MW specific power of 2.92 kW.[kg-DM]⁻¹. Alternatively, the rice can be dried to 21.22% using MW specific energy of 0.29 kWh. [kg-DM]⁻¹ and MW specific power of 2.92 kW.[kg-DM]⁻¹ then continue the rest of drying to 14.3% using natural or hot air.

This work showed that the use of MW energy at a frequency of 915 MHz for drying of rough rice holds promise as a rapid, one-pass drying method for parboiled rough rice. The technology could benefit the rice industry by reducing drying and/or overall processing durations, improve HRYs and implement an environmentally friendly drying method without greenhouse gas emissions.

ACKNOWLEDGMENTS

This study was based upon work that is supported, in part, by the United States Department of Agriculture National Institute of Food and Agriculture Hatch Act Funding and AMTEK Microwaves.

REFERENCES

- Atungulu, G. G., & Sadaka, S. (2019). Postharvest technology: Rice drying. In Rice (pp. 473-515). AACC International Press.
- Atungulu, G. G., Smith, D. L., Wilson, S. A., Zhong, H., Sadaka, S., and Rogers, S. (2016). Assessment of One-Pass Drying of Rough Rice with an Industrial Microwave System on Milling Quality. *Applied Engineering in Agriculture*, 32(3), 417-42.
- Billiris, M. A., & Siebenmorgen, T. J. (2014). Energy use and efficiency of rice-drying systems ii. Commercial, cross-flow dryer measurements. *Applied Engineering in Agriculture*, 30(2), 217-226.
- Craufurd, R.Q. (1963). Sorption and desorption in raw and parboiled paddy. *Journal of the Science of Food and Agriculture* 14(10):744-750.
- Fernando, W. J. N., Ahmad, A. L., Shukor, S. A., & Lok, Y. H. (2008). A model for constant temperature drying rates of case-hardened slices of papaya and garlic. *Journal of Food Engineering*, 88(2), 229-238.
- Jindal, V. K., and Siebenmorgen, T. J. (1987). Effects of oven drying temperature and drying time on rough rice moisture content determination. *Transactions of the ASAE*, 30(4), 1185-1192.
- Kobayashi, H., Miwa, Y., & Hayakawa, H. (1972). On the mechanism of the cracking in rice kernels during drying of paddies, particularly moisture distribution and drying strain in one kernel. *Research Bulletin* 33: 279–293. Gifu, Japan: Gifu University, Faculty of Agriculture
- Kobayashi, H., Miwa, Y., & Ishikowa, M. (1972). On the mechanism of cracking in rice kernels during drying of paddies particularly moisture distribution and drying strain in one kernel. *Research Bulletin of the Faculty of Agriculture of Gifu University*. 33: 279 - 293.
- Kunze, O. R. (1979). Fissuring of the rice grain after heated air drying. *Trans. ASAE* 22:1197-1202, 1207.
- Kunze, O. R., and Choudhary, M. S. U. (1972). Moisture adsorption related to the tensile strength of rice. *Cereal Chem* 49:684-696.
- Kunze, O. R., & Hall, C. W. (1967). Moisture adsorption characteristics of brown rice. *Transactions of the ASAE*, 10(4), 448-0450.
- Lyman, N. B., Jagadish, K. S., Nalley, L. L., Dixon, B. L., & Siebenmorgen, T. (2013). Neglecting rice milling yield and quality underestimates economic losses from high-temperature stress. *PloS one*, 8(8).

- Maier, D. E., & Bakker-Arkema, F. W. (2002). Grain drying systems. In Proceedings of the 2002 Facility Design Conference of the Grain Elevator & Processing Society, St. Charles, Illinois, USA, July (pp. 28-31).
- Nagato, K., Ebata, M., & Ishikawa, M. (1964). On the formation of cracks in rice kernels during wetting and drying of paddies. *Japanese Journal of Crop Science*, 33(1), 82-89.
- Prakash, B., & Siebenmorgen, T. J. (2018). Mathematical Modeling of a Cross-Flow Rice Dryer with Grain Inverters. *Transactions of the ASABE*, 61(5), 1757-1765.
- Rhind, D. (1962). The breakage of rice in milling. A review. *Tropical Agriculture (Trinidad)* 39:19-28.
- Schluterman, D. A., & Siebenmorgen, T. J. (2007). Relating rough rice moisture content reduction and tempering duration to head rice yield reduction. *Transactions of the ASABE*, 50(1), 137-142.
- Smith, D. L., & Atungulu, G. G. (2018). Impact of drying deep beds of rice with microwave set at 915 MHz frequency on the rice milling yields. *Innovative Food Science & Emerging Technologies*, 45, 220-227.
- Smith, D. L., Atungulu, G. G., Sadaka, S., & Rogers, S. (2018). Implications of microwave drying using 915 MHz frequency on rice physicochemical properties. *Cereal Chemistry*, 95(2), 211-225.
- Soysal, Y. (2004). Microwave drying characteristics of parsley. *Biosystems engineering*, 89(2), 167-173.
- Therdthai, N., & Zhou, W. (2009). Characterization of microwave vacuum drying and hot air drying of mint leaves (*Mentha cordifolia* Opiz ex Fresen). *Journal of Food Engineering*, 91(3), 482-489.
- Wang, Z., Sun, J., Chen, F., Liao, X., & Hu, X. (2007). Mathematical modelling on thin layer microwave drying of apple pomace with and without hot air pre-drying. *Journal of Food Engineering*, 80(2), 536-544.

CHAPTER 4: HEAT AND MASS TRANSFER CHARACTERISTICS IN PARBOILED RICE DURING HEATING WITH 915 MHZ MICROWAVE ENERGY

ABSTRACT

Microwave (MW) heating offers a fast method to dry high moisture content (MC) parboiled rough rice to safe storage MC in a single drying pass. However, there is limited research that describes the fundamentals of heat and mass transport in rice kernels exposed to MW energy at 915 MHz, which is the most promising heating frequency for industrialized processing. The objectives of this research were to investigate heat and moisture transport phenomena in high moisture long grain parboiled rice heated with MW energy at 915 MHz frequency. To simulate an industrial parboiling process, freshly-harvested rough rice was soaked for 3 hours (h) in a hot water bath with the temperature set at 73 °C and then steamed in a lab-scale autoclave for 10 minutes (mins). The high-MC parboiled long-grain rice (*cv.* XL753) was then heated using MW at powers of 2, 3, and 4 kW which corresponded with MW specific energies of 1.38, 2.07 and 2.76 kWh per kilogram of dry matter ($\text{kWh} \cdot [\text{kg-DM}]^{-1}$) after drying durations of 31.5 mins. Results show that after parboiling, the rice MC increased from an initial harvest MC of 32% dry basis (d.b.) to 56% (d.b.). Increasing the MW specific energy resulted in a considerable increase in MC reduction. The MW drying was characterized by two distinct drying-rate phases represented by first and second falling rate drying periods. Much of the rice drying occurred in the first falling-rate drying period. The drying constants (k) corresponding to treatments at 2, 3, and 4 kW were 0.05, 1.77, and 2.28 h^{-1} , respectively. The corresponding effective diffusivities (D_{eff}) at the same power levels were 8.40×10^{-10} , 1.40×10^{-9} and $1.79 \times 10^{-9} \text{ m}^2 \cdot \text{s}^{-1}$, respectively. The activation energy (E_a) of the drying process was determined to be $3.02 \text{ kW} \cdot \text{kg}^{-1}$. The information generated from this study is important

for understanding heat and mass transport in parboiled rough rice exposed to MWs at 915 MHz frequency. The data aid in the optimization of the MW drying process for parboiled rice drying.

Keywords: One-pass drying, 915 MHz microwave, parboiled rice, drying kinetics, activation energy, effective diffusivity

INTRODUCTION

Parboiled rice is rice that has been partially boiled in the husk. The three necessary steps of parboiling are soaking, steaming, and drying. The hydrothermal parboiling process causes the moisture content (MC) of rice to rise, sometimes above 56% dry basis (henceforth MC is in % dry basis). The high MC parboiled rice must be quickly dried to safe storage MC to avoid microbial proliferation and loss of milled rice yields, nutritional, functional, and sensory attributes.

Over 85% of industrial dryers are of the convective type using hot air (Mujumdar & Devahastin, 2008). The drying of parboiled rice is usually done in two stages. Rotary dryers are used to dry parboiled rough rice partially (to 22%) before loading it into cross-flow dryers. Rotary dryers require drying air temperatures of up to 100°C (Wimberly, 1983; Luh, 1991). After the parboiled rice is partially dried in a rotary dryer, it is then transported to a cross-flow dryer to complete the drying process. In this type of dryer, the airflow is generally perpendicular to the grain flow. Drying air temperatures of up to 75°C are used in cross-flow dryers (Wimberly, 1983; Luh, 1991). To minimize fissuring and potential breakage of rice kernels, rice is usually passed several times through the dryer removing limited percentage points of moisture in each pass (Ondier et al., 2012). Between drying periods, rice millers employ a tempering step by stopping the drying process. The process of tempering allows moisture and temperature gradients developed

inside rice kernels during drying to subside before continuing the drying to ~15% (Prakash, 2011). Drying in multiple passes to allow for tempering, however, is very energy-intensive and time-consuming. At peak harvest times, low rates of drying can create bottlenecks by limiting drying capacity (Berruto et al. 2011).

Microwave (MW) energy delivered at 915 MHz frequency is a very promising heating method for industrialized rice processing, especially for parboiled rice drying. The method of MW heating holds the potential to dry high-MC parboiled rice in one pass with the benefit of maintaining the grain quality. Atungulu et al. (2016) demonstrated the feasibility of using an industrial-type MW heating system to achieve one-pass drying of freshly harvested medium-grain rough rice. The authors found that supplying MW specific energies up to 0.30 kWh per kilogram of dry matter (unit henceforth expressed as kWh.[kg-DM]⁻¹), followed by 4 h of tempering at 60°C, was able to dry rice from 56% to final MCs in the range of 16% to 19%. The resulting head rice yield was not significantly different from that of rice gently dried with natural air at 25°C and relative humidity of 65%.

Olatunde et al., (2017) investigated the use of industrial MW at 915 MHz frequency for drying of rough rice with an emphasis on rice quality and energy use. The authors found that the specific energies of 0.22 kWh.[kg-DM]⁻¹ and 0.28 kWh.[kg-DM]⁻¹ were able to dry rough rice from 31.6% to 14.3% in one pass. Their energy analysis determined that at these MW specific energies, 1.27 kWh and 1.66 kWh were required per kg of water removed, respectively; this translated to \$13 and \$16 per metric ton of dried rice, respectively.

The ability to dry high-MC rice in one pass and the marginal reduction in head rice yield provided by MW drying could improve overall rice drying efficiency. The added merit of maintaining rice quality has the potential to boost financial returns to rice producers and

processors. This strongly justifies the need for research to optimize MW treatments to achieve commercially viable rice drying throughput, especially in rice parboiling operations, which typically require rapid drying of rice at very high initial MCs.

To successfully implement MW technology for parboiled rice drying, there is a need to explain the influence of MW on moisture removal characteristics, including drying rate, effective diffusivity of moisture (D_{eff}), and activation energy (E_a). The objective of this study was to investigate the heat and moisture transport phenomena in high moisture long-grain parboiled rice kernels heated by MW energy of the 915 MHz frequency. The investigated drying characteristics of the parboiled rice include moisture removal rate, the D_{eff} characteristics, and E_a of the process.

METHODS

Freshly-harvested, long-grain rice samples of cultivar XL753 at MC of 32 % were used in this study. The samples were cleaned using dockage equipment (MCi Kicker Dockage Tester, Mid-Continent Industries Inc., Newton, KS). The cleaned rice samples were stored in a laboratory cold room set at 4°C. At the beginning of the experiments, the samples were retrieved from the cold room and allowed to equilibrate with room temperature (25 °C) overnight before conducting any experiments. The MCs of the samples that were reported in this study were determined using an AM 5200 Grain Moisture Tester (PERTEN Instruments, Hägersten, Sweden), which is calibrated according to Jindal and Siebenmorgen (1987).

Differential Scanning Calorimetry

To determine the appropriate soaking temperature for rice parboiling, it was necessary to determine the onset gelatinization temperature of the rice cultivar used in the experiment. This was

done using differential scanning calorimetry. Rice at MC of 14.29% was milled then ground into flour using a cyclone mill with a 0.5 mm sieve (Model 2511, UDY Corp., Fort Collins, CO., USA). An 8 mg sample of rice flour was weighed into an aluminum pan, and 16 μ L of deionized water was added. The aluminum pan was hermetically sealed and equilibrated for 1 h before scanning from 25 to 120 °C at 10 °C per minute using a Differential Scanning Calorimeter (PyrisDiamon, Perkin-Elmer Co., Norwalk, CT, USA).

Parboiling Procedure

Rice samples (3 reps, 1000 g each) were placed into a 45 cm by 45 cm piece of cheesecloth then allowed to soak for 3 h in a lab-scale hot water bath set to soaking temperature of 76 °C (onset gelatinization temperature specific to the rice cultivar used). After soaking, the wet rough rice still in the cheesecloth was steamed for 10 mins in a lab-scale autoclave set to a pressure of 67 kPa and a corresponding temperature of 113 °C.

Control Samples

After rice samples are parboiled, instead of drying using the MW, samples were transferred immediately to glass jars and sealed airtight for tempering. The jars were placed in an incubator (VWR General Purpose Incubator 1536, Sheldon Manufacturing Inc., Cornelius, OR., USA) set at a temperature of 60 °C. The rice was tempered for 4 h. After the tempering, the rice was spread uniformly on individual trays, and then transferred to an equilibrium moisture content (EMC) chamber (Platinous chamber, ESPEC North America, Inc. Hudsonville, MI., USA) set at a temperature of 25 °C and relative humidity (RH) of 65%.

Microwave Equipment and Treatments

A schematic and description of the MW system used in this experiment (AMTek, Applied Microwaves Technology Inc., Cedar Rapids, IW.) are documented in our previous publication (Smith & Atungulu, 2018). For each MW treatment, freshly-parboiled rice samples were placed into MW safe trays for treatments. The outsides of the trays are made of polypropylene with a Teflon coated fiberglass mesh at the bottom to hold the samples.

MW treatments were conducted on batch samples exposed to power doses of 2, 3, and 4 kW with corresponding specific energies of 1.38, 2.07, and 2.76 kWh per kilogram of dry matter ($\text{kWh} \cdot [\text{kg-DM}]^{-1}$) for drying duration of 31.5 mins (Figure 4.1). The initial parboiled rice mass was held constant at 1000 g for all the experiments. The parboiled rice surface temperature during MW heating was measured using fiber optic temperature sensors (OMEGA Engineering, INC., Stamford, CT., USA).

After MW treatments, the rice samples were tempered and allowed to dry using the same equipment and methodology used for the control samples after parboiling.

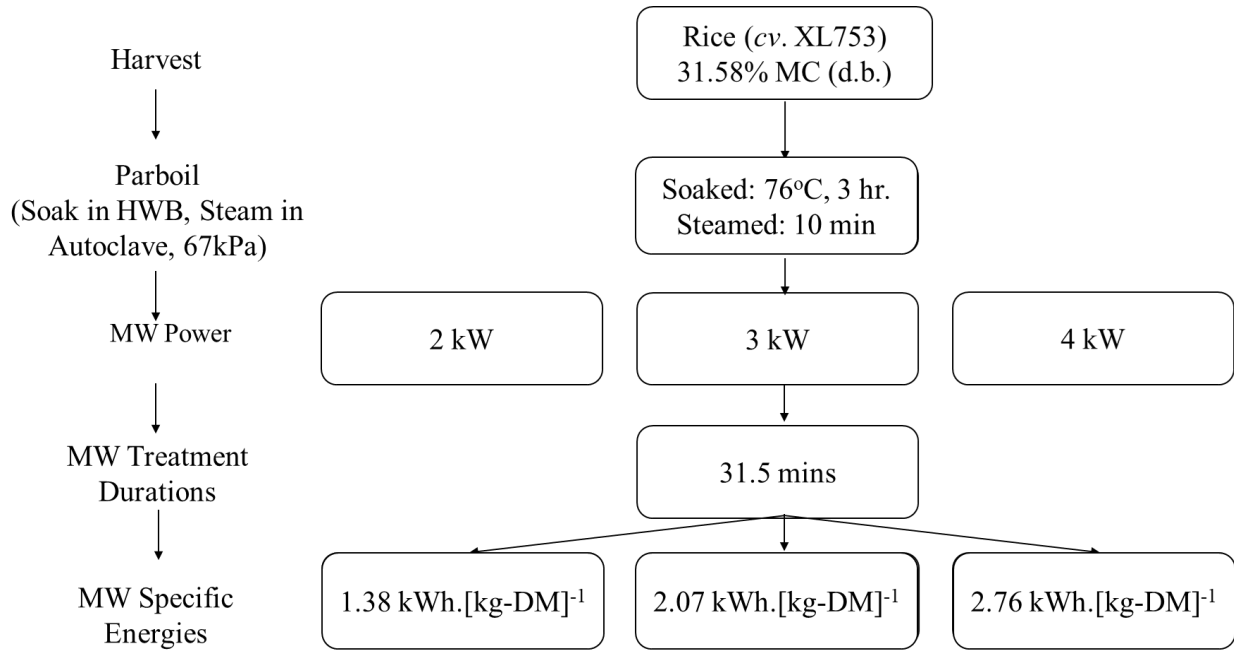

Figure 4.1: Overall experimental process flow diagram: *cv.*, HWB, MW, and MC indicates Cultivar, Hot Water Bath, Microwave, and Moisture Content, respectively; kg-DM indicates kg-DM indicates kg of dry matter; d.b. indicates dry basis.

Drying Characteristics and modeling

The drying rate (r_d) was expressed as the percentage point of MC removed per unit of drying duration (t_d) (% d.b. [min^{-1}]) and computed using the following equation:

$$r_d = \frac{Mct_{d_0} - Mct_{d_0 + \Delta t_d}}{\Delta t_d} \quad (1)$$

Where:

Mct_{d_0} is the initial MC at $t_d = 0$ min (% d.b.)

$Mct_{d_0 + \Delta t_d}$ is the MC after t_d mins ($t_{d_0} + \Delta t_d$) (% d.b.)

t_d is the drying duration (min)

The experimental drying data of MC during the drying process were used to calculate the dimensionless MR by using the following equation:

$$MR = \frac{MC - MC_e}{MC_0 - MC_e} \quad (2)$$

Where:

MC is the instantaneous MC (% d.b.)

MC_0 is the initial MC (% d.b.)

MC_e is the equilibrium MC (% d.b.)

For MW drying, it can be assumed that $MC_e = 0$ simplifying the equation (2) to:

$$MR = \frac{MC}{MC_0} \quad (3)$$

Parboiled rough rice surface temperature and MC measurements were taken at intervals on a new sample of parboiled rice for a drying duration that lasted 31.5 mins. The experimentally determined MR data were fitted to 4 semi-empirical drying models for describing the drying curve equation of parboiled rice (table 4.1).

Table 4.1: Semi-empirical drying models applied to drying curves of parboiled rice

Model Name	Model	Reference
Page	$MR = \exp(-kt^n)$	Alibas (2010)
Newton	$MR = \exp(-kt)$	Zanoelo et al. (2007)
Logarithmic	$MR = a \exp(-kt) + c$	Tarafdar et al. (2019)
Henderson and Pabis	$MR = a \exp(-kt)$	Fathi et al. (2016)

Note: k is the drying constant (h^{-1}), t is the drying duration (h), n is the reaction order, and a and c are dimensionless constants.

Microsoft Excel was used to calculate the constants k , a and c , of the 4 semi-empirical drying models using the solver tool. This was done by adjusting the model parameter values to minimize the sum of square errors (SSE) between the experimental MR s and the predicted MR s.

Determination of Effective Moisture Diffusivity

To determine the effective moisture diffusivity, D_{eff} , Fick's second law (Crank, 1979), shown in equation (4) was used:

$$\frac{\partial MR}{\partial t} = D_{eff} \left[\frac{\partial^2 MR}{\partial L^2} + \frac{2}{L} \frac{\partial MR}{\partial L} \right] \quad (4)$$

Where:

MR is the moisture ratio

D_{eff} is the effective moisture diffusivity ($\text{m}^2 \cdot \text{s}^{-1}$)

L is the half-thickness of the rice kernel (m)

Under the assumptions that both shrinkage and resistance to mass transfer at the surface of the kernel are negligible and that mass transfer is symmetric (Aregbesola et al., 2015; Khir et al., 2011; Das et al., 2003), equation (4) can be reduced to:

$$MR = \frac{6}{\pi^2} \exp\left(-\frac{\pi^2 \times D_{eff} \times t_d}{L^2}\right) \quad (5)$$

The linear form of Eq. (5) can be obtained by applying the natural logarithms as:

$$\ln(MR) = \ln\left(\frac{6}{\pi^2}\right) - \left(\frac{\pi^2 \times D_{eff}}{L^2}\right)t_d \quad (6)$$

Where π is the mathematical constant, 3.14. A plot of $\ln(MR)$ versus drying duration gives a straight line with a slope of:

$$\text{Slope} = -\left(\frac{\pi^2 \times D_{eff}}{L^2}\right) \quad (7)$$

The half-thickness of the rice kernel (L) was obtained by averaging the half thicknesses of 100 individual rice kernels. Measurements were taken using a caliper.

Calculation of Activation Energy in Microwave Drying

The E_a represents the minimum quantity of energy that the reacting species must possess to undergo a specified reaction. In a convective drying process, the E_a is calculated by using an Arrhenius type equation (Akpinar, & Toraman, 2016).

$$D_{eff} = D_o \exp^{-\frac{E_a}{RT}} \quad (8)$$

Where:

D_o is the pre-exponential factor of the Arrhenius equation ($m^2.s^{-1}$)

E_a is the activation energy ($kJ.mol^{-1}$)

R is the universal gas constant ($8.3143 kJ.mol^{-1}.K^{-1}$)

T is the absolute air temperature (K)

The E_a is determined from the slope of the Arrhenius plot, $\ln(D_{eff})$ versus the inverse of the air temperature (T^{-1}). Because the air temperature is not precisely measurable inside the MW oven, a modified form of the Arrhenius equation derived by Özbek and Dadali (2007) was used to illustrate the relationship between the D_{eff} and the ratio of the MW output power to sample mass (m/p) instead of the air temperature for the calculation of E_a .

$$D_{eff} = D_o \exp^{-\frac{E_a m}{p}} \quad (9)$$

Where:

p is the MW output power (kW)

m is the initial wet mass of product being treated (kg)

E_a is the activation energy ($kW.kg^{-1}$)

The linear form of Eq. (10) can be obtained by applying the natural logarithms as:

$$\ln(D_{eff}) = \ln(D_o) - \frac{E_a m}{p} \quad (10)$$

A plot of $\ln(D_{eff})$ versus m/p can be used to determine the E_a associated with a process condition.

Statistical Analysis

Statistical analyses using the Fit Model platform of JMP Pro (JMP Pro Version 15.1.0, SAS Institute). Standard least squares multiple regression models were using linear quadratic and two-way interactions among the predictors and to determine significant differences. The best predictors were selected using p -value (<0.05) to evaluate which independent variables (predictors) best-explained variations of continuous responses (dependent variables.)

The reduced χ^2 , RMSE, R^2 , and adjusted R^2 values were used to evaluate the fit quality of selected models. Microsoft Excel was used to calculate the R^2 , and adjusted R^2 values using the Data Analysis tool. The higher the R^2 and Adjusted R^2 values and the lower the reduced χ^2 and RMSE values, the better is the goodness of fit (Ertekin and Yaldiz, 2004; Doymaz and Ismail, 2011).

The reduced χ^2 , and $RMSE$ values can be calculated as follows:

$$\chi^2 = \frac{\sum_{i=1}^N (MR_{exp,i} - MR_{pre,i})^2}{N-z} \quad (11)$$

$$RMSE = \sqrt{\left[\frac{1}{N} \sum_{i=1}^N (MR_{exp,i} - MR_{pre,i})^2 \right]} \quad (12)$$

Where:

$MR_{exp,i}$ is the i th experimental MR

$MR_{pre, i}$ is the i th predicted MR

N is the number of experimental data points

z is the number of parameters in the model

RESULTS AND DISCUSSION

Gelatinization Properties

The onset, peak, and end gelatinization temperatures were determined to be 76.4, 81.7, and 89.0 °C (Fig. 4.2). The enthalpy was determined to be 10.1 J.g⁻¹. Leethanapanich (2015) indicates that there is a more pronounced decrease in chalkiness and an increase in head rice yield for parboiled rice when the soaking temperature was closer to the onset gelatinization temperature. As a result, the soaking temperature used for parboiling in our experiment was 76 °C.

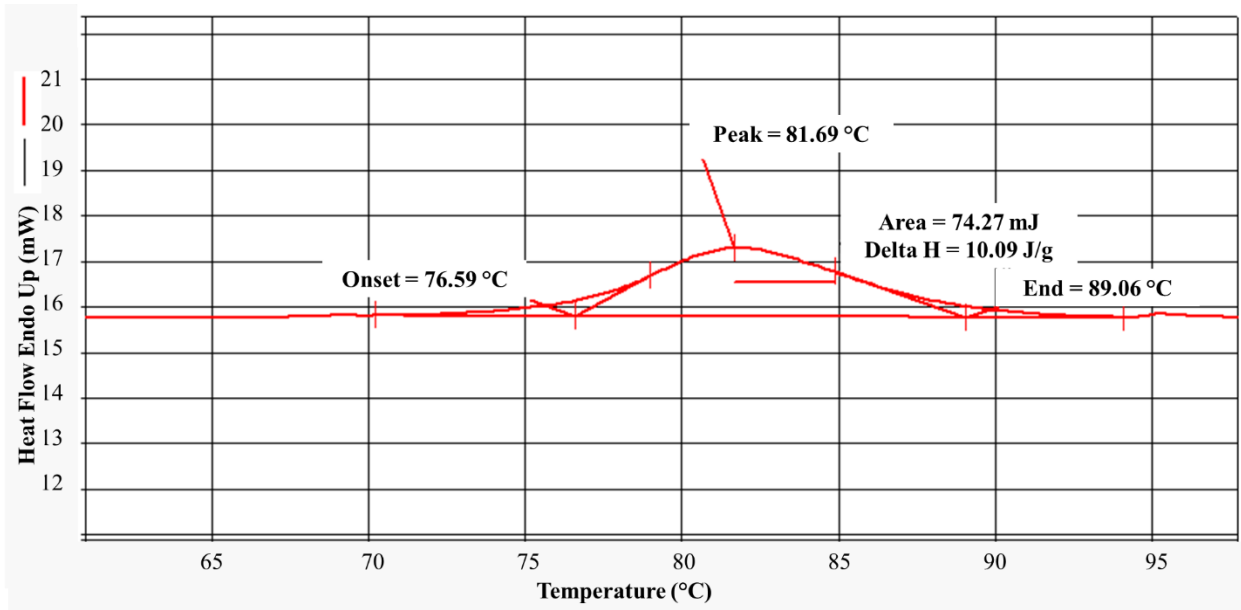

Figure 4.2: A schematic differential scanning calorimetry curve generated for long-grain rice of cultivar XL-753

Parboiled Rice Moisture Removal Characteristics

The MC of rough rice immediately after parboiling was determined to be 55.96 %. The *FMC* changes during the MW drying at MW power levels of 2, 3 and 4 kW were determined. For MW power levels of 2 and 3 kW, there was a statistically significant linear decrease in MC with respect to drying duration. Using 2 and 3 kW of MW treatment allowed drying durations of up to 31.5 min. However, treatments at 4 kW caused rice to burn within shorter drying durations which was less than 21.5 min. Table 4.2 shows the summary of fit table of the effect of drying duration on the *FMC* of parboiled rice dried with the 915 MHz microwave.

Table 4.2: Summary of fit table showing the effect of drying duration (t_d) on the final moisture content of parboiled rice dried with a 915 MHz microwave; *FMC* is the final moisture content (% d.b.); Q_s is the microwave specific energy (kWh.[kg-DM]⁻¹)

	Power Level = 2 kW [$Q_s = 1.38$; $t_d=31.5$]	Power Level = 3 kW [$Q_s = 2.07$; $t_d=31.5$]	Power Level = 4 kW [$Q_s = 1.89$; $t_d=21.5$]
Prediction Expression	$FMC = 38.02 - 0.76(t_d)$	$FMC = 37.69 - 1.02(t_d)$	$FMC = 38.30 - 1.85(t_d) + 0.02(t_d)^2$
R-Square	0.974964	0.978996	0.998205
Adjusted R-Square	0.973647	0.977683	0.997488
Root Mean Square Error	1.165311	1.3023	0.53855
P-Value	<0.0001	<0.0001	<0.0001

Applying 2 kW of MW power over a 31.5 min drying duration to a 1 kg mass of parboiled rice (MW specific energy of 1.38 kWh.[kg-DM]⁻¹) resulted in a parboiled rice *FMC* of 15.58% with a standard deviation of 1.40% (SD = 1.40%), which is within the desired *FMC* range for safe storage (14.29 to 15.61%). Applying 3 kW of MW power over a 31.5 min drying duration to a 1

kg mass of parboiled rice (MW specific energy of $2.07 \text{ kWh} \cdot [\text{kg-DM}]^{-1}$) resulted in a parboiled rice *FMC* of 7.26% (SD = 0.23%) at drying duration of 31.5 min which overdried the rice outside of the desired *FMC* range for marketing and safe storage (14.29 to 15.61%); at this power level and drying duration of 31.5 min, there was visible popping of the individual rice kernels and the smell of burned grain. Applying 4 kW of MW power over a 21.5 min drying duration to 1 kg mass of parboiled rice (MW specific energy of $1.89 \text{ kWh} \cdot [\text{kg-DM}]^{-1}$) resulted in popping of the individual rice kernels and the smell of burning grain was noted after drying duration of 11.5 mins. The *FMCs* after treatment of parboiled rough rice for various durations and MW powers is shown in figure 4.3.

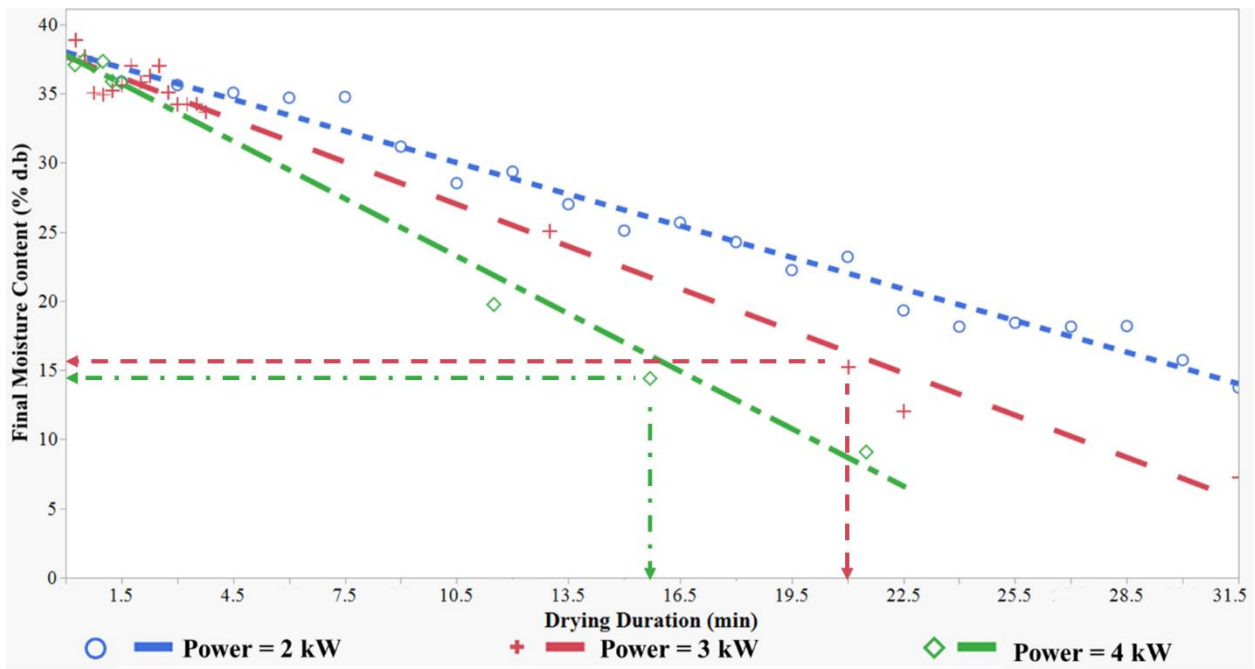

Figure 4.3: Parboiled rice moisture removal kinetics during microwave drying with a 915 MHz microwave as a function of drying duration (initial product mass was 1 kg and the initial moisture content of the parboiled rice was 55.96%).

Drying Rate

The drying rate significantly changed as a result of increasing drying duration for MW power levels of 2 and 3 kW. Unlike treatments with MW power of 2 and 3 kW, the drying rate response for treatment with MW power of 4 kW was not statistically significant (table 4.3). The treatment at MW powers of 2 and 3 kW resulted in statistically significant quadratic responses as drying duration increased.

For the MW power of 2 kW, it was noted that the drying rate was highest from 1.5 mins to 7.5 mins. For example, at the MW power at 2 kW, after 1.5 mins of drying, the least square mean of the drying rate was 13.39 percentage point MC removed per minute (% d.b. [min^{-1}]) (S.D=1.67). This drying rate decreased quadratically to 2.83 (% d.b. [min^{-1}]) (S.D = 0.03) at the 7.5 min drying duration. From the 7.5 min, the drying rate steadily decreased to the lowest drying rate of 1.34 (% d.b. [min^{-1}]) (S.D = 0.04) at 31.5 min drying duration.

For the MW power of 3 kW, the drying rate was also highest from 1.5 mins to 7.5 mins. For example, at the MW power of 3 kW, after 1.5 mins of drying, the least square mean of the drying rate was 26.46 (% d.b. [min^{-1}]) (S.D=0.04). This drying rate decreased quadratically to 9.15 (% d.b. [min^{-1}]) (drying rate obtained from prediction expression) at the 7.5 min drying duration. From the 7.5 min, the drying rate steadily decreased to the lowest drying rate of 2.16 (% d.b. [min^{-1}]) (S.D = 0.01) at 31.5 min drying duration.

Table 4.3: Summary of fit table showing the effect of drying duration t_d (min) on drying rate of parboiled rice dried with a microwave at 915 MHz; r_d is the drying rate (min); Q_s is the microwave specific energy (kWh.[kg-DM]⁻¹)

	Power Level = 2 kW [$Q_s = 1.38$ at $t_d=31.5$]	Power Level = 3 kW [$Q_s = 2.07$ at $t_d=31.5$]	Power Level = 4 kW [$Q_s = 1.89$ at $t_d=21.5$]
Prediction Expression	$r_d = 10.08 - 0.86 (t_d) + 0.02 (t_d)^2$	$r_d = 21.79 - 2.06 (t_d) + 0.05 (t_d)^2$	NA
R-Square	0.724765	0.789396	0.806141
Adjusted R-Square	0.694183	0.747275	0.612282
Root Mean Square Error	1.519667	3.67461	8.061078
P-Value	<0.0001	0.0004	0.2903

Figure 4.4 indicates that the drying rate can be divided into two very distinct periods, the first rapid falling rate period (drying duration of 1.5 to 7.5 min), and the second slower falling rate period (drying duration of 7.5 to 31.5 min). The first rapid falling rate period corresponded with the duration when the parboiled rice mass contained a large amount of water, including free moisture at the surface. As a result, the parboiled rice mass drying behavior can be compared to the drying behavior of an open-faced body of water. After a short period of time the surface of the solid is no longer saturated, and the drying rate decreases with the decrease in MC. At the beginning of the second falling rate period (drying duration of 7.5 min), the surface moisture film has evaporated fully, and with the further decrease in MC, the drying rate is controlled by the rate of moisture movement through the solid. The second falling rate period (drying duration of 7.5 to 31.5 min) took a far longer time than the falling rate period, even though moisture removal during the first falling rate period was much less than the second falling rate period. This trend was also seen in experiments by Standish, et al. (1988) in their research to dry brown coal agglomerates

using a MW at 2450 MHz frequency and power levels of up to 650 W. After the rapid initial moisture movement during the first falling rate period, the drying rate steadily slowed down. As the moisture from the sample is removed, the absorbed power decreases, and the drying characteristics approached that of convective drying (Perkin, 1980). Metaxas and Meredith (1988) also experienced this effect, which they called "moisture leveling." The authors explained that MWs selectively heat moist regions where MW absorption is higher. Since the loss factor is mostly related to MC, the wet parts of the material will absorb more MW energy leading to higher evaporation rates at the beginning of drying. Still, this rate tends to level off as drying continues as the less moist parts of the material will not absorb much of the MW energy.

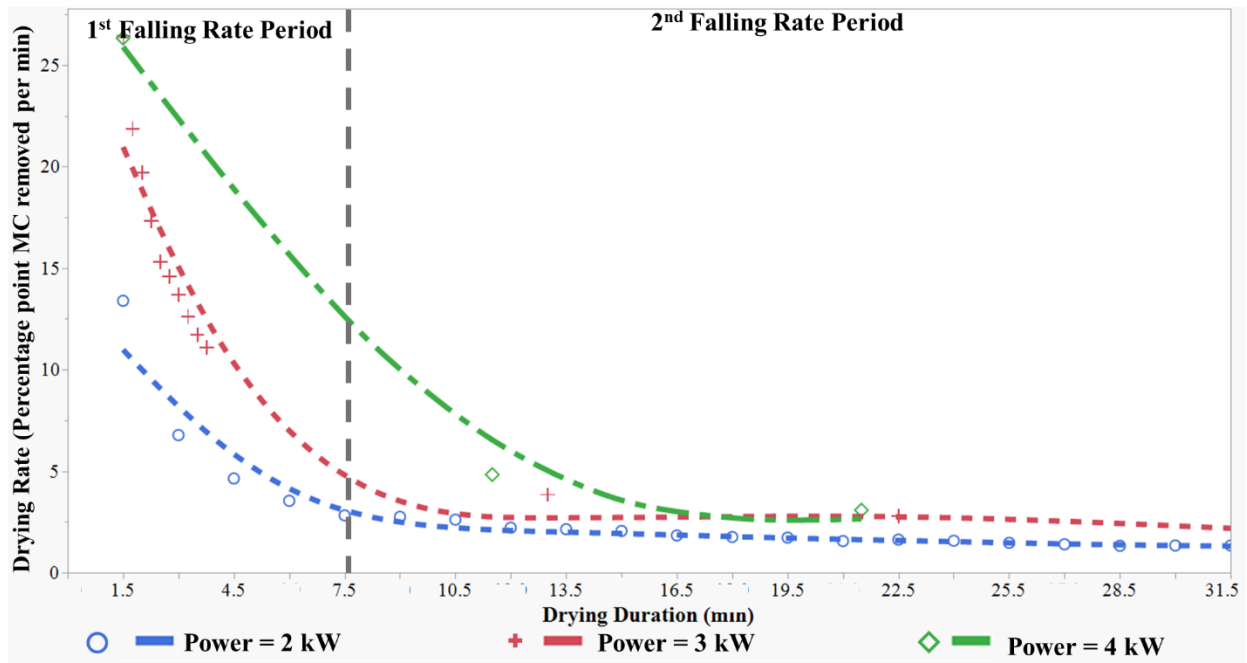

Figure 4.4: Parboiled rice drying rate kinetics during microwave drying with a 915 MHz microwave as a function of heating duration (initial product mass was 1 kg and the initial moisture content of the parboiled rice was 55.96% dry basis)

Drying Models

It was determined that at MW power level of 2 kW with drying duration of 31.5 min (MW specific energy of 1.38 kWh.[kg-DM]⁻¹), it was feasible to dry the parboiled rice, in one pass, from the initial MC of 55.96 % to a *FMC* of 15.58 %, which is within the desired *FMC* range for safe storage (14.29 to 15.61%). The MW power levels of 3 and 4 kW with drying duration of 31.5 mins and 21.5 mins respectively (MW specific energy of 2.07 and 1.89 kWh.[kg-DM]⁻¹ respectively) dried the parboiled rice to *FMCs* outside of the desired *FMC* range for safe storage and marketability of the rice. Additionally, due to the high specific powers calculated of 3.95 and 5.26 kW.[kg-DM]⁻¹ at MW power levels of 3 and 4 kW with drying duration of 31.5 mins and 21.5 mins respectively (MW specific energy of 2.07 and 1.89 kWh.[kg-DM]⁻¹ respectively) the rice milling yields and quality characteristics are expected to be negatively affected. Furthermore, even at a MW power of 3 kW and a reduced drying duration of 21 mins or a MW power of 4 kW at a reduced drying duration of 15.75 mins (MW specific energy of 1.38 kWh.[kg-DM]⁻¹) which would give *FMCs* of 15.46 and 14.84% respectively (*MCs* in the desirable range of 14.29 to 15.61% for safe storage) this would still result in specific powers greater than 2.92 kW.[kg-DM]⁻¹. Specific powers greater than 2.92 kW.[kg-DM]⁻¹ was determined to be unsafe for preserving rice milling yields and quality characteristics in preliminary experiments. The rice milling yields determine the economic value of rice (Lyman et al., 2013).

Drying at MW power levels of 2, 3 and 4 kW with drying durations of 31.5, 31.5 and 21.5 mins yielded drying constants (*k*) of 0.05, 1.77 and 2.28 h⁻¹, respectively. If MW drying were conducted at MW power levels of 3 and 4 kW with reduced drying durations of 21 and 15.75 mins (MW specific energy of 1.38 kWh.[kg-DM]⁻¹), the values of *k* would be 0.13 and 2.29 h⁻¹. These results indicate a trend of increasing *k* values as power level increases even at the same MW

specific energy of $1.38 \text{ kWh} \cdot [\text{kg-DM}]^{-1}$. To mitigate impacts of high heat flux on rice quality, using a lower power level seems reasonable. The rough rice surface temperature immediately after parboiling was determined to be $54.73 \text{ }^\circ\text{C}$. It was determined that as the drying duration increased, so did the parboiled rice surface temperature increase. After Heating the parboiled rice at MW power level of 2 kW for drying duration of 31.5 min the parboiled rice surface temperature increased to $92.61 \text{ }^\circ\text{C}$.

The logarithmic model gave the best prediction of *MR* data during this treatment. The constants for each semi-empirical drying model are given in table 4.4. For the 4 semi-empirical drying models used, the *k* ranged from 0.311 to 2.805 h^{-1} . Table 4.4 also shows the R-Square, Adjusted R-Square, χ^2 , and Root Mean square Error values of the 4 semi-empirical drying models. Our results showed that the logarithmic model had the best agreement with the experimental data for the parboiled rice drying. The logarithmic model was chosen based on its R^2 and Adjusted R^2 values being closest to 1 and having the lowest χ^2 and *RMSE* values.

Table 4.4: Semi-empirical drying models and constants for predicting the moisture ratio as affected by drying duration for drying parboiled rough rice with a 915 MHz microwave at a power of 2 kW for a drying duration of 31.5 mins (unit mass of parboiled rice at initial moisture content of 55.96%, MW specific energy of 1.38 kWh.[kg-DM]⁻¹); R-square, adjusted R-square, reduced chi-square, and root mean square error values.

Model Name	Constants	R-Square	Adjusted R-Square	Reduced Chi-Square	Root Mean Square Error
Page	$k = 0.31 \text{ h}^{-1}$ $n = 9.01$	98.29×10^{-2}	98.10×10^{-2}	39.23×10^{-2}	2.14×10^{-2}
Newton	$k = 2.81 \text{ h}^{-1}$	98.29×10^{-2}	98.10×10^{-2}	39.23×10^{-2}	2.14×10^{-2}
Logarithmic	$a = 15.85$ $k = 0.05 \text{ h}^{-1}$ $c = -15.18$	99.99×10^{-2}	99.99×10^{-2}	1.88×10^{-2}	0.06×10^{-2}
Henderson & Pabis	$a = 0.73$ $k = 1.87 \text{ h}^{-1}$	98.85×10^{-2}	98.73×10^{-2}	2.37×10^{-2}	1.75×10^{-2}

Effective Moisture Diffusivity

The D_{eff} was calculated and is displayed in table 4.5. From this table, it can be extrapolated that when the original product mass and drying duration are held constant as power increases, the D_{eff} also increases. For example, at the MW power level of 2 kW the D_{eff} was $8.40 \times 10^{-10} \text{ m}^2.\text{s}^{-1}$, at the MW power level of 3 kW the D_{eff} was $1.40 \times 10^{-9} \text{ m}^2.\text{s}^{-1}$, and at the MW power level of 4 kW the D_{eff} was $1.79 \times 10^{-9} \text{ m}^2.\text{s}^{-1}$. This trend was also seen by Demiray et al. (2017) and Panda et al. (2017).

In the experiment by Demiray et al. (2017) to dry onion slices at 2450 MHz MW frequency, the authors calculated a D_{eff} of $8.47 \times 10^{-6} \text{ m}^2.\text{s}^{-1}$ for 0.557 kW power level of treatment, followed by $7.13 \times 10^{-6} \text{ m}^2.\text{s}^{-1}$ at 0.447 kW with the MW power of 0.328 kW having the lowest D_{eff} of $4.32 \times 10^{-6} \text{ m}^2.\text{s}^{-1}$. In the study by Panda et al. (2017), it was determined that at the 0.18 kW power level, the calculated D_{eff} was $8.33 \times 10^{-9} \text{ m}^2.\text{s}^{-1}$, at the 0.36 kW power level, the calculated D_{eff} was

$2.22 \times 10^{-8} \text{ m}^2 \cdot \text{s}^{-1}$, at the 0.54 kW power level, the calculated D_{eff} was $3.33 \times 10^{-8} \text{ m}^2 \cdot \text{s}^{-1}$, and at the 0.72 kW power level, the calculated D_{eff} was $5.00 \times 10^{-8} \text{ m}^2 \cdot \text{s}^{-1}$. These D_{eff} values were calculated for rice of IR36 (semi-dwarf) cultivar at 1.5 cm bed thickness treated using a 2450 MHz MW. The increased heating energy can explain the trend of increasing D_{eff} values that were correlated with increasing MW power output at higher MW power, which would increase the activity of the water molecules leading to higher D_{eff} . The D_{eff} for the MW power levels of 2, 3, and 4 kW lie in the range of D_{eff} for food materials of $1.67 \times 10^{-9} \text{ m}^2 \cdot \text{s}^{-1}$ to $1.67 \times 10^{-7} \text{ m}^2 \cdot \text{s}^{-1}$ (Babalís and Belessiotis, 2004; Kaushal & Sharma, 2013).

It could be noted that the D_{eff} values for the rice of IR36 (semi-dwarf) cultivar treated using a 2450 MHz MW (Panda et al. 2017) and the onion slices dried at 2450 MHz MW frequency (Demiray et al., 2017) were higher than the D_{eff} values calculated for this experiment. This could be due to those products' higher porosity compared to that of parboiled long grain rice kernels. Additionally, it is possible that case hardening of the parboiled rice kernels occurred at the elevated temperatures caused by the MW drying at high power levels (Fernando et al., 2008). As a result, moisture diffusion through the parboiled rice kernels was restricted during the drying process.

Activation Energy

Using the ratios of m/p and D_{eff} values for MW treatments at power levels of 2, 3, and 4 kW the E_a was calculated. The E_a was calculated to be $3.02 \text{ kW} \cdot \text{kg}^{-1}$ (table 4.5). The E_a of Panda et al. (2017), which was a MW drying process of rough rice at 2450 MHz frequency was also very close to that calculated in this experimental MW drying process at 915 MHz and was determined to be $7.72 \text{ kW} \cdot \text{kg}^{-1}$. It is speculated that the E_a calculated for this experiment was lower than the E_a calculated by Panda et al. (2017) due to the increased penetration depth of MW at 915 MHz

frequency which is correlated with increased energy absorption, which increases the rate at which water from the agricultural product is removed.

Table 4.5: Effective moisture diffusivities (D_{eff}), and activation energy (E_a) for microwave power levels of 2 and 3 kW at drying durations of 31.5 minutes (Microwave Specific Energy of 1.38 and 2.07 (kWh.[kg-DM]⁻¹) and microwave power level of 4 kW at drying duration of 21.5 minutes (Microwave Specific Energy of 1.89 (kWh.[kg-DM]⁻¹) with a 915 MHz microwave

Power (kW)	Drying Duration (min)	Microwave Specific Energy (kWh.[kg-DM] ⁻¹)	D_{eff} (m ² .s ⁻¹)	E_A (kW.kg ⁻¹)
2	31.5	1.38	8.40×10^{-10}	3.02
3	31.5	2.07	1.40×10^{-9}	
4	21.5	1.89	1.79×10^{-9}	

CONCLUSION

The objective of this study was to investigate the heat and moisture transport phenomena in high-MC, long-grain parboiled rice kernels of cultivar XL753 exposed to MW heating at the 915 MHz frequency. The rough rice surface temperature immediately after parboiling was determined to be 54.73 °C. The parboiling process increased the rough rice MC from 32% to 55.61%. The MW specific energy to dry parboiled rough rice at MC of 55.61% to the desired *FMC* for safe storage and marketability (14.29 to 15.61% d.b.) with 2 kW of MW power, in one pass was 1.38 kWh.[kg-DM]⁻¹ for which the drying duration was 31.5 mins. Although applying MW power of 3 kW for drying duration of 21 mins or MW power of 4 kW for drying duration of 15.75 mins (MW specific energy of 1.38 kWh.[kg-DM]⁻¹) would give *FMCs* meeting that in safe storage range (14.29 to 15.61%), the resulting specific powers were greater than 2.92 kW.[kg-DM]⁻¹ which, based on our preliminary studies, is the specific power that was determined to be

safe for preserving rice milling yields and quality characteristics. MW power levels of 2, 3 and 4 kW with drying durations of 31.5, 31.5 and 21.5 mins had drying constant of 0.05, 1.77 and 2.28 h^{-1} , respectively indicating an increasing trend that correlated with increasing power levels. Of the Page, Newton, Logarithmic, and Henderson & Pabis models, the logarithmic model best represented the MR profiles during MW drying of parboiled rice kernels with $R^2 = 99.99 \times 10^{-2}$, Adjusted $R^2 = 99.99 \times 10^{-2}$, Reduced $\chi^2 = 1.88 \times 10^{-2}$ and $RMSE = 0.06 \times 10^{-2}$. The D_{eff} increased with increasing power levels. For example, at the power of 2, 3 and 4 kW the D_{eff} was 8.40×10^{-10} , 1.40×10^{-9} and $1.79 \times 10^{-9} \text{m}^2.\text{s}^{-1}$, respectively. The E_a associated with the MW drying process was determined to be $3.02 \text{kW}.\text{kg}^{-1}$. In summary, the ability to dry high-MC parboiled rough rice in one pass strongly justifies the need to optimize MW treatments to achieve commercially viable, MW-assisted parboiled rice drying process.

ACKNOWLEDGMENTS

This study was based upon work that is supported, in part, by the United States Department of Agriculture National Institute of Food and Agriculture Hatch Act Funding and AMTEK Microwaves.

REFERENCES

- Akpinar, E. K., & Toraman, S. (2016). Determination of drying kinetics and convective heat transfer coefficients of ginger slices. *Heat and Mass Transfer*, 52(10), 2271-2281.
- Alibas, I. (2010). Determination of drying parameters, ascorbic acid contents and color characteristics of nettle leaves during microwave-, air-and combined microwave-air-drying. *Journal of Food Process Engineering*, 33(2), 213-233.
- Aregbesola, O. A., Ogunsina, B. S., Sofolahan, A. E., & Chime, N. N. (2015). Mathematical modeling of thin layer drying characteristics of dika (*Irvingia gabonensis*) nuts and kernels. *Nigerian Food Journal*, 33(1), 83-89.
- Atungulu, G. G., Smith, D. L., Wilson, S. A., Zhong, H., Sadaka, S., & Rogers, S. (2016). Assessment of one-pass drying of rough rice with an industrial microwave system on milling quality. *Applied Engineering in Agriculture*, 32(3), 417-429.
- Babalís, S. J., & Belessiotis, V. G. (2004). Influence of the drying conditions on the drying constants and moisture diffusivity during the thin-layer drying of figs. *Journal of food Engineering*, 65(3), 449-458.
- Berruto, R., Busato, P., De la Torre, D., & Bartosik, R. (2011). Logistics and economics of rice harvest and post-harvest operations with the use of low temperature in-bin drying system. In 2011 Louisville, Kentucky, August 7-10, 2011 (p. 1). American Society of Agricultural and Biological Engineers.
- Crank, J. (1979). *The mathematics of diffusion*. Oxford university press.
- Das, I., Das, S. K., & Bal, S. (2003). Determination of the mixing index of paddy grains under vibrating conditions. *Journal of food process engineering*, 26(2), 121-133.
- Demiray, E., Seker, A., & Tulek, Y. (2017). Drying kinetics of onion (*Allium cepa* L.) slices with convective and microwave drying. *Heat and Mass Transfer*, 53(5), 1817-1827.
- Doymaz, İ., & İsmail, O. (2011). Drying characteristics of sweet cherry. *Food and bioproducts processing*, 89(1), 31-38.
- Ertekin, C., & Yaldiz, O. (2004). Drying of eggplant and selection of a suitable thin layer drying model. *Journal of food engineering*, 63(3), 349-359.
- Fernando, W. J. N., Ahmad, A. L., Shukor, S. A., & Lok, Y. H. (2008). A model for constant temperature drying rates of case hardened slices of papaya and garlic. *Journal of Food Engineering*, 88(2), 229-238.
- Fathi, M., Roshanak, S., Rahimmalek, M., & Goli, S. A. H. (2016). Thin-layer drying of tea leaves: Mass transfer modeling using semi-empirical and intelligent models. *International Food Research Journal*, 23(1), 40.

- Henderson, S. M., & Pabis, S. (1961). Grain drying theory I: Temperature effect on drying coefficient. *Journal of Agricultural Engineering Research*, 7, 85–89.
- Jindal, V. K., & Siebenmorgen, T. J. (1987). Effects of oven drying temperature and drying time on rough rice moisture content determination. *Transactions of the ASAE*, 30(4), 1185-1192.
- Kaushal, P., & Sharma, H. K. (2013). Convective dehydration kinetics of noodles prepared from taro (*Colocasia esculenta*), rice (*Oryza sativa*) and pigeonpea (*Cajanus cajan*) flours. *Agricultural Engineering International: CIGR Journal*, 15(4), 202-212.
- Khair, R., Pan, Z., Salim, A., Hartsough, B. R., & Mohamed, S. (2011). Moisture diffusivity of rough rice under infrared radiation drying. *LWT-Food Science and Technology*, 44(4), 1126-1132.
- Leethanapanich, K. (2015). Impacts of feedstock and parboiling conditions on quality characteristics of parboiled rice.
- Lewis, W. K. (1921). The rate of drying of solids materials. *Industrial Engineering Chemistry*, 13, 427.
- Luh, B. S. (Ed.). (1991). *Rice, Volume 2: Utilization (Vol. 2)*. Springer Science & Business Media.
- Lyman, N. B., Jagadish, K. S., Nalley, L. L., Dixon, B. L., & Siebenmorgen, T. (2013). Neglecting rice milling yield and quality underestimates economic losses from high-temperature stress. *PloS one*, 8(8).
- Metaxas, A. A., & Meredith, R. J. (1983). *Industrial microwave heating (No. 4)*. IET.
- Mujumdar, A. S., & Devahastin, S. (2008). *Guide to Industrial Drying: Principles, Equipments & New Developments*.
- Olatunde, G. A., Atungulu, G. G., & Smith, D. L. (2017). One-pass drying of rough rice with an industrial 915 MHz microwave dryer: Quality and energy use consideration. *Biosystems engineering*, 155, 33-43.
- Ondier, G. O., Siebenmorgen, T., & Mauromoustakos, A. (2012). Drying characteristics and milling quality of rough rice dried in a single pass incorporating glass transition principles. *Drying technology*, 30(16), 1821-1830.
- Özbek B, Dadali G (2007) Thin-layer drying characteristics and modelling of mint leaves undergoing microwave treatment. *Journal of Food Engineering*, 83:541–549
- Page, G. E. (1949). Factors Influencing the Maximum Rates of Air Drying Shelled Corn in Thin layers.

- Panda, B. K., Khan, S., Nagvanshi, S., & Shrivastava, S. L. (2017). Kinetics of Parboiled Paddy under Microwave Drying. *Current Journal of Applied Science and Technology*, 1-11.
- Perkin, R. M. (1980). The drying of porous materials with electromagnetic energy generated at radio and microwave frequencies. *Progr. Filtration Separation* 3:205-266.
- Prakash, B. (2011). *Mathematical Modeling of Moisture Movement within a Rice Kernel during Convective and Infrared Drying* (Doctoral dissertation, University of California, Davis).
- Smith, D. L., & Atungulu, G. G. (2018). Impact of drying deep beds of rice with microwave set at 915 MHz frequency on rice microbial community responses. *Cereal Chemistry*, 95(1), 130-140.
- Standish, N., Worner, H., & Kaul, H. (1988). Microwave drying of brown coal agglomerates. *Journal of microwave power and electromagnetic energy*, 23(3), 171-175.
- Tarafdar, A., Shahi, N. C., & Singh, A. (2019). Freeze-drying behaviour prediction of button mushrooms using artificial neural network and comparison with semi-empirical models. *Neural Computing and Applications*, 31(11), 7257-7268.
- Wimberly, J. E. (1983). Parboiling. *Technical Hand Book for the Paddy Rice Post Harvest Industry in Developing Countries*, 101-116.
- Yağcıoğlu, A., Değirmencioğlu, A., & Çağatay, F. (1999). Drying characteristics of laurel leaves under different drying conditions. In *7th Int Congress on Agricultural Mechanization and Energy* (pp. 565-569).
- Zanoelo, E. F., Di Celso, G. M., & Kaskantzis, G. (2007). Drying kinetics of mate leaves in a packed bed dryer. *Biosystems Engineering*, 96(4), 487-494.

CHAPTER 5: ENERGY USE ASSOCIATED WITH ONE-PASS DRYING OF PARBOILED ROUGH RICE WITH MICROWAVES AT 915 MHZ

ABSTRACT

Despite recent advances with conventional heated-air rice drying, it remains difficult to completely eliminate the drying-induced intra-kernel rice material state gradients, which are largely responsible for head rice yield (HRY) reduction. It is even more difficult to eliminate these gradients without multiple drying passes that disproportionately lead to extended drying durations and increased drying-energy expenditure. Volumetric heating with microwave (MW) energy at 915 MHz frequency has the potential to achieve one-pass parboiled rough rice drying while reducing development of the intra-kernel state gradient in the process which thereby improves HRY recovery. Although to the rice industry this would represent a great breakthrough, it is essential to examine MW energy use associated with the process of attaining the one-pass drying of parboiled rough rice. In this study, MW treatments of parboiled rough rice were conducted at a select power for various durations. The temperature changes of the parboiled rough rice during the treatments, and energy requirements to dry the parboiled rough rice to safe storage moisture content (MC) were evaluated. In addition, variation of the rice milling yields during the treatments were investigated. Specifically, freshly-harvested rough rice with initial MC of 31.58% dry basis (d.b.) was parboiled by soaking in a hot water bath set at 76 °C for 3 hours followed by high pressure steaming at 113 °C (67 kPa) for 10 mins which raised the parboiled rough rice MC to 55.96% d.b. The parboiled rough rice was then dried in a pilot-scale 915 MHz MW dryer. The dryer was set to transmit MW power of 2 kW. The energy required to dry the parboiled rough rice from 55.96% down to 15.58% d.b. MC was determined to be 1050 kWh per ton of high-MC

parboiled rough rice; at the studied treatment power, the total drying duration lasted 0.525 hours. The energy efficiency associated with the treatment was determined to be 18.89%. The maximum grain surface temperature recorded during the treatment was 92.61 °C. The HRY after the one-pass drying was 59.98%. Although one-pass MW drying of parboiled rough rice was feasible and may simplify the many stages involved in conventional parboiled rough rice drying with rotary and cross-flow dryers, it is important to optimize the MW energy delivery system to improve the process efficiency if the new approach is to be competitive for implementation by the rice industry.

Keywords: One-pass drying, 915 MHz microwave, milling yields, parboiled rough rice, energy requirement, drying efficiency

INTRODUCTION

Parboiled rice is rice that has been subjected to hydrothermal treatment prior to milling. Traditional parboiling operation involves soaking in water, steaming, and drying (Bhattacharya 2004). The process could be simplified by a new technology that combines all these steps into one. The current parboiling operation consumes more than 90% of the total energy required in a rice milling system (Islam et al. 2004). Kalchik et al. (1981) reported on a parboiled rough rice drying operation that used a high temperature column dryer to dry a ton of high moisture content (MC) parboiled rough rice. The energy requirement was calculated to be in the range of 489 kWh to 632 kWh to dry a ton of parboiled rough rice from an initial MC of 53.85% to 18.34% dry basis (d.b). Kasmaprapruet et al. (2009) reported that the drying step alone was the most energy-intensive unit operation in a rice milling system, accounting for approximately 55% of the total energy consumed.

The commercial rice milling industry uses cross-flow dryers and rotary dryers in combination and at different temperatures to dry high-MC parboiled rough rice. Rotary dryers are used to partially dry parboiled rough rice before loading it into the cross-flow dryer. Rotary dryers require drying air temperatures of up to 100°C (Wimberly, 1983). During drying, the moisture removal takes place rapidly in the first stage of drying when the parboiled rough rice is at MC range of 56.25 to 21.95% d.b (henceforth MC is in % dry basis); this is when a lot of the water is at the surface of the parboiled rough rice kernel. After the parboiled rice is partially dried in a rotary dryer, it is then transported to a cross-flow dryer to complete the drying process. Drying air temperatures of up to 75°C are used in cross-flow dryers (Wimberly, 1983). Between drying periods, rice millers employ a tempering step by stopping the drying process at about 21.95% MC to allow the parboiled rough rice MC to equilibrate for several hours before continuing the drying to 16.28%.

Atungulu et al. (2016) demonstrated the feasibility of using an industrial-type microwave (MW) heating system to achieve one-pass drying of freshly-harvested medium-grain rough rice. The authors found that the volumetric heating and the high heat flux accorded by the MWs were able to attain one-pass rough rice drying of freshly-harvested, high MC rice (26.58%) to safe storage MC (14.94%) while maintaining the head rice yield (HRY). Olatunde et al. (2017) investigated the use of industrial MW at 915 MHz frequency for drying of freshly-harvested rough rice with an emphasis on energy use. The authors found that the specific energies of 0.17 kWh.[kg-grain]⁻¹ and 0.21 kWh.[kg-grain]⁻¹ were able to dry freshly-harvested rough rice from 31.58% to 14.29% in one pass. Their energy analysis determined that at these MW specific energies, 1.27 kWh and 1.66 kWh were required per kg of water removed, respectively. However, the previous authors did not report how the process may apply in drying of parboiled rough rice. Following

parboiling, the high MC rough rice (typically 53.85-66.67%) need to be dried as soon as possible to the safe storage MC range of 14.29-15.61%.

The present research aims to investigate the energy use and drying efficiency associated with MW drying of parboiled rough rice at a selected power (2 kW) that was found in preliminary studies to result in specific power favorable for maintaining high rice milling yield and milled rice quality characteristics. The changes in the parboiled rough rice surface temperature and milling yields profiles were also recorded. The ability to dry high MC parboiled rough rice in one pass with preserved HRYs could boost financial returns of rice producers and processors. At present, there is no commercial use of MW technology for parboiled rough rice drying in the USA; there is a lack of documented energy analysis of the process.

METHODS

Freshly-harvested, long-grain rough rice samples of cultivar XL753 at MC of 31.58 % were used in this study. The samples were cleaned using dockage equipment (MCi Kicker Dockage Tester, Mid-Continent Industries Inc., Newton, KS). The equipment uses a series of small-sized sieves to provide a fast, accurate, and consistent way of separating shrunken, broken, scalped material, broken kernels, splits, and dust from the rough rice. The cleaned rough rice samples were stored in a laboratory cold room set at 4°C. At the beginning of the experiments, the samples were retrieved from the cold room and allowed to equilibrate with room temperature (25 °C) overnight before conducting any experiments. The MCs of the samples that were reported in this study were determined using an AM 5200 Grain Moisture Tester (PERTEN Instruments, Hägersten, Sweden), which is calibrated according to Jindal and Siebenmorgen (1987). The final MC (*FMC*) of each sample was validated using the oven method by placing 15 g duplicate samples into a conduction

oven (Shellblue, Sheldon Mfg., Inc., Cornelius, OR) set at 130 °C for 24 h, followed by cooling in a desiccator for at least half an hour (Jindal and Siebenmorgen, 1987).

Parboiling Procedure

To determine the appropriate soaking temperature for rough rice parboiling, it was necessary to determine the onset gelatinization temperature of the rice cultivar used in the experiment. This was done using differential scanning calorimetry. Rough rice at MC of 14.29% was milled then ground into flour using a cyclone mill with a 0.5 mm sieve (Model 2511, UDY Corp., Fort Collins, CO., USA). An 8 mg sample of rice flour was weighed into an aluminum pan, and 16 µL of deionized water was added. The aluminum pan was hermetically sealed and equilibrated for 1 h before scanning from 25 to 120 °C at 10 °C per minute using a Differential Scanning Calorimeter (PyrisDiamon, Perkin-Elmer Co., Norwalk, CT, USA). Thermal properties, including onset, peak, and end gelatinization temperature and enthalpy, were determined in duplicate.

Following the determination of the thermal properties, rough rice samples were prepared (3 reps, 1000 g each) and placed into a 45 cm by 45 cm piece of cheesecloth then allowed to soak for 3 h in a lab-scale hot water bath set to soaking temperature slightly below the determined onset gelatinization temperature (this was specific to the rice cultivar, XL753). After soaking, the wet rough rice still in the cheesecloth was steamed for 10 mins in a lab-scale autoclave set to a pressure of 67 kPa and a corresponding temperature of 113 °C. After, the parboiling the samples were immediately treated with MW.

Microwave Equipment and Treatment

The MW (AMTek, Applied Microwaves Technology Inc., Cedar Rapids, IW) used in this research was designed for high power operations (up to 75 kW) and had a frequency of 915 MHz. The system consists of a transmitter, a wave-guide, and the MW heating zone (oven). The transmitter is a high-powered vacuum tube that works as a self-excited MW oscillator. It is used to convert high-voltage electric energy to MW radiation. The wave-guide consists of a rectangular pipe through which the electromagnetic field propagates lengthwise. It is used to transport MW power from the magnetron into the lab oven. The lab oven is the internal cavity of the MW that provides uniform MW heating throughout while in use.

For each MW treatment, freshly-parboiled rough rice samples (1000 g) were placed into MW safe trays for treatments. The parboiled rough rice bed thickness was 3 cm. The outsides of the trays are made of polypropylene with a Teflon coated fiberglass mesh at the bottom to hold the samples. The trays with parboiled rough rice samples were set in the oven on the belt and treated (Figure 5.1). The parboiled rough rice surface temperature during MW heating was measured using fiber optic temperature sensors (OMEGA Engineering, INC., Stamford, CT., USA). After MW treatments, the parboiled rough rice samples were transferred immediately to glass jars and sealed airtight for tempering. The jars were placed in an incubator (VWR General Purpose Incubator 1536, Sheldon Manufacturing Inc., Cornelius, OR., USA) set at a temperature of 60 °C. The parboiled rough rice was tempered for 4 h. After the tempering, the parboiled rough rice was spread uniformly on individual trays, and then transferred to an EMC chamber (Platinous chamber, ESPEC North America, Inc. Hudsonville, MI., USA) set at a temperature of 26 °C and RH of 65%.

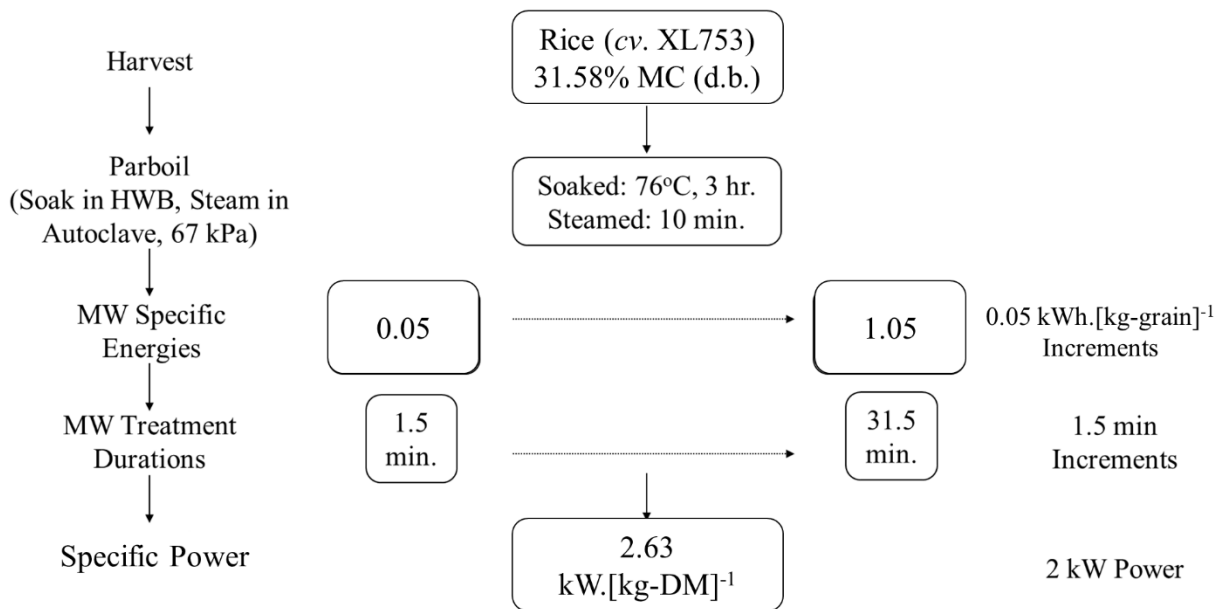

Figure 5.1: Experiment process flow diagram; *cv.*, d.b., HWB, MW, and MC indicates cultivar, dry basis, hot water bath, microwave, and moisture content, respectively; kg-DM indicates kg of dry matter; d.b. indicates dry basis.

In case of control experiments, the rough rice samples were parboiled in a manner similar to the procedures previously described; following parboiling, the rough rice samples were immediately transferred to glass jars and sealed airtight for tempering. The jars were placed in an incubator (VWR General Purpose Incubator 1536, Sheldon Manufacturing Inc., Cornelius, OR., USA) set at a temperature of 60 °C. The parboiled rough rice was tempered for 4 h. After the tempering, the parboiled rough rice was spread uniformly on individual trays, and then transferred to an equilibrium moisture content (EMC) chamber (Platinous chamber, ESPEC North America, Inc. Hudsonville, MI., USA) set at a temperature of 26 °C and relative humidity (RH) of 65%. The control samples are considered to be dried the gentlest and therefore are expected to result in the best attainable HRY and rice quality which are compared with results obtained from the studied MW treatments.

Drying Energy and Efficiency Determination

MW specific energy was defined as the energy transferred per unit mass of product treated. For this research, the reference mass (m) was set as the initial wet mass of the grain (before the commencement of the MW treatment, and mass unit expressed as kg-grain). The MW specific energy was calculated as follows:

$$Q_s = \frac{p \times t_d}{m \times 3600} \quad (1)$$

Where:

Q_s is the MW specific energy (kWh.[kg-grain]⁻¹)

p is the electrical power supplied to the MW (kW)

t_d is the drying duration (s)

m is the initial wet mass of product being treated (kg-grain)

The theoretical energy consumption during the drying process per kg of wet grain mass (kWh. [kg-grain]⁻¹) was calculated as:

$$Q = (m_{dw} C_{p_{rice}} \Delta\theta_s) + (m_w C_{p_w} \Delta\theta_s) + (m_w \lambda_w) \quad (2)$$

Where:

Q is the energy consumption of MW drying (kWh. [kg-grain]⁻¹)

m_w is the mass of water removed (kg)

m_{dw} is the mass of the sample after water was removed (kg)

$C_{p_{rice}}$ is the specific heat capacity of the parboiled rough rice, 6.45×10^{-4} kWh.[kg. °C]⁻¹

$\Delta\theta_s$ is the change in parboiled rough rice surface temperature during drying (°C)

C_{p_w} is the specific heat capacity of water, 1.16×10^{-3} kWh.[kg. °C]⁻¹

λ_w is the latent heat of vaporization of water, 0.63 kWh.[kg]⁻¹

The MW drying efficiency was calculated as following (Soysal et al., 2006):

$$\eta = \frac{Q}{Q_s} \quad (3)$$

Where:

η is the drying efficiency (%)

Q is the theoretical drying energy per kg of wet grain mass (kWh. [kg-grain]⁻¹)

Q_s is the MW energy input per kg of wet grain mass (kWh. [kg-grain]⁻¹)

Rice Milling

Triplicate, 150 g subsamples of parboiled rough rice, obtained from each sample dried to 14.29% MC, were dehulled using a laboratory huller (Satake Rice Machine, Satake Engineering Co., Ltd., Tokyo, Japan), milled for 30 s using a laboratory mill (McGill #2 Rice Mill, RAPSCO, Brookshire, TX., USA) and aspirated for 30 s using a seed blower (South Dakota Seed Blower, Seedboro, Chicago, IL., USA). MRY was calculated as the mass proportion of parboiled rice that remains, including head rice and broken, after milling. Head rice was then separated from broken kernels using a double tray sizing machine (Grainman Machinery Manufacturing Corp., Miami, FL., USA). Head rice is considered as kernels that remain at least three-fourths of the original kernel length after complete milling (Siebenmorgen, 2014). HRY was calculated as the mass proportion of parboiled rice that remains as head rice after complete milling.

Statistical Analysis

Statistical analyses using the Fit Model platform of JMP Pro (JMP Pro Version 15.1.0, SAS Institute). Standard least squares multiple regression models were using linear quadratic and two-way interactions among the predictors and to determine significant differences. The best

predictors were selected using p -value (<0.05) to evaluate which independent variables (predictors) best-explained variations of continuous responses (dependent variables.)

RESULTS AND DISCUSSION

Parboiling Conditions of Soaking Temperature

The onset, peak, and end gelatinization temperatures were determined to be 76.4, 81.7, and 89.0 °C, respectively. Consequently, for this research the rough rice was soaked at 76 °C. Leethanapanich (2015) indicates that there is a more pronounced increase in HRY for parboiled rough rice when the soaking temperature was closer to the onset gelatinization temperature. Cnossen et al., (2003) proposed that the increase in HRY was as a result of reduction of fissured kernels that may break during milling (Cnossen et al., 2003). HRY reduces when soaking is done above the onset gelatinization temperature due to excessive swelling of starch after gelatinization, leading to husk splitting (Bhattacharya and Subba Rao, 1966).

Moisture and Temperature Profiles

Kinetics of parboiled rough rice MC during drying is shown in figure 5.2. Based on the experimental data, the *FMC* could be predicted using the following equation ($R^2=0.93415$; Adjusted $R^2=0.931955$; $RMSE = 2.009613$; $p = <.0001$):

$$FMC (\% d.b.) = 42.24 + 13.33 Q_s + 9.93 Q_s^2 \quad (4)$$

Where Q_s is the MW specific energy ($kWh.[kg-grain]^{-1}$). The changes in *FMC* following the MW treatments were statistically significant ($p < 0.0001$) with increasing MW specific energy. The observed trends agree with a study by Smith & Atungulu, (2018) and Al-Harabsheh, Ala'a, & Magee (2009).

The surface temperature of the rough rice immediately after parboiling was determined to be 54.73 °C (SD = 0.79 °C). As the drying duration increased, so did the parboiled rice surface temperature increase. The parboiled rice surface temperature was 92.61 °C (SD = 0.46 °C) after 31.5 mins of the MW drying (Figure 5.2). The changes in parboiled rice surface temperature profiles exhibited three distinct phases (I, II, and III), significantly ($p < 0.05$) increased with drying duration, could be predicted using equations in Table 5.1. Atungulu et al. (2016) found that the surface temperature of rough rice increased when the MW power level and drying duration increased. In the authors' study, the initial surface temperature of the rough rice at 17.5 °C increased to 50°C, 80°C, and 95°C when the rough rice was heated with MW at the power level of 5 kW for 1, 2, and 3 mins, respectively.

Table 5.1: Summary of fit table showing the surface temperature of parboiled rough rice (55.96 MC%, dry basis) during microwave drying with a microwave at 915 MHz frequency; t_d is the drying duration (min); θ_s is parboiled rough rice surface temperatures (°C).

	Drying Phase I $\theta_s = f(0 \leq t_d \leq 4.5)$	Drying Phase II $\theta_s = f(4.5 \leq t_d \leq 10.5)$	Drying Phase III $\theta_s = f(10.5 \leq t_d \leq 31.5)$
Prediction Expression	$\theta_s = 43.36 + 7.74(t_d)$	$\theta_s = 23.91 + 7.32(t_d) - 0.03(t_d)^2$	$\theta_s = 76.82 - 0.42(t_d) + 0.03(t_d)^2$
R-Square	0.998736	0.998373	0.99717
Adjusted R-Square	0.998556	0.998102	0.997035
Root Mean Square Error	0.382184	0.036956	0.306368
P-Value	<.0001	<.0001	<.0001

It was noted in our experiments that the parboiled rough rice surface temperature did not exceed 92.61 °C. Feng and Tang (1998) observed similar trends in the study which used a MW at

2450 MHz frequency to dry diced apples in a spouted bed. The researchers found that there was a slight temperature reduction towards the end of the drying process. The authors suggested that this temperature reduction was due to the decrease in moisture of the diced apples. Thus, sample temperatures were slightly reduced due to the combined effects of evaporative cooling and heat transfer from the sample to air. Evaporative cooling is the reduction in temperature resulting from the evaporation of a liquid, which removes latent heat from the surface from which evaporation takes place. Atungulu et al. (2016) and Gunasekaran (1990) found that the surface temperature of the drying grain decreased due to moisture evaporating continuously from the grain surface because of this evaporative cooling effect. Evaporative cooling effects were also observed by Adu, Otten and Brown (1994) in their MW drying tests of soybeans.

In phase II of the parboiled rice surface temperature profile, temperature steadily decreased quadratically from 77.94 °C to 75.69 °C (SD = 0.49 °C). The parboiled rice surface temperature at the start of the phase II (77.94 °C) is almost directly at the midpoint between the onset and peak gelatinization temperature of 76.4 and 81.7 °C, respectively. Parboiling was conducted slightly below the onset gelatinization temperature (76 °C). Although steaming was conducted at 113 °C which was well above the peak gelatinization temperature, this temperature was only held for 10 mins. As a result, it is quite possible that the rice did not fully gelatinize during parboiling, and the reduction in parboiled rice surface temperature during the MW drying process as observed in phase II, was due to the rice starches completing gelatinization. The behavior of starch at the gelatinization temperature affects the availability of free water due to its absorption by the swelling starch granules. Since water works as a plasticizer during glass transition and gelatinization of food materials, the process of gelatinization is expected to affect the dielectric properties of rice starch during heating. Ahmed et al. (2007), whose research aimed at determining the dielectric

properties of Indian Basmati rice samples processed at a frequency range of 500 to 2500 MHz indicated that the dielectric loss factor of the rice kernels showed an increasing trend as the initial rice surface temperatures increased from 30 to 70 °C. However, the researchers indicated that there was a sharp decrease in dielectric parameters, and by extension, the rate of surface temperature increase above the rice gelatinization temperature of 70 °C. Chungcharoen & Lund (1987) also observed this phenomenon in rice flours and their isolated starch components.

In phase III of the parboiled rice surface temperature profile, the parboiled rice surface temperature increased quadratically from 75.69 °C to 92.61 °C (SD = 0.46 °C). This trend is consistent with trends expected with the continuous heating of high dielectric loss materials that is not undergoing gelatinization.

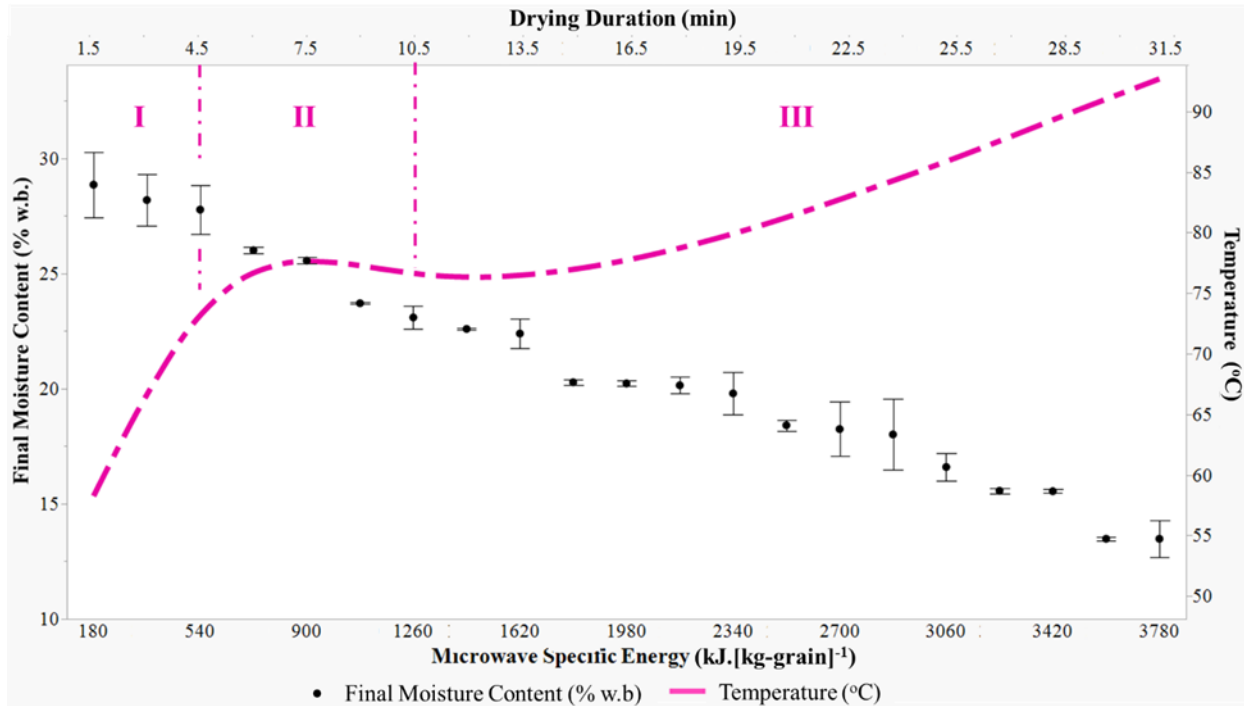

Figure 5.2: Parboiled rough rice moisture content and surface temperature kinetics during microwave drying with a microwave at 915 MHz frequency as a function of drying duration (treatment power was 2 kW, initial product mass was 1 kg, and the initial moisture content of the parboiled rough rice was 55.96%); d.b. indicates dry basis.

Drying Energy Requirement and Efficiency

Parboiled rough rice kernels are considered high dielectric loss materials due to their ability to absorb MW energy. As a result, when placed in a MW field, the parboiled rough rice kernels absorb MW energy, and this energy is subsequently converted into heat through the molecular vibration of the polar molecules and friction (Fan et al., 2017). In our study, MW specific energy of 1.05 kWh.[kg-grain]⁻¹ was required to dry the parboiled rough rice from an initial MC of 55.96% to 15.58%. This translates to 1050 kWh per ton of the initial mass of rough rice at MC of 55.96%. This energy can be translated to 4.04 kWh.[kg-H₂O removed]⁻¹ and 1416.81 kWh to produce a ton of parboiled rough rice at an MC of 15.58%. Olatunde et al. (2017) reported that the energy requirement to remove a kg of water from freshly-harvested rough rice samples from 31.58% to

14.29% in one pass using an industrial MW at 915 MHz frequency at the MW specific energy of 0.21 kWh.[kg-grain]⁻¹ was 1.66 kWh.[kg-H₂O removed]⁻¹. This energy requirement by Olatunde et al. (2017) was 2.43 times lower than the energy requirement to remove a kg of water calculated for this research in large part because the researcher dried freshly-harvested rice in contrast with parboiled rice which is considered in our experiment. The parboiling process induces the rice starch's gelatinization, whereby breaking down of the intermolecular bonds of starch molecules in the presence of water and heat to allow the hydrogen bonding sites (the hydroxyl hydrogen and oxygen) to engage more water. As a result, it is expected that more energy would be needed to break the water bound to the hydrogen binding sites of starch in parboiled rough rice kernels compared to the unbound water found in freshly-harvested rough rice kernels.

Based on the “commercial energy” rates in the state of Arkansas in the U.S.A. (8.41 cents per kWh), the cost to dry a ton of high-MC parboiled rough rice from an initial MC of 55.96% to 15.58% would be estimated at \$88.31. Kalchik et al. (1981) reported on a parboiled rough rice drying operation that used a high temperature column batch dryer supplying air at 165 m³/min per ton of high MC parboiled rough rice. The energy requirement was calculated to be 632 kWh to dry a ton of parboiled rough rice from an initial MC of 53.85% to 18.34%. This translates to a drying cost of \$53.15 per ton of high-MC parboiled rough rice. The cost and energy calculated by Kalchik et al. (1981) was 1.66 times lower than that of the cost to dry a ton of high-MC parboiled rough rice calculated for this research. Kalchik et al. (1981) also reported on a parboiled rough rice drying operation that used a high temperature continuous flow column dryer supplying air at 110 m³/min per ton of high-MC parboiled rough rice. The energy requirement was calculated to be 489 kWh to dry a ton of parboiled rough rice from an initial MC of 53.85% to 18.34%. This translates to a drying cost of \$41.12 per ton of high-MC parboiled rough rice; the cost and energy calculated

was 2.15 times lower than that determined in our research. It should be noted that the energy used to dry parboiled rough rice can vary considerably depending on many factors including the type and variety of grain, drying air temperature, RH, airflow rate (and thus drying rate), and the initial and final MC of the parboiled rough rice (Simmonds et al., 1953; Henderson & Pabis, 1961; Otten, 1980; Cenkowski et al., 1992; Cnossen et al., 2002; Mulet et al., 1999; Iguaz et al., 2003; Aviara et al., 2004; Toğrul & Arslan, 2006).

The drying efficiency determined in this experiment was 18.89%. In part, the determined efficiency is low because in calculation of the theoretical energy, it assumed that the latent heat of vaporization of water is same as that on a free surface, $0.63 \text{ kWh} \cdot [\text{kg}]^{-1}$. In reality the water is being evaporated from parboiled rice, which due to gelatinization the water is more bound to the hydrogen bonding sites of starch thereby requiring higher energy to remove. Theoretical energy consumption calculated for 100% and 80% efficiencies to dry a ton of parboiled rough rice from 55.96% to 15.58% is 198.30 kWh and 247.90 kWh, respectively; this translates to \$16.68 and \$20.85, respectively, per ton of parboiled rough rice. If we were to assume that the latent heat of vaporization was 2.43 times higher for parboiled rice drying as indicated by the energy requirement calculated by Olatunde et al. (2017) who dried freshly-harvested rice the efficiency would increase to 41.27%. Theoretical energy consumption calculated for 41.27% efficiency to dry a ton of parboiled rough rice from 55.96% to 15.58% would be 433.29 kWh; this translates to \$36.40 per ton of parboiled rough rice.

Although the MW drying duration in our experiment was tremendously shorter than that of conventional industrial practice, there is still room and need to optimize the process to drive down the energy cost. Opportunity exists to optimize the energy required to below those using conventional means by accurately measuring and quantifying dielectric properties of parboiled

rough rice of different cultivars and characteristics such as MC; use this information for mathematical modeling to simulate use of different MW applicators and susceptors; describe parboiled rough rice kernel material state transitions during MW heating processes at various power densities and frequencies; and based on the generated information design, fabricate and validate the performance of new optimized MW applicators, MW susceptors, and MW processing conditions.

Post-Drying Rice Characteristics

The MRY of control samples was determined to be 70.14%, and HRY was 67.86%. The kinetics of MRY and HRY changes during the treatments are shown in figure 5.3. The summary of fit table showing the effect of MW drying duration on the MRY and HRY of parboiled rough rice dried is shown in Table 5.2. The MRY and HRY responses had a statistically significant change ($p < 0.05$) as a result of increasing drying duration (Table 5.2).

The increased surface temperatures and drying rates induced by MW drying contributed to increased MC gradients within the rice kernels, subsequently leading to the formation of fissures. The formation of fissures within the kernel is a consequence of the differential shrinking and swelling of the endosperm, which results from uneven dehydration of the rice kernel during rapid drying when the grain is losing moisture to the drier outer layers (Nagato et al., 1964; Kunze & Hall, 1967; Kobayashi et al., 1972; Schluterman and Siebenmorgen, 2007). The presence of fissures on a rice kernel makes it more susceptible to breakage during the subsequent hulling and milling processes and is correlated with decreases in milling yields (Rhind, 1962; Craufurd, 1963; Kunze & Choudhury, 1972; Kobayashi, Miwa & Ishikowa, 1972; Kunze, 1979; Fernando et al., 2008; Smith & Atungulu, 2018; Smith et al., 2018).

Table 5.2: Summary of fit table showing the effect of microwave drying duration on the milled rice yields (MRY), and head rice yields (HRY) of parboiled rough rice during microwave drying at a frequency of 915 MHz

	MRY	HRY
R-Square	0.222049	0.432959
Adjusted R-Square	0.202601	0.418783
Root Mean Square Error	2.19895	2.869362
P-Value	0.0016	<.0001*

The MRY and HRY responses at the drying duration of 31.5 mins (power level of 2kW; MW specific energy of 1.05 kWh.[kg-grain]⁻¹) were 65.01% and 59.98%, respectively. The HRY obtained from the treatment is still some eight percentage points lower than control samples. It is possible to stop the MW treatments after a drying duration that gives competitive HRY. For instance, if the high MC parboiled rice was dried at drying duration of 10.5 min at the power level of 2 kW (MW specific energy of 0.35 kWh.[kg-grain]⁻¹ and the rest of the drying was completed with natural or hot air the parboiled rough rice MC would be 30.04%. The approach of pre-drying with MW may still significantly reduce drying duration, energy cost and result in HRY comparable to or greater than that of control samples. Under ideal conditions, a perfect HRY recovery would be about 70% of the total rough rice produced after the rice hulls and bran are removed (USDA, 2014; Atungulu et al. 2016). Therefore, the goal should be to get a HRY closest to 70%.

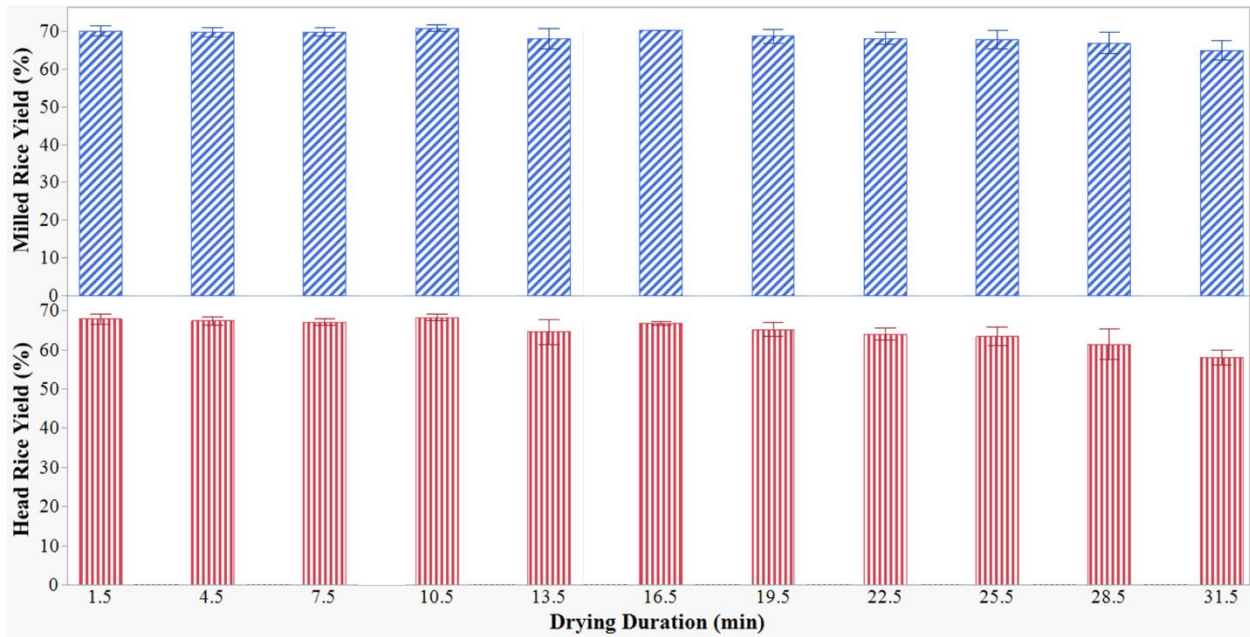

Figure 5.3: Effect of microwave drying duration on the milled rice yields, and head rice yields of parboiled rough rice during microwave drying with a microwave at 915 MHz frequency

CONCLUSION

The objective of this study was to investigate the energy use and drying efficiency associated with drying of parboiled rough rice with 915 MHz MW dryer. A MW power level of 2 kW was used to investigate specific energy and durations required to dry parboiled rough rice in one pass from parboiled rough rice MC to safe storage MC. The following conclusions were drawn:

- Following parboiling of the long-grain rough rice (XL 753) harvested at a MC of 31.58% d.b., the MC increased to 55.96%.
- The changes in parboiled rice surface temperature profiles exhibited three distinct phases characterized by an initial rapid linear increase in temperature, followed by a quadratic declining temperature speculated to result from starch gelatinization

process, and a final steady and quadratic increase in the grain temperature; the maximum grain surface temperature recorded during the treatment was 92.61 °C.

- MW specific energy of 1.05 kWh.[kg-grain]⁻¹ was required to dry the parboiled rough rice from initial MC of 55.96% down to 15.58% d.b.; this translated to a drying energy requirement of 1050 kWh per ton of high MC parboiled rough rice; and a drying efficiency of 18.89%. In general, the energy use was high and the process need to be optimized to be competitive for industrial implementation.
- The MRY and HRY associated with the one pass drying at specific energy of 1.05 kWh.[kg-grain]⁻¹ were 65.01% and 59.98%, respectively. The HRY obtained from the treatment was some eight percentage points lower than that of control samples which suggest that partial MW drying and finishing the drying to safe storage with gently air drying might be better for preserving the rice HRY. Therefore, it recommended to stop the MW treatments after a drying duration that gives competitive HRY (10.5 min) and complete the rest of drying with natural air. The approach of pre-drying with MW may significantly reduce drying duration, energy cost and result in high HRY that are comparable to or greater than that of control samples.

ACKNOWLEDGMENTS

This study was based upon work that is supported, in part, by the United States Department of Agriculture National Institute of Food and Agriculture Hatch Act Funding and AMTEK Microwaves.

REFERENCES

- Al-Harashsheh, M., Ala'a, H., & Magee, T. R. A. (2009). Microwave drying kinetics of tomato pomace: Effect of osmotic dehydration. *Chemical Engineering and Processing: Process Intensification*, 48(1), 524-531.
- Atungulu, G. G., Smith, D. L., Wilson, S. A., Zhong, H., Sadaka, S., & Rogers, S. (2016). Assessment of one-pass drying of rough rice with an industrial microwave system on milling quality. *Applied Engineering in Agriculture*, 32(3), 417-429.
- Aviara, N.A., Ajibola, O.O., Oni, S.A., 2004. Sorption equilibrium and thermodynamic characteristics of soya bean. *Biosystems Engineering* 87 (2), 179–190.
- Bhattacharya, K. R., (2004). Parboiling of rice. In: *Rice chemistry and technology*. Champagne ET, editor. St. Paul, Minn.: AACC Int. p 329–404
- Bhattacharya, K. R., & Subba Rao, P. V. (1966). Processing conditions and milling yield in parboiling of rice. *Journal of Agricultural and Food Chemistry*, 14(5), 473-475.
- Cenkowski, S., Jayas, D. S., & Hao, D. (1992). Latent heat of vaporization for selected foods and crops. *Canadian Agricultural Engineering*, 34(3), 281-286.
- Cnossen, A. G., Jimenez, M. J., & Siebenmorgen, T. J. (2003). Rice fissuring response to high drying and tempering temperatures. *Journal of food engineering*, 59(1), 61-69.
- Cnossen, A. G., Siebenmorgen, T. J., & Yang, W. (2002). The glass transition temperature concept in rice drying and tempering: effect on drying rate. *Transactions of the ASAE*, 45(3), 759.
- Craufurd, R.Q. (1963). Sorption and desorption in raw and parboiled paddy. *Journal of the Science of Food and Agriculture* 14(10):744-750.
- Das, I., Das, S. K., & Bal, S. (2004). Specific energy and quality aspects of infrared (IR) dried parboiled rice. *Journal of Food Engineering*, 62(1), 9-14.
- Fernando, W. J. N., Ahmad, A. L., Shukor, S. A., & Lok, Y. H. (2008). A model for constant temperature drying rates of case hardened slices of papaya and garlic. *Journal of Food Engineering*, 88(2), 229-238.
- Henderson, S. M., & Pabis, S. (1961). Grain drying theory I: Temperature effect on drying coefficient. *Journal of Agricultural Engineering Research*, 7, 85–89.
- Iguaz, A., Vírveda, P., 2007. Moisture desorption isotherms of rough rice at high temperatures. *Journal of Food Engineering* 79 (3), 794–802
- Islam, M. R., Shimizu, N., & Kimura, T. (2004). Energy requirement in parboiling and its relationship to some important quality indicators. *Journal of Food Engineering*, 63(4), 433-439.

- Jindal, V. K., & Siebenmorgen, T. J. (1987). Effects of oven drying temperature and drying time on rough rice moisture content determination. *Transactions of the ASAE*, 30(4), 1185-1192.
- Kalchik, S. J., Silva, J., Mwaura, E. N., Rodriguez, J. C., & Bakker-Arkema, F. W. (1981). On-farm corn drying comparison. Paper-American Society of Agricultural Engineers (Microfiche collection)(USA).
- Kasmaprapruet, S., Paengjuntuek, W., Saikhwan, P., & Phungrassami, H. (2009). Life Cycle Assessment of Milled Rice Production: Case Study in Thailand. *European Journal of Scientific Research*, 30(2), 195-203.
- Kobayashi, H., Miwa, Y., & Hayakawa, H. (1972). On the mechanism of the cracking in rice kernels during drying of paddies, particularly moisture distribution and drying strain in one kernel. *Research Bulletin 33: 279–293*. Gifu, Japan: Gifu University, Faculty of Agriculture
- Kobayashi, H., Miwa, Y., & Ishikowa, M. (1972). On the mechanism of cracking in rice kernels during drying of paddies particularly moisture distribution and drying strain in one kernel. *Research Bulletin of the Faculty of Agriculture of Gifu University*. 33: 279 - 293.
- Kunze, O. R. (1979). Fissuring of the rice grain after heated air drying. *Trans. ASAE* 22:1197-1202, 1207.
- Kunze, O. R., and Choudhary, M. S. U. (1972). Moisture adsorption related to the tensile strength of rice. *Cereal Chem* 49:684-696.
- Kunze, O. R., & Hall, C. W. (1967). Moisture adsorption characteristics of brown rice. *Transactions of the ASAE*, 10(4), 448-0450.
- Leethanapanich, K. (2015). Impacts of feedstock and parboiling conditions on quality characteristics of parboiled rice.
- Lyman, N. B., Jagadish, K. S., Nalley, L. L., Dixon, B. L., & Siebenmorgen, T. (2013). Neglecting rice milling yield and quality underestimates economic losses from high-temperature stress. *PloS one*, 8(8).
- Mulet, A., García-Reverter, J., Sanjuán, R., & Bon, J. (1999). Sorption isosteric heat determination by thermal analysis and sorption isotherms. *Journal of Food Science*, 64(1), 64-68.
- Nagato, K., Ebata, M., & Ishikawa, M. (1964). On the formation of cracks in rice kernels during wetting and drying of paddies. *Japanese Journal of Crop Science*, 33(1), 82-89.
- Otten, L. R. (1980). A study of a commercial cross-flow dryer. *Canadian Agric. Eng.*, 22(2), 163-170.

- Rhind, D. (1962). The breakage of rice in milling. A review. *Tropical Agriculture (Trinidad)* 39:19-28.
- Schluterman, D. A., & Siebenmorgen, T. J. (2007). Relating rough rice moisture content reduction and tempering duration to head rice yield reduction. *Transactions of the ASABE*, 50(1), 137-142.
- Siebenmorgen, T. (2014). Laboratory Measurement of Rice Milling Yield. University of Arkansas Division of Agriculture Cooperative Extension Service. Available at: <http://www.uaex.edu/publications/pdf/mp192>.
- Simmonds, W. H. C., Ward, G. T., & McEwen, E. (1953). The drying of wheat grain. Part I: The mechanism of drying. *Trans. Inst. Chem. Eng.*, 31(3), 265-278.
- Smith, D. L., & Atungulu, G. G. (2018). Impact of drying deep beds of rice with microwave set at 915 MHz frequency on the rice milling yields. *Innovative Food Science & Emerging Technologies*, 45, 220-227.
- Smith, D. L., Atungulu, G. G., Sadaka, S., & Rogers, S. (2018). Implications of microwave drying using 915 MHz frequency on rice physicochemical properties. *Cereal Chemistry*, 95(2), 211-225.
- Soysal, Y., Öztekin, S., & Eren, Ö. (2006). Microwave drying of parsley: modelling, kinetics, and energy aspects. *Biosystems Engineering*, 93(4), 403-413.
- Toğrul, H., & Arslan, N. (2006). Moisture sorption behaviour and thermodynamic characteristics of rice stored in a chamber under controlled humidity. *Biosystems Engineering*, 95(2), 181-195.
- USDA. (2014). Crop and stocks report. USDA-National Agricultural Statistics Service Arkansas. Retrieved from <http://www.nass.usda.gov/>

CHAPTER 6: PROJECT CONCLUSIONS

The performance of an industrial type microwave system for parboiled rough rice drying was tested. The microwave (MW) system was operated at a frequency of 915 MHz to dry high moisture content parboiled long grain rough rice samples of cultivar Mermentau (2018) and XL753 (2019) which were harvested at initial MC of 23% to 24% wet basis (w.b).

Long grain rough rice samples were placed into a 45 cm by 45 cm piece of cheesecloth then allowed to soak in a lab-scale hot water bath set to soaking temperature of 71, 73 and 76 °C for 3 hours. After soaking, the wet rough rice in cheesecloth was steamed in a lab-scale autoclave set to a temperature of 113 °C and a corresponding pressure value of 67 kPa for 5, 10 and 15 minutes to complete the parboiling process.

It was found that increasing soaking temperature from 71 °C to 76 °C led to increased uptake of water after parboiling, decreases in MRY, HRY, protein content, and SLC and increased TCD. Increasing steaming duration from 5 to 15 min led to decreased uptake of water by rice after the parboiling process, decreased MRY, protein content, SLC and TCD and increased HRY. It was recommended that for further parboiling research, rough rice is soaked at the onset gelatinization temperature, steamed for 10 min for optimal milling and physiochemical characteristics.

In preparation for MW drying, the parboiled rough rice was placed in a MW blind tray. The outsides of the trays were made of polypropylene plastic on the sides with a Teflon coated fiberglass mesh at the bottom to hold the rough rice samples. The trays with rough rice samples were set on the belt of the MW oven and treated at specific energies ranging from 100 to 5650 kJ.[kg-grain]⁻¹ for drying durations in the range of 1.5 to 31.5 minutes. It was determined that increasing the MW specific energy led to decreases in the parboiled rough rice FMC, protein content, surface lipid content, peak and setback viscosity.

Experiments conducted to determine the implications of MW specific power on parboiled rough rice determined that rough rice soaked at 73°C, steamed for 10 min then treated at a low specific power of 2.92 kW.[kg-DM]⁻¹ produced parboiled rough rice with FMC of 21.22%, drying rate of 3.85% d.b. [min⁻¹], MRY of 73.22%, and HRY of 72.37%. However, rough rice subjected to the same parboiling conditions but treated at higher specific power of 8.77 kW.[kg-DM]⁻¹ produced parboiled rough rice with FMC of 19.73%, drying rate of 12.29% d.b. [min⁻¹], MRY of 68.18%, and HRY of 67.51%. The findings suggest that an increased MW specific power has a positive effect on rice MC reduction but negatively effects the rice milling characteristics.

Experiments conducted to determine the fundamentals of heat and mass transport in parboiled rough rice kernels exposed to MW energy determined that parboiled rough rice soaked at 76°C then steamed for 10 min had a MC immediately after parboiling of 35.88%. This MC reduced to a FMC of 13.48% after being treated with power level of 2 kW and drying duration of 31.5 min (MW specific energy of 3780 kJ.[kg-grain]⁻¹) and at a low specific power of 2.92 kW.[kg-DM]⁻¹. The drying rate was highest during the beginning of drying then slowed down during the end and can be divided into 2 periods, an initial falling rate period (1.5 min to 7.5 min), and the second falling rate period (7.5 min to 31.5 min). Of the Page, Newton, Logarithmic, and Henderson & Pabis semi-empirical drying models, the logarithmic model best represented the MW drying behavior of parboiled rough rice kernels as determined by having the highest $R^2 = 99.99 \times 10^{-2}$ and Adjusted $R^2 = 99.99 \times 10^{-2}$ and lowest Reduced $\chi^2 = 1.88 \times 10^{-2}$ and $RMSE = 0.06 \times 10^{-2}$. The drying constant (k) was determined to be 0.05 h⁻¹. The effective moisture diffusivity (D_{eff}) was determined to be 5.04×10^{-11} m².s⁻¹. The activation energy (E_a) was determined to be 3.02 kW.kg⁻¹.

1.

Parboiled rough rice surface temperature had statistically significant increases as a result of increasing drying duration at a power level of 2 kW. The rough rice surface temperature immediately after parboiling was determined to be 54.73 °C. During microwave drying, as the drying duration increased, so did the parboiled rough rice surface temperature increase to a final surface temperature of 92.61 °C at a power level of 2 kW and drying duration of 31.5 mins (MW specific energy of 3780 kJ.[kg-grain]⁻¹) and at a low specific power of 2.92 kW.[kg-DM]⁻¹. The energy consumption of the MW drying process was determined to be 1.05 kWh.[kg-grain]⁻¹. The drying efficiency of the MW drying process was determined to be 18.89%. The cost to dry a ton of high MC parboiled rough rice was \$88.31 at a commercial energy rate of 8.41 cents per kWh in the state of Arkansas (2020). There was a statistically significant reduction in MRY and HRY as a result of increasing MW drying duration. Control samples dried gently using natural-air had MRY and HRY of 70.14% and 67.86%, respectively. The MRY and HRY associated with the one pass drying at specific energy of 3780 kJ.[kg-grain]-were 65.01% and 59.98%, respectively.

These findings suggest that MW drying of parboiled rough rice followed by tempering could be optimized to remove significant amounts of moisture from high MC parboiled rough rice in one pass. However, there is an opportunity to refine the MW drying process to improve efficiency and to reduce the cost.