



ELSEVIER

Available online at www.sciencedirect.com

ScienceDirect

Procedia - Social and Behavioral Sciences 111 (2014) 1004 – 1014

Procedia
Social and Behavioral Sciences

EWGT2013 – 16th Meeting of the EURO Working Group on Transportation

Route planning for electric buses: a case study in Oporto

Deborah Perrotta^{a,b}, José Luís Macedo^a, Rosaldo J. F. Rossetti^{a,*}, Jorge Freire de Sousa^c, Zafeiris Kokkinogenis^a, Bernardo Ribeiro^d, João L. Afonso^b^aLIACC, DEI, Faculdade de Engenharia, Universidade do Porto, Portugal^bCentro Algoritmi, Universidade do Minho, Portugal^cUGEI, INESC TEC, Faculdade de Engenharia, Universidade do Porto, Portugal^dCentro para a Excelência e Inovação na Indústria do Automóvel (CEIIA), Portugal

Abstract

This paper intends to analyze the performance of an electric bus for three different routes in the city of Oporto. The objective is to study the correlation between the type of route a bus travels and the amount of energy it spends in performing it. Besides energy, the potential of the recovering part of it through regenerative braking will also be discussed. It is expected that long and demanding routes, e.g. those encompassing meandering paths, will make the bus use more energy. To accomplish these objectives, a simulation platform was built upon both a nanoscopic representation of the electrical bus and its microscopic interaction with the road traffic network while performing different journeys through specific routes. Simulation results are compared and discussed, as well as are directions for future work identified.

© 2013 The Authors. Published by Elsevier Ltd.

Selection and/or peer-review under responsibility of Scientific Committee

Keywords: Electric Bus Performance; Mathematical Modeling; Route Planning; Simulation Platform.

1. Introduction

The transportation domain has gained significance in the context of climate change and energy savings. It is largely responsible for the high increase in greenhouse gases emissions over the past two decades, with an increase of 11.4% between 1990 and 2010. This definitely does not follow the tendency in the energy sector (under which it is categorized) that on the other hand, decreased in the same period of time (Nations, 2012).

Electric vehicles seem to play an important role on the solution of this matter, once it is characterized for having zero tailpipe gas emissions. Moreover, one can say that public transportation is a crucial part of the

* Corresponding author. Tel.: +351-22-508-1566; Fax: +351-22-557-4103.
E-mail address: rossetti@fe.up.pt

solution to a country's economic, energy, and environmental challenges, contributing to bring a better quality of life. A correct implementation reduces emissions, provides affordable options to personal mobility alternative to driving, downgrades household and congestion costs. In many cases, higher density urban development would be more difficult without the existence of public transportation because more land would need to be devoted to parking and travel lanes (Federal Transit Administration (FTA), 2010).

By the conjugation of both possible parts of the solution presented above, one can come to electric public transportation, and in order to be more effective in the sense of making people leaving their cars at home, electric buses. Buses, generally speaking, are characterized for promoting a door-to-door service, which cannot be achieved by the deployment of transportation solution such as trolleys, subways or trains. Nevertheless, planning routes for buses that would satisfy a higher amount of citizens is a very complex issue.

Usually, on a bus transportation company of a large city, the routes that the buses will perform on a certain day are assigned with the aid of a decision support system, taking into account various factors including, for instance, the maintenance state of each bus, its type (standard, articulated, double deck) and other characteristics (low floor, wheelchair access, etc.). The bus can perform the same route all day long or make different ones, either intercalated with long stops at the depot out of peak hours or working continuously.

In the specific case of electric buses, it is very important to take some other factors into consideration. One of these is the total energy of the batteries (or another energy storage device) that can be provided for the buses. Another crucial factor is the topography profile of each route, which has a huge influence on its performance and autonomy.

There is a lack of evidence in the literature reporting on tools and methods to precisely evaluate the performance of electric buses in urban settings. Tools that would allow for the correct representation of the routes to be performed, possessing elements such as bus stops, traffic lights, interactions with other vehicles and topography of the field are not available as easily. In addition, a tool that would also calculate some performance measures from the vehicles' point of view, such as the required energy to perform the route and the potential of recovering energy on braking episodes is also of paramount importance.

This paper intends to analyze the energetic profile of an electric bus performing three routes with specific characteristics, namely: urban route, inter-urban route and a tortuous route. This is accomplished by the use of an integrated simulation platform, following the High-Level Architecture (HLA) approach for distributed simulation. This platform accounts for the microscopic traffic simulator SUMO (Simulation of Urban MObility) which was coupled with a model of an electric bus powertrain designed in the *Matlab/Simulink* environment.

The structure of this paper is as follows: Section 2 describes all components of the integrated simulation framework; Section 3 defines the methodological approach and the simulation test-bed; Section 4 stresses some accomplished results and discussion; Section 5 states some related work and Section 6 draws some conclusions.

2. Integrated Simulation Platform

2.1. Traffic simulation - SUMO environment

SUMO (Behrisch, Bieker, Erdmann, & Krajzewicz, 2011) is a suite of applications that are used to design and implement realistic traffic domain simulations. Its underlying simulation model represents both the road network infrastructure and the traffic demand, and has become an important and popular tool within the urban traffic and transportation community. In fact SUMO has been used in several research studies such as route choice (Doering, Pögel, & Wolf, 2010), traffic light algorithm (J. Macedo, Soares, Timóteo, & Rossetti, 2012) and the simulation of vehicular communications (Lan & Chou, 2008), among others.

As SUMO follows the microscopic modeling approach, its resolution level considers a detailed representation of the traffic dynamics. This approach will describe the behavior of entities that make up the traffic stream as well

as their interactions. In microscopic models, the level of detail scales down the individual behavior of vehicles, their interaction with each other and with the road network up to the single junction level.

To define the entity “vehicle”, the modeler needs to associate it with an identifier (name), a departure time and provide it a route through the network. If it is necessary a vehicle can be further described with more details. A simulated vehicle can be assigned a type that describes the vehicle’s physical properties and the variables of the kinematic model. A pollutant or noise emission model can be associated with each vehicle rendering the simulation more realistic. The origin/destination pairs, such as the lane to use, the speed, or the position can also be defined. By distinguishing different vehicle types, SUMO also allows the simulation of public transport or emergency vehicle prioritization at intersections.

The simulation is time-discrete having a default simulation step length of 1s and it is space-continuous. Internally, a lane and the distance from the beginning of it describe each vehicle’s position. When moving through the network, each vehicle’s speed is computed using a car-following model.

As the traffic simulation SUMO requires the representation of road networks and traffic demand to simulate in an own format, both have to be imported or generated using different sources. Regarding the network, there are different ways of creating road networks in SUMO. Thus networks can be either built using the application “netgen” or generated by importing a digital road map. The road network importer “netconvert” allows the conversion of other formats (VISUM, Vissim, or MATsim, shapefiles or Open Street Maps) to SUMO.

With respect to the traffic demand, there are some applications implemented within SUMO suite that allows the generation of traffic flow over the networks. *Jtrrouter* is a route computation application that uses definitions of turn percentages at intersection for computing routes through the network. Such an approach can be used to set up the demand within a part of a city’s road network consisting of up to ten nodes. Another application is the *dfrouter* that computes routes by using information from loop detectors. This approach is quite successful when applied to highway scenarios where the road network does not contain rings and the highway entries and exits are completely covered by detectors (Behrisch et al., 2011).

The definitions of vehicles can be generated using different sources. For large-scale scenarios usually so-called “origin/destination matrices” (O/D matrices) are used. They describe the movement between traffic assignment zones in vehicle number per time. SUMO deals with the O/D matrices using the “od2trips”; it is an application for converting O/D matrices to single vehicle trips. Besides disaggregating the matrix, the application also assigns an edge from the road network as depart/arrival position. The map from traffic assignment zones into edges is to be given to application as one input (Behrisch et al., 2011).

SUMO supports the extensibility to its core and control through TraCI (Traffic Control Interface) (Behrisch et al., 2011). TraCI is an API for SUMO that allows the traffic simulation to interact with an external application via a socket connection in run-time. This approach allows the application to retrieve values of simulated objects and to manipulate their behavior. TraCI has an extensive documentation of the methods for communication with SUMO. It is composed by three main sets of functions that are related to the information access, to the states of change and to the subscription of determined structure’s variables.

2.2. Powertrain simulation - Simulink/ Matlab environment

A mathematical model has been devised and implemented to account for the necessary calculations to be performed as means to analyze an electric bus performance. This performance can be characterized by different parameters, such as torque, power, energy, efficiency, among others. Basically, what this model does is to calculate the required tractive force to perform a certain route. This tractive force accounts for the amount of effort needed to be made in order to overcome all the forces that prevents the movement of the vehicle. Those forces are mainly dependent on the speed of the bus and the intrinsic characteristics of the route, which is designed on the traffic simulator SUMO. All mathematical equations of this sub-section were defined on a previous paper of the main author (Perrotta, Teixeira, Silva, & Ribeiro, 2012).

After the definition of all the equations involved on the mathematical model, this was further applied and implemented on *Simulink*, part of the *Matlab* environment, as it can be observed in Fig.1.

Simulink is a block diagram environment for multi-domain simulation and Model-Based Design. It supports system-level design, simulation, automatic code generation, and continuous test and verification of embedded systems. *Simulink* provides a graphical editor, customizable block libraries, and solvers for modeling and simulating dynamic systems. It is integrated with *Matlab*, enabling the incorporation of *Matlab* algorithms into models and export simulation results to *Matlab* for further analysis (“*Simulink - Simulation and Model-Based Design*,” n.d.).

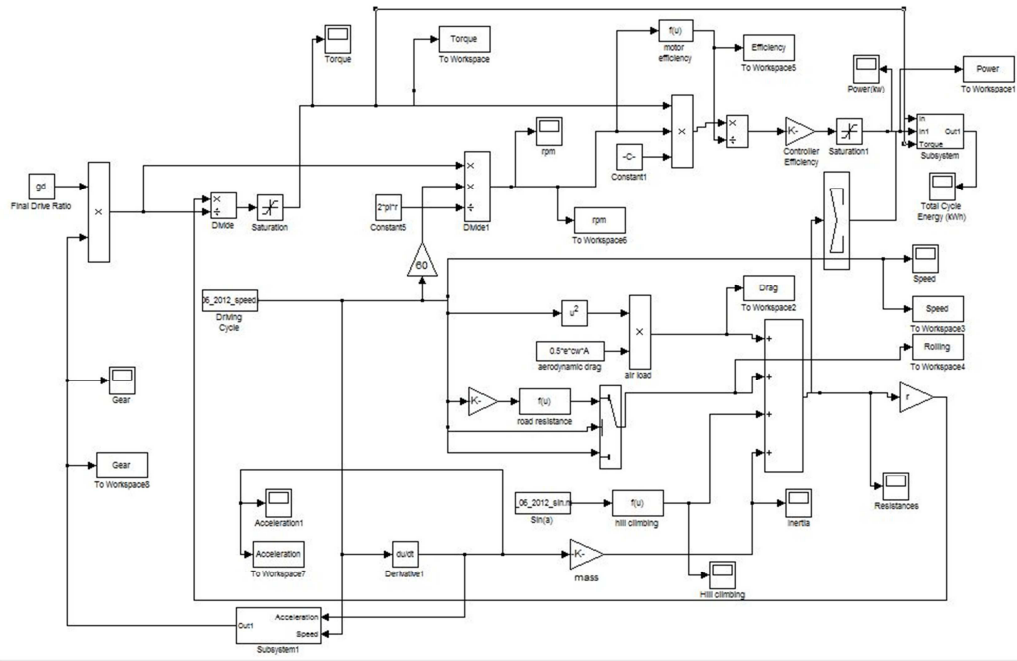

Fig.1. Electric bus simulation model on Simulink

In the next sub-sections, key quantities of the model will be discussed.

- Tractive Force

This is the force propelling the vehicle forward, transmitted to the wheels. This force must overcome the vehicle resistance to the movement, which is composed by the sum of the different forces that act against its movement. This tractive effort has to accomplish the following (Ehsani, Rahman, & Toliyat, 1997; Larminie & Lowry, 2003):

- To overcome the rolling resistance;
- To overcome the aerodynamic drag;
- To provide the force needed to overcome the component of the vehicle's weight acting down the slope;
- To accelerate the vehicle, if the velocity is not constant.

The rolling resistance force is primarily due to the friction of the vehicle tire on the road. The aerodynamic force is due to the friction of the vehicle body moving against the air. The hill climbing force is the force needed to drive the vehicle up a slope. The acceleration force provides the linear acceleration of the vehicle.

- Torque, Power and Motor Speed

The next step is to calculate torque, which is expressed by the multiplication of the radius of the tire by the tractive effort delivered by the powertrain divided by the gear ratio of the transmission system connecting the motor to the axle.

The power in each step of the simulation is calculated as a function of the vehicle torque and motor speed. At this point, the efficiencies of the motor and the controller are considered. Moreover, the motor speed in revolutions per minute can be calculated taking into account the linear speed, the perimeter of the wheel and the transmission gear ratio.

- Kinetic Energy

The effect of the vehicle mass when accelerating and stopping in town and city conditions is a field where the mass of the electric vehicle will have considerable influence on vehicle performance. When the vehicle brakes, the kinetic energy is converted into heat at the braking disks. When regenerative braking is used, a certain amount of the energy is recovered. This model calculates the amount of kinetic energy that it's dissipated in braking, considering the tires and air resistance and the climbing grade, which can contribute positively or negatively to the regenerative braking.

2.3. High-level architecture approach

The High Level Architecture (HLA) IEEE standardized architecture addresses the reuse and interoperation of legacy model simulations. The HLA concept is based on the idea of the distributed simulation approach that no single simulation model can satisfy the requirements of all usages and users.

A simulation model or set of simulations designed for one purpose can be applied to another application under the HLA federation's concept: a comprised set of interacting simulations. The intent of the HLA is to provide modelers a flexible framework that will support the reuse and the interoperation of their existing simulation models (and the capabilities of them) in different simulation systems or contexts. The selected definition of architecture as intended in HLA—"major functional elements, interfaces, and design rules, pertaining as feasible to all simulation applications, and providing a common framework within which specific system architectures can be defined" (Society, 2000).

The HLA concept finds a wide applicability through a vast range of simulation application areas such as education, training, analysis, engineering and even entertainment at multiple levels of resolution. These broadly different application areas suggest the variety of requirements that have been taken into account for the development and the ongoing evolution of the HLA standards.

Three main components formally define the HLA concept (Society, 2000):

- The HLA Framework and Rules Specification, summarizes a set of rules that ensure the proper interaction of federates in a federation and define the responsibilities of federates and federations;
- The Object Model Template (OMT), provides the object models that define the information produced or required by a simulation application and for matching definitions among simulations to produce a common data model for mutual interoperation;
- The Federate Interface Specification describes a generic communications interface that allows simulation models to be connected and coordinated, implemented by RTI that will be required for runtime operation.

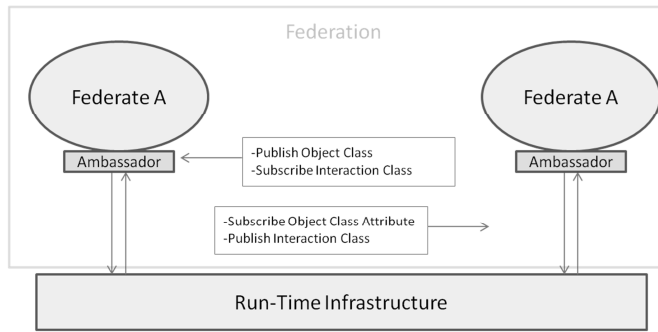

Fig. 2. HLA System Architecture

An HLA ecosystem is divided in its major functional elements, as follows.

The first key elements are the simulation resources called federates. A federate can be a computer simulation, an interface to a live system or a support utility such as an event logger or performance monitor. The HLA imposes no constraints on what is represented in a federate or how it is represented, but it does require that all federate incorporate specified capabilities to allow the objects in the simulation to interact with objects in other simulations. These specifications are included into the federation object model (FOM).

The second functional element is the runtime infrastructure (RTI). The RTI is a distributed operating system for the HLA ecosystem. The RTI will provide a set of general-purpose services that support federate-to-federate interactions and the overall management and support functions.

The third element is the interface to the RTI. The HLA runtime interface specification provides a standard way for federates to interact with the RTI, to invoke the RTI services to support runtime interactions among federates and to respond to requests from the RTI.

The HLA ecosystem defined as above takes the name of HLA federation (Fig. 2) that is a named set of federate applications and a common federation object model (FOM) that are used as a whole to achieve some specific objective. A federation execution is the actual operation, over time, of a set of joined federates that are interconnected by a RTI.

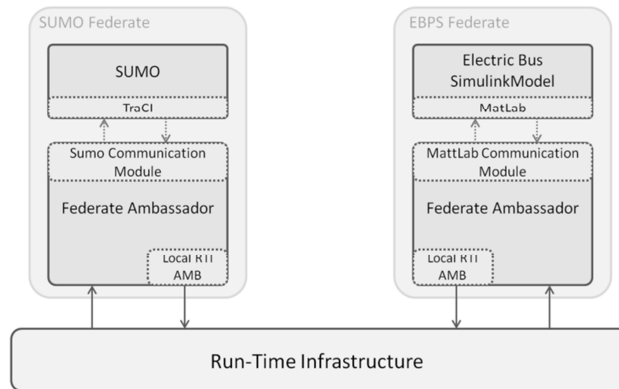

Fig. 3. HLA Implementation Architecture (J. L. P. Macedo, 2013)

3. Methodological Approach

3.1. Detailed framework

In order to overcome the lack of appropriate tools to evaluate the performance of electric vehicles on urban environment, accounting for the detailed representation of the routes they would perform, this paper makes use of an integrated simulation platform as it has been presented in (J. L. P. Macedo, 2013) and is currently under an improvement process phase.

The integrated platform accounts for the representation of two different systems. On the one hand, there is the traffic system, which is the road network (expressing the physical infrastructure and the topology) and the vehicle-entities that move on it. On the other hand, the electric bus system is defined in terms of its powertrain subsystem such as the set of battery and traction motor, among others. To address the issues of the traffic system, a microscopic modeling approach is required (J. L. P. Macedo, 2013).

The integration among them is achieved by associating the electric bus powertrain subsystem to a vehicle entity (corresponding to a vehicle of class “bus”) of the microscopic traffic model. Thus, important criteria for the selection of the simulators (implementing the microscopic and nanoscopic models) are the ease of access to the respective model variables, the application programming interfaces (API) and communication protocols (J. L. P. Macedo, 2013). In order to implement the physical road infrastructure and the traffic dynamics through vehicular movements in microscopic level resolution, the SUMO software suite has been considered. And for the simulation of electric bus operations and performance, a mathematical model of an electric bus implemented in *Simulink* has been considered (Perrotta et al., 2012). Fig. 3 illustrates the main federate components and interactions.

3.2. Simulation set-up

As already mentioned, three routes are analyzed in this paper in what concerns primarily the required energy to be completed and the potential of recovering part of it in braking episodes. In order to define the routes, data was collected and further made available to the authors directly from the Portuguese urban transportation company STCP (*Sociedade de Transportes Colectivos do Porto – Oporto Society of Public Transports*) (STCP, 2011). This data accounts for all the geographic coordinates of bus stops for each of the three routes. These coordinates were of great use for the definition of the bus route on SUMO. It was assumed that the bus would stop in every bus stop and would stay there for 20 seconds, which is the average time provided by STCP. The speed profile of the bus is defined by the technical characteristics of the motor and the maximum speed, by the regulation. It is important to state that an ideal traffic flow was considered, which means that the buses performed on free-flow roads.

Regarding the routes, each of them has some specific characteristics, as it can be observed in Table 1.

Table 1. Routes characteristics

| Bus lines | Type | Stops (n°) | Size (km) |
|-----------|----------------------|------------|-----------|
| 401 | Demanding topography | 26 | 8 |
| 204 | Urban | 38 | 12 |
| 602 | Inter-urban | 55 | 19 |

Line 401 is characterized for having a demanding topography to be performed. It is small urban route composed by many elevations and curves. Line 204 is a regular urban route, though more linear than line 401. Line 602 is an inter-urban route, longer than the others and accounting for bigger distances between stops and less traffic lights in some parts of the route.

The data used hereafter is taken from an existent electric bus, currently under its testing phase in Portugal. The bus model is EL2500, manufactured by the Portuguese company *CaetanoBus* (CaetanoBus, 2011). This electric bus uses a brushless permanent magnetic electric motor, with 650 N.m peak torque and 150 kW peak power. Motor efficiency data was extracted from the supplier's plot of motor efficiency versus motor speed and a mathematical equation was deduced from it. Table 2 shows the necessary parameters used to perform the simulations:

Table 2. Variables definition

| Parameter | Value |
|------------------------------|-----------------------|
| Tire Radius | 0.5 m |
| Road Surface Coefficient | 1.2 |
| Vehicle Frontal Area | 10 m ² |
| Gravitational Acceleration | 9.8 m/s ² |
| Aerodynamic Drag Coefficient | 1.17 |
| Air Density | 1.2 kg/m ³ |
| Vehicle Mass | 17,048 kg |
| Controller Efficiency | 92% |
| Gear Ratio | First Gear: 1:3 |
| | Second Gear: 1:1 |
| | Differential: 8.83 |

4. Experimental results and discussion

Simulations were performed for the analysis of the three routes mentioned before. Some of the collected data included speed, acceleration, energy and braking resistance energy, which accounted for the energy that is wasted on braking episodes by the vehicle. The higher this waste, the lower it can be recovered by the engine in its regenerative-braking mode and the smaller the efficiency.

One parameter that makes sense to be analyzed is the amount of energy spent per kilometer, once the routes are really different among them. Line 204 was the one that spent the least amount of energy per kilometer performed, thus being used to normalize the parameter, being the other two bus lines compared on a percentage purpose, as it can be observed in Fig. 4(a).

Line 204 is an urban route composed of many linear parts. Line 602 is an inter-urban route, and it spent 11% more energy per kilometer when compared to line 204. By analyzing this pair, it is clear that the amount of energy spent is quite similar; from one side, there is a route with linear parts, which allows for the maintenance of a constant speed for larger periods of time while on the other side, there is a long route with bigger distances between bus stops, which implies the same benefits from line 204.

Nevertheless, line 401 spent 31% more energy to be performed per kilometer. This route is characterized for being quite short, having then fewer bus stops. However, the topography is quite demanding, being composed by many curves and the bus stops are closer to each other, demanding more energy from the bus to perform more accelerations on smaller periods of time.

The next analyzed parameter is the amount of energy the vehicle wastes while braking in what concerns the forces that act against its movement, namely rolling resistance, aerodynamic drag, inertia and elevations per kilometer. It is relevant to say that the analysis does not take into account elevations, once the simulation platform does not yet supports this parameter. Moreover, similarly to the previous case, line 204 was the one with less energy wasted in braking episodes (being again the one to be compared to), and it can also be justified by the more linear route it accounts for. Also maintaining the tendency, line 602 follows line 204, wasting only 9%

more energy than line 204 per kilometre. In addition, the most demanding route, line 401, led the bus to waste 23% more energy per kilometre, as it can be observed in Fig. 4(b).

At this point, it is relevant to say that the efficiency of the bus would not necessarily be related to the last analysed parameter. Taking line 401 as an example, its demanding route made it requires either more energy per kilometre and waste more energy per kilometre on resistance forces than the other two. However, in order to have an accurate analysis, one would have to analyse the amount of recovered energy on those same braking episodes, which is a non-analysed parameter for this paper. Thus it would play an important role when calculating the efficiency of the vehicle for this route.

The last investigated parameter was the amount of energy wasted on braking episodes on resistance forces to the movement in comparison to the amount of energy required to complete the whole route. Surprisingly, all routes wasted around 12% of this total energy on those resistance forces.

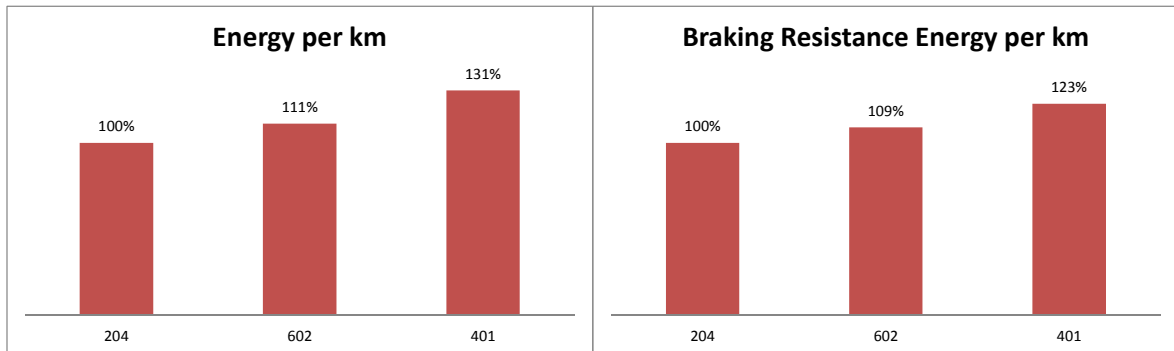

Fig. 4. (a) Comparative analysis on the energy spent (b) energy wasted on braking episodes per kilometre (normalized by line 204)

5. Related work

For this paper, related work would comprise other works that suggest a similar approach to overcome the problem statement herein presented. Recapitulating, the problem is how to simulate an electric vehicle performance on urban environment, accounting for the realistic representation of the route.

Maia et. al (2011) propose a simulation framework for electric vehicles in terms of energy consumption, providing a means for conducting studies of electric mobility in urban areas. It is composed basically by two components: one that extends the traffic simulator SUMO in a 3D simulation environment and one that represents an electric vehicle, which was coupled to the car-following model they proposed (Maia, Silva, Ara, & Nunes, 2011). It seems that the platform is all built upon modules added to SUMO and it does not integrate different simulators as the solution proposed in this paper.

Lei (2011), on the other hand, propose an integrated platform to simulate the wireless communication between vehicles. SUMO and Simulink are both part of this integrated platform, being SUMO responsible for the mobility behavior of a “vehicle” whose traffic mobility-related parameters were supplied by its controller provided by the Simulink model. Moreover, the integration between SUMO and *Simulink* is accomplished by converting the model implemented in Simulink to C++, once SUMO is C++-based (Lei, 2011).

Both references propose integrated platforms to solve a certain problem; the first one has a similar problem statement but the platform proposed by the authors does not integrate different simulators, whereas the second one has a different problem statement but integrates two simulators in a different manner. Thus, the integrated

simulation platform herein proposed has a huge potential, especially in what concerns interoperability and the reuse of legacy software.

6. Conclusion

It could be concluded that the most demanding route in what concerns shorter distances between bus stops and many sinuous segments was also the route that demanded more from the bus, according to the analyzed parameters. It spent more energy per kilometer to perform the route and wasted more energy on the braking resistance forces. The urban route had the best performance by having the lower values for all the parameters analyzed. Moreover, it is relevant to say that efficiency analysis would require more data, especially regarding the amount of energy recovered in the regenerative braking. Elevations would also affect the required energy for the bus to perform those routes, and due to restrictions of the simulation platform, they were not considered in this paper.

Future work comprises the inclusion of a third axis in the simulation platform to account for elevations. In addition, more data collection is required, and more parameters must be analyzed, such as regenerative braking energy and efficiency. This would allow for a more complete performance analysis and it would possibly play an important role on the route planning of public transport operations based on electric buses.

Acknowledgements

This work is financed by FEDER Funds, through the Operational Programme for Competitiveness Factors – COMPETE, and by Portuguese Funds through FCT (Fundação para a Ciência e Tecnologia), under Project 13844. FCT is also acknowledged by its financial support through PhD scholarship grants SFRH/BD/67202/2009 and SFRH/BD/51256/2010, the latter within the MIT-Portugal Program in Engineering Design and Advanced Manufacturing – Leaders for Technical Industries focus area.

References

- Behrisch, M., Bieker, L., Erdmann, J., & Krajzewicz, D. (2011). SUMO – Simulation of Urban MObility. *SIMUL 2011: The Third International Conference on Advances in System Simulation* (pp. 63–68).
- CaetanoBus. (2011). CaetanoBus. Retrieved March 28, 2011, from <http://www.caetanobus.pt/>
- Doering, M., Pögel, T., & Wolf, L. (2010). DTN Routing in Urban Public Transport Systems. *CHANTS '10 Proceedings of the 5th ACM workshop on Challenged networks* (pp. 55–62).
- Ehsani, M., Rahman, K. M., & Toliyat, H. a. (1997). Propulsion system design of electric and hybrid vehicles. *IEEE Transactions on Industrial Electronics*, 44(1), 19–27. doi:10.1109/41.557495
- Federal Transit Administration (FTA). (2010). *Public Transportation 's Role in Responding to Climate Change. Energy*.
- Lan, K., & Chou, C. (2008). Realistic Mobility Models for Vehicular Ad hoc Network (VANET) Simulations. *8th International Conference on ITS Telecommunications, 2008. ITST 2008* (pp. 362–366).
- Larminie, J., & Lowry, J. (2003). *Electric Vehicle Technology Explained. Electric Vehicle Technology Explained* (p. 62; 183–186). John Wiley & Sons Ltd.
- Lei, C. (2011). *Cooperative Adaptive Cruise Control model study based on traffic & network simulation*. MSc Thesis, Faculty of Electrical Engineering, Mathematics and Computer Science, University of Twente.
- Macedo, J. L. P. (2013). *An Integrated Framework for Multi-Paradigm Traffic Simulation*. MSc Thesis, Faculty of Engineering, University of Porto.
- Macedo, J., Soares, M., Timóteo, I., & Rossetti, R. J. F. (2012). An Approach to Advisory-Based Traffic Control. *2012 7th Iberian Conference on Information Systems and Technologies (CISTI)* (pp. 1–6).
- Maia, R., Silva, M., Ara, R., & Nunes, U. (2011). Electric Vehicle Simulator for Energy Consumption Studies in Electric Mobility Systems. *2011 IEEE Forum on Integrated and Sustainable Transportation Systems* (pp. 227–232). Vienna.
- Nations, U. (2012). *Framework Convention on Climate Change*.

Perrotta, D., Teixeira, A., Silva, H., & Ribeiro, B. (2012). Electrical Bus Performance Modeling for Urban Environments. *SAE 2012 World Congress*. doi:10.4271/2012-01-0200

Simulink - Simulation and Model-Based Design. (n.d.). Retrieved April 30, 2013, from <http://www.mathworks.com/products/simulink/>

Society, I. C. IEEE Standard for Modeling and Simulation (M & S) High Level Architecture (HLA) — Framework and (2000).

STCP. (2011). STCP - Sociedade de Transportes Colectivos do Porto, SA. Retrieved September 25, 2011, from <http://www.stcp.pt>