



International Workshop on Healthcare Open Data, Intelligence and Interoperability (HODII)
November 2-5, 2020, Madeira, Portugal

Adaptive Business Intelligence: A New Architectural Approach

João Lopes*, Tiago Guimarães, Manuel Filipe Santos

University of Minho, Centro ALGORITMI, Braga, Portugal

Abstract

Healthcare systems face enormous challenges, fundamentally due to the amount of data generated daily in a hospital environment, which forces entities to reflect on how to organize and use the same data. Currently, the number of studies at this level is growing, focusing on the innovation to be implemented, so that this same sector can adopt new methodologies, architectures and technologies that allow a more efficient support of existing hospital processes, as well as the results to be provided to all professionals involved in this area. In this research, an Adaptive Business Intelligence architecture is proposed, whose contribution was supported by the realization of an adequate conceptual and technological framework describing its development at different levels. Thus, a possible modernization of several working methods is initiated, with the introduction of an architecture capable of contributing to several factors, both at clinical and administrative levels, meeting the needs of a hospital system, regarding the design, development, implementation and demonstration of results.

© 2020 The Authors. Published by Elsevier B.V.

This is an open access article under the CC BY-NC-ND license (<http://creativecommons.org/licenses/by-nc-nd/4.0/>)

Peer-review under responsibility of the Conference Program Chairs.

Keywords: Adaptive Business Intelligence; Healthcare; Architecture;

1. Introduction

As medical organizations modernize their operations, data logging is becoming increasingly important due to the integration of information systems capable of creating, collecting and managing all information, both at medical and administrative levels [9]. The result is an unprecedented growth in the volume of data, largely due to the

* Corresponding author. Tel.: +351934373667;

E-mail address: lopesit@outlook.pt

computerization of the current society, which thanks to the rapid development of tools for the collection, storage and visualization of data, seeks to facilitate not only in the performance of tasks, but also in communication between different health units. All this leads them to be agile and need to make quick strategic and operational decisions, some of which are complex. Making such decisions may require considerable amounts of relevant data and information, and it is essential to obtain knowledge through them [5].

The integration of intelligent systems in the area of Health is something widely discussed, not only because of the capacity to support the data that are generated on a daily basis, but also because of the expectation to insert the evolution of an intelligent system in the improvement of the care provided to the community, without discarding the capacity to assist administrators in the management of strategic decisions and the positive contribution that it can have in the functioning of the same organization [1].

The application of an Adaptive Business Intelligent system in Healthcare is thus recognized as an important step in the modernization that is expected in this sector, but also a challenge, due to the complexity of implementing a technological architecture that is sufficiently efficient in the performance of its different modules. Healthcare covers a long process of diagnosis, treatment and prevention of disease, as well as other physical and mental disabilities, generating a huge amount of data, including medical records, administrative reports and results for future benchmarking [6]. All this opens up opportunities to discover new and valuable information from this large volume of data, from a set of Data Mining techniques and tools properly prepared for this purpose, able to help and diagnose your clinical and administrative decisions. However, it is also important to mention that the usefulness of this process depends largely on existing data and that, in most situations, access to the same complete health records is extremely challenging [1]. This is a process that is widely recognized in all health organizations, and which needs to be taken into account due to its importance, placing itself as an important obstacle, so that the application of the most varied stages of development of an Adaptive Business Intelligent system are not questioned.

2. Adaptive Business Intelligence: A New Trend

The concept of adaptability appears in the most diverse markets, of which it already presents real applications, both in the automotive market and even in search engines. Over the years, large amounts of data have been stored by the administrators of any organization, in the belief that it contains some valuable information. However, it is perceptible that the real value of these data depends exclusively on the analysis capacity of the same organization. It is in this perspective that the need arises to frame these same systems in the area of health, with the capacity to recover, treat and interpret them, so that users can obtain new knowledge, which before would not have it, in the form of tables and graphs, for a better observation and understanding of the results obtained. In general, the needs detected in the area of Healthcare projects the development of systems capable of [8]:

1. Enable access to data from different sources;
2. Transform data into information;
3. Forecasting models developed based on Data Mining results;
4. Optimization models in full integration with the forecasting models mentioned above, in order to enable the search for new and improved solutions;
5. An adaptability module, integrated in the optimization models, responsible for the adaptation of the results to the contextualization of the problem;
6. Visualization of the knowledge acquired through the above mentioned architecture;

An Adaptive Business Intelligent system is the term to be used when you want to combine, in one system, predictive levels for the identification of possible future scenarios, as well as an optimization base, which looks for even more framed scenarios with those that were predicted, according to the existing restrictions in each problem. In this way, the system will always be prepared to answer two fundamental questions:

1. What is likely to happen in the future?

2. What is the best decision at that moment?

In this process, and according to Figure 1, it is possible to identify the structural components of an Adaptive Business Intelligence system [8]:

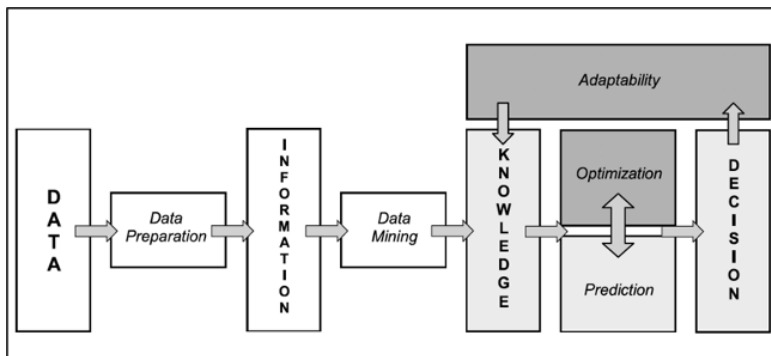

Figure 1 - Architecture of an Adaptive Business Intelligence System.
Withdrawn from (Michalewicz, 2006)

The representation of this system is essentially organized in three main structures: A first level, duly focused on a set of essential operations aimed at standardizing and processing data for use in future operations. A second and a third level, which are articulated simultaneously, of Forecasting and Optimization, which aim to offer a set of decisions adapted to the context in which the same organization operates, offering knowledge that it previously did not have. Thus, while a Business Intelligent system is widely defined as a set of technologies capable of storing, organizing and analyzing data, the term Adaptive Business Intelligent represents evolution, in something that can be seen as a system capable of using advanced forecasting and optimization techniques, in order to enhance intelligence in strategic decisions. This is, therefore, a new approach, a new evolution of this same system, now able to recommend future decisions, based on already existing data from the past of the organization, contributing to the increase of productivity, efficiency and competitiveness of the same [7].

3. Adaptability in Idealized Approach: A Docker Approach

In line with the themes already introduced, it is necessary to identify the components that could be integrated, at the level of architecture required, in this research. In this way, in order to achieve an ideal modelling for this type of themes, the concept of Docker is introduced, a platform that executes applications and makes the process easier to develop and distribute.

The introduction of this technology aims to provide the user, in addition to greater ease of provision of the tools needed for the applicability of intelligent models, a service previously prepared to connect to the necessary data sources and, fundamentally, a platform prepared to apply the models in an easier way. As can be seen in figure 2, the applications that are built in the Docker are integrated in Docker Containers, these same with the ability to be permanently active, in an isolated way, at the top of the kernel of the operating system, providing a fast and light environment where the code can be executed efficiently [2].

The integration of Docker in the architecture of an Adaptive Business Intelligent system comes from the advantages that this same platform can offer, according to the theme in which it can be introduced [2]:

1. Speed, due to the short space occupied by each Docker Container;

2. Scalability, due to the possibility of being installed in several servers, being also relatively simple in the adjustments that may be necessary to make throughout the implementation and development of the system;
3. Density, since the Docker uses the available resources in a more efficient way, allowing more containers to be run on a single host;

The presentation of this architecture requires, initially, the explanation of the reasons that lead to the integration of certain technologies in this environment, so that it can justify some existing concerns. At the base of it is the use of the Docker software, which will allow the operationalization of several processes in only one environment, allowing the integration of any necessary application and its operation independently from any other existing configuration. In the existing reasons for the choice of this same software stand out [2] [3]:

1. The virtualization process of an application, making the Docker Containers lighter compared to the standard version of an application, managing and running them in the environment where they are inserted;
2. The isolation of virtualized applications in Docker Containers, allowing them to be executed by their images. A Docker Image is similar to an Ubuntu base image, allowing users to make changes to a Docker Container, the Docker adds an additional layer containing the changes to the image, not making any change to its base image. This process makes the image distribution process more efficient, since it only updates the one that is necessary for its distribution;

Being this architecture framed with a set of works to be performed in the future, we can state that the solution presented for this same research fits the requirements it aims to solve, in the sense that this same architecture can integrate future modeling, according to the existing problems and projects of each user, in different hospital units. Thus, this is an architecture that aims to eliminate both the difficulties of access to integrations for an intelligent system, as well as possible problems related to the processing of various algorithms, especially if we focus on large amounts of data, a reality increasingly present in a healthcare system.

4. Integration of Intelligent Models

The development of the architecture components developed so far show the full availability of all the software needed to model intelligent systems, for predictive purposes, as well as for optimization processes, as well as the necessary links to obtain the necessary data. However, although these executions can be performed, there is a need to have something that can automate the same processes, removing an operational layer from the user in obtaining results, as well as opening new perspectives of monitoring and control of the running processes.

To automate certain processes, was developed an API Rest, with relationships between three distinct areas:

1. Firstly, the Script Repository, which represents a greater focus since it has the responsibility to produce new results as well as to design the final implementations. This repository uses exclusively all the content that can be produced by the technologies already mentioned, RStudio and Jupyter Notebook. Thus, users who produce encoding in any possible language, R or Python, should be responsible for ensuring an implementation oriented to the direct insertion of the intended results with the data sources used in the same project. Once these same scripts are fully encoded, the user will place it as available in a local folder, properly created in the system, which will serve as a repository for reading and supporting the API.
2. A second area, which represents only the developed Rest API, that occupies a central role in the Adaptive Business Intelligent system developed, since it ensures a continuous connection between existing data and the intelligent modeling inserted in the repository;

3. Finally, the reference to the data source, which besides having the data for use in Machine Learning projects, plays a role of control and monitoring of the executions of the scripts already mentioned.

Finally, the use of this same operational layer is considered beneficial, not only because it facilitates the achievement of results, but also automates some control and implementation operations. It should be noted that the implementation of these same technologies were only decisions that allowed a greater ease of integration into the system already developed, not creating restrictions or constraints to the principles of the Adaptive Business Intelligent architecture developed.

Figure 4 helps to explain the logic mentioned in the previous paragraphs.

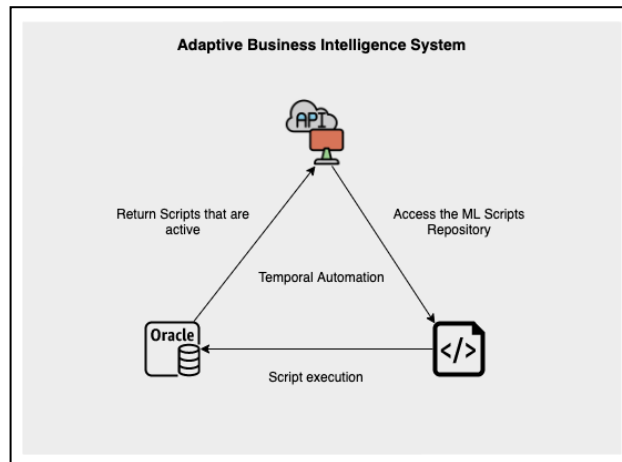

Figure 2 - Functioning of the API Rest

5. Conclusions

The development of this research project had as main purpose the development of an Adaptive Business Intelligent Architecture, which could support a set of data related to Healthcare areas, with predictive techniques, including later a set of optimization models, in order to obtain a system that could obtain adaptability to current circumstances, reflecting past and current behaviors, as well as advising a set of future measures, with a view to the proper functioning of the same organization. The results are conclusive, taking into account a set of established objectives:

1. Availability of Adaptive Business Intelligent Architecture, enabling the creation of services and technologies fully prepared and integrated with the basic technologies of a hospital system, obtaining greater accessibility and availability of them;
2. Detailed specification of the different levels of the same architecture, explaining the importance and advantages associated to each one;
3. Introduction of different optimization models in order to obtain better results, articulating the differences of each model with the importance of each one in the codification developed
4. The planning of an Adaptive Business Intelligent Architecture with integration of a Rest API, opening new possibilities for an increasingly independent, robust and intelligent system;

Given the possibility of introducing new services in the architecture, it is anticipated the capacity to go further, with regard to the technologies inserted. Thus, it is possible to mention that the final result of this Project offers an innovative architecture, whose inserted technologies allow adopting and integrate future projects, with a clear

contribution to the area of Data Science and Adaptive Business Intelligent systems, framed in a clinical and organizational aspect of a Healthcare Entity.

After the conclusion of this investigation, it is still possible to mention some perspectives, regarding future works, projecting real implementations of projects in this same architecture, developing a set of Prediction and Optimization Models for some Healthcare entities. The integration of the Rest API in this same architecture opens new possibilities in the management of the information introduced in the different systems, for control and monitoring of the same services. Idealizing new scenarios for the development and expansion of this same architecture, it is foreseen the development of a web platform for a better visualization of the results associated with the aforementioned projects, as well as articulating the different APIs developed in a platform that contributes to the monitoring of the different data automation services.

Acknowledgements

The work has been supported by FCT – Fundação para a Ciência e Tecnologia within the Project Scope: UID/CEC/00319/2020.

References

- [1] Ashfaq, A. &. (2019). Machine learning in healthcare -- a system's perspective. ArXiv, abs/1909.07370.
- [2] Bashari Rad, B., Bhatti, H., & Ahmadi, M. (2017). An Introduction to Docker and Analysis of its Performance. *IJCSNS International Journal of Computer Science and Network Security*, (pp. 10.3233/IDA-2007-11602).
- [3] Boettiger, C. (2015). An introduction to Docker for reproducible research. *Operating Systems Review (ACM)*.
- [4] Bui, T. (2015). Analysis of Docker Security. ArXiv.
- [5] Han, J. a. (2012). *Data Mining: Concepts and Techniques*. Morgan Kaufmann.
- [6] Jothi, N., Rashid, N. A., & Husain, W. (2015). Data Mining in Healthcare - A Review. *Procedia Computer Science*, (p. 10.1016/j.procs.2015.12.145).
- [7] Lopes, J., Guimarães, T., & Santos, M. F. (2020). Predictive and Prescriptive Analytics in Healthcare: A Survey. *The 3rd International Conference on Emerging Data and Industry 4.0 (EDI40)*, 10.1016/j.procs.2020.03.078.
- [8] Michalewicz, Z. a. (2006). *Adaptive Business Intelligence*. Springer.
- [9] Ramesh, S., Delen, D., & Turban, E. (2014). *Business intelligence and analytics: Systems for Decision Support*. Pearson.