

# The Characterization of joint Behaviour in Mortarless Refractory Masonry

Rafael Oliveira<sup>1\*</sup>, João Rodrigues<sup>1</sup> and João Pereira<sup>2</sup>  
University of Coimbra<sup>1</sup>; University of Minho<sup>2</sup>

## Abstract

The understanding of the compressive and tangential behaviour of mortarless joints is mandatory to optimize the design of refractory linings. The joints play an important role during the heating of the equipment, as they reduce the stresses generated due to thermal expansion. This study investigates the normal and tangential behaviour of joints in alumina spinel bricks. The mechanical characterization of the compressive strength of the material is performed at room and elevated temperature. During fabrication this brick, it is pressed, therefore, tests were performed in pressing and orthogonal-to-pressing direction. The thickness of joints is estimated based on a compressive test in two stacked bricks, the joint closure is a nonlinear and strongly heterogeneous and nonlinear phenomena. The determination of the friction angle and friction coefficient of the bricks were performed based on a slipping test.

## 1. Introduction

Industrial equipment, such as steel ladles and furnaces, are protected against the liquid they contain by a refractory lining. During the heating, the mismatch between the coefficients of thermal expansion of the steel shell and the refractory lining leads to significant stresses at the lining, therefore the joints play an important role, as they reduce the stresses during heating<sup>1</sup>.

Finite element models are used to predict the behaviour of refractory linings in service. However, due to the excessive numbers of bricks and interfaces in industrial furnaces, some homogenization techniques shall be applied to reduce the computational resources required to run the simulations, allowing the engineers to run more models and option the design of the linings. Some techniques of homogenization are available on literature, nevertheless, the behaviour of the homogenized material shall be determined experimentally<sup>2,3,4</sup>.

The aim of this study is to investigate the normal and tangential behaviour of mortarless masonry. The compressive strength of the material was determined for room and elevated temperature. The joint closure behaviour was analyzed based on compressive tests on two stacked bricks at room temperature<sup>5</sup>. The friction coefficient between the bricks were determined on slipping tests.

## 2. Experimental Procedure

The masonry studied is mortarless refractory masonry. Given to the traditional usage of alumina spinel bricks in steel ladles, it was decided to use these products for the experimental characterization. The basic unit is the brick, therefore the first task of the investigation plan is to characterize it to understand its thermomechanical behaviour.

### 2.1 Compressive Strength at Room Temperature

The thermomechanical characterization of the brick comprises compressive tests at room and elevated temperatures on cylindrical samples extracted from the bricks. In these tests, a specimen of known dimensions is subjected to an increasing compressive load until its failure, when it cannot withstand a further increase in load. The crushing strength is calculated from the maximum load divided by the cross-section area. Three series of tests were performed, as presented in **Fig. 1**:

- Series 1:  $\varnothing 50 \times 120$  mm samples extracted from the edged, brick in the direction of pressing;
- Series 2:  $\varnothing 50 \times 100$  mm samples extracted from the rectangular brick, in the direction of pressing;
- Series 3:  $\varnothing 50 \times 50$  mm samples extracted from the rectangular brick, in the direction orthogonal to the direction of pressing.

The tests were performed under strain control, at the rate of 0.01%/s.

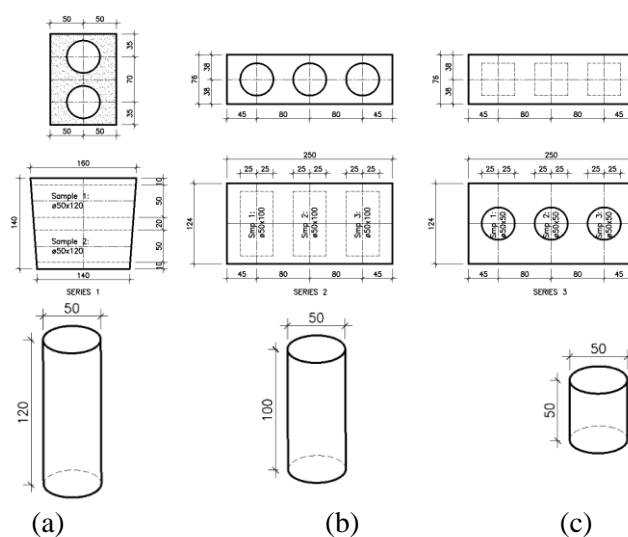
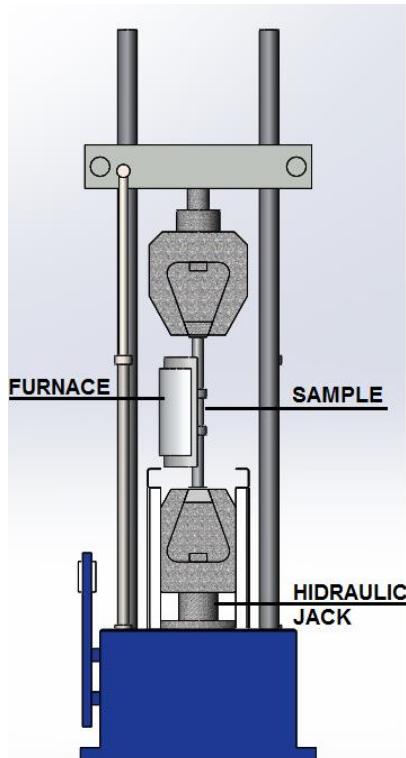

**Fig. 1** Samples dimensions: (a) Series 1; (b) Series 2 and 4; (c) Serie 3

## 2.2 Compressive Strength at Elevated Temperature

The series 4 tests were performed at elevated temperatures, in air atmosphere and under a heating rate of 5 °C / min. The heating rate was chosen based on experiments performed by other researchers<sup>(6),(7),(8),(9)</sup>. To guarantee the thermal equilibrium, one test were performed with three thermocouples installed inside the sample for each temperature, moreover a dwell time of one hour was used.

The samples were testes at 600 °C, 800°C and 1.000°C. The experimental setup is presented in **Fig. 2**.

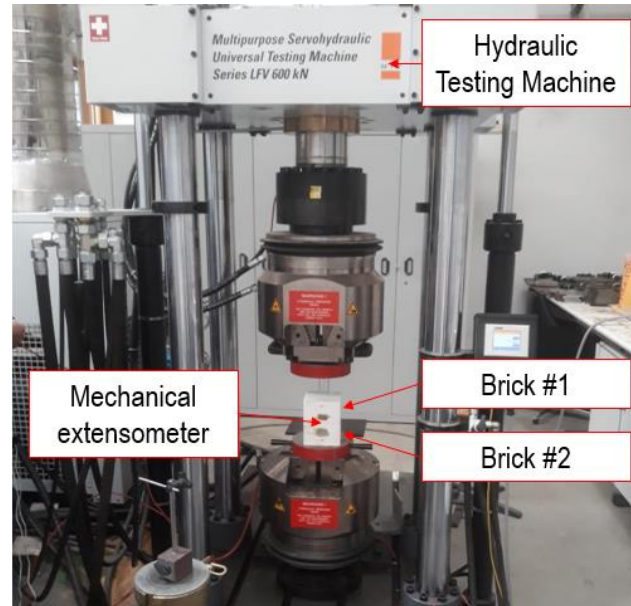

**Fig. 2 Test setup for thermomechanical characterization of the bricks**

## 2.3 Joint Closure Test

The joint closure test was performed in two stacked bricks at atmospheric conditions and room temperature. A Multipurpose Servo hydraulic Universal Testing Machine Series LFV 600 kN with a load was used, as shown in **Fig. 3**. The compression tests were performed at a constant load control of 0.1 kN/s, up to 150 kN, the increasing of load was stopped when the brick behaviour was obtained. The cycles of load were applied. The strains were measured by a mechanical strain gauge positioned at the mid-height of the bricks assembly.

Based on the test result, it was possible to determine the thickness of the joint and the behaviour of the joint closure.

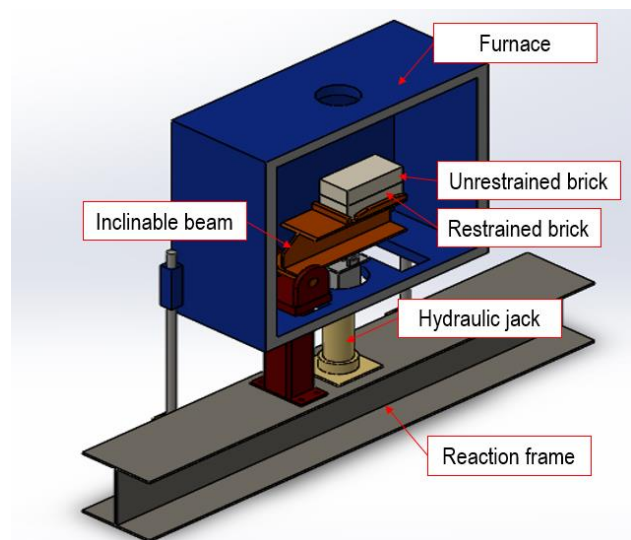

**Fig. 3 Joint closure test: Experimental setup**

## 2.4 Friction Coefficient Test

The friction angle ( $\phi$ ) and the friction coefficient ( $\mu$ ) were determined based on an slipping test. In this test, two bricks are stacked and positioned in an inclinable beam, the brick in the bottom is constrained and the upper brick is allowable to move. The hydraulic jack is used to increase the inclination of the beam until the slipping of the brick, as shown in **Fig. 4**. The upper brick will slip as soon as the friction angle is reached. The friction coefficient may be obtained by the tangent of the friction angle, as presented in equation 1.

$$\mu = \tan(\phi) \quad (1)$$



**Fig. 4 Slipping test: Experimental setup**

### 3. Results and discussion

This section presents the experimental results and discussion regarding them.

#### 3.1 Compressive Strength

The compressive strength at room and elevated temperature is presented in Table 1 and Table 2, respectively.

**Table 1 Compressive strength at room temperature: Series 01, 02 and 03**

Serie	Direction	Sample	fc [MPa]	fc avg [MPa]	Std Dev [MPa]
S01	Pressing direction	S1.01	34.4	29.2	3.2
		S1.02	29.4		
		S1.03	26.2		
		S1.04	26.8		
S02	Pressing direction	S02.01	35.6	32.43	3.65
		S02.02	34.4		
		S02.03	27.3		
S03	Orthogonal to pressing direction	S03.01	27.5	27.43	0.16
		S03.02	27.6		
		S.03.03	27.2		

**Table 2 Compressive strength at elevated temperature: Series 04**

Serie	Sample	Temp. [°C]	fc [MPa]	fc avg [MPa]	Std Dev [MPa]
S04	600.TC	600	25.9	24.21	2.38
	600.01	600	25.9		
	600.02	600	20.8		
	800.TC	800	35.8	34.35	1.69
	800.01	800	35.3		
	800.02	800	32.0		
	1000.TC	1000	24.2	27.00	4.08
	1000.01	1000	32.8		
	1000.02	1000	24.1		

Based on the tests results, it was observed that:

- The edged brick (S02) presents a compressive load slightly smaller than rectangular brick (S01).
- The compressive strength in the pressing direction (S02) is bigger than the

compressive strength in the direction orthogonal to pressing direction (S03).

- Regarding the elevated temperature tests, it is possible to identify a reduction in the compressive strength at 600°C, that may be caused by cracking during heating. At 800°C, there is an increase in the resistance, possible due to crack restoration in elevated temperatures. At 1000°C, it is possible to identify a reduction in the compressive strength.

**Fig. 5** presented the changes in compressive strength within temperatures increase.

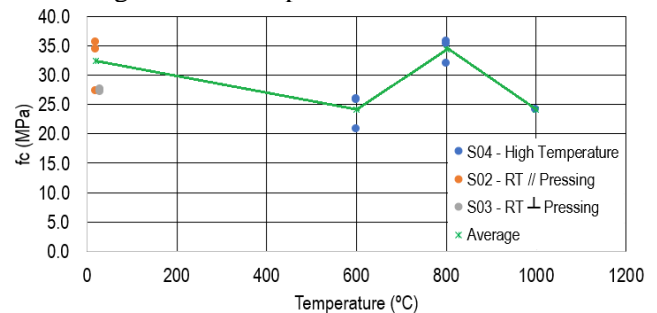

**Fig. 5 Material degradation within temperature**

#### 3.2 Joint Closure Test

The joint thickness plays an important role, once it reduces the compressive stress generate at the lining due to thermal expansion. **Fig. 6** presents the joint closure curve. Based on the experimental results, it was possible to identify the joint thickness.

Three load cycles were applied to the bricks. At the first cycle, it is possible to identify a more heterogeneous behaviour, the initial joint thickness was 0.21 mm, which is in good agreement to the values usually used for designing steel ladles, 0.20 mm.

For the second and third load cycles, a more homogeneous behaviour was observed, the joint thickness reduces to 0.09 mm. This reduction may be caused by the crushing of non-flat initial surfaces on the bricks.

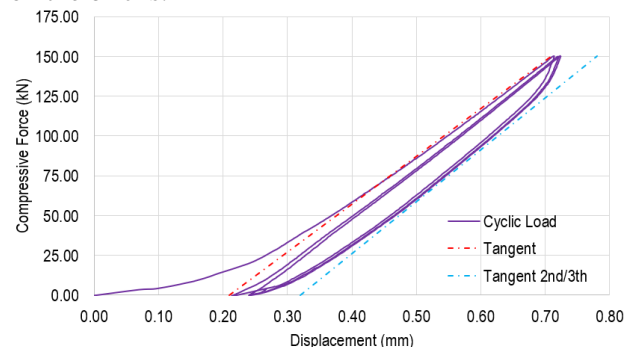

**Fig. 6 Joint closure test Material degradation within temperature**

### 3.3 Friction Coefficient

Three tests were performed for the slipping test, at room temperature. Based on the slipping tests, it was found that the average friction angle between the bricks was 26.7 degrees. Therefore, the friction coefficient was calculated as  $\mu = 0.507$ .

### 3.4 Perspectives and Future Tests

Aiming to improve the understanding of dry joints on refractory masonry, the following tests will be performed in future researches:

- Joint closure tests with Digital Image Correlation (D.I.C.) aid in alumina spinel bricks: this non-contact full field measurement technique may be used to measure local and global variations and help to better understand the joint closure behaviour<sup>5)</sup>.
- Triplet shear tests in alumina spinel bricks: the triplet shear test is usually used to characterize the tangential behaviour masonry. This test will be performed and the results will be compared to the ones obtained by slipping test.
- Slipping tests at elevated temperature: an experimental layout is being developed to measure the friction angle between bricks in elevated temperatures. Therefore, it will be possible to analyse the evolution of the friction angle within temperature for refractory masonry.
- Evaluate the friction coefficient between the work lining and safety lining.

### 4 Conclusions

Refractory masonry is widely used in high temperature industrial devices to protect the metallic parts against the elevated temperatures.

The joint thickness plays an important role, once it reduces the compressive stress generated at the lining due to thermal expansion. A study on the tangential behaviour of refractory mortarless joints was presented.

Compressive tests were performed in cylindrical samples extracted from the bricks, aiming to determine the compressive strength of the material at room and elevated temperature.

To determine the normal behaviour of the joint, compression tests were performed in two stacked bricks at room temperature. The joint thickness was determined for the first load cycle and to the following cycles. As concluded by other authors<sup>1), 5)</sup>, the joint closure behaviour is strongly heterogeneous and nonlinear.

### Acknowledgments

This work was supported by the funding scheme of the European Commission, Marie Skłodowska-Curie Actions Innovative Training Networks in the frame of the project ATHOR - Advanced Thermo-mechanical multiscale modelling of Refractory linings 764987 Grant.

### References

- 1) A. Gasser, K. Terny-Rebeyrotte, and P. Boisse, "Modelling of joint effects on refractory lining behaviour," *Proc. Inst. Mech. Eng. Part L J. Mater. Des. Appl.*, vol. **218**, no. 1, pp. 19–28, 2004.
- 2) T. M. H. Nguyen, E. Blond, A. Gasser, and T. Prietl, "Mechanical homogenisation of masonry wall without mortar," *Eur. J. Mech. A/Solids*, vol. **28**, no. 3, pp. 535–544, 2009.
- 3) K. Andreev, S. Sinnema, A. Rekik, S. Allaoui, E. Blond, and A. Gasser, "Compressive behaviour of dry joints in refractory ceramic masonry," *Constr. Build. Mater.*, vol. **34**, pp. 402–408, 2012.
- 4) K. I. Gasser, A.; Blond, E.; Daniel, J. L.; Andreev, "Influence of different masonry designs of refractory bottom linings," **9th Int. Mason. Conf.**, pp. 1–10, 2014.
- 5) S. Allaoui, A. Rekik, A. Gasser, E. Blond, and K. Andreev, "Digital Image Correlation measurements of mortarless joint closure in refractory masonries," *Constr. Build. Mater.*, vol. **162**, pp. 334–344, 2018.
- 6) R. Ceylantekin and C. Aksel, "The comparison of mechanical behavior of MgO-MgAl<sub>2</sub>O<sub>4</sub> with MgO-ZrO<sub>2</sub> and MgO-MgAl<sub>2</sub>O<sub>4</sub>-ZrSiO<sub>4</sub> composite refractories," *Ceram. Int.*, vol. **38**, no. 2, pp. 1409–1416, 2012.
- 7) M. Nath and H. S. Tripathi, "Thermo-mechanical behavior of Al<sub>2</sub>O<sub>3</sub>-Cr<sub>2</sub>O<sub>3</sub> refractories: Effect of TiO<sub>2</sub>," *Ceram. Int.*, vol. **41**, no. 2, pp. 3109–3115, 2015.
- 8) S. Mukhopadhyay, K. Dana, S. Moitra, S. Basumallick, and T. K. Mukhopadhyay, "Thermal and thermo-mechanical characteristics of monolithic refractory composite matrix containing surface-modified graphite," *Ceram. Int.*, vol. **42**, no. 5, pp. 6015–6024, 2016.
- 9) L. Musante, L. F. Martorello, P. G. Galliano, A. L. Cavalieri, and A. G. Tomba Martinez, "Mechanical behaviour of MgO-C refractory bricks evaluated by stress-strain curves," *Ceram. Int.*, vol. **38**, no. 5, pp. 4035–4047, 2012.