



**UNIVERSITY OF  
KWAZULU-NATAL**

---

**INYUVESI  
YAKWAZULU-NATALI**

**An investigation into marine bacterial species found in shark mouths in the  
Indian Ocean and their implications for human health**

By

**Yathisha Ramlakhan**

*B.Sc. B. Med Sc (Hons) (UKZN)*

**Submitted in fulfilment of the requirements for the degree of M. Med. Sci**

**in the**

**Discipline of Medical Biochemistry and Chemical Pathology**

**School of Laboratory Medicine and Medical Sciences**

**College of Health Sciences**

**University of KwaZulu-Natal**

**Durban**

**2015**

## Abstract

There is an ever increasing amount of pollution and waste being released into the environment. This is due to the increase in population, urbanisation and people migrating into cities. Approximately 2.4 billion people living in urban and rural areas have no access to basic sanitation. In the next 20 years, there will be a further increase of 2 billion people who will lack basic sanitation. In developing countries, 90% of untreated sewage is released into rivers, lakes and coastal waters. Apart from sewage, waste such as petroleum products, heavy metals and organochlorine also contribute to marine pollution. Companies that manufacture sugar/artificial sweeteners etc. and farming activities that utilize fertilizers for crops can cause eutrophication, as un-used fertilizers get washed into rivers. The marine water is a different environment to other aquatic and terrestrial environments. This then forces microbes to adapt, so they can be able to survive in the marine environment. The difference in the marine environment allows for the production of distinct bioactive metabolites such as secondary metabolites. These secondary metabolites come from algae and marine bacteria and these secondary metabolites are then exclusive to the marine waters. These secondary metabolites can be used for medical purposes, cosmetics, personal-care products etc. There is a huge problem with antibiotic resistance and research needs to be done to solve this resistance issue.

Two common bacterial strains were isolated and identified from the mouth of sharks. The bacteria were identified as *Bacillus cereus* and *Vibrio alginolyticus*. They were isolated and cultured in broth for 3 days, till they reached the log phase of growth. The broth was then extracted for metabolites which the bacteria produced, using ethyl acetate. These metabolites

were tested for cytotoxicity in the human liver hepatocellular carcinoma (Hep G2) cells. The concentrations that were determined to cause 50% cell death (IC<sub>50</sub>) in the cell viability assay on Hep G2 cells were 0.764 mg/ml and 0.918 mg/ml for *B. cereus* and *V. alginolyticus*, respectively. These values were then used for subsequent assays.

Antibacterial testing was done for the bacterial extracts of *Bacillus cereus* and *Vibrio alginolyticus*. There was no antibacterial activity against *Escherichia coli* ATCC 25922, *Staphylococcus aureus* ATCC 25923 and *Pseudomonas aeruginosa* ATCC 27853. Assays that used flow cytometry was used to show if apoptosis/necrosis occurred. These were assays such as Annexin V and propidium staining. While assays that used luminometry showed the levels of ATP and determined whether apoptosis of the cells occurred. These were assays such as the ATP assay, mitochondrial depolarisation assay and determination of the caspase activities of caspase 3/7, 8 and 9. Additional assays, like the comet and TBARS assays, were done to show DNA fragmentation and oxidative stress of the cells, respectively. The results for the Annexin V/ propidium staining showed the control had a mean of  $11.20 \pm 1.0$ . Extract 1 ( $20.83 \pm 0.8737$ ) and extract 2 ( $25.37 \pm 1.050$ ) showed a higher percentage when compared to the control. Extract 2 was significant against the control ( $p < 0.0273$ ). For propidium staining, the control had a mean of  $6.033 \pm 0.4524$ . Extracts 1 ( $11.57 \pm 1.387$ ) and 2 ( $11.43 \pm 0.3215$ ) showed a higher percentage when compared to the control. The Annexin V and propidium staining suggested that extract 1 and 2 had undergone both apoptosis and necrosis. For luminometry assays, the ATP assay showed that the control had a mean of  $1.83 \times 10^6 \pm 5.82 \times 10^4$ . Extracts 1 ( $1.5 \times 10^6 \pm 9.4 \times 10^4$ ) and extract 2 ( $1.4 \times 10^6 \pm 8.3 \times 10^4$ ) showed a decrease in ATP with reference to the control. In the mitochondrial depolarisation assay, the control had a mean of  $14.83 \pm 1.350$ . Extracts 1 ( $30.57 \pm$

0.75) and extract 2 ( $20.53 \pm 8.56$ ) showed a decrease in polarisation with reference to the control. For caspase 8 analysis, the control, extract 1 and extract 2 had means that were  $4.23 \times 10^4 \pm 3.37 \times 10^3$ ,  $52 \times 10^3 \pm 10.1 \times 10^3$  and  $40 \times 10^3 \pm 5.2 \times 10^3$ , respectively. For caspase 9 analysis, the control, extract 1 and extract 2 had means that were  $8.6 \times 10^4 \pm 4.6 \times 10^3$ ,  $5.6 \times 10^4 \pm 4 \times 10^3$  and  $9.6 \times 10^4 \pm 5.6 \times 10^4$ , respectively. The caspase 3/7 analysis showed that the control, extract 1 and extract 2 had means of  $4.4 \times 10^3 \pm 0.57 \times 10^3$ ,  $5.5 \times 10^3 \pm 0.19 \times 10^3$  and  $5.8 \times 10^3 \pm 2 \times 10^3$ , respectively. Caspase 3/7 showed that apoptosis had occurred with the cells for all extracts used. Extract 1 showed a high caspase activity for caspase 8. This suggested that it followed the extrinsic pathway of apoptosis. Extracts 2 showed a high activity for caspase 9 which suggested that it followed the intrinsic pathway of apoptosis. The comet assay showed that the means of the control, extract 1 and extract 2 were  $35.91 \pm 21.93$ ,  $75.85 \pm 11.43$  and  $60.48 \pm 11.86$ , respectively. The extracts were significantly higher than the control (extract 1 and 2  $p < 0.0001$ ). Extract 1 and 2 were compared to each other and had shown a significance between them ( $p < 0.0001$ ). The TBARS assay obtained the following MDA concentrations for the control, extract 1, extracts 2, negative and positive samples: 0,137, 0,132, 0,150, 0,088 and 20,502, respectively. The MDA concentration gives an indication of oxidative stress of the cells.

From the cell viability assay, the secondary metabolites produced by *B. cereus* needed a lower concentration of extract to determine an  $IC_{50}$  value. This suggested that the secondary metabolites produced by *B. cereus* were more toxic than the secondary metabolites produced by *V. alginolyticus*. This was then further supported by assays such as mitochondrial depolarisation and the comet assay. The secondary metabolites that could be the reason why there were apoptosis and necrosis, are the toxins the bacteria produce. This is the enterotoxin or cereulide

produced by *B. cereus* and TLH by *V. alginolyticus*. However, further studies need to be done to confirm if these toxins are the cause of cell death.

## DECLARATION

This study represents the original work by the author and has not been submitted in any form to another university. The use of work by others has been duly acknowledged in the text.

The research described in this study was carried out in the Discipline of Medical Biochemistry (Faculty of Health Sciences) and Biomedical Resource Unit (BRU) University of KwaZulu-Natal, Durban, under the supervision of Professor A.A. Chuturgoon, Dr. Alisa Phulukdaree, Dr. Linda Bester and Dr. Sanil Singh.

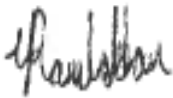

.....  
Yathisha Ramlakhan



.....  
Professor A. A Chuturgoon

## **ACKNOWLEDGEMENTS**

### **My family**

I thank my parents, Rajend Ramlakhan and Ishara Ramlakhan, for being the reason I have come this far in my life. For all the motivation, advice, sacrifices and the investments made towards me and my future. I thank my brother, Yashveer Ramlakhan, for his support, advice and sacrifices he has made for my future. To my Uncle, RadhaKrishna Bhola, for all the support, advice and sacrifices he has made. Sadly my Dad and Uncle are no longer with us. I hope that Dad, you are watching over me and will guide me through my life. I hope that you are proud of me and know that You are the reason that I am the person I am today and I have come this far because of You and Mum. To my Uncle who has always been ever willing to help in my studies. I thank you all.

### **Professor A. A Chuturgoon**

I thank you for allowing me to become a part of the Medical Biochemistry Department. I also thank you for the support, advice, guidance, motivation, patience and knowledge that you have given me. Prof, you truly are the backbone of Medical Biochemistry. I am forever grateful for the opportunities that you have given me.

### **Dr. Alisa Phulukdaree**

I thank you for all the guidance, advice, motivation, help and all the knowledge that I have gained during this year. You are not only the person I have learnt so much from but you have also become my friend. I appreciate the patience that you have shown toward me and the willingness to assist me with my project.

### **Dr Linda Bester and Dr. Sanil Singh**

I thank the both of you for allowing me to work at your labs at BRU and helping and guiding me with the microbiology work. To Dr. Bester, I thank you for your motivation, support, knowledge and assistance in the lab. My microbiology work became much simpler with your guidance.

### **The master and PhD students of Medical Biochemistry 2013**

I would like to thank Miss Charlette Tiloke, Miss Prithiksha Ramkaran, Miss Savania Nagiah, Miss Vanessa Korb, Miss Meghan Harvey, Miss Samantha Anderson, Miss Shivona Gounden, Miss Nasreen Khan and Mr Sibonelo Ngcoya for all the assistance in the lab, advice, guidance and the many questions I have asked. I am appreciative of the patience and ever-willing attitude to help and make the research project as simple as possible. I thank you for the knowledge that you have passed on to me. I also appreciate all the friendships that already existed and the new ones that were made. Apart from the work that needed to be done, we also enjoyed a more jovial side.



Staff of Medical Biochemistry and Biomedical Research Unit

I thank Mrs Narisha Needhi, Mrs Rene Myburg and Mrs Ritta Raddebe for all the consumables needed, administrative help as well as advice and support towards my project and future.

**To all of you, I thank you. To my family especially, I THANK YOU.**

### **Funding**

- 1) The financial assistance of the National Research Foundation (NRF) towards this research is hereby acknowledged. Opinions expressed and conclusions arrived at, are those of the author and are not necessarily to be attributed to the NRF.
- 2) I also have received a scholarship from the College of Health Science and would like to acknowledge the financial assistance they provided.

## List of Abbreviations

$\Delta\Psi_m$	mitochondria trans-membrane potential
$\Delta\Psi$	membrane potential
ATP	Adenosine triphosphate
ADP	Adenosine diphosphate
<i>B. cereus</i>	<i>Bacillus cereus</i>
bp	base pair
CCM	complete culture media
CO <sub>2</sub>	carbon dioxide
Cyt K	cytotoxin K
DMSO	Dimethyl sulfoxide
DNA	deoxyribonucleic acid
dNTP	deoxyribonucleotide triphosphate
<i>E. coli</i>	<i>Escherichia coli</i>
EMEM	Eagle's minimal essential medium
ER	endoplasmic reticulum
ETC	electron transport chain

FITC	fluorescence isothiocyanate
GSPx	glutathione peroxidase
H <sub>2</sub> O <sub>2</sub>	hydrogen peroxide
H <sub>3</sub> PO <sub>4</sub>	phosphoric acid
HCL	hydrochloric acid
HIV	human immunodeficiency virus
Hbl	haemolysin B1
h	hours
IC <sub>50</sub>	50% inhibitory concentration
JC-1	5',6,6'-tetrachloro-1,1',3,3'-tetra-ethylbenzimidazole carbayanine iodide
kb	kilobase
KZN	KwaZulu Natal
LC <sub>50</sub>	50% lethal concentration
LMPA	low melting point agarose
m	mitochondrial
MDA	malondialdehyde
min	minute

MMP	mitochondrial membrane permeabilization
MnSOD	manganese superoxide dismutase
MOMP	mitochondrial outer membrane permeabilisation
mtNOS	nitric oxide synthase
MTT	3-[4,5- dimethylthiazol-2-yl]-2,5 diphenyl tetrazolium
NaCl	sodium chloride
NADH	nicotinamide adenine dinucleotide
NEDD	N-(1-naphthyl)-ethylenediamine
Nhe	nonhaemolytic enterotoxin
NO	Nitric oxide
NOS	nitric oxide synthases
nm	nanometer
$O_2^-$	superoxide
OD	optical density
$OH^\bullet$	hydroxyl radical
OH	hydroxide
$ONOO^-$	peroxynitrite

PCR	polymerase chain reaction
PBS	phosphate buffer saline
pH	potassium hydrogen
PI	propidium iodide
Pi	inorganic phosphate
PS	phosphatidylserine
RLU	relative light units
rpm	revolutions per minute
RNA	ribonucleic acid
ROS	reactive oxygen species
sec	second
STD	sexually transmitted disease
SULF	sulphanilamide
TB	tuberculosis
TBA	2-thiobarbituric acid
TBA/BHT	2-thiobarbituric acid/butylated hydroxytoluene
TBARS	thiobarbituric acid reactive substances

<i>trh</i>	thermostable direct-like haemolysin
μl	microliters
UN	United Nations
UV	ultraviolet light
V	volts
VCL <sub>3</sub>	vanadium (III) chloride
WHO	World Health Organisation

#### **Reference strains used for antibacterial testing**

- 1) *Staphylococcus aureus* ATCC 25923,
- 2) *Escherichia coli* ATCC 25922
- 3) *Pseudomonas aeruginosa* ATCC 27853

## List of Figures and their Description

### Chapter 1

- ❖ Figure 1: An illustration of the Indian Ocean boundary (Wafar et al., 2011) .
- ❖ Figure 2: The Marine Diversity that exists in the Ocean (Nybakken and Webster, 1998).
- ❖ Figure 3: A dead shark with its fins cut off lying on the ocean floor (Verlecar et al., 2007).
- ❖ Figure 4: Cost of sharks' fin is determined from which part of the body the fin comes from (Verlecar et al., 2007).
- ❖ Figure 5: a) Sharks that were finned b) Shark fins c) Sharks fins laid out to dry (Verlecar et al., 2007).
- ❖ Figure 6: A shark-fin soup delicacy (Verlecar et al., 2007).
- ❖ Figure 7: A schematic representation of the factors that contribute to the water pollution in Kwa-Zulu Natal which come from effluents from treatment plants (Mema, 2010).
- ❖ Figure 8: The pollution in Durban Harbour (Mema, 2010).
- ❖ Figure 9: The 4 sampling sites along the Umhlathuze River. The number 1 represents Felixton Bridge; 2 represents Kwa-Dlangezwa; 3 represents Mzingazi and 4 represents UMhlathuze (Mthembu et al., 2012).
- ❖ Figure 10: A flow diagram depicting the outcomes of when fish come into contact with a toxicant (Adapted from (Austin, 1999)).
- ❖ Figure 11: Cells representing carcinogenic and normal cells. a) Human Embryonic Kidney Cells (HEK293T cells) b) Human Coronary Artery Endothelial Cells (HCAEC cells) (Soria-Mercado et al., 2012).

## Chapter 2

- ❖ Figure 12: An example of clinical isolates causing zones of inhibition when tested against *E. coli* using the zone of inhibition method (Pabba et al., 2011).
- ❖ Figure 13: A diagram illustrating the movement of ions in electrophoresis (Dennison, 2002).
- ❖ Figure 14: An illustration depicting the process of ATP assay using the CellTiter-Glo® Assay Reagent (Source: Promega CellTiter-Glo® Luminescent Cell Viability Assay, Technical Bulletin No. 288).
- ❖ Figure 15: The electron transport chain and membrane potential across the mitochondria (Christensen et al., 2013).
- ❖ Figure 16: The various stages of apoptosis observed using Jurkat cells that were treated with anti-Fas and was incubated with V-Oregon Green and PI (Vermees et al., 2000).
- ❖ Figure 17: Caspase 3/7 cleaves the luminogenic substrate that comprises of DEVD. Amino-luciferin is then liberated to cause the luciferase reaction and emit light (A) (Source: Promega Caspase-Glo® 3/7 Assay, Technical Bulletin). Caspase 8 cleaves the luminogenic substrate that comprises of LETD. Amino-luciferin is then liberated to cause the luciferase reaction and emit light (B) (Source: Promega Caspase-Glo® 8 Assay, Technical Bulletin). Caspase 9 cleaves the luminogenic substrate that comprises of LEHD. Amino-luciferin is then liberated to cause the luciferase reaction and emit light (C) (Source: Promega Caspase-Glo® 9 Assay, Technical Bulletin).
- ❖ Figure 18: Illustrations depicting the process of Caspase-Glo 3/7 and Caspase-Glo 8 assays using the Caspase- Glo® 3/7 Reagent and Caspase- Glo® 8 Reagent respectively



(Promega Caspase-Glo® 3/7 Assay, Technical Bulletin, Promega Caspase-Glo® 8 Assay, Technical Bulletin).

- ❖ Figure 19: An illustration depicting the process of Caspase-Glo 9 assay using the Caspase- Glo® 9 Reagent (Promega Caspase-Glo® 9 Assay, Technical Bulletin).

### Chapter 3

- ❖ Figure 20: Testing of the crude extracts from *B. cereus* against *Staphylococcus aureus* ATCC 25923 using the zone of inhibition method to determine if the extracts had any antibacterial activity (Pictures supplied by author).
- ❖ Figure 21: PCR and electrophoresis were done to confirm the identities of the 2 bacterial strains used. The electrophoresis confirmed it was indeed *B. cereus* and *V. alginolyticus* present. L1 is the GeneRuler molecular weight marker (1Kb). The DNA fragments of *V. alginolyticus* (L5) and *B. cereus* (L11). The sizes of the DNA fragments were as follows 737 bp and 1686 bp respectively (Picture supplied by author).
- ❖ Figure 22 (A-B): Hep G2 cells were treated with the extracts from *B. cereus* and *V. alginolyticus*. The MTT assay showed a decrease in Hep G2 cell viability as the dilution decreases Cell viability assay with Hep G2 cells tested against the extracts of *B. cereus* and *V. alginolyticus*. There is a decrease in HepG2 cells as the dilution decreases.
- ❖ Figure 23: Hep G2 cells were treated with extract 1 (*B. cereus*) and extract 2 (*V. alginolyticus*) for 24 hours. After 24 hours, the Annexin V assay was used to determine early apoptosis. From the above results, the apoptosis caused by the extract from *B. cereus* extract was higher than the control. This however was not significant. On the other

hand, apoptosis caused by the *V. alginolyticus* extract was significant when compared to the control.

- ❖ Figure 24: Extract 1 and 2 showed a higher propidium percentage than the control. There were no significance.
- ❖ Figure 25: The ATP levels observed when Hep G2 cells were treated with extract 1 and 2 and the untreated cells. Extract 1 and 2 showed a decrease in ATP levels with reference to the control. There were no significance in the ATP levels determined.
- ❖ Figure 26: The effect of the *B. cereus* and *V. alginolyticus* extracts on Hep G2 cells after being treated for 24 hours. Here, the mitochondrial depolarisation is not significant when compared to the control. The cells exposed to the extracts have a higher mitochondrial depolarisation than the control cells. These results are re-emphasizing the results observed with ATP assay. Both assays showed that the cells' ATP levels were decreased and this can be observed when the cells are undergoing apoptosis.
- ❖ Figure 27: The caspase activities of caspase 3/7, 8 and 9 on Hep G2 cells when they were treated with the extracts. In figure 27 A, the caspase activity for caspase 8 was higher for extract 1 while for figure 27 B, the caspase activity was higher for extract 2 when compared to the control and other extract. Figure 27 C showed that both extracts caused a higher caspase 3/7 activity than the control cells. There were no significance in these caspase activities.
- ❖ Figure 28 A: Hep G2 cells were observed to be circular in shape for the control cells (Pictures were supplied by author).
- ❖ Figure 28 B: Comets were observed when Hep G2 cells were treated with the *B. cereus* extracts for 24 hours (Pictures were supplied by author).

- ❖ Figure 28 C: Comets were observed when Hep G2 cells were treated with the *V. alginolyticus* extracts for 24 hours (Pictures were supplied by author).
- ❖ Figure 28 A-D: Intact cells and comets were observed under the microscope for the comet assay (A-C). A) Intact cells were observed by the untreated cells. B) Comet tails were observed when Hep G2 cells were treated with extract 1. C) Comet tails were observed when the Hep G2 cells were treated with extract 2. D) Comet analysis of the two extracts and the control. The extracts were significantly higher than the control. Extract 1 and 2 were compared to each other and had shown a significance between them. The comet assay indicated that both extracts have a significant degree of DNA fragmentation on the Hep G2 cells. The comparison between the two extracts indicated that *B. cereus* extract was more toxic and therefore had a higher level of DNA fragmentation.

## Chapter 4

- ❖ Figure 29: Diagram of the intrinsic and extrinsic pathway of apoptosis. It also shows the caspase that are involved in the respective pathways. The left hand side of the diagram is the extrinsic pathway while the right hand side is the intrinsic pathway. The death receptors that are activated by ligands will promote the assembly of death-inducing signal complex (DISC). This then activates caspase 8 and perhaps, caspase 10. This then causes the cleavage of effector caspase such as caspase 3, 6 and 7. Caspase 8 also activates Bid which is the link between the intrinsic and extrinsic pathway. In the intrinsic apoptotic pathway, many intracellular signals such as DNA damage and endoplasmic reticulum

stress (ER) come together on the mitochondria and induce mitochondrial membrane permeabilization (MMP). This will then free the pro-apoptotic factors. One of these factors is cytochrome c which is responsible for the activating apoptosis protease-activating factor 1 (APAF-1) and ATP/dATP. This then allows for the assembly of the apoptosome which is responsible for the activating the proteolytic activity of caspase 9. Caspase 9 then cleaves and induces caspase 3, 6 and 7. This then leads to apoptosis (Kroemer et al., 2007).

- ❖ Figure 30 (A-C): IC<sub>50</sub> values were determined by the MTT assay for different toxins on the different cell lines used (Serandour et al., 2012).
- ❖ Figure 31 (A, C, E): The caspase activities of caspase 3,-8 and -9/6 when exposed to TLH from *V. alginolyticus*. The activities increased significantly when incubated with TLH. The control was TRIS-HCL while cells were treated with 0.5µg/ml, 1.0 µg/ml and 2.0 µg/ml of TLH. The a and b denotes the significant difference between the mean values (p<0.05) (Wong et al., 2012).
- ❖ Figure 32: Double staining of green fluorescence and PI staining were done. Intact DNA (control group) fluorescence red while DNA that was fragmented fluorescence yellowish green (Wong et al., 2012).
- ❖ Figure 33: Pictures A-D depicts the control cells that were not exposed to TLH while pictures I-J depicts the cells that were exposed to TLH. The cells that were treated with TLH have protrusions and showed vesiculation on the plasma membrane.

## List of Tables and Description

### Chapter 1

- ❖ Table 1: Sharks found along the coastline of Kwa-Zulu Natal (KWAZULU- NATAL SHARKS BOARD. SHARK SPECIES. <http://www.shark.co.za/SharkSpecies>. Accessed on 03/05/2013, 1:23 pm).
- ❖ Table 2: List of Endangered Sharks Species (Adapted from (Verlecar et al., 2007)).
- ❖ Table 3: List of the unknown status of the endangerment of the following shark species (Adapted from (Verlecar et al., 2007)).
- ❖ Table 4: The average amounts of the different factors considered for the assessment of the quality of water along the UMhlatuze River (Mthembu et al., 2012).
- ❖ Table 5: Reported microbes that produce bioactive products (Soria-Mercado et al., 2012).
- ❖ Table 6: Bacteria isolated from different sources and their respective biological activities (Adapted from Table VIII, (Kelecom, 2002)).

### Chapter 2

- ❖ Table 7: Forward and Reverse Primers used for the identification of the bacteria.

### Chapter 3

- ❖ Table 8: The mean of absorbance and the MDA concentrations obtained using the TBARS assay

## Contents

1) Abstract	2-5
2) Declaration	6-6
3) Acknowledgements	7-9
4) List of Abbreviations	10-14
5) Reference strains used for antibacterial testing	14-14
6) List of Figures and their Description	15-20
7) List of Tables and Description	21-21
8) Contents	22-26
9) Introduction	27-27
10) Aims	28-28
11) Objectives	28-28
12) The Ocean, Marine Diversity and the Role of sharks	29-32
13) Endangerment of the shark species	32-35
14) Water pollution and the microbes found in the water	35-36
15) Kwa-Zulu Natal' s polluted water	36-39
16) Diseases and pollutants that affect sharks	40-40
17) Biologically active products from marine bacteria and fungi	41-41
18) Marine bacteria as a source of secondary metabolites	41-42
7.1 <i>Vibrio</i> Species	42-43
7.2 <i>Bacillus cereus</i>	44-45
7.2.1 Mechanism of Nhe, HBL, CytK and cereulide	45-47
7.2.2 Production of Zwittermicin by <i>B. cereus</i>	47-47

19) Uses of Secondary metabolites	48-51
20) Cytotoxic secondary metabolites	51-51
9.1 Anticancer activity	51-52
21) Resistance to antibiotics	52-53
22) Issues contributing to resistance to antimicrobial activity	53-54
23) Chapter 2 - Methods	55
24) Study Samples	55-55
25) Sub-culturing of bacteria and storing of bacteria	55
26) Method	55-55
27) Antibiotic assay	55-56
28) Method	56-57
29) Extraction of DNA from bacteria	57
30) Method	57-57
31) Assessing DNA Quality	57-58
32) Method	58-58
33) Optimization of Primers	58
34) Method	58-59
35) Amplification of DNA	59
36) Method	59-59
37) Gel Electrophoresis	59-60
38) Method	60-60
39) PCR and electrophoresis	61-61
40) Method	61-61

41) Production of Secondary metabolites	62
42) Method	62-62
43) Extraction of secondary metabolites	62
44) Method	62-62
45) Culturing of Hep G2 Cells	63
46) Method	63-63
47) Cell viability assay (MTT assay)	63-64
48) Method	64-64
49) Flow cytometry and Luminometry	65
50) Adenosine triphosphate (ATP) assay	65-66
51) Mitochondrial depolarization	67-68
52) Apoptosis and Annexin V	68-70
53) Caspases 8	70-71
54) Caspase 9	71-71
55) Caspase 3/7	71-75
56) Preparation for Assays	75-76
57) Method	76-77
58) Comet assay	77-77
59) Method	78-78
60) Thiobarbituric acid reactive substances (TBARS)	78-79
61) Method	79-79
62) Statistical analysis and primers	79-79
63) Chapter 3 – Results	80



64) The testing of secondary metabolites for antibacterial activity on nutrient agar	80-81
65) DNA extracted from bacteria	81-81
66) Polymerase Chain Reaction (PCR) of <i>B. cereus</i> and <i>V. alginolyticus</i>	82-82
67) Cell viability assay (MTT)	83-84
68) Annexin V-FLUOS and Propidium Iodide (PI)	84-86
69) Adenosine triphosphate (ATP) assay	86-86
70) Mitochondrial depolarisation	87-87
71) Thiobarbituric acid reactive substances (TBARS)	88-88
72) Caspase Activity	88-90
73) Comet assay	90-93
74) Chapter 4 – Discussion	94-95
75) Zone of Inhibition Test	95-95
76) PCR	95-96
77) Cell viability assay (MTT)	96-96
78) Annexin V and propidium staining	96-97
79) Adenosine triphosphate (ATP) assay	97-98
80) Mitochondrial depolarisation	98-99
81) Thiobarbituric acid reactive substances (TBARS)	100-100
82) Caspase Activity	100-102
83) Comet assay and summary of all assays done	103- 104
84) <i>Bacillus cereus</i> ' enterotoxins	105-105
85) Lipophilic phycotoxins tested on different cell lines	105-107
86) <i>Bacillus cereus</i> ' emetic toxin tested on Hep G2 and Hep-2 cells	107-107

87) Thermolabile hemolysin (TLH) from <i>Vibrio alginolyticus</i>	108-109
88) DNA fragmentation by TUNEL assay	109-109
89) Morphological changes in erythrocytes	110-110
90) Effect of TLH dosage on necrosis and DNA fragmentation	111-112
91) Chapter 5 – Conclusion	113-114
92) References	115-122

## **Introduction**

There are approximately 2.4 billion people living in urban and rural areas that do not have access to basic sanitation. It is estimated that within 20 years, there will be a further 2 billion people living in towns and cities (mainly in developing countries), requiring basic sanitation. In developing countries, a high percentage (90 %) of sewage is untreated and discharged into lakes, rivers and coastal areas (Langergraber and Muellegger, 2005). Human activities aid in the marine pollution with petroleum products, heavy metals and organochlorine compounds (Narracci et al., 2013).

After the United Nations' Earth Summit (1992), which was held in Rio de Janeiro (Brazil), issues about environmental pollution, exploitation and the scarcity of natural resources by mankind, have been discussed ever since. There is a huge amount of pollution and waste being released into the environment. This is due to an ever increasing population, urbanisation and people migrating into cities. The destitute are affected the most, especially women and children in developing countries. Many get ill with water-related diseases and suffer from the damaged environment (Langergraber and Muellegger, 2005).

The Indian Ocean's pollution is increasing due to excess waste products, faecal matter, poisonous metals etc. Some of these pollutants encourage the growth of pathogenic bacteria. The marine species are exposed to both the pollutants and these microbes. The fish and other marine life that are consumed by humans pose a health risk. In sharks, these bacteria remain on their teeth and gums.

**Aims:** This study investigated the cytotoxic effects of the metabolites produced by *Bacillus cereus* and *Vibrio alginolyticus* (isolated from the mouth of dead sharks) in the human liver hepatocellular carcinoma (Hep G2) cells.

**Objectives:**

- 1) To collect bacterial samples from the dead shark's mouths.
- 2) To isolate and culture these bacterial species.
- 3) To extract the bacterial DNA as well as amplify and identify the bacteria by performing PCR
- 4) To extract secondary metabolites from the bacteria growing in broth with ethyl acetate
- 5) To perform the zone inhibition assay on all the bacterial secondary metabolites against *Staphylococcus aureus* ATCC 25923, *Escherichia coli* ATCC 25922 and *Pseudomonas aeruginosa* ATCC 27853.
- 6) To determine the toxicity of isolated bacterial extracts on liver cells (Hep G2).
- 7) To determine oxidative stress using lipid peroxidation assay in Hep G2 cells.
- 8) To determine apoptosis using mitochondrial depolarisation, Annexin V/ propidium iodide staining and the caspase assays.

## Chapter 1- Literature Review

### 1) The Ocean, Marine Diversity and the Role of sharks

The ocean is a diverse place for many marine creatures, plants etc. (Nybakken and Webster, 1998). Likewise is the Indian ocean, displaying many of nature's fascinating marine life (Wafar et al., 2011) as can be seen in Figure 2 (Nybakken and Webster, 1998). The area that the Indian ocean covers is depicted by Figure 1 (Wafar et al., 2011). Apart of this fascinating marine life are different species of sharks (Davidson et al., 2011).



Figure 1: An illustration of the Indian Ocean boundary (Wafar et al., 2011).



Figure 2: The Marine Diversity that exists in the Ocean (Nybakken and Webster, 1998).

Sharks play a vital role in the ecological balance of the ocean. They keep the ocean's water clean and they are indicators of the status of the ocean (Verlecar et al., 2007). Sharks have been dominating the ocean for more than four hundred millions years. Currently however, sharks are a vulnerable (Knip et al., 2012) and valuable species of the sea. Sharks are being killed for their fins and other shark-related products (Figure 3-5) (Verlecar et al., 2007). Shark fins have become Asia's precious delicacy (Figure 6) (News, 2012). Internationally, shark products are sold to more than 125 countries. This drastically reduces the population of sharks (Verlecar et al., 2007).



Figure 3: A dead shark with its fins cut off lying on the ocean floor (Verlecar et al., 2007).

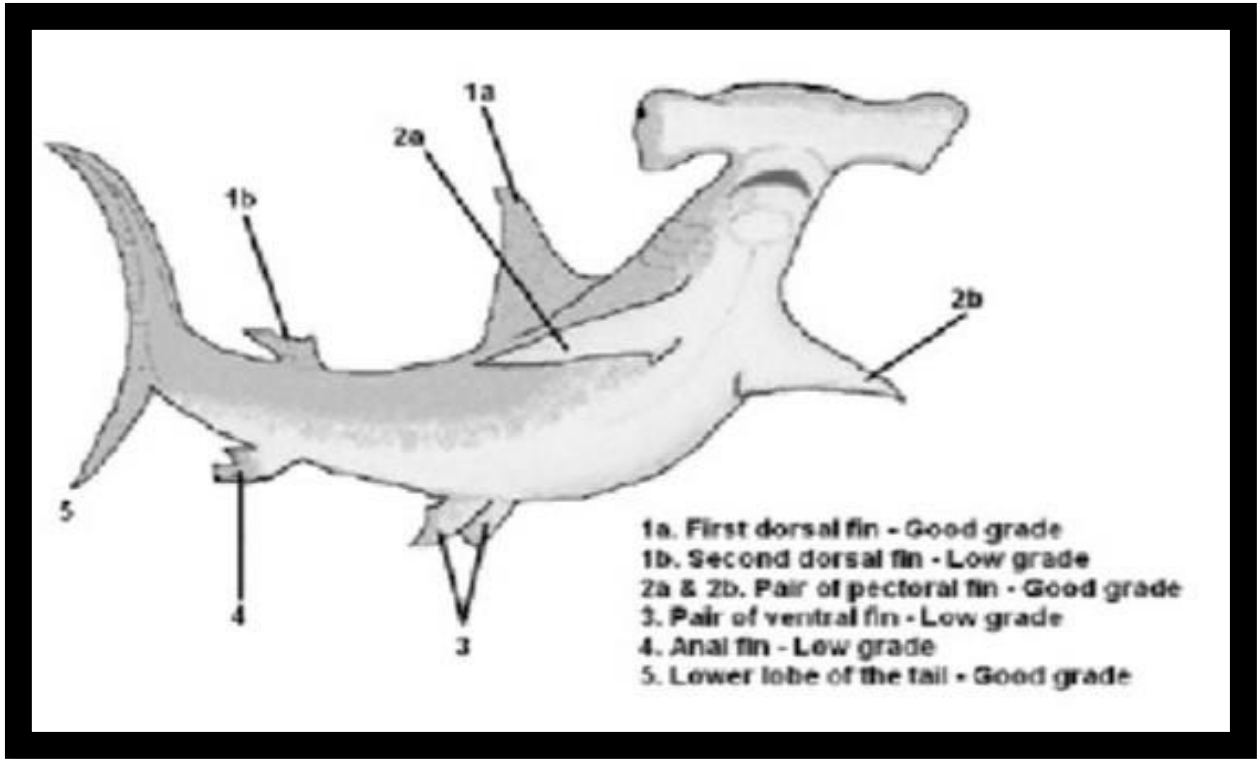

Figure 4: Cost of sharks' fin is determined from which part of the body the fin comes from (Verlecar et al., 2007).

a)

b)

c)



Figure 5: a) Sharks that were finned. b) Shark fins. c) Sharks fins laid out to dry (Verlecar et al., 2007).



Figure 6: A shark-fin soup delicacy (Verlecar et al., 2007).

## **2) Endangerment of the shark species**

It is estimated by the year 2017, 20 species of sharks would be extinct (Verlecar et al., 2007).

The sharks that are found along the Kwa-Zulu Natal coastline as well as the known and unknown endangerment status of sharks are shown in table 1-3. This creates an urgent need to have conservation strategies in place in order to preserve the many shark species. Unfortunately, the conservation of sharks is difficult especially with the wide geographic distribution of sharks as well as the migratory nature of the sharks. Designated marine protected areas and fitting sharks with acoustic transmitters have shown some effectiveness with sharks in the Great Barrier Reef Marine Park (Australia) (Knip et al., 2012).



Table 1: Sharks found along the coastline of Kwa-Zulu Natal (KWAZULU- NATAL SHARKS BOARD. SHARK SPECIES. <http://www.shark.co.za/SharkSpecies>. Accessed on 03/05/2013, 1:23 pm).

Scientific Name	Common Name
<i>Carcharodon carcharias</i>	Great White
<i>Isurus oxyrinchus</i>	Mako
<i>Galeocerdo cuvier</i>	Tiger
<b>Smalltooth (<i>Alopias pelagicus</i>)</b>	Threshers
<b>Thintail (<i>Alopias vulpinus</i>)</b>	
<b>Bigeye (<i>Alopias superciliosus</i>)</b>	
<i>Carcharhinus leucas</i>	Zambezi
<i>Carcharhinus amboinensis</i>	Java
<i>Carcharhinus obscurus</i>	Dusky
<i>Carcharhinus plumbeus</i>	Sandbar
<i>Carcharhinus limbatus</i>	Blacktip
<i>Carcharhinus brevipinna</i>	Spinner
<i>Carcharhinus sealei</i>	Blackspot
<i>Carcharhinus brachyurus</i>	Copper
<i>Negaprion acutidens</i>	Sicklefin lemon
<i>Carcharias taurus</i>	Raggedtooth
<i>Triakidae</i>	Houndshark
<i>Rhizoprionodon acutus</i>	Milk shark
<i>Sphyrna mokarran</i>	Great hammerhead
<i>Sphyrna lewini</i>	Scalloped hammerhead
<i>Squatina africana</i>	African angel
<i>Rhincodon typus</i>	Whale shark
<i>Sphyrna zygaena</i>	Smooth hammerhead shark

Table 2: List of Endangered Shark Species (Adapted from (Verlecar et al., 2007)).

<b>Number</b>	<b>Shark</b>
1	Ganges shark
2	Borneo shark
3	Basking shark (North Pacific and Northeast Atlantic sub-populations)
4	Spertooth shark
5	Whitefin Topeshark
6	Angular Angel shark (Brazilian sub-population)
7	Smoothback Angel shark
8	Spinner shark (Northwest Atlantic sub-population)
9	Pondicherry shark
10	Smoothtooth blacktip
11	Blacktip shark (Northwest Atlantic sub-population)
12	Dusky shark (Northwest Atlantic and Gulf of Mexico sub-populations)
13	Grey Nurse shark (also known as Sand Tiger)
14	Great White shark
15	Gulper shark
16	Basking shark
17	School shark (also known as Tope shark)
18	Bluegray carpetshark
19	Porbeagle shark
20	Whale shark

Table 3: List of the unknown status of the endangerment of the following shark species (Adapted from (Verlecar et al., 2007)).

Number	Shark (Common Name)	Scientific Shark Name
1	Thresher shark	<i>Alopias vulpinus</i>
2	Java shark (also known as Pigeeye)	<i>Carcharhinus amboinensis</i>
3	Kitefin shark	<i>Dalatias licha</i>
4	Salmon shark	<i>Lamna ditropis</i>
5	Megamouth shark	<i>Megachasma pelagios</i>
6	Broadnose Sevengill shark	<i>Notorynchus cepedianus</i>
7	Bigeye Sand Tiger	<i>Odontaspis noronhai</i>
8	Narrowmouth catshark	<i>Schroederichthys bivius</i>
9	Great hammerhead	<i>Sphyrna mokarran</i>
10	Argentine Angel shark	<i>Squatina argentina</i>

Apart from sharks being killed for human consumption (Verlecar et al., 2007), sharks are exposed to harmful substances (Austin, 1999). Pollutants can range from hydrocarbons, pesticides, heavy metals, pulp mill effluents, plastics, organic sewage and even toxins (Austin, 1999).

### 3) Water pollution and the microbes found in the water

Polluted marine waters are of a high importance as these waters are used for recreational purposes and for shellfish harvesting. This therefore poses a health problem (Aulicino et al., 2001). Sewage is the main waste disposed off in the sea. It is made up of municipal wastes, faecal matter, animal remains, industrial wastes etc. Sewage effluents contain viral, bacterial and

protozoan pathogens. This sewage has both pathogenic and non-pathogenic microbes. Bacteria (*Staphylococcus aureus* and *Pseudomonas aeruginosa*), viruses (influenza and herpes virus) and fungi (*Candida*) can be found in sewage (Shahidul Islam and Tanaka, 2004). Water-borne pathogens are mainly from untreated sewage, however many human pathogens are indigenous to the sea. Diseases or illnesses may arise from water activities or by consuming contaminated seafood. Bacteria such as *P. aeruginosa* and *S. aureus* can cause ear, skin and eye infection while *Vibrio* species can aggravate ear and wound infections (Wu, 1999).

#### **4) Kwa-Zulu Natal' s polluted water**

Waste water and organic sewage treatment infrastructure in South Africa is lacking (Figure 7). This contributes to pollution of water resources. This incompetency directly affects human health and the environment. In Kwa-Zulu Natal's (KZN) water resources, an increase of faecal coliforms has been recorded. In a period of 1 year (1998-1999), the Mhlathuze River's total coliform counts were double that of the faecal coliform counts. In 2008, the Daily News reported the huge amount of organic sewage flowing into the Durban Harbour (Figure 8). In 2006, the Mlazi River showed a significant increase in the levels of *Escherichia coli*. This was then followed by the Isipingo River. Untreated wastewater and sewage therefore affects human and marine life that feed on these contaminated fish (Mema, 2010).

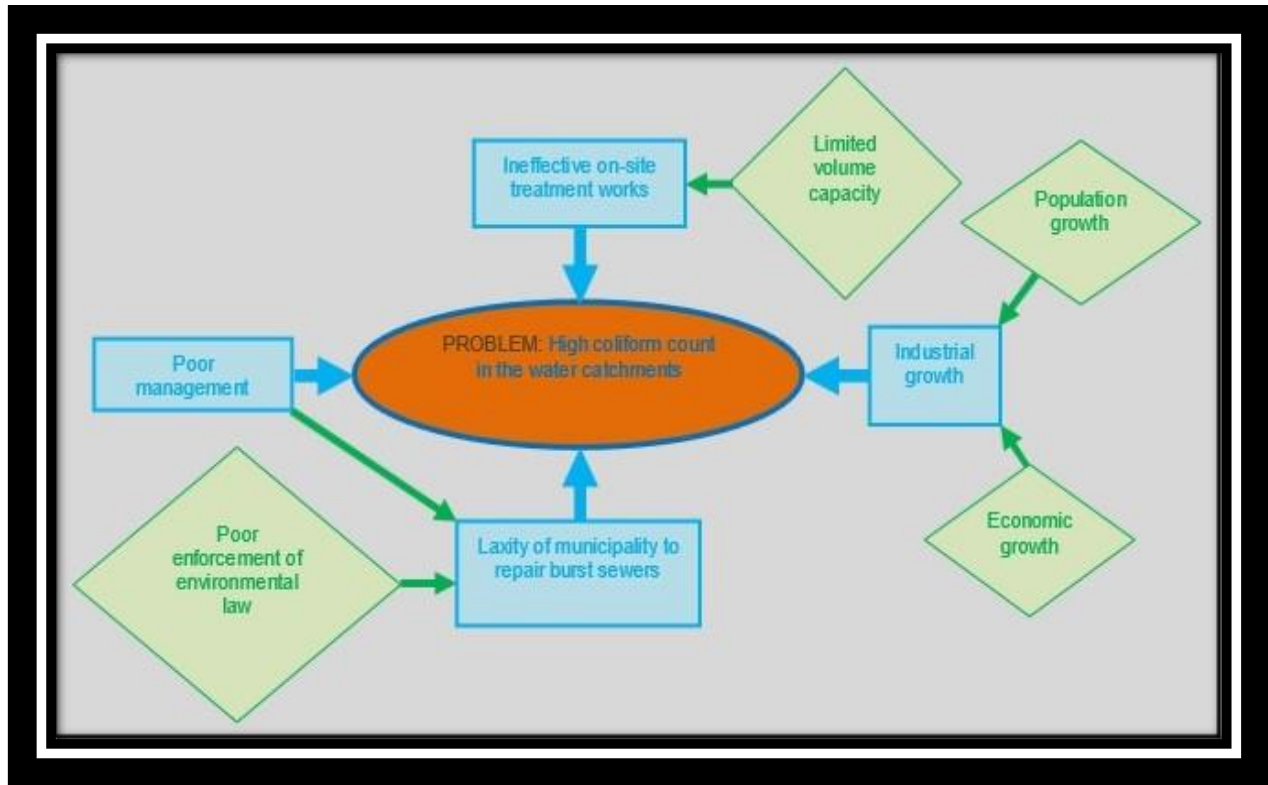

Figure 7: A schematic representation of the factors that contribute to the water pollution in Kwa-Zulu Natal which come from effluents from treatment plants (Mema, 2010).



Figure 8: The pollution in Durban Harbour (Mema, 2010).



Figure 9: The 4 sampling sites along the Umhlathuze River. The number 1 represents Felixton Bridge; 2 represents Kwa-Dlangezwa; 3 represents Mzingazi and 4 represents UMhlathuze (Mthembu et al., 2012).

A study done on the Umhlathuze River (i.e. a river from Eshowe to the Indian Ocean in Richards Bay), revealed this river receives domestic sewage, industrial and agricultural waste. Kwa-Dlangezwa, UMhlathuze station, Mzingazi and Felixton Bridge were sites chosen for sampling of the river (Figure 9). Treated wastewater that flowed in certain parts of the river showed a high level of sulphide, ammonia and nitrate. Industrial areas had a high level of ammonia, nitrate and phosphate (Table 4). Microbes such as *E. coli* and species of *Enterobacter*, *Salmonella*, *Citrobacter*, *Shigella* and *Serratia* were found in all 4 sites. The contamination was caused by mining activities by companies like Mzansi Sand Supply, Exxaro and Ninias Query. The effluents of these mining activities increase chemical and microbial contamination. Felixton

Hulett's that produces sugar, artificial sweeteners etc. and also minor farming activities that use fertilizers for growing crops will cause eutrophication as the un-used fertilizer gets washed into rivers. All of these contribute to the pollution in the UMhlatuze River (Mthembu et al., 2012).

Table 4: The average amounts of the different factors considered for the assessment of the quality of water along the UMhlatuze River (Mthembu et al., 2012).

	Kwa-Dlangezwa	Felixton Bridge	Mhlatuze	Mzingazi	Limits*
Environmental T (°C)	10.8-25.3	15.1-26.2	12.4-26.6	19.8-30.3	N/A
Surface water T (°C)	19	19	21	20	N/A
Rainfall (mm)	96.2	85.4	162	137.6	N/A
Humidity (%)	87	85	89	92	N/A
COD (mg/L)	30	70	23	280	75
BOD (mg/L)	0.44	0.42	0.21	0.11	5
pH	7.8	6.8	6.2	6.5	6-9
Turbidity (%)	1.4	1.4	1.9	1.9	1
Conductivity (mS/m)	48.7	50.8	48	48.7	70
Total suspended solids (mg/L)	10	7	4	4	25
Phosphate (mg/L)	1.6	1.8	0.24	0.2	1
Ammonia (mg/L)	1.2	0.6	0.22	0.2	1
Sulphide (mg/L)	2.6	0.8	0.18	0.12	N/A
Chloride (mg/L)	140	100	100	210	100
Nitrate (mg/L)	0.7	0.6	0.33	0.31	6
Fluoride (mg/L)	0.064	0.057	0.037	0.018	1
Manganese (mg/L)	0.29	0.38	0.34	0.6	0.05
Lead (mg/L)	0.28	0.38	0.5	0.3	10
Aluminium (mg/L)	0.17	0.28	1.4	1.62	0.15
Mercury (mg/L)	N/A	N/A	0.25	0.4	1
Copper (mg/L)	N/A	0.06	0.08	0.08	1
Cadmium (mg/L)	N/A	0.003	0.004	0.004	5
Fecal coliforms (CFU/mL)	350	455	152	220	0
Total coliforms (CFU/mL)	$5 \times 10^4$	$5.5 \times 10^4$	$2 \times 10^4$	$3 \times 10^4$	N/A

\*Department of Water Affairs and Forestry (1996).

## 5) Diseases and pollutants that affect sharks

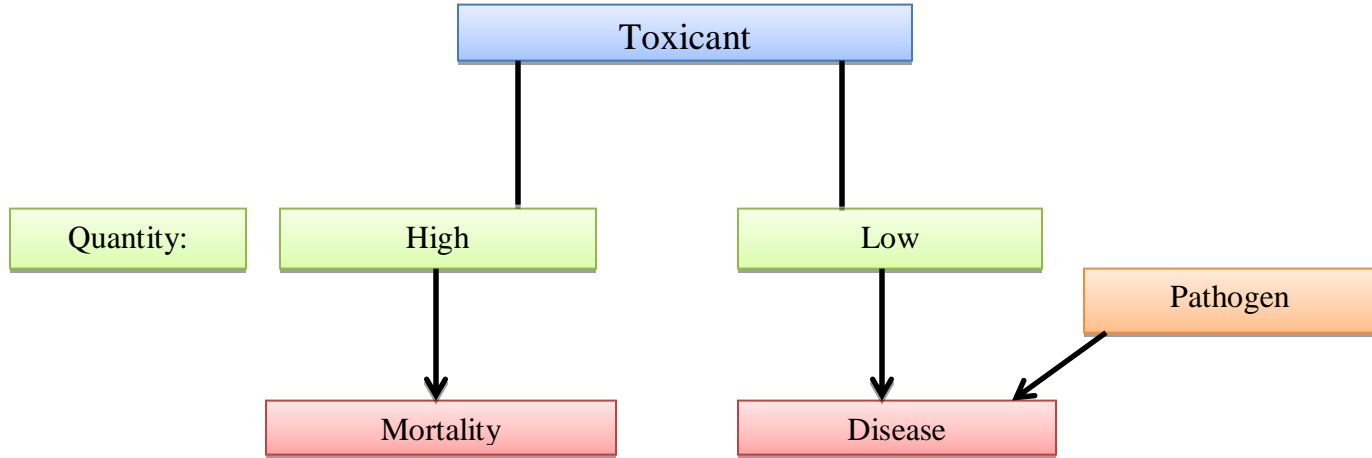

Figure 10: A flow diagram depicting the outcomes of when fish come into contact with a toxicant (Adapted from (Austin, 1999)).

When there is a high concentration of pollutants in the ocean, they can cause the death of marine life (Figure 10). When there is a lower concentration of pollutants, the pollutants will accumulate in the organism (Figure 10) (Austin, 1999). Sharks will accumulate the pollutants greater than other fish (Mortimer, 2007). The pollutant can accumulate in a specific organ or part of the fish (Mortimer, 2007). Lower concentration of pollutants can cause damage to gills, epithelia, decrease in metabolism and immuno-suppression. Possible diseases caused by pollution include fin or tail rot, liver damage, ulceration, neoplasia, hyperplasia, epidermal papilloma and gill disease. Fish disease possibly caused by pollution could be due to surface lesions caused by *Serratia phymuthica*, gill disease caused by *Flavobacterium* spp., fin and tail rotting caused by *Aeromonas hydrophila* and *Pseudomonas fluorescens* and vibriosis caused by *Vibrio anguillarum* (Austin, 1999).



## **6) Biologically active products from marine bacteria and fungi**

The marine water is abundant of diverse life forms. There are approximately  $1 \times 10^6$  bacterial cells in a millilitre that can be found in an oceans water column (Debbab et al., 2010). Marine microbes provide a great potential of bioactive compounds. These microbes live symbiotically with soft bodied marine creatures (Table 6). The microbes lack structural defence mechanisms and thus a chemical type of defence is necessary. This is achieved by the production of biologically active secondary metabolites by themselves or by the surrounding microflora. The role of secondary metabolites is of utmost importance for marine bacteria and fungi to survive in harsh conditions. Over the years, the quantity of secondary metabolites discovered from marine bacteria and fungi have been rising, thus gaining the attention of academia and industry. In 2007, an astounding 961 novel compounds were discovered. There was a 24% increase in natural products found in marine microbes from the year 2006 (Debbab et al., 2010).

## **7) Marine bacteria as a source of secondary metabolites**

Marine bacteria can be a rich source of secondary metabolites (Teasdale et al., 2009). Microbial secondary metabolites are compounds that have a low molecular mass which is not essential in the growth of the bacteria (Ruiz et al., 2010). Bacteria compete against each other for resources. It is therefore likely these secondary metabolites arbitrate microbial interactions (Teasdale et al., 2009). Bacteria such as *Vibrio parahaemolyticus*, *Vibrio alginolyticus*, *Staphylococcus* sp., *Pseudomonas* sp., amongst other genera were found on the teeth of a great white (Buck et al., 1984). *Vibrio* spp. were the most common bacteria found in blacktip sharks in Florida. Other bacteria that were found in the blacktip sharks' mouth were *Staphylococcus* spp. and *Pasteurella*

spp. (Unger et.al., 2014). In the oral cavity of sharks from Recife (Brazil), bacteria such as *Enterobacter* spp., *Proteus* spp., *Escherichia coli*, *Vibrio* spp., *Pseudomonas* spp. and *Staphylococcus* spp., amongst other bacteria were identified (Interaminense et al., 2010)

### **7.1) *Vibrio* Species**

*Vibrios* are curved, rod shaped, Gram negative bacteria (Daniels and Shafaie, 2000). There are more than 63 species in this genus. They are aquatic, autochthonous microbes and they can be found in oceans worldwide. They are a commonly found bacterium which displays changes in their population according to the seasons (Damir et al., 2013).

*Vibrios* are opportunistic pathogens that can cause infection, in both humans and marine creatures. *Vibrio* species such as *Vibrio parahaemolyticus*, *Vibrio hollisae*, *Vibrio mimicus*, *Vibrio cholera*, *Vibrio vulnificus* and *Vibrio alginolyticus* have shown evidence of causing diseases in human. They have been associated with water and seafood-related epidemics of gastrointestinal infection. *Vibrios* have been identified from mucus of fish, gills and intestinal contents. Some *Vibrio* species can cause vibriosis. Vibriosis is a serious contagious illness that affects wild and cultured shrimp, shellfish and finfish (Damir et al., 2013).

*Vibrio alginolyticus* is halophilic and can be found in the ocean. As described above for *Vibrios*, *Vibrio alginolyticus* is an opportunistic pathogen to humans and marine creatures. *Vibrio*

*alginoliticus* is responsible for otitis, wound infections, endophthalmitis after being in contact with polluted seawater or ingestion of uncooked seafood (Zhao et al., 2010).

*Vibrio* species can produce virulence factors such as cytotoxin, lipase, siderophore, adhesive factors, haemagglutinins, enterotoxin, protease, haemolysin and phospholipase. Haemolysin is an exotoxin that lyses the membrane of blood cells. Haemolysin is frequently identified amongst the *Vibrios* species. Once the blood cell has been lysed, this liberates iron-binding proteins such as transferrin, lactoferrin and haemoglobin. The iron can be picked up by siderophores which is then taken up by cell membrane receptors. Haemolysin has a pore-forming activity and it can also act on mast cells, neutrophils and polymorphonuclear cells. This in turn enhances virulence by causing damage to the tissue. There are 4 haemolysins families: thermostable direct haemolysin (TDH family), E1T or haemolysin (HlyA family), thermolabile haemolysin (TLH family) and thermostable haemolysin ( $\delta$ -VPH family) (Zhang and Austin, 2005).

A *Vibrio* species was isolated from Alaskan oysters. It was identified as *Vibrio alginolyticus* by biochemical tests. It was discovered that *V. alginolyticus* possesses a thermostable direct hemolysin-related hemolysin gene i.e. *trh* gene. This *trh* gene was previously only recorded to be present in *Vibrio parahaemolyticus*. The *trh*-like gene from *V. alginolyticus* was cloned and sequenced. The *trh*-like gene showed a 98% homology to the *trh 2* gene of *V. parahaemolyticus* (Gonzalez-Escalona et al., 2006).

## 7.2) *Bacillus cereus*

Bacteria that belong to the genus *Bacillus* are Gram positive or Gram variable spore-forming rods. They are ubiquitous in nature and aerobic or facultatively anaerobic. *Bacillus* can grow optimally at temperatures of 25-37°C. However psychrophilic and thermophilic bacilli can grow at temperatures as high as 75°C or low as 3°C. They can also survive in acidic and alkaline environments which range from pH 2 to pH 10. Examples of *Bacillus* species are *Bacillus anthracis*, *Bacillus thuringiensis*, *Bacillus sphaericus* and *Bacillus cereus* (Drobniewski, 1993).

*Bacillus cereus* is Gram positive, aerobic or facultative, spore-forming rod that can be found in many different places. It is classified as pathogenic or as an opportunistic pathogen (Kotiranta et al., 2000). *Bacillus cereus* can form endospores so it can survive unfavourable conditions such as high temperatures, dehydration and other stresses. When *B. cereus* enters mammalian tissues, it acts as an opportunistic pathogen which has the ability to cause systemic diseases like septicaemia and endophthalmitis. As a result of the adhesiveness of endospores, *B. cereus* can be present in the manufacturing process of food. This therefore aids the spread of the bacteria to many different kinds of food. The bacteria can produce different virulence factors that can cause human disease when it is in food or the gastrointestinal tract. *Bacillus cereus* is known as one of the main food borne pathogens. However in many cases, the illnesses are not severe and lasts for a short period. *Bacillus cereus* strains can be useful e.g. probiotics for humans or health-concerning e.g. highly toxic strains have been associated to food-related deaths. It can cause 2 types of gastrointestinal diseases, which are the diarrhoeal and emetic syndromes. They are caused by different toxins. The emetic toxin (cereulide) is a minute ring formed-peptide, which

causes vomiting. The diarrhoeal disease, on the other hand, is caused by one or many protein enterotoxins. These enterotoxins are suggested to cause diarrhoea by disturbing the integrity of the plasma membrane of the small intestine's epithelial cells. The 3 toxins responsible for the diarrhoeal disease are cytotoxin K (Cyt K), nonhaemolytic enterotoxin (Nhe) and a pore forming cytotoxin, haemolysin B1 (Hbl) (Stenfors Arnesen et al., 2008).

### **7.2.1) Mechanism of Nhe, HBL, CytK and cereulide**

Cereulide is a cyclic dodecadepsipeptide and has a structure: [D-O-Leu-D-Ala-D-O-Val-D-Val]<sub>3</sub>. Cereulide is produced by a non-ribosomal peptide synthetase. This is encoded by the 24 kb cereulide synthetase (*ces*) gene cluster. The toxin is suggested to act as a cation ionopore. It inhibits mitochondrial activity by inhibiting fatty acid oxidation. There has been evidence that showed cereulide caused liver failure of a 17 year old and a 7 old girl. Cereulide has also been observed to cause cellular damage and inhibit human natural killer (NK) cells (Stenfors Arnesen et al., 2008).

Haemolysin BL (HBL) is a 3 component toxin. It is made up of L<sub>2</sub>, B and L<sub>1</sub> which are encoded by *hblC*, *hblA* and *hblD* genes. Haemolysin BL (HBL) has been reported to cause fluid accumulation in ileal loops of rabbits. It has shown to have dermonecrotic activity, cause vascular permeability, have cytotoxicity to Vero cells and retinal tissue and also have haemolytic activity against erythrocytes of many species. A mode of action for Hbl has been proposed according to studies done with erythrocytes, which include osmotic protection studies. The 3

components of Hbl bind to erythrocytes independently, which then assembles into a membrane - attacking composite by forming a transmembrane pore (Stenfors Arnesen et al., 2008).

Nonhaemolytic enterotoxin (Nhe) is a 3 component toxin. It is made up of NheA, NheB and NheC which is coded by the *nheABC* operon. The variants of NheA and NheB have similar biological activity. It was characterised after a food poisoning event in Norway (1995). This outbreak was caused by the *hbl*-negative *B. cereus* strain NVH 0075/95. There was a cytotoxic effect on Vero cells when the molar ratio of NheA, NheB and NheC were c. 10:10:1. There was cytotoxic activity on epithelial cells. It showed to have a disruption of the plasma membrane when exposed to Nhe. There was also a formation of pores in the planar lipid bilayers. Further studies with osmotic protection experiments and an increase in cell size after being exposed to Nhe, suggested that Nhe caused cell death by making transmembrane pores by colloid osmotic lysis. Nhe has haemolytic activity against erythrocytes from many mammalian species in suspension assays. The level of haemolytic activity Nhe and Hbl has not been studied yet. It is also quite possible that Nhe has shown to be nonhaemolytic on bovine blood agar plates, since it had a lower haemolytic activity than that of Hbl (Stenfors Arnesen et al., 2008).

*Bacillus cereus* generates 2 single component protein toxins. These toxins belong to the  $\beta$ -barrel pore forming toxin family. They are CytK and HlyII. The most known member of the toxin family is the  $\alpha$ -haemolysin of *Staphylococcus aureus* and the  $\beta$  toxin of *C. perfringens*. The toxins are released as water-soluble components that become oligomeric prepores of the surface of the target cell. This causes pore-forming regions in the cell membranes which in turn forms a

trans-membrane pore. CytK is a 34 kDa protein. It has dermonecrotic haemolytic and cytotoxic activities. It has shown similar cytotoxic activity toward cells like Nhe and Hbl (Stenfors Arnesen et al., 2008).

*Bacillus cereus* enterotoxins are unstable toxins and will denature at temperature of 55 °C and higher, over a period of 20 minutes or more. Enzymes such as pronase, trypsin, pepsin and chymotrypsin have protease activity on the toxin. Therefore *B. cereus* enterotoxins will not be active after cooking of food and once it is in the gastrointestinal passage. However the emetic toxin, cereulide, can withstand high temperatures, acid and protease activity of pepsin and trypsin. It can also remain active when it enters the gastrointestinal passage. It therefore plays a role in emetic food poisoning (Ceuppens et al., 2012).

Detection methods such as mass-spectrometry and immunological assays can be used to determine if enterotoxins exist. These methods are highly specific and sensitive but it is time consuming, labour intensive and has high maintenance costs (Ceuppens et al., 2012).

### **7.2.2 Production of Zwittermicin by *B. cereus***

*Bacillus cereus* produces an antibiotic named zwittermicin A. Zwittermicin A is effective against some Gram positive and Gram negative bacteria as well as eukaryotic microbes. It can also enhance the toxin produced by *Bacillus thuringiensis*. This toxin has the ability to kill gypsy moths (Emmert et al., 2004).

## **8) Uses of Secondary metabolites**

For decades, nature has been a major participant in the discovery of drugs for human medical purposes (Figure 5). A source of these drugs comes from the marine environment, which covers approximately a third of the earth's surface. Biological marine products play a significant role in biomedical research and drug development. This could be as drugs itself or as a basis for synthesized drugs. Biological marine products found particularly from macro-organisms have gone through clinical trials. In the last decades, there has been a reduction in the discovery of new compounds from marine macro-organisms. Therefore chemists have focussed their interest in marine fungi and bacteria for the discovery of natural products. The marine environment is a reservoir for metabolic diversity. This diversity therefore encouraged a great amount of research to be done on marine microorganisms and their natural products over the years, which can contribute to the cosmetic, drugs, personal-care products etc. industries. The advantage of using microbes compared to macro-organisms for the production of secondary metabolites is the cost factor. It is cost effective and provides a sustainable production of the secondary metabolites by growing the microbes by large-scale cultivation and fermentation. The marine environment is very different to other environments. This causes the marine microbes to adapt to survive in the marine waters. The difference in environment allows for the production of distinctive bioactive secondary metabolites which are exclusive to the marine environments (Debbab et al., 2010).



Table 5: Reported microbes that produce bioactive products (Soria-Mercado et al., 2012)

Bacteria	Gram (+ or -)	Activity	Target organism	Disease	Source	Bibliography
<i>Pseudomonas bromoutilis</i>	-	Anticancer	<i>Staphylococcus aureus</i> , <i>Streptococcus pneumoniae</i> , <i>Streptococcus pyogenes</i>	Pneumonia, osteitis, arthritis, endocarditis, localized abscesses	Puerto Rico	Burkholder et al., 1966
<i>Chromobacteria marinum</i>	-	Antibacterial	<i>Escherichia coli</i> , <i>Pseudomona aureginosa</i> , <i>Staphylococcus aureus</i>	Pneumonia, osteitis, arthritis, endocarditis, localized abscesses	Seawater Of North Pacific	Anderson et al., 1974
<i>Flavobacteria uliginosum</i>	-	Anticancer	Sarcoma-180 cells	Viral tumor	Macroalgae (Sagami Bay Japan)	Okami, 1986
<i>Bacillus sp.</i>	+	Anticancer	HCT-116 cells	Colorectal Cancer	Mud near the Arctic Pole	Zhang et al., 2004
<i>Lactococcus lactis</i>	+	Anticancer	Human papilloma virus type 16 (HPV-16)	Cervical Cancer	Designed	Bermúdez-humarán et al., 2005
<i>Staphylococcus aureoverticillatus</i>	+	Anticancer	Tumor cells	Tumors	Marine sediments	Blunt et al., 2005
<i>Marinobacter drocarbonoclasticus</i>	-	Antibacterial (siderofore)	<i>Mycobacteria tuberculosis</i> , <i>Bacillus anthracis</i>	Tuberculosis, carbuncle (anthrax like)	Seawater	Pfleger et al., 2008

Table 6: Bacteria isolated from different sources and their respective biological activities

(Adapted from Table VIII, (Kelecom, 2002).

Biological activities	Bacteria		
	no.	%	origin
antitumor	17	37	alcyonarian (2); alga (1); fish (1); mollusk (2); sediment (8); sponge (1); tunicate (1); wood (1)
antibacterial	21	45	alga (3); mollusk (1); sediment (8); sponge (4); tunicate (1); water (3); worm (1)
antiviral	2	4	sediment (2)
antifungal	–		–
anti-inflammatory	1	2	jellyfish (1)
enzymatic inhibition	4	8	mollusk (1); sediment(1); undefined (1); water (1)
others	2	4	mollusk(1); undefined (1)
<i>sub-total</i>	<i>19</i>	<i>40</i>	<i>sediments only</i>
<i>sub-total</i>	<i>5</i>	<i>11</i>	<i>sponges only</i>
<i>sub-total</i>	<i>4</i>	<i>9</i>	<i>algae only</i>
Total	47	100	–

Research on marine biological products have an unexploited potential. The significance of finding new natural products from microbes only began after the large-scale manufacturing of the antibiotic, penicillin, during World War II. After World War II, pharmaceutical enterprises redirected their attention to the discovery of new bioactive products. In the 1970's, inhibitors for treating heart disease were discovered. These were compactin and mevinolin. They aided in the progression of effective statin therapeutics and which are still considered effective today. Streptomycin, omegamycin and gentamicin are all antibiotics that urged pharmaceutical

companies to start research and start the development of programs on the search of bioactive molecules. There has been a recent focus on marine microbial fermentation technology (Debbab et al., 2010).

## **9) Cytotoxic secondary metabolites**

Marine microbes are taxonomically different, which makes them excellent potential sources of novel drugs. Research on secondary metabolites that can be possible anticancer drugs is a major focus. In 1997, a depsipeptide compound was discovered from a mycelial extract of the *Micromonospora marina* bacteria which is associated with the marine soft coral of the Indian coral of the Indian Ocean. A pharmaceutical company called PharmaMar is doing pre-clinical trials on thiocoraline which was observed to inhibit DNA polymerase- $\alpha$ . An extract from the marine fungus *Curvularia* sp. which was found on the red alga, *Acanthophora spicifera*, had shown activity on human cancer cell lines (Debbab et al., 2010).

### **9.1) Anticancer activity**

There is an increase in cancer cases and this places a huge strain on medical establishments. The figure below (Figure 11) shows the features of carcinogenic and normal cells with regard to their respective cell lines. Medication that is used for treating cancer has brought about secondary toxicity or resistance. This therefore urges for novel anticancer compounds to be found. Natural sources like plants have provided compounds such as vincristine, taxol, vinblastine and

camptothecin. Marine organisms have shown some hopeful results when used at different stages of cancer.

a)

b)

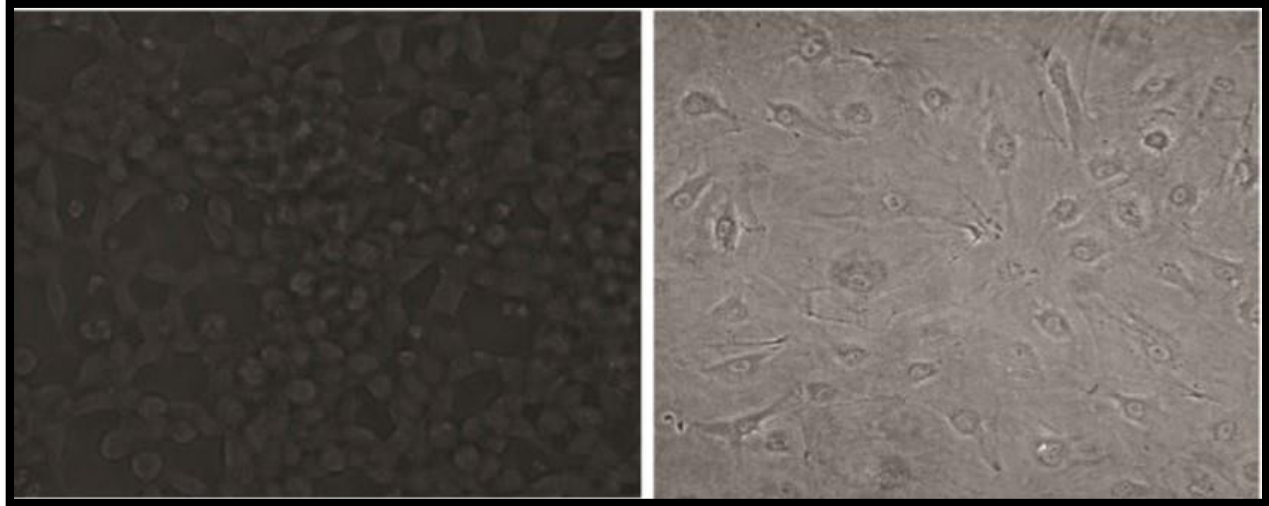

HEK293T cells (20X)

HCAEC cells (20X)

Figure 11: Cells representing carcinogenic and normal cells. a) Human Embryonic Kidney Cells (HEK293T cells) b) Human Coronary Artery Endothelial Cells (HCAEC cells) (Soria-Mercado et al., 2012).

### **10) Resistance to antibiotics**

When an antibiotic is no longer effective against a microbe, this is known as resistance.

Microbes such as bacteria, virus and parasites have the ability to counteract the activity of antibiotics. Resistance is caused by mutations within the microbe or by obtaining resistance genes. The microbes who are resistant to antibiotics make the treatment of patients difficult and could lead to death (Soria-Mercado et al., 2012).

There is around 440 000 new cases of multi-resistant tuberculosis (TB) that kill 150 000 per a year. In South East Asia, *Plasmodium falciparum* is resistant to treatment with artemisinins. The HIV virus has also shown resistance to antiretroviral medication (Soria-Mercado et al., 2012).

People who get infections in hospitals are more likely to be infected by Methicillin Resistant *Staphylococcus aureus* (MRSA), *Enterococcus faecium* and Gram negative bacteria that are resistant to Vancomycin. Bacteria develop strategies to overcome the effects of antimicrobial drugs on them.  $\beta$ -lactamase, which is now called NDM-1, is an enzyme that is resistant to  $\beta$ -lactam medications. The enzyme is bound to genes that move between the common bacteria. There is no treatment or few treatment possibilities for bacteria that produce NDM-1 (Soria-Mercado et al., 2012).

### **11) Issues contributing to resistance to antimicrobial activity**

The World Health Organisation (WHO) states that there are many factors that contribute to resistance of antibiotics. The government is not committed to finding solutions to this problem. The lack of responsibility and participation of antibiotic providers as well as consumers also aid this problem. The providers should dictate the correct procedure of taking medication. When antibiotics are used incorrectly or unnecessarily, this can lead to resistant microbes (Soria-Mercado et al., 2012).

Information about antibiotic resistance is important too, as to aid politicians in making suggestions on this matter and also on monitoring the situation. Diagnosis of diseases is crucial as if there is no diagnosis made, this leads to many medications being used to treat and prevent the disease. There is a need to also invest in research to solve the problem with antibiotic resistance (Soria-Mercado et al., 2012).

The WHO has been paying attention to the antibiotic resistance problem by providing technical assistance, gathering of knowledge, prevention of illnesses such as TB, HIV, malaria, sexually transmitted diseases (STD), diseases that affect children and also hospital infections. They are providing the quality, supply and advice on essential medications, ensuring the safety of patients and making sure laboratories are certified laboratories (Soria-Mercado et al., 2012).

On World Day of Health in 2011, the WHO called to control the spread of antibiotic resistant by passing legislations, so the government can resolve the antibiotic resistance issues (Soria-Mercado et al., 2012)

## Chapter 2 - Methods

### Study Samples

Bacterial samples used for this research project were selected from a previous study. The bacteria were collected from the sharks' oral cavities. The sharks were caught in the nets along the Kwa-Zulu Natal coastline. They were then taken to the KwaZulu-Natal Sharks board in uMhlanga Rocks, where the bacterial samples were collected. Originally, there were 8 bacteria that were selected from the previous project. However, *B. cereus* and *V. alginolyticus* showed the highest toxicity for the cell viability test and were therefore used in all the subsequent assays.

### Sub-culturing of bacteria and storing of bacteria

#### Method

Bacteria were grown on nutrient agar. They were sub-cultured to allow for the isolation of pure cultures. The bacteria were then stored in Cryovials with glass beads. Tryptone soya broth supplemented with glycerol was the media used for their storage. These vials were then stored in a freezer at -70 °C.

### Antibiotic assay

In the disc test, paper discs were embedded with antibiotics. The agar was inoculated with the bacteria of interest. The discs were secured on the agar surface (Figure 12). The plates were then incubated. After incubation, if a zone of inhibition surrounds the paper disc, this indicated that

the bacteria may be susceptible to that specific antibiotic. This test was effortless. However a few considerations need to be taken into account when performing the assay. These are the depth of the agar, medium composition, conditions of the incubation and the inoculum size. If these factors are not taken into consideration, the results will be inaccurate (Rolinson and Russell, 1972)



Figure 12: An example of clinical isolates causing zones of inhibition when tested against *E. coli* using the zone of inhibition method (Pabba et al., 2011).

## Method

The antibiotic assay was carried out as described by (Newbold et al., 1999) but with a few exceptions. *Staphylococcus aureus* ATCC 25923, *Escherichia coli* ATCC 25922 and *Pseudomonas aeruginosa* ATCC 27853 were inoculated on nutrient agar at 37 °C. After 24 h, the *S. aureus* ATCC 25923, *E. coli* ATCC 25922 and *P. aeruginosa* ATCC 27853 were adjusted to



0.5 McFarland standard in PBS. The 3 reference strains were plated by autoclaved cotton swabs. The plates were left to dry. The secondary metabolites were pipetted on sterile filter paper discs of a volume of 10 µl. The concentration factors were 1X, 5X, 10X, 20X and 50X for each extract. The solvent that was used for the negative control was PBS. Ceftriaxone (30 µg) was the positive control. The paper discs were left to dry and once they dried, they were placed on the agar and incubated at 37°C for 24 h. This was then done in triplicate.

## **Extraction of DNA from bacteria**

### **Method**

Pure colonies from the nutrient agar plate were grown in nutrient broth. The extraction was done according to <http://www.nslc.wustl.edu/elgin/genomics/Bio3055/IdUnknBacteria06.pdf>, with the exception of centrifuging at 13 000 rpm for 10 min (last step in manual) and the addition of the supernatant being transferred to sterile micro-centrifuge tubes. The DNA was stored at -20 °C until further use.

### **Assessing DNA Quality**

The Thermo Scientific NanoDrop spectrophotometer was an excellent machine to determine the quality of nucleic acid samples. It was rapid and cost effective. A minute volume was required to check the quality of the nucleic acid and proteins. As the machine was simple and efficient, it allows researchers to process more samples. This then allows for many quality control steps to be

done throughout a process (Thermo Fischer Scientific-Nanodrop Products, Assessment of Nucleic Acid Purity, Technical Bulletin - NanoDrop Spectrophotometer).

Nucleic acids (DNA and RNA) and proteins have a maximum absorbance at 260 nm and 280 nm respectively. The absorbance indicates the purity of the sample. If the value of  $A_{260}/A_{280}$  ratio was ~1.8, this was considered as a “pure” sample of DNA. If the value of the  $A_{260}/A_{280}$  ratio was ~2.0, this was considered as a “pure” sample of RNA (Thermo Fischer Scientific-Nanodrop Products, Assessment of Nucleic Acid Purity, Technical Bulletin - NanoDrop Spectrophotometer).

## **Method**

The quality and the concentration of DNA were determined using the NanoDrop machine. The concentration was then standardized to 20 ng/ $\mu$ l.

## **Optimization of Primers**

### **Method**

For the optimization of the bacterial primers, 5  $\mu$ l of buffer, 1.5  $\mu$ l of  $MgCl_2$ , 2  $\mu$ l of dNTP's, and 1  $\mu$ l of Taq polymerase were used. Primers concentrations used were 10, 20, 40, 60, 80 and 100 pmol. The volume of water differed for each primer concentration to make up a volume of 22  $\mu$ l.

Lastly 3 µl of the respective DNA were added to each tube. In the blank tubes, 3 µl of nuclease free H<sub>2</sub>O was added instead of the DNA. Primers used were as follows (Table 7).

Table 7: Forward and Reverse Primers used for the identification of the bacteria

Bacteria	Forward primer 5'-3'	Reverse primer 5' – 3'	Size (bp)	Reference
<i>Bacillus cereus</i>	TGAAAACCTGAACGAAACAAAC	CTCTCAAAAACCTGAACAAAACGAAA	1686	(Sacchi et al., 2002)
<i>Vibrio alginolyticus</i>	CGAGTACAGTCACTTGAAAGCC	CACAACAGAACTCGCGTTACC	737	(Di Pinto et al., 2005)

## Amplification of DNA

### Method

The initial denaturation was at 95 °C for 5 min followed by 35 cycles of denaturation at 95 °C for 30 sec, annealing at 57 °C for 30 sec and extension at 72 °C for 30 sec. This was then followed by a final extension of 7 min at 72 °C.

### Gel Electrophoresis

Deoxyribonucleic acid (DNA) can be separated by electrophoresis by using agarose or polyacrylamide gels. In gel electrophoresis, the samples move towards the positive and negative electrodes in the electric field (Figure 13). The samples separate as it moves at various speeds because the samples differ in charge and size. Deoxyribonucleic acid (DNA) is negatively charged. It therefore moves towards the positive electrode. Each sample's movement in the gel

was inversely proportional to the log of its molecular mass. This suggests that when a sample has a small molecular weight, it moves faster through the gel. The rate of migration was also determined by gel density. If the gel was of a high concentration, it will provide a better resolution for small fragments. This will then be the opposite for large fragments (Willey et al., 2008).

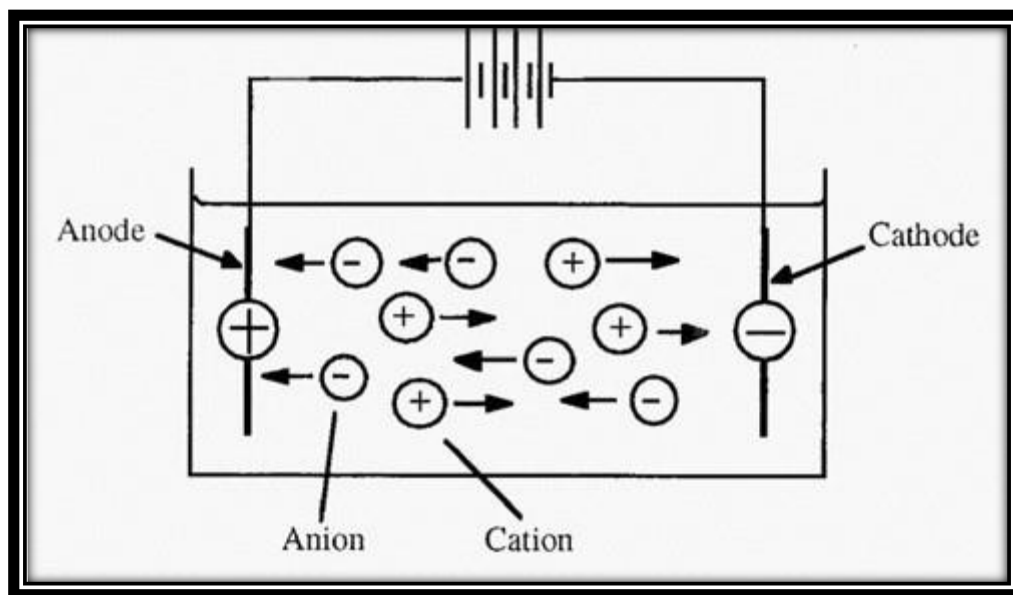

Figure 13: A diagram illustrating the movement of ions in electrophoresis (Dennison, 2002).

## Method

A 1.8 % gel was made for running of the gel. A voltage of 120V for 30 min was used. This was then viewed using the ALLIANCE 2.7 system. Once the gel was viewed, it could be determined which primers were specific for that particular DNA and to decide on which primer concentration was best to use. Once this was decided on, the PCR could be done.

## **Polymerase chain reaction (PCR) and electrophoresis**

Polymerase chain reaction (PCR) was invented by Kary Mullis, in the 1980. In 1994, he was awarded the Nobel Prize. Specific DNA fragments were amplified by PCR which makes use of a DNA-polymerase enzyme. The enzyme was involved in the amplification of the DNA. The DNA polymerase produced a complementary strand of DNA. A primer was bound to the 5' end of the DNA fragment which started the replication process. There were 2 primers involved in the replication process which only synthesizes a specific region of the DNA which results in billions of copies of DNA. Polymerase chain reaction (PCR) has many advantages in gene analysis, identification of viral, bacterial and fungal pathogens and in diagnosis of hereditary diseases. Polymerase chain reaction (PCR) can also be used in the cloning of DNA. This application can be used in the analysis of gene expression and as a useful tool in forensic medicine (Valones et al., 2009).

### **Method**

The best primer concentration was used with the volumes mentioned above in the PCR optimization. The DNA was then amplified with the thermocycling conditions mentioned above. A gel of 1.8% concentration was made and the gel was left to run for 1 h. This was to allow the molecular weight marker to separate. The molecular weight marker, GeneRuler 1Kb DNA ladder, was used to determine the size of the DNA fragment. This was then compared to the molecular size of the actual DNA fragment to determine if the correct bacteria were isolated.

## **Production of Secondary metabolites**

### **Method**

Bacteria were grown according to Mi, Niyaz Ahmed (2012) with some modifications. The bacteria were grown in tryptone soya broth with 2% NaCl in conical flasks. They were shaken for 3 days on a shaking incubator at 180 rpm.

## **Extraction of secondary metabolites**

### **Method**

The extraction was done according to (MI, 2012), but with a few modifications. The broth was transferred to 50 ml conical tubes and centrifuged at 3000 rpm for 10 min. The supernatant was transferred to conical flasks. The supernatant was then poured in a separating funnel. Ethyl acetate was added which was of equal volume as the supernatant. The mixture was shaken for 15 min and then left to settle for a further 15 min. This formed 2 layers, of which the top layer contains the secondary metabolites. This layer was then collected and the steps above were repeated. After the second extraction of each sample, the top layer was collected in a glass vials. The dried samples were then used for the treatment of the Hep G2 cells and the various assays were then performed thereafter.

## **Culturing of HepG2 Cells**

### **Method**

Hep G2 cells were grown in Eagle's minimal essential media (EMEM). This media was then supplemented with 50 µl of fetal calf serum, 5 ml of glutamine and 5 ml of antibiotic. These cells were grown at 37°C with 5% CO<sub>2</sub> level until confluent for the different assays.

### **Cell viability assay (MTT assay)**

The 3-[4,5- dimethylthiazol-2-yl]-2,5 diphenyl tetrazolium (MTT) determines the amount of viable cells in 96 well plates without performing complicated cell counting. This assay has frequently been used to ascertain the cytotoxicity of drugs at various concentrations. The principal of the assay suggests that viable cells have uniform mitochondrial activity. When an increase or decrease in the mitochondrial activity is noted, this indicates the number of cells that are viable. The mitochondria activity was indicated by the conversion of tetrazolium salt, MTT, into formazan crystals. The crystals were solubilised for homogenous measurement. Therefore the amount of viable cells can be determined by measuring the formazan concentration which was shown by optical density (OD). The OD was obtained on a plate reader at wavelength of 570 nm with a reference wavelength at 690 nm. When performing drug sensitivity tests, the OD values of the cells exposed to the drug was compared to the control cells (i.e. cells were not exposed to the drugs).

The MTT assay can be used on both primary cell lines and well-known cell lines for the testing of drug sensitivity. For dividing cells, the reduction of cell viability indicates cell growth inhibition. The drug sensitivity is then stated as the “concentration of the drug that is required to achieve 50% growth inhibition as compared to the growth of the untreated control (50% inhibitory concentration,  $IC_{50}$ )”. For non-dividing cells, drug sensitivity is indicated by the cell death of treated cells with reference to the reduction of cells seen in the control (50% lethal concentration,  $LC_{50}$ ). For acute myeloid leukaemia cells, the median cell survival of the control is 100%, this is not a problem since the results of the control is compared to the cells that have been exposed to the drug (van Meerloo et al., 2011).

## **Method**

Cells were plated in 96 well plates. After overnight adherence, the cells were treated with their respective treatment (24 h treatments). After 24 h, the supernatant was collected in eppendorf tubes for further assays. Thereafter, 120  $\mu$ l of MTT salt was then added to the wells. The MTT salt was made freshly on the day of the assay. The plate was then incubated for 4 h. After 4 h, the MTT was removed and 100  $\mu$ l of DMSO was added to the wells. This was then incubated for 1h. The absorbance was then determined at a wavelength of 570 nm using a plate reader.



## **Flow cytometry and Luminometry**

### **Adenosine triphosphate (ATP) assay**

The CellTiter-Glo Luminescent Cell Viability Assay is a homogeneous assay that detects the amount of ATP which indicates the number of viable cells and also suggests that there are metabolically functioning cells present. This ATP assay can be used for automated high-throughput screening, cytotoxicity and cell proliferation procedures. The CellTiter-Glo substrate and CellTiter-Glo buffer added together make up CellTiter-Glo reagent. The reagent was then added to the cells (Figure 14). Like the caspase assays, the ATP assay requires no washing of cells, removing of media or the many pipetting steps. The reagent causes the cells to lyse, which then generates luminescence. The luminescence is proportional to the quantity of ATP which is proportional to the number of viable cells. This assay also makes use of the thermostable enzyme, luciferase. The enzyme allows for a stable luminescent signal to be produced. The half-life of the signal produced is more than 5 hours. This assay offers flexibility and requires no replenishment of the reagent. As the ATP assay doesn't require many pipetting steps this reduces the errors that may occur like with other ATP assays (Promega CellTiter-Glo® Luminescent Cell Viability Assay, Technical Bulletin No. 288).

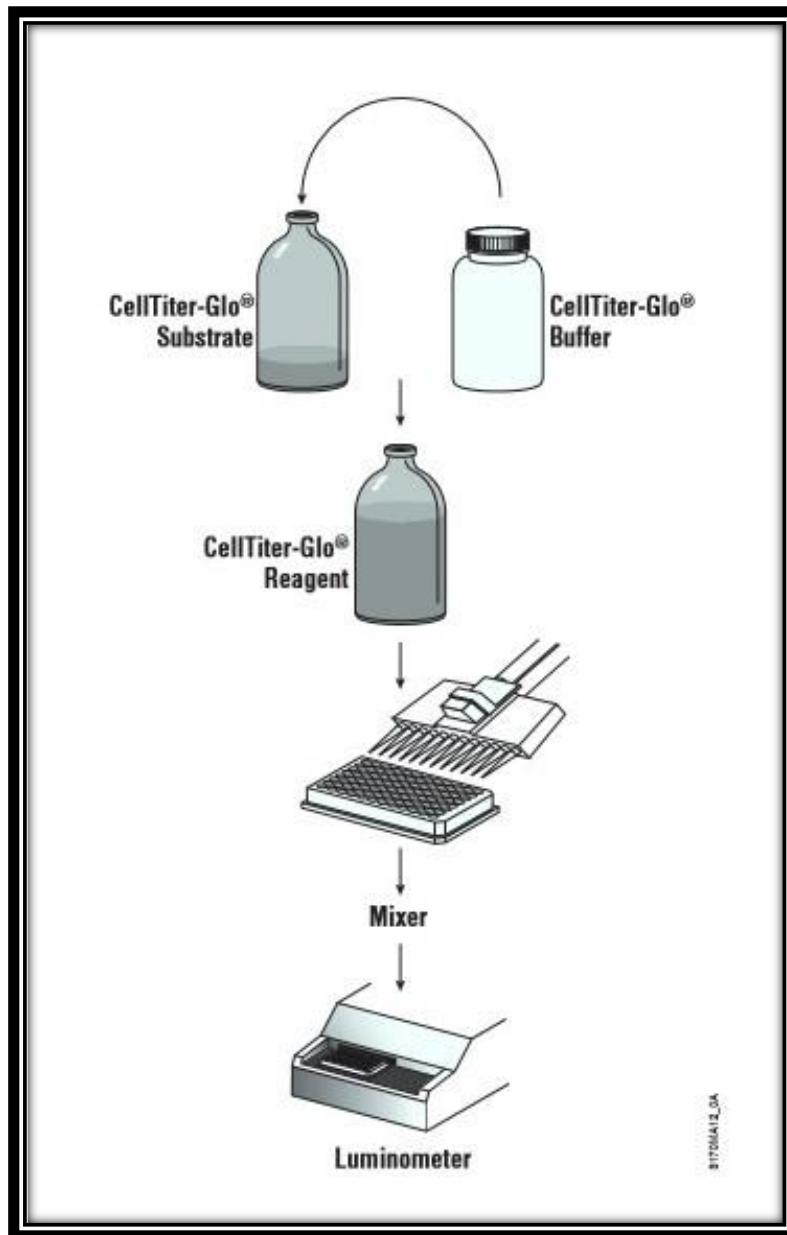

Figure 14: An illustration depicting the process of ATP assay using the CellTiter-Glo® Assay Reagent (Source: Promega CellTiter-Glo® Luminescent Cell Viability Assay, Technical Bulletin No. 288).

## **Mitochondrial depolarization**

Mitochondria are responsible for producing ATP as fuel for eukaryotic cells. ATP is produced when ADP binds to inorganic phosphate (Pi) by oxidative phosphorylation. During the production of ATP, the inner membrane of the mitochondria becomes electrically charged. This is referred to as mitochondria trans-membrane potential ( $\Delta\Psi_m$ ). This charge offers the essential energy needed for ATP synthesis. The mitochondrial transmembrane potential is a complicated process that is assisted by the electron transport chain. The electron transport chain is made up of protein complexes that transport electrons and pump protons through the inner membrane (Figure 15). The mitochondrial membrane becomes negatively charged and is referred to as the membrane potential ( $\Delta\Psi$ ) across the mitochondrial (m). The mitochondria is then described as a polarised mitochondria. Cytochrome c performs a role in the electron transport chain by transporting electrons from complex 3 to complex 4. When apoptosis of the cells occur, cytochrome c is released and this prevents the transporting of electrons. The end result is that there is a rapid loss of  $\Delta\Psi_m$  shortly after cytochrome c being released. The mitochondria is now described as depolarised mitochondria. With the loss of  $\Delta\Psi_m$ , there is mitochondria depolarisation and mitochondrial outer membrane permeabilisation (MOMP). These are linked to one another. Cationic dyes can be used to measure the  $\Delta\Psi_m$ . Dyes include Mitotracker, 5,5',6,6'-tetrachloro-1,1',3,3'-tetra-ethylbenzimidazole carbayanine iodide (JC-1) etc. (Christensen et al., 2013).

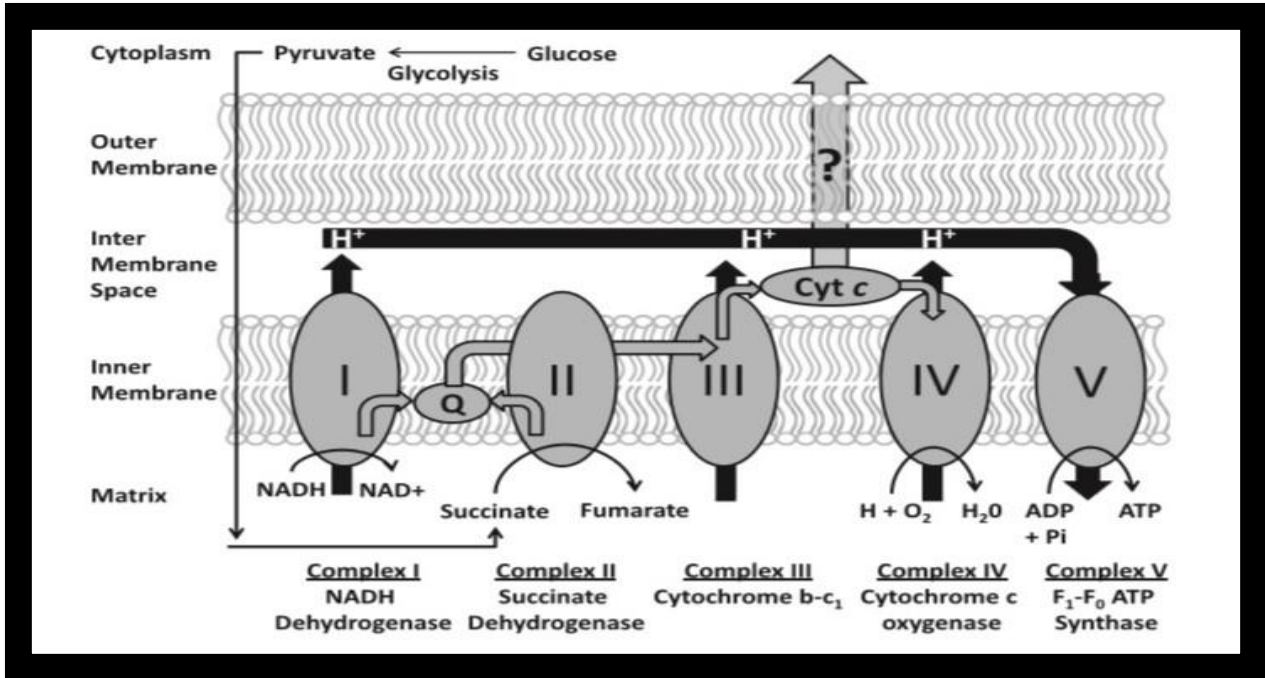

Figure 15: The electron transport chain and membrane potential across the mitochondria (Christensen et al., 2013).

**Apoptosis and Annexin V**

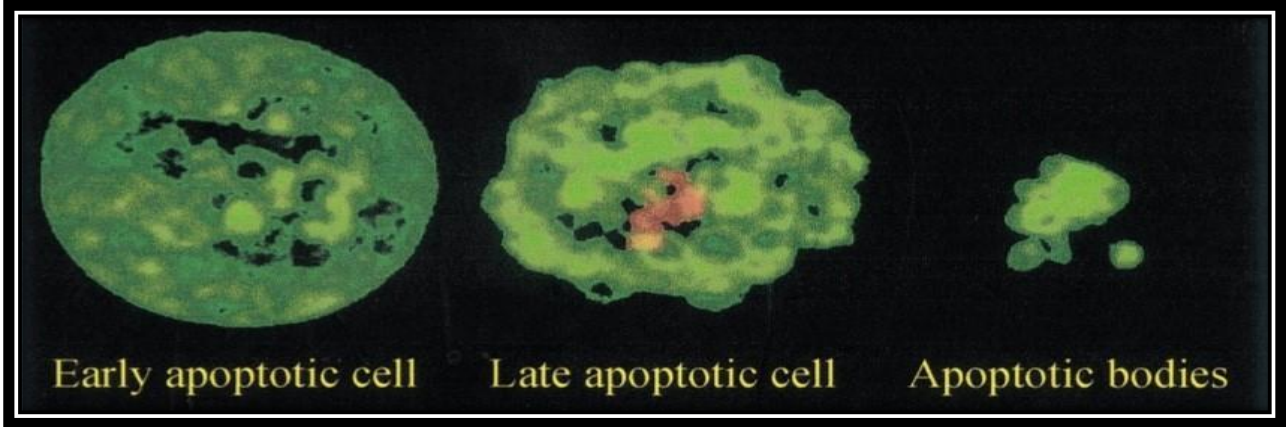

Figure 16: The various stages of apoptosis observed using Jurkat cells that were treated with anti-Fas and was incubated with V-Oregon Green and PI (Vermes et al., 2000).

Cell death is a normal process in the development of multicellular organisms or during the immune response. Apoptosis can be triggered by toxins, chemicals, physical/xenobiotic agents such as radiation, heavy metals and heat and in response to unfavourable conditions (Samali et al., 1999).

There are distinct morphological and biochemical changes associated with apoptosis (Figure 16). These are: cells shrinkage, chromatin condensation, cell surface changes, membrane blebbing and DNA fragmentation. Deoxyribonucleic acid (DNA) fragmentation is the delayed event of apoptosis which there are many procedures to measure it. Determining early apoptosis is important for the investigation of the central pathway resulting in apoptosis. There is a technique to identify early apoptosis. A phospholipid, phosphatidylserine (PS), moves to the cell surface during apoptosis. This applies for many cell lines and for many apoptotic stimuli. When the PS is visible to the outside cell surface, it makes the apoptotic cell to be easily distinguished by macrophages/ neighbouring cells. The macrophages assist the non-inflammable exclusion of dying cells by phagocytosis.

Once phosphatidylserine is exposed on the cell surface, it can be identified by the binding of fluorescence isothiocyanate (FITC) – labelled Annexin V. Annexin V is a protein that belongs to a group of phospholipid-binding proteins that binds only to negatively charged phospholipids, like PS. This interaction occurs in the presence of calcium, cells that are FITC-labelled Annexin-V positive are identified by fluorescence microscopy and flow cytometry. Annexin-V labelling can be used with propidium iodide and Hoechst 33342. This depicts the developing stages of

apoptosis. The PS exposure on the cell surface, mainly happens before plasma membrane permeabilization, DNA condensation and membrane blebbing, making PS translocation a useful and quick method for detecting of early apoptosis (Bossy-Wetzel and Green, 2000).

Apoptosis is programmed cell death. The cell has machinery that triggers the cell death and its removal (Lin et al., 2005). When the cells die, the PS is exposed on the cell surface. This happens in the early stages of apoptosis and the cell membrane remains undamaged. However, for necrosis, the cell membrane is damaged and cellular components leak into the surrounding environment. The measuring of Annexin-V binding in combination with a dye exclusion test makes for a useful assay in identifying apoptotic cells as well as to distinguish between necrosis and apoptosis. Intact cells are FITC<sup>-</sup> and PI<sup>-</sup>, apoptotic cells are FITC<sup>+</sup> and PI<sup>-</sup> and necrotic cells are both FITC<sup>+</sup> and PI<sup>+</sup> (Vermes et al., 1995).

### **Caspase 8**

The Caspase-Glo 8 assay is a homogeneous luminescent assay that was created to measure the activity of caspase-8 activity (Figure 17B). This caspase participate in the initiation of the extrinsic/receptor-mediated apoptotic pathway in mammalian cells. A caspase-8 substrate was added to a buffer system which is needed for detecting caspase activity, cell lysis and luciferase activity. Caspase-Glo 8 can be used for automated high-throughput screening of caspase 8 activity (Figure 18). Beckman Coulter Biomek 2000 and Biomek FX Automation Workstation are used for 96 and 384 well plates. This assay offers a quick, sensitive and flexible detection of

caspase-8 activity. This kit can be used with purified enzymes and cultured cells (Promega Caspase-Glo 8 assay).

### **Caspase 9**

The Caspase-Glo 9 assay is a homogenous luminescent assay that was developed to measure the activity of caspase 9 activity (Figure 17C). This caspase participates in the initiation of the intrinsic pathway of mammalian cells. Similar to the Caspase-Glo 8 assay, it can be used in automated high-throughput screening for caspase-9 activity (Figure 19). Beckman Coulter Biomek 2000 and Biomek FX Automation Workstation are also used for 96 and 384 well plates. This assay can also be used with purified and cultured cells. This assay has an inhibitor known as protease inhibitor which decreases the non-specific background in the assay which therefore better the accuracy of the data (Promega Caspase- Glo® 9 Assay, Technical Bulletin).

### **Caspases 3/7**

The Caspase-Glo assay is a homogenous luminescent assay that was created to measure the activity of Caspase-3 and Caspase-7. This caspase participate in the process of apoptosis in mammalian cells. A substance which was made up of tetrapeptide chain, DEVD, was responsible for producing luminescence which has been optimized for cell lysis, caspase activity and luciferase activity. When the Caspase-Glo 3/7 chemicals was added, it caused the cells to lyse, followed by caspase cleavage of the substrate which resulted in the production of luminescence (Figure 17A). Luciferase was the enzyme that causes the luminescent signal. The luminescence

produced was proportional to the caspase activity of the cells. The Caspase – Glo 3/7 chemicals was dependent on the enzyme, luciferase, which was capable of producing a stable luminescent signal and improves the functioning of the assay for various conditions.

The assay can be used for automated high-throughput screening of caspase activity/apoptosis (Figure 18). The assay can be used for 96, 384 and 1536 well plates. Steps such as cell washing, the removal of media and the several pipetting steps are not essential. Both activities of the caspase and luciferase enzymes achieves stability, so the signal reaches its maximum in an hour and can remain stable for many hours. This feature makes this assay a sensitive, rapid and flexible caspase-3/7 activity assay. The assay is compatible with purified enzymes, adherent and cells in suspension. The Caspase-Glo 3/7 assay can be used for cell lines such as Hep G2, HeLa, Jurkat etc. The cell lines tested have been exposed to various drugs and stimulants of apoptosis. The assay may be used with other homogeneous assays to measure many different parameters (Promega Caspase-Glo® 3/7 Assay, Technical Bulletin). The Caspase-Glo 8 assay and Caspase-Glo 9 assay have similar features as mentioned above for Caspase-Glo 3/7 assay.



A)

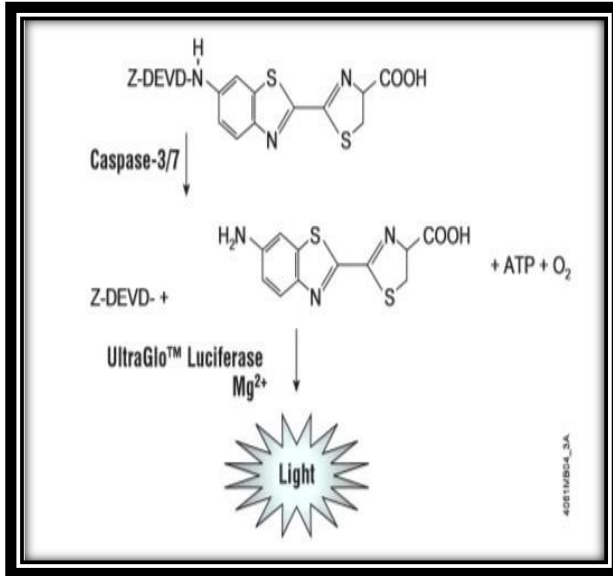

B)

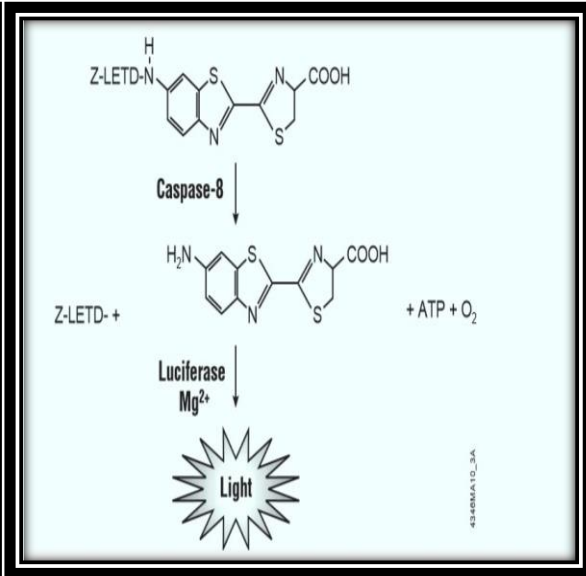

C)

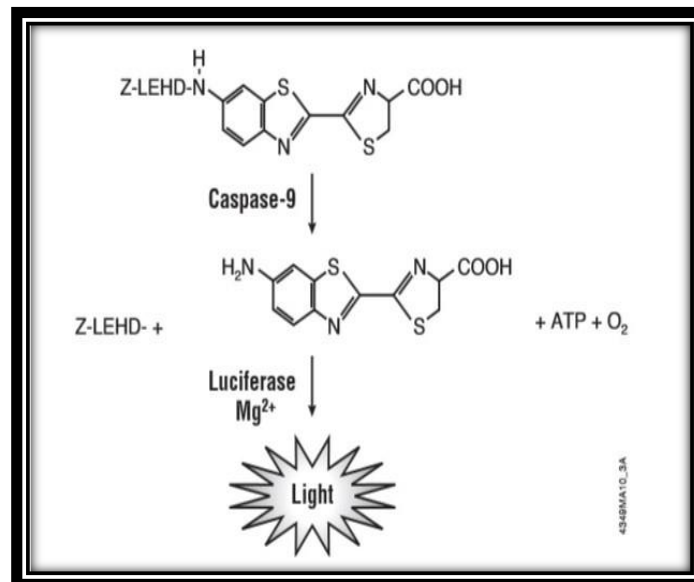

Figure 17: Caspase 3/7 cleaves the luminogenic substrate that comprises of DEVD. Amino-luciferin is then liberated to cause the luciferase reaction and emit light (A) (Promega Caspase-Glo® 3/7 Assay,

Technical Bulletin). Caspase 8 cleaves the luminogenic substrate that comprises of LETD. Amino-luciferin is then liberated to cause the luciferase reaction and emit light (B) (Promega Caspase-Glo® 8 Assay, Technical Bulletin). Caspase 9 cleaves the luminogenic substrate that comprises of LEHD. Amino-luciferin is then liberated to cause the luciferase reaction and emit light (C) (Promega Caspase-Glo® 9 Assay, Technical Bulletin).

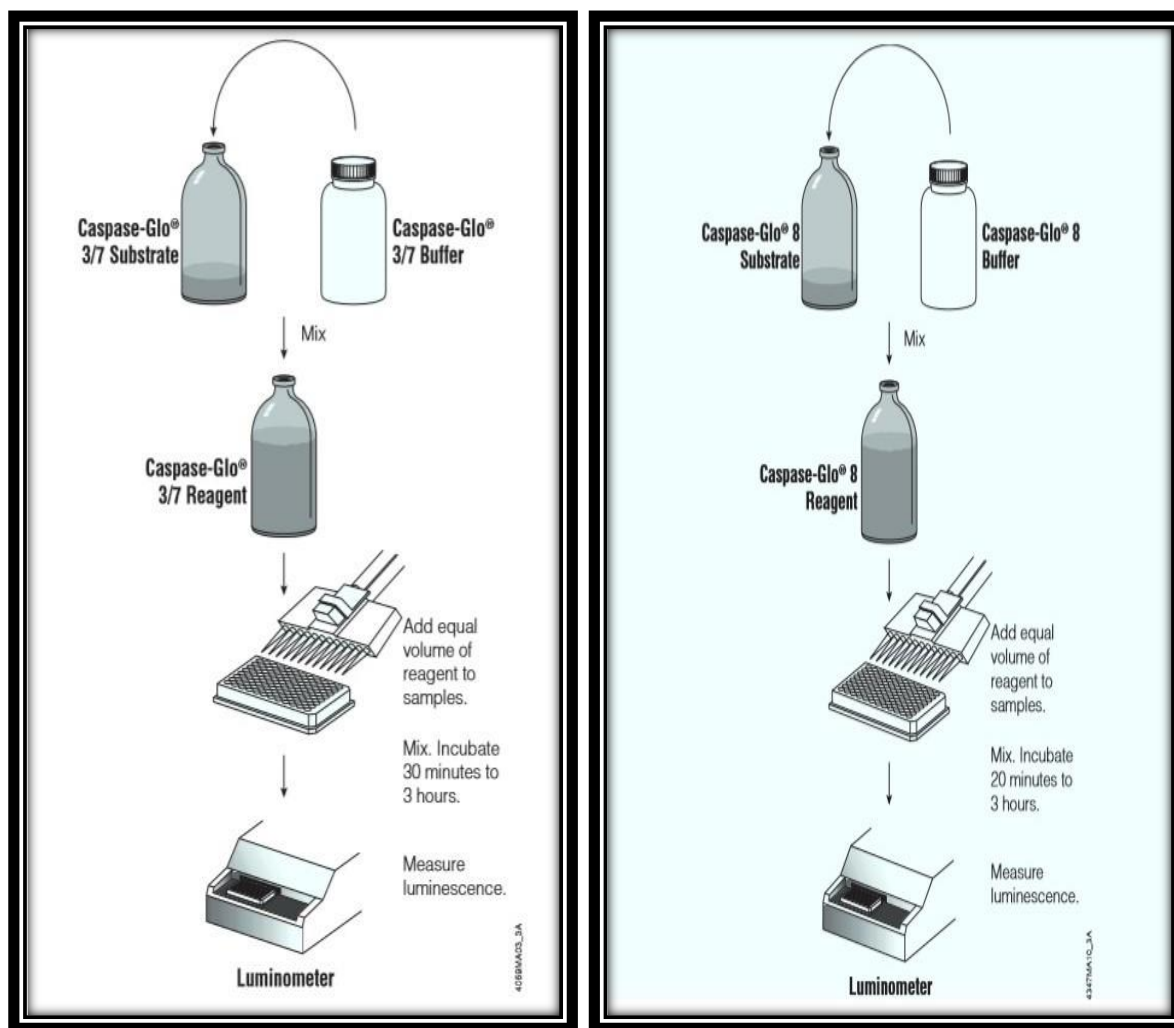

Figure 18: Illustrations depicting the process of Caspase-Glo 3/7 and Caspase-Glo 8 assays using the Caspase- Glo® 3/7 Reagent and Caspase- Glo® 8 Reagent respectively (Promega Caspase-Glo® 3/7 Assay, Technical Bulletin, Promega Caspase-Glo® 8 Assay, Technical Bulletin).

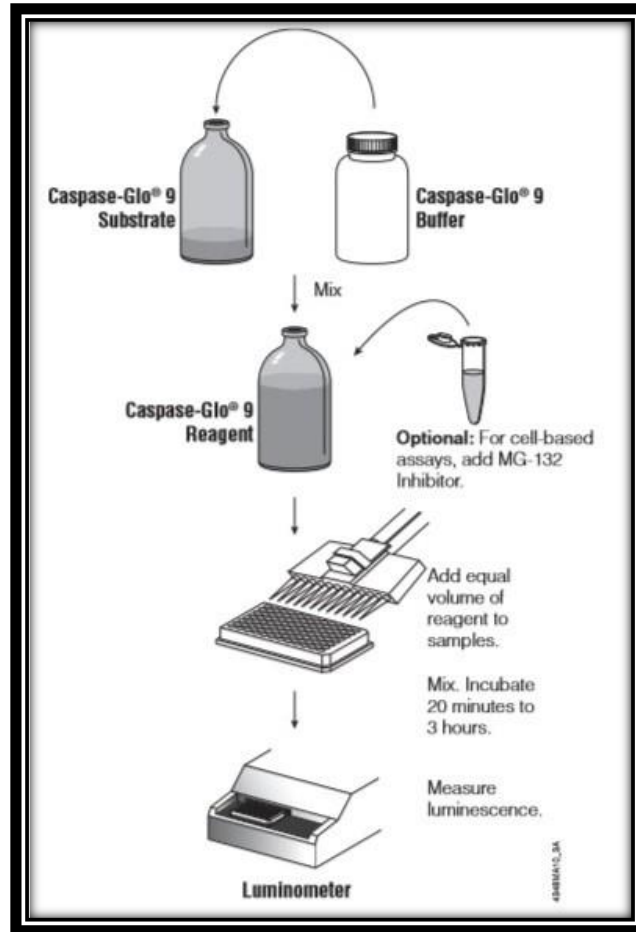

Figure 19: An illustration depicting the process of Caspase-Glo 9 assay using the Caspase- Glo® 9 Reagent (Source: Promega Caspase-Glo® 9 Assay, Technical Bulletin).

### Preparation for Assays

Cells were treated for 24 h. After 24 h, the cells were washed with PBS. Then 1 ml of trypsin was added to each flask. The cells were then counted. For the ATP assay, Caspase 3/7, 8 and 9 assays, 20000 cells were needed for each well. This was then done in triplicate. For Annexin V and mitochondrial polarisation, 200000 cells were needed for each well. This was done in triplicate. The cells were then spun down to remove the CCM. A volume of 750 µl of PBS was

added to ATP and caspase tubes while 600  $\mu$ l were added to the annexin V and mitochondrial depolarisation tubes.

## **Method**

For the ATP assay, a volume of 50  $\mu$ l of CellTiter Glo Reagent was added to 50  $\mu$ l of cell culture in a 96 well plate. The plate was shaken on a plate shaker for 2 min to induce cell lysis. The plate was incubated for 10 min at room temperature to stabilize the luminescence signal. The plate was then placed in a luminometer and the RLU values were determined (Promega technical Bulletin CellTiter-Glo® Luminescent Cell Viability Assay).

For the mitochondrial depolarisation assay, cells were centrifuged at 400 x g for 5 min to remove PBS. A volume of 0.5 ml of JC-1 working solution was added to each sample. This was incubated for 10-15 min at a temperature of 37°C with a supply of 5% CO<sub>2</sub>. After 10-15 min, each sample was washed with 2 ml of 1X Assay buffer at room temperature, thereafter with 1 ml of 1X Assay buffer at room temperature. Each sample was then re-suspended in 0.5 ml of 1X Assay buffer. A volume of 50  $\mu$ l was pipetted in a 96 well plate and read by a flow cytometer (BD™ MitoScreen Flow Cytometry Mitochondrial Membrane Potential Detection Kit Instruction Manual).

For the Annexin V assay, cells were centrifuged at 200 x g for 5 min to remove the PBS. The cells were re-suspended in Annexin V-FLUOS labelling solution and 50  $\mu$ l was pipetted in a 96

well plate and was left for 10-15 min at a temperature of 15-25 °C. The plate was read with a flow cytometer (Roche, Annexin V-FLUOS Staining Kit information Sheet).

A volume of 50 µl of Caspase-Glo 3/7, 8 or 9 reagents was added to 50 µl of cell culture in a 96 well plate. The plate was shaken on a plate shaker for 30 sec at 300-500 rpm. The plate was incubated for 30 min at room temperature. The plate was then placed in the luminometer and the RLU values were determined (Promega Technical Bulletin Caspase-Glo 3/7 Assay, Promega Technical Bulletin Caspase-Glo 8 Assay, Promega Technical Bulletin Caspase-Glo 9 Assay).

### **Comet assay**

Single-cell gel electrophoresis, also known as comet assay, is an assay for determining the DNA strand break of eukaryotic cells. Cells are fixed in agarose on a microscope slide. The cells are lysed with detergent and a high concentration of salt. This causes nucleoids, comprising of supercoiled loops of DNA which are linked to the nuclear matrix. Comets were formed when electrophoresis takes place at high pH. Comets can be viewed using a fluorescent microscope. The intensity of the comet tail to the head indicates the total of DNA breaks. DNA loops that were nicked will lose its supercoil confirmation and be free to lengthen itself towards the anode. The comet assay can be used for analysis of DNA damage and repair, human bio-monitoring, molecular epidemiology and assessing the effect chemicals for genotoxicity (Collins, 2004)

## **Method**

Cells were treated for 24 h and then trypsinized and collected. For each treatment, 3 slides were done. The slides for the comet assay were made using 1% and 2% LMPA. Each slide had a cell suspension of 20 000 cells. The slides were left in cell lysis buffer for 1 h. It was then removed and placed in the electrophoresis tank with tank buffer and left to equilibrate for 20 min. After 20 min, the slides were left to run for 35 min at 120V. The slides were washed three times with neutralisation solution for a period of 5 min each. The slides were then stored on moist paper and viewed the next day.

## **Thiobarbituric acid reactive substances (TBARS)**

Malondialdehyde is used for detecting oxidative stress. Malondialdehyde is the end product of free radical attack. The reaction of malondialdehyde and 2-thiobarbituric acid (TBA) is a common assessment of oxidative stress. The end product, which is 2-thiobarbituric acid reactive substances (TBARS), is critiqued negatively, since MDA is included in TBARS. The MDA is generated by autoxidation under assay conditions but also cross-reactivity with non-MDA molecules. Therefore it is necessary to validate the usefulness of the TBARS assay when measuring oxidative stress on different cells/tissues (Oakes and Van Der Kraak, 2003).

For the TBARS assay, peroxidised lipids were heated with the chemical, TBA, in an acidic medium. Malondialdehyde (MDA) will thereafter react with the TBA to generate a red coloured complex. This complex has a maximum absorption at a wavelength of 532 nm. The intensity of

the red coloured complex can be used to determine the oxidation of the heated lipids (Setiowaty and Che Man, 2003).

## **Method**

The supernatant collected from the treated cells were used for this assay. A volume of 400  $\mu$ l of each treatment was pipetted in glass tubes. For the positive and negative control, 500  $\mu$ l of 2 %  $H_3PO_4$  and 400 $\mu$ l of CCM were added respectively. Then 200  $\mu$ l of 7%  $H_3PO_4$  were added to each tube. Then a volume of 400  $\mu$ l of TBA/BHT solution was added to each tube except the blank. A volume of 400  $\mu$ l of 3mM of HCL was added to the blank instead. All tubes were vortexed. The pH of the tubes was adjusted to 1.5 using HCL. A volume of 1 $\mu$ l of MDA was added to the positive control. The tubes were then boiled in a water bath for 15 min. After the test tubes cooled, 1.5 ml of butanol was added to all test tubes. The test tubes were left to settle and 500  $\mu$ l of the upper layer was collected in eppendorf tubes. The eppendorf tubes were then centrifuged at 13200 rpm for 6 min at 24  $^{\circ}$ C. Then 100  $\mu$ l were pipetted in a 96 well plate and read at a wavelength of 532 nm with a reference of 600 nm.

## **Statistical analysis and primers**

All statistical analysis was done with GraphPad Prism software package (GraphPad Software Inc.). All primers were ordered from Inqaba Biotechnical Industries (Pty) Ltd.

## Chapter 3 - Results

### **The testing of secondary metabolites for antibacterial activity on nutrient agar**

The secondary metabolites of *B. cereus* and *V. alginolyticus* were tested to determine if there was any antibacterial activity. Nutrient agar was used as the media and ceftrizoxine (30 µg) as the antibiotic. *S. aureus* ATCC 25923, *E. coli* ATCC 25922 and *P. aeruginosa* ATCC 27853 were the strains used to inoculate the nutrient agar. There were concentration factors of 1X, 5X, 10, 20X and 50X that were tested. There was no antibacterial activity for both extracts at the different concentration factors. All zone of inhibition produced by the reference strains were according to the standard stated in “Performance Standards for Antimicrobial Susceptibility Testing” (CLSI. Performance Standards for Antimicrobial Susceptibility Testing: Nineteenth Information Supplement. CLSI document M100-S19. Wayne, PA: Clinical and Laboratory Standards Institute, 2009). PBS was used as a negative control for all nutrient agar plates and no zone of inhibition was produced (Figure 20).



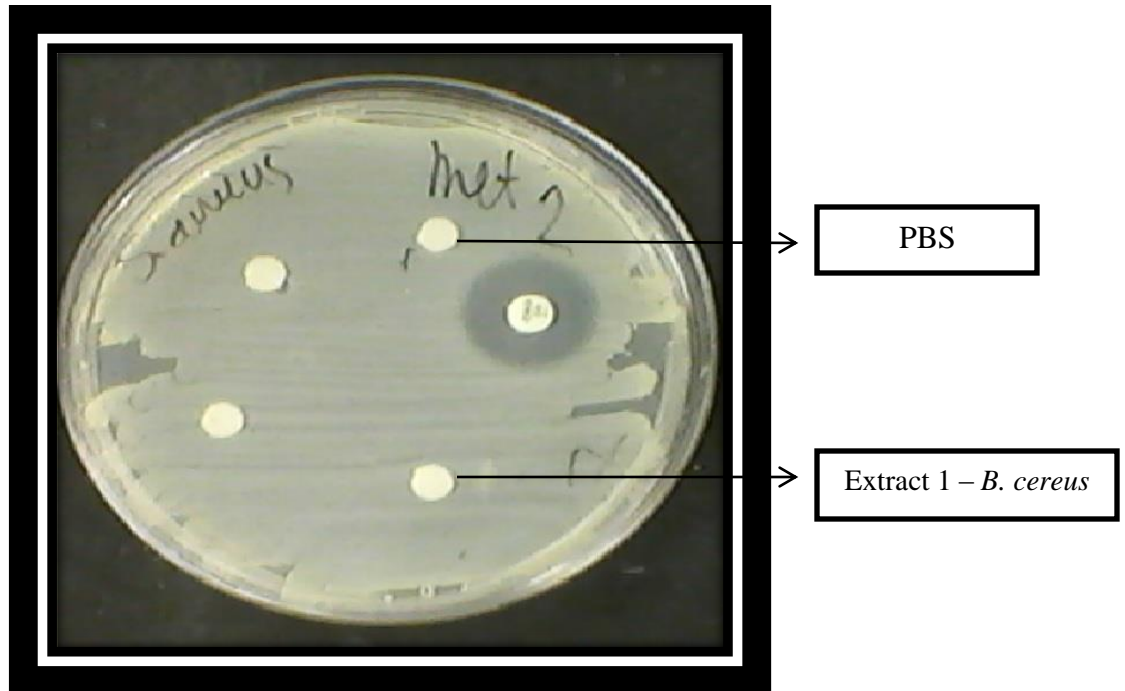

Figure 20: Testing of the crude extracts from *B. cereus* against *Staphylococcus aureus* ATCC 25923 using the zone of inhibition method to determine if the extracts had any antibacterial activity (Pictures supplied by author).

### **DNA extraction from bacteria**

DNA was extracted from 2 bacterial strains using the method mentioned in the DNA extraction section. A NanoDrop spectrophotometer was then used to measure the DNA concentration and DNA quality. All bacterial DNA ratios ( $A_{260}/A_{280}$ ) were 1.8. The DNA was therefore of a pure quality and therefore could be used for polymerase chain reaction.

### Polymerase Chain Reaction (PCR) of *B. cereus* and *V. alginolyticus*

The DNA of two bacterial strains was tested using primers stated in table 7 to confirm the presence of *B. cereus* and *V. alginolyticus*. The GeneRuler 1Kb molecular weight marker was used. The size of *V. alginolyticus* and *B. cereus* were 737 bp and 1686 bp, respectively (Figure 21).

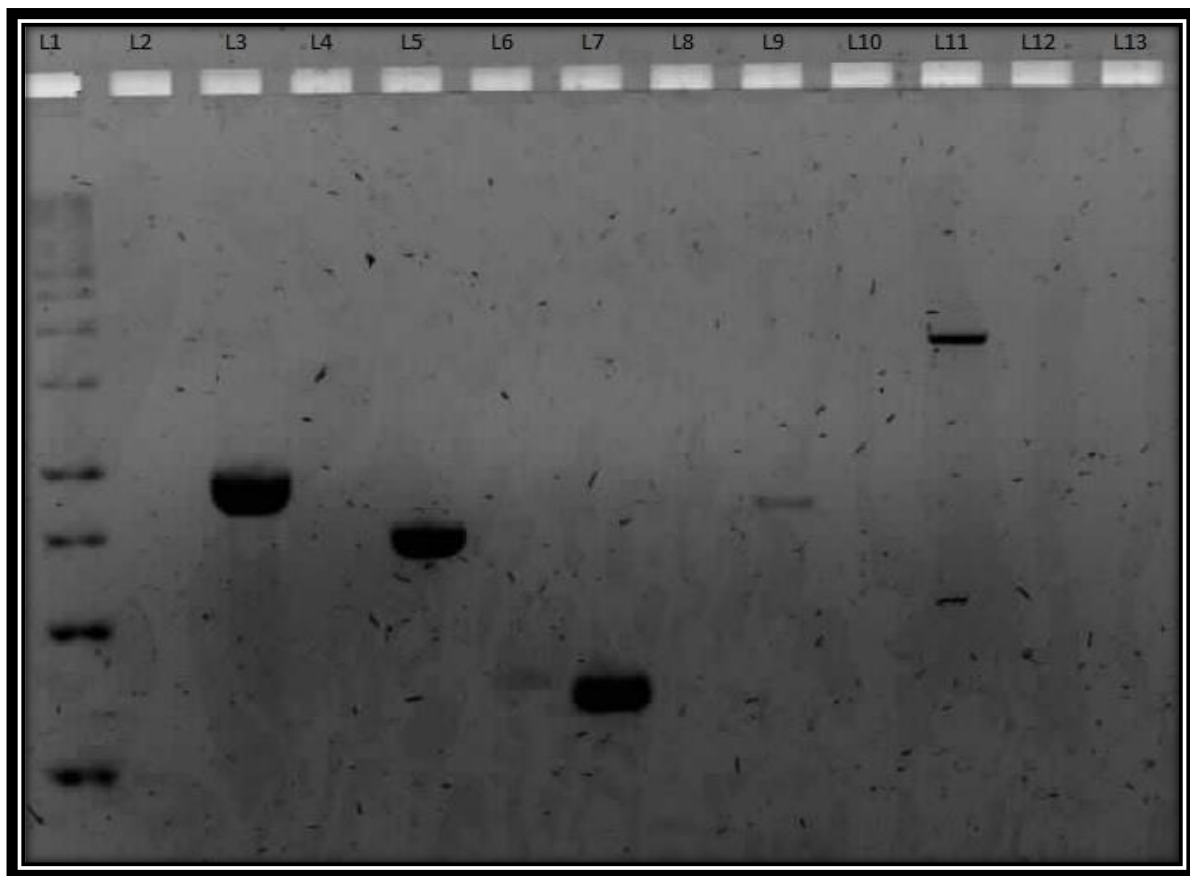
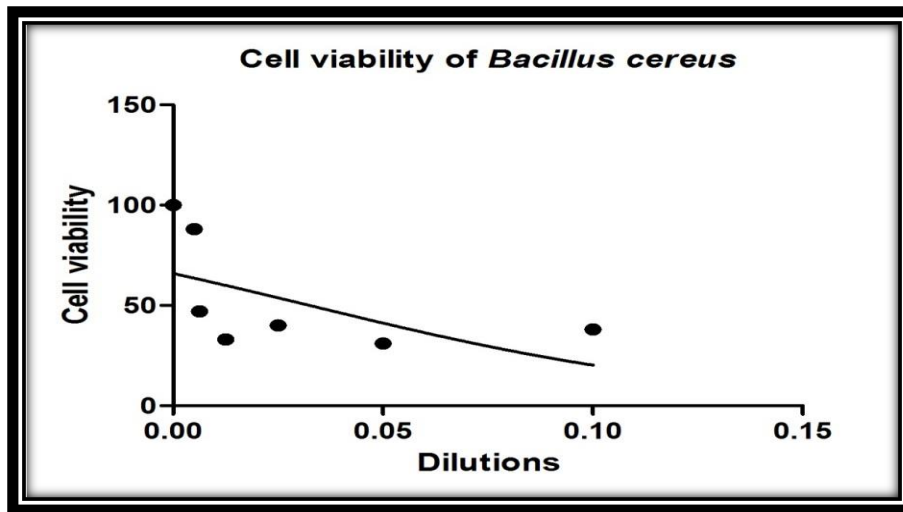

Figure 21: PCR and electrophoresis were done to confirm the identities of the 2 bacterial strains used. The electrophoresis confirmed it was indeed *B. cereus* and *V. alginolyticus* present. L1 is the GeneRuler molecular weight marker (1Kb). The DNA fragments of *V. alginolyticus* (L5) and *B. cereus* (L11). The sizes of the DNA fragments were as follows 737 bp and 1686 bp respectively (Picture supplied by author).

### Cell viability assay (MTT)

Hep G2 cells were treated with the extracts from *B. cereus* and *V. alginolyticus*. The cells were treated for a period of 24 hours. The cell viability was determined and the results are presented in figure 22 (A-B).

A)



B)

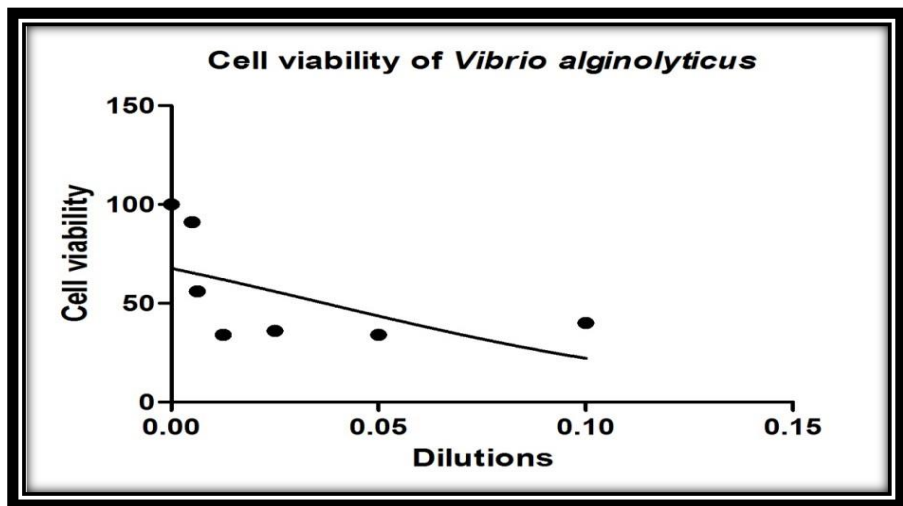

Figure 22 (A-B): Hep G2 cells were treated with the extracts from *B. cereus* and *V. alginolyticus*. The MTT assay showed a decrease in Hep G2 cell viability as the dilution decreases.

After analysis, the concentration required for 50 % cell death was determined to be 0.764 mg/ml and 0.918 mg/ml for *B. cereus* and *V. alginolyticus* respectively. For *B. cereus*, a lower concentration was needed to cause 50% cell death. This indicated that it was more potent than the *V. alginolyticus* extract.

Apoptosis was determined using flow cytometry in assays such as Annexin V and propidium staining. Luminometry was also used to determine the levels of ATP and determine the caspase activity. The ATP, mitochondrial depolarisation, caspases and comet assays as well as the Annexin V and propidium staining were analysed using the Kruskal-Wallis test.

### **Annexin V-FLUOS and Propidium Iodide (PI)**

The Annexin V and propidium iodide staining of Hep G2 cells were done to determine whether apoptosis and necrosis occurred, when the cells were individually treated with the 2 extracts (Figure 23 and 24).

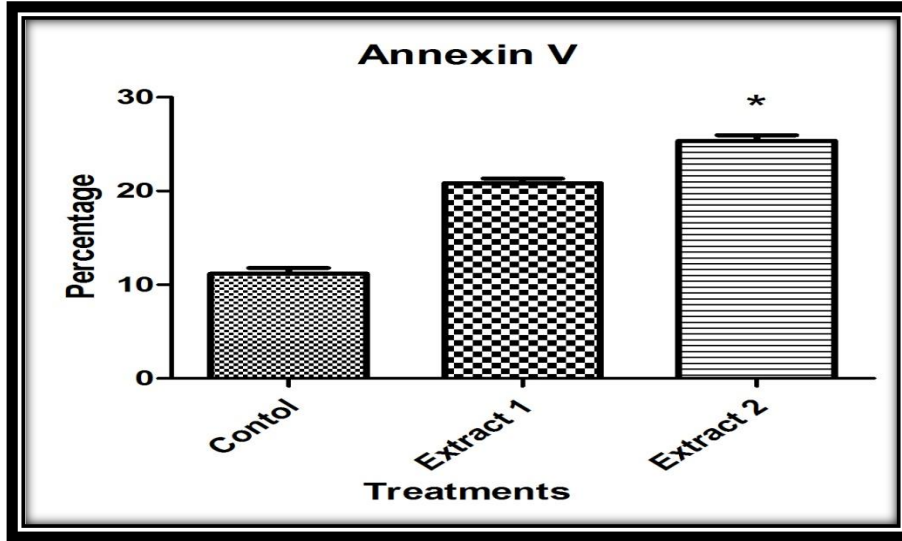

Figure 23: Hep G2 cells were treated with extract 1 (*B. cereus*) and extract 2 (*V. alginolyticus*) for 24 hours. After 24 hours, the Annexin V assay was used to determine early apoptosis. From the above results, the apoptosis caused by the extract from *B. cereus* extract was higher than the control. This however was not significant. On the other hand, apoptosis caused by the *V. alginolyticus* extract was significant when compared to the control.

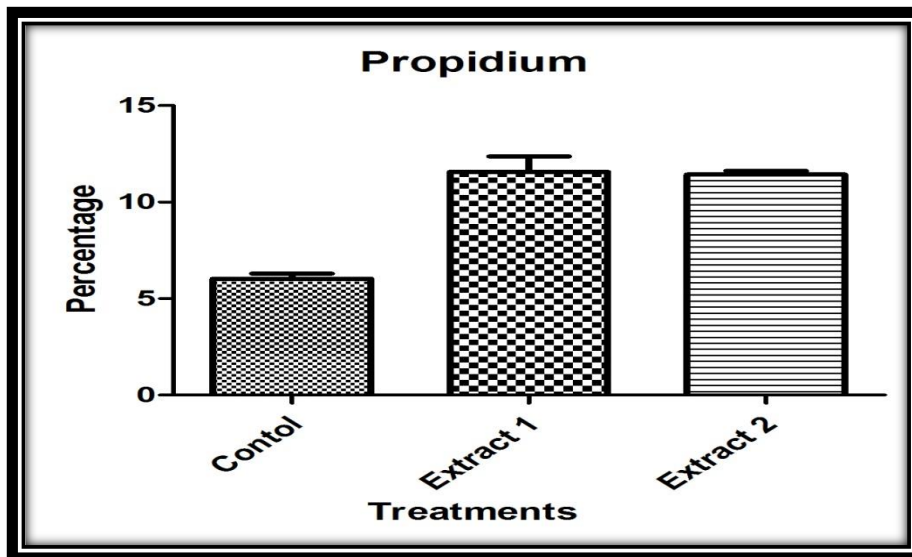

Figure 24: Extract 1 and 2 showed a higher propidium percentage than the control. There were no significance.

The figures above, show that after the Hep G2 cells were treated with the different extracts, there were an increase in Annexin V and propidium percentage when compared to the Hep G2 that were left untreated. These assays are known for determining early apoptosis/late apoptosis and necrosis. These higher percentages suggest that the treated Hep G2 underwent apoptosis and necrosis.

### Adenosine triphosphate (ATP) assay

Hep G2 cells were treated for 24 h and the ATP levels were determined using the Promega CellTiter-Glo® Luminescent Cell Viability Assay. The ATP levels of the extracts were compared to the ATP level of the control (Figure 25).

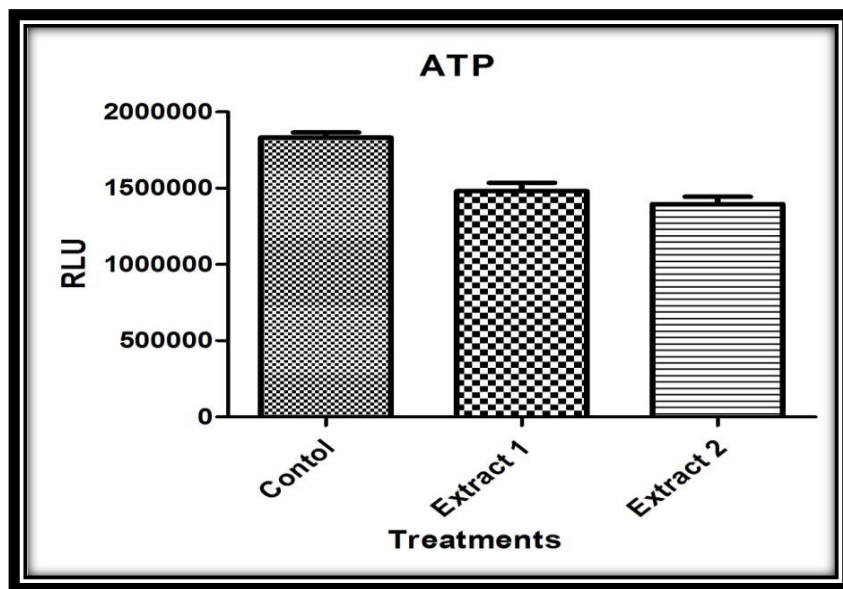

Figure 25: The ATP levels observed when Hep G2 cells were treated with extract 1 and 2 and the untreated cells. Extract 1 and 2 showed a decrease in ATP levels with reference to the control. There were no significance in the ATP levels determined.

## Mitochondrial depolarisation

Cells were treated individually with the extracts from *B. cereus* and *V. alginolyticus* and then used to determine the mitochondrial depolarisation of the extracts. The mitochondrial depolarisation of the cells treated with the extracts was compared to the control cells and are shown below (Figure 26).

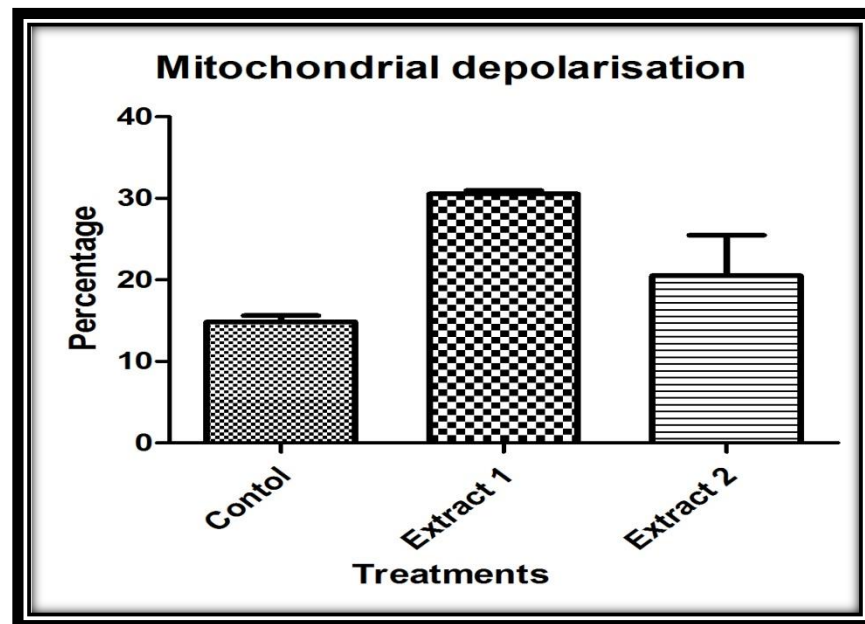

Figure 26: The effect of the *B. cereus* and *V. alginolyticus* extracts on Hep G2 cells after being treated for 24 hours. Here, the mitochondrial depolarisation was not significant when compared to the control. The cells exposed to the extracts had a higher mitochondrial depolarisation than the control cells. These results are re-emphasizing the results observed with ATP assay. Both assays showed that the cells' ATP levels were decreased and this can be observed when the cells are undergoing apoptosis.

### **Thiobarbituric acid reactive substances (TBARS)**

The supernatant of the Hep G2 cells that had been treated for 24 h had been collected. It was then used in the thiobarbituric acid reactive substances assay. The amount of MDA in the sample was calculated by the following calculation:  $(\text{Average optical density}/156\text{mM}) * 1000$ . The MDA concentration is shown in Table 8. The MDA concentration for control, extract 1, extracts 2, negative and positive samples were 0,137, 0,132, 0,150, 0,088 and 20,502 respectively.

Table 8: The mean of absorbance and the MDA concentrations obtained using the TBARS assay

<b>Treatment</b>	<b>Absorbance 1</b>	<b>Absorbance 2</b>	<b>Absorbance 3</b>	<b>Mean</b>	<b>MDA</b>
<b>Control</b>	0,02	0,022	0,022	0,021	0,137
<b>1</b>	0,019	0,021	0,022	0,021	0,132
<b>2</b>	0,022	0,024	0,024	0,023	0,150
<b>Negative</b>	0,015	0,013	0,013	0,014	0,088
<b>Positive</b>	3,145	3,221	3,229	3,198	20,502

### **Caspase Activity**

Treated Hep G2 cells were used to determine the caspase activity of the cells. The caspase 3/7, 8 and 9 activities were determined for the 2 extracts and are shown by figure 27 (A-C):



A)

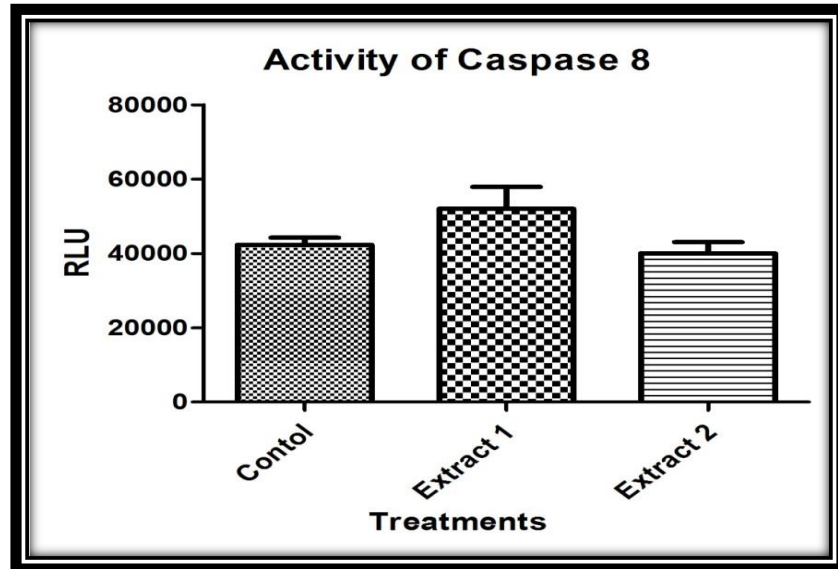

B)

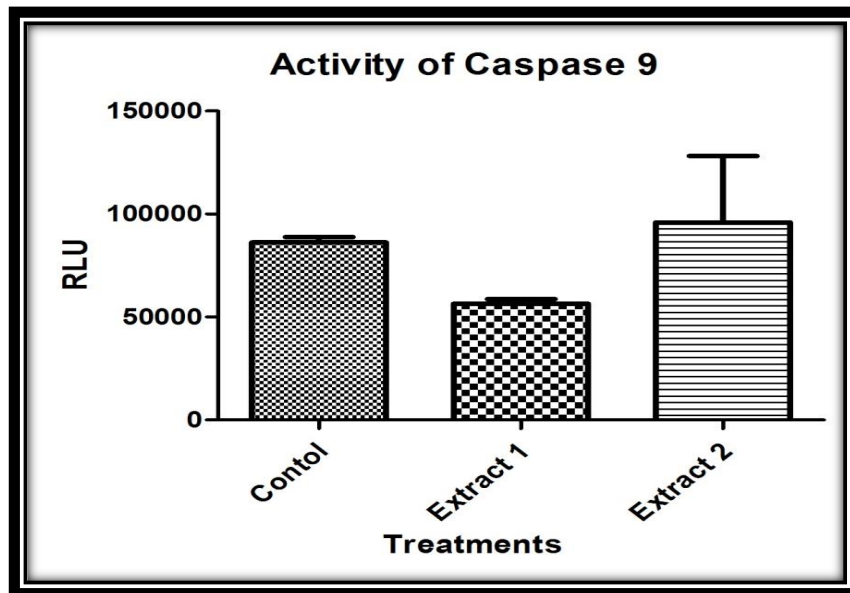

C)

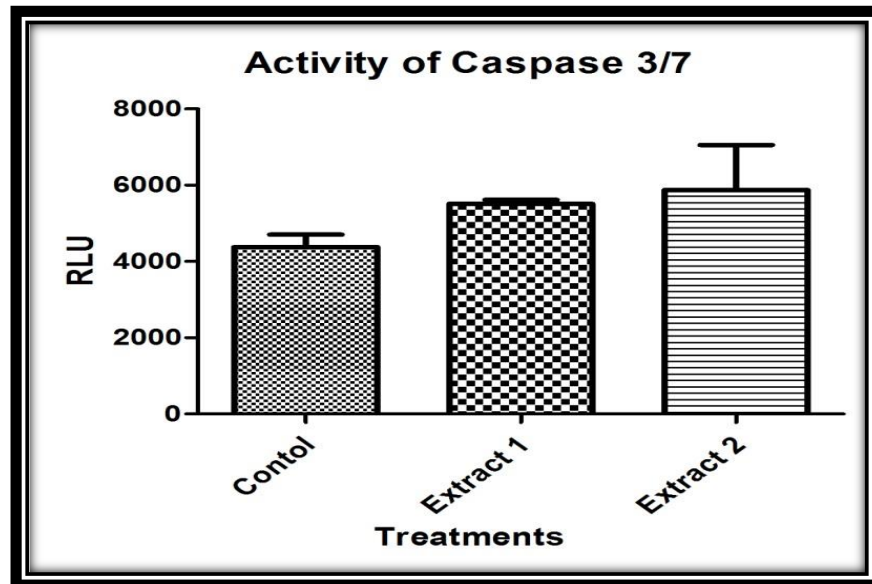

Figure 27: The caspase activities of caspase 3/7, 8 and 9 on Hep G2 cells when they were treated with the extracts. In figure 27 A, the caspase activity for caspase 8 was higher for extract 1 while for figure 27 B, the caspase activity was higher for extract 2 when compared to the control and other extract. Figure 27 C showed that both extracts caused a higher caspase 3/7 activity than the control cells. There were no significance in these caspase activities.

### Comet assay

The comet assay was done to determine the DNA fragmentation of the Hep G2 cells. The control cells were untreated while other Hep G2 cells were treated with the 2 extracts individually. Each slide had a cell suspension of 20 000 cells and were done in triplicate. The results are shown in figure 28 (A-D).

A)

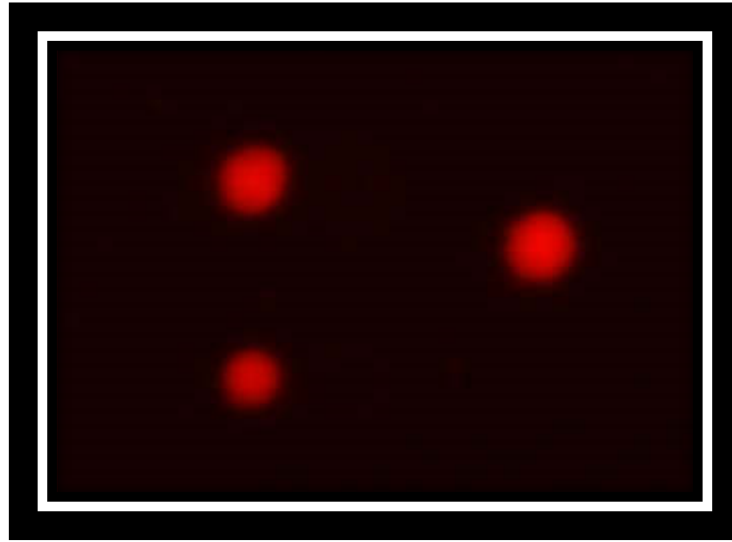

Figure 28 A: Hep G2 cells were observed to be circular in shape for the control cells (Pictures were supplied by author).

B)

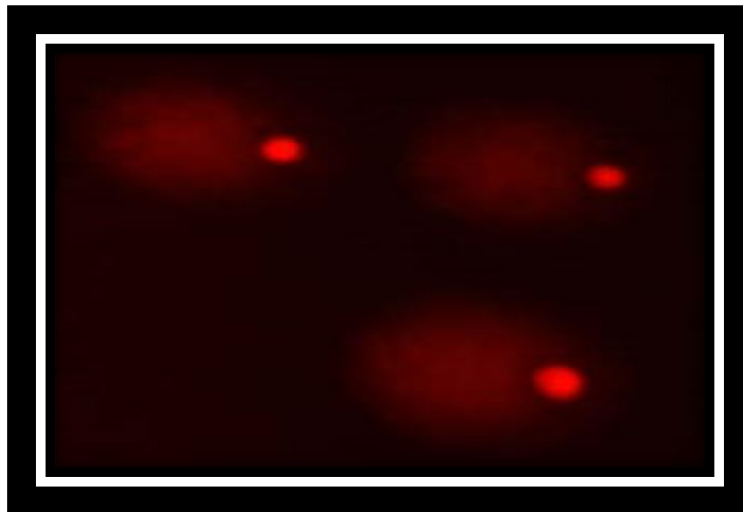

Figure 28 B: Comets were observed when Hep G2 cells were treated with the *B. cereus* extracts for 24 hours (Pictures were supplied by author).

C)

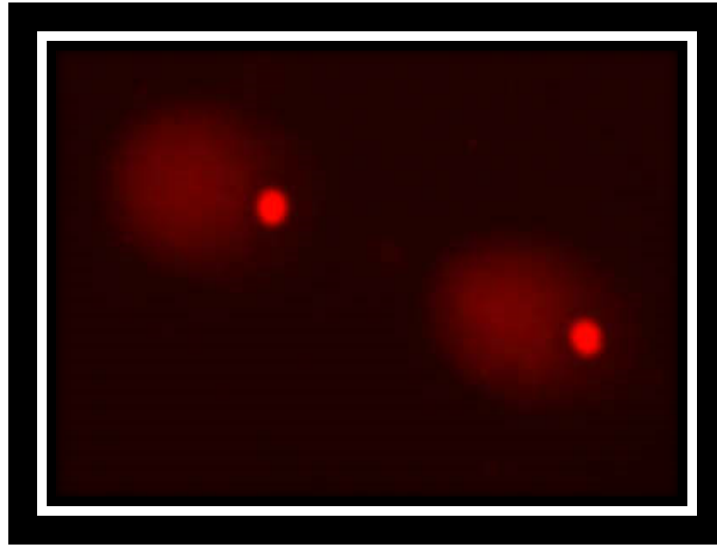

Figure 28 C: Comets were observed when Hep G2 cells were treated with the *V. alginolyticus* extracts for 24 hours (Pictures were supplied by author).

D)

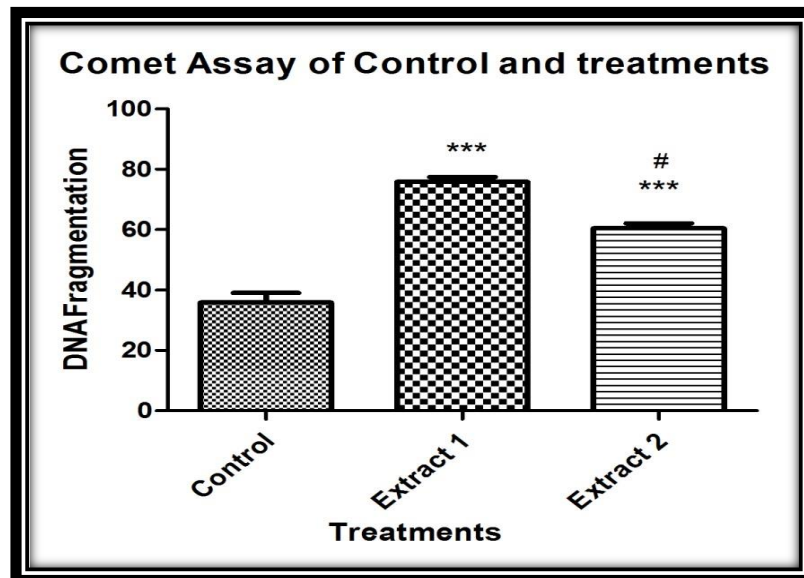

Figure 28: Intact cells and comets were observed under the microscope for the comet assay (A-C). A) Intact cells were observed by the untreated cells. B) Comet tails were observed when Hep G2 cells were

treated with extract 1. C) Comet tails were observed when the Hep G2 cells were treated with extract 2.

D) Comet analysis of the two extracts and the control. The extracts were significantly higher than the control. Extract 1 and 2 were compared to each other and had shown a significance between them. The comet assay indicated that both extracts have a significant degree of DNA fragmentation on the Hep G2 cells. The comparison between the two extracts indicated that *B. cereus* extract was more toxic and therefore had a higher level of DNA fragmentation.

## Chapter 4 – Discussion

Terrestrial organisms produce less diverse secondary metabolites than the marine organisms. Marine organisms live in a unique environment contributing to the novel and distinctive structures of secondary metabolites produced. There is also a diversity of species found in the marine environment and bioactivities of the metabolites are much stronger. Additionally, alongside the studies on marine natural product biosynthesis, there are data that supports the idea that many bioactive compounds that were previously thought to have been produced or metabolised by marine animals and marine plants, were actually produced or metabolised by the associated microbes. There is a low quantity of bioactive compounds in marine animals and marine plants and there is a limit in bioresource supply. This encourages researches to concentrate on marine microbes as a source of novel bioactive secondary metabolites (Zheng et al., 2005).

Selection pressures such as space and nutrient causes competition amongst the marine microorganisms. In response, they will produce many natural products that can have medical and industrial benefits. These types of bacteria can have antimicrobial and antifouling activities depending on the role they have in the different hosts they are on. It is proposed that the main reason why microbes produce antibiotics is because of ecological competition. If this is true, it can be expected that there would be a higher production of antibiotics on specific hosts when compared to other hosts. Unfortunately, there have been limited studies done to compare the antibiotic activities of marine microbes and their hosts they were isolated from (Zheng et al., 2005).

Apoptosis plays an important role in growth, continuation of homeostasis and host immunity in multi-cellular species. When there is no control in apoptosis, this can cause many diseases like cancer, neurodegenerative illness, autoimmune disease and ischemic injuries (Chang and Yang, 2000). It can be left to reason that if the liver is involved in metabolism, detoxification, immunity etc., the people who have a deficient immune system can become extremely ill or die when they consume these harmful foods from fish. It also suggests that people won't be able to metabolize food properly and detoxify substances. The actual implications of apoptosis of the liver cells in humans, is left to speculation.

### **Zone of Inhibition Test**

There was no zone of inhibition produced for the 2 extracts against *S. aureus* ATCC 25923, *E. coli* ATCC 25922 and *P. aeruginosa* ATCC 27853. This suggested that the crude extracts had no antibacterial activity against the 3 reference strains and at the various concentration factors. The metabolites were tested in triplicate and had controls for each of the secondary metabolite tested. There were no zones of inhibition for the negative control (PBS) and the antibiotic (positive control) produced a zone of inhibition that was according to the standards defined in the “Performance Standards for Antimicrobial Susceptibility Testing” for the respective strains.

### **PCR**

The 2 sets of primers used for identifying the DNA of the bacteria isolated were identified as *B. cereus* and *V. alginolyticus*. *Bacillus cereus* produced a band size of 1686 bp and *V. alginolyticus*

produced a band size of 737 bp. The primers were specific and the band sizes corresponded to the band sizes described by Sacchi *et. al.*, 2002 and Di Pinto *et. al.*, 2005.

### **Cell viability assay (MTT)**

The MTT assay showed a decrease in cell viability for both extracts. The number of cells decreased as the dilution decreased. This showed that the extracts had a toxic effect on the Hep G2 cells. The concentration required for 50 % cell death is 0.764 mg/ml and 0.918 mg/ml for *B. cereus* and *V. alginolyticus*, respectively. The crude extract from *B. cereus* needed a lower concentration to cause 50% cell death and was therefore more toxic. The results above show that both the extracts have a toxic effect on the cells.

### **Annexin V and propidium staining**

When apoptosis takes place, the externalization of phosphatidylserine (PS) to the outer leaflet of the plasma membrane occurs. Annexin V-FITC/Propidium iodide (PI) double staining can differentiate apoptotic cells (early or late), necrotic and dead cells. Annexin V is a  $Ca^{2+}$ -dependent protein with high affinity for PS and binds to apoptotic cells exposing PS to the extracellular side of the plasma membrane. For necrotic/dead cells, PI binds to the DNA. Viable cells with intact membranes exclude PI, while the membranes of the dead and damaged cells are permeable to PI. Cells considered as viable are both Annexin V-FITC<sup>-</sup>/PI<sup>-</sup>. Cells in early apoptosis (pro-apoptosis/apoptosis) cells are Annexin V-FITC<sup>+</sup>/PI<sup>-</sup>; while cells in late apoptosis



(i.e. cells that have completed the apoptotic and will start the necrotic process (apoptotic/necrotic)), are both Annexin V-FITC<sup>+</sup>/PI<sup>+</sup> (Prosperini et al., 2013).

Extract 1( $20.83 \pm 0.8737$ ) and 2 ( $25.37 \pm 1.050$ ) showed a higher staining for Annexin V than that of the control ( $11.20 \pm 1.000$ ) (Figure 23). Extract 2 was significant when compared to the control ( $p < 0.0273$ ). For propidium staining, extracts 1( $11.57 \pm 1.387$ ) and 2 ( $11.43 \pm 0.3215$ ) showed a higher staining when compared to the control ( $6.033 \pm 0.4524$ ) (Figure 24). Figures 23 and 24 suggest that extract 1-2 had induced both apoptosis and necrosis. From the results, it is evident that the Hep G2 cells (for both extracts) have undergone both apoptosis and late apoptosis/necrosis. This is observed as the extracts are positive for both Annexin V and propidium iodide.

### **Adenosine triphosphate (ATP) assay**

Apoptosis can be caused by internal and external signals. Apoptosis plays an important role in tissue development and homeostasis as well as the removal of cancerous cells, dysfunctional cells or cells that were infected by viruses. Apoptosis needs energy. The ATP is needed in ATP-dependent steps such as bleb formation, enzymatic hydrolysis of macromolecules, activation of caspases and the forming of apoptotic cells. When there is a decrease in cellular ATP, this causes a switching between cell death. This can be from apoptosis to necrosis. It is now accepted that the quantity of intracellular ATP influences the fate of cell dying either by apoptosis or necrosis (Zamaraeva et al., 2005).

Extracts 1 ( $1.5 \times 10^6 \pm 9.4 \times 10^4$ ) and 2 ( $1.4 \times 10^6 \pm 8.3 \times 10^4$ ) showed a lower level of ATP compared to the control ( $1.83 \times 10^6 \pm 5.82 \times 10^4$ ). This suggested that there were a lower number of viable cells present which could be the result of apoptosis. The quantitation of ATP suggested that there were active and viable cells present. The amount of ATP is directly proportional to the number of cells present. (Promega- Celltiter-Glo luminescent Cell Viability Assay). The control would have a higher level of ATP as it was not treated with any extract. The Hep G2 cells that were treated with the 2 extracts showed a lower ATP level. This indicated that the extracts had a toxic effect on the Hep G2 cells as the ATP level is directly proportional to the number of active and viable cells present.

### **Mitochondrial depolarisation**

The reasons for apoptosis occurring and the way it is executed is not understood very well. Factors such as oxidative stress, proteases, mitochondria, nucleases,  $\text{Ca}^{2+}$  and nitric oxide and its congeners arbitrate apoptosis. The mitochondrial membrane potential ( $\Delta\psi$ ) is responsible for mitochondrial ATP production. The  $\Delta\psi$  decreases during apoptosis while the maintenance of  $\Delta\psi$  stops apoptosis occurring. Since apoptosis includes the activities of vesicle formation, hydrolytic enzymes and chromatin condensation, this suggests that apoptosis requires a high energy level. Richter et. al. suggests that the level of cellular ATP influences cell death. Their hypothesis is confirmed by circumstantial evidence and is consistent with published research. Their research shows a relationship in aging and experimental testing can be done using flow cytometry (Richter et.al., 1990).

Cytochrome c transfers electrons between complex III and cytochrome C oxidase. When there is permeabilisation of the outer mitochondrial membrane followed by a release of high level of cytochrome c, this slows the electron flow. This causes a distortion in the mitochondrial respiratory chain and causes a decrease export level of the H<sup>+</sup> ions from the mitochondrial matrix. Mitochondrial membrane potential depolarisation is a characteristic of apoptosis. The concentration of ATP is reduced drastically during apoptosis (Düßmann et al., 2003).

There is a release of energy during the oxidation reactions in the mitochondrial respiratory chain. The energy is stored as a negative electrochemical gradient across the mitochondrial membrane and the mitochondrial membrane potential ( $\Delta\psi$ ) is referred to as being polarized. The collapse of the mitochondrial membrane potential results in a depolarized mitochondrial membrane potential. This is usually observed during apoptosis.

Extracts 1 ( $30.57 \pm 0.75$ ) and 2 ( $20.53 \pm 8.56$ ) showed a higher level of mitochondrial depolarisation when compared to the control ( $14.83 \pm 1.350$ ). The reason for this would be that the cell integrity was compromised. The viable cells would retain the JC-1 stain while the apoptotic cells would not. Therefore the control would have a higher mitochondrial polarization than compared to the other treatments and the mitochondrial membrane will not be depolarized. The Hep G2 cells that were treated with extracts underwent apoptosis and therefore their mitochondria became depolarised.

### **Thiobarbituric acid reactive substances (TBARS)**

Thiobarbituric acid reactive substances (TBARS) is a low weight lipid peroxidation products mainly consisting of malondialdehyde (Chakraborty et al., 2009). One of the final products of lipid peroxidation is malondialdehyde (MDA). An increase in lipid peroxidation compromises the cell membrane integrity (Salatti Ferrari et al., 2012). Extract 2 showed a higher MDA level than the control while extract 1 showed a lower MDA level when compared to the control. The greater MDA level of the extracts than the MDA level of the control would indicate high lipid peroxidation occurred causing the membrane to be compromised and will ultimately lead to apoptosis. Extract 1's MDA level did not differ greatly to the control's MDA value. Extract 1 caused apoptosis as seen by the other assays performed. It probably did not cause a high level of damage to the cell membrane, thus producing a low level of MDA or perhaps the secondary metabolite may have some repairing function. Another important fact to note is that the TBARS assay is not the most accurate assay for determining oxidative stress.

### **Caspase Activity**

Caspases are a collection of cysteine proteases essential for apoptosis of eukaryotic cells. The deletion of genes that code for murine caspases support that caspases are involved in apoptosis, cytokine maturation as well as cell growth and differentiation. Caspase I and II are mainly responsible in the processing of pro-inflammation cytokines. Caspase 3 and 9 are responsible for apoptosis during brain growth. On the other hand, caspase 8 is responsible for the growth of the heart muscle, cell multiplication in the hematopoietic lineage and apoptosis mediated by death receptors. The function of caspases was clearer when *ced-3* (i.e. a cell death-related gene) was

found to be responsible for the apoptosis in *Caenorhabditis elegans*. *Ced-3* is similar to mammalian caspases. It is evident that caspases are vital effective molecules for causing apoptosis in eukaryotic cells (Wang and Lenardo, 2000).

For figure 27 A, the control, extract 1 and extract 2 have means that were  $4.23 \times 10^4 \pm 3.37 \times 10^3$ ,  $52 \times 10^3 \pm 10.1 \times 10^3$  and  $40 \times 10^3 \pm 5.2 \times 10^3$ , respectively. For figure 27 B, the control, extract 1 and extract 2 have mean that were  $8.6 \times 10^4 \pm 4.6 \times 10^3$ ,  $5.6 \times 10^4 \pm 4 \times 10^3$  and  $9.6 \times 10^4 \pm 5.6 \times 10^4$ , respectively. For figure 27 C, the control, extract 1 and extract 2 have means of  $4.4 \times 10^3 \pm 0.57 \times 10^3$ ,  $5.5 \times 10^3 \pm 0.19 \times 10^3$  and  $5.8 \times 10^3 \pm 2 \times 10^3$ , respectively. Caspase 3/7 showed that apoptosis has occurred with the cells for all extracts used. Extract 1 showed a high caspase activity for caspase 8. This suggests that it follows the extrinsic pathway of apoptosis. Extracts 2 showed a high activity for caspase 9 which suggests that it follows the intrinsic pathway of apoptosis.

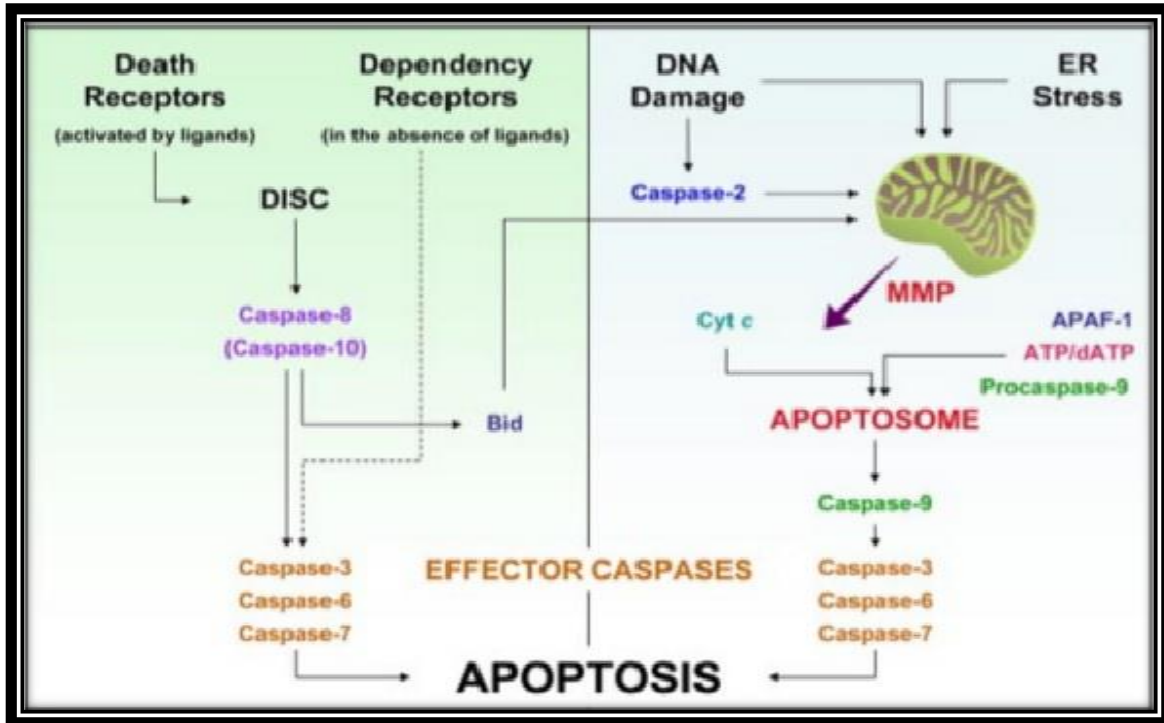

Figure 29: Diagram of the intrinsic and extrinsic pathway of apoptosis. It also shows the caspases that are involved in the respective pathways. The left hand side of the diagram is the extrinsic pathway while the right hand side is the intrinsic pathway. The death receptors that are activated by ligands will promote the assembly of death-inducing signal complex (DISC). This then activates caspase 8 and perhaps, caspase 10. This then causes the cleavage of effector caspases such as caspase 3, 6 and 7. Caspase 8 also activates Bid which is the link between the intrinsic and extrinsic pathway. In the intrinsic apoptotic pathway, many intracellular signals such as DNA damage and endoplasmic reticulum stress (ER) come together on the mitochondria and induce mitochondrial membrane permeabilization (MMP). This will then free the pro-apoptotic factors. One of these factors is cytochrome c, which is responsible for the activating apoptosis protease-activating factor 1 (APAF-1) and ATP/dATP. This then allows for the assembly of the apoptosome which is responsible for the activating the proteolytic activity of caspase 9. Caspase 9 then cleaves and induces caspase 3, 6 and 7. This then leads to apoptosis (Kroemer et al., 2007).

### **Comet assay and summary of all assays done**

The comet assay is a useful tool for DNA fragmentation and oxidative base damage. It can detect DNA fragmentation in apoptotic cells. When the rate of apoptosis increases, so does the extent of DNA damage. Deoxyribonucleic acid (DNA) damage is measured by the tail moment and tail length ((Hao et al., 2009).

The DNA fragmentation of the 2 extracts (i.e.  $75.85 \pm 11.43$  and  $60.48 \pm 11.86$ ) was greater than that of the control ( $35.91 \pm 21.93$ ). It was significant ( $p < 0.0001$ ). When the extracts were compared to each other, it was significant as well ( $p < 0.0001$ ).

In another study, the comet assay was used for testing the effects of siRNA directed against c-mys on Colo 320 cells (a human colon cancer line). The results showed that some apoptotic cells could not be detected by the comet assay. However, all the comets observed were comets of apoptotic cells (Hao et al., 2009).

The Annexin V and propidium staining showed the 2 extracts had caused cells to undergo early apoptosis and late apoptosis/necrosis. There were significance for extract 2 on the Hep G2 cells in the Annexin V assay. There was no significance for extract 1 on the cells. The propidium staining showed no significant effect on the Hep G2 cells. However, there was a higher percentage of propidium staining when compared to the control cells. The caspase activities of caspase 8, 9 and 3/7 showed no significant effect on the Hep G2 cells. Extract 1 showed a greater

degree of caspase 8 activity. This is due to it using the extrinsic pathway of apoptosis. Extract 2 showed a greater degree in caspase 9 activities. This could be due to the extract causing the intrinsic pathway of apoptosis to be activated. Both extracts had an effect on the Hep G2 cells and showed a higher level of caspase 3/7 activity than compared to the control cells. The Annexin V/propidium staining and caspase activities have shown that the extracts from the *B. cereus* and *V. alginolyticus* have undergone apoptosis/necrosis. The ATP and mitochondrial depolarisation assays further emphasizes these results. In the ATP assay, the Hep G2 cells that were treated with the crude extracts of the bacterial strains showed a decrease in ATP levels than the cells that were not treated. There were no significance in the ATP assay. The mitochondrial depolarisation assay showed a higher level of depolarisation in the Hep G2 cells that were treated with the extracts than the control cells. There were no significance. Although, there were no significant results for the ATP assays, it is clear that there is a decrease in the ATP level of the cells treated with the extracts. The decrease in ATP level and mitochondrial depolarisation is due to the cells undergoing apoptosis.

From the cell viability assay, the extracts from *B. cereus* needed a lower concentration to cause 50% cell death. This suggested that it was more toxic than the extracts produced by *V. alginolyticus*. This was then further supported by assays such as mitochondrial depolarisation and the comet assay. The crude extracts are most probably secondary metabolites produced by these marine bacteria. These secondary metabolites can be toxins. The most likely toxins responsible for apoptosis is enterotoxins or cereulide from *B. cereus* and TLH from *V. alginolyticus*. Other studies described below show evidence of the effect of these toxins on Hep G2 cells and other cell lines.



### ***Bacillus cereus*' enterotoxins**

*Bacillus cereus* enterotoxins Nhe (non-hemolytic enterotoxin), HBL (hemolysin BL) and CytK (cytotoxin K) were tested for toxicity against different target cell lines. One of the cell lines is Hep G2. Non-hememolytic enterotoxin plus haemolysin BL showed cytotoxicity to Hep G2, A549 and Vero cells. A reference *B. cereus* strain, F4430/73, which is a Nhe/HBL producing strain was used to show this cytotoxicity to these 2 cell lines. In most of the cell lines, HBL and Nhe caused 40-60% cytotoxicity (Jeßberger et al., 2014).

### **Lipophilic phycotoxins tested on different cell lines**

Lipophilic phycotoxins such as okadaic acid (OA), pectenotoxin – 2 (PTX2) and azaspiracid-1 (AZA1) were tested against Hep G2, mouse neuronal (Neuro2a) and human intestinal (CaCo2) for cytotoxicity. Azaspiracid – 1 caused cytotoxicity on Neuro2a and Hep G2 cells, but not on CaCo2 cells. AZA-1 caused a high level of cytotoxicity on Hep G2 and Neuro2a cells above 5nM after 48 hour incubation (Serandour et al., 2012). The rest of the data is represented in the graphs below:

### A: OA

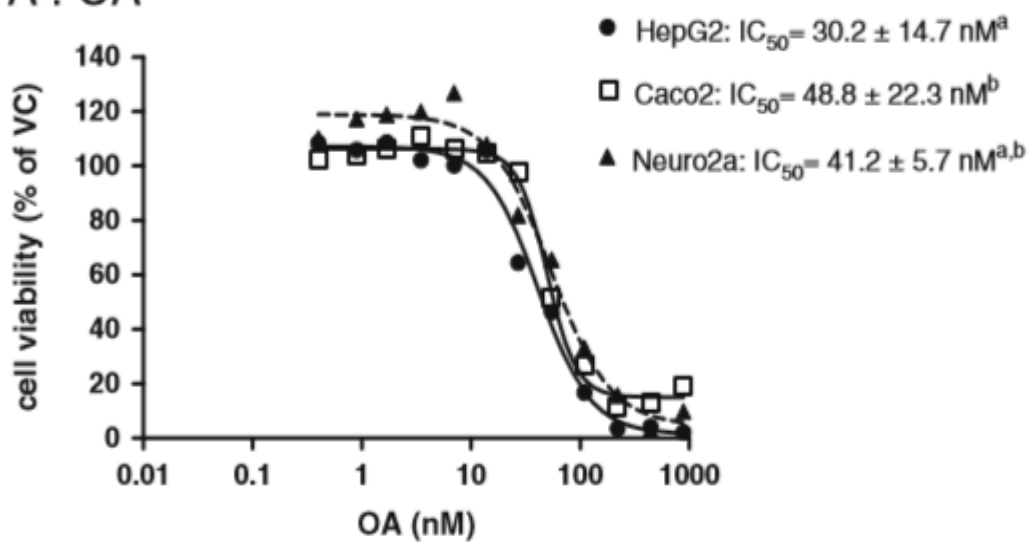

### B: AZA1

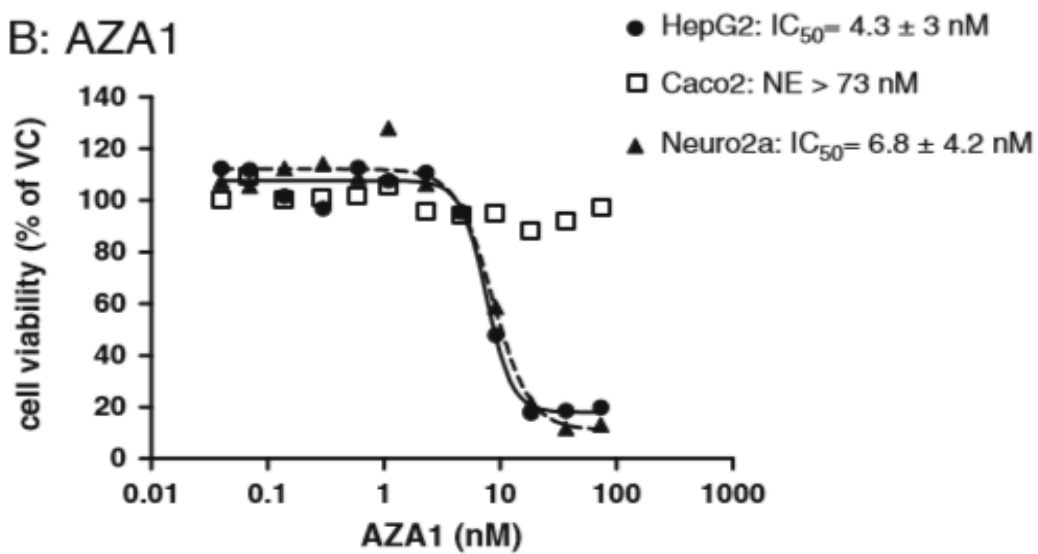

### C: PTX2

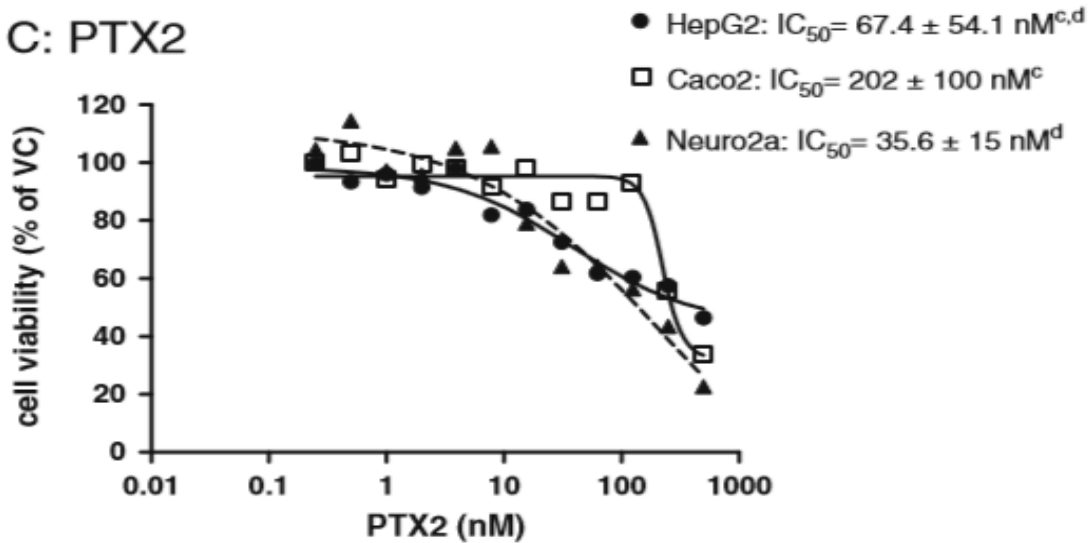

Figure 30 (A-C): IC<sub>50</sub> values were determined by the MTT assay for different toxins on the different cell lines used (Serandour et al., 2012).

#### ***Bacillus cereus*' emetic toxin tested on Hep G2 and Hep-2 cells**

Another study tested *B. cereus* emetic toxin on Hep G2 and Hep-2. The cells were exposed to this toxin and the cell shape was observed. Hep G2 displayed a clear vacuolation in the cytosol (within 2 hours) while Hep-2 needed 10 hrs. There were also a higher number of vacuoles in Hep G2 cells and the size of the vacuoles was bigger as compared to Hep-2 cells. It was noted that Hep G2 needed a lower concentration (0.04 ng/ml) to cause vacuolation of cells while Hep-2 needed 1ng/ml. This study concluded that Hep G2 cells were more sensitive to the toxin as compared to Hep-2 cells (Kamata et al., 2012).

### Thermolabile hemolysin (TLH) from *Vibrio alginolyticus*

A recombinant thermolabile hemolysin (TLH) from *V. alginolyticus* was tested on nucleated erythrocytes of silver sea bream (*Sparus sarba*). It resulted in apoptosis and necrosis of these cells. Assays detecting caspase 3, caspase 8 and caspase 9/6 activities and DNA fragmentation using TUNEL and DNA ladder assays were done. Transmission electron microscopy (TEM) showed membrane vesiculation which had protrusion on the plasma membrane. Necrosis was evident by the breakdown of plasma membrane which leads to the release of haemoglobin and other cytoplasmic material. Changes in cell sizes were seen by using flow cytometry (Wong et al., 2012).

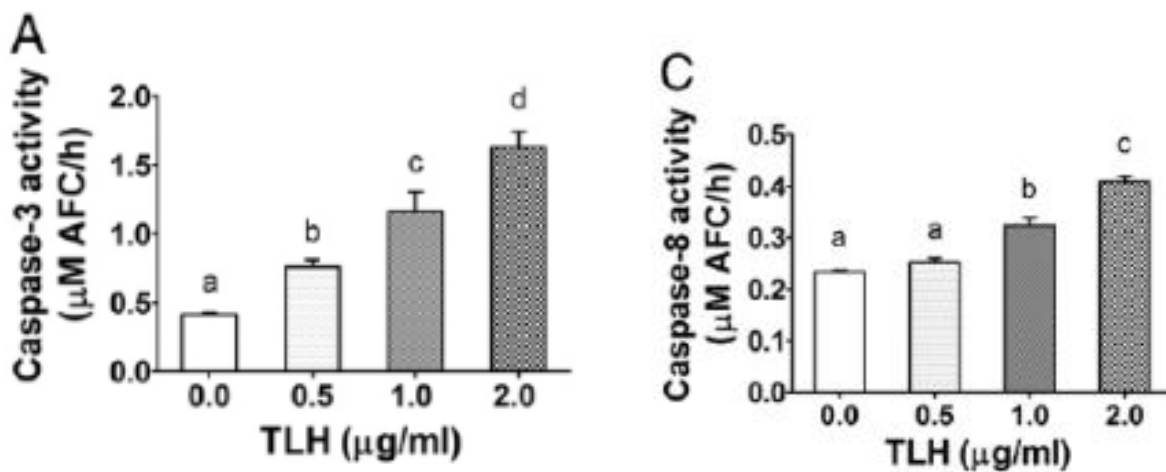

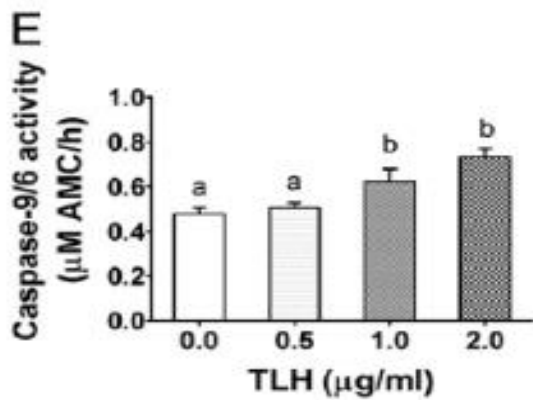

Figure 31 (A, C, E): The caspase activities of caspase 3,-8 and -9/6 when exposed to TLH from *V. alginolyticus*. The activities increased significantly when incubated with TLH. The control was TRIS-HCL while cells were treated with 0.5µg/ml, 1.0 µg/ml and 2.0 µg/ml of TLH. The a and b denotes the significant difference between the mean values ( $p < 0.05$ ) (Wong et al., 2012).

#### DNA fragmentation by TUNEL assay

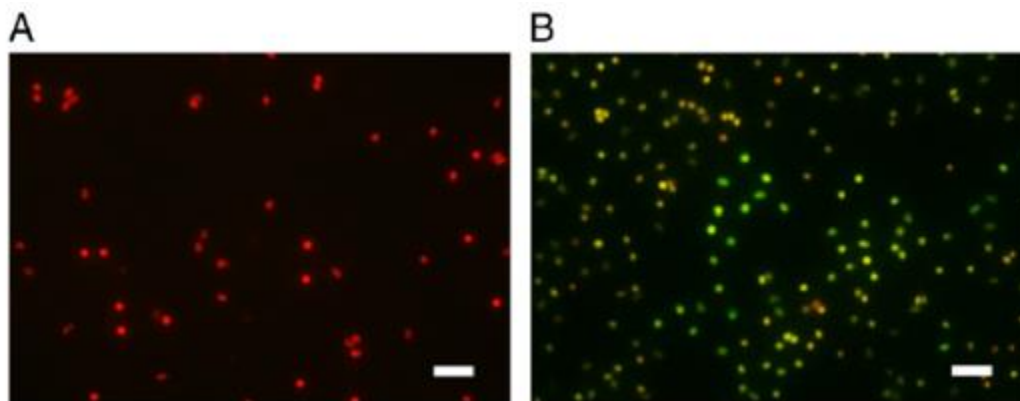

Figure 32: Double staining of green fluorescence and PI staining were done. Intact DNA (control group) fluorescence red while DNA that was fragmented fluorescence yellowish green (Wong et al., 2012).

### Morphological changes in erythrocytes

Control cells retained its shape with an intact plasma membrane form while cells treated with TLH for 12 hrs, had an irregular shape with protrusions on the plasma membrane (Wong et al., 2012).

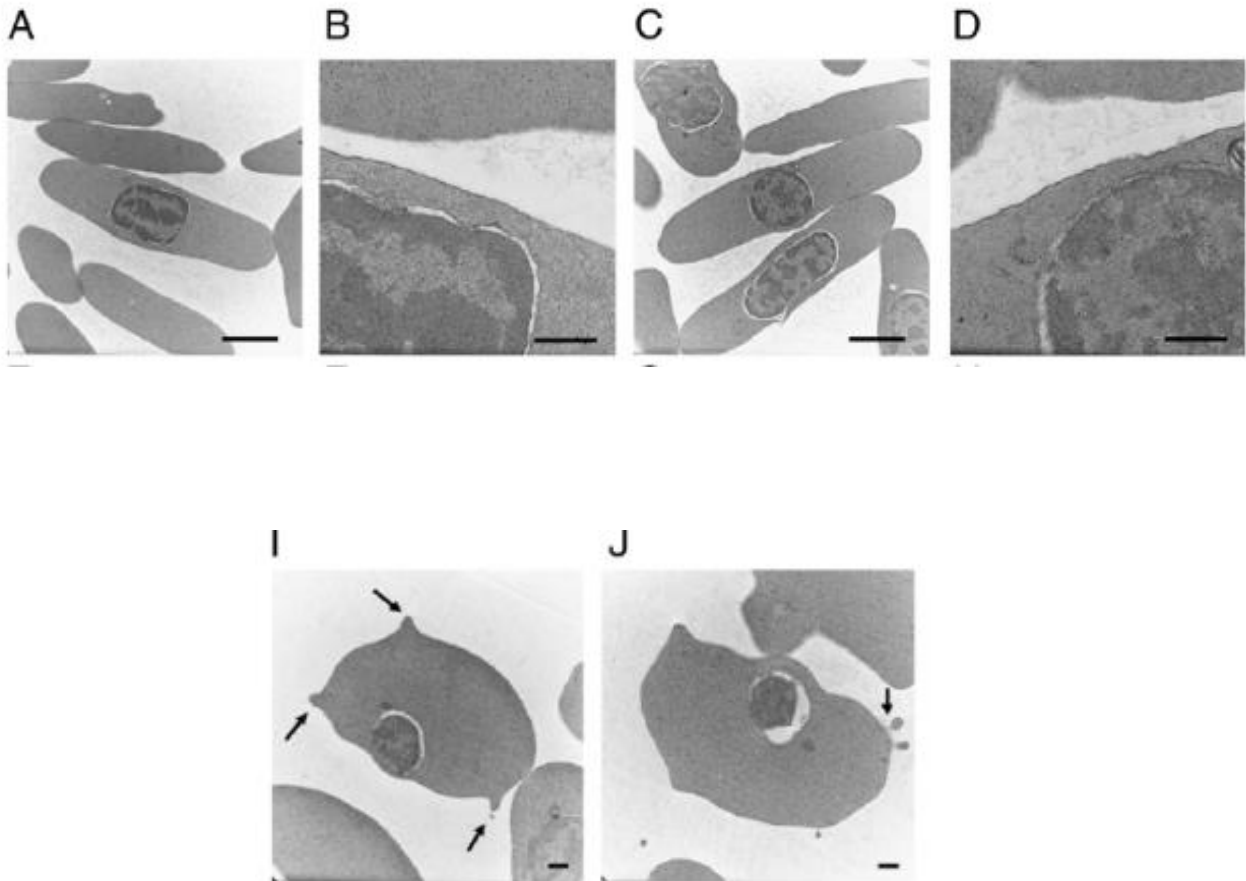

Figure 33: Pictures A-D depicts the control cells that were not exposed to TLH while pictures I-J depicts the cells that were exposed to TLH. The cells that were treated with TLH have protrusions and showed vesiculation on the plasma membrane (Wong et al., 2012).

### **Effect of TLH dosage on necrosis and DNA fragmentation**

Deoxyribonucleic acid (DNA) fragmentation as well as necrosis was measured when cells were exposed to TLH simultaneously. Different levels of TLH was tested against the cells. It was observed as the concentration of TLH increased, the higher the DNA fragmentation. This suggested that apoptosis increased as the concentration of TLH increased. Necrosis was measured by the release of haemoglobin. This occurred throughout the process of apoptosis. As the TLH concentration increase, so did necrosis (Wong et al., 2012).

Thermolabile hemolysin (TLH) can cause apoptosis in sea bream erythrocytes. This was observed by activated caspase activities and DNA fragmentation. The increase in caspase 8 and caspase 9 suggested that the intrinsic and extrinsic pathway play a role in apoptosis. Activation of caspase 8 occurs with *V. alginolyticus hemolysin* and no other *Vibrio* species. The mechanism of TLH causing apoptosis of erythrocytes is unknown. From the data above, apoptosis, membrane vesiculation and necrosis occurred when the erythrocytes was treated with TLH. Cells did not die just by the process of apoptosis but necrosis as well and nuclear envelopes were reported to have not collapsed. The authors proposed that in natural infection, *V. alginolyticus* will replicate while necrosis is taking place, as a result of iron from haemoglobin is available. It is not fully understood if membrane vesiculation of fish erythrocytes after a similar protection mechanism as in human erythrocytes. In this protection mechanism, vesicles are responsible for removing molecules which play a role in signalling macrophage phagocytosis. This therefore stops their elimination. It is also uncertain why there is no collapse of the nuclear envelope.

Therefore more research needs to be done to find out the answers to these questions (Wong et al., 2012).



## Chapter 5 – Conclusion

The marine environment can be a rich source of secondary metabolites. Marine microbes are examples of organisms that can provide these secondary metabolites. There is an urgent need to discover novel secondary metabolites to treat diseases, e.g. cancer, and solve the antibiotic resistance issue.

The findings of this study resulted in the confirmation of the bacteria being *B. cereus* and *V. alginolyticus*. There was no antibacterial activity when tested against *Staphylococcus aureus* ATCC 25923, *E. coli* ATCC 25922 and *P. aeruginosa* ATCC 27853 for the various concentration factors. The secondary metabolites/crude extracts from the marine bacteria have shown cell toxicity on the Hep G2 cell line. There was a decrease in cell viability which was shown with the cell viability assay. The ATP assay, mitochondrial depolarisation assay, TBARS, caspases and Annexin V/propidium assays done suggested apoptosis and late apoptosis/necrosis occurred. The comet assay further showed that the cells underwent DNA fragmentation suggesting that cell damage occurred. The crude extracts from the marine bacteria have the potential of killing Hep G2 cells, therefore the crude extracts needs further studies to be done on them. This will allow for the identification and characterization of the many different components that may exist in the individual bacteria. It however could possibly be the toxins that the bacteria produce under selective pressures. The speculation is that these toxins are the emetic or cereulide toxin produced by *B. cereus* and TLH produced by *V. alginolyticus*, as other studies have shown apoptosis/necrosis with Hep G2 cells itself or other cell lines. If this is the case, the secondary metabolites cannot be used in the treatment of cancer. It can be speculated that since the liver has many functions, apoptosis can have serious implications to one's health.

Unfortunately there were no antibacterial activity against the reference strains of *E. coli*, *S. aureus* and *P. aeruginosa*, especially since novel antibiotics are needed. This study might have not produced any novel antibiotic but there is still more research that can be done exploring the marine waters and the different marine microbes that exist in them.

## References

Identifying Unknown Bacteria Using Biochemical and Molecular Methods

<http://www.nslc.wustl.edu/elgin/genomics/Bio3055/IdUnknBacteria06.pdf>. Accessed on 13/05/2013, 2:15 pm.

KWAZULU- NATAL SHARKS BOARD. SHARK SPECIES.

<http://www.shark.co.za/SharkSpecies>. Accessed on 03/05/2013, 1:23 pm.

2012. News. *Marine Pollution Bulletin*, 64, 1733-1736.

AULICINO, F. A., ORSINI, P., CARERE, M. & MASTRANTONIO, A. 2001. Bacteriological and virological quality of seawater bathing areas along the Tyrrhenian coast. *Int J Environ Health Res*, 11, 5-11.

AUSTIN, B. 1999. The effects of pollution on fish health. *Journal of Applied Microbiology*, 85.

BOSSY-WETZEL, E. & GREEN, D. R. 2000. Detection of apoptosis by annexin V labeling. *Methods Enzymol*, 322, 15-8.

BUCK, J. D., SPOTTE, S. & GADBAW, J. J., JR. 1984. Bacteriology of the teeth from a great white shark: potential medical implications for shark bite victims. *J Clin Microbiol*, 20, 849-51.

CEUPPENS, S., RAJKOVIC, A., HAMELINK, S., VAN DE WIELE, T., BOON, N. & UYTTENDAELE, M. 2012. Enterotoxin production by *Bacillus cereus* under gastrointestinal conditions and their immunological detection by commercially available kits. *Foodborne Pathog Dis*, 9, 1130-6.

CHAKRABORTY, S., SINGH, O. P., DASGUPTA, A., MANDAL, N. & NATH DAS, H. 2009. Correlation between lipid peroxidation-induced TBARS level and disease severity in obsessive-compulsive disorder. *Prog Neuropsychopharmacol Biol Psychiatry*, 33, 363-6.

CHANG, H. Y. & YANG, X. 2000. Proteases for cell suicide: functions and regulation of caspases. *Microbiol Mol Biol Rev*, 64, 821-46.

CHRISTENSEN, M. E., JANSEN, E. S., SANCHEZ, W. & WATERHOUSE, N. J. 2013. Flow cytometry based assays for the measurement of apoptosis-associated mitochondrial membrane depolarisation and cytochrome c release. *Methods*, 61, 138-45.

CLSI. Performance Standards for Antimicrobial Susceptibility Testing: Nineteenth Information Supplement. CLSI document M100-S19. Wayne, PA: Clinical and Laboratory Standards Institute, 2009.

COLLINS, A. R. 2004. The comet assay for DNA damage and repair: principles, applications, and limitations. *Mol Biotechnol*, 26, 249-61.

DAMIR, K., IRENA, V. S., DAMIR, V. & EMIN, T. 2013. Occurrence, characterization and antimicrobial susceptibility of *Vibrio alginolyticus* in the Eastern Adriatic Sea. *Marine Pollution Bulletin*, 75, 46-52.

DANIELS, N. A. & SHAFIAIE, A. 2000. A review of pathogenic *Vibrio* infections for clinicians. *Infections in Medicine*, 17, 665-685.  
[http://issc.org/client\\_resources/education/pathogenicvibrioinfections.pdf](http://issc.org/client_resources/education/pathogenicvibrioinfections.pdf)

DAVIDSON, B., ZAYED, M., ZAYED, S. & CLIFF, G. 2011. Liver lipids of Indian and Atlantic Ocean spinner *Carcharhinus brevipinna* and blacktip *Carcharhinus limbatus* sharks. *African Journal of Marine Science*, 33, 115-118. doi: 10.2989/1814232X.2011.572360

DEBBAB, A., ALY, A. H., LIN, W. H. & PROKSCH, P. 2010. Bioactive Compounds from Marine Bacteria and Fungi. *Microbial Biotechnology*, 3, 544-563.

Dennison, C. 2002. Principles in Electrophoresis. *A Guide to Protein Isolation*, Springer Netherlands: 115-149.

DI PINTO, A., CICCARESE, G., TANTILLO, G., CATALANO, D. & FORTE, V. T. 2005. A collagenase-targeted multiplex PCR assay for identification of *Vibrio alginolyticus*, *Vibrio cholerae*, and *Vibrio parahaemolyticus*. *J Food Prot*, 68, 150-3.

- DROBNIIEWSKI, F. A. 1993. *Bacillus cereus* and related species. *Clin Microbiol Rev*, 6, 324-38.
- DÜßMANN, H., REHM, M., KÖGEL, D. & PREHN, J. H. M. 2003. Outer mitochondrial membrane permeabilization during apoptosis triggers caspase-independent mitochondrial and caspase-dependent plasma membrane potential depolarization: a single-cell analysis. *Journal of Cell Science*, 116, 525-536. doi: 10.1242/jcs.00236
- EMMERT, E. A., KLIMOWICZ, A. K., THOMAS, M. G. & HANDELSMAN, J. 2004. Genetics of zwittermicin A production by *Bacillus cereus*. *Appl Environ Microbiol*, 70, 104-113. doi: 10.1128/AEM.70.1.104-113.2004
- GONZALEZ-ESCALONA, N., BLACKSTONE, G. M. & DEPAOLA, A. 2006. Characterization of a *Vibrio alginolyticus* strain, isolated from Alaskan oysters, carrying a hemolysin gene similar to the thermostable direct hemolysin-related hemolysin gene (trh) of *Vibrio parahaemolyticus*. *Appl Environ Microbiol*, 72, 7925-9. doi: 10.1128/AEM.01548-06
- HAO, H., NANCAI, Y., WEN, S. & XIAOJUAN, Q. 2009. The single-cell gel electrophoresis assay to determine apoptosis induced by siRNA in Colo 320 cells. *African Journal of Biotechnology*, 8. doi: 10.5897/AJB09.466
- INTERAMINENSE, J. A., NASCIMENTO, D. C., VENTURA, R. F., BATISTA, J. E., SOUZA, M. M., HAZIN, F. H., PONTES-FILHO, N. T. & LIMA-FILHO, J. V. 2010. Recovery and screening for antibiotic susceptibility of potential bacterial pathogens from the oral cavity of shark species involved in attacks on humans in Recife, Brazil. *J Med Microbiol*, 59, 941-7.
- JEBBERGER, N., DIETRICH, R., BOCK, S., DIDIER, A. & MÄRTLBAUER, E. 2014. *Bacillus cereus* enterotoxins act as major virulence factors and exhibit distinct cytotoxicity to different human cell lines. *Toxicon*, 77, 49-57.
- KAMATA, Y., KANNO, S., MIZUTANI, N., AGATA, N., KAWAKAMI, H., SUGIYAMA, K. & SUGITA-KONISHI, Y. 2012. Sensitivity of Hep G2 cells to *Bacillus cereus* emetic toxin. *J Vet Med Sci*, 74, 1483-5.
- KELECOM, A. 2002. Secondary metabolites from marine microorganisms. *An Acad Bras Cienc*, 74, 151-70.

KNIP, D. M., HEUPEL, M. R. & SIMPFENDORFER, C. A. 2012. Evaluating marine protected areas for the conservation of tropical coastal sharks. *Biological Conservation*, 148, 200-209.

KOTIRANTA, A., LOUNATMAA, K. & HAAPASALO, M. 2000. Epidemiology and pathogenesis of *Bacillus cereus* infections. *Microbes and Infection*, 2, 189-198.

KROEMER, G., GALLUZZI, L. & BRENNER, C. 2007. Mitochondrial membrane permeabilization in cell death. *Physiol Rev*, 87, 99-163.

LANGERGRABER, G. & MUELLEGGER, E. 2005. Ecological Sanitation—a way to solve global sanitation problems? *Environment International*, 31, 433-444.  
doi:10.1016/j.envint.2004.08.006

LIN, J., YAN, X. J., ZHENG, L., MA, H. H. & CHEN, H. M. 2005. Cytotoxicity and apoptosis induction of some selected marine bacteria metabolites. *J Appl Microbiol*, 99, 1373-82.

MEMA, V. Impact of poorly maintained wastewater and sewage treatment plants: Lessons from South Africa. Wisa Conference, ICC Durban, 2010.  
[http://www.ewisa.co.za/literature/files/335\\_269%20Mema.pdf](http://www.ewisa.co.za/literature/files/335_269%20Mema.pdf)

MI, N. A. 2012. Isolation and identification of secondary metabolites producing organisms from marine sponge. *Discovery*, 1, 14-17.  
[http://www.discovery.org.in/PDF\\_Files/d\\_20120703.pdf](http://www.discovery.org.in/PDF_Files/d_20120703.pdf)

MORTIMER, D. 2007. Fishy food facts: how much fish should we eat? *Significance*, 4, 108-112.

MTHEMBU, M. S., DJAROVA, T. G. & BASSON, A. K. 2012. The Effect of Human Activities on the Quality of Water at UMhlatuze River (Northern Coast of Kwa-Zulu Natal, RSA): The Case of Agricultural and Industrial Developments. *Journal of Agricultural Science & Technology A*, 2, 591-597. <http://davidpublishing.com/show.html?5829>

NARRACCI, M., ACQUAVIVA, M. I. & CAVALLO, R. A. 2013. Mar Piccolo of Taranto: *Vibrio* biodiversity in ecotoxicology approach. *Environ Sci Pollut Res Int*.

- NEWBOLD, R. W., JENSEN, P. R., FENICAL, W. & PAWLIK, J. R. 1999. Antimicrobial activity of Caribbean sponge extracts. *Aquatic microbial ecology*, 19, 279-284. doi:10.3354/ame019279
- NYBAKKEN, J. W. & WEBSTER, S. K. 1998. Life in the Ocean. *Scientific American Presents*, 74-86. [www.ws.k12.ny.us/Downloads/life\\_in\\_the\\_ocean2.pdf](http://www.ws.k12.ny.us/Downloads/life_in_the_ocean2.pdf)
- OAKES, K. D. & VAN DER KRAAK, G. J. 2003. Utility of the TBARS assay in detecting oxidative stress in white sucker (*Catostomus commersoni*) populations exposed to pulp mill effluent. *Aquat Toxicol*, 63, 447-63.
- PABBA, S. K., SAMATHA, B., PRASAD, M. R. & HIMABINDU, S. 2011. Isolation and screening of marine bacteria for antimicrobial activity along Vishakapatnam Coast. *Journal of Microbiology and Biotechnology Research*, 1, 86-88. <http://scholarsresearchlibrary.com/JMB-vol1-iss2/JMB-2011-1-2-86-89.pdf>
- PROSPERINI, A., JUAN-GARCIA, A., FONT, G. & RUIZ, M. J. 2013. Reactive oxygen species involvement in apoptosis and mitochondrial damage in Caco-2 cells induced by enniatins A, A1, B and B1. *Toxicol Lett*, 222, 36-44.
- Richter, C., et al. (1996). "Control of apoptosis by the cellular ATP level." *FEBS Lett* **378**(2): 107-110.
- ROLINSON, G. & RUSSELL, E. J. 1972. New method for antibiotic susceptibility testing. *Antimicrobial Agents and Chemotherapy*, 2, 51-56. <http://www.ncbi.nlm.nih.gov/pmc/articles/PMC444266/pdf/aac00362-0001.pdf>
- RUIZ, B., CHAVEZ, A., FORERO, A., GARCIA-HUANTE, Y., ROMERO, A., SANCHEZ, M., ROCHA, D., SANCHEZ, B., RODRIGUEZ-SANOJA, R., SANCHEZ, S. & LANGLEY, E. 2010. Production of microbial secondary metabolites: regulation by the carbon source. *Crit Rev Microbiol*, 36, 146-67.
- SACCHI, C. T., WHITNEY, A. M., MAYER, L. W., MOREY, R., STEIGERWALT, A., BORAS, A., WEYANT, R. S. & POPOVIC, T. 2002. Sequencing of 16S rRNA gene: a rapid tool for identification of *Bacillus anthracis*. *Emerging infectious diseases*, 8, 1117. doi: 10.3201/eid0810.020391

- SALATTI FERRARI, R., DA ROSA, D. P., FORGIARINI, L. F., BONA, S., DIAS, A. S. & MARRONI, N. P. 2012. Oxidative stress and pulmonary changes in experimental liver cirrhosis. *Oxid Med Cell Longev*, 2012, 486190.
- SAMALI, A., NORDGREN, H., ZHIVOTOVSKY, B., PETERSON, E. & ORRENIUS, S. 1999. A comparative study of apoptosis and necrosis in HepG2 cells: oxidant-induced caspase inactivation leads to necrosis. *Biochem Biophys Res Commun*, 255, 6-11.
- SERANDOUR, A. L., LEDREUX, A., MORIN, B., DERICK, S., AUGIER, E., LANCELEUR, R., HAMLAOUI, S., MOUKHA, S., FURGER, C., BIRE, R., KRYS, S., FESSARD, V., TROUSSELLIER, M. & BERNARD, C. 2012. Collaborative study for the detection of toxic compounds in shellfish extracts using cell-based assays. Part I: screening strategy and pre-validation study with lipophilic marine toxins. *Anal Bioanal Chem*, 403, 1983-93.
- SETIOWATY, G. & CHE MAN, Y. B. 2003. A rapid Fourier transform infrared spectroscopic method for the determination of 2-TBARS in palm olein. *Food Chemistry*, 81, 147-154.
- SHAHIDUL ISLAM, M. & TANAKA, M. 2004. Impacts of pollution on coastal and marine ecosystems including coastal and marine fisheries and approach for management: a review and synthesis. *Marine Pollution Bulletin*, 48, 624-649.
- SORIA-MERCADO, I. E., VILLARREAL-GÓMEZ, L. J., RIVAS, G. G. & SÁNCHEZ, N. E. A. 2012. *Bioactive Compounds from Bacteria Associated to Marine Algae*. doi: 10.5772/27842
- STENFORS ARNESEN, L. P., FAGERLUND, A. & GRANUM, P. E. 2008. From soil to gut: *Bacillus cereus* and its food poisoning toxins. *FEMS Microbiol Rev*, 32, 579-606.
- TEASDALE, M. E., LIU, J., WALLACE, J., AKHLAGHI, F. & ROWLEY, D. C. 2009. Secondary Metabolites Produced by the Marine Bacterium *Halobacillus salinus* That Inhibit Quorum Sensing-Controlled Phenotypes in Gram-Negative Bacteria. *Applied and Environmental Microbiology*, 75, 567-572. doi:10.1128/AEM.00632-08
- Unger, N. R., et al. (2014). "Antibiotic susceptibilities of bacteria isolated within the oral flora of Florida blacktip sharks: guidance for empiric antibiotic therapy." *PLoS One* 9(8): e104577.



- VALONES, M. A. A., GUIMARÃES, R. L., BRANDÃO, L. A. C., SOUZA, P. R. E. D., CARVALHO, A. D. A. T. & CROVELA, S. 2009. Principles and applications of polymerase chain reaction in medical diagnostic fields: a review. *Brazilian Journal of Microbiology*, 40, 1-11. doi:10.1590/S1517-83822009000100001
- VAN MEERLOO, J., KASPERS, G. J. & CLOOS, J. 2011. Cell sensitivity assays: the MTT assay. *Methods Mol Biol*, 731, 237-45.
- VERLECAR, X. N., SNIGDHA, DESAI, S. R. & DHARGALKAR, V. K. 2007. Shark hunting - an indiscriminate trade endangering elasmobranchs to extinction. *Current Science (00113891)*, 92, 1078-1082.
- VERMES, I., HAANEN, C. & REUTELINGSPERGER, C. 2000. Flow cytometry of apoptotic cell death. *J Immunol Methods*, 243, 167-90.
- VERMES, I., HAANEN, C., STEFFENS-NAKKEN, H. & REUTELINGSPERGER, C. 1995. A novel assay for apoptosis. Flow cytometric detection of phosphatidylserine expression on early apoptotic cells using fluorescein labelled Annexin V. *J Immunol Methods*, 184, 39-51.
- WAFAR, M., VENKATARAMAN, K., INGOLE, B., AJMAL KHAN, S. & LOKABHARATHI, P. 2011. State of Knowledge of Coastal and Marine Biodiversity of Indian Ocean Countries. *PLoS ONE*, 6, e14613. doi:10.1371/journal.pone.00141613
- WANG, J. & LENARDO, M. J. 2000. Roles of caspases in apoptosis, development, and cytokine maturation revealed by homozygous gene deficiencies. *J Cell Sci*, 113 ( Pt 5), 753-7.
- WILLEY, J. M., SHERWOOD, L. M., PRESCOTT, L. M. & WOOLVERTON, C. J. 2008. *Prescott, Harley, and Klein's Microbiology*, McGraw-Hill Higher Education.
- WONG, S. K., ZHANG, X.-H. & WOO, N. Y. S. 2012. *Vibrio alginolyticus* thermolabile hemolysin (TLH) induces apoptosis, membrane vesiculation and necrosis in sea bream erythrocytes. *Aquaculture*, 330-333, 29-36.
- WU, R. S. S. 1999. Eutrophication, Water Borne Pathogens and Xenobiotic Compounds: Environmental Risks and Challenges. *Marine Pollution Bulletin*, 39, 11-22.

- ZAMARAEVA, M. V., SABIROV, R. Z., MAENO, E., ANDO-AKATSUKA, Y., BESSONOVA, S. V. & OKADA, Y. 2005. Cells die with increased cytosolic ATP during apoptosis: a bioluminescence study with intracellular luciferase. *Cell Death Differ*, 12, 1390-7.
- ZHANG, X. H. & AUSTIN, B. 2005. Haemolysins in *Vibrio* species. *Journal of Applied Microbiology*, 98, 1011-1019.
- ZHAO, Z., CHEN, C., HU, C. Q., REN, C. H., ZHAO, J. J., ZHANG, L. P., JIANG, X., LUO, P. & WANG, Q. B. 2010. The type III secretion system of *Vibrio alginolyticus* induces rapid apoptosis, cell rounding and osmotic lysis of fish cells. *Microbiology*, 156, 2864-72.
- ZHENG, L., HAN, X., CHEN, H., LIN, W. & YAN, X. 2005. Marine bacteria associated with marine macroorganisms: the potential antimicrobial resources. *Ann Microbiol*, 55, 119-24. [http://www.annmicro.unimi.it/full/55/zheng\\_55\\_119-124.pdf](http://www.annmicro.unimi.it/full/55/zheng_55_119-124.pdf)