

# NEUTRO À TERRA

Revista Técnico-Científica

<http://www.neutroaterra.blogspot.com>

*Num contexto mundial sem precedentes devido a uma pandemia que está a abalar o mundo, com consequências catastróficas nas economias de todos os países, voltamos à vossa presença com mais uma edição da revista “Neutro à Terra”, que já vai na sua vigésima quinta publicação. Compete-nos a todos agir com competência e responsabilidade, de forma a minimizar os efeitos devastadores que a situação atual terá na vida das pessoas. Neste contexto, as questões ambientais e a sustentabilidade energética tomam uma importância acrescida. Neste âmbito, publica-se nesta edição um artigo de opinião do professor Manuel Azevedo, que faz uma reflexão sobre este problema enquadrando-o no contexto de pandemia que estamos a viver.*

*José Beleza Carvalho, Professor Doutor*

**Especial  
Dossier Telecomunicações  
Pág. 83**



**Máquinas e  
Veículos Elétricos**



**Produção, Transporte e  
Distribuição Energia**



**Instalações  
Elétricas**



**Telecomunicações**



**Segurança**



**Gestão de Energia e  
Eficiência Energética**



**Automação, Gestão  
Técnica e Domótica**

## ÍNDICE

- Editorial	3
- Será que ainda queremos um planeta verde? Manuel Maria Pereira de Azevedo	5
- Wind Energy Conversion Systems José António Beleza Carvalho	7
- Instalações Elétricas em Hospitais, Clínicas Privadas, Centros Médicos e Dentários, Centros de Tratamento e Similares Henrique Ribeiro da Silva	17
- Short-Circuit Calculation on a Small Network José Alberto de Sousa Afonso	53
- Rede de distribuição do Porto: interligação entre postos de transformação Miguel Alexandre Ferreira Alves Pereira	59
- Tratamentos sustentáveis e inovadores para a indústria da madeira Kevin Duarte Tomaz	69
- Case study of an energy-intensive consumer Inês Vieira Tavares	77
- Dossier Telecomunicações	83
- Autores	118

## FICHA TÉCNICA

DIRETOR:	José António Beleza Carvalho, Doutor
SUBDIRETORES:	António Augusto Araújo Gomes, Eng. Roque Filipe Mesquita Brandão, Doutor Sérgio Filipe Carvalho Ramos, Doutor
PROPRIEDADE:	Área de Máquinas e Instalações Elétricas Departamento de Engenharia Electrotécnica Instituto Superior de Engenharia do Porto
CONTATOS:	jbc@isep.ipp.pt ; aag@isep.ipp.pt

Estimados leitores

Num contexto mundial sem precedentes devido a uma pandemia que está a abalar o mundo, com consequências catastróficas nas economias de todos os países, voltamos à vossa presença com mais uma edição da revista “Neutro à Terra”, que já vai na sua vigésima quinta publicação. Compete-nos a todos agir com competência e responsabilidade, de forma a minimizar os efeitos devastadores que a situação atual terá na vida das pessoas. Neste contexto, as questões ambientais e a sustentabilidade energética tomam uma importância acrescida. Neste âmbito, publica-se nesta edição um artigo de opinião do professor Manuel Azevedo, que faz uma reflexão sobre este problema enquadrando-o no contexto de pandemia que estamos a viver

Nesta edição da revista publicam-se alguns artigos de natureza técnica e científica em língua inglesa, respondendo à crescente procura que se verifica por parte de leitores de várias nacionalidades. Por outro lado, também se pretende contribuir a nível internacional para o conhecimento e para a discussão de assuntos atuais e reconhecidamente importantes, como os que dizem respeito à sustentabilidade energética, às energias renováveis e, de uma forma geral, a todos os assuntos enquadrados cientificamente na engenharia eletrotécnica.

Merecem particular destaque nesta edição, um artigo relacionado com a conversão de energia eólica, analisando-se o funcionamento dos principais aerogeradores utilizados nesta fonte de energia renovável. Outro assunto muito importante relaciona-se com a proteção das pessoas do risco de eletrocussão com contactos diretos e indiretos em locais de risco elevado, como clínicas médicas e centros hospitalares. Neste âmbito, publica-se um artigo muito desenvolvido sobre as instalações elétricas nestes locais de risco, apresentando-se a forma como a segurança das pessoas deve ficar garantida.

Nesta edição da revista, merece ainda particular destaque um dossier sobre telecomunicações. Acompanhando a entrada em vigor do novo Manual ITED 4, que apresenta algumas soluções inovadoras e simplifica alguns dos procedimentos, com o objetivo de melhorar a eficiência e a adaptabilidade das infraestruturas de telecomunicações aos mais recentes desenvolvimentos tecnológicos, algumas Empresas que atuam nesta área da engenharia eletrotécnica apresentam algumas das soluções que disponibilizam no mercado, de forma a responderem às exigências técnicas definidas no Manual ITED4 que entrou recentemente em vigor.

Nesta edição da revista “Neutro à Terra” pode-se ainda encontrar outros assuntos reconhecidamente importantes e atuais, como um artigo que analisa o cálculo de correntes de curto-circuito em redes de distribuição de pequena dimensão, um artigo sobre tratamentos sustentáveis e inovadores para a indústria das madeiras e, um artigo que apresenta os resultados obtidos num estudo efetuado a um consumidor intensivo de energia.

Fazendo votos que esta edição da revista “Neutro à Terra” satisfaça novamente as habituais expectativas dos nossos estimados leitores, apresento os meus cordiais cumprimentos.

Porto, 30 de junho de 2020  
José António Beza Carvalho

Blog:

[www.neutroaterra.blogspot.com](http://www.neutroaterra.blogspot.com)

### Histórico de visualizações

**37 024**

Entrada	Visualizações de páginas
Portugal	27352
Estados Unidos	3209
Brasil	2114
Alemanha	686
Rússia	507
França	452
Angola	243
Ucrânia	225
Reino Unido	220
Espanha	141



## WIND ENERGY CONVERSION SYSTEMS

### 1 Introduction

The production of electricity from wind energy presents an increased growth and sustained since 1985. Currently, there are wind generators located throughout the world whose power already reaches values exceeding 250 GW.

The main technologies used in electromechanical conversion of wind energy into electric energy are based primarily on three types of electric machines:

- The direct current (DC) machine;
- The synchronous machine;
- The induction machine.

These machines work on the principles of the electromagnetic actions and reactions. The resulting electromechanical energy conversion is reversible. The same machine can be used as the motor for converting the electrical power into mechanical power, or as the generator converting the mechanical power into electrical power.

Typically, there is an outer stationary member (stator) and an inner rotating member (rotor). The rotor is mounted on bearings fixed to the stator. Both the stator and the rotor carry cylindrical iron cores, which are separated by an air gap. The cores are made of magnetic iron of high permeability, and have conductors embedded in slots distributed on the core surface. Other way, the conductors are wrapped in the coil form around salient magnetic poles.

In the Figure 1 is possible to see a cross-sectional view of the rotating electrical machine with the stator with salient poles and the rotor with distributed conductors. The magnetic flux, created by the excitation current in one of the two members, passes from one core to the other in the combined circuit always forming a closed loop. The electromechanical energy conversion is accomplished by interaction of the magnetic flux produced by one member with electric current in the other member.

The induced current is proportional to the rate of change in the flux linkage due to rotation.

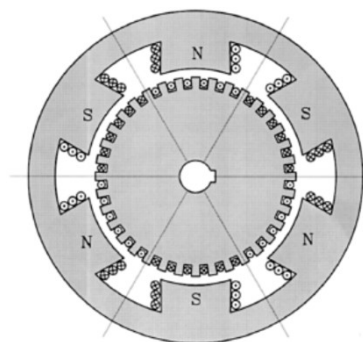

Figure 1: Cross section of the electrical machine stator and rotor

### 2. DC Machine

The conventional DC machine is either self-excited by shunt or series coils carrying DC current to produce a magnetic field. Actually, the DC machine is often designed with permanent magnets to eliminate the field current requirement, hence, the commutator. It is designed in the “inside-out” configuration. The rotor carries the permanent magnet poles and the stator carries the wound armature which produces AC current. This current is then rectified using the solid state rectifiers. Such machines do not need the commutator and the brushes; hence, the reliability is greatly improved. The permanent magnet DC machine is used with small wind turbines, however, due to limitation of the permanent magnet capacity and strength. The brushless DC machine is expected to be limited to ratings below one hundred kW.

### 3. Synchronous Machine

Most of the electrical power consumed in the world is generated by the synchronous generator. For this reason, the synchronous machine is an established machine.

The machine works at a constant speed related to the fixed frequency. Therefore, it is not suitable for variable-speed operation in the wind plants. Moreover, the synchronous machine requires DC current to excite the rotor field, which needs sliding carbon brushes on slip rings on the rotor shaft. This poses a limitation on its use. The need of DC field current and the brushes can be eliminated by the reluctance torque. The reliability is greatly improved while reducing the cost. The machine rating, however, is limited to tens of kW. The reluctance synchronous generator is actually used for small wind generators. In the Figure 2 is possible to see the diagram of connections of wind generators equipped with variable speed synchronous machines.

The systems represented in Figure 2, the synchronous machine is connected through a system of converting  $ac/dc/ac$ , as the frequency of stators voltage and currents is different in the frequency of the electrical network.

Such generators typically do not have the gearbox, and the mechanical speed of rotation of the rotor is identical to the speed of rotation of the turbine.

Typically, the speed of rotation of the turbine (and the rotor of synchronous machine) varies between 17 rpm and 36 rpm, so the machine has a high number of poles.

The stator of the synchronous machine has six phases and is connected to two independent converting systems  $ac/dc/ac$ . The parallel between the two conversion systems is made at the outlet of converters  $dc/ac$  (grid converters) that is connected to the elevator transformer.

Each of the converters  $ac/dc$  connected to the generator (the generator converters) consists of one to six pulse bridge converter equipped with thyristors. These thyristors operate with a constant firing angle.

The DC voltage at capacitor terminals, placed in parallel in connection at direct current, must be set to a constant value. However, for low values of the speed of the rotor, the excitation system of synchronous machine is unable to ensure that value, being necessary to use a "chopper" (converter  $dc/dc$ ) converter installed between the generator and capacitor, which is disconnected when the rotor speed exceeds a certain value.

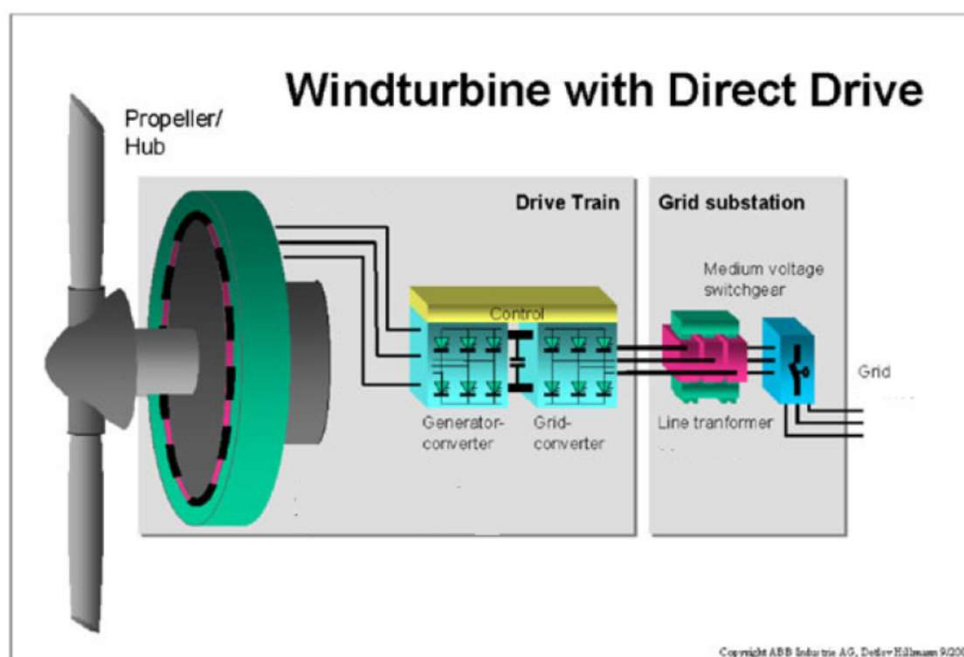

Figure 2: Diagram of connections of a synchronous generator operating the variable speed (Source: ABB Industries)

The grid converter is a six pulse converter bridge equipped with IGBTs, with a control system based in pulse width modulation (PWM). This converter controls the active power injected into the grid and the power factor. The control of active power in the grid converter allows the imposition of electromagnetic torque into generator, thus making it possible to control the rotational speed of the wind turbine-generator group in order to obtain the specific speed of the tip of the blade optimal (2) for each value of wind speed.

Figure 3 illustrates the active and reactive power supplied by the grid converter of such a wind generator according to the rotational speed of the rotor.

Unlike the induction machine, the synchronous machine, when used in the grid-connected system, has some advantages. It does not require the reactive power from the grid. This results in better quality of power at the grid interface. This advantage is more important when the wind farm is connected to a small capacity grid using long low voltage lines. Actually, wind plants generally connect to larger grids using shorter lines, and almost universally use the induction generator.

#### 4. Induction Machine

The primary advantage of the induction machine is the rugged brushless construction and no need for separate DC filed power.

The disadvantages of both the DC machine and the synchronous machine are eliminated in the induction machine, resulting in low capital cost, low maintenance, and better transient performance. For these reasons, the induction generator is extensively used in small and large wind farms and small hydroelectric power plants. The machine is available in numerous power ratings up to several megawatts capacity, and even larger.

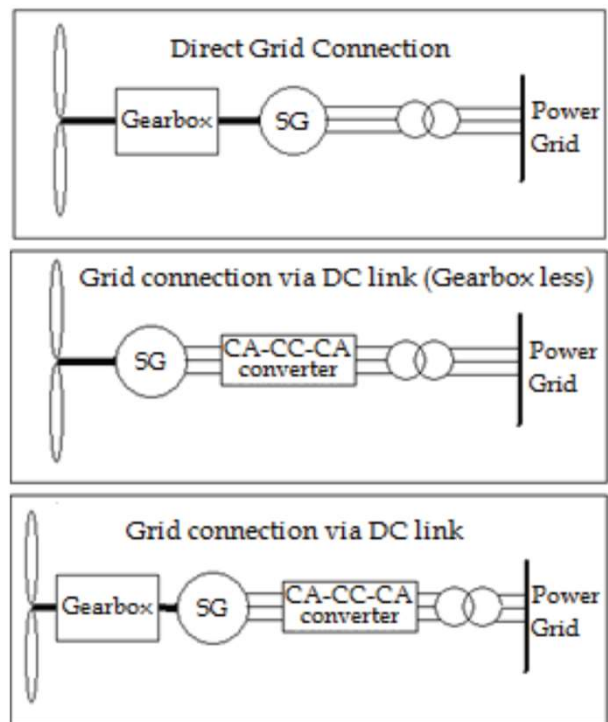

Figure 4: Settings of synchronous machine used as a wind generator (CIGRE TF38.01.10)

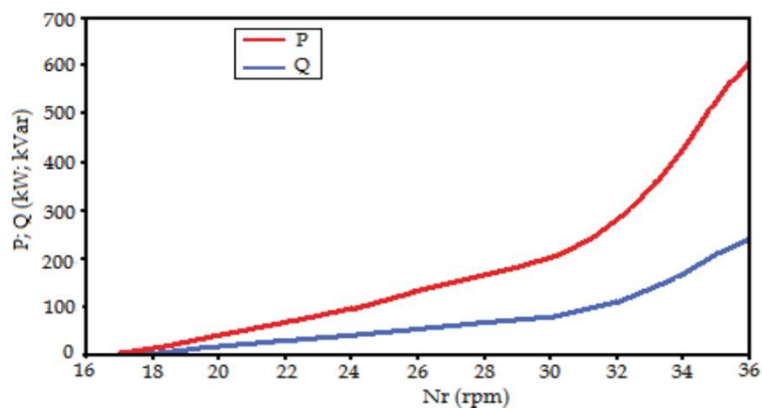

Figure 3: Active and reactive power supplied by a wind generator equipped with synchronous generator operates the variable speed depending on the speed of the rotor.

The induction machine needs AC excitation current. The machine is either self-excited or externally excited. Since the excitation current is mainly reactive, a stand-alone system is self-excited by shunt capacitors. The induction generator connected to the grid draws the excitation power from the network. The synchronous generators connected to the network must be capable of supplying this reactive power. For economy and reliability, many wind power systems use induction machines as the electrical generator.

#### - Operation of the Induction Generator in Autonomous Mode

The induction machine to function as a generator must be operated at a speed above the synchronous speed and to be provided with a reactive power to produce and keep the machine's magnetic field. This reactive power can be produced by capacitors connected to the machine, as described in Figure 5. Thus it is possible to achieve self-excitation of the machine in order to feed a load alone.

The capacitors are usually connected in delta because they have the advantage of lower capacity to get the same effect as with capacitors connected in star. Thus, the voltage  $V_1$  and the frequency  $f_1$  of the generators of induction in empty and laden depend primarily on parameters of the machine, the capacity of condensers and speed  $n > f_1/p$ .

The existence of residual magnetism in the machine, with the machine to turn, will result in the emergence of power swing in the machine between the stator coils and condensers.

Indeed, the coils of inductance  $L$  and the capacity  $C$  of the capacitors are an oscillating circuit and therefore fluctuations of energy may be damped or amplified.

If the rotor rotates with angular velocity  $\omega_r$  whose frequency is higher than the frequency of own oscillations (given by  $1/\sqrt{LC}$ ) then the power of the rotor copper losses in the oscillating circuit and the machine turns on. If, however there is no residual magnetism or if this is not enough, the oscillations do not occur or cushion quickly and the machine not exciting.

The operating voltage and frequency are determined in terms of the approximate equivalent circuit of Figure 5. On no load, the capacitor current  $I_c = V_1/X_c$  must be equal to the magnetizing current  $I_m = V_1/X_m$ . The voltage  $V_1$  is a function of  $I_m$ , linearly rising the saturation point of the magnetic core is reached (Figure 5). The stable operation requires the line  $I_m X_c$  to intersect the  $V_1$  versus  $I_m$  curve.

The operating point is fixed where  $V_1/X_c$  equal  $V_1/X_m$ , that is when  $1/X_c = 1/X_m$ , where  $X_c = 1/\omega C$ . This settles the operating frequency in hertz. With the capacitor value  $C$ , the output frequency of the self-excited generator is therefore:

$$f = \frac{1}{2\pi X_m} = \frac{1}{2\pi \sqrt{C L_m}}$$

Under load conditions, the generated power  $V_1 I_2 \cos \phi_2$  provides for the power in the load resistance  $R$  and the iron loss in  $R_m$ . The reactive currents must sum to zero:

$$\frac{V_1}{X} + \frac{V_1}{X_m} + I_2 \cdot \sin \phi_2 = \frac{V_1}{X_c}$$

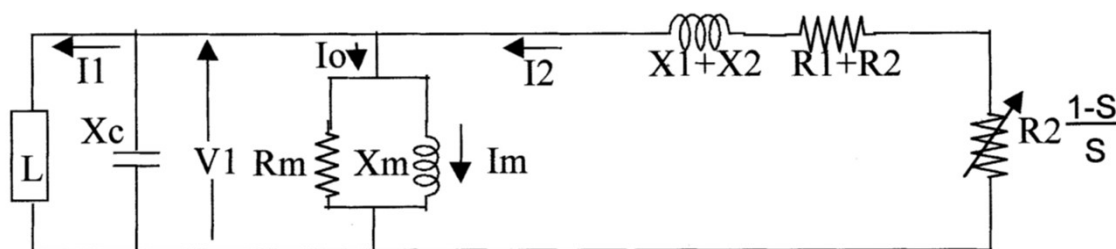

Figure 5: Approximate equivalent scheme of an induction generator for autonomous load



This equation determines the output voltage of the machine under load.

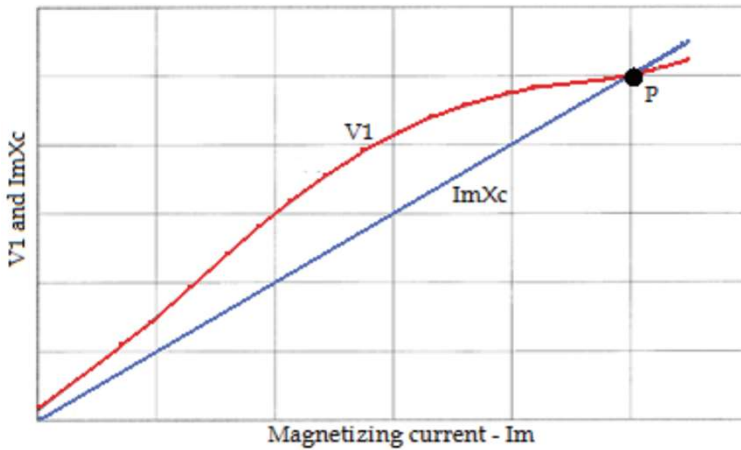

Figure 6: Operating characteristics of the induction generator with capacitive self-excitation.

As it possible to see in Figure 6, the process of self-excitation requires the presence of a residual magnetism and magnetic saturation of the magnetization curve of the machine to be successful, or to have a clear intersection between the two characteristics (of magnetization and strain in capacitors).

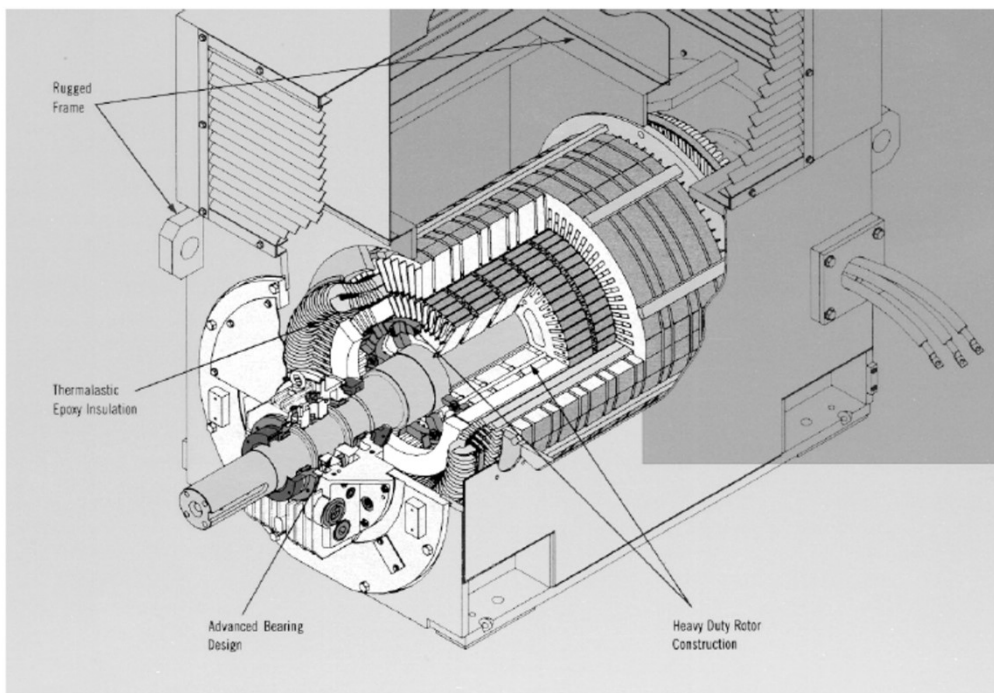

Figure 7: Two MW induction machine. (Source: Teco Westinghouse Motor Company)

- **Operation of the induction generator connected to the network**

The electromagnetic power through the air gap is given by:

$$P_{em} = 3I_2^2 \cdot \frac{R_2}{s}$$

is positive for  $s > 0$  and negative for  $s < 0$ .

That is, for  $s < 0$  the electromagnetic power flow at rotor to the stator. Part of this power is dissipated (by Joule effect) in the copper winding of the stator and the remainder is supplied to the network. This corresponds to the operation of the machine as a generator (Figure 8).

In this case, the machine must be operated at a speed  $n > f_1/p$  and both the power and the electromagnetic torque are negative.

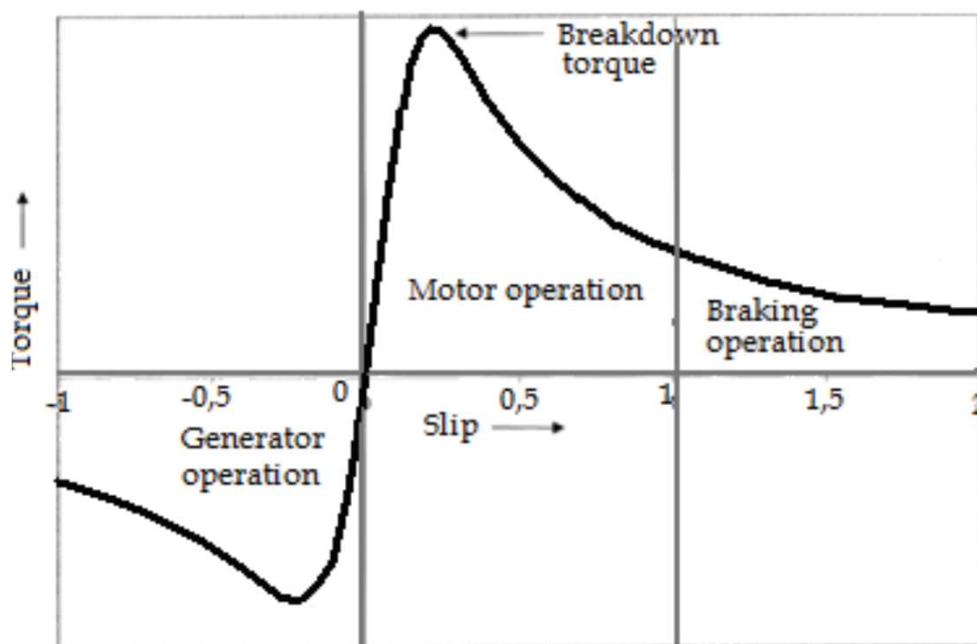

Figure 8: Torque versus speed characteristic of the induction machine in three operating modes.

When assessing the performance of induction generator, we can use the approximate equivalent diagram of Figure 5 with  $s < 0$ . The resistance that  $((1-s) / s) R_2$ , which reflects the electromagnetic power, depends on the slip, but the reactance  $X$  does not depend on the slip, or are always positive. Consequently, the induction machine always absorbs reactive power in whatever condition of operation. How is possible to see in Figure 9, if the generator is loaded at constant torque  $T_L$ , it has two possible points of operation, P1 and P2.

Only one of these two points, P1 is stable. Any perturbation in speed around point P1 will produce stabilizing torque to bring it back to P1.

The figure also shows the limit to which the generator can be loaded. The maximum torque it can support is called the breakdown torque, which is shown as  $T_{max}$ . If the generator is loaded under a constant torque above  $T_{max}$ , it will become unstable and stall, draw excessive current, and destroy itself thermally if not properly protected.

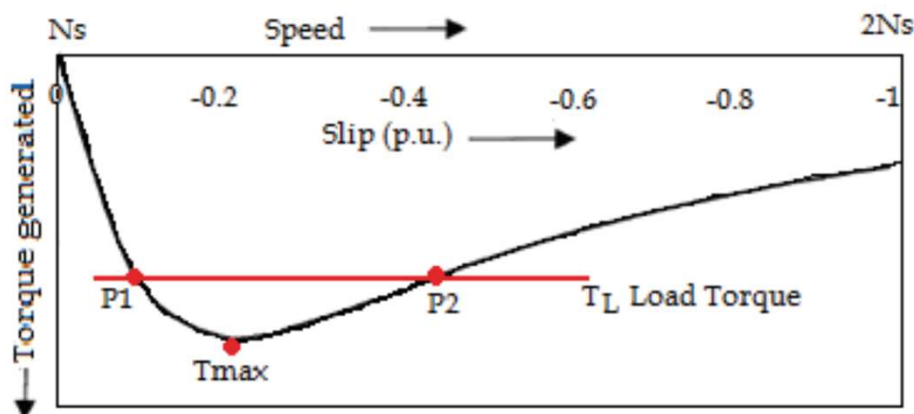

Figure 9: Torque versus speed characteristic of the induction generator under load.

- Usual Configuration of the Induction Generator

The induction generators connected to the network or in autonomous mode are mainly used, for constant or variable speeds and a link voltage/constant or variable frequency, in mini-hydro and wind energy systems. Possibilities for the use of double fed induction generators and the squirrel cage rotor are summarized in Table 1.

The principle of operation of the double fed induction machine is based on the ability to control its speed by variation of the resistance of the rotor.

Figure 10 illustrates the change curves of torque/slip of the induction machine due to the variation of resistance connected in series with the winding rotor.

Table 1: Configuration of the Induction Generators

Induction generator	speed		Network connection	Isolated	Frequency		Voltage	
	Constant	Variable			Constant	Variable	Constant	Variable
Double Fed		X	X		X		X	
Squirrel Cage	X	X	X	X	X	X	X	X

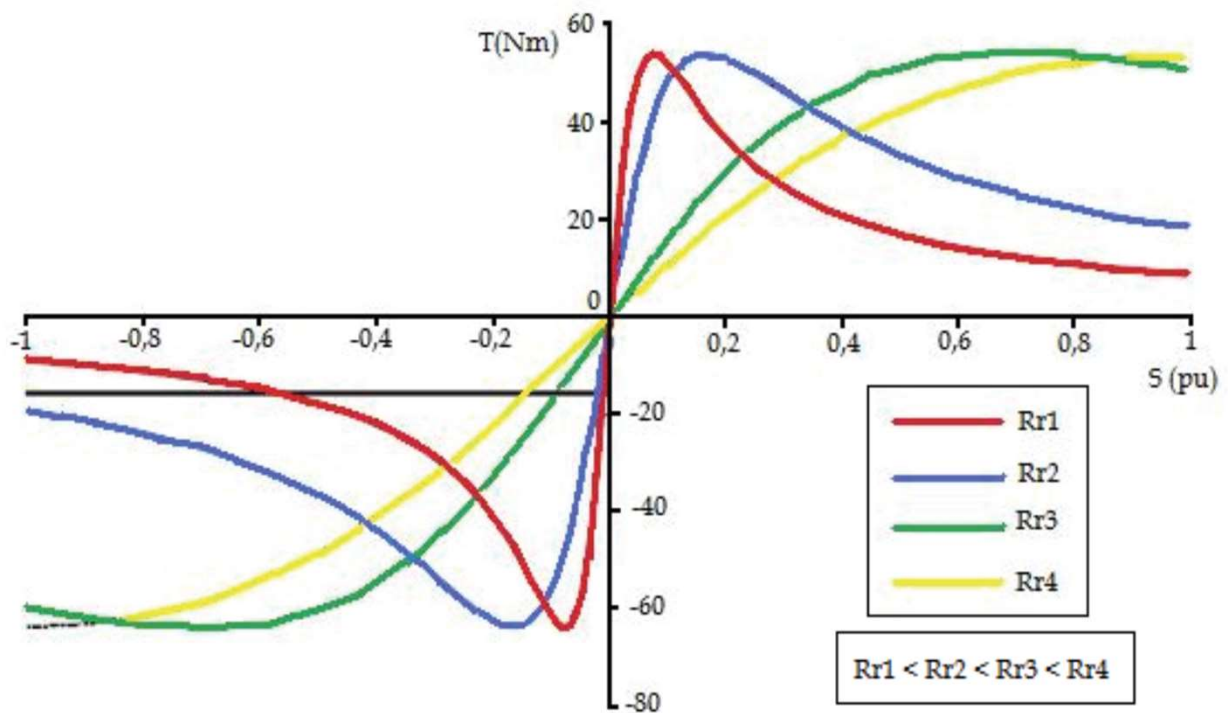

Figure 10: Curves of torque-speed characteristics for different values of the resistance of the rotor.

As shown in the figure 10, for a given mechanical torque  $T$ , can vary the speed of induction machine by varying the rotor resistance. If instead of a variable resistance, if we install a system for converting ac/dc/ac connected to the rotor, it is possible to extract the active power by the rotor of the machine and thus control the speed. This is the principle of energy away from the winding rotor induction machine.

The mode of operation of double fed induction generators based on the principle described above: to negative slips, until it reaches the intensity of the stator rated current of the machine, the power extracted by the rotor of the machine is controlled so as to optimize the speed specified the tip of the blade of the rotor and thereby maximize the value of the coefficient of the power turbine.

For negative slips, higher (in modulus) for which the intensity of the stator current reaches the nominal value, the active power in the stator and the rotor remains constant.

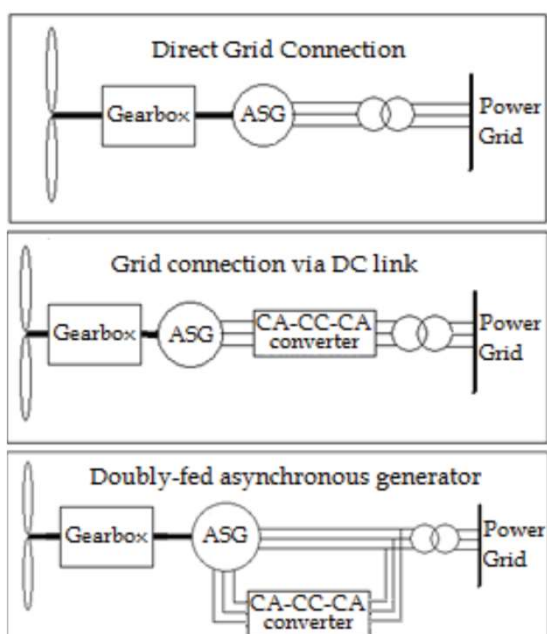

Figure 11: Settings of induction machine used as a wind generator (CIGRE TF38.01.10)

This principle of speed control by use the slip energy means that this machine can function as a generator for positive slip. To ensure this mode of operation, it is necessary to provide active power to the rotor. In Figure 11 we can see different ways to use the induction machine as wind generator.

The connections of double fed induction machine are shown in Figure 12.

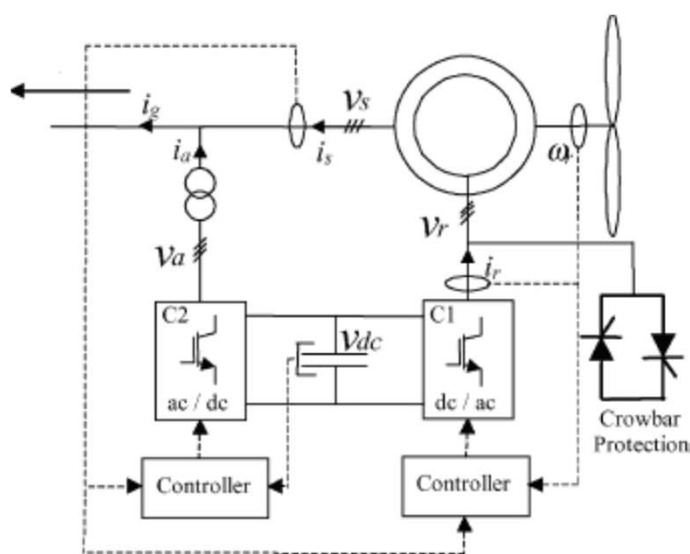

Figure 12: Scheme of connections of double fed induction machine (Almeida et al.,2004).

The stator of the induction machine is directly connected to electric power. The rotor is connected to the network through a system of converting ac/dc/ac and a transformer.

The converters ac/dc/ac that interconnect the rotor of the machine to the network via the transformer, are bridge-type converters PD3 to six pulses equipped with isolated gate bipolar transistors (IGBTs) controlled by the pulse width modulation.

Typically, in double fed induction machine, converter connected to transformer controls the voltage into the terminals of the capacitor in DC current system, and controls the power factor at the point common to the circuits of the rotor and stator. The converter directly connected to the rotor of the induction machine control module and the argument of the intensity of current injected or extracted through the rotor.

The principle of operation of the control system with pulse width modulation can impose a form of wave approximately sinusoidal with frequency, amplitude and phase adjustable to the AC terminals of the converters.

In Figure 12, the converter ac/cc/ac connected to the rotor of the induction machine, allows the control of the frequency of the wave form applied to the rotor, which is equal to the slip frequency of the machine in a given point. Simultaneously, it also controls the module and argument of the intensity of current in the rotor. Converter ac/cc on the transformer, is controlled the magnitude of the voltage into the terminals of the capacitor. The frequency of the alternating current frequency is equal to the network with which the converter is interconnected and the control of the phase allows impose the power factor. This feature of the control system of pulse width modulation to adjust the phase of the wave of voltage and intensity of current wave can dispense the use of batteries of capacitors in most cases.

Typically, manufacturers provide a control of power factor between 0.9 inductive and 0.9 capacitive to terminal of the machine.

The purpose of the control system of converters ac/cc/ac is to ensure the maximization of the coefficient of the turbine power, especially in the region characteristic of the power depending on the wind and where the power is not controlled.

Additionally, the control systems of converters maintain a given value of power factor at the point of interconnection of the doubly fed induction machine with the electric power grid. In region of characteristic where the turbine power is controlled, the control system of converters ac/cc/ac keeps constant the total power, extracted by the stator and rotor of the machine, complemented by the control system of step angle of the rotor blades. It is therefore concluded that the control system of wind generators equipped with double fed induction machine can maximize the electrical power delivered to the network in the range of variation of wind speed.

## 5. References

- [1] Almeida, R. G.; Peças Lopes, J. A. & Barreiros, J. A. L. Improving Power System Dynamic Behaviour Through Doubly Fed Induction Machines Controlled by Static Converter Using Fuzzy Control. IEEE Transactions on Power Systems, Vol.19, No.4, (November 2004) pp. 1942-1950.
- [2] Ekanayake, J. B.; Holdsworth, L.; Wu, X. & Jenkins, N. Dynamic Modeling of Doubly Fed Induction Generator Wind Turbines. IEEE Transactions on Power Systems, Vol.18, No.2, (May 2003) pp. 803-809.
- [3] Castro, R. Uma Introdução às Energias Renováveis: Eólica, Fotovoltaica e Mini-Hídrica. 2ª Edição. IST PRESS, 2016.
- [4] Brandão, R.M.; Carvalho, J.B. & Barbosa, F.P.M. Wind Energy Technology. Renewable Energy 2009-In-tech, pp. 505-530.

### Decreto-Lei n.º 162/2019, de 25 de outubro

#### Objeto

- 1 - Estabelece o regime jurídico aplicável ao autoconsumo de energia renovável, estabelecendo a disciplina da atividade de produção associada às instalações de utilização do autoconsumidor de energia renovável.
- 2 - Estabelece, igualmente, o regime jurídico das comunidades de energia renovável, procedendo, nesta parte, à transposição parcial para o direito interno da Diretiva 2018/2001 do Parlamento Europeu e do Conselho, de 11 de dezembro de 2018, relativa à promoção da utilização de energia de fontes renováveis.

**Título:** Instalações Elétricas de Baixa Tensão: Dimensionamento e Proteção de Canalizações Elétricas  
2ª Edição

**Autor:** António Augusto Araújo Gomes, Henrique Jorge de Jesus Ribeiro da Silva, José António Beleza Carvalho

**Editora:** Engebook

**Data de Edição:** 2019

**ISBN:** 9789898927620

**Nº Páginas:** 202

**Sinopse:**

Esta obra pretende ser, acima de tudo, uma ferramenta didática de apoio aos alunos de cursos de engenharia eletrotécnica, bem como a técnicos responsáveis pelo projeto, execução e exploração de instalações elétricas.

Pretende ser ainda uma ferramenta prática de estudo e de trabalho, capaz de transmitir conhecimentos técnicos, normativos e regulamentares sobre o dimensionamento e proteção de canalizações elétricas aos diversos agentes eletrotécnicos, tornando-os capazes de, para cada instalação nas quais sejam intervenientes, seleccionar o tipo de canalização e o modo de instalação mais adequados, de forma a maximizar a segurança, a fiabilidade e a funcionalidade, assim como os custos de execução e exploração das instalações.

**INSTALAÇÕES ELÉTRICAS DE BAIXA TENSÃO**  
DIMENSIONAMENTO E PROTEÇÃO DE CANALIZAÇÕES ELÉTRICAS

António Gomes, Henrique Ribeiro Da Silva, José Beleza Carvalho

**Sobre a obra**

Esta obra pretende ser, acima de tudo, uma ferramenta didática de apoio aos alunos de cursos de engenharia eletrotécnica, bem como a técnicos responsáveis pelo projeto, execução e exploração de instalações elétricas. Pretende ser ainda uma ferramenta prática de estudo e de trabalho, capaz de transmitir conhecimentos técnicos, normativos e regulamentares sobre o dimensionamento e proteção de canalizações elétricas aos diversos agentes eletrotécnicos, tornando-os capazes de, para cada instalação nas quais sejam intervenientes, seleccionar o tipo de canalização e o modo de instalação mais adequados, de forma a maximizar a segurança, a fiabilidade e a funcionalidade, assim como os custos de execução e exploração das instalações.

**Sobre os autores**

**António Augusto Araújo Gomes**

Bacharel em Engenharia Eletrotécnica – Sistemas de Energia pelo Instituto Superior de Engenharia do Porto. Licenciado e Mestre (pre-doutor) em Engenharia Eletrotécnica e Computadores pela Faculdade de Engenharia da Universidade do Porto. Professor adjunto no Departamento de Engenharia Eletrotécnica do Instituto Superior de Engenharia do Porto desde 1998. Coordenador de Cursos na CEREBELUS – Engenharia de Segurança, entre 1997 e 1999. Sócio da empresa Neutro à Terra – Gabinete de Engenharia Ltda C252 e 2000. Prestação de serviços de formação profissional em áreas relacionadas com o ambiente das instalações elétricas, telecomunicações, segurança, gestão de energia, eficiência energética e diversos entalhos, nomeadamente NORVA – Consultores de Engenharia, Lda; Schumal – Engenharia e Serviços, Lda; ENERGO – Consultores de Engenharia, Lda; IQE – Instituto de Qualidade e Qualidade Quântica – fábrica de Quilómetros, Lda; EP – Instituto Eletrotécnico Português; CENEFEEZ – Centro de Energia e Tecnologia; ANACOM – Autoridade Nacional das Telecomunicações; ICT – Instituto para o Desenvolvimento Tecnológico; EDV – Agência de Energia Entre Douro e Vouga.

**Henrique Jorge de Jesus Ribeiro da Silva**

Licenciado em Engenharia Eletrotécnica, ramo de Produção, Transporte e Distribuição de energia, pela Faculdade de Engenharia da Universidade do Porto e Mestre (pre-doutor) em Engenharia Industrial pela Escola de Engenharia da Universidade do Minho. Professor Adjunto no Departamento de Engenharia Eletrotécnica do Instituto Superior de Engenharia do Porto.

**José António Beleza Carvalho**

Bacharel e Licenciado em Engenharia Eletrotécnica pelo Instituto Superior de Engenharia do Porto. Mestre e Doutor em Engenharia Eletrotécnica na especialidade de Sistemas de Energia pela Faculdade de Engenharia da Universidade do Porto. Professor Coordenador no Departamento de Engenharia Eletrotécnica do Instituto Superior de Engenharia do Porto, desempenhando atualmente as funções de Diretor do curso de Mestrado em Sistemas Eléctricos de Energia. É autor de vários artigos publicados em conferências nacionais e internacionais, diretor da revista neutro à terra e integrou vários júris de provas públicas de doutoramento e para a carreira do ensino superior.

Apoio à Edição  
**hager**

Parceiro de Comunicação  
**electricista**

Também disponível em formato e-book  
ISBN 9789898927620  
www.engebook.pt

**engebook**



**INSTALAÇÕES ELÉTRICAS DE BAIXA TENSÃO**  
DIMENSIONAMENTO E PROTEÇÃO DE CANALIZAÇÕES ELÉTRICAS

ENGEBOOK **ELEKTROTECNIA**

António Gomes  
Henrique Ribeiro Da Silva  
José Beleza Carvalho

**2ª EDIÇÃO**



**engebook**