

Simultaneous multiple surface method for the design of new parabolic dish-type concentrator using a Cassegranian approach

Cite as: AIP Conference Proceedings **2126**, 050001 (2019); <https://doi.org/10.1063/1.5117584>
Published Online: 26 July 2019

Diogo Canavarro, Julio Chaves, and Manuel Collares-Pereira



View Online



Export Citation

ARTICLES YOU MAY BE INTERESTED IN

[On-site parabolic-trough collector characterization in solar district heating plant under quasi-dynamic conditions](#)

AIP Conference Proceedings **2126**, 120018 (2019); <https://doi.org/10.1063/1.5117636>

[A novel quasi-stationary CPC-type solar collector for intermediate temperature range applications for process heat: Simulation and experimental results](#)

AIP Conference Proceedings **2126**, 150006 (2019); <https://doi.org/10.1063/1.5117662>

[Two-way fluid-structure interaction of medium-sized heliostats](#)

AIP Conference Proceedings **2126**, 030064 (2019); <https://doi.org/10.1063/1.5117576>



Your Qubits. Measured.

Meet the next generation of quantum analyzers

- Readout for up to 64 qubits
- Operation at up to 8.5 GHz, mixer-calibration-free
- Signal optimization with minimal latency

[Find out more](#)



Simultaneous Multiple Surface Method for the Design of New Parabolic Dish-type Concentrator Using a Cassegranian Approach

Diogo Canavarro^{1, a)}, Julio Chaves² and Manuel Collares-Pereira³

¹PhD., Renewable Energies Chair, University of Évora, Palácio do Vimioso, Largo Marquês de Marialva Apart. 94, 7002-554 Évora, Portugal, (+351)740 800 (ext. 54321)

²PhD., Limbak, Edificio Cedint, Campus de Montegancedo UPM, 28223 Pozuelo de Alarcón, Madrid, Spain.

³Professor-PhD., Renewable Energies Chair, University of Évora, Palácio do Vimioso, Largo Marquês de Marialva Apart. 94, 7002-554 Évora, Portugal, (+351)740 800 (ext. 54309)

^{a)}Corresponding author: diogocvr@uevora.pt

Abstract. Parabolic Dish concentrators are a well-known solution for many applications such as Concentrated Solar Power (CSP), solar metallurgical processes, solar reactors for fuel production, etc. Nevertheless, this technology is facing a tremendous challenge to become more efficient and competitive (especially within CSP field) in comparison with other technologies, namely Central Tower Receivers. A possible path to achieve this goal is to use a Cassegranian approach which enables a top-down design, placing the receiver closer to the ground and with potential higher concentration. In this paper, the theoretical limit of such configurations and a practical solution is presented with a discussion of its advantages and possible drawbacks.

INTRODUCTION

Parabolic Dish (PD) concentrators belong to the so-called point-focus or 3D systems, having much higher concentration factor than the line-focus or 2D systems such as Linear Fresnel Reflectors (LFR) and Parabolic Troughs (PT). In fact, the maximum possible concentration for 3D systems is given by [1,2]:

$$C_{3D} = \frac{n^2}{\sin^2 \theta} \quad (1)$$

Where n is the refractive index in which the receiver is immersed and θ is the half-acceptance angle of the concentrator. Usually $n=1$ (receiver is immersed in air or vacuum) and considering that the angular radius of the sun is $\theta_{\text{sun}} = 4.7$ mrad [3], the maximum concentration for such systems is about 45300X. In practice these systems have a much lower concentration factor to be able to accommodate several optical errors such as manufacturing tolerances, tracking deviations, etc. PD concentrators have been mainly used in Concentrated Solar Power (CSP) field coupling the system with a Stirling engine [4,5,6]. Nevertheless, this technology has been facing a tremendous challenge during the recent years, especially within the CSP field, to stay as a viable option in view of other potential lower-cost possibilities such as LFR, PT and Central Tower Receiver (CTR), although their global solar to electricity efficiency conversion being usually higher. Plus, these system are nowadays not competitive at all in comparison with CPV (Concentrated PhotoVoltaics) system which usually also use point-focus technologies. Moreover, PD also have some technical problems namely:

- The Stirling engine is usually big due to the size of its radiators inducing shading losses over the primary mirror;
- The position of the Stirling engine on the focus of the concentrator demands a very strong structural architecture to hold it. This induces mechanical problems related to the tracking mechanism, wind induced deviations, etc.;
- Due to its focusing approach these concentrators tend to create a non-uniform light distribution on the receiver. This creates hot-spots (peak irradiance zone) hence increasing the chances of having mechanical and thermal problems associated to it;
- PD concentrators fall short from the theoretical limits of concentration (see Eq. 1) which penalizes their overall efficiency.

In order to overcome some of these technical difficulties, the Cassegrain approach has already been proposed as an alternative configuration but essentially for CTR systems [7,8,9], although there are already some proposals for market penetration for PD concentrators [10]. In this approach the receiver is placed near or below the center of the heliostat center and the focus is replaced by a secondary mirror to bring the light down, as schematically shown in Fig. 1. Although this does not eliminate the need of having structural supports for the secondary mirror, the fact the receiver is placed near the ground might facilitate the installation, operation and maintenance of the system. Moreover, the Stirling engine is placed behind the heliostat mirror which not only does not shades it but it can also be bigger for better efficiency conversions.

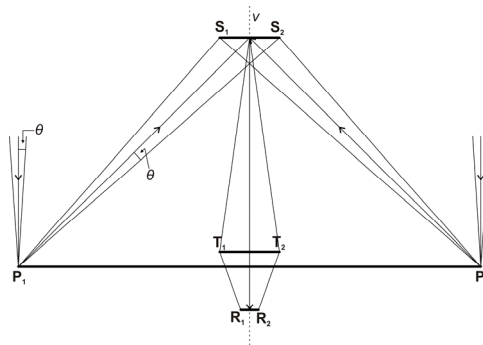

FIGURE 1. Schematic representation of the Cassegrainian approach.

This approach implies, however, the use of several optical stages through which the light passes through towards the receiver (see Fig. 1). Regardless the optical elements chosen for the concentrator (mirror, lens, etc.) to redirect the light beam, it is necessary to guarantee that the dimensions of each stage are properly selected in order to ensure maximum efficiency and concentration. This can be done through the conservation of etendue [1,2] throughout all the optical stages. Conservation of etendue implies conservation of energy and, therefore, maximum efficiency. This condition is the guideline to establish the physical (geometrical) limits of any configuration, as shall be seen next.

On the other hand, in order to reach maximum concentration it is necessary to properly design all the optical elements that compose the concentrator. This can be done using the tools from Non-imaging Optics, in particular the Edge-Ray principle [1,2]. These devices have proven the potential for high concentration and high efficient energy production and were successfully applied for LFR and PT concentrators in the recent past [11,12,13,14].

In summary, the present paper is organized as follows: in Section 2 the optical limits of Cassegrain approach are presented. Section 3 shows an example of an optical configuration using parabolic dish-type concentrators and lens aimed to reach the maximum concentration. Section 4 shows a practical configuration and some expected

performance results using a raytracing technique. Finally, in Section 5 some conclusions and perspectives for the future are also discussed.

THE OPTICAL LIMITS OF CASSEGRANIAN APPROACH

Revision of Etendue Concept

As light travels through an optical system (e.g., a solar concentrator) it requires area and angular space (see Fig.2). These two “rooms” define a geometric quantity known as etendue. For 2D systems, the etendue U_{2D} is given by [1]:

$$U_{2D} = 2na \sin \theta \quad (2)$$

Which is the etendue of the radiation crossing the length a immersed in a refractive index n within an angle $\pm\theta$. For 3D systems the etendue, U_{3D} , is given by:

$$U_{3D} = 2n^2 a (\sin \theta)^2 \quad (3)$$

Where a now is the area of the entrance of the optical system.

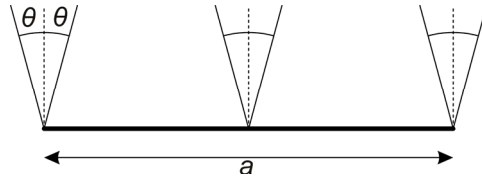

FIGURE 2. Etendue of the radiation crossing the length a within an angle $\pm\theta$.

In practice, usually $n=1$ (and it shall be used for all the calculations presented in this paper) and θ is chosen through Eq.(1) by selecting a desired concentration factor. This quantity must remain constant throughout the whole optical system to achieve maximum concentration.

Etendue-Coupling

Let us consider again the schematic representation of the Cassegrain approach shown in Fig. 1. The light hits the primary P_1P_2 and it is reflected towards the secondary S_1S_2 . Then the light is reflected towards the terceary T_1T_2 and finally collected by the receiver R_1R_2 . The inclusion of the terceary is related to the fact that without it the distance between the secondary and the receiver (which can be seen as an optical channel) would be very large, considerably increasing the size of the first hence increasing the shading losses. Plus, the size of the receiver “seen” from the secondary would be very short hence decreasing the acceptance-angle (penalizing the overall CAP - Concentration-Acceptance Product [11]). Due to these reasons, it is necessary to introduce an intermediate optical channel between the secondary and the receiver and that is why the terceary stage is included.

The first step is to set the proper dimensions of each stage through which the light passes. This can be done using an etendue-coupling between all the stages using the Hottel’s string method [1]. Note that, although the final configuration is a 3D-optic, the design and optimization can be done in 2D since the final solutions can be achieved by rotation symmetry. Suppose then the positions of P_1P_2 are known as well as the half-acceptance angle θ . The etendue reaching P_1P_2 , $U_{P_1P_2}$, is then given by:

$$U_{P_1P_2} = 2[\mathbf{P}_1, \mathbf{P}_2] \sin \theta \quad (4)$$

Where $[\mathbf{A}, \mathbf{B}]$ represents the Euclidean distance between two points \mathbf{A} and \mathbf{B} .

This etendue must remain constant throughout all the optical stages in order to reach maximum concentration. Let us consider now that $\mathbf{P}_1\mathbf{P}_2$ is a Lambertian source fully illuminating $\mathbf{S}_1\mathbf{S}_2$, i.e., each point between \mathbf{P}_1 and \mathbf{P}_2 fully illuminates the secondary. Consider also that $\mathbf{S}_1\mathbf{S}_2$ also fully illuminates the tertiary $\mathbf{T}_1\mathbf{T}_2$ and that there are no optical elements connecting both. The etendue exchanged between $\mathbf{S}_1\mathbf{S}_2$ and $\mathbf{T}_1\mathbf{T}_2$, $U_{S_1S_2-T_1T_2}$, is given by Hottel's string method:

$$U_{S_1S_2-T_1T_2} = [\mathbf{S}_1, \mathbf{T}_2] + [\mathbf{S}_2, \mathbf{T}_1] - [\mathbf{S}_1, \mathbf{T}_1] - [\mathbf{S}_2, \mathbf{T}_2] \quad (5)$$

In order to conserve the etendue $U_{P_1P_2} = U_{S_1S_2-T_1T_2}$. Since the system is symmetric with respect to the vertical line v , points \mathbf{S}_2 and \mathbf{T}_2 are the symmetric of \mathbf{S}_1 and \mathbf{T}_1 , respectively. To get the solution one can, for instance, force a certain height for points \mathbf{S}_1 and \mathbf{T}_1 (the 'y' component) relatively to $\mathbf{P}_1\mathbf{P}_2$ and find the appropriated width (the 'x' component) which fits the conservation of the etendue.

The similar process can now be applied to find the dimensions and position of the receiver $\mathbf{R}_1\mathbf{R}_2$. Again, consider that the tertiary $\mathbf{T}_1\mathbf{T}_2$ fully illuminates the receiver and that there are no optical elements connecting both. The etendue exchanged between $\mathbf{T}_1\mathbf{T}_2$ and $\mathbf{R}_1\mathbf{R}_2$, $U_{T_1T_2-R_1R_2}$, is given by:

$$U_{T_1T_2-R_1R_2} = [\mathbf{T}_2, \mathbf{R}_1] + [\mathbf{T}_1, \mathbf{R}_2] - [\mathbf{T}_1, \mathbf{R}_1] - [\mathbf{T}_2, \mathbf{R}_2] \quad (6)$$

And $U_{P_1P_2} = U_{S_1S_2-T_1T_2} = U_{T_1T_2-R_1R_2}$ is now enough to find the position of points \mathbf{R}_1 and \mathbf{R}_2 .

It is of course possible to add more optical stages to reduce the distance between them. This has the advantage of reducing the size of each optical component but the drawback of increasing the complexity of the system. Nevertheless, the process is still the same by using the conservation of the etendue.

Now each optical stage must be replaced by optical components (mirrors or lens) and in the next chapter some examples will be shown. Nevertheless, it is important to point out that regardless the optical configuration chosen the dimensions of the system are imposed and limited by the conservation of the etendue, using the method of calculation presented above.

A SIMULTANEOUS MULTIPLE SURFACE CONCENTRATOR USING A CASSEGRANIAN APPROACH

As mentioned in the Introduction, once the dimensions of the system are well defined it is necessary to properly design the optical components in order to reach the maximum concentration. In this chapter, a solution based on the Simultaneous Multiple Surface (SMS) [15] method is presented and it can be seen as a standard solution for the present configuration. The SMS is regarded as one of the most powerful design techniques available and it was successfully used by the authors in other applications for PT and LFR like concentrators [11,12,13,14].

The optical elements can be reflective (X), refractive (R) or use Total Internal Reflection (I). In the present case, a XXRR SMS concentrator was chosen, corresponding to a reflective primary and secondary and a lens (double refraction) as a tertiary. The reflective and refractive components can be design separately and for sake of better understanding they will be shown in the next sub-chapters

XX SMS Optic Design

The XX SMS design (primary and secondary designed simultaneously) follows a similar method presented in a previous work [11] and it is shown in Fig. 3. Since the concentrator is symmetrical with respect to the vertical line v ,

we may design only half of it. We start by defining the flat wave fronts w_1 and w_2 , tilted by angles $\pm\theta$ to the horizontal, representing the edges of the source (which is considered to be placed at infinite distance). Now one must define the ray assignment as well as the optical path lengths [1,2] which will be used to design both the primary and secondary mirrors. The design of the mirrors starts with surfaces p_1 and s_1 representing, respectively, a parabola tilted by an angle $\pi/2\pm\theta$ relatively to the x_1 axis and focus at S_2 and an ellipse with focus at P_2 and T_1 that goes through point S_2 . According to the Edge-Ray Principle in order to achieve the maximum possible concentration the edge rays coming from the edges of the source (wave fronts w_1 and w_2) must be redirected towards the edges of the receiver (points R_1 and R_2).

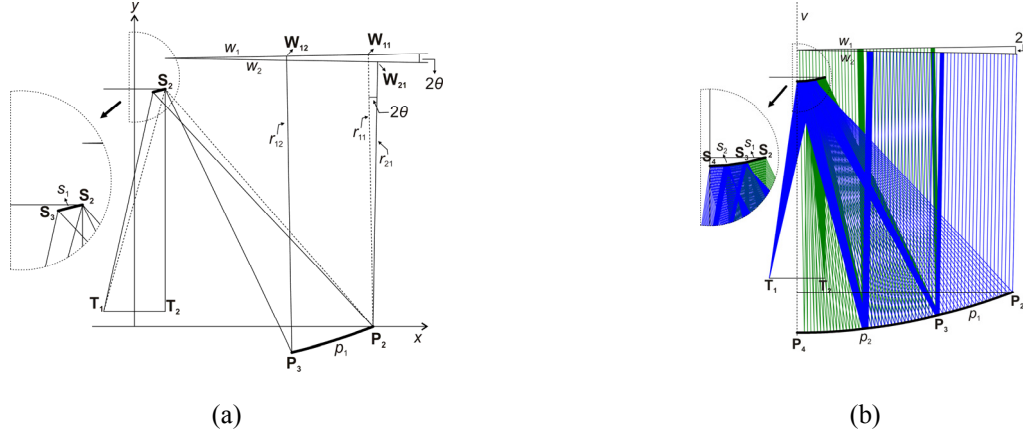

FIGURE 3. To The XX SMS optic design process. (a) the definition of the first portions p_1 and s_1 through the ray assignment. (b) the XX SMS chains.

Edge ray r_{11} , coming from point W_{11} (wave front w_1), is reflected at P_2 towards point S_2 and then reflected to edge T_1 . Edge ray r_{21} is launched from point W_{21} (wave front w_2) and it is reflected on portion p_1 at point P_2 towards point S_3 of surface s_1 . From S_3 the ray is reflected to the edge point T_1 . Edge ray r_{12} coming from the edge point T_2 is reflected at point S_2 towards point P_3 and finally redirected to point W_{12} (perpendicular to wave front w_1). The optical path lengths in this case are given by:

$$S_{21} = [W_{21}, P_2] + [P_2, S_3] + [S_3, T_1] \quad (7)$$

For ray r_{21} between the wave front w_2 and edge point T_1 .

$$S_{12} = [W_{12}, P_3] + [P_3, S_2] + [S_2, T_2] \quad (8)$$

For ray r_{12} between the wave front w_1 and edge point T_2 .

Now we can design the remaining portions using the SMS chains, as shown in Figure 3b. Emitting rays from w_2 and reflecting them on the primary (p_1 is the first portion to be used) we calculate the new portion of the secondary. Emitting rays from T_2 and reflecting them on the secondary (s_1 is the first portion to be used) to calculate the new portion of the primary. This process goes on and on until both the primary and secondary parts p_2 and s_2 touch the optical axis v . The other half of the primary and secondary is symmetric with respect to the vertical axis v .

RR SMS Optic Design

The RR SMS optic is used as a terceary optical stage, replacing the segment T_1T_2 (see Fig. 1), coupling the secondary to the receiver. In the past, there were some proposals of using CEC-type (Compound Elliptical Concentrator) as a terceary optic [1,2], linking T_1T_2 to R_1R_2 . Nevertheless, this solution might not be the ideal one for several reasons: i) the CEC has to be severally truncated and would not reach the maximum concentration; ii) it does not guarantee an uniform distribution of the irradiance at the receiver; iii) it touches the receiver inducing

thermal short circuits and iv) it perhaps still requires a cover on the top of it (for instance a glass cover) to close the cavity $T_1T_2-R_1R_2$ to avoid convection thermal losses.

In view of these reasons, a lens becomes as possible a solution since: i) It does not touch the receiver; ii) high concentration is possible using the SMS approach; iii) the lens can be used as the cover of the cavity at the same time. Thus, a RR SMS lens is proposed as the standard solution, following the same well-known design technique [15]. We start by calculating the normal vectors \mathbf{n}_1 and \mathbf{n}_2 at the edge T_1 (starting at T_2 is of course also possible), as shown in Fig. 4a. Ray r_1 coming from S_1 immersed in air ($n=1$), is refracted at T_1 immersed in a refractive index $n_L = 1.48$ towards point R_2 immersed in air, which defines \mathbf{n}_1 . Ray r_2 coming from R_1 is refracted at T_1 towards point S_2 , which defines \mathbf{n}_2 . Following a similar process to the XX SMS optic [16], one can calculate the SMS chains using the conservation of the optical path length, as shown in Fig. 4b.

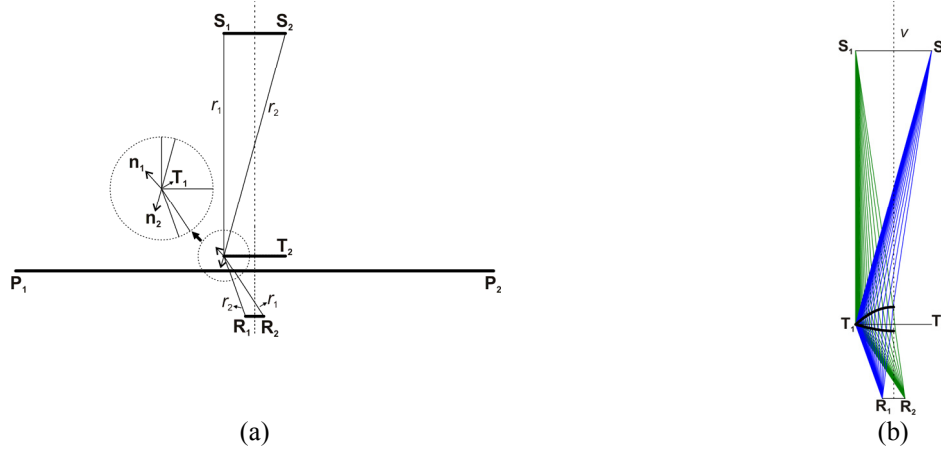

FIGURE 4. To The RR SMS optic design process. (a) Definition of the normals \mathbf{n}_1 and \mathbf{n}_2 (b) the RR SMS chains.

Final Configuration of the XXRR SMS Optic

Combining the SMS elements one can get the final configuration, a XXRR SMS concentrator, as shown in Fig. 5a. However, calculations have shown that this optics achieves a very small CAP (Concentration-Acceptance Product and it is given by $CAP = C \sin \theta$, which, in the limit ideal case is equal to 1) below 0.3. This is related to the limits of the refraction law of the lens. Plus, the lens as it is would not be practical due to its size and weight and, therefore, it is necessary to incorporate a Fresnel lens.

A possible way to increase the CAP is to introduce a trumpet concentrator. In fact, the flow lines connecting S_1S_2 and R_1R_2 are hyperbolas, as shown in Fig. 5b. According to the Winston-Welford design method [1,2] if a optic element (e.g., mirror, lens, etc.) is placed along the flow lines it will not change the radiative field but also conserve the etendue. The flow lines are also used to define the facets of the Fresnel lens.

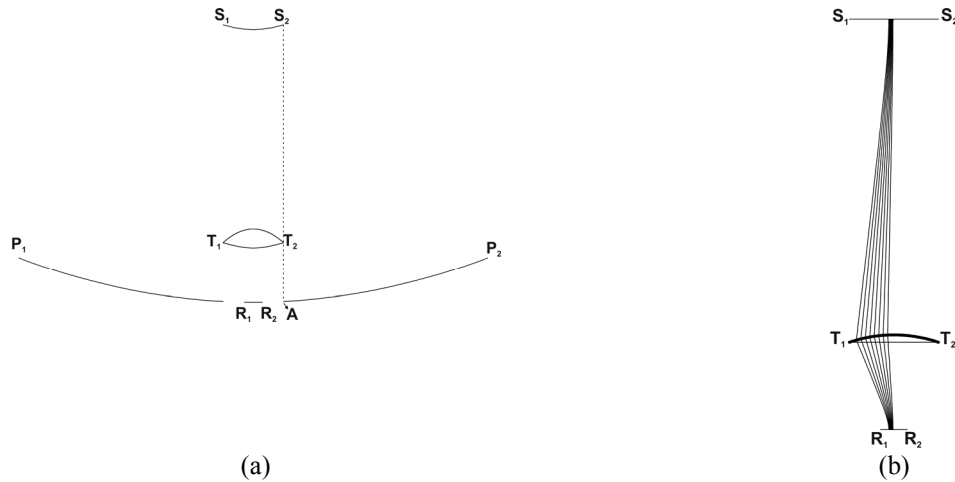

FIGURE 5. The XXRR SMS Optic. (a) The primary is truncated at point **A** to avoid shading losses. (b) The flow lines connecting **S₁S₂** and **R₁R₂** are hyperbolas.

Hence, starting at point **T₁** (**T₂** is of course also possible) the position and size of the final receiver is chosen using again the Hottel's string method. The final configuration is then composed by two primary mirrors, **P₁** and **P₂**, a secondary mirror, **S**, a Fresnel lens, **L**, two hyperbolic mirrors, **H₁** and **H₂**, and a final flat receiver, **R**, as shown in Fig. 6a. The complete optic is then obtained by rotation symmetry, as shown in fig. 6b.

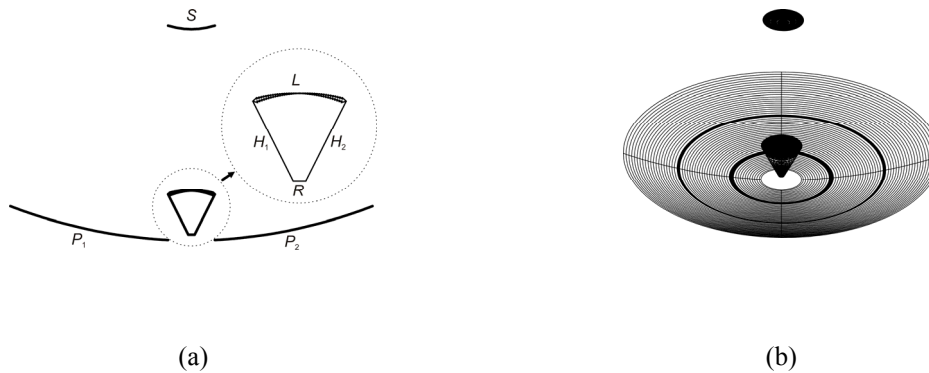

FIGURE 6. The SMS Parabolic Dish Cassegrain concentrator. (a) Overall view of the concentrator with a detail of the cavity receiver composed by a Fresnel lens and two hyperbolic arcs. (b) 3D view of the concentrator.

SYSTEM DATA AND EXPECTED PERFORMANCE

Table 1 presents the main geometric features of the concentrator as well as the expected performance. The calculations were done using a raytracing technique considering the following material properties: 92% of reflectivity of mirrors, 90% of transmissivity and refractive index of 1.48 for the Fresnel lens and 90% of absorptivity of the receiver.

TABLE 1. Geometric data and performance of the concentrator. Note: by mistake a value of 0.6 for the optical efficiency was presented in the abstract and it is now corrected.

Aperture width (m)	Receiver height (m)	Fresnel Lens width (m)	Receiver width (m)	η_{opt}	C_g	θ (deg)	CAP	Peak Power @ DNI 1000W/m ²
7	4.1	0.91	0.12	0.5	2339	0.58	0.49	24kW

Where η_{opt} is the optical efficiency at normal incidence, C_g is the geometric concentration factor, θ is the half-acceptance angle. The Power Peak was calculated without considering thermal losses and a useful mirror area of $\approx 40 \text{ m}^2$.

DISCUSSION OF RESULTS AND CONCLUSIONS

A Parabolic-dish type concentrator using a cassegrain approach was presented. This new configuration shows that it is possible to have a practical solution for such applications with the advantage of having the receiver much closer to the ground. The results presented in Table 1 show that this optic achieves a CAP much higher than the values obtained without using the trumpet concentrator (below 0.3). The acceptance-angle obtained is about 2 times the sun width ($\approx 0.27\text{deg}$). This is particularly important in these configurations due to the multiple optical stages which, in turn, require good optical tolerances to operate within the expected performance. This also shows the importance of the optimization of the systems dimensions through the conservation of the etendue (Hottel's string method).

The optical efficiency is, however, rather small and this is the typical drawback of such configurations. This happens due to the various optical stages of the concentrator through which the light passes and in particular due to the multiple reflections of the light inside the trumpet concentrator. Moreover, the trumpet may have similar problems as in the CEC solutions (thermal short circuits, non-uniformity light distribution, etc.).

In the future, other possibilities can be tested, in particular the use of Fresnel Köhler lens [17]. This has been successfully implemented in the CPV (Concentrated PhotoVoltaics) fields to achieve both high concentration and good light uniformity distribution over the receiver.

REFERENCES

1. Chaves, J., (2017), Introduction to Nonimaging Optics, Second Edition, CRC Press, Taylor and Francis Group.
2. Winston, R., Miñano, J.C., Benítez, P., (2005), Nonimaging Optics, Elsevier Academic Press, Amsterdam.
3. Rabl, A. (1985), Active Solar Collectors and their applications, Oxford University, Oxford.
4. Lovegrove, K. et al., "A new 500 m² paraboloidal dish solar concentrator" in *Solar Energy* **85** (2011) 620–626.
5. Coventry, J. and Andraka, C., "Dish systems for CSP", in *Solar Energy* **152** (2017) 140–170.
6. Mancini, T. et al., "Dish-Stirling Systems: An Overview of Development and Status" in *Journal of Solar Energy Engineering*, MAY 2003, Vol. **125** / 135, DOI: 10.1115/1.1562634
7. Segal, A., Epstein, M., "The optics of the solar tower reflector" in *Solar Energy* Vol. **69** (Suppl.), Nos. 1–6, pp. 229–241, 2000.
8. Grange, B. et al., "Preliminary optical, thermal and structural design of a 100 kWth CSPonD beam-down on-sun demonstration plant" in *Energy Procedia* **75** (2015) 2163-2168.
9. Vant-Hull, L., "Issues with beam-down concepts" in *Energy Procedia* **49** (2014), pp. 257 – 264.
10. United Sun Systems: <http://www.unitedsunsystems.com/>
11. Canavarró, D., et al., "New second-stage concentrators (XX SMS) for parabolic primaries; Comparison with conventional parabolic troughs concentrators" in *Solar Energy*, Volume **92**, June 2013, Pages 98–105.
12. Canavarró, D., et al., "Infinitesimal etendue and Simultaneous Multiple Surface (SMS) concentrators for fixed receiver troughs" in *Solar Energy*, Volume **97**, November 2013, Pages 493–504.
13. Canavarró, D., et al., "Simultaneous Multiple Surface method for Linear Fresnel concentrators with tubular receiver" in *Solar Energy*, Volume **110**, December 2014, Pages 105–116.
14. Canavarró, D., et al., "A novel Compound Elliptical-type Concentrator for parabolic primaries with tubular receiver" in *Solar Energy* Volume **134**, September 2016, Pages 383-391.
15. Miñano, J.C. et al., High efficiency nonimaging optics, United States Patent 6.639.733, 2003
16. Miñano, J.C. and González, J.C., "New method of design of nonimaging concentrators", *Appl. Opt.*, 31, 3051, 1992.
17. Benítez, O., et al., "High performance Fresnel-based photovoltaic concentrator" in *Optics Express* Vol. **18**, No. S1.