

MASTER  
IN PRODUCT AND INDUSTRIAL DESIGN

**Industrial Waste as Raw Material**  
*Application of almond nuts by-products in a bio-composite*

António Jorge Abreu Moreira Fernandes Teixeira

**M**  
2017





# Industrial Waste as Raw Material

Application of almond nuts in a bio-composite

Master in Product and Industrial Design

António Jorge Abreu Moreira Fernandes Teixeira

Supervised by Doctor José Luis Soares Esteves

Co-supervised by Doctor Bárbara Rangel Carvalho



## **O JÚRI**

### **PRESIDENTE**

Doutor Rui Mendonça,

PROFESSOR AUXILIAR DA FACULDADE DE BELAS ARTES DA UNIVERSIDADE DO PORTO

### **ORIENTADOR**

Doutor José Esteves

PROFESSOR AUXILIAR DA FACULDADE DE ENGENHARIA DA UNIVERSIDADE DO PORTO

### **ARGUENTE**

Doutor Nuno Loureiro

PROFESSOR ADJUNTO DO INSTITUTO SUPERIOR DE ENTRE DOURO E VOUGA

# **17**

27.10.2017

**MESTRE António Teixeira**  
**MDIP/38**



“The past can hurt. But the way I see it, you can either run from it or learn from it.”

By Rafiki, in the movie *The Lion King*

To all my beloved!





## Abstract

Even since its properties have been acknowledged and the immensity of its applications, oil has been the raw material that has had more impact on Earth and to such an extent everything we touch has some kind of relationship with oil. Either fortunately or unfortunately, plastic became an indispensable material with unique and innumerable properties and with many applications from simple packaging to complex engineering. As one of the main products resulting from oil, it accounted for 8,6% of its production in 2014. It has already surpassed the production of steel and the tendency is to increase even more with an estimated production of 540 million tonnes by 2020, when “only” 299 million tonnes were produced in 2013 and such an uncontrolled use of a non-degradable material, is threatening all life on Earth.

However, as a result of the abovementioned problems, in recent years there has been an effort to develop plastic derived from renewable resources and, thus provide manufacturers with a wider range of environment friendly alternatives. More and more efforts are being made in order to develop new ones. These plastics, besides having an ecological footprint with less negative impact on Earth, are also capable of biodegrade faster than the plastics derived from oil, which may take hundreds to hundreds of thousands of years to degrade.

Despite the fact that most of the materials are already known and natural resources well exploited, there is still room to innovate and create new materials, either through new technologies or new mixtures, among other possibilities. So, as far as new blends are concerned, renewable resources have arisen high interest in terms of their use as reinforcements in polymer matrices. Thus, given the existing organic waste and meager valuation and use, this can become a very interesting raw material to apply as a reinforcement that will reduce waste, increase its life cycle and make more ecological products.

Bearing this in mind, the development of a new bio-composite by mixing almond by-products particles with PLA, which is a biodegradable bio-based polymer derived from renewable resources seemed a good basis to match the aim of this dissertation.

Taking all this into consideration and after a quite substantial literature review, the experimental work began with the definition of the blending process and the implementation of an experimental work plan. The results of this study were positive since the resulting material presents a very interesting aesthetics and texture yet it is still necessary to proceed into a characterization of the material.

So, in sequence, it was necessary to identify at least one problem to explore a concept and develop a new product that would match some of the concerns of the modern world. In this case, the idea was to create a multifunctional stand and lapdesk for laptops, tablets and/or smartphones, where the created material would be applied. Finally, the production of the prototypes and user experience tests allowed to identify any existing problems as well as the pros of the products.

In short, after going through the several steps that made this dissertation viable, it was possible to conclude that almond by-products may have a potential use in the creation

of new bio-composites which have a consequent reduction on the use of oil-based polymers. It has also been concluded that it is necessary to continue to exploit other renewable resources, namely resulting from industrial waste, in order to create new bio-composites to have more and more alternatives to some of the most pollutant materials when creating new products.

## Keywords

Bio-composite; Almond by-products; Waste; Sustainability; Design

## Resumo

O petróleo é considerado o material que mais impacto teve na Terra, de tal forma que, quase tudo em que tocamos, é proveniente do mesmo. O plástico, material com propriedades únicas e inumeradas com muitas aplicações desde uma simples embalagem até engenharia complexa, é um dos principais produtos resultantes do petróleo, tendo representado 8,6% da produção do mesmo. A produção de plástico já ultrapassou a produção de aço e tende a aumentar, estimando-se que em 2020 se produzam cerca de 540 milhões de toneladas, quando em 2013 “apenas” se produziram 299 milhões de toneladas e, esta utilização descontrolada está a ameaçar toda a vida existente na Terra.

Contudo, derivado dos problemas mencionados acima, nos últimos anos surgiram e têm sido feitos cada vez mais esforços em torno do desenvolvimento de plásticos derivados de recursos naturais renováveis, para apresentar alternativas mais “amigas” do ambiente às indústrias. Este tipo de plásticos, para além de apresentarem uma pegada ecológica com menor impacto na Terra, também são capazes de se biodegradar mais rápido, ao invés do que se verifica com os plásticos derivados do petróleo, que podem levar centenas a centenas de milhares de anos a degradarem-se.

Apesar de se conhecerem quase todos os materiais e os recursos naturais estarem bastante explorados, ainda continua a ser possível inovar e criar novos materiais ora através das novas tecnologias, ora através de novas misturas, entre outros. No campo das novas misturas, os recursos naturais renováveis têm suscitado muito interesse na sua utilização como reforços em matrizes poliméricas. Assim, atendendo ao desperdício orgânico industrial existente e à sua pequena valorização/utilização, esta pode ser uma matéria-prima muito interessante para aplicar como reforço, reduzindo o desperdício, aumentando o seu ciclo-de-vida e tornando os produtos finais mais ecológicos.

Posto isto, esta dissertação tem como objetivo desenvolver e criar um novo biocompósito através da mistura de partículas de cascas de amêndoa resultantes da sua produção com PLA, um polímero biodegradável e derivado de recursos naturais.

Tendo isto em conta e após a revisão de literatura, o estudo experimental iniciou-se com a definição do processo de mistura e realização de um plano de trabalho experimental. Os resultados deste estudo foram positivos, pois o material obtido apresenta um aspeto e textura bastante interessantes, sendo que será necessário proceder à caracterização do material.

Após terminado o processo experimental e definido o material a utilizar iniciou-se o processo de desenvolvimento dos produtos. Assim, foi identificado um problema, idealizado um conceito e desenvolvida uma nova solução de suporte/base para computadores portáteis, tablets e smartphones. Por fim, a realização de protótipos e testes junto de um utilizador permitiram identificar problemas e mais-valias dos produtos.

Em suma, com a realização desta dissertação pôde-se concluir que o recurso aos subprodutos da amêndoa pode ser uma mais-valia na criação de compósitos

ecológicos e na consequente redução da utilização de plásticos derivados do petróleo. Também se concluí que é necessário continuar a exploração de outros recursos naturais, nomeadamente resultantes de desperdício industrial, de forma a criar novos biocompósitos e haver cada vez mais alternativas aos materiais mais poluentes para a criação de produtos.

## Palavras-chave

Biocompósito; Subprodutos da amêndoa; Desperdício; Sustentabilidade; Design

## Acknowledgments

I sincerely hope the completion of this stage of my life represents just one of the many that are about to happen yet, this stage would unquestionably not have been so enriching without the advice, support, help, friendship, fellowship and love of many people that I mention below:

I am very grateful to...

... my supervisor, Professor José Luís Esteves, for all his availability, support, help and fellowship;

... my co-supervisor, Doctor Bárbara Rangel Carvalho, for all her advice and support along this master degree;

... Emília Soares for all the availability, support and help in some of the experimental work;

... José Ramiro Soares for all the availability and help in grinding and milling the materials;

... Engineer Vitor Ferreira for all the availability and help in sieving the grinded and milled almond particles;

... Maria José Ramos for all the availability, advice, help and friendship.

... all the Professors and colleagues of this course, all the other employees from the Faculties of Fine Arts and Engineering of the University of Porto, *INEGI* and all my family and friends that somehow were available to support me in accomplishing this stage;

... the enterprises *Amendouro*, *XPIM – 3D Printing* and *Monteiros – Indústria Metalomecânica* for all the sympathy, services and comprehension along this work;

Last but not least, I want to give a special acknowledgement to...

... my mother for all the affection, love, support, help, friendship and freedom to follow my own way all over these years and to my father, who passed away in 2011, for the same reasons;

... my parents-in-law for all the affection, support and help since I started dating their daughter;

... my friend, girlfriend and wife, Daniela Monteiro, for all the affection, love, support, help, advice, day-by-day friendship, fellowship and patience.



# Contents

Abstract .....	VII
Resumo.....	IX
Acknowledgments.....	XI
Contents .....	XIII
List of figures .....	XVII
List of tables.....	XXIII
List of abbreviations and symbols.....	XXV
<b>1. Introduction .....</b>	<b>29</b>
1.1. Dissertation motivation.....	4
1.2. Contextualization .....	5
1.3. Problem definition and research questions .....	10
1.4. Objectives .....	11
1.5. Study object and methodology .....	12
1.6. Structure of dissertation.....	14
<b>2. State of Art .....</b>	<b>15</b>
2.1. Design and its importance on Earth’s sustainability .....	18
2.1.1. Design – what does it mean?.....	18
2.1.2. Design and science.....	19
2.1.3. Design and society .....	20
2.1.4. Design and sustainability .....	21
2.1.5. Design and emotions .....	22
2.2. Almond fruit.....	24
2.2.1. Almond’s culture cycle.....	27
2.2.2. Almond’s transformation process – visit to Amendouro.....	28
2.2.3. Almond’s industry waste possible applications .....	29
2.3. Polymeric materials .....	31
2.3.1. Bio-based polymeric materials .....	32
2.3.1.1. PLA .....	40
2.3.1.1.1. NatureWorks® Ingeo™ PLA.....	41
2.3.1.1.1.1. Ingeo™ Manufacturing Process.....	44
2.3.1.1.1.2. Ingeo™ End-of-life Options .....	46
2.3.1.2. Life Cycle Assessment .....	49

2.3.1.2.1. PLA – NatureWorks® Ingeo™ Life Cycle Assessment .....	50
2.3.2. Biodegradable Composite Materials with Polymeric Matrices .....	52
2.3.2.1. Additives for Polymers .....	52
2.4. Products made from food waste .....	55
<b>3. Case Study.....</b>	<b>63</b>
3.1. Bio-composite preparation.....	66
3.1.1. Blending experimental work.....	66
3.1.1.1. Materials, tools and equipment .....	69
3.1.1.2. Raw materials preparation.....	72
3.1.1.3. Blending experimental work .....	75
3.1.2. Experimental work with different granulometries .....	81
3.1.2.1. Plan of work for the experimental work with different granulometries .	82
3.1.2.2. Phase 1: Results and conclusion.....	83
3.1.2.3. Phase 2: Work plan, results and conclusion .....	84
3.1.3. Bio-composite production process.....	86
3.1.4. Additional experimental work.....	87
3.1.4.1. Almond by-products density determination .....	87
3.1.4.2. Microscopy visualisation and analysis of 3D printing wire .....	91
3.1.5. Experimental work conclusions .....	96
3.2. Application of the bio-composite: design proposal .....	97
3.2.1. Problem definition and ideation .....	97
3.2.2. Benchmarking.....	100
3.2.3. Product concept .....	109
3.2.4. Ergonomics applied to the product.....	110
3.2.5. Product development – Design proposal.....	113
3.2.5.1. Product development – Phase 1 .....	113
3.2.5.1.1. Sketches.....	113
3.2.5.1.2. 3D modelling.....	115
3.2.5.1.3. Prototype .....	118
3.2.5.2. Product development – Phase 2 .....	119
3.2.5.2.1. Sketches.....	120
3.2.5.2.2. 3D modelling.....	122
3.2.5.2.3. Prototype .....	127
3.2.6. Product validation .....	133



3.2.7. Renders .....	137
<b>4. Conclusion .....</b>	<b>141</b>
4.1. Generic conclusion.....	143
4.2. Study limitations.....	144
4.3. Future work .....	144
<b>5. References .....</b>	<b>147</b>
<b>6. Appendix .....</b>	<b>157</b>
6.1. Appendix I .....	159
6.2. Appendix II .....	160
6.3. Appendix III .....	162
6.4. Appendix IV .....	164
6.5. Appendix V.....	179



## List of figures

Figure 1: Illustrations based on the book <i>Cities for a Small Planet</i> of Richard Rogers expressing two different behaviours of a society regarding environment sustainability (Hebel, Wisniewska, and Heisel 2014). .....	9
Figure 2: Mind map created for this work. ....	13
Figure 3: Example of an almond kernel, with and without skin (Eu Como Sim). .....	25
Figure 4: Example of almond skin after almonds being peeled (Lemberona). ....	26
Figure 5: Almonds in shell (Nuts).....	26
Figure 6: Almonds in shell and hull, which is already mature and dried (Hilltop Ranch). .....	27
Figure 7: Example of an almond processing line by the steps abovementioned: 1. Containers/silos; 2.1. Rotary huller; 2.2. Shell cracker; 2.3. Smart sorter; 3.1. Steam scalding machine; 3.2. Blancher; 3.3. Continuous belt dryer; 4.1.1. Dicing machine; 4.1.2. Flour milling machine; 4.1.3. Slicer; 4.2. Compact separator; 5. Vacuum packaging machine (adapted from Jose Borrell S.A.). ....	29
Figure 8: Illustration of the products that can be made from a bushel of Yellow Dent #2 (Vink and Davies 2015). ....	44
Figure 9: Process of how plants make sugar (adapted from NatureWorks LLC 2016h). .....	45
Figure 10: Process of how NatureWorks® to obtain Ingeo™ pellets (adapted from NatureWorks LLC 2016h).....	46
Figure 11: Ingeo™ end-of-life options (NatureWorks LLC 2016h). ....	46
Figure 12: End-of-life road map (NatureWorks LLC 2016d). ....	47
Figure 13: Timetable for Ingeo™ composting process (NatureWorks LLC 2016b). ....	47
Figure 14: Comparison of the European data of the primary energy use of non-renewable resources for polymers production (Vink and Davies 2015). ....	50
Figure 15: Comparison of the European data of the global warming potential or greenhouse gas emissions for polymers production (Vink and Davies 2015). ....	50
Figure 16: Net NREU for the total Ingeo™ production system and the NREU per individual process (Vink and Davies 2015). ....	51
Figure 17: Net GWP for the total Ingeo™ production system and the GWP per individual process (Vink and Davies 2015). ....	51
Figure 18: Piñatex™ product range. From left to right: Piñatex™ Original Charcoal, Natural and Brown; Piñatex™ Oro Gold (Ananas Anam). ....	55
Figure 19: Example of some products using Piñatex™ (Ananas Anam). ....	55
Figure 20: MycoBoard™ application: Enjoy Handplanes Mushroom Board Fish (Ecovative Design). ....	56

Figure 21: MycoBoard™ application: Gunlocke® Savor guest seating (Gunlocke). ....	56
Figure 22: MycoFoam™ application: Mushroom® Packaging components that provide cushioning and bracing in large packages for Dell servers (Ecovative Design). ....	57
Figure 23: MycoFoam™ application: Stanhope Seta ships their products protected with Mushroom® Packaging (Ecovative Design). ....	57
Figure 24: MycoMake™ GIY Mushroom® material application: products made by the Designer Danielle Trofe (Morlin-Yron 2016). ....	57
Figure 25: Example of some products of the Husque™ enterprise (Husque). ....	58
Figure 26: Example of an application for the Nuxite (Rust Brothers). ....	58
Figure 27: Yock yoyo (Green & Associates). ....	59
Figure 28: Nook toy car (Green & Associates). ....	59
Figure 29: Hloopy photo frame (Green & Associates). ....	59
Figure 30: Decor flower pot (Future Power). ....	60
Figure 31: Tecnici flower pot (Future Power). ....	60
Figure 32: Good 4 Food tableware (Future Power). ....	60
Figure 33: Foodscapes food containers (Whomade). ....	61
Figure 34: Some of the Biotrem's products made from wheat bran and PLA (Biotrem 2017). ....	61
Figure 35: Process of removing part of the moisture from the almond by-products by placing them in a furnace, for 12h at 80°C, in the Heat Treatment Laboratory. ....	72
Figure 36: Process of grinding the almond by-products, that have been partially dried, in a grinder in the Laboratory of the DEMM. ....	73
Figure 37: Process of milling the grinded almond by-products in a vibratory disc miller in the Laboratory of the DEMM. ....	73
Figure 38: Process of sieving the grinded and milled almond by-products in a vibratory sieve shaker in INEGI. ....	73
Figure 39: Process of separating the sieved particles into plastic zip bags by particle-size distribution in INEGI. ....	74
Figure 40: Second drying process of the almond by-products particles just before being blended with the PLA in the chamber furnace, for 6h at 65°C in the Heat Treatment Laboratory. ....	74
Figure 41: Process of grinding the PLA in a grinder in the Laboratory of the DEMM. .	74
Figure 42: Measuring the weight of the PLA and almond by-product particles before being blended. ....	75
Figure 43: Melting the PLA pellets in a frying pan. ....	75
Figure 44: Blending the melted PLA with the almond by-products particles. ....	75

Figure 45: Creating a plate by hand pressure using two baking trays.....	76
Figure 46: Removing the plate with the new material.....	76
Figure 47: Creating a coffee cup by hand pressure using a silicone mould. ....	77
Figure 48: Removing the coffee cup with 5% of reinforcement from the silicone mould. .....	77
Figure 49: Defects in the base of the coffee cups.....	78
Figure 50: Plates before and after being grinded. ....	78
Figure 51: Placement of material in the cylinder to eliminate any residues of other polymers.....	79
Figure 52: Preparing the mould for an injection. ....	79
Figure 53: Opening the mould after the injection of the material.....	79
Figure 54: Defects in two injected pieces. ....	80
Figure 55: Mixing grinded PLA with the almond by-products particles.....	81
Figure 56: Process of cleaning the cylinder of the injection machine.....	81
Figure 57: Step g – Process of placing the melted material in the aluminium cupcake mould, which was previously sprayed with a release agent spray, and hand pressure with the help of a stick to avoid burning in the hands.....	82
Figure 58: Step h – Process of removing the piece from the aluminium cupcake mould. .....	82
Figure 59: Material blending in a twin-screw extruder (Essabir et al. 2016).....	87
Figure 60: Process for determining the density of the almond by-products using a pycnometer for solid materials.....	89
Figure 61: 3D printing wires – PLA + wood fibres on the left, and PLA + coffee particles on the right. ....	91
Figure 62: Process of preparation of the samples till the microscope observation. ....	92
Figure 63: Observation of the samples – on the left, wires in the vertical position and, on the right, wires in the horizontal position; WCP on the top and WWF on the bottom. .....	94
Figure 64: Second sample – WWF on the left and WCP on the right. ....	94
Figure 65: Example of one image of each wire from the second sample – WWF on the left and WCP on the right.....	94
Figure 66: Example of how it was calculated the percentage of reinforcement in each wire – WWF on the left and WCP on the right.....	95
Figure 67: Shipment of laptops, desktop PCs and tablets worldwide from 2010 to 2015 and forecast to 2016, 2019 and 2020 (Statista). ....	98
Figure 68: Movements associated with neck flexion and rotation, and wrist extension and ulnar deviation (adapted from Panero and Zelnik 2013).....	98

Figure 69: Differences of the posture while working with and without a riser with external devices, as shown by the example on the right (Bakker Elkhuizen). .....	99
Figure 70: The most common posture adopted by laptop users while working on the lap - image on the left by Bakker Elkhuizen and image on the right by Vodafone (adapted from Bakker Elkhuizen; Schofield 2013).....	99
Figure 71: Two different entities suggestions of using an object to place under the laptop while working on the lap – image on the left by Bakker Elkhuizen and image on the right by Vodafone (adapted from Bakker Elkhuizen; Schofield 2013).....	100
Figure 72: Mind map created for the product concept. ....	110
Figure 73: Images that show the movement of the head in the vertical plain (A), the range of movements of the head and eyes in the vertical plane (B), the field of vision in the vertical plane (C) and field of vision with the head at zero degrees (D) (adapted from Panero and Zelnik 2013). ....	111
Figure 74: Field of vision with the head and the standard line of vision at 22.5 degrees (adapted from Panero and Zelnik 2013).....	112
Figure 75: Differences in the posture and wrist while working with a laptop on the lap, with and without a lapdesk (adapted from Bakker Elkhuizen). ....	112
Figure 76: Development process of the multifunctional stand through sketches.....	114
Figure 77: Different parts of the multifunctional stand. ....	115
Figure 78: Isometric (top and bottom), top and right views of the 3D model of the three parts of the multifunctional stand. ....	116
Figure 79: Final product, with the three different parts assembled, representing all the possible configurations.....	117
Figure 80: Prototype, using a FDM 3D printer, of the three parts and respective assembling with configurations P1, P3 and P4.....	118
Figure 81: The multifunctional stand cannot prevent smartphones or tablets from toppling. ....	119
Figure 82: The different heights from configuration P2 and P3 and a section view from the right side of the assembling to demonstrate where part C should be placed by the user. ....	119
Figure 83: Development process and modifications on the multifunctional stand and the lapdesk in sketches. ....	122
Figure 84: Different parts of the new multifunctional stand and of the lapdesk.....	122
Figure 85: Isometric (top and bottom), top and right views of the 3D model of different parts of the multifunctional stand and lapdesk. ....	124
Figure 86: Final products, with all the parts assembled, representing all the possible configurations of the multifunctional stand and of the lapdesk. ....	126

Figure 87: Second prototype, using a FDM 3D printer, of the three parts of the multifunctional stand and respective assembling with configurations P1', P2', P3' and P4'.....	127
Figure 88: Testing of the second multifunctional stand prototype considering the problems identified in the first prototype. ....	128
Figure 89: Applying a small force in the top of the smartphone, it will easily topple. ....	128
Figure 90: Representation of how part C gets fixed and trying to pull part C from the fixed position. ....	128
Figure 91: The multifunctional stand before and after being extended in the back of part B.....	129
Figure 92: Above, 3D model and prototype of the extending part and below already glued to the multifunctional stand.....	129
Figure 93: Testing of the multifunctional stand with the extending part. ....	130
Figure 94: Suggestion of a modification to easily pull part C when fixed in part A....	130
Figure 95: Different parts obtained by using a laser cutting machine of the prototype of the lapdesk and respective assembly.....	131
Figure 96: Suggestion of a modification to increase the strength of the slats of part D. ....	132
Figure 97: Detail and images illustrating how the multifunctional stand fits and gets stuck in the slats. ....	132
Figure 98: Placing the prototype of the lapdesk in a 15.6in laptop backpack to check if it fits.....	133
Figure 99: The user testing to type on the laptop over the lapdesk with the possible configurations.....	134
Figure 100: The user testing the sliding surface both for the mouse and to write on a book. ....	135
Figure 101: Testing the multifunctional stand to rise the back part of the laptop while working on a table. ....	135
Figure 102: User trying the multifunctional stand with a smartphone, table and laptop on a table and on a sofa. ....	136
Figure 103: Texture applied in the designed products.....	137
Figure 104: Renders of the different configurations of the multifunctional stand. ....	138
Figure 105: Renders of the different configurations of the lapdesk, as well as different colours for parts F and G.....	139
Figure 106: Multifunctional stand and lapdesk in different contexts of use.....	140





## List of tables

Table 1: List of edible nuts (Wickens 1995).....	24
Table 2: Classification of bio-polymers based on their origin (Niaounakis 2013a).....	35
Table 3: Comparison of overall properties of some bio-polymers (adapted from NaturePlast 2016d). .....	37
Table 4: Properties of some bio-polymers (Sastri 2014). .....	38
Table 5: Sustainability improvements of bio-based plastics relative to oil-based plastic (Álvarez-Chávez et al. 2012). .....	39
Table 6: Certifications for Ingeo™ (Natureworks LLC 2016e). .....	42
Table 7: Comparing of energy values of some materials (NatureWorks LLC 2016i). ...	48
Table 8: Results of the elemental analysis and decomposition products when burning Ingeo™ (NatureWorks LLC 2016i). .....	48
Table 9: Blending experimental work plan to assess the best way to blend the materials. ....	68
Table 10: Materials used during blending experimental work. ....	69
Table 11: Some tools used during the blending experimental work.....	70
Table 12: Equipment used during blending experimental work. ....	72
Table 13: Final results of blending experimentation 1. ....	76
Table 14: Final results of blending experimentation 2. ....	78
Table 15: Final results of blending experimentation 3. ....	80
Table 16: Plan of work for phase 1 experimental work. ....	83
Table 17: Results of phase 1 experimental work.....	84
Table 18: Plan of work for phase 2 experimental work. ....	85
Table 19: Results of phase 2 experimental work.....	85
Table 20: Results of the measurements of the temperature using a thermometer and of the mass using a pycnometer to determine the density of the almond by-products...	90
Table 21: Determination of the density for each sample of almond by-products. ....	91
Table 22: Results of the analysis of the pictures of each wire.....	95
Table 23: Benchmarking study of laptop stands and/or lapdesks (Actto; Woody Life; Bakker Elkhuisen; Stood; Logitech; RLDH; Aidata; LapGear®; Royal Craft Wood; iSkelter).....	107
Table 24: Matrix of needs to compare the most important features of the products of the benchmarking. ....	108
Table 25: Matrix of needs for the design proposal of a lapdesk and multifunctional stand. ....	133



## List of abbreviations and symbols

3D – Three Dimensions  
ASTM – American Society for Testing and Materials  
CAD – Computer-Aided Design  
CEN – European Committee for Standardization  
CEO – Chief Executive Officer  
DEMM – Department of Metallurgical and Materials Engineering  
DIN – German Institute for Standardization  
Dr. – Doctor  
DS – Design Studio  
EN – European Standards  
EVA – Ethylene-vinyl Acetate  
FAOSTAT – Food and Agriculture Organization of the United Nations  
FEUP – Faculty of Engineering of University of Porto  
FDM – Fused Deposition Modeling  
FNR – Agency for Renewable Resources  
GDP – Gross Domestic Product  
GHG – Greenhouse Gases  
GM – Genetically Modified  
GMO – Genetically Modified Organisms  
GWP – Global Warming Potential  
HDPE – High Density Polyethylene  
HTL – Heat Treatment Laboratory  
IATP – Institute of Agriculture and Trade Policy  
IDSA – Industrial Designers Society of America  
INEGI – Institute of Science and Innovation in Mechanical and Industrial Engineering  
ISCC – International Sustainability & Carbon Certification  
LCA – Life Cycle Assessment  
LCI – Life Cycle Inventory  
ML – Materialography Laboratory  
NDLTD – Networked Digital Library of Theses and Dissertations  
NGO – Non-governmental Organization  
NREU – Non-renewable Energy Use  
PBAT – Polybutyrate Adipate Terephthalate  
PC – Personal computer  
PC – Polycarbonate  
PDLA – Poly(D-lactide)  
PDLLA – Poly(DL-lactide)  
PET – Polyethylene Terephthalate  
PLA – Polylactic acid  
PLLA – Poly(L-lactide)  
PP – Polypropylene  
PS – Polystyrene  
SiC – silicon carbide

US – United States  
USA – United States of America  
USDA – United States Department of Agriculture  
UV – Ultraviolet  
VAT – Value-added tax  
WCP – Wire Containing Coffe Particles  
WLC – Working Landscapes Certificate  
WTE – Waste-to-energy  
WWF – Wire Containing Wood Fibres

≈ – Approximately equal

< – Less-than

% – Percentage

” – Inches

BTU/lb – British thermal unit per pound

bu/acre – Bushels per acre

cm<sup>3</sup> – Cubic centimetre

CO<sub>2</sub> – Carbon Dioxide

CO<sub>2</sub> eq./kg – Carbone dioxide equivalents per kilogram

€ – Euro

g/cm<sup>3</sup> – Grass per cubic centimetre

GPa – Gigapascal

h – Hour

H<sub>2</sub>O – Water

in – Inches

kg – Kilogram

kJ/kg – Kilojoules per kilogram

kW – KiloWatt

min – Minute

MJ/kg – MegaJoule per kilogram

mm – Millimetre

MPa – Megapascal

ρ – Density

°C – Degree Celsius

® – Registered trademark

\$ – US Dollar

s – Second

TM – Trademark

µm – Micrometre

## Notes to the reader:

- All the text was written and translated into English by the author.
- All the figures without any reference are authorship of the author.
- Throughout the dissertation, whenever the word “product” is used, it refers to any type of “product”, either physical products, services, software applications, websites or interactive products included yet not limited to these.
- In turn, whenever the word “plastic” is used, it refers to any type of polymer.



# 1. Introduction





This chapter, as the title indicates, introduces this dissertation theme, as well as, other topics related to it. Thus, firstly, it is presented the motivation of doing this research and how it occurred.

Secondly, comes a chapter making the contextualization with the subject regarding the theme. Considering this, it was made a literature review and written about the following subjects: oil, oil-based polymers and its problems to the environment, environment awareness, bio-based polymers, agro-industry, organic waste, green ideology and zero-waste philosophy.

This chapter is followed by three chapters that are regarding the problem definition of what the dissertation is going to be around and its research questions, the objectives of this research and the definition of the study object, as well as, a short explanation of how this work is going to be made.

Finally, the last chapter presents a resume of each main chapter of this dissertation.

## 1.1. Dissertation motivation

The motivation for the realization of this dissertation emerged while I was helping both my brother and sister-in-law producing granola, the main product of their enterprise. Granola is defined as a type of breakfast cereal made of grains, nuts, etc. that have been toasted (Oxford Learner's Dictionaries 2016). Their product, in addition to other ingredients, is constituted by almond nuts, which is bought without shell. Thus, in a moment of reflection, I wondered what happens to almond shells and why they are not being used as raw material in the production of new products. This thought could be applied, not only to almond nuts, but to all kinds of nuts.

So, after a quick research, it was possible to find that there are already many papers reporting studies using nuts waste, such as hulls, shells, and skins, mainly focusing in the reinforcement of thermoplastics. Besides these, there was no innovative use for this type of waste, except for the use for incineration to produce heat or electricity, animal feedstock or, simply being dumped.

It is well known that nowadays the human being must have environmental responsibilities in order to have and provide a better future on Earth. Bearing this in mind, and considering the available research about the subject, the decision was to explore the use of almond's industry waste as an additive to polymer matrices to apply in new products.

## 1.2. Contextualization

*“Over the past decade, the demand for solutions to move to a society that has its production based on environmentally responsible materials has rapidly increased” (Karana 2012). “Concepts such as sustainable development, industrial ecology and green chemistry led to the development of new generations of composite materials that are constantly evolving toward more efficient and less expensive products in response to environmental constraints and regulatory requirements” (Essabir et al. 2016).*

The need to find new environment friendly solutions, to adopt new lifestyles and to create new regulations and directives from our governments are just some of the things that the human being can do in order to expect a better future on Earth. Regarding this, on this document, alternatives for the actual problem of oil-based plastics by using bio-based plastic reinforced with almond nuts waste will be presented but, first, contextualization with the main subjects – plastics and agro-industry – is obviously required.

There is no material on Earth that has ever had the impact of oil (Elvin 2015). Humans have worked over oil for many years to find utilities for it and, nowadays, almost everything we can touch somehow depends on oil. However, this resource, which gave us the power to change the Earth, is now threatening every form of life on it (Elvin 2015), and our dependence on it leads to concerns in terms of economic and environmental sustainability. Considering George Elvin words, we should use the good things that oil provided in order to design a post-petroleum world without its negative side effects (Elvin 2015).

One of the markets for oil is the production of plastic, consuming about 2,5 billion barrels of oil per year (Elvin 2015). In 2014, the production of oil was of approximately 29 billion barrels, so plastic production represented approximately 8,6% of it (Central Intelligence Agency 2016). Plastic materials have unique and innumerable properties which have a lot of applications from simple packaging to complex engineering. Plastic production increased from 7 million tonnes in 1960 to 160 million tonnes in 2000, to 299 million tonnes in 2013 and it is expected to reach 540 million tonnes by 2020 (Elvin 2015; PlasticsEurope 2014). Moreover, it has already surpassed steel production. Plastic is a very useful material, since it provides great properties for manufacturers at a low cost, however, it is also one of the biggest pollutants on Earth. Besides being crafted from carbon that has been locked up in the Earth for millions of years, its high durability and resistance to degradation has created environmental problems as far as end-of-life disposal is concerned. Recycling is obviously an option to the end-of-life of plastic material but only about one tenth will be recycled (Elvin 2015), which means that nine in ten millions of tonnes of plastic will end up polluting landfills alongside the other five billion tonnes of other plastic waste (Elvin 2015). It is important to refer that the degradation of plastic may take hundreds to hundreds of thousands of years. Incineration is also an option but this would result in a net increase in the release of greenhouse gases (GHG) into the atmosphere (Hottle, Bilec, and Landis 2013).

“The true question, says Kmetz, is when the global demand for oil will exceed the ability to produce it? Many believe that this will happen sooner rather than later and when it

occurs, our lives will get much more interesting. The impact on many industries, including plastics, is likely to be profound” (Elvin 2015).

In recent years, driven by increasing environmental awareness, the interest and research over products that are both made from renewable raw materials and able to decompose in a friendly way in a natural environment have been rapidly increasing. New regulations and initiatives, green movements and social awareness are among the factors that are helping to reduce plastic waste generated every year. Moreover, consumers have expressed the desire for products that are environment friendly but this preference can be hindered by the higher cost of these products when compared to oil-based ones (Niaounakis 2015b). These products can be made of bio-based plastic, the “new” generation of plastic.

Considering the book *Post-petroleum design*, bio-based plastics have been used for food, furniture and clothing for thousands of years and the first artificial thermoplastic polymer “celluloid” was invented in the 1860s (Elvin 2015). Bio-based plastic is made from renewable resources such as vegetable oil, starch, cellulosic feedstocks, grass, residual biomass, etc. (Karana 2012). Such plastics have important advantages over oil-based plastics since they can biodegrade much faster, may contain fewer toxins and have a smaller carbon footprint (Elvin 2015). For example, the production of the bio-based plastic polylactic acid (PLA) uses 30% to 50% less oil and generates 50% to 70% less carbon dioxide than oil-based plastic (Elvin 2015). In fact, these differences are related to the carbon found on renewable sources being derived from atmospheric CO<sub>2</sub>, which is used as biomass during the growth of plants creating a carbon closed loop, while oil-based plastic carbon returns to the atmosphere as CO<sub>2</sub> (Philp, Ritchie, and Guy 2013). Currently, the main market for bio-based plastics is the packaging industry but they are already used in industries that require high performance plastics, as for example, the automotive industry. One of the obstacles of using these polymers is their cost, making it more expensive for manufacturers and consumers when compared to oil-based plastic but there are already improvements that allow producing them in a cheaper way making it possible for some bio-based plastics to compete with the oil-based ones in terms of cost.

The fact that oil was considered as an infinite resource some years ago, besides being easier and much cheaper to transform into plastic, and thus more attractive for manufacturers, made it responsible for almost everyone to ignore the existence of bio-based plastic until very recently. This almost brought bio-based plastic to extinction, corresponding, in 2015, to only less than 0,3% of the global plastic market yet with an increasing production rate of nearly 40% per year, it is now one of the world’s fastest-growing markets (Elvin 2015). Furthermore, it is stated that “up to 90% of the current global consumption of polymers can technically be converted from oil to renewable resources” (Elvin 2015). However, scientists at the University of Massachusetts-Lowell concluded, in a research, that “none of the bio-based plastics currently in commercial use or under development are fully sustainable” since the bio-based plastics they have reviewed were using genetically modified organisms for feedstock manufacture and/or toxic chemicals during production or generate these as by-products, and/or co-polymers from non-renewable resources (Elvin 2015). But this is not a fact for all manufacturers of bio-based polymers as you can see in chapter 2.3.

According to Ashby et al., almost every material we use nowadays was developed during the last one hundred years (Ramalhete, Senos, and Aguiar 2010). Even though, it is still possible to create new materials due to the technology development, newly found materials, new blends, etc. and, regarding this, one way to innovate in materials is using natural fillers as reinforcement in thermoplastics which have increasing interest and applications. Lignocellulosic fillers, as for example nuts hulls and shells and wood, have increasing interest in being used in the reinforcement of thermoplastics due to their low density, improvement of mechanical properties, high availability, non-toxicity and recycling possibility (Ayrimis, Kaymakci, and Ozdemir 2013). Moreover, a great number of these fillers can be obtained from industries' waste, such as the agro-industry or timber industry.

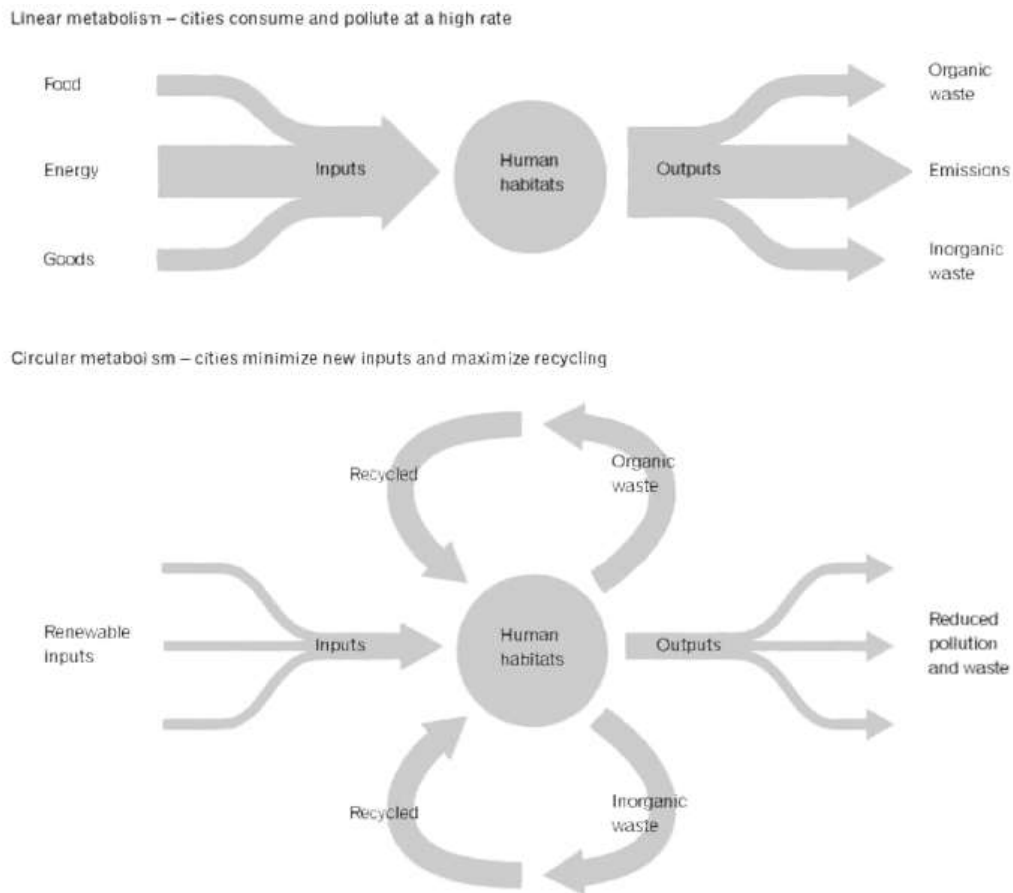
Considering this dissertation subject, it was important to make a literature review on agro-industry. Thus, the agro-industry is one of the most important industries in the world and corresponds to 6,5% of the world gross domestic product (GDP) – GDP composition by sector of origin is divided in three: agriculture (6,5%), industry (31,1%) and services (62,4%) – including farming, fishing and forestry (Central Intelligence Agency 2016). Unfortunately, this industry cannot take advantage of all feedstock – the Food and Agriculture Organisation of the United Nations states that roughly one third of edible food produced for human consumption is wasted (EUROPEN) –, producing a lot of organic waste which even though being among the fastest degrading materials, also contributes negatively to the emissions of methane if dumped in landfills (Kolstad et al. 2012).

Organic waste is very important since biomass can be used as an energy source, mainly by combustion processes. Despite the emissions released in the combustion process, this energy is cleaner than the energy generated from oil, which brings many implications to the environment by producing emissions to the atmosphere of many contaminant compounds that contribute to the greenhouse effect and to the acidification of ground and water (González et al. 2005). But if this organic waste has possible applications and uses, should it be named as “waste”? The meaning of waste can be complex because what is regarded as waste for one person may not have the same significance to another. However, waste can be simply defined as unwanted materials. Thus, while organic waste is unwanted material for the agro-industry, it is a source for the energy production industry.

It is known that the social, economic and sustainable development of the humankind depends on a better use of the available resources to preserve life on Earth. As abovementioned, organic waste is mainly used for combustion to produce energy, but it can also be used as fillers for thermoplastics. Maybe there are a lot of available resources which can have different applications but first there is the need to identify the available waste and how to value it. Basically, researchers, manufacturers, engineers, designers, architects, etc. should consider a cradle-to-cradle life cycle framework – instead of the most common cradle-to-grave – where all materials have a continuous circular process like what happens in Nature's life cycles. Products' life cycle management must take into consideration these stages: raw material extraction, production, transportation, packaging, use and final destination (adapted from Peneda and Frazão 1995). This means that during any product development, each stage of its

life cycle should be considered in order to become part of a continuous recovery and reutilization process (Hebel, Wisniewska, and Heisel 2014).

While going through literature review it was found a definition for Zero-Waste philosophy proposed by *Zero Waste International Alliance* in 2004, which has a very important goal to achieve: "Zero-Waste is a goal that is ethical, economical, efficient and visionary, to guide people in changing their lifestyles and practices to emulate sustainable natural cycles, where all discarded materials are designed to become resources for others to use. Zero-Waste means designing and managing products and processes to systematically avoid and eliminate the volume and toxicity of waste and materials, conserve and recover all resources, and not burn or bury them. Implementing Zero-Waste will eliminate all discharges to land, water or air that are a threat to planetary, human, animal or plant health" (Hebel, Wisniewska, and Heisel 2014). It is important to mention that not only manufacturers must have environmental responsibility but also the consumers should have an ethically active role to reuse end-of-life products as a resource, avoiding waste production based on the unsustainable "make-take-throw" lifestyle (Hebel, Wisniewska, and Heisel 2014). The European Union has already introduced a system called "extended producer responsibility", which can be defined as "an environmental policy approach in which a producer's responsibility for a product is extended to the post-consumer stage of a product's life cycle" (European Commission 2015). In other words, besides being responsible for the decisions taken during product development, manufacturers should also have the responsibility to know and transmit how to deal with the products when they reach the end-of-life cycle. However, from the moment when a product leaves the factory and the moment when that product enters a waste management system, the consumer must have the responsibility to place the product in the beginning of the waste management cycle. Two illustrations (Figure 1) based on the book *Cities for a Small Planet* written by Richard Rogers, express the difference of following a zero-waste philosophy or not, circular metabolism and linear metabolism, respectively.



**Figure 1:** Illustrations based on the book *Cities for a Small Planet* of Richard Rogers expressing two different behaviours of a society regarding environment sustainability (Hebel, Wisniewska, and Heisel 2014).

“In the last century or so, chemists and chemical engineers have (...) developed thousands of plastics for use in tens of thousands of applications, if not more. That means that we’ll need to find replacements for these oil-based plastics for every one of those uses, probably from previously unconsidered renewable sources. It’ll be a different world” affirmed Dr. Debbie Chachra, Associate Professor of Materials Science at Olin College of Engineering (Elvin 2015).

According to Ramalhete, Senos, and Aguiar (2010), throughout history, the knowledge of new materials and technologies was the motivation for humans to begin the creation of a new project. Even more, the history of design shows that there is a relationship between the new art and aesthetic movements, and the use of new materials and technologies so the discovery of new materials may imply the production of new objects.

In this context, this research has as goal to find a solution that is environment friendly for one or more applications by using a bio-based plastic and almond nuts, shells and skins, which are considered an organic waste, to create a bio-composite.

### 1.3. Problem definition and research questions

Plastic and agro-industry represent the two main subjects on which the contextualization of this research is focused. For each of them there is reference to one main problem: oil-based plastics pollution and organic waste, respectively. Finally, actual solutions for both situations will be presented: bio-based plastics and reinforcement for plastics, respectively; yet, if the abovementioned problems already have some kind of solution, what else it is possible to do? Before coming to a conclusion, let us consider the following paragraphs.

The authors of the book *Building from Waste* wrote that Marc Angelil and Cary Siress, in their paper *Re: Going Around in Circles, Regimes of Waste* stated that “waste and its meticulous handling are valued as gifts, offered by society to itself. Perhaps then we would come full circle in being sustained by the constant transformation of matter and energy at hand, without beginning and without end.” They also add, based on words from Georges Bataille and other authors, that “waste is a gift that needs to be freed from its “pejorative stigma”.” “Their call to understand waste as part of societies’ wealth follows, in fact, also an economic principle: waste production is an investment that needs to be returned” (Hebel, Wisniewska, and Heisel 2014).

Waste is the dissipation of natural resources, considering alone energy, water and other materials that were used to produce from virgin or recycled raw materials the discarded products (Hebel, Wisniewska, and Heisel 2014). Therefore, Hebel, Wisniewska, and Heisel (2014) mention that our society should be able to generate profit of its constant reformulation, which is in accordance with zero-waste philosophy. Waste still has an unrecognised value by society but as soon as they are able to recognize it, waste will never more be waste; it will be a valuable resource.

The opening sentence of the first chapter of Stevens’ book *Green Plastics, an Introduction to the New Science of Biodegradable Plastics* reads: “No material on earth has been so highly valued for its usefulness, yet so malignant, as plastic” (Philp et al. 2013).

As aforementioned the durability and capability to resist to natural degradation of plastics are threatening the ecosystem natural cycle. The uncontrolled disposal in landfills, the accumulation of large quantities of plastic waste and the emissions of GHG to the atmosphere are the biggest problems of oil-based and non-biodegradable plastics. Bio-based plastics, being biodegradable or not, are at this moment at the top of the best solutions to reduce the problems caused by oil-based plastics.

Considering this, there are a lot of solutions to be created, improved, substituted, etc. The solutions that were presented before are just some among those that can be used by our society nowadays but who knows which ones have the best response to these environmental issues? So, the main research question for this dissertation is to ask what can be done, from an engineer and designer’s point of view, to contribute to the ideation of one or more solutions to help solving such worldwide issue.



## 1.4. Objectives

*“Environmental changes in our fragile planet are a consequence of what we do and the tools we use. Now that the changes we cause are so big and threatening, it is imperative that designers (...) make their contribution to help find solutions. (...) Unless we learn to preserve and conserve the Earth's resources, and to change our basic patterns of consumption, manufacturing and recycling, we can't have a future” (adapted from Papanek 1995).*

After all, regarding the dissertation motivation, contextualization and problem definition, the main objective of this research is to present a new product design to apply, as material, a bio-composite, which is going to be studied in this dissertation. Bearing this in mind, it is intended to use a bio-based biodegradable polymer as matrix and almond nuts waste as reinforcement following the Zero-Waste philosophy, as mentioned in chapter 1.2. Taking this into consideration, besides using a great alternative for oil-based plastics, it is also intended to create value for almonds nuts waste and others that could be somehow connected with this dissertation, such as other nuts waste, for example. Moreover, it is important to appeal to human beings' ethical responsibility and consumers' emotional sense in order to make them understand that they can have the same products with environment friendly footprints.

## 1.5. Study object and methodology

To accomplish this dissertation and thus by achieve the outlined objectives, a small literature review in order to select the most appropriate materials for the research was obviously undertaken. Bearing the collected data in mind and, since the intention was to use a composite based on a biodegradable bio-based thermoplastic matrix and almond nuts waste as a filler for reinforcement, the decision was to use as thermoplastic the *Ingeo<sup>TM</sup>* PLA of *NatureWorks<sup>®</sup>*. This choice is related to the fact that *NatureWorks<sup>®</sup>* has great environmental criteria for their products (chapter 2.3.1.1.1) and, besides the reason to use almonds nuts waste expressed in the motivation, there are some papers with good indications about the use of almond nuts as a filler in thermoplastics (chapter 2.2.3). Moreover, *Amendouro*, as presented ahead in chapter 2.2.2, provided some hulls, shells and skins, resulting of the almond transformation process, to be used on this research.

Using a biodegradable thermoplastic matrix reinforced with almond by-products from almond industry waste is an attractive alternative to transform agricultural waste into a useful industrial resource, with a positive benefit for the environment, energy and economy (Valdés García et al. 2014), since this bio-composite will extend and create value for the almond industry waste, as well as, avoid the use of non-biodegradable polymers, which may take hundreds of years to decompose.

At this phase of the research, a mind map (Figure 2) has been done to organize and have a better perception of the work that should be done in order to achieve the objectives outlined. The start point of the mind map is the biodegradable bio-based material using PLA and almond nuts waste, and from this arise three main branches for this work: literature review, bio-composite materials and product & material application.

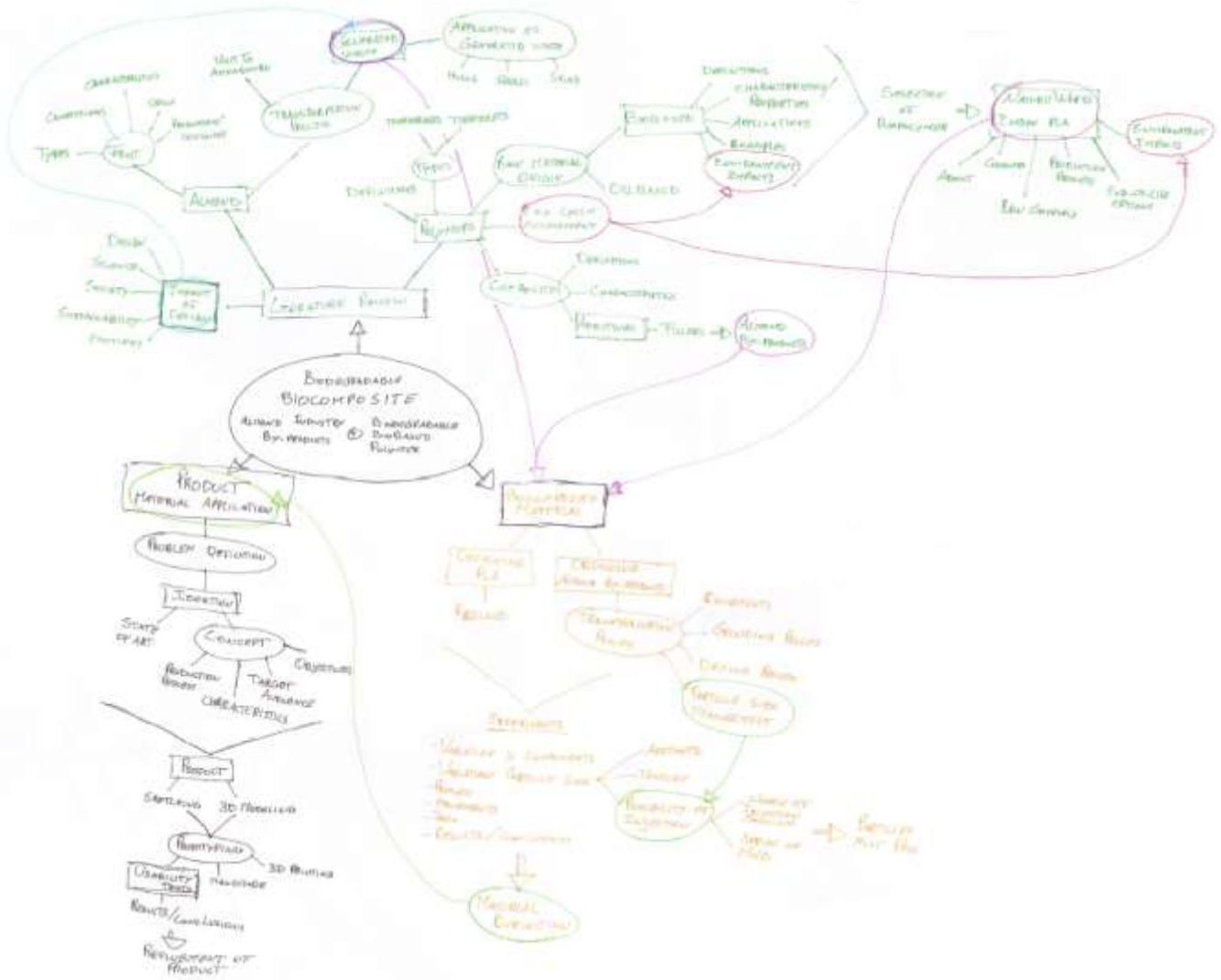


Figure 2: Mind map created for this work.

Regarding the mind map, a long literature review of books on related subjects, accessing and searching scientific papers in ScienceDirect, NDLTD and FEUP Catalogue was undertaken. Some reliable websites have also been accessed in order to cover any other missing information. With the information almost gathered, it was analysed and compiled to allow a better understating and knowledge improvement about the subject. Followed by this, some experiments were performed using the PLA and the reinforcement in the Faculty of Engineering of University of Porto (FEUP) facilities with the available equipment, by testing different mixtures and different processes in order to try to achieve the expected results for the material. Finally, using some design principles, knowledge acquired during faculty and software CAD, such as *SolidWorks* and *Autodesk Inventor*, concepts were developed and tested and validated through prototypes.

## 1.6. Structure of dissertation

This dissertation is divided in four big chapters: introduction, state of art, case study and conclusions.

As far as the introduction is concerned, the main issues presented include the motivation for the realization of this dissertation, contextualization with the theme, definition of the objectives and methodology.

Regarding the state of art, a connection between Design and the subject of the dissertation is here presented. Following, comes the presentation of a deep literature review about almond fruit and polymers, mainly about PLA. Finally, bearing in mind the objectives, some products made from food waste are shown.

The third chapter deals with the case study itself and presents all the equipment, tools and experimental work to obtain a bio-composite composed by PLA, which is the matrix, incorporating almond by-products particles. Then, there is an example of a possible application of the resulting material in a design proposal. Thus, as far as the design proposal is concerned, problem definition, benchmarking, ergonomic study, product development, product validation and renders are presented.

In the very last chapter, there is a whole set of conclusions and study limitations experienced during the whole process that made this dissertation possible. Additionally, some suggestions for future work are also included.

## 2. State of Art



All through this chapter, most of the reviewed literature that was somehow important for this research, will be presented, as well as references to information collected in books from several authors, scientific papers available on Science Direct or NDLTD, or even some reliable websites.

So, firstly, there is an approach to design's importance explained on five topics: design, science, society, sustainability and emotions. The impact design can have on Earth and its environmental sustainability will be considered in each topic.

The topic will deal with almond nuts, almond trees, the culture cycle of almonds and the transformation process in industry, as well as some statistical data. The visit to *Amendouro*, a Portuguese enterprise directed to the production of almond meat will also be mentioned.

Following, there is a presentation of the literature review regarding polymers, bio-based polymers and bio-composites. It is also mentioned information about the *Natureworks*<sup>®</sup>, *Ingeo*<sup>™</sup> PLA, as well as its end-of-life options and life cycle assessment. In the chapter dedicated to bio-composites, there is also reference to additives, highlighting the fillers and taking into consideration the waste of the almond nuts industry.

Finally, the results of the research on products using food waste in which some examples will be shown and explained.

## 2.1. Design and its importance on Earth's sustainability

*"A designer is a human being who tries to cross the narrow bridge between order and chaos, freedom and nihilism, between past achievements and future possibilities"* (adapted from Papanek 1995). *"Design professionals of all stripes are among those best suited by education and profession to provide answers to the questions and solutions for the problems. Design is a process of bringing the imagined into reality. It is art and science, it is technical and creative, it is practical and beautiful"* (Russ 2010). However, *"no design is isolated: the whole design has social, ecological and environmental consequences that need to be evaluated"* (adapted from Papanek 1995).

### 2.1.1. Design – what does it mean?

*"Design is to design a design to produce a design"* (Heskett 2005).

The Industrial Designers Society of America (IDSA) defines Industrial Design as "the professional service of creating products and systems that optimize function, value and appearance for the mutual benefit of user and manufacturer." About Industrial Designers, they "develop products and systems through collection analysis and synthesis of data guided by the special requirements of their client and manufacturer. They prepare clear and concise recommendations through drawings, models and descriptions. Industrial designers improve as well as create, and they often work within multi-disciplinary groups that include management, marketing, engineering and manufacturing specialists" (Industrial Designers Society of America).

Humans usually follow either consciously or unconsciously, a process or framework of every one of their daily actions, not only on their profession but also on their personal tasks; so, design has many and different processes to follow, depending on the author, enterprise, professor, etc. Thus, Poli (2001) defines the design process as "the series of activities by which the information known and recorded about a designed object is added to, refined, modified, or made more or less certain. As design proceeds, the information becomes more complete and more detailed until finally there is sufficient information to perform manufacturing". Most commonly, a design process starts with the definition of a need, which can be a solution for a problem, a desire of a new product, the improvement of an existing product, etc. It is important to mention that the design process can be – and usually is – undertaken with a multidisciplinary team and not only a designer, stimulating the share of knowledge to enrich the development process in order to have more complete solutions.

The design process is very important since it is during the development of a product that decisions are taken regarding its utility and impact – social, economic and environmental. The study field of Design takes into consideration the effects of actions allowing designers to anticipate and assess them during the development of a product within the decision-making process. This requires the designer to seek for understanding of the implications of his decisions in order to present a final solution knowing and expecting the impacts it may have in the future. Considering this, designers cannot ignore and avoid the responsibility of their own actions and keep doing the same things all the time without considering the consequences.



Gordon Russel, director of the Council of Industrial Design – later renamed Design Council – from 1947 to 1959, in the very first issue of the *Design* magazine – Council's monthly magazine – (Design Council 2015) attempted to define “good design” by rhetorically asking what the consumer demands from a product: *“He demands something which is well made of good and suitable materials, which does its job efficiently and gives him pleasure, at a price he can afford to pay. (...) Good design always takes into account the technique of production, the material to be used and the purpose for which the object is wanted”* (Whiteley 1993).

Also, Tracy Bhamra and Vicky Lofthouse, in their book *Design for Sustainability*, wrote that *“good design will ensure a product contains a rationalized number of materials and components; that consumer health and safety issues are considered; that it functions appropriately and effectively and communicates its function clearly; that it is styled appropriately; that is ergonomically correct and complies with legislation requirements”* (Bhamra and Lofthouse 2007).

### 2.1.2. Design and science

*“(..)* the nature of design is its “in-betweenness”: between theory and (...) practice. (...) In short: the traditional sciences are burdened by the frozen norms of so-called “scientific standards” while design theory and research, with their far lighter baggage of modernism, are able to offer a confident and critical debate which other disciplines might well use to further and re-think their understanding of research. The fact that design is continuously oscillating between action (practice) on the one hand, and theory and research on the other – meaning between concrete everyday life and traditional scientific thinking, both of which influence and change each other – has to be considered an opportunity” (Brandes, Wender, and Stich 2013).

The growing awareness of world's environmental problems and the implications of the increasing world population are the result of a deeper scientific understanding of the relationships between human activity and natural processes (Russ 2010). Science has provided people with a deeper and richer understanding of nature and their impact on it, since people were not aware of it in the past because the information being not sufficiently available (Russ 2010). Bearing this in mind, nowadays, people from all ranges of activity have no reasons to continue acting as if they had lack of scientific data or no knowledge about it.

Thus, designers rely and employ scientific knowledge of different areas while developing a new product in order to know what, how, when and why to take specific decisions during product development. It also allows them to create and predict a life cycle in order to expect they had taken the best decision regarding the social, economic and environmental impact the product will have. During the decision-making process, designers will take decisions relying on science that are known to be true at the time, granting confidence to designers that they are taking the best decisions (Russ 2010). However, as science changes over time, so will design decisions because what is a fact and the best decision today, may not be so tomorrow.

### 2.1.3. Design and society

*“In an age of mass production when everything must be planned and designed, design has become the most powerful tool with which man shapes his tools and environments (and, by extension, society and himself). This demands high social and moral responsibility from the designer”* (Whiteley 1993). *“Design is one of the basic characteristics of what it is to be human, and an essential determinant of the quality of human life. It affects everyone in every detail of every aspect of what they do throughout each day”* (Heskett 2005).

Regarding what Papanek wrote, design directly expresses the cultural, social, political and economic complexion of a society (Whiteley 1993). In order to be valuable, designed products must serve the interests of a society, and consequently, the economy, since design can boost existing businesses and create new ones, stimulate sales, economy growth, etc. (Cather et al. 2001). This requires that designers acquire knowledge about the target audience by studying their anthropometry, culture, behaviour, etc. or more specific, study, for example, how disabled people can come across their difficulties (Cather et al. 2001).

Thus, if the designer knows who he is designing for, he will be creating consumer-led design – production of anything that can be fitted into a market – directly interfering in the consumer’s right to choose what the marketplace offers best for the consumer in a free society (Whiteley 1993). However, consumer-led design in a market economy goes far beyond the idea of meeting human needs because it seeks to create and constantly stimulate human desires (Whiteley 1993). J. Gordon Lippincott, wrote in his book *Design for Business*, published in 1947, that the major problem of manufacturers and designers of the time was of continually stimulate the urge to buy, to such an extent that the market was becoming saturated, which is not different from today’s reality (Whiteley 1993).

It is obvious that there is a need to change the attitudes of consumerist societies because the *“planet cannot sustain the continuous economic growth required to fuel a worldwide market economy, especially when linked with a rapidly expanding world population”* (Whiteley 1993). Besides this, there is the need to replace the existing products by environment friendly products, as well as, find a way to change the way consumers take their decisions when choosing a product to buy.

In the late 1980s, the world witnessed a rapid growth of the “Green consumer”, which refers to consumers with ecological ethics and who look for environment friendly products (Whiteley 1993). If people have knowledge about products and their social, economic and environmental impact, this could lead the consumers to demand for ideologically responsible, sustainable and socially acceptable products. The world demands that designers develop a greater awareness of design’s explicit and implicit values and obvious implications, and exercise a greater control of design in our societies because designers and consumers can no longer plead innocence or amorality on their actions (Whiteley 1993).

## 2.1.4. Design and sustainability

*“Instead of controlling the environment for the benefit of the population, perhaps we should control the population to ensure the survival of our environment.”*

David Attenborough

Perhaps the most common definition for sustainability was crafted in 1987 at the World Commission on Environment and Development, often referred to as the Brundtland Commission: *“Development that meets the needs of the present without compromising the ability of future generations to meet their own needs”* (Russ 2010).

Besides this, the definitions from Bhamra and Lofthouse (2007) that follow will help to differentiate some environment design philosophies:

- Green design: focuses on single issues, for example, the inclusion of recycled plastics;
- Ecodesign: environmental issues are considered at each stage of the design process;
- Design for sustainability: design that considers the environment, for example the resource use and end of life impact, and the social impact of a product, for example usability and responsible use.

Russ (2010), on his book *Sustainability and Design Ethics*, wrote: *“The environment, or our current valuation of it, can be described in broad economic terms then as capital and resources. If capital is wealth that we might invest to generate more wealth, then nature provides capital in the form of stocks of materials and services that can be used to generate wealth or from which we might draw utility. Natural resources are generally considered valuable only in terms of how they might be consumed”*.

However, besides the words of Tom Russ, society must recognize that their relationship with the environment must change to preserve their own “natural wealth”. Also, as the data has been accumulated and the observations becoming more obvious and easier to detect, many people have already acknowledged that, indeed, decisions and actions of the society are having a significant and detrimental implications on the environment (Russ 2010).

It is also important that the impacts of production are not only “downstream” (product use and disposal of the waste) but also “upstream” (extraction, processing and manufacturing of materials) (adapted from Peneda and Frazão 1995). While “downstream” environmental impacts are more visible and clear to all, it doesn’t mean that impacts of production “upstream”, regarding the extraction and transportation of raw materials, so less visible, are not less severe (adapted from Peneda and Frazão 1995). Unfortunately, the actual economic system is based on the principle of the exhaustion of natural resources for the purpose of production, consequently entailing the fabrication of waste (Hebel, Wisniewska, and Heisel 2014). Regarding this, *Diário de Notícias*, a Portuguese newspaper, published on its website a news report in which the reader learnt that we have exhausted world’s natural resources on August, 8 this year (Diário de Notícias 2016). From now on, we are consuming more than the Earth’s

production capacity for this year, but this has been happening for some years and exhausting earlier, and earlier year after year (Diário de Notícias 2016). It is clear that almost all resources are finite in nature and even renewable resources can be considered finite if the rate of consumption is unsustainable (Russ 2010). Considering this, we must create a balance between Human consumption and the Earth's natural production process by preserving the interests of the present and bearing in mind the interests of the future in such a way as to realize opportunity within the limitations of the environment in order to have a sustainable society.

Therefore, the concern with ecology involves ethical and social responsibility (Papanek 1995) and also, expresses the reason of design for sustainability being so important. Thus, if design is practised with responsibility, it should be the anvil on which human environment is shaped and constructed for the betterment and delight of all (Heskett 2005); it should be the bridge between human needs, culture and ecology. Moreover, it is considered that "in a paradigm of sustainability the designer must be educator, expert, consensus builder, synthesizer of solutions and servant of the process" (Russ 2010). Since designers are between the manufacturer and consumer, they can have, as abovementioned, a bigger influence over how things are made; the materials that are used; how they are constructed; how efficient they are to use; their ease of maintenance; their recycling/reuse potential; and their capacity to return to nature when they reach the end of the life cycle (Whiteley 1993) – because nature is important not only as a supplier of resources but also as receiver of waste (adapted from Peneda and Frazão 1995).

### 2.1.5. Design and emotions

*"Why design for emotion? If you want your product to be successful, it must be emotional. Emotion dominates our experiences and colours our realities. Because of this, all design is emotional design. Emotion dominates decision-making, commands attention and enhances some memories while minimizing others"* (Gorp and Adams 2012).

Reinhardt Butter and Klaus Krippendorf developed, in the eighties, a theory which introduces the idea that a product carries meanings. According to them, these meanings are constructed on the basis of the intertwined relations among the form, function, colour and all the features (or signs) that compose the product (Karana, Hekkert, and Kandachar 2009). Design professionals already appreciate the importance of evoking emotions and communicating personality to capture viewers' attention and create satisfying experiences (Gorp and Adams 2012). On the last three decades, research examining the relationship between design and emotion has provided new ways to observe the dimensions of emotion, which allow designers to design for emotional responses (Gorp and Adams 2012). Concerning the meanings in product experience, the designer is the sender of the message, in the form of a product, and the consumer is the receiver of that product (Karana, Hekkert, and Kandachar 2009). Then, the consumer's emotions using the product, will indicate if it becomes meaningful or not. Liz Sanders described three categories of product requirements, covering all the aspects of consumers' emotional experiences with products (Gorp and Adams 2012):

- useful – performs the tasks it was designed for;
- usable – easy to use and interact with;
- desirable – provides feelings of pleasure and creates attraction.

In this context, the selection of materials for a product is a key process for its own success, because nowadays, ideal selection of the materials during the design process is not only focused on the fulfilment of technical requirements but also on creating appeal to the consumers' senses and contribute to the intended meaning of a product (Karana, Hekkert, and Kandachar 2010).

Bearing this in mind this, designers and engineers must consider a large number of factors when selecting a material, such as, mechanical properties, magnetic properties, electrical, thermal and radiation properties, surface properties, manufacturing properties, material cost, reliability, durability, recycling ability, impact on environment, fashion, market trends, cultural aspects, aesthetics, etc. (Jahan et al. 2010). The process of selecting a material is very important, even though it is hard and lengthy, not only because there is a great number of materials available but also due to the fact that there is always more than one material suitable for an application. Yet, the final selection will always have pros and cons (Jahan et al. 2010).

Thus, concerns like product experience, pleasure, emotions and others, belong to the domain of design (Karana, Hekkert, and Kandachar 2010). Besides these concerns, designers also need insights about materials in order to use them efficiently if they want to transfer certain meanings (Karana, Hekkert, and Kandachar 2009, 2010). However, designers who intend to create certain meanings through materials of designed products are confronted with the difficulty that there is no one-to-one relationship between material properties and intended meanings (Karana, Hekkert, and Kandachar 2010) because, since all users use the five senses – sight, touch, smell, taste and hearing – to ascribe particular meanings to materials and products, each one will report different experiences when describing the use and technical properties of materials, manufacturing processes, sensorial properties, as well as meanings and emotions when using the product (Karana, Hekkert, and Kandachar 2009).

Finally, regarding plastics, bio-based plastics will create new and/or different meanings when compared to oil-based plastics. The fact that bio-based plastics have a lower footprint, a material that comes from nature and can return to it and with the same aesthetic possibilities, will obviously create different interrelationships between consumers and products other than the ones with oil-based plastics. At this moment, bio-based plastics are seeking for their own identity that will help them to be recognized in the market and make them desirable to be possessed and to be used (Karana 2012).

Taking into consideration all the text abovementioned, if designers want to practice good design, they should consider not only the aesthetics, material, communication, components, cost, efficiency, functionality, etc. of a product but also the impact that the product will have on society and environment. Bearing this in mind, the designer should study and connect science and emotions in such way that a product corresponds to what a user is demanding without creating an unsustainable environment.

## 2.2. Almond fruit

As aforementioned, this research is going to be based on designing a new product using PLA and the waste of almond nuts industry so, to start with, the main aim of this chapter, which is the almond fruit itself. However, before presenting the reviewed literature about the almond, it is interesting to mention that there are papers with good indications on the use of the waste of other nuts, which presents similar characteristics and properties to those of the almond nuts, as fillers in thermoplastics matrices. Bearing such information in mind, below there is a list of the most common edible nuts worldwide (Table 1) from the book *Edible Nuts* by Wickens (1995) and published by the *Food and Agriculture Organization of the United Nations*:

List of edible nuts		
Major edible nuts		
• Almond nut	• Coconut	• Pecan
• Brazil nut	• Hazelnut	• Pistachio
• Cashew nut	• Macadamia nut	• Sunflower seeds
• Chestnut	• Peanut	• Walnut
Minor edible nuts		
• American beechnut	• Pignolia	• Soya bean
• Butternut	• Pumpkin nut	• Water chestnut
• Philippine nut	• Shagbark hickory nut	
Potential edible nuts		
• Areng palm	• Galo (promising nut)	• Pequí
• Argan nut	• Guyana	• Quandong
• Babassu	• Indian almond	• Sapucaia nut
• Bitter cola	• Java almond	• Shea butter tree
• Cacay	• Marula	• Tara
• Egg nut	• Okari nut	• Tucuma
• Chilean nut	• Peach plum	• Yicib

**Table 1:** List of edible nuts (Wickens 1995).

Using some definitions from different sources and Cambridge Online Dictionary, “nut” can be defined as an indehiscent dry fruit that grows in a hard shell, which is generally covered by a thick, fibrous outer hull that is removed during harvest, and can often be eaten – edible nuts.

Now, regarding the subject on study, the almond nut is the fruit grown in almond trees – *Prunus Dulcis*. These species of trees, that was widely introduced in North Africa, Cyprus, Crete, southern Europe, Afghanistan, Kashmir, California, etc. (Wickens 1995), belongs to the Rosaceae family, which also includes apple trees, pear trees, plum trees

and raspberry, and are one of the most popular nut producing trees worldwide, as well as the most widely produced of all nuts fruits (Esfahlan, Jamei, and Esfahlan 2010). Almonds can be hard or soft shelled and they can be either sweet almonds – for the production of edible nuts – or bitter almonds – for the production of oil from bitter almonds (Wickens 1995).

Edible almond nuts are cultivated under a variety of growing conditions and climate conditions, among which California, USA, is the number one in the production of almonds, followed by Australia and Spain – representing, in 2013, 62,2%, 5,48% and 5,11%, respectively (FAOSTAT). This fruit is globally popular and valued for its sensory, nutritional, and health attributes, especially because the regular consumption of almonds has been associated with a reduced risk of chronic diseases (Esfahlan, Jamei, and Esfahlan 2010).

The almond fruit can be separated into four parts, from its core and outwards: kernel or meat, brown skin of meat or seed coat, almond shell or middle shell and almond hull or outer green shell cover as it can be learned below (Esfahlan, Jamei, and Esfahlan 2010):

- Almond meat or kernel

This is the most important part of the almond fruit due to its nutritional properties (Esfahlan, Jamei, and Esfahlan 2010), such as vitamin E, manganese, copper, vitamin B2, phosphorus and magnesium (The George Mateljan Foundation). Almond meat (Figure 3) can usually be found in many food applications, as for example, snack foods, chocolates, granola and as ingredient in a variety of processed foods, especially in bakery.



**Figure 3:** Example of an almond kernel, with and without skin (Eu Como Sim).

- Almond brown skin or seed coat

Almond meat is encased in a brown leathery coating, known as seed coat, which protects the almond from oxidation and microbial contamination and represents 4% of the almond fruit (Esfahlan, Jamei, and Esfahlan 2010). Almond skins (Figure 4) are agricultural by-products that are a source of phenolic compounds and are produced upon the processing of almonds in large amounts, since many food applications of almonds require the kernel without the seed coat (Esfahlan, Jamei, and Esfahlan 2010). Almond skins can be removed with a hot water blanching process and can later be used to livestock feed or incinerated as biomass fuel to produce heat or electricity in processing plants (Esfahlan, Jamei, and Esfahlan 2010).



**Figure 4:** Example of almond skin after almonds being peeled (Lemberona).

- Almond shell or middle shell

The almond shell (Figure 5) is the ligneous material forming the thick endocarp of the almond fruit, which is another by-product – in the form of big fragments – of the almond industry when the fruit is processed with the objective of obtaining almond meat either with or without the skin (Esfahlan, Jamei, and Esfahlan 2010). The main chemical composition of almond shells is hemicellulose ( $\approx 29\%$  to  $32\%$ ), cellulose ( $\approx 37\%$  to  $51\%$ ) and lignin ( $\approx 20\%$  to  $27\%$ ) (Chiou et al. 2016; Energy research Centre of the Netherlands - Phyllis2 2002; Caballero, Font, and Marcilla 1996). Unfortunately, this almond fruit by-product becomes mere waste without any important industrial use. This means that it may also be used as livestock feed, though most of the time incinerated to produce heat or electricity, or even dumped. However, almond shells have a high content of xylan, making them suitable for the production of xylose furfural or for fractioning into cellulose, pentosans and lignin (Esfahlan, Jamei, and Esfahlan 2010). Besides this, a paper reports that shells of almond, apricot, hazelnut, peach and walnut have many cavities with a higher number of concentric layers, which make these shells very important to use as fillers in polymer matrices (Zaikov and Jimenez 2011).



**Figure 5:** Almonds in shell (Nuts).

- Almond hull or outer green shell cover

The almond hull (Figure 6) – the mesocarp of almond fruit – protects all the other parts during the growth of the fruit from the intense heat, ultraviolet radiation, pest infestation and others (Esfahlan, Jamei, and Esfahlan 2010). When it becomes mature, the mesocarp becomes dry, leathery, with  $8\%$  to  $20\%$  of moisture (Esfahlan, Jamei, and Esfahlan 2010) thus indicating the fruit is prepared for harvesting. The hulls also contain insoluble fibres, composed of cellulose, hemicellulose, pectins, tannin-like complex polyphenols, and ash, making them suitable as sweetener and dietary fibre (Esfahlan, Jamei, and Esfahlan 2010). Also, as dry hulls and another almond by-product, they represent a potential source for food or food additives, pharmaceuticals, supplemental



livestock feed and cat litter (Esfahlan, Jamei, and Esfahlan 2010). However, as it happens with almond skins and shells residues, hulls are usually incinerated with skins and shells, so these residues have no particularly positive industrial interest.



**Figure 6:** Almonds in shell and hull, which is already mature and dried (Hilltop Ranch).

In 2013, in a total area of 1.637.243 ha, the entire worldwide production of almonds, with shells included, represented 2.917.894 tonnes, of which 1.094.714 tonnes corresponded to almond kernel (FAOSTAT; International Nut and Dried Fruit Council Foundation 2015), and the remaining 1.823.180 tonnes to the almond by-products. Thy et al, in their paper, wrote that dairies have reported paying more than \$110 per tonne (Aktas et al. 2015), which is approximately 0,097€ per kg. Besides this, according to the information collected at *Amendouro*, a Portuguese enterprise dedicated to the production of almond meat, the shells and hulls resulting from their production of almond meat, could be sold between 0,075€ and 0,1€ per kg, depending on the season.

### 2.2.1. Almond's culture cycle

There are different types of almonds and also different almond culture cycles. Nevertheless, they don't differ that much from one another. In this chapter information from *California Almonds* website will be used to mention a possible almond culture cycle, which is similar to Portugal's almond culture cycle.

Considering this, after harvest, which usually ends in October, almond trees go through a period of dormancy, from November to February, to relax and recover the nutrients for the next year's crop (California Almonds). After this period, and until early March, the trees' buds start the blossoming of light pink and white blooms in preparation for pollination (California Almonds). Many almond trees are not self-pollinating, so cultivators bring populations of bees to the orchards to carry the pollen and start the crop development (California Almonds). From March to June, almonds grow to mature, with hardening of the shell and growth of the almond meat. During this time, some immature almonds are harvested so that they can be used with specific culinary purposes (California Almonds). During July and early August, the almond hulls start to split open, exposing the almond shell, making it possible to dry naturally. Just before harvest, between mid-August and October, the hulls get completely open (California Almonds). The harvest is usually made by specific proper machines and equipment known as *tree shakers*, which by shaking the almond trees cause the almond fruits to fall into canvas sheets to get collected (Wickens 1995). These machines can be

equipped with hulling equipment to remove the hulls from the almonds at the moment of collection (Wickens 1995). The harvest can also be made manually yet this technic is obviously not profitable for cultivators. After harvest, the almonds are transported to factories to be processed so that the kernel of almond fruits can be obtained.

### 2.2.2. Almond's transformation process – visit to *Amendouro*

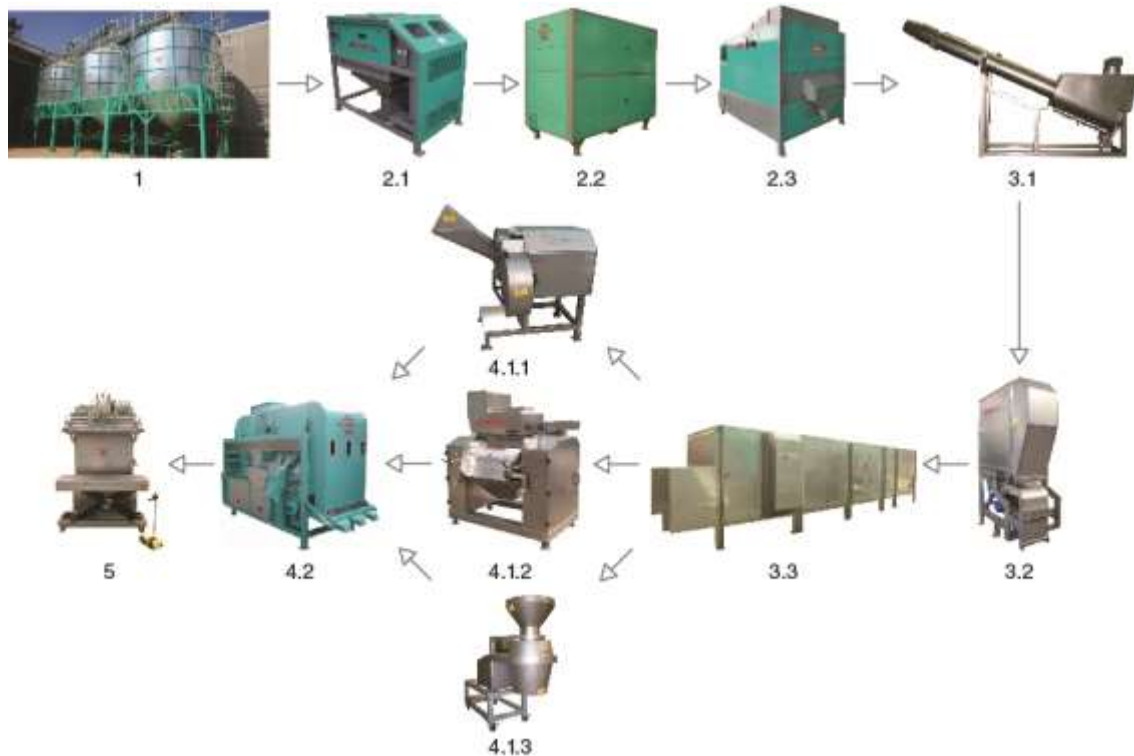
*Amendouro*, as abovementioned, is an enterprise which is directed to the production of almond meat. This visit was very pertinent to understand and learn more about how almond is produced and what happens to their almond by-products. Bearing this in mind, according to the information gathered there, the next few lines will deal with the transformation process of almonds. Additionally, the almond by-products were collected and provided by them at this visit.

This enterprise, founded in 1989 in *Alfândega da Fé*, Portugal, is dedicated to the processing and preparation of almonds. Besides processing almonds produced in Portugal, they also import almond in shell, either with or without hull, from California and Spain, as the amount of almond production in Portugal is not enough to meet the producer's needs. *Amendouro* sell their products in different countries, such as Portugal, Brazil, Belgium and Germany.

*Amendouro* is equipped with machines of *Jose Borrell S.A.*, who manufactures equipment for hulling, shelling and processing of almonds, hazelnuts and other tree nuts (*Jose Borrell S.A.*). Unfortunately, *Amendouro* did not allow a photographic record of the visit to illustrate the almond processing cycle adopted by them. However, considering the visit to the processing line of *Amendouro*, their website and with the help of *Jose Borrell S.A.*, which has been contacted to provide images of the equipment or similar to it in *Amendouro's* factory, is presented below by phases and by illustrated scheme (Figure 7):

1. Storage: as soon as the almond sacks are received, the almonds are placed in proper containers to go through the processing line;
2. Hulling and/or shelling: almonds are conducted from the containers to machines that will remove the hulls and/or shells, extracting the kernel with the skin;
3. Blanching, peeling and drying: *Amendouro* sells almonds both with and without the skin of the kernel. If the option is to remove the skin, almonds are emerged into hot water and the skin is then removed by friction. After this, the kernel must follow into a drying stage. It is important to mention that the enterprise uses hulls and shells to heat their boilers by combustion.
4. Slicing, slivering, dicing and milling: almonds, blanched or natural, can be sold with the whole kernel or in different sizes and shapes. Thus, *Amendouro* present the following products not counting with almond (in shell): natural almond, natural almond powder, blanched almond, blanched sliced almond, blanched slivered almond, blanched diced almond and blanched almond powder;
5. Mass measurement and packaging: at this stage, the products are prepared and ready to sell;

6. Holding room: finally, the packages are placed in an appropriate room in order to be kept in perfect conditions before delivery.



**Figure 7:** Example of an almond processing line by the steps abovementioned: 1. Containers/silos; 2.1. Rotary huller; 2.2. Shell cracker; 2.3. Smart sorter; 3.1. Steam scalding machine; 3.2. Blancher; 3.3. Continuous belt dryer; 4.1.1. Dicing machine; 4.1.2. Flour milling machine; 4.1.3. Slicer; 4.2. Compact separator; 5. Vacuum packaging machine (adapted from Jose Borrell S.A.).

### 2.2.3. Almond's industry waste possible applications

Agro-industry residues are the most easily accessible and, often, least costly form of biomass available today (González et al. 2006). In 2013, as aforementioned, considering the almond industry, 1.823.180 tonnes of residues were then produced. These, as well as other agricultural residues, have not received enough attention, and most of them end up being incinerated and used as biomass fuel, to produce heat and generate electricity or dumped without control, thus causing several environmental problems or even used as animal feedstock. At *Amendouro*, as already mentioned, the boilers are heated with the incineration of their own residues, making the greatest possible benefit of their by-products. Also, their customers who buy the almond residues usually use them for combustion, too. Biomass fuels are more environmentally friendly in terms of heat and power generation, since they have a closed carbon loop, low sulphur dioxide emissions, good opportunities of ash utilisation and potential to save fossil energy resources (González et al. 2006). However, the fact is that there are already many studies on the use of almond hulls, shells and skins, and many other agricultural residues, with enough indicators to motivate manufacturers to go further on these studies and apply such residues in their products. In sequence, some studies using almonds residues reported by investigators will be mentioned within the next few lines.

- In their work, Essabir et al. (2013), used almond shell particles as reinforcement in a polypropylene (PP) matrix. They investigated the composites with and without a compatibilizer for different particle content (5, 10, 15, 20, 25, 30%) to evaluate their mechanical, thermal and rheological properties. The results showed a clear improvement in mechanical and rheological properties from the use of almond shells particles in the matrix either without or with the maleic anhydride compatibilizer, corresponding to a gain in Young's modulus of 56,2% and 35% respectively, at 30% particle loading. The thermal analysis revealed that incorporation of particle in the composites resulted in increase in the initial thermal decomposition temperatures.
- Pirayesh and Khazaeian (2012) investigated the incorporation of almond shell particles, in different ratios, in a wood based composite using urea-formaldehyde resin. They concluded that the addition of almond shell particles greatly improved the water resistance of the panels but flexural properties and internal bond strength decreased with the increasing almond shell particle content. Finally, in order to meet the standard required for mechanical properties, the amount of almond shell particles should, at most, be 30% in the mixture.
- González et al. (2005) evaluated the efficiency of the incineration process of almond residues in a 12kW mural boiler for domestic heating by comparing it with a forest pellet recommended by the boiler manufacturer. The results showed efficiencies of 88,3%, 85%, 78,5% and 90,5%, for almond hulls, almond shells, almond skin and forest pellets, respectively.
- Ledbetter (2008) wrote that almond shells have been used as organic inclusions in porous ceramic bodies for textile engineering and drug delivery systems applications and as an additive to "driller's mud" to reduce the chance of equipment sticking during the drilling of new wells.
- Finally, Esfahlan, Jamei, and Esfahlan (2010), mentioned in their paper some confirmed potential uses for almond shells, such as heavy metals absorbent – metals are among the most important pollutants on surface and ground waters, so their elimination from water is important to protect public health; as dyes absorbent – textile industry produces a large volume of polluted effluents by discharging synthetic dyes, the most important hazardous material found in textile effluents, which need to be eliminated also; as growing media – almond shell used 100% pure as growing media for soilless culture can be more environment friendly and less expensive than the traditional rockwool, since it needs to be produced. The authors referred that in a study made by other investigators, the crop of tomato consumed less 21% water using almond shells as growing media than using rockwool; as a rich source in preparing activated carbons – these have been widely used as absorbents in the separation and purification processes for gaseous or aqueous solution system and used as a catalyst or a catalyst support in the catalytic process, making them very important for chemical, pharmaceutical and food industries.

## 2.3. Polymeric materials

Similar to the previous chapter, it was already defined to use PLA, a bio-based thermoplastic polymer for the matrix to be reinforced with almond nuts waste. Considering this, it was made a research starting with the main topic, polymers and, from this, specifying the research until the PLA from *NatureWorks*<sup>®</sup> that is going to be used on the experiments.

A polymer is defined as a long-chain molecule containing one or more repeating units of atoms, joined together by strong covalent bonds and a large collection of these molecules of similar chemical structure is known as polymer or as plastic (Mallick 2007). In the solid state, these molecules are frozen in space, either in a random chemical structure in amorphous polymers or in a mixture of random chemical structure (folded chains) in semicrystalline polymers (Mallick 2007). In the liquid state, the molecules can move to the intended configuration by reorganizing their chemical structure when getting into solid state.

Bearing this information in mind, polymers are divided into two main categories: thermoplastics and thermosets. On the one hand, in a thermoplastic polymer, individual molecules are not chemically joined together, being held in place by weak secondary bonds or intermolecular forces, such as Van der Waals bonds and hydrogen bonds (Mallick 2007). By heating a solid thermoplastic polymer these secondary bonds can be temporarily broken and the molecules can now be moved relatively to each other or flow to a new configuration with the help of pressure, while during the cooling process, the molecules get frozen in their new configuration and secondary bonds are restored, resulting in a new solid shape (Mallick 2007). Thus, a thermoplastic polymer can be heat-softened, melted, and reshaped as many times as desired (Mallick 2007) without severe damage to its core structure, allowing reprocessing and recycling. On the other hand, in a thermoset polymer, the molecules are chemically joined together by cross-links, forming a rigid, three-dimensional network structure and once these cross-links are formed during the polymerization reaction, the thermoset polymer cannot be melted by the application of heat (Mallick 2007). However, if the number of crosslinks is low, it may still be possible to soften them at high temperatures (Mallick 2007). Thus, thermoplastics are usually more interesting for manufacturers and actually represent consumption of roughly 80% or more of the total plastic consumption (Biron 2013).

As far as thermoplastics are concerned and as PLA belongs to that group, it proves appropriate to present a set of some advantages and disadvantages of their use (Biron 2013):

### Advantages

- Softening or melting by heating the material allows welding and thermoforming;
- Processing cycles are very short because of the absence of the chemical reaction of crosslinking;
- Processing is easier to monitor because there is only a physical transformation;

- Thermoplastics do not release gases or water vapour if they are correctly dried before processing;
- Waste is partially reusable as virgin matter because of the reversibility of the physical softening or melting.

#### Disadvantages

- Rising the temperature of the material will decrease the modulus retention due to the absence of chemical links between macromolecules;
- For the same reason, the creep and relaxation behaviours are not as good as for the thermosets;
- There are few materials workable in the liquid state.

### 2.3.1. Bio-based polymeric materials

In view of the research subject, a deep research about bio-based polymers was made. Remembering the contextualization and objectives of this dissertation, the setting point was to follow a zero-waste philosophy for the product to be designed. In this context, oil-based polymers should be avoided due to the fact that their source is a non-renewable material and the bio-based polymer should also be biodegradable, as PLA actually is, allowing to conserve and recover all resources without threatening the Earth's sustainability, as soon as the product reaches its end-of-life cycle.

Bearing this purpose in mind, many and different, yet somewhat similar definitions were found for terms like bio-based, bio-polymer, degradable, biodegradable, compostable, etc. which appear to have multiple and overlapping meanings, showing that a consensus over the exact definition for these terms does not exist.

Thus, "bio-based" is a term focused on the origin of the raw materials, which are defined as renewable raw materials if fully generated from natural procedures at rates comparable or faster than their rate of consumption (Niaounakis 2013a). So, this term is applied to polymers derived from renewable resources. Moreover, the American Society for Testing and Materials (ASTM) defines a bio-based material as "an organic material in which carbon is derived from a renewable resource via biological processes, which include materials from all plant and animal mass derived from carbon dioxide recently fixed via photosynthesis, per definition of a renewable resource" (Niaounakis 2013a).

As far as bio-based polymers are concerned, also known as bio-polymers, Niaounakis (2013a), in his book *Biopolymers: Processing and Products*, states that "bio-polymers are defined as polymers that are derived from renewable resources, as well as biological and fossil-based biodegradable polymers." Also, *Business-NGO Working Group for Safer Chemicals and Sustainable Materials* defines bio-based plastics as "plastics in which 100% of the carbon is derived from renewable agricultural and forestry resources such as corn starch, soybean protein and cellulose" and the US Department of Agriculture defines bio-based polymers as "commercial or industrial goods, (other than feed or food), composed in whole or in significant part of biological products, forestry material, or renewable domestic agricultural materials, including plant, animal or marine

materials” (Álvarez-Chávez et al. 2012). With these definitions for bio-polymers it is possible to understand the meaning of a bio-based polymer but despite being similar and understandable, they all use different definitions for the same term.

Besides this, according to European Bioplastics, a polymer is considered “bio” if it is either bio-based, biodegradable, or both (Niaounakis 2013a). Thus, a bio-polymer will depend on the origin of its raw material and/or its biodegradability. Regarding this, a bio-polymer may be (Niaounakis 2013a):

- A. made from renewable raw materials (bio-based), and being biodegradable;
- B. made from renewable raw materials (bio-based), and not being biodegradable;
- C. bio-polymers made from fossil fuels, and being biodegradable.

According to the information from the previous paragraph, there are more definitions to know in order to better understand and distinguish some of the terms used from one another, such as:

- Degradable – “A material is called degradable with respect to specific environmental conditions if it undergoes a degradation to a specific extent within a given time measured by specific standard test methods [ASTM, ISO, and CEN]” (Krzan et al. 2006).
- Degradable plastic – “Plastic designed to undergo a significant change in its chemical structure under specific environmental conditions resulting in a loss of some properties that may vary as measured by standard test methods appropriate to the plastic and the application in a period of time that determines its classification [ASTM and ISO]” (Krzan et al. 2006). Considering this definition, a polymer may be degradable but not biodegradable.
- Biodegradable – “Capable of undergoing decomposition into carbon dioxide, methane, water, inorganic compounds, or biomass in which the predominant mechanism is the enzymatic action of microorganisms, that can be measured by standardized tests, in a specified period of time, reflecting available disposal condition [ASTM]; or, potential of a material to be degraded which is caused by biological activity especially by enzymatic action leading to a significant change of the chemical structure of the material [CEN]” (Krzan et al. 2006).
- Biodegradable plastic – “A degradable plastic in which the degradation results from the action of naturally occurring microorganisms such as bacteria, fungi and algae [ASTM]” within a specific period of time and environment (Krzan et al. 2006). Important to refer that the biodegradability of plastics depends on the nature of the chemical structure and not on the source, for example, 100% bio-based PE is not biodegradable while 100% oil-based PBAT is biodegradable (Reddy et al. 2013).
- Compostable – “Degradation by biological processes during composting to yield carbon dioxide, water, inorganic compounds and biomass at a rate consistent with other known compostable materials and leave no visually distinguishable or toxic residues [ASTM and ISO]; or, capable of undergoing biological decomposition in a compost site, to the extent that they are not visually distinguishable and break down to carbon dioxide, water, inorganic compounds,

and biomass, at a rate consistent with known compostable materials” (Krzan et al. 2006).

- Compostable plastic – “A plastic which is capable of undergoing biological decomposition in a compost site as part of an available program, such that the plastic is not visually distinguishable and breaks down to carbon dioxide, water, inorganic compounds, and biomass at a rate consistent with known compostable materials and leave no toxic residue [ASTM]” (Niaounakis 2013a). It is the rate of biodegradation, disintegration, and toxicity that determines the difference between biodegradable polymers and compostable polymers, and also, all compostable polymers are by default biodegradable but not vice versa (Niaounakis 2013a).

Besides these definitions, there are other definitions for other types of degradation for plastics that are less used or heard about but not less important, such as, photodegradable plastic – degradation results from the action of natural daylight [ASTM and ISO]; oxidatively degradable plastic – degradation results from oxidation [ASTM and ISO]; hydrolytically degradable plastic – degradation results from hydrolysis [ASTM and ISO] (Krzan et al. 2006); and, bio-resorbable bio-polymers – polymers that can be reabsorbed into body or blood plasma – these polymers belong to the category of biodegradable and/or hydrolytically degradable plastic (Sastri 2014).

As mentioned before, plastic materials have unique and innumerable properties which have a lot of applications from simple packaging to complex engineering with very low cost for manufacturers and it is also one of the biggest pollutants on Earth. Taking this into consideration, bio-polymers have important advantages over oil-based plastics since they can biodegrade much faster, may contain fewer toxins and have a smaller carbon footprint, also, bio-plastic is already being used by industries that require high performance plastics.

The tables that follow present some information about bio-polymers that will help to understand some of their characteristics. Table 2, below, presents the classification of bio-polymers based on their origin. Bio-polymers can be obtained from oil, plants, microorganisms and animals, and depending on their chemical structure they can be biodegradable or not.



Classification of bio-polymers				
Biodegradable				Non-biodegradable
Bio-based			Oil-based	Bio-based
Plants	Microorganisms	Animals		
Cellulose and its derivatives (polysaccharide)	PHAs (e.g. P3HB, P4HB, PHBHV, P3HBHH <sub>x</sub> )	Chitin (polysaccharide)	Poly(alkylene dicarboxylate)s (e.g. PBA, PBS, PBSA, PBSE, PEA, PES, PESE, PESA, PPF, PPS, PTA, PTMS, PTSE, PTT)	PE (LDPE, HDPE), PP, PVC
Lignin	PHF	Chitosan (polysaccharide)	PGA	PET, PTT
Starch and its derivatives (monosaccharide)	Bacterial cellulose	Hyaluronan (polysaccharide)	PCL	PU
Alginate (polysaccharide)	Hyaluronan (polysaccharide)	Casein (protein)	POE	PC
Lipids (triglycerides)	Xanthan (polysaccharide)	Whey (protein)	Polyanhydrides	Poly(ether-ester)
Wheat, corn, pea, potato, soy (protein)	Curdlan (polysaccharide)	Albumin (protein)	PPHOS	Polyamides (PA 11, PA 410, PA 610, PA 1010, PA 1012)
Gums (e.g. cis-1, 4-polyisoprene)	Silk (protein)	Keratin, PFF (protein)		Polyester amides
Carrageenan		Leather (protein)		Unsaturated polyesters
PLA (from corn, starch, sugar cane, etc.)				Epoxy
				Phenolic resins

HDPE, high density polyethylen; LDPE, low density polyethylene; P3HB, poly(3-hydroxybutyrate); P3HBHH<sub>x</sub>, poly(3-hydroxybutyrate-co-3-hydroxyhexanoate); P4HB, poly(4-hydroxybutyrate); PBA, poly(butylene adipate); PBS, poly(butylene succinate); PBSA, poly(butylene succinate-co-adipate); PBSE, poly(butylene sebacate); PC, polycarbonate; PCL, poly(ε-caprolactone); PE, polyethylene; PEA, poly(ethylene adipate); PES, poly(ethylene succinate); PESA, poly(ethylene succinate-co-adipate); PESE, poly(ethylene sebacate); PET, poly(ethylene terephthalate); PFF, poultry feather fibre; PGA, poly(glycolic acid); polyglycolide; PHA, polyhydroxyalkanoate; PHBHV, poly(3-hydroxybutyrate-co-3-hydroxyvalerate); PHF, polyhydroxy fatty acid; PHH, poly(3-hydroxyhexanoate); PLA, poly(lactic acid), polylactide; POE, poly(ortho ester); PP, polypropylene; PPF, poly(propylene fumarate); PPHOS, polyphosphazenes; PPS poly(propylene succinate); PTA, poly(tetramethylene adipate); PTMS, poly(tetramethylene succinate); PTSE, poly(tetramethylene sebacate); PTT, poly(trimethylene terephthalate); PVC, poly(vinyl chloride); PVOH, poly(vinyl alcohol); PU, polyurethane.

\*Acetyl celulose (AcC) is either biodegradable or non-biodegradable, depending on the degree of acetylation. AcCs with a low acetylation can be degraded, while those with high substitution ratios are non-biodegradable.

**Table 2:** Classification of bio-polymers based on their origin (Niaounakis 2013a).

*NaturePlast*, an enterprise specialized in accompanying plastic converters and outsourcers who want to develop and integrate products or packaging into bio-plastics, believes that considering the technological advances, all bio-plastics will be derived from non-food biomass in a near future and its production process will become more sustainable and environment friendly with the use of renewable energies and biorefineries (NaturePlast 2016c).

Table 3 presents some information about some bio-polymers from *NaturePlast*, making it possible to compare and distinguish the main properties of some bio-polymers or groups of them, as for example, PLA and bio-composites.

Overall properties for bio-polymers				
Materials	Type of bio-plastic	Resources	Properties	Applications
Bio-based non-biodegradable polymers	30% to $\approx$ 100% bio-based	Sugarcane, molasses, bio-based oils	Equivalent to common polymers	All type of packaging, technical products, etc.
Bio-composites	Mainly bio-based and can be biodegradable and compostable	Wood, hemp, linen, bamboo fibres and bio-plastic matrix	Stiff, good mechanical and thermal properties, easy processability	Leisure and sport, habitat, horticulture, etc.
Bio-elastomers	Partially bio-based and/or 100% compostable	Mainly petroleum	Very soft, good mechanical properties and easy processability	Leisure and sport, molded products, etc.
Bio-polyesters	Partially bio-based and 100% compostable	Mainly petroleum	Opaque to translucent, stiff to soft, good thermal resistance and easy processability	Bags, mulch films, bottles, molded products, etc.
Cellulose derivatives	Mainly bio-based and can be biodegradable and compostable	Wood pulp	Transparent, stiff, good barrier, mechanical and thermal properties	Food packaging (films), molded products, etc.
PHAs	$\approx$ 100% bio-based and 100% compostable	Corn starch, sugar, etc.	Opaque to translucent, stiff to elastomeric, good thermal and barrier properties	Packaging films, molded products, bio-composites, etc.
PLA	$\approx$ 100% bio-based and 100% compostable	Corn, starch, sugar cane, etc.	Transparent, stiff, easy processability, poor thermal resistance, poor barrier properties	Food packaging, molded products, bio-composites, etc.
Starch based compounds	Can be partially bio-based, biodegradable and compostable	Starch, meals, petroleum	Soft, easy processability, water sensitive and controlled biodegradation	Bags, mulch films, horticulture, etc.

**Table 3:** Comparison of overall properties of some bio-polymers (adapted from NaturePlast 2016d).

The last table (Table 4) is related to the origin of some bio-polymers and raw materials, their applications and main properties. Considering their properties, it is interesting to analyse a table where it is possible to compare some properties of some bio-polymers, both bio and oil-based in deeper detail.

Property	Unit	PLLA	PLA	P3HB	P4HB	PGA	PLGA	PCL
Density	g/cm <sup>3</sup>	1.25	1.26	1.25	1.2 – 1.3	1.5 – 1.7	0.75	0.8 – 1.1
Glass transition temperature	°C	50 – 55	55 – 60	1	– 51	35 – 40	45 – 50	– 60
Melting point	°C	170 – 180	173 – 178	170 – 180	60	224 – 230	70 – 80	60
Tensile strength at break	MPa	40 – 70	29 – 50	36	50	890	41 – 55	5.17 – 29.0
Elongation at break	%	6 – 12	6	3	6 – 25	30	3 – 10	650 – 800
Flexural modulus	GPa	2 – 4	1 – 3	1 – 3	1 – 2	5 – 7	1 – 3	0.2 – 0.5
Impact strength notched, 23°C	J/m	10 – 15	15 – 135	35 – 60	–	–	–	120 – 375
Processing temperature	°C	180 – 190	180 – 200	180 – 190	60 – 75	220 – 240	80 – 100	80 – 100
Degradation rate	Months	18 – 60	< 24	2 – 18	2 – 12	0.5 – 1.5	1 – 6	24
Morphology		C	A	C	C	C	A	C
C = Crystalline; A = Amorphous								

**Table 4:** Properties of some bio-polymers (Sastri 2014).

In terms of sustainability improvements of bio-based plastic relatively to oil-based plastic, the difference between them is notable. Table 5 below shows how much less energy for production of the stated bio-polymers is needed when compared to oil-based plastics in overall.

Bio-plastic	Sustainability improvement
PLA	Production uses 30% to 50% less fossil energy and generates 50% to 70% less CO <sub>2</sub> emissions than oil-based polymers
TPS	Production uses 68% less fossil energy and generates 68% less CO <sub>2</sub> emissions than oil-based polymers
Bio-urethanes (BURs)	Production uses 23% less fossil energy and generates 36% less CO <sub>2</sub> emissions than oil-based polymers
Poly(trimethylene-terephthalate) PTT	Production uses 26% to 50% less energy than oil-based polymers

**Table 5:** Sustainability improvements of bio-based plastics relative to oil-based plastic (Álvarez-Chávez et al. 2012).

According to the data from the tables presented above, the reason why this generation of plastic brought new and good perspectives about the future of Earth, as far as plastic is concerned is easily perceived even more if we consider that biodegradable plastics have dominated the bio-based plastic market with a roughly 90% market share (Soroudi and Jakubowicz 2013). Nevertheless, the market is changing and bio-plastics start registering an increasing rate of production and consumption, also when considering that almost all oil-based plastics can be replaced by bio-based plastics. According to European Bioplastics, the production capacity for bio-plastics is predicted to increase from approximately 700.000 tonnes in 2010 to 1,7 million tonnes by 2015 (Soroudi and Jakubowicz 2013).

Moreover, they can be implemented on conventional processing equipment – extrusion, bottle blowing, thermoforming, injection molding and machining – without many modifications on it (NaturePlast 2016b). These processing equipment allow to make products such as, food films, trays, bowls, cosmetic tubes, pill bottles, syringes, bags, textile, foam, flowerpots, clothing, electronic, and many others (NaturePlast 2016b).

All and all, bio-based plastic has far too many advantages as stated by NaturePlast (2016a):

- Ecological
  - Anticipation of fossil resources depletion;
  - Most bio-plastics are derived from annually renewable plant resources (and soon from by-products and wastes);
  - New end-of-life option for some of bio-polymers (composting);
  - Reduced carbon footprint and the use of fossil resources.
- Economics
  - Increasing costs of fossil resources;
  - Bio-plastics cost reduction through increasing production capacity;
  - Lower taxes and future European Directives.

- Innovation
  - Raising public awareness towards environmental problems;
  - Strong marketing arguments;
  - Being active on the issue of sustainable development;
  - Demarcation of the product compared when to competitors;
  - Upgrading of the product through its packaging;
  - Recognition of the product by the consumer.

### 2.3.1.1. PLA

Poly(lactic acid) or polylactic acid or polylactide, also known as PLA, is an aliphatic polyester produced from lactic acid (Kolstad et al. 2012) and the lactic acid structure can also result in different forms of polylactide, such as, poly(L-lactide) (PLLA), poly(D-lactide) (PDLA) and poly(DL-lactide) (PDLLA) which are synthesized from the L-, D- and DL- lactic acid monomers, respectively, or from the corresponding L,L-lactide, D,D-lactide and D,L-lactide (Reddy et al. 2013). Besides these, crystalline PLA can be obtained with less than 2% of D- content, semi-crystalline PLA is obtained between 2% and 20% of D- content, while amorphous PLA requires D- content over 20% (Reddy et al. 2013).

*NatureWorks*<sup>®</sup> from USA is the biggest producer of PLA from corn, and *Mitsui Chemicals*, *Mitsubishi*, *Shimadzu*, *Toyota* and *Dainippon Ink Chemicals* from Japan, *Futero* from Belgium, *Biomer* from Germany and *Purac* from the Netherlands also produce PLA (Reddy et al. 2013). This polymer has in fact, a higher manufacturing cost when compared to oil-based polymers but this cost has been dwindling due to technological advance, thus becoming more easily available and cost-competitive with most of the polymers.

PLA has been receiving increased attention due to its natural biodegradability, so it is also compostable, besides being a thermoplastic produced from annually renewable resources, which can reduce the consumption of non-renewable petrochemicals. However, the sustainability of PLA, and other bio-polymers, is highly very questionable. The following text may sound contradictory yet after reading chapter 2.3.1.1.1, which is about *Ingeo*<sup>™</sup> PLA, the reason why its sustainability is questionable will be understandable even if it is more environment friendly than oil-based polymers.

From all that has been written before regarding bio-based polymers it may sound that these plastics are fully environment friendly when compared to oil-based polymers but, as abovementioned in chapter 1.2, scientists at the University of Massachusetts-Lowell concluded, from their research, that “none of the bio-based plastics currently in commercial use or under development are fully sustainable” (Elvin 2015) due to some unavoidable factors. Considering only PLA, yet applicable to many others not dealt with in this text, it can be produced from various feedstocks, all of which are essential to make it competitive with oil-based polymers (Yates and Barlow 2013). However, some of these feedstocks are associated with considerable environmental burdens, since

they are generally grown using methods of industrial agricultural production and therefore with significant amounts of toxic pesticides used that have huge impact in the environment (Yates and Barlow 2013). Adding to this, there is the use of significant amount of fossil energy, water and hazardous chemicals, genetically modified organisms and even nanomaterials when the feedstocks are processed to produce bio-based plastic (Álvarez-Chávez et al. 2012). In addition, the land needed for production of bio-based plastics may compete with land needed to grow food for human consumption (Álvarez-Chávez et al. 2012), even more if we consider their vulnerability to crop failure due to flooding or drought (Yates and Barlow 2013). Additionally, Yates and Barlow (2013) wrote in their paper that some authors stated that with the high growth rate of consumption of bio-polymers, there may be some conflict of interest with bioenergy crops around 2050 and they also have predicted that all crop and grazing land, and cleared forest land would not be sufficient to meet the demand for food, liquid fuels, and plastics (assuming all fuels and plastics are derived from agricultural products due to exhaustion of fossil resources) in 2050 in a high consumption, versus low productivity scenario.

For these factors, bio-based polymers can be questionable regarding sustainability. Nevertheless, according to the literature review about *NatureWorks® Ingeo™* PLA this is not applicable, as explained on the following chapter.

#### 2.3.1.1.1. *NatureWorks® Ingeo™* PLA

Almost all information in this chapter is from *NatureWorks®*, an independent enterprise that resulted from a *Cargill* research project and invested in by them and *PPL Global Chemical (NatureWorks LLC 2016a)*. *NatureWorks®* is the first enterprise to offer a family of commercially available bio-polymers derived from 100% annually renewable resources with cost and performance that competes with oil-based polymers (NatureWorks LLC 2016a). Thus, their mission is dedicated to meet the world's needs of today without compromising the Earth's ability to meet the needs of tomorrow by applying their unique technology to process natural sugar plants to create a polylactide polymer marketed under the *Ingeo™* brand name (NatureWorks LLC 2016a). *NatureWorks®* manufacturing facility in Blair, Nebraska, USA, came online in 2002 and, more recently, it was announced a new manufacturing facility in Thailand (NatureWorks LLC 2016a). Besides the information from the manufacturer, some information from *Resinex* is also used. *Resinex* is part of the *Ravago Group*, which is the only supplier of polymers – including *Ingeo™* – covering all Europe countries, with presence in many European countries including Portugal, being their warehouse in Belgium (Resinex 2016a).

In short, *Ingeo™* are bio-based polylactide polymers produced in the US and 100% derived from locally abundant renewable resources (Vink and Davies 2015). *Natureworks® Ingeo™* PLA has a less negative environment impact when compared to many of the existing polymers in the world, since it produces 60% less GHG and uses 50% less of non-renewable energy (Resinex 2016b). The enterprise has different feedstock certification options (Table 6) from Non-governmental Organizations (NGO), brands and certifiers for certifying the sustainability attributes of the current feedstocks

used to manufacture their bio-polymer (Natureworks LLC 2016e). Thus, *Natureworks*<sup>®</sup> has certification for bio-based content, no genetically modified (GM) material in PLA, no genetically modified organisms (GMO) in feedstock and sustainable farming, as the table below shows.

	1 Biobased Content Certification	2 Genescan Certification	3 ISCC PLUS	4 Feedstock Sourcing Certification	5 ISCC PLUS & Feedstock Sourcing	6 Working Landscape Certificates
Biobased content	✓					
No GM material in Ingeo		✓				
Sustainable farming			✓		✓	✓
GMO-free feedstock				✓	✓	
3rd party certified GMO-free feedstock						✓

**Table 6:** Certifications for *Ingeo*<sup>™</sup> (Natureworks LLC 2016e).

The certifications guarantee:

1 – Bio-based Carbon Certification: “Verification that 100% of the carbon in the Ingeo bio-polymer originates from renewable agricultural resources instead of oil. Third-party certification based on ASTM6866 is provided in Europe by Vinçotte and in the US by the USDA’s BioPreferred program” (Natureworks LLC 2016e).

2 – Genescan Certification: “...current US corn growing practices produce a mixed stream of GM and conventional corn. We ensure that *Ingeo*<sup>™</sup> bio-polymer does not contain any GM material at all due to the relatively high heat used in the basic manufacturing process. *Ingeo*<sup>™</sup> is certified to be free of any genetic material by Eurofins GeneScan, recognized by both government and NGOs as the leading authority for testing food, feed and raw materials” (Natureworks LLC 2016e).

3 – ISCC Plus Certification: “International Sustainability & Carbon Certification (ISCC) PLUS is a European based third-party certification scheme (...)”, owned and fully controlled by *Germany-based ISCC Systems GmbH*, “(...) certifying the sustainable production of renewable raw materials including the certification of the chain of custody. ISCC is the world's first state-recognized system for certifying sustainability and greenhouse gas savings. (...) The ISCC certification system is supported by the *German Federal Ministry of Food, Agriculture and Consumer Protection* via the *Agency for Renewable Resources (FNR)*. (...) If a customer wants to participate in this program, *Natureworks*<sup>®</sup> contracts farmers which are then audited and certified (...) by an independent auditor and supervised by *ISCC Systems GmbH*” (Natureworks LLC 2016e).

4 – Feedstock Sourcing Certification: “Since the majority of US corn is genetically modified and it is not economically possible to set up a totally separate production chain dedicated to conventional (non-GM) corn, *Natureworks*<sup>®</sup> offers its feedstock sourcing program for those customers interested in supporting conventional (non-GM)



agricultural practice. In this program a conventional corn volume, equivalent to the customer's needs, is purchased and mixed in the stream entering the corn wet mill. The customer receives copies of the farmer's conventional seed purchase contract and verification that the corn produced is tested and delivered to the corn wet mill" (Natureworks LLC 2016e).

5 – ISCC Plus & Feedstock Sourcing Certification: "Since in today's ISCC PLUS program specification of GM/conventional corn is not a part of the requirements, a combination of *Natureworks*<sup>®</sup>' feedstock sourcing program and the ISCC PLUS program is used. In this way both aspects are covered: conventional corn sourcing combined with sustainable corn production" (Natureworks LLC 2016e).

6 – Working Landscape Certifications: "The US-based NGO, the *Institute of Agriculture and Trade Policy* (IATP), provides the Working Landscapes Certificate (WLC) program; a third-party scheme certifying sustainable agricultural production for emerging biomaterials sectors, including the bio-plastics industry. WLC includes the requirement of using conventional corn seed. Both ISCC PLUS and WLC focus on sustainable farming practices, but have slightly different sets of criteria" (Natureworks LLC 2016e).

Besides these environment advantages when compared to oil-based polymers, *Ingeo*<sup>™</sup> also offers great properties relevant for product manufacturers, as for example (Resinex 2016b):

- Brightness, transparency and excellent translucency;
- Great flavour and aroma barrier;
- Good oxygen barrier;
- Easy to mold or give shape and print;
- Great moisture management properties (for applications such as clothing, textiles and non-woven fabrics);
- Hypoallergenic – it outperforms PET on breathing, comfort and low odour retention (for clothing, textiles and non-woven fabrics);
- High stiffness for low weight packaging;
- Low retraction.

Moreover, *NatureWorks*<sup>®</sup> created some series of *Ingeo*<sup>™</sup> for different processing, such as (NatureWorks LLC 2016j):

- *Ingeo*<sup>™</sup> 2000 series: extrusion/thermoforming;
- *Ingeo*<sup>™</sup> 3000 series: injection molding;
- *Ingeo*<sup>™</sup> 4000 series: films and sheets;
- *Ingeo*<sup>™</sup> 6000 series: fibres and non-woven textiles;
- *Ingeo*<sup>™</sup> 7000 series: blow molding;
- *Ingeo*<sup>™</sup> 8000 series: foam.

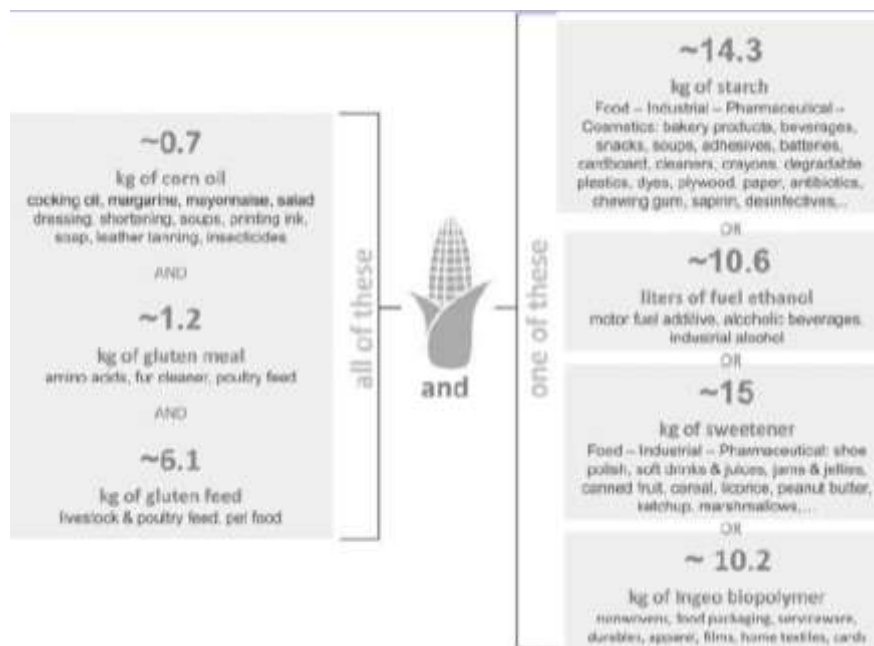
### 2.3.1.1.1.1. *Ingeo*<sup>TM</sup> Manufacturing Process

*NatureWorks*<sup>®</sup> presents in their own website the manufacturing process of *Ingeo*<sup>TM</sup>, as presented below.

1 – *Ingeo*<sup>TM</sup> bio-polymer starts with plants:

*Ingeo*<sup>TM</sup> is made from dextrose (sugar) that is derived from field corn – it is the most economically feasible source of plant starches – already grown for many industrial & functional end-uses (*NatureWorks* LLC 2016h). However, their process does not require corn but a sugar source, including in the future cellulosic raw materials, agricultural wastes and non-food plants (*NatureWorks* LLC 2016h).

To obtain *Ingeo*<sup>TM</sup>, *NatureWorks*<sup>®</sup> uses *Yellow Dent* #2 industrial corn (Vink and Davies 2015). The production of corn is primarily about food, feed and materials, and considering that the production of 1kg of *Ingeo*<sup>TM</sup> uses the starch fraction of 2,67kg corn (15% moisture), or the starch from 400.500 tonnes of corn if running the *Ingeo*<sup>TM</sup> production plant at full capacity, only represents the starch from 0,11% of total 2014 US corn production, which was 361 million tonnes, and 0,04% of world corn production, which was 988 million tonnes in 2014 (Vink and Davies 2015). Regarding this, corn oil, gluten feed, and gluten meal markets for that 0,04% would remain unaffected and available for other products, so there's little to no impact on food prices or supply (*NatureWorks* LLC 2016h). Below, Figure 8 shows the products that can be made from a bushel of *Yellow Dent* corn (25,4 kg).



**Figure 8:** Illustration of the products that can be made from a bushel of *Yellow Dent* #2 (Vink and Davies 2015).

Since the enterprise only uses the starch fraction – 57,2% (15% moisture) of the corn – for *Ingeo*<sup>TM</sup> production, the net corn use is (Vink and Davies 2015):

$$2,67 * 0,572 = 1,572 \text{ kg starch fraction of the corn (15\% moisture) / kg INGEO}^{\text{TM}}$$

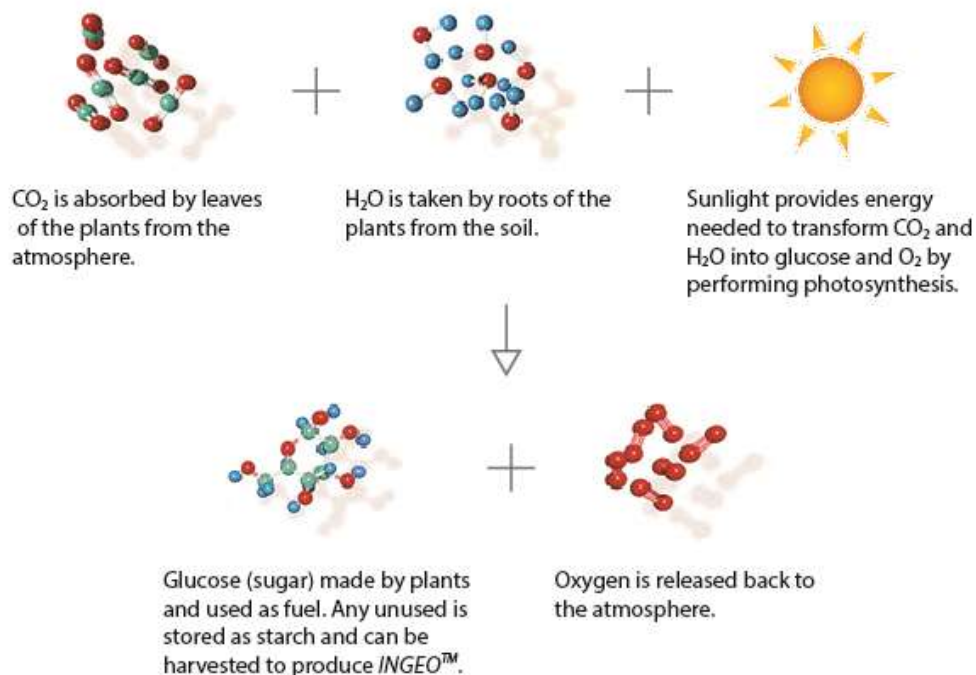
Using an average corn yield over the last 10 years for Nebraska and Iowa of 163bu/acre, equivalent to 1,023kg corn (15% moisture)/m<sup>2</sup> (1bu = 25,4kg and 1acre = 4046,86m<sup>2</sup>), which means that to produce 1kg of *Ingeo*<sup>TM</sup> is necessary (Vink and Davies 2015):

$$1,572/1,023 = 1,537 \text{ m}^2$$

Running the *Ingeo*<sup>TM</sup> production plant at full capacity – 150.000 tonnes – would mean a net land use of 23,055 hectares (Vink and Davies 2015). According to Carus and European Bioplastics, the available global agricultural area is about 5 billion hectares, which means that at full production *NatureWorks*<sup>®</sup> would only need 0,00046% of this land (Vink and Davies 2015). Considering that the production of plastic worldwide is 300 million tonnes, and assuming their replacement by bio-based polymers with the same land use per kg as PLA, only 0,9% of the 5 billion hectares of agricultural land available would be required to produce 300 million tonnes of plastic (Vink and Davies 2015).

## 2 – Photosynthesis – nature’s way of making sugar:

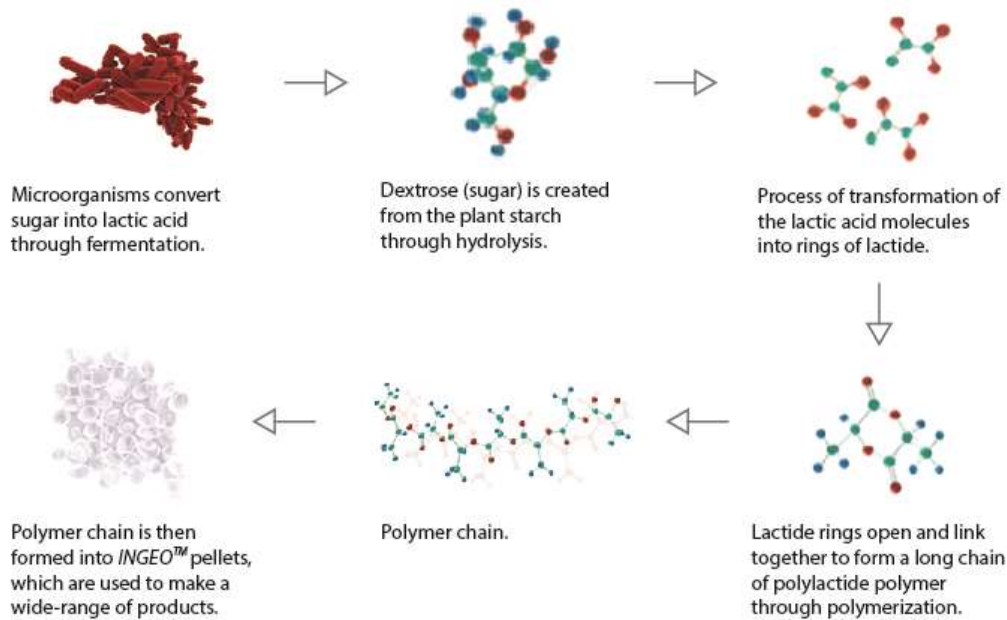
To produce bio-polymers, the carbon harnessed during photosynthesis must be used, which depending on the application, will be released back into the atmosphere within a period of 1 to 10 years, allowing plants to harness this CO<sub>2</sub> once again, closing the material carbon loop (Vink and Davies 2015). This means that *Ingeo*<sup>TM</sup>, and other bio-based materials, have intrinsic zero material carbon footprint, assuming that after use the carbon that remains in the polymer flows back into the atmosphere by composting or incineration (Vink and Davies 2015). It is important to mention that this closed carbon loop isn’t considering all the production process, where other fuel sources are used, for example, in transportation, transformation processes, light, etc. Even so, the carbon footprint for *Ingeo*<sup>TM</sup> is 75% lower than traditional materials like PS or PET (NatureWorks LLC 2016h). By scheme (Figure 9), the process of the plants to make sugar is:



**Figure 9:** Process of how plants make sugar (adapted from NatureWorks LLC 2016h).

After harvest, the corn is transported to the corn wet mill, where it is split into its components (proteins, fats, fibres, starch, ash, and water), and part of the starch is hydrolysed to dextrose using enzymes, which it is transported by pipeline to a lactic acid fermentation process (Vink and Davies 2015).

### 3 – Transforming sugar into polymer:



**Figure 10:** Process of how *NatureWorks®* to obtain *Ingeo™* pellets (adapted from NatureWorks LLC 2016h).

According to the scheme in Figure 10, *NatureWorks®* partners are already using *Ingeo™* for many products, as for example, food service ware, food packaging, bottles, folded cartons, non-wovens, paper coatings, films, clothing, home textiles, durable goods, cards, disposable materials, 3D printing wire and base matrix for composite materials (Resinex 2016b; NatureWorks LLC 2016h, 2016l).

#### 2.3.1.1.1.2. *Ingeo™* End-of-life Options

*NatureWorks®* states that their product “has more end-of-life options than any traditional plastic” and “products made with *Ingeo™* are compatible with existing recycling systems, can be cleanly incinerated, and are completely stable in landfill” (NatureWorks LLC 2016h). Despite having different end-of-life options (Figure 11), it is their intention that, in a long term, to keep to a journey to zero-waste by recycling the polymer into continuous applications and avoiding the other options while the polymer can keep its properties (NatureWorks LLC 2016d).



**Figure 11:** *Ingeo™* end-of-life options (NatureWorks LLC 2016h).

Due to being complicated to understand and know all the end-of-life cycle scenarios for all materials, especially for plastics, *NatureWorks*<sup>®</sup> developed efforts to understand them and on how to accomplish their end-of-life vision for *Ingeo*<sup>™</sup> – zero-waste. Regarding this, they created an animated end-of-life road map (Figure 12) to help everyone understand the current processes from collection of discarded items to end-of-life options (NatureWorks LLC 2016d).

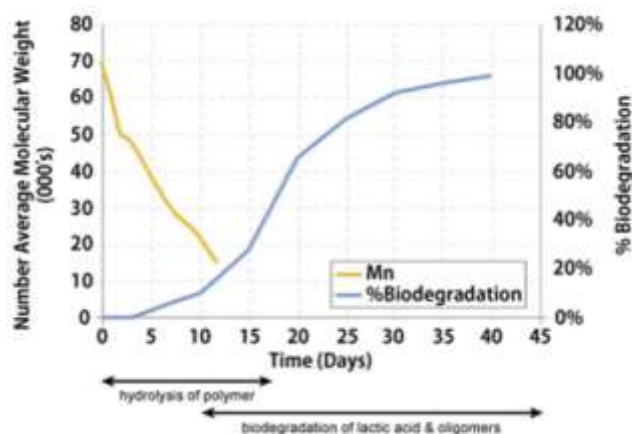


**Figure 12:** End-of-life road map (NatureWorks LLC 2016d).

Considering *NatureWorks*<sup>®</sup> end-of-life options, there is:

1 – Feedstock recycling: Since 2004, *NatureWorks*<sup>®</sup> has recycled more than 7,5 million tonnes of off-grade *Ingeo*<sup>™</sup> natural plastic at its Blair, Nebraska, processing facility by applying chemical hydrolysis, which transforms the PLA back into lactic acid for processing into essentially new PLA resin (NatureWorks LLC 2016d, 2016f).

2 – Composting: End-of-life products made with 100% *Ingeo*<sup>™</sup> will compost in municipal/industrial facilities according to ISO, ASTM and EN regulations, and in which *Ingeo*<sup>™</sup> is certified (NatureWorks LLC 2016b). This PLA undergoes in a two-step degradation process, as shown on Figure 13: first, the moisture and heat in the compost pile split the polymer chains into smaller polymers till lactic acid; second, microorganisms present in the compost and soil will consume lactic acid as nutrients, since they can metabolize lactic acid into carbon dioxide, water and humus (NatureWorks LLC 2016b).



**Figure 13:** Timetable for *Ingeo*<sup>™</sup> composting process (NatureWorks LLC 2016b).

3 – Incineration: In certain countries, waste-to-energy (WTE) facilities are used to burn wastes including municipal solid waste, refuse derived fuel and industrial waste (NatureWorks LLC 2016i). To understand the energy value of *Ingeo™* in WTE facilities, *NatureWorks®* conducted testing at the optimum incineration temperature of 1000°C and other analysis to check for any volatiles and/or residues during combustion (NatureWorks LLC 2016i). The results showed that *Ingeo™*'s heat content was determined to be 8368BTU/lb – equivalent to 19463,97kJ/kg – and suitable for incineration (Table 7), showed no volatiles and low residues when burning this polymer (Table 8) (NatureWorks LLC 2016i).

Comparing Energy Values	
Material	BTU/lb
Fuel Oil	20,900
HDPE	18,700
Rubber & Leather	12,800
PET	10,900
Wyoming Coal	9,600
Textiles	9,400
<b>INGEO</b>	<b>8,368</b>
Newspaper	8,000
Wood	7,300
Corrugated Boxes (paper)	7,000
Average MSW	5,900
Yard Waste	2,900
Food Waste	2,900

**Table 7:** Comparing of energy values of some materials (NatureWorks LLC 2016i).

Elemental Analysis		Decomposition Products	
Element	% Avg.	Compounds	mg/g
Carbon	50.05	Carbon Monoxide	ND (<0.1)
Hydrogren	5.71	Carbon Dioxide	2020
Oxygen	45.07	Water	>260
Nitrogen	0.04	Volatiles	ND (<0.001)
Sulfur	0.30	Semivolatiles	ND (<0.01)
Phosphorus	ND (<0.10)	Residue	0.01
Chlorine	ND (<0.05)		

**Table 8:** Results of the elemental analysis and decomposition products when burning *Ingeo™* (NatureWorks LLC 2016i).

4 – Landfill: Unfortunately, “*Ingeo™* does not biodegrade in a conventional landfill, neither does anything else. A landfill does not offer the necessary environment to compost so it is unlikely that any product will decompose efficiently” (NatureWorks LLC 2016k). Nevertheless, *Ingeo™* based products are better than oil-based plastic products because they contribute with less GHG and used less non-renewable energy (NatureWorks LLC 2016k). Moreover, *NatureWorks®*’ PLA is stable in landfills with no statistically significant quantity of methane released as shown by the results of ASTM D5526 and D5511 tests (NatureWorks LLC 2016k).

5 – Recycling (recovery and sortation): There are numerous plastics – oil-based and bio-based – that can be recovered and recycled, but when talking about oil-based plastics, which still have the most significant part of the market share, almost only PET and HDPE from bottles are being recycled (NatureWorks LLC 2016m). This is probably due to the underlying economics of recycling being often not attractive so plastic manufacturers prefer to produce new plastic from new raw materials than to recycle (NatureWorks LLC 2016m). Considering this, *Ingeo™* offers different recycling opportunities as it can be simply and economically recycled (NatureWorks LLC 2016m). While a bottle made of this PLA can be remade into a new bottle again and again, oil-based plastics are downcycled into products of diminishing value until their very last destiny in a landfill (NatureWorks LLC 2016m).

### 2.3.1.2. Life Cycle Assessment

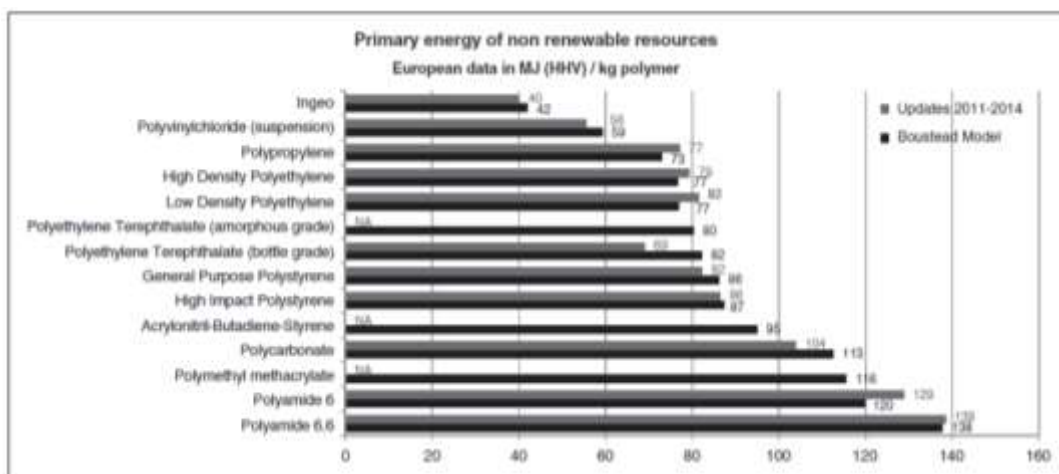
Life Cycle Assessment (LCA) is a system analysis tool which can be used to assess all the environment impacts of a product throughout its life, starting from the extraction of raw materials to the moment when a product in end-of-life returns to the Earth (Yates and Barlow 2013; NatureWorks LLC 2016g). The LCA involves collecting information on the inputs and outputs, such as air and water emissions, total raw material and energy used, as well as the total solid waste generated, from cradle-to-grave. This is known as Life Cycle Inventory (LCI) (NatureWorks LLC 2016g). Finally, a LCA translates the LCI data to a series of impact categories, as for example, contribution to climate change, smog creation, acidification, and human and ecosystem toxicity, followed by the assessment of the relevancy of the impacts in the environment (Yates and Barlow 2013; NatureWorks LLC 2016g).

*PlasticsEurope* has LCI data on oil-based plastics based on European averages, which can be used in studies for comparison with bio-based plastics (Yates and Barlow 2013). LCAs on bio-polymers derived from agricultural products include: fuel required for farming activities such as ploughing, agrochemical application, and harvesting; manufacture and transport of the materials required such as fertilizers, herbicides, and pesticides; land use and water consumption; nitrogen based emissions from fertilizer use and processes such as milling and production (Yates and Barlow 2013). There are many LCA available in the literature making comparison between bio-based and oil-based polymers, but the results can be very disparate (Yates and Barlow 2013), due to the many and different data available for assessment, thus providing completely different results for similar studies. However, as far as this is concerned, the results show that, although bio-based polymers have less negative environmental impact than oil-based ones, scientists and engineers still should go deeper on research in order to find better solutions for plastic when it reaches end-of-life and enters back into the natural environment.

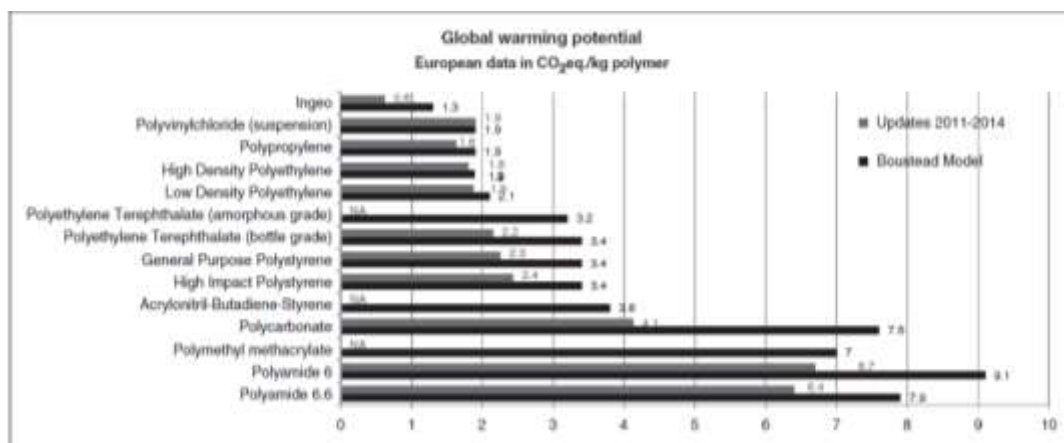
### 2.3.1.2.1. PLA – NatureWorks® Ingeo™ Life Cycle Assessment

NatureWorks® has already published eco-profile data for Ingeo™ production. An eco-profile is similar to a LCI but, while LCI takes into consideration the data from cradle-to-grave, an eco-profile only considers the data from cradle-to-factory gate (NatureWorks LLC 2016g). So, an eco-profile on Ingeo™, considers all the inputs and outputs of the manufacturing process from the growth of the plants to the boxes of Ingeo™ pellets leaving their factory (NatureWorks LLC 2016c).

Since the beginning of the 1990s, all eco-profiles published by *PlasticsEurope* were calculated by Boustead Consulting, yet since 2011, all the eco-profiles are updated using different LCA consultants (Vink and Davies 2015). This means that NatureWorks® has been using the same data and methodology as *PlasticsEurope* to make direct comparisons between their product and oil-based polymers (Vink and Davies 2015), which have presented better results for non-renewable energy use (NREU) and global warming potential (GWP) – also known as GHG, as can be seen in Figures Figure 14 and Figure 15.



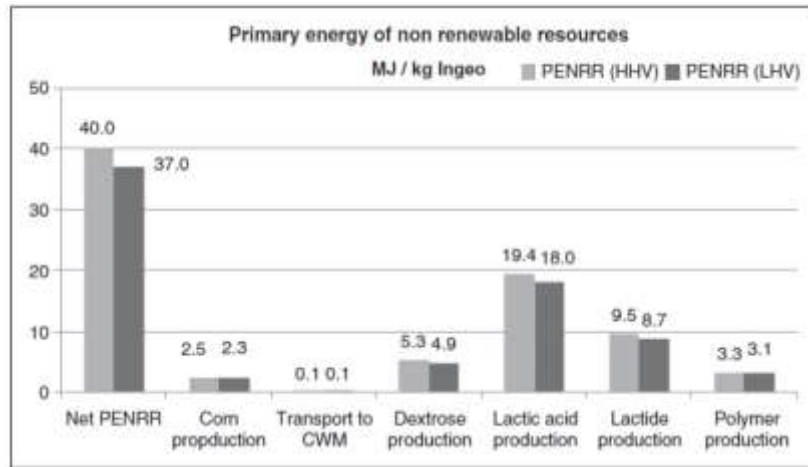
**Figure 14:** Comparison of the European data of the primary energy use of non-renewable resources for polymers production (Vink and Davies 2015).



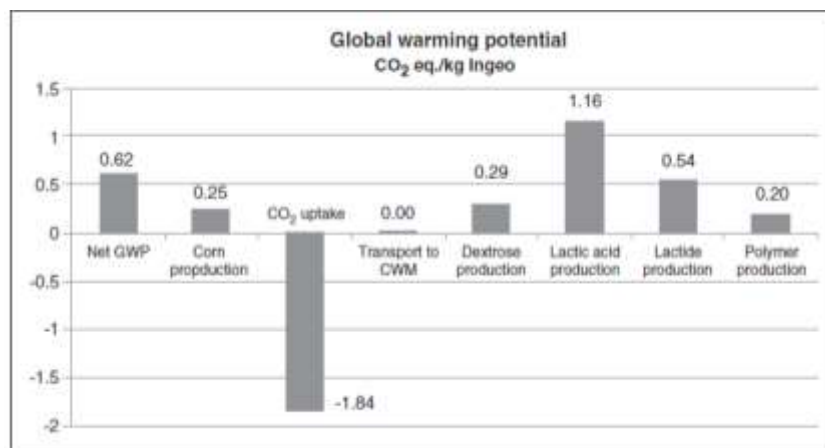
**Figure 15:** Comparison of the European data of the global warming potential or greenhouse gas emissions for polymers production (Vink and Davies 2015).



Considering the abovementioned but regarding the whole of *Ingeo™* production system and by individual process, the NREU and GWP results are shown in Figures Figure 16 and Figure 17.



**Figure 16:** Net NREU for the total *Ingeo™* production system and the NREU per individual process (Vink and Davies 2015).



**Figure 17:** Net GWP for the total *Ingeo™* production system and the GWP per individual process (Vink and Davies 2015).

It is important to mention that *NatureWorks®* have evolved their manufacturing process. In 2007, the eco-profile results for *Ingeo™* 2005 were 50,2MJ/kg *Ingeo™* and 2,02CO<sub>2</sub>eq./kg *Ingeo™*, respectively for NREU and GWP (NatureWorks LLC 2016c).

All facts considered, it is now understandable why the sustainability of bio-based plastics is questionable. To sum up, it has been proven that both situations, are neither sustainable nor environment friendly. Thus, *NatureWorks®* decided to provide information that proves that their product is sustainable and environment friendly, and shows to the world that it is possible to produce bio-based polymers with only a minimum negative impact on Earth, while other producers do not follow the same ideology. Bearing in mind the objectives of this dissertation, which is intended to use a bio-based biodegradable polymer to create a bio-composite, the *Ingeo™* meets the requirements for a polymer that should cause the less negative impact on Earth as possible.

## 2.3.2. Biodegradable Composite Materials with Polymeric Matrices

The need for polymers with high mechanical properties to meet the requirements of complex engineering led to the investigation of new composites. In sequence and as a result of the market growth of bio-based polymers, to the investigation of new bio-composites. As it happens with bio-based polymers, also bio-composites have many definitions and, among these, the most accepted was stated by Mohanty et al, which also corresponds to the definition stated in the CEN standard (Soroudi and Jakubowicz 2013). So, according to the definition, bio-composites are composite materials if at least one of the constituents is derived from natural resources (Soroudi and Jakubowicz 2013). However, many authors affirm that so as to be considered a bio-composite, all of its constituents must be derived from natural resources.

Bio-composites with a bio-based polymer matrix are called the future of *green composites* since it is possible to retain the whole carbon and use less oil resources (Soroudi and Jakubowicz 2013). To improve the properties of a bio-polymer, researchers usually blend bio-polymers in order to obtain the best properties of each polymer in the composite. In addition to blending different polymers, researchers also use additives to obtain specific properties for a desired objective.

Manufacturers have showed big interest in using polymeric composites in their products due to the low weight, reduced cost, unique and innumerable properties and to their processability, as is the case of polymers. With the increase of environment awareness, manufacturers are already using the *green composites* in some industries, as for example, automotive, construction, furniture and packaging (Soroudi and Jakubowicz 2013).

### 2.3.2.1. Additives for Polymers

As abovementioned, besides blending polymers to improve their properties, researchers also join different types of additives to polymers during compounding to impart desired properties without altering the molecular structure of the polymer (Subramanian 2013). Such additives include, for example, impact modifiers, fillers (particles or fibres), colorants, antioxidants, UV stabilizers, antistatic agents, anti-aging agents, fluorescent brighteners, melt strength enhancers, lubricants, cross-linking agents, heat stabilizers, viscosity stabilizers, foaming agents, antibacterial agents, etc. (Niaounakis 2013b). Overall, all the additives can be divided into the following groups: mechanical property modifiers, chemical property modifiers, processing property modifiers, aesthetic property modifiers, aesthetic property modifiers and others, such as, curing agents, clarifying agents, chain extenders, accelerators, slip or antislip agents, anti-plate-out additives and antiplasticizers (Subramanian 2013). It is important to mention that, considering bio-based polymers, the additives should be environment friendly so as not to compromise the efficiency of *green composites*.

Bearing in mind the defined objective for this dissertation, which is to present a product using almond nuts waste and *Ingeo<sup>TM</sup>* PLA, a literature review regarding mechanical

property modifiers had to be done. Based on the book *Plastics Additives and Testing*, written by Muralisrinivasan Subramanian, the mechanical property modifiers consist of fillers (particles and/or fibres), impact modifiers and nucleating agents (Subramanian 2013). This type of modifiers makes it possible to increase the strength and stiffness, improve the impact strength, improve light transmission, promote crystallinity and reduce the overall cost (Subramanian 2013).

Within the next few lines, the characteristics, advantages and disadvantages of using fillers, which are solid additives in a polymer to obtain a composite, will be presented bearing in mind that it is going to be used almost by-products in the form of small particles.

Thus, fillers used as reinforcement material for bio-composites include inorganic, vegetable and animal fibres and/or particles, as well as fillers derived from non-renewable resources (Niaounakis 2015a). It is interesting to know that initially, fillers were used as a way to increase the working time of polymers, and only more recently have been used as “functional fillers” (Subramanian 2013). In other words, nowadays they are used to reach a specific property on the material, as for example, to improve stiffness, toughness, etc.

The ideal blending composition can vary and will depend on the intended end use for the material to be blended. It is interesting to know that the effectiveness of composites depends largely on their ability to transfer the stress from the polymer matrix to the fillers, since the mechanical properties of composites reinforced by particles depend strongly on the dispersion state, interfacial adhesion, size, shape and particle content (Essabir et al. 2013). Regarding the shape of the particles, since the material is processed to small particles, they present irregular shape and size, like ground rock (Subramanian 2013).

But, besides being used to improve the performance of a composite, fillers also offer the opportunity to reduce the cost of the material, even more if we consider the natural fillers due to their abundance in nature and also due to the existence of waste in the agro-industries. For example, a quotation provided by *Amendouro* for a sack of 25kg of almond nuts waste was only of 2,60€ or 0,104€/kg – this value is subjected to the legal VAT. However, the incorporation of fillers may also affect the mechanical properties of a polymer unfavourably, as it will happen, for example, with the increasing of the percentage of the filler in the polymer, the composite will have its ductility capacity very low (Subramanian 2013). Therefore, composites will become stiff but brittle.

When it comes to natural fillers, such as almond by-products, these materials, besides being naturally degradable, are also hygroscopic and hydrophilic (Niaounakis 2015a). These characteristics are, in certain way, incompatible with hydrophobic polymers, such as PLA, so the blending of these two materials – PLA + natural filler – leads to poor interfacial adhesion and the formation of gases during processing, which, in turn leads to a product with lower mechanical properties due to the existence of porosity (Essabir et al. 2016). Considering this, the fillers should be dried before being blended with a hydrophobic polymer, to remove all the molecules of water and have a normal behaviour during processing.

Despite this drawback, because the drying step becomes mandatory, natural fillers are recommended to be used as additives for bio-polymers, enhancing their natural origin and biodegradability capacity (Subramanian 2013).

## 2.4. Products made from food waste

During the literature review, products made from food waste were also included in the search. In order to consider a product made from food waste, any product must be partly or fully made from agro-industry by-products and/or waste, food industry by-products and/or waste, domestic or industrial food waste and any other waste from edible products. In this context, the food waste as a product for combustion to produce energy or heat and its use for live feedstock is not being considered but products that allow the user to interact, have an experience and create emotional connections. Unfortunately, it was impossible to find a single product using waste from the almond industry. However, there are many different products using food waste, such as, for example, lamps, bowls, furniture, flower pots, etc. Some of them are presented below:

### A. Piñatex™

*Piñatex™*, created by Carmen Hijosa – CEO of *Ananas Anam*, which is based in London, England –, is a non-woven textile made from pineapple leaf fibres, which are a by-product from pineapple harvesting, and can be used as an alternative to existing textiles and leathers (Ananas Anam; Houston 2016). All the *Piñatex™* products (Figure 18) are composed of 80% of pineapple leaves fibres and 20% of PLA fibres (Ananas Anam). It is characterized as a strong, versatile, breathable, soft, light, flexible textile that can be easily printed on, stitched and cut (Ananas Anam). *Piñatex™* is already being used, both in products and prototypes, by some brands and designers in footwear, fashion accessories, furnishing and in the car and aeronautic industries, as it is possible to see in Figure 19 some examples (Ananas Anam).



**Figure 18:** Piñatex™ product range. From left to right: *Piñatex™* Original Charcoal, Natural and Brown; *Piñatex™* Oro Gold (Ananas Anam).



**Figure 19:** Example of some products using *Piñatex™* (Ananas Anam).

## B. *Mushroom*<sup>®</sup> Materials

*Ecovative*, founded by Eben Bayer and Gavin McIntyre, is a leading biomaterials enterprise based in Green Island, New York, USA, with high performance products that are safe, healthy and certified as sustainable (*Ecovative Design*). They created *Mushroom*<sup>®</sup> materials by using mycelium – also known as mushroom roots – that works as a natural and biological glue, agricultural waste, such as, for example, hemp and corn stalk, or wood fibres, and starch (*Ecovative Design*). By using the *Mushroom*<sup>®</sup> materials, *Ecovative* produces *MycoBoard*<sup>™</sup>, which is an engineered wood, *MycoFoam*<sup>™</sup>, that makes the replacement of the existing plastic foams, and *MycoMake*<sup>™</sup>, which is a *Grow It yourself* program created by themselves to allow people to create their own products (*Ecovative Design*). From *MycoBoard*<sup>™</sup> to furniture, architectural panels, door cores and cabinetry, and from *MycoFoam*<sup>™</sup> to packaging, acoustic and insulation tiles and, buoys and rafts, are some of the possible applications (*Ecovative Design*). Some of the products of brands and designers that are using *Ecovative*'s products can be seen at Figures Figure 20, Figure 21, Figure 22, Figure 23 and Figure 24.



**Figure 20:** *MycoBoard*<sup>™</sup> application: Enjoy Handplanes Mushroom Board Fish (*Ecovative Design*).



**Figure 21:** *MycoBoard*<sup>™</sup> application: *Gunlocke*<sup>®</sup> Savor guest seating (*Gunlocke*).



**Figure 22:** *MycoFoam™* application: *Mushroom® Packaging* components that provide cushioning and bracing in large packages for Dell servers (Ecovative Design).



**Figure 23:** *MycoFoam™* application: *Stanhope Seta* ships their products protected with *Mushroom® Packaging* (Ecovative Design).



**Figure 24:** *MycoMake™ GIY Mushroom®* material application: products made by the Designer Danielle Trofe (Morlin-Yron 2016).

### C. *Husque™*

Marc Harrison, product designer, and Paul Fairweather, architect and artist, are the founders and creators of *Husque™*, which is an innovative material using macadamia shells (Husque). “After the macadamia kernels are removed, the discarded shells are milled into fine particles, melded with a polymer, and the final product is formed into

beautiful and useful objects” (Husque). Their head office is located in Moorooka, Queensland, Australia. Below are presented some examples of products using this material (Figure 25).



**Figure 25:** Example of some products of the *Husque™* enterprise (Husque).

#### D. *Nuxite*

*Rust Brothers*, which is located at Minneapolis, Minnesota, USA, creates cabinetry and surfaces, following a “cradle-to-cradle philosophy of the natural ecological cycle, where waste from one process provides food for another”, since they “believe that beautiful things can be created without taking things from the earth that cannot be renewed or replaced” (Rust Brothers). So, they use waste of industrial and post-consumer glass and walnut shells waste from the walnut industries in their products. Thus, *Nuxite* is a sustainable surface made from grinded walnut shells, which is a renewable by-product of walnut crop harvests, suspended in a zero VOC (volatile organic compounds) resin binder (Rust Brothers). Some examples of the application of *Nuxite* are presented in Figure 26, below.



**Figure 26:** Example of an application for the *Nuxite* (Rust Brothers).

#### E. *OOObject*

*OOObject*, from Kwai Chung, Hong Kong, is one of the lines of *green & associates* which are one of the leading designers and manufacturers of high-quality and innovative products (Green & Associates). A team of experienced designers and engineers made *green & associates* become well-known in matching and applying different materials in their products (Green & Associates). Thus, *OOObject* is a line with “daily living objects” (Green & Associates). This line of products has a great diversity of objects using many and different recycled materials, such as, for example, ashes, ceramics, glass, cork, wax, agricultural waste and food waste, and, has as a base matrix for these materials, a biodegradable polymer. In Figures Figure 27, Figure 28 and Figure 29 there are examples of three products using apple dreg and pomace, coffee grounds, tea grounds and egg shells.





Figure 27: Yock yoyo (Green & Associates).



Figure 28: Nook toy car (Green & Associates).



Figure 29: Hloopy photo frame (Green & Associates).

## F. *Vipot*<sup>TM</sup>

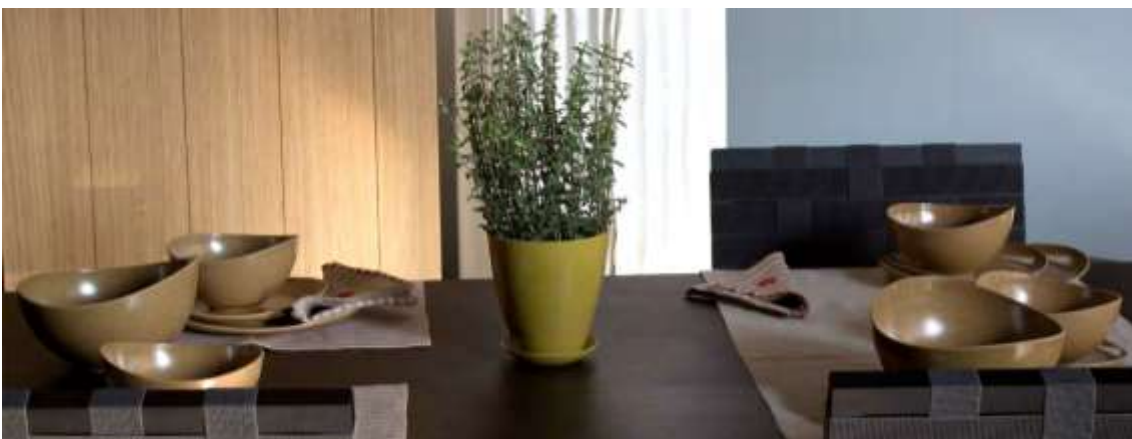
*Vipot*<sup>TM</sup>, which belongs to the group *Future Power*, is an innovative material made from rice husks, a by-product of the rice industry, and natural binders (*Future Power*). This material is being used in the production of decorative and “professional” flower pots and tableware (*Future Power*). The head office of *Vipot*<sup>TM</sup> is based in Treviglio, Bergamo, Italy. The products are presented in Figures Figure 30, Figure 31 and Figure 32 that follow.



**Figure 30:** Decor flower pot (*Future Power*).



**Figure 31:** Tecnici flower pot (*Future Power*).



**Figure 32:** Good 4 Food tableware (*Future Power*).

### G. *Foodscapes* Project

*Foodscapes* is a project of *Whomade*. *Whomade*, based in Milan, Italy, is founded as creative lab by Edoardo Perri, a designer, and Dario Riva, an art-director (*Whomade*). This enterprise is a network of creative professionals, working in the design and communication area, providing many services for supporting and improving the handicraft sector and the manufacturing traditional heritage (*Whomade*). Regarding the project, *Foodscapes* are food containers in the form of a shell using food waste such as peanuts shells and carrot husks, and potato starch as adhesive (*Whomade*; MATREC SRL 2015). This product is compostable and can be dissolved in water and used as soil fertilizer (*Whomade*). Figure 33 shows the product.



**Figure 33:** *Foodscapes* food containers (*Whomade*).

### H. *Biotrem*

*Biotrem* is located in Warsaw, Poland, and they make products using wheat husks or bran, which is a by-product from the production of wheat (*Biotrem* 2017). Jerzy Wysocki developed the manufacturing technology to produce 100% biodegradable tableware and cutlery (*Biotrem* 2017). All the tableware products are made only with wheat bran, while the cutlery uses PLA reinforced with 10% of wheat bran (Figure 34) (*Biotrem* 2017).



**Figure 34:** Some of the *Biotrem*'s products made from wheat bran and PLA (*Biotrem* 2017).

Bearing in mind all the presented products but not limited to, it is possible to realize that food waste may have increased value and an extended life cycle by being used as an important and natural resource to create products that can be very interesting and appealing for the consumer, as well as, environment friendly.



### 3. Case Study



This chapter will deal with the presentation of the case study carried through in order to achieve the objectives of this dissertation. Some literature review related with the subject of the case study will be quoted, in order to back up some of the conclusions. At the same time, these references will also back up the need to skip some of the important experiments that were totally impossible to perform due to the inexistence of some of the equipment or its high cost.

Bearing this in mind, in the first place all experimental work around the creation of the bio-composite to assess the behaviour of the materials – PLA + almond by-products – when being mixed, how easy is to give shape to the mouldable material and their aesthetics and texture will be presented. Thus, all the equipment, tools and materials that were used as well as the way how the experiments were performed and the results and conclusions achieved

Followingly, there is the presentation of the design proposal. Taking this into consideration, the problem definition, benchmarking, ergonomic study, product development, prototyping and product validation will be presented.

Finally, some renders of the final products are shown.

## 3.1. Bio-composite preparation

All the work implied in the preparation of the bio-composite will be presented along this chapter. The experimental work around the creation of the bio-composite using PLA and almond by-products is important to assess their behaviour when being mixed, how easy is to give shape to the mouldable material and their aesthetics and texture. According to some papers of the literature review such as, for example, the paper of Essabir et al. (2016) and Fernandes et al. (2015), which are about blending a polymer with the addition of a reinforcement, it was possible to perceive how to proceed in order to blend the bio-composite. However, the necessary equipment for this operation was not available so it was necessary to look for a different solution to blend the PLA with the almond by-products. The process of all experimental work and its results were also presented. Some additional experimental work such as the determination of the density of the almond by-products and microscopy visualisation of two different 3D printing wires were also included.

### 3.1.1. Blending experimental work

According to the information collected along the literature review, the way to prepare and/or produce a bio-composite will be explained further in the chapter at 3.1.3. However, as the necessary equipment to successfully obtain and test the bio-composite was not available for this particular research, the decision was to use some rudimentary techniques and other basic equipment and tools to evaluate the best way to blend the materials and assess the results. Thus, with the acquisition of some tools and with some of the available equipment in the facilities of the Faculty of Engineering of the University of Porto (FEUP), the materials were blended in four different ways to evaluate which one could be the best:

- Melting the PLA in a frying pan and mixing the materials with the help of hand scrapers to create plates;
- Melting the PLA in a frying pan and mixing the materials with the help of hand scrapers and then placing the melted material in a silicone mould to obtain a shape of a coffee cup by hand pressure;
- Grinding created plates to obtain small particles of the material and placing them in the vertical injection machine to be injected to a mould;
- Placing the neat PLA and milled almond by-products in the injection machine to be injected to a mould.

Before starting the blending experimentation with the *Ingeo™* PLA and the almond by-products, a work plan, where the raw materials, tools, equipment and raw materials preparation necessary to perform the experiments were considered, was thoroughly designed. Note that all the literature review regarding this part of the study, such as information about polymers suppliers, almond nut producers, examples of other scientific experiments, how to perform the experiments and expected results had already been studied. The experimental work was held in the FEUP, in the laboratories of the Department of Mechanical Engineering (DEMec), such as the Materialography



Laboratory (ML), Heat Treatment Laboratory (HTL) and the Design Studio (DS), in the Laboratory of the Department of Metallurgical and Materials Engineering (DEMM), as well as at INEGI – Institute of Science and Innovation in Mechanical and Industrial Engineering. This plan is divided in five stages, where the first three correspond to the acquisition of the materials, tools and equipment, the fourth stage is about the preparation of the materials and the fifth about the experimental work. The plan will provide a better organization during this phase of the dissertation, which is presented below (Table 9).






Blending Experimental Work Plan			
Step			
1 – Material acquisition:	What?	How?	Who / Where?
	PLA	Polymer suppliers	<i>Resinex</i>
	Almond by-products	Almond nut producers	<i>Amendouro</i>
2 – Tools acquisition:	What?	How?	Who / Where?
	Frying pan	Buy	Store
	Baking tray	Buy	Store
	Gloves	Buy	Store
	Hand scrapers	Buy	Store
	Plastic cups	Buy	Store
	Spoons	Buy	Store
	Scissors	Buy	Store
	Knife	Buy	Store
	Aluminium film	Buy	Store
	Towels	Buy	Store
	Kitchen roll	Buy	Store
	Plastic zip bags	Buy	Store
	Silicone release agent spray	Already acquired	FEUP - INEGI
	Aluminium cupcake moulds	Buy	Store
	Silicone mould	Already acquired	FEUP - ML
	Injection mould	Already acquired	FEUP - ML
3 – Equipment acquisition:			
	Grinder	Already acquired	FEUP – Laboratory of the DEMM

	Vibratory disc miller	Already acquired	FEUP – Laboratory of the DEMM
	Vibratory sieve shaker	Already acquired	FEUP – INEGI
	Precision weighing balance	Already acquired	FEUP – ML
	Hot plate	Already acquired	FEUP – HTL
	Heat treatment furnace	Already acquired	FEUP – HTL
	Vertical injection machine	Already acquired	FEUP – ML
4 – Material preparation:			
	Almond hulls, shells and skins	a. Dry	FEUP – HTL
		b. Grind	FEUP – Laboratory of the DEMM
		c. Mill	FEUP – Laboratory of the DEMM
		d. Particle-size distribution	FEUP – INEGI
		e. Sort by size in plastic zip bags	FEUP – INEGI
		f. Dry	FEUP – HTL
	PLA	g. Grind	FEUP – Laboratory of the DEMM
5 – Blending experimental work:	Experiment	Description	
	BE1	Melt the PLA in a frying pan and mix the materials with the help of hand scrapers to create plates	
	BE2	Melt the PLA in a frying pan and mix the materials with the help of hand scrapers and place the melted material in a silicone mould to obtain a coffee cup by hand pressure	
	BE3	Grind created plates to obtain small particles of the material and place in the injection machine to injected into a mould	
	BE4	Place the neat PLA and milled almond by-products in the injection machine to be injected into a mould	


**Table 9:** Blending experimental work plan to assess the best way to blend the materials.







### 3.1.1.1. Materials, tools and equipment

Following there is the presentation of both materials, PLA and almond by-products as well as some of the most important tools and all the equipment mentioned in the blending experimental work plan (Table 9). As far as the equipment is concerned, only a small description of each equipment's main function will be considered. The brand and model used as well as the main characteristics will also be specified. As for tools, merely their function for the experimental work will be referred. So, bellow there is a series of illustrating tables with the materials, tools and equipment used (Table 10, Table 11 and Table 12)


Material	Description	Aspect	
Matrix – PLA 	<i>NatureWorks® Ingeo™ 3251D</i> , which is designed for injection molding process with a melting mass-flow rate of 35g/10min at 190°C and 80g/10min at 210°C (ASTM D1238), a density of 1.24g/cm <sup>3</sup> (ASTM D792) and a clear/transparent aspect (Appendix I). Moreover, its processing temperature avoids the degradation of the almond by-products.	Grinded 	
Reinforcement – Almond by-products 	Hulls, shells and skins provided by <i>Amendouro</i> , with a density of 1.281 g/cm <sup>3</sup> .	Grinded 	Milled 






**Table 10:** Materials used during blending experimental work.


Tools	Experimental function
Frying pan 	Used to melt the PLA and make the mixture while being heated by the hot plate.
Aluminium baking trays	Used to dry the almond by-products and to place the melted material to

	create plates after being hand pressured.
Hand scrapers 	Used to mix the materials on the frying pan.
Silicone release agent spray 	Used to spray the aluminium baking tray and the aluminium cupcake moulds before placing the melted material and, the injection mould before starting the injection.
Aluminium cupcake moulds 	Used to place the melted material and give shape to it after being hand pressed.
Silicone mould 	Used to place the melted material and give shape to it after being hand pressed.
Injection mould 	Used to test the material by injection.

**Table 11:** Some tools used during the blending experimental work.

Equipment	Description	Equipment used
Grinder 	Used to grind soft, medium-hard, elastic and fibrous materials. Their final fineness can vary from $\approx 0,25\text{mm}$ to $20\text{mm}$ . The maximum recommend feed size is, usually, smaller or equal to $60 \times 80\text{mm}$ .	(Unknown model)

<p>Vibratory disc miller</p> 	<p>Used to mill medium to hard, brittle and fibrous materials by impact and friction. Usually, the acceptable feed size materials are <math>\leq 20\text{mm}</math> and their final fineness may vary from <math>\approx 20\mu\text{m}</math> to <math>100\mu\text{m}</math>.</p>	<p>Retsch RS 1 Final fineness: <math>&lt;20\mu\text{m}</math> Material feed size: <math>&lt;15\text{mm}</math></p>
<p>Vibratory sieve shaker</p> 	<p>Used for the separation, fractioning and assessing the particle-size distribution of granular materials, such as powders and bulk materials.</p>	<p>Retsch AS 200 Control Measuring range: <math>0,20\mu\text{m}</math> to <math>25\text{mm}</math> Amplitude: <math>0,2\text{mm}</math> to <math>3\text{mm}</math></p>
<p>Precision weighing balance</p> 	<p>Used to measure the mass with maximum accuracy, from high loadings, such as <math>&lt;70\text{kg}</math>, to <math>0,0001\text{mg}</math>.</p>	<p>KERN PFB 6000-1 Max. weighing range: <math>6000\text{g}</math> Readability: <math>0,1\text{g}</math></p>
<p>Hot plate</p> 	<p>Used for safe and precision heating.</p>	<p>IKA® RCT Basic Temperature range: <math>0^{\circ}\text{C}</math> to <math>310^{\circ}\text{C}</math></p>
<p>Heat treatment furnace</p> 	<p>Used to temper, anneal, harden and quenching, forge, curing, preheat, dry, age, etc. a different range of materials.</p>	<p>Termolab Chamber Furnace (unknown model)</p>
<p>Vertical injection molding machine</p>		<p>(Unknown model)</p>

	<p>Used for producing plastic products by the injection molding process.</p>	
---	--	--

**Table 12:** Equipment used during blending experimental work.

### 3.1.1.2. Raw materials preparation

Before proceeding to the blending experimental process, it was necessary to prepare both raw materials, PLA and almond by-products. The almond by-products had to be reduced into small particles so that they could be used as a filler, while the PLA appeared to be more interesting to be obtained in a smaller particle-size for the experimentation, mainly to use in BE4 in the vertical injection machine since it may easily mix with the almond by-products. Thus, both processes are presented below:

- Almond by-products
  - a. Based on Niaounakis (2015a) who wrote that “a typical drying procedure of vegetable fibres and/or fillers is 24h, at 60°C in an oven with circulation of air”, and Essabir et al. (2016) that dried argan nut shells at 80°C in an oven under vacuum, it seemed sensible to decide to dry the almond by-products during 12h at 80°C in a heat treatment furnace in order to remove part of the moisture (Figure 35). This process will eliminate most of the moisture if the almond by-products have a percentage of moisture higher than the normal acceptable values.



**Figure 35:** Process of removing part of the moisture from the almond by-products by placing them in a furnace, for 12h at 80°C, in the Heat Treatment Laboratory.

- b. After being dried, the almond by-products were grinded in order to obtain small particles (Figure 36).



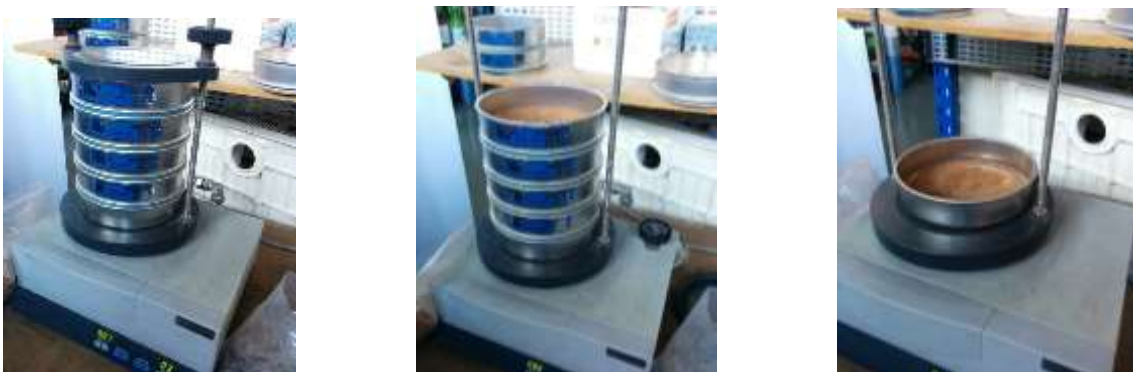
**Figure 36:** Process of grinding the almond by-products, that have been partially dried, in a grinder in the Laboratory of the DEMM.

- c. Part of the grinded particles were milled in a vibratory disc miller in order to obtain even smaller particles (Figure 37).



**Figure 37:** Process of milling the grinded almond by-products in a vibratory disc miller in the Laboratory of the DEMM.

- d. All the grinded and milled particles were placed in a vibratory sieve shaker equipped with a cascade of different mesh sieves with an amplitude of 0,90mm for 3 minutes to obtain the particle-size distribution. Thus, for the grinded particles, the mesh sieves: 630 $\mu$ m, 315 $\mu$ m, 125 $\mu$ m, 90 $\mu$ m were the selected ones; and for the milled particles the mesh sieves: 400 $\mu$ m, 315 $\mu$ m, 125 $\mu$ m, 90 $\mu$ m, 53 $\mu$ m (Figure 38).



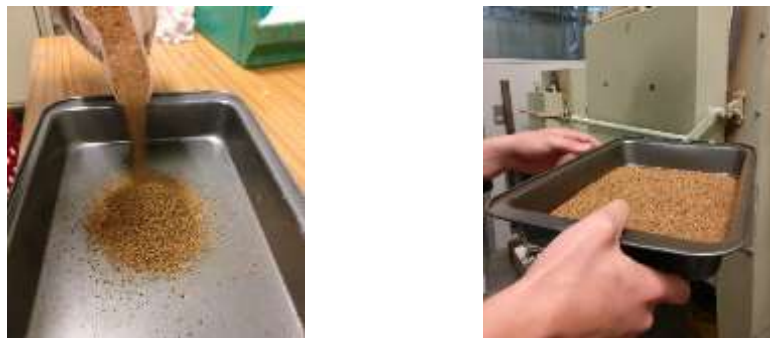
**Figure 38:** Process of sieving the grinded and milled almond by-products in a vibratory sieve shaker in INEGI.

- e. After being sieved, the particles were apportioned according to the particle-size and placed in plastic zip bags (Figure 39).



**Figure 39:** Process of separating the sieved particles into plastic zip bags by particle-size distribution in INEGI.

- f. In the end, the particles were placed in the heat treatment furnace again at 65°C for 6h, just before being used to blend with the PLA. This process becomes necessary since the almond by-products, immediately after being taken out of the oven, start absorbing the humidity from the air (Figure 40).



**Figure 40:** Second drying process of the almond by-products particles just before being blended with the PLA in the chamber furnace, for 6h at 65°C in the Heat Treatment Laboratory.

- PLA

- g. Some PLA pellets were grinded to obtain small particles of it. This may be interesting due to being easier to melt the material (Figure 41).



**Figure 41:** Process of grinding the PLA in a grinder in the Laboratory of the DEMM.



### 3.1.1.3. Blending experimental work

#### I. BE1: Creating a plate

- a. The option for this blending experimentation was to use 10% to 40% of reinforcement. Thus, before starting the melting and mixing process it was necessary to measure, for a total weight of 30g, the exact quantity of PLA and almond by-products particles. Besides, it was decided to use a particle-size between 90 $\mu$ m to 125 $\mu$ m in all the experiments, due to the internal diameter of the sprue bushing of the injection mould (Figure 42).



**Figure 42:** Measuring the weight of the PLA and almond by-product particles before being blended.

- b. The pellets of PLA were placed in the frying pan, which had been previously pre-heated. When the pellets started gaining some transparency, they were stirred until a paste-like mixture was obtained (Figure 43).



**Figure 43:** Melting the PLA pellets in a frying pan.

- c. After obtaining the paste-like mixture, the almond by-product particles were poured over the PLA and blended up to the point of getting a homogeneous material (Figure 44).



**Figure 44:** Blending the melted PLA with the almond by-products particles.

- d. Before placing the resulting material from the blend in the baking tray, it was sprayed with the release agent spray. Then, the material was placed in the baking tray and hand pressed with the help of another baking tray in order to obtain a plate of the material (Figure 45).







**Figure 45:** Creating a plate by hand pressure using two baking trays.

- e. As soon as the material gets to, approximately, the room temperature, the plate was removed from the baking tray (Figure 46).



**Figure 46:** Removing the plate with the new material.

More than creating plates, the main objective of this blending experimentation, was to check the feasibility of blending these two materials in a frying pan. Considering this, it was verified that blending particles with a size between  $90\mu\text{m}$  to  $125\mu\text{m}$  with the PLA results in a harder material with the increase of the reinforcement. The blending procedure should be slow to avoid spreading the particles, which are very small and low weight, and so, with the increase of the percentage of the reinforcement in the PLA, the particles start to get burned before the blending process is concluded. Using particles with a larger size should avoid this problem yet extra experiments using different particle-sizes will be done later. The plates can easily be made with this process. The results of blending experimentation 1 are shown below (Table 13).

Results of BE1			
			
Total weight: 30g	Total weight: 30g	Total weight: 30g	Total weight: 30g
Reinforcement: 10%	Reinforcement: 20%	Reinforcement: 30%	Reinforcement: 40%

**Table 13:** Final results of blending experimentation 1.

## II. BE2: Creating a coffee cup

- f. The same steps of BE1 from a to c were repeated (Figures Figure 42, Figure 43 and Figure 44). However, in this experiment, the reinforcement percentage had a variation from 5% to 20%. Moreover, due to the fact that the exact amount of material to fill the mould was still unknown, the amount of PLA had a weight variation from 20g to 35g.
- g. The resulting material from the blending procedure was then placed in the silicone mould and the negative silicone mould was placed on top. Then, hand pressure was applied on it. The material of the mould, avoided the use of the release agent spray (Figure 47).







**Figure 47:** Creating a coffee cup by hand pressure using a silicone mould.

- h. As soon as the material reached, approximately, room temperature, the coffee cup with the new material was removed from the silicone mould (Figure 48).



**Figure 48:** Removing the coffee cup with 5% of reinforcement from the silicone mould.

During this experiment, it was decided to start with a small amount of material to verify if it would fill the whole mould or not. The conclusion was that 20g of PLA was not enough to fill the mould and 30g barely filled the mould. So, for the two last experiments, the amount of PLA used was increased to 35g. All the experiments were successfully accomplished but, as mentioned in *BE1*, it is possible to verify that by increasing the percentage of the reinforcement, the coffee cups get darker as the fine particles started to burn. The results of blending experimentation 2 are shown below in Table 14.

Results of BE2			
			
PLA: 20g	PLA: 30g	PLA: 35g	PLA: 35g
Reinforcement: 5%	Reinforcement: 10%	Reinforcement: 15%	Reinforcement: 20%

**Table 14:** Final results of blending experimentation 2.

It is important to refer that all the coffee cups presented small defects in their base which could have been caused as a consequence of the presence of gases, such as, for example, from H<sub>2</sub>O vapour (Figure 49).



**Figure 49:** Defects in the base of the coffee cups.

### III. BE3: Injection moulding using grinded plates with the created bio-composite

- i. For this experiment, all the steps of *BE1* were repeated so as to create some plates with 20% of almond by-products particles and with a total weight of approximately 100g.
- j. After obtaining the plates, the grinder of the Laboratory of the DEMM was used to grind them. They had been broken into smaller pieces before being placed in the machine in order to obtain small particles that would easily get melted in the vertical injection machine (Figure 50).



**Figure 50:** Plates before and after being grinded.

- k. Before advancing to the injection procedure, some of the grinded material was placed in the cylinder, with a temperature set to 185°C, to eliminate any residues of other polymers from previous injections (Figure 51).



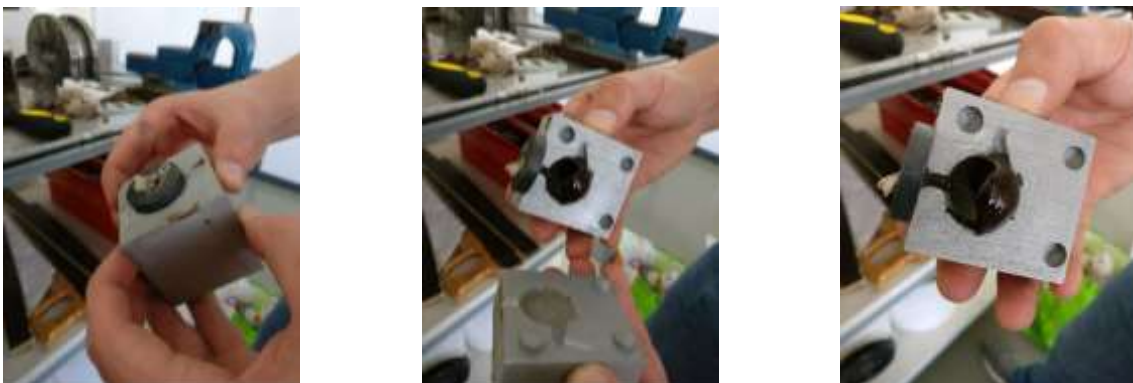
**Figure 51:** Placement of material in the cylinder to eliminate any residues of other polymers.

- l. With the stroke length of the machine cleaned of any other materials, more material was added and, the injection mould, which had previously been sprayed with the release agent, was placed in the correct position for injection (Figure 52).







**Figure 52:** Preparing the mould for an injection.

- m. In the end, after the injection of the material in the mould and after waiting, for approximately 15 to 20 minutes to allow the temperature to decrease, the mould was opened to remove the piece (Figure 53).



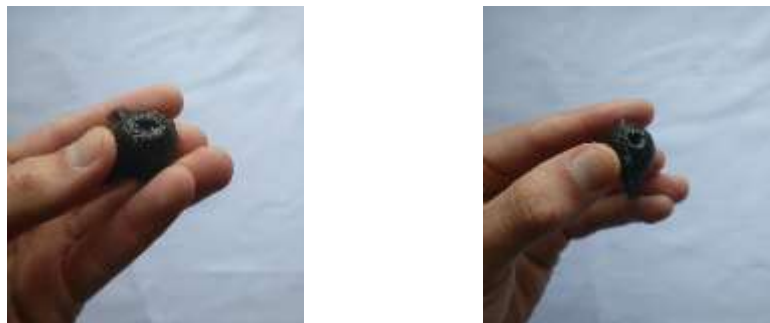
**Figure 53:** Opening the mould after the injection of the material.

This experiment allowed to understand that this material is suitable for injection moulding. However, it was very hard to obtain good results. Firstly, the injection machine used is obviously not the most appropriate to perform such experiments, due to its limited specifications. Secondly, the absence of a hopper dryer in the injection machine does not allow to keep the moisture of the material controlled. Lastly, it was very difficult to place the injection mould in the correct position before proceeding to the injection. So, instead of getting the material injected into the mould, it was all spread out of it. In conclusion, another injection machine should be used to perform these experiments and analyse the results. Below are shown the results of the blending experimentation 3 (Table 15).

Results of BE3			
			
Injection 1	Injection 2	Injection 3	Injection 4
Reinforcement: 20%	Reinforcement: 20%	Reinforcement: 20%	Reinforcement: 20%

**Table 15:** Final results of blending experimentation 3.

As it happened in the *BE2*, even the successful injections, *1* and *3*, have a defect each, which could have been caused by the presence of gases during the injection, as shown in Figure 54.



**Figure 54:** Defects in two injected pieces.

#### IV. BE4: Injection moulding using grinded PLA and almond by-products particles

- n. For this experimentation, step *a* was repeated. However, despite the slight change of using grinded PLA instead of PLA pellets, the percentage of almond by-products particles was the same of *BE3*, so, 20%.

- o. After measuring 50g of grinded PLA and 10g of almond by-products particles, they were mixed in a cup with the help of a spoon (Figure 55).



**Figure 55:** Mixing grinded PLA with the almond by-products particles.

- p. Although this experiment was carried out after BE3, the injection machine was also cleaned. So, step k was repeated (Figure 56).



**Figure 56:** Process of cleaning the cylinder of the injection machine.

- q. After this, steps l and m were also repeated.

The main objective of BE4 was to observe if the two materials were mixed in the moment of the injection and the results were positive. There were the same difficulties as in the previous experiment but the injected material had the same aesthetics as in BE1, BE2 and BE3. Note that if the material stays in the cylinder for a long period of time it starts to burn, so it gets darker.

In conclusion, from all the blending experimentation methods, the method of *BE2* provided the best results and the most appealing to evaluate.

### 3.1.2. Experimental work with different granulometries

Chapter 3.1.1 made it possible to understand the best way to blend the polymers considering the equipment and conditions available. Bearing this in mind, it was performed more experiments using different granulometries and percentages of reinforcement using the method of *BE2*. However, the experimental work described ahead was not done with a silicone mould since it was not available at the time. Thus, two aluminium cupcake moulds were then used to give shape to the melted material. This time, all the steps from *f* to *h* were once more repeated yet using a different mould for steps *g* and *h*, as shown in Figures Figure 57 and Figure 58.



**Figure 57:** Step g – Process of placing the melted material in the aluminium cupcake mould, which was previously sprayed with a release agent spray, and hand pressure with the help of a stick to avoid burning in the hands.



**Figure 58:** Step h – Process of removing the piece from the aluminium cupcake mould.

This experimental work will allow, in phase 1, to evaluate the possibility of blending the two materials with different percentages of the reinforcement, as well as its aesthetics, texture and mouldability. After getting to a conclusion of phase 1 experimental work, phase 2 experimental work will be carried out. This consists in picking the best results from phase 1 and use them to finally achieve the expected composite. Only after phase 2 is accomplished it will be possible to conclude which bio-composite created will be used to apply in the product.

### 3.1.2.1. Plan of work for the experimental work with different granulometries

Before proceeding to the experimental work with different granulometries and bearing in mind all the previous experimental work, a plan of the experiments to be done was thoroughly defined. This plan was divided in two phases: in phase 1 the PLA with specific granulometries with different percentages was blended; and, in phase 2 PLA with two different granulometries with a specific percentage was blended. Both will be defined after concluding phase 1. All the experimental work was performed in the Heat Treatment Laboratory. According to the plan, each granulometry will be blended in percentages of 10%, 20%, 30%, 40% and 50%, except for the finest granulometries since it was proved to be very hard to blend them without beginning to burn on the previous experimental work (Table 16). Note that, in phase 1, the almond by-products particles that were crushed (C) or milled (M) won't be mixed even if they have the same granulometry. Moreover, some experiments with 40% and 50% of some granulometries will not be performed due to the difficulties felt on the previous work.

































Experimental work with different granulometries: Phase 1					
Reinforcement Granulometry	10%	20%	30%	40%	50%
C: > 630µm	X	X	X	X	X
C: 315µm to 630µm	X	X	X	X	X
C: 125µm to 315µm	X	X	X		
M: > 400µm	X	X	X	X	X
M: 315µm to 400µm	X	X	X	X	X
M: 125µm to 315µm	X	X	X	X	
M: 90µm to 125µm	X	X	X		
Experimental work with different granulometries: Phase 2					
To be defined after analysing the results of phase 1					

**Table 16:** Plan of work for phase 1 experimental work.

### 3.1.2.2. Phase 1: Results and conclusion

Considering the results presented on Table 17, it was possible to conclude that by blending almond by-products particles, that have a particle-size above 125µm, with the PLA it is much easier and probable to obtain a successful piece than blending particles with a particle-size below 125µm, since they quickly start to get burned. It was also possible to conclude that by applying above 40% of reinforcement it would become very hard to give shape to the melted material due to the high content of particles. Regarding the aesthetics of the created pieces, it is possible to note that the smaller the particles, the more homogeneous the appearance of the pieces created. This can be easily verified in the images above showing the results for 10% of reinforcement. On the one hand, it is possible to notice that, mainly for 40% and 50% of reinforcement, the bigger the particles, the bigger the roughness of the piece and, on the other hand pieces using particles with a particle-size from 90µm to 125µm have a softer texture when touched.

In the end, it was considered that the best pieces were obtained with 20% to 30% of reinforcement depending on the granulometry. Below, Table 17, presents the results of the phase 1 experimental work.

		Reinforcement [%]				
		10	20	30	40	50
Granulometry [ $\mu\text{m}$ ]	>630					
	315 to 630					
	125 to 315					
	>400					
	315 to 400					
	125 to 315					
	90 to 125					

**Table 17:** Results of phase 1 experimental work.

### 3.1.2.3. Phase 2: Work plan, results and conclusion

As soon as phase 1 was concluded, it was time to proceed to phase 2, which is intended to create five more pieces using two different granulometries in each piece with reinforcement percentages from 20% to 30%.

Here the decision included the addition of a different material in two of the next experiments. Thus, due to the availability of Ethylene Vinyl Acetate (EVA) at FEUP,

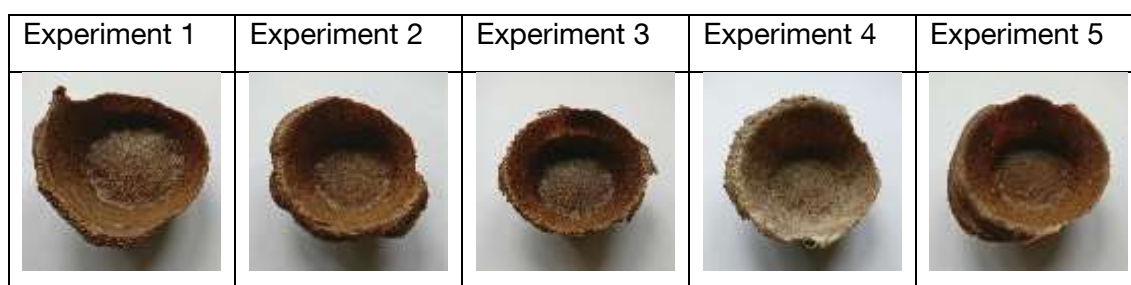
testing the behaviour of mixing a different and much more flexible polymer, seemed to be interesting. Despite EVA not being derived from natural resources and not being biodegradable, that does not mean it cannot be used in a bio-composite. However, the main purpose of these two experiments is to observe if the pieces created become more flexible due to the addition of the referred polymer and not to consider this composite with EVA to apply in the product to be developed.

Thus, it is presented below the work plan of phase 2 (Table 18).

Experimental work with different granulometries: Phase 2			
	Reinforcement percentage	Particle-size	EVA percentage
Experiment 1	30%	M: >400µm (23,3%) M: 125µm to 315µm (6,66%)	0%
Experiment 2	30%	C: >630µm (20%) M: 125µm to 315µm (10%)	0%
Experiment 3	25%	C: 315µm to 630µm (20%) M: 90µm to 125µm (5%)	0%
Experiment 4	30%	C: >630µm (25%) M: 125µm to 315µm (5%)	30%
Experiment 5	25%	C: >630µm (5%) M: 125µm to 315µm (20%)	15%

**Table 18:** Plan of work for phase 2 experimental work.

As abovementioned, the same blending process as in the experimental work of phase 1 was used here and the results of phase 2 experimental work are presented below (Table 19).



**Table 19:** Results of phase 2 experimental work.

This last experimental work allowed to understand that pieces using these materials may be created with a great variety of visual aspects since they can be blended with different granulometries and percentages. Besides this, it proved to be very similar to phase 1 experimental work. Regarding experiments 4 and 5, the addition of EVA changed the flexibility of the pieces just as predicted, mainly in experiment 4 due to a greater percentage of EVA when compared to experiment 5. However, the aesthetics of

the piece from experiment 4 is very poor when compared to that of the other experiments.

As a conclusion, the piece that was the result of experiment 2 was considered to be the most appealing in terms of aesthetics and texture in comparison with the other results.

### 3.1.3. Bio-composite production process

Regarding the experimental process abovementioned, it is important to refer that this is by no means the most adequate process for scientific analysis. However, when coming back to the main objective of the present dissertation, which is to develop a new product design to apply the bio-composite using a bio-based polymer (PLA) as matrix and almond by-products as reinforcement, accurate scientific research is not an ultimate requirement. Besides this, the indispensable equipment and conditions for a strict scientific research were not available during this research, which implied to adapt the experimental work to the equipment and conditions available. Thus, a production process is then suggested to obtain this bio-composite. This way, the characterization of the material could also be made.

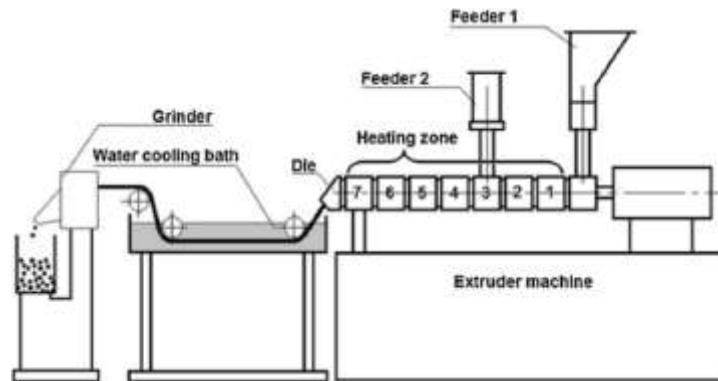
For the first step, and just as the conditions in the previous experimental work, the almond by-products must be dried till they lose most or all of the moisture. However, this drying process must be done in a proper equipment to ensure the intended moisture of 0% is achieved, as well as making this process in controlled environment conditions. Otherwise, as soon as the almond by-products leave the oven, they may recover part of the moisture through the humidity of the air around. Since it is very hard to keep a very low value of moisture in the almond by-products during all the following steps in the procedure, this first step is only justified if the acquired almond by-products contain a high level of moisture. Avoiding high levels of moisture will allow grinding and milling the hulls, shells and skins of the almond nuts more successfully.

Secondly, the dried almond by-products must be grinded and/or milled to obtain small particles.

Then, once being aware of the particle-size distribution through the use of a sieve shaker equipped with a cascaded of different mesh sieves comes the following step. This is important to guarantee that there are only particles within a specific range of size when being blended with the polymer.

Followingly this, the particles of almond by-products need to go back into the oven in order to remove any of the moisture that has been acquired during the grinding and milling process. This process should be made in controlled environment to guarantee the particles recover the least moisture possible as soon as they leave the oven. Moreover, as soon as the particles are removed from the oven, they should be placed in bags which, in turn should be immediately sealed in vacuum in order to avoid any risk of absorption of humidity. This process will avoid the creation of bubbles of air as a consequence of evaporation of water while the material is being injected at high temperatures.

The fifth and next step implies the blending of the almond by-products particles and the PLA pellets. This mixture should be made in a twin-screw extruder with two feeders (Figure 59). Besides this and following the example of other materials' researchers, the extrusion of the material should be followed of a water cooling bath and, in turn, by a pelletizing of the material.



**Figure 59:** Material blending in a twin-screw extruder (Essabir et al. 2016).

Finally, the process to obtain the bio-composite ends after drying the obtained pellets in an oven.

At this moment, the pellets are ready to be injected into the moulds. For a scientific research, the specimens for the characterization of the material can now be created and tested/analysed according to standards.

### 3.1.4. Additional experimental work

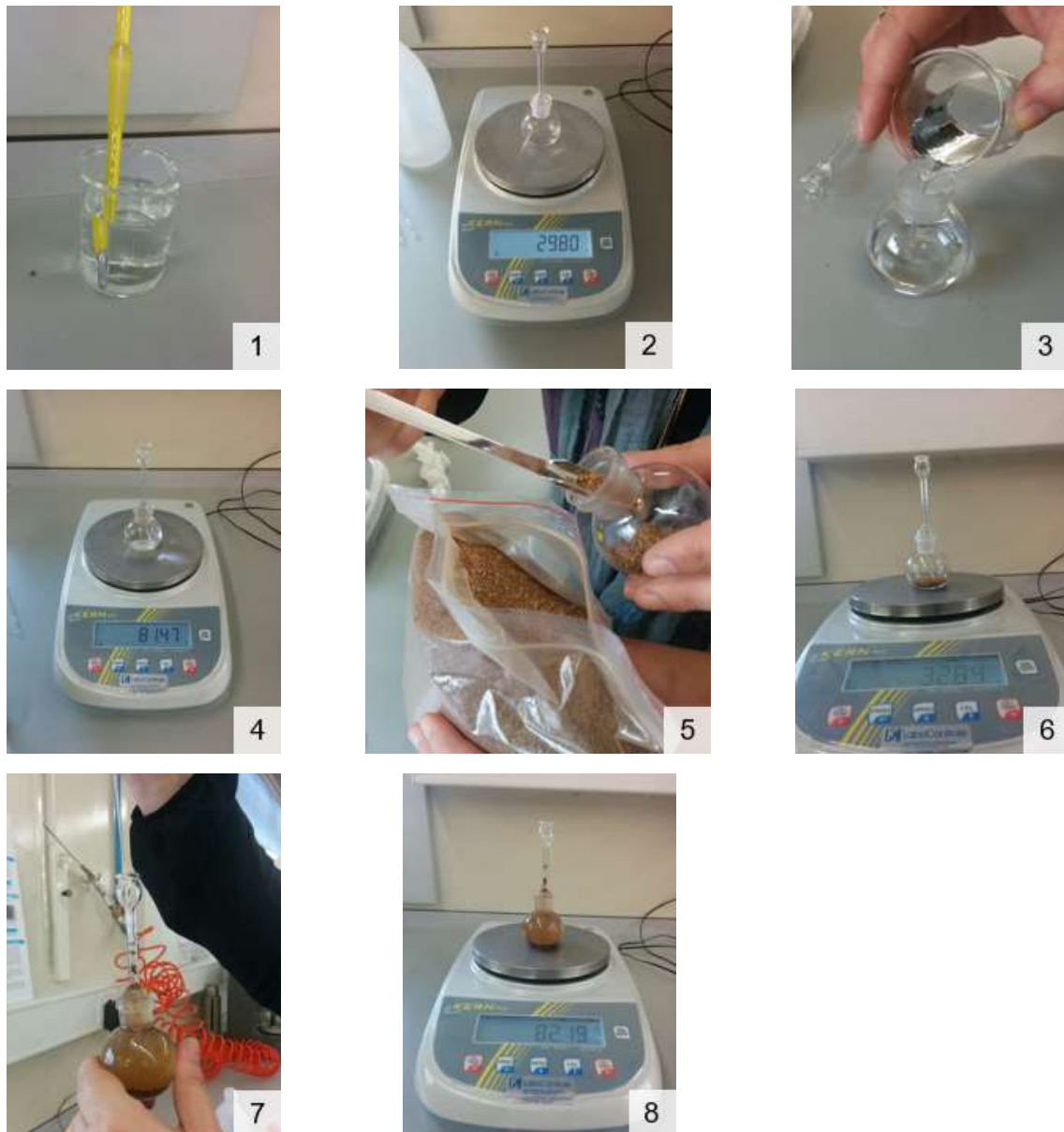
Besides the experimental work to find which material to apply in the product that will be developed, some additional experimental work has been made. Thus, an experimental process to find the density of the almond by-products was carried out, as well as, the visualization, under the microscope, of the following 3D printing wires: PLA + coffee and PLA + wood fibres. Regarding this, determining the density of the almond by-products will help to know what to expect about the mass of the bio-composite material, since the PLA density is already known from the manufacturer and the microscopic observation was due to, at a certain moment of this work, the interest in producing 3D printing wire of this bio-composite in order to be able to print a prototype of the developed product with the bio-composite here presented. This analysis will be important to understand the size of the fibres/particles in available wires in the market, as well as, understand the percentage of reinforcement in the wires. However, due to the complete impossibility to find available equipment to extrude the bio-composite with the diameter of 1.75mm or 3mm, this objective was abandoned but the experimental work that has been made still proves to be interesting. Bearing this in mind, both experimental works will be presented further down.

#### 3.1.4.1. Almond by-products density determination

Acknowledging the density of the almond by-products is just one of the many steps for the characterization of a material. Regarding that the almond by-products are already

mixed when they are acquired and that they had been grinded and milled all together, the density is determined by using the grinded almond by-products. Recalling that the objectives of this research aim at the use of all the almond nuts industry waste, which includes hulls, shells and skins and ignoring the fact that they are acquired all mixed, which will also avoid extra costs due to the sorting of the waste before being used. However, by observing the material that has been acquired, it is clear that there is a much higher quantity of shells than hulls and skins. This may be due to the fact that many producers of almond meat buy the almond nuts without hulls and, also, to the fact that they produce almond meat both with and without skin.

Being aware of such reality it was necessary to determine the density of the almond by-products, so a pycnometer for solid materials as then used. This process is very accurate even though, it will be repeated five times in order to calculate the mean of the results. Such procedure avoids any possible mistake during the process as well as it considers five different samples of grinded almond by-products, which, in turn, contain different percentages of hulls, shells and skins. Regarding this, Figure 60 shows the process to determine the density of the material. Notice that for determining the density four another times, it is only necessary to repeat the process from step 5 to 8, since the steps before can be used the same values for all.



**Figure 60:** Process for determining the density of the almond by-products using a pycnometer for solid materials.

- 1) Measurement of the temperature of the distilled water using a thermometer in order to acknowledge its density;
- 2) Measurement of the mass of the completely empty pycnometer;
- 3) Filling of the pycnometer up to its maximum with distilled water and no air bubbles;
- 4) Measurement of the mass of the pycnometer filled with distilled water;
- 5) Placing of a small quantity of almond by-products in the pycnometer;
- 6) Measurement of the mass of the pycnometer with the almond by-products;
- 7) Filling of the pycnometer containing the almond by-products up to its maximum with distilled water and without air bubbles;

- 8) Measurement of the mass of the pycnometer containing the almond by-products and filled with distilled water.

Table 20 that follows, shows all the measurements to proceed to the determination of the density of the almond by-products.

	Temperature of	Measurement
	Distilled water	18°C
	Mass of	Measurement
	Completely empty pycnometer	29,80g
	Pycnometer filled with distilled water	81,47g
	Mass of pycnometer with almond by-products	Mass of pycnometer with almond by-products and filled with distilled water
Sample 1	32,84g	82,18g
Sample 2	34,35g	82,36g
Sample 3	34,34g	82,44g
Sample 4	33,20g	82,26g
Sample 5	33,76g	82,37g

**Table 20:** Results of the measurements of the temperature using a thermometer and of the mass using a pycnometer to determine the density of the almond by-products.

With the results thus obtained, the density can be determined by using the following formula,

$$\rho_{almond\ by-products} = \left( \frac{B - V}{B - V - C + A} \right) \rho_{H_2O} \quad [g/cm^3]$$

in which  $V$  represents the mass of the completely empty pycnometer,  $A$  represents the mass of the pycnometer filled with distilled water,  $B$  represents the mass of the pycnometer with almond by-products and  $C$  represents the mass of the pycnometer with almond by-products and filled with distilled water. The density of the distilled water at 18°C is 0.998g/cm<sup>3</sup>. Thus, after solving the formula for each sample, the results are presented below.



Sample	Density determination [g/cm <sup>3</sup> ]
1	1,302
2	1,24
3	1,269
4	1,300
5	1,292
Mean	1,281

**Table 21:** Determination of the density for each sample of almond by-products.

Considering this, the density of the almond by-products all mixed is 1,281g/cm<sup>3</sup>. Note that this value may vary according to the percentage of hulls, shells and skins in the samples. However, for this research, this value is going to be used as reference for the acquired almond by-products. Considering that the value of the PLA given by the manufacturer is of 1,24g/cm<sup>3</sup>, the almond by-products are few dense than the PLA from *NatureWorks*<sup>®</sup>.

### 3.1.4.2. Microscopy visualisation and analysis of 3D printing wire

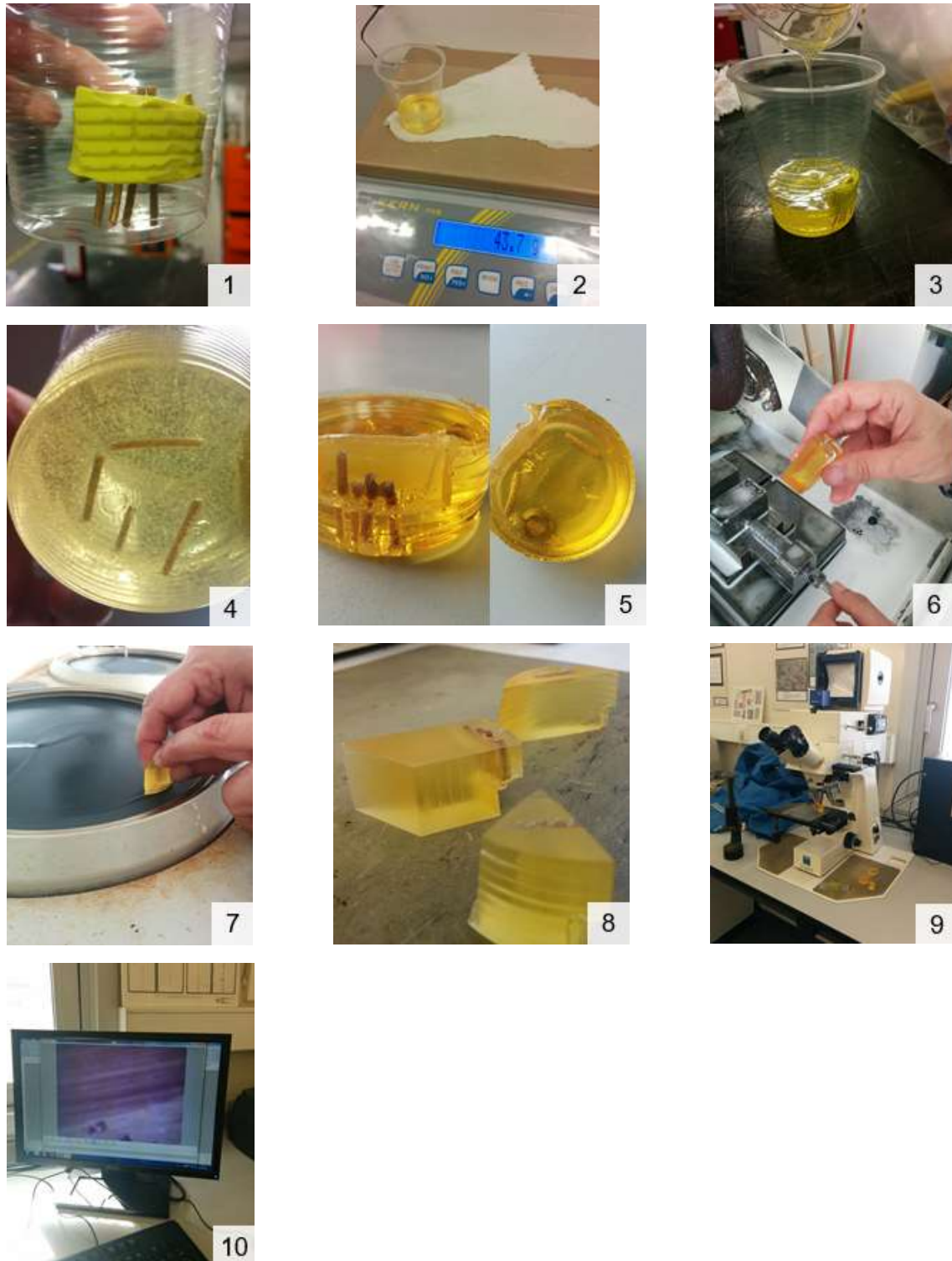
As abovementioned, the microscopic visualization of the 3D printing wires of PLA reinforced with coffee particles and wood fibres (Figure 61), which were available and provided by the Laboratory of Product and Services Development in the Department of Mechanical Engineering at FEUP, was important to understand the size of the particles/fibres, as well as its percentage in the wires.



**Figure 61:** 3D printing wires – PLA + wood fibres on the left, and PLA + coffee particles on the right.

Both by handling and by observation of the 3D printing wires, it is possible to check that the wire containing wood fibres (WWF) has a much higher content of it than the wire containing coffee particles (WCP). Due to this higher content, the WWF presents a high level of roughness and it is fragile. Regarding the WCP, the low content of coffee particles is easily observed among the PLA due to its transparency, while in the WWF this is not possible. Besides this, the WCP is far less fragile than the other wire and has a low level of roughness.

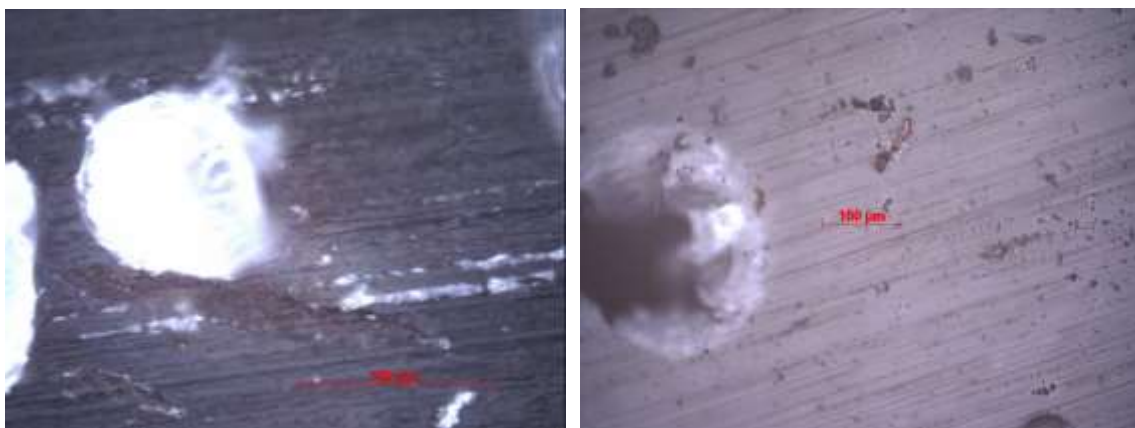
After this first analysis, the next step was observation of the wires using a microscope, but first it was necessary to prepare samples for it. Considering that to observe a material sample in the microscope the sample must have a polished surface and the size and shape of the wires was not the most appropriate to obtain such samples, it was necessary to use epoxy resin, which was available at INEGI, in order to make it easier to obtain a wider surface for polishing. Regarding this, the whole process to obtain the samples for observation in the microscope is shown below (Figure 62).

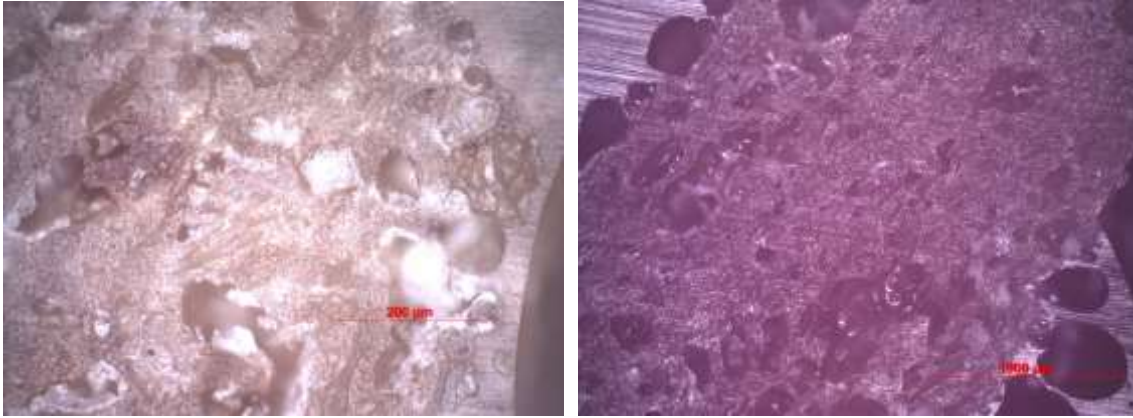


**Figure 62:** Process of preparation of the samples till the microscope observation.

- 1) Preparation of two fractions of each wire, both in the vertical and horizontal positions, in a plastic cup. The vertical fractions have been held in place with the help of glue pads;
- 2) Preparation of the Sicomin SR 1500 epoxy resin by mixing it with the Sicomin SD 2505 hardener in another plastic cup, with the relation in mass of 100/33, respectively;
- 3) Pouring of the resin into the plastic cup with the 3D printing wire fractions;
- 4) The resin was placed in the laboratory to cure for at least 24h;
- 5) After the resin was cured, the plastic cup was removed to get the new solid material;
- 6) The material has been cut into three parts to make polishing easier. This process was carried out by using a cut-off petrographic machine, Remet TR 60;
- 7) The three parts of the material, have been polished in the grinding and polishing machine, Struers RotoPol-21, using SiC foils with the following order of grit: 80, 180, 320 and 800. With this process, it was possible to prepare the samples for observation in the microscope;
- 8) Samples after being polished and ready for observation;
- 9) Microscope for observation of the samples;
- 10) Monitor, connected to the microscope, displaying the image captured by the eyepiece.

The observation of the samples, both with the wires in vertical and horizontal positions, showed a lot of bubbles of air in the wires. These might have formed on account of the chemical reaction of the resin while being cured. Another possibility may be that, due to the polishing process some small particles may have been removed and empty holes left similar to bubbles of air. Figure 63 shows these results, both for WCP and WWF.





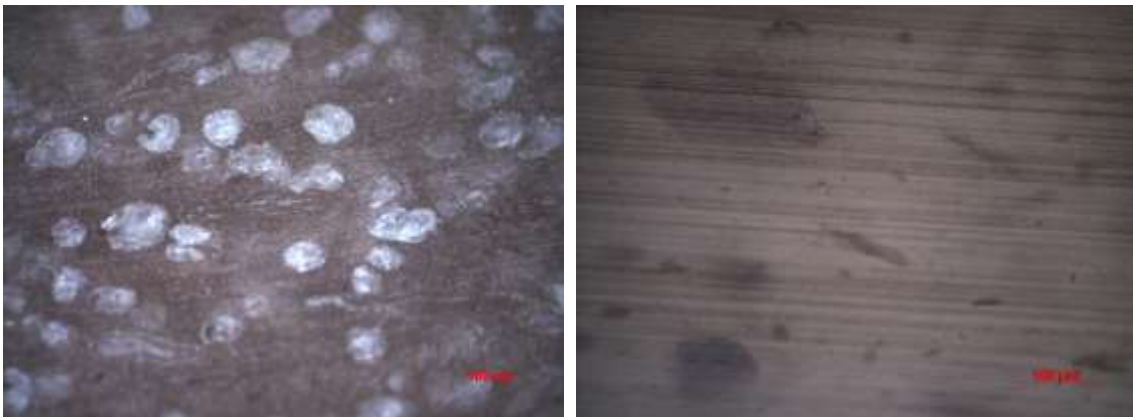
**Figure 63:** Observation of the samples – on the left, wires in the vertical position and, on the right, wires in the horizontal position; WCP on the top and WWF on the bottom.

After the results of the first observation, a new sample using a different process than the abovementioned was prepared. Thus, a fraction of each wire was glued into a small metal bar to ease the polishing procedure. This process avoids any chemical reactions as those that may happen with the epoxy resin. So, the result of the new sample is shown on Figure 64.



**Figure 64:** Second sample – WWF on the left and WCP on the right.

By observing this sample under the microscope, it was possible to obtain better and more perceptible pictures of both wires so being easier to analyse. Below is one image from the microscope of each wire Figure 65.



**Figure 65:** Example of one image of each wire from the second sample – WWF on the left and WCP on the right.

Unfortunately, the equipment necessary for a precise and exact analysis of the wires was not available. Considering this, the decision was to proceed to a direct analysis of 7 pictures taken during the observation on the microscope and calculate the difference between the total area of the picture and the area occupied by the particles or fibres. In the end, the mean of all results for each wire was calculated in order to have a notion of what percentage of reinforcement they have. Regarding this, Figure 66 presents an example for each wire of how this has been made as well as a table with all the results (Table 22). All the edited pictures are present on Appendix II.



**Figure 66:** Example of how it was calculated the percentage of reinforcement in each wire – WWF on the left and WCP on the right.

WWF		WCP	
Picture	Percentage of Wood Fibres	Picture	Percentage of Coffee Particles
WWF1	23.89%	WCP1	12.42%
WWF2	16.73%	WCP2	6.01%
WWF3	15.63%	WCP3	8.30%
WWF4	22.55%	WCP4	9.72%
WWF5	16.57%	WCP5	7.23%
WWF6	17.43%	WCP6	12.83%
WWF7	19.68%	WCP7	13.16%
WWF Mean	18.93%	WCP Mean	9.95%

**Table 22:** Results of the analysis of the pictures of each wire.

According to the results presented on the table above, the WWF has, approximately, 20% of reinforcement while the WCP has only, approximately, 10%. However, it is important to mention that this method isn't precise and/or exact. Besides this, while it is possible to see almost all the coffee particles due to their low content and thus easier to analyse, the same doesn't happen with the WWF, in which only the fibres in the surface are visible. As abovementioned, the necessary equipment for an accurate

analysis was not available. So, decision to use this method even though not being the most indicated, provided a notion of the percentage of reinforcement in each wire.

Besides this, the size of the WCP particles varies, somewhat in-between 20 $\mu\text{m}$  and 200 $\mu\text{m}$ , while the WWF fibres varies, more or less, between 50 $\mu\text{m}$  and 125 $\mu\text{m}$ .

### 3.1.5. Experimental work conclusions

Regarding all the experimental work, the obtained results were positive and promising despite most of the experiments were made using rudimentary methods and without following any set standard. The fact that almond by-products are considered an industrial and organic waste, using them as a reinforcement in polymer matrix, besides giving to them a new purpose, will also extend their life cycle. Thus, regarding the origin of both materials, PLA and almond by-products, this created composite may be considered a bio-composite, so environment friendly.

In order to know the bio-composite and confirm its suitability as a raw material, it is necessary to carry out its characterization following set standards. Thus, tests, such as, for example, mechanical, thermal, physical, chemical, morphological and rheological characterization should be carried out to understand the behaviour of the material under stress and specific conditions. Besides this, new experimental work should be carried out but using appropriate equipment to proof its viability for large scale manufacturing, as well as LCA of the material. However, this will only be considered for future work.

## 3.2. Application of the bio-composite: design proposal

Up to this moment, the focus of the case study was the creation of a bio-composite using a biodegradable bio-based polymer, PLA, and one type of organic waste: almond by-products. Now, as previously defined in the objectives present in chapter 1.4, the intention goes on apply this material in a product that will be developed and presented along this chapter. Note that the bio-composite created in chapter 3.1.2, after being characterized, may be applied in any product as long as its properties meet the requirements of the manufacturer.

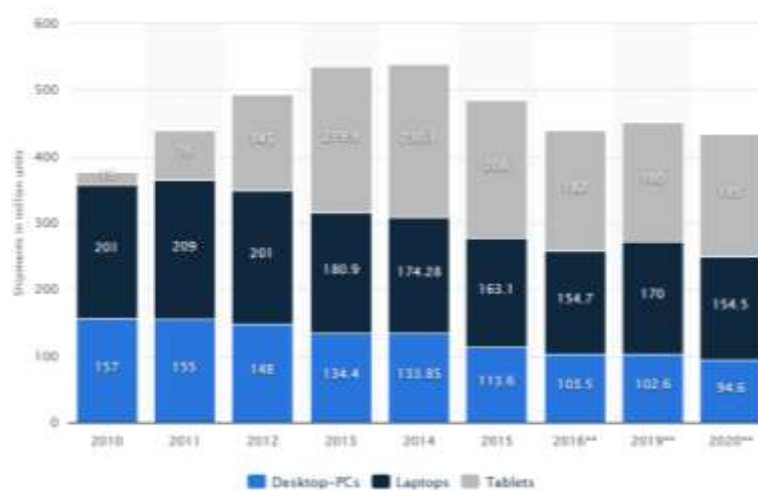
Thus, considering the literature review about *Ingeo™* and the fact that almond by-products will, most probably, decrease the biodegradation time of the bio-composite, the use of this product will have to take into consideration the actual environmental issues. As aforementioned in chapter 1.2, the high production and consumerism of non-biodegradable plastics from non-renewable resources has been strongly contributing to an increase in pollution, and, associated with it, a significant increase with environmental problems on Earth. With this material, the product also follows the principles of the Zero-Waste philosophy, which intends to appeal to the “designing of products (...) that systematically avoid and eliminate the volume and toxicity of waste and materials, conserve and recover all resources, and not burn or bury them”.

However, when designing a product, the designer, besides having high environmental awareness criteria, he must also take into consideration the experience of the user with the product so that it can be successful in the market. For this, the designer should consider several aspects which range from the moment a person looks at the product in the stores to the moment when that person becomes its user and keeps using it for a long period of time and also the moment the product reaches its end-of-life. Thus, factors such as affordance, aesthetics, functionality, usability and/or ease of use, ergonomics, reliability and durability, affordable, and, as abovementioned, sustainable and environment friendly.

With this in mind, chapters that follow will focus on the problem that is intended to be solved as well as the ideation of solutions for it. As soon as this is defined, some research with inspirations to create the concept of the product and its development process will be presented. Finally, when the development whole process ends, a 3D model of the product and its prototype will be created in order to proceed to the usability tests.

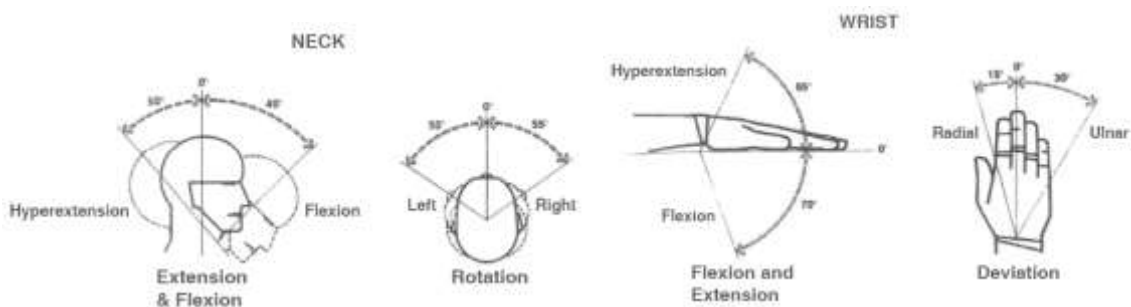
### 3.2.1. Problem definition and ideation

It is an undeniable fact that nowadays almost every person aged over 18 owns either a computer desktop (PC) or a laptop, or both. This makes it very hard to acknowledge the exact number of people using PCs or laptops. However, analysing the graph provided by *Statista* regarding the shipment of PCs, laptops and tablets from 2010 to 2015 and the forecast for 2016, 2019 and 2020, it is expected that the sales of PCs will decrease while the sales of laptops may maintain within the approximate numbers (Figure 67).



**Figure 67:** Shipment of laptops, desktop PCs and tablets worldwide from 2010 to 2015 and forecast to 2016, 2019 and 2020 (Statista).

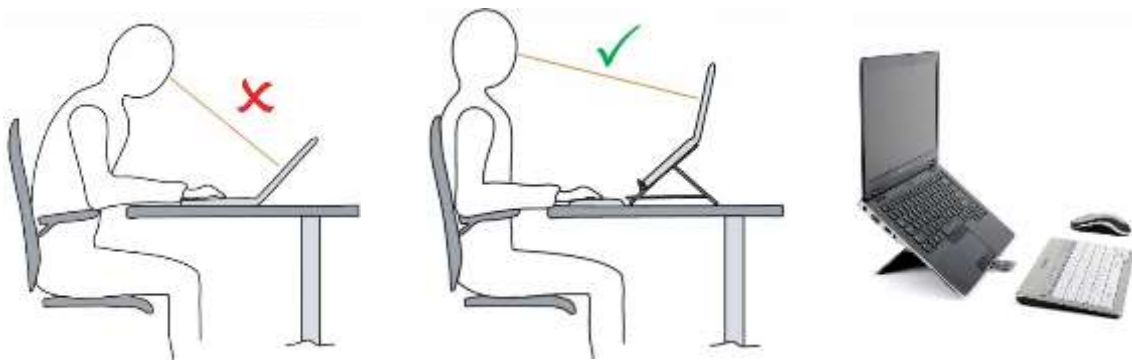
This data may be regarded as an indicator for the increasing of people using laptops. The portability of laptops maybe the main reason for the expected increasing rate of users, since they can be adopted to great variety of positions on different working stations and users are able to assume a great variety of postures, while PC users usually have to be in a seated position working at a desk. However, laptops increase the exposure to potential risk factors for musculoskeletal disorders comparing to PCs, since the height of the laptop display is lower than recommended but also for perfect visualization because the keyboard is part of the computer itself. PC and laptop users working at a desk may be subject to having health risk factors, such as: wrist ulnar deviation, wrist extension, elbow flexion, shoulder flexion, trunk extension and neck flexion and rotation (Gold et al. 2012) (Figure 68).



**Figure 68:** Movements associated with neck flexion and rotation, and wrist extension and ulnar deviation (adapted from Panero and Zelnik 2013).

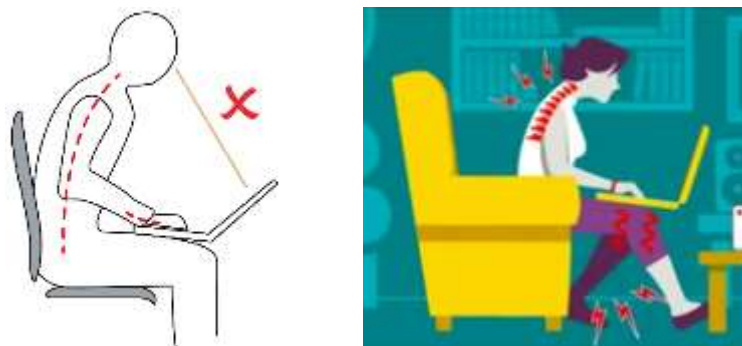
Considering this and due to the particular characteristics of laptops, users usually present higher neck flexion, resulting in a higher forward bent of the head and trunk inclination that may cause lesions on those body parts (Asundi et al. 2012) (Figure 69). Thus, it is recommended to use a laptop stand with an external mouse or, preferably, a laptop riser with external mouse and keyboard (Asundi et al. 2012) (Figure 69). The last option will be similar to working at a desk while using a PC, thus providing a better working posture, and using an external mouse will avoid wrist extension.





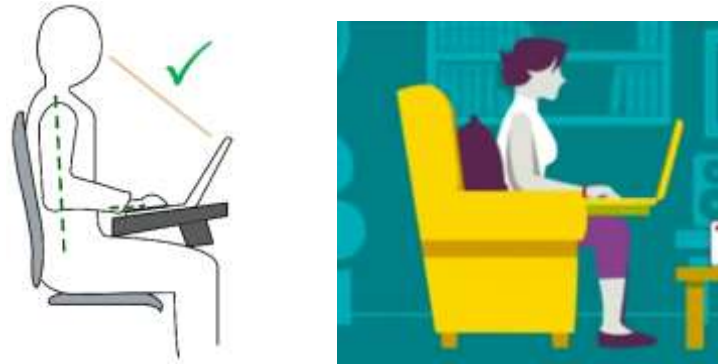
**Figure 69:** Differences of the posture while working with and without a riser with external devices, as shown by the example on the right (Bakker Elkhuisen).

Despite the fact that many people use their laptops on a desk, they can be adopted to a great variety of working environments, thus being widely used either by students or by professionals. This means that the image of people using their laptops while traveling by bus, train or airplane is far too common. Apart from long-distance trains and airplanes, which may provide minimum working conditions for passengers, buses, short-distance trains and short-distance airplanes, in order to obtain the maximum use of the available space so as to by accommodate as many passengers as possible, there aren't any working conditions for passengers. This way, any passenger of these public transports, who intends to work or simply know about the latest news while travelling, usually places the laptop on his/her lap. However, in the absence of a suitable surface to place the laptop work, the passengers seek to adopt a more comfortable posture while working, which usually forces them to assume a posture that leads to higher neck flexion and wrist extension as well as ulnar deviation, as shown in Figure 70 (Moffet et al. 2002). Besides the bad postures adopted by laptop users while working on the lap, they also may suffer from "toasted skin syndrome" (TNN 2016). This syndrome, which is clinically known as Erythema Ab Igne, can cause permanent discoloration of the skin and, in rare cases, cancer if laptop users place the laptop on their lap for long periods of time, since the laptops can reach from 40°C to 52°C (TNN 2016; Macrae 2010). Finally, Doctor Anuya Manerkar defines it as "a coarsely reticulated pigmentation which is produced by prolonged exposure to excessive heat without the production of burn" (TNN 2016).



**Figure 70:** The most common posture adopted by laptop users while working on the lap - image on the left by Bakker Elkhuisen and image on the right by Vodafone (adapted from Bakker Elkhuisen; Schofield 2013).

Thus, according to many entities, doctors and researchers' advice, laptop users working on their laps, should place something, such as a laptop stand, under the laptop, be it a tray or even a book, that may rise the laptop thus providing a better working posture for the users, as well as, avoiding the exposure to the heat from the laptop, as shown in Figure 71 suggested by Bakker Elkhuisen and Vodafone (Schofield 2013). However, besides placing an object to rise the laptop, these don't usually offer the possibility to use an external mouse, thus avoiding a high level of the wrist extension.



**Figure 71:** Two different entities suggestions of using an object to place under the laptop while working on the lap – image on the left by Bakker Elkhuisen and image on the right by Vodafone (adapted from Bakker Elkhuisen; Schofield 2013).


Regarding the abovementioned facts and in order to go further on this study, the next decision was to make a search of products available in the market, not only to place the laptop while working on the lap, but also to place on a desk, since they may be multifunctional and provide more information. According to the results of the search for these products, the information collected will be very important to define the pros and cons of each of them and thus ease the development of a new product and open the way to innovation.


### 3.2.2. Benchmarking

In order to achieve a higher probability of success with a new product, it is important first to analyse and measure the quality of similar products available in the market. Through benchmarking analysis, it becomes easy to evaluate the pros and cons of products available in the market, thus defining what and where products can be improved and use this information in the development of a new product.


Unfortunately, during this process, it was not possible to acquire any of the selected products, so only the images and specifications from the manufacturers' website were used to assess them. Regarding this minor drawback and based on the abovementioned available data, an analysis of laptop stands to use on the lap, also known as lapdesks, and to use on a desk, assessing the following criteria: weight, size (length x width x height), material (metals, plastics, woods, fabric, leather and/or rubber), usability (able to use on the desk, lap or both), multifunction (able to use for smartphones and/or tablets), height adjustability, possibility of using external mouse (yes or no) and ease of transport (easy, medium or hard) (Table 23) was carefully undergone. It is important to refer the existence of several other products with similar


specifications and designs. However, while selecting the products to assess, there was an effort to choose different products able to be used on the lap, desk or both, yet more indicated to be used on the lap. The benchmarking study is presented in the table below.


Brand:	[kg] Weight:	Unknown
Actto	[mm] Size (LxWxH):	578 x 280 x 7 [mm]
	Material:	Plastic
	Height adjustability:	Yes
	Usability:	Desk and lap
	Multifunction:	Only laptops
	External mouse:	Yes
Model:	Transport:	Easy
NLD-01	Notes:	It isn't possible to use both, height adjustability and external mouse, at the same time.
<a href="http://www.actto.com">www.actto.com</a>		


Brand:	[kg] Weight:	Unknown
Woody Life	[mm] Size (LxWxH):	228 x 260 x 8
	Material:	Bamboo
	Height adjustability:	Yes
	Usability:	Desk and lap
	Multifunction:	Only laptops
	External mouse:	No
Model:	Transport:	Easy
Up	Notes:	The product has two angles to adjust height; it seems to be low weight and it has three parts to be assembled.
<a href="http://www.woodylife.me">www.woodylife.me</a>		


Brand:	[kg] Weight:	1,8
Bakker Elkhuisen	[mm] Size (LxWxH):	391 x 374 x 64
	Material:	Fabric and unknown type
	Height adjustability:	No
	Usability:	Desk and lap
	Multifunction:	Only laptops
	External mouse:	No
Model:	Transport:	Easy
ErgoTraveller	Notes:	This product can be used as a laptop bag or stand; an unknown rigid material is used.
<a href="http://www.bakkerelkhuisen.com">www.bakkerelkhuisen.com</a>		


Brand:	[kg] Weight:	0,23
Stood	[mm] Size (LxWxH):	291,5 x 100 x 18
	Material:	Beech wood
	Height adjustability:	No
	Usability:	Desk
	Multifunction:	Only laptops
	External mouse:	No
Model:	Transport:	Easy
Wooden Laptop Stand	Notes:	According to the manufacturer, the product can be used on any surface but it doesn't seem to be adaptable to be used on the lap.
<a href="http://www.stood.it">www.stood.it</a>		


Brand:	[kg] Weight:	0,82
Logitech	[mm] Size (LxWxH):	370 x 260 x 12
	Material:	Plastic
	Height adjustability:	No
	Usability:	Lap
	Multifunction:	Only laptops
	External mouse:	Yes
Model:	Transport:	Easy
Portable Lapdesk N315	Notes:	The product has an inner extensible/sliding surface for the use of an external mouse.
www.logitech.com		


Brand:	[kg] Weight:	1,09
Logitech	[mm] Size (LxWxH):	458 x 286 x 73
	Material:	Plastic and fabric
	Height adjustability:	No
	Usability:	Lap
	Multifunction:	Only laptops
	External mouse:	No
Model:	Transport:	Medium/Hard
Comfort Lapdesk N500	Notes:	Depending on the size of the laptop, the use of an external mouse may be possible.
www.logitech.com		


Brand:	[kg] Weight:	1,04
RLDH – Rodolfo Lozano	[mm] Size (LxWxH):	406,4 x 304,8 x 50,8
	Material:	Bamboo or walnut wood
	Height adjustability:	No
	Usability:	Lap
	Multifunction:	Only laptops
	External mouse:	Yes
Model:	Transport:	Easy/Medium
Tablio Mini Desk	Notes:	Two sliding surfaces for external mouse or other stuff; its height makes it not so easy to transport.
<a href="http://www.rl-dh.com">www.rl-dh.com</a>		

Brand:	[kg] Weight:	1,65
AIDATA	[mm] Size (LxWxH):	420 x 310 x 75
	Material:	Plastic
	Height adjustability:	0°, 15°, 20°, 25° and 30°
	Usability:	Desk and lap
	Multifunction:	Only laptops
	External mouse:	Yes
Model:	Transport:	Medium
LD007 / LD007P	Notes:	This product is available with and without cushion. It also contains built-in USB cooling fan.
<a href="http://www.aidata.com">www.aidata.com</a>		


Brand:	[kg] Weight:	1,41
LapGear®	[mm] Size (LxWxH):	571,5 x 304,8 x (?)
	Material:	Wood grain PVC and fabric
	Height adjustability:	No
	Usability:	Lap
	Multifunction:	Laptops and smartphones
	External mouse:	Yes
Model:	Transport:	Medium/Hard
Deluxe Laptop LapDesk™	Notes:	This product has two cushions so its height must be considerable; the handle helps in the transportation.
www.lapdesk.com		

Brand:	[kg] Weight:	Unknown
Royal Craft Wood	[mm] Size (LxWxH):	558,8 x 279,4 x (?)
	Material:	Bamboo
	Height adjustability:	No
	Usability:	Lap
	Multifunction:	Laptops, tablets and smartphones
	External mouse:	Yes
Model:	Transport:	Medium
Lapdesk Slate	Notes:	None
www.royalcraftwood.com		

Brand:	[kg] Weight:	2,22
iSkelter	[mm] Size (LxWxH):	642,6 x 347,5 x 19,05
	Material:	Bamboo and rubber
	Height adjustability:	No
	Usability:	Desk and lap
	Multifunction:	Laptops, tablets and smartphones
	External mouse:	Yes
Model:	Transport:	Hard
Hover X LapDesk	Notes:	According to the manufacturer mentions that it is possible to use this product on a desk but it does not look comfortable.
www.iskelter.com		

Brand:	[kg] Weight:	1,81
iSkelter	[mm] Size (LxWxH):	571,5 x 393,7 x 12,7
	Material:	Bamboo and leather
	Height adjustability:	No
	Usability:	Lap
	Multifunction:	Laptops, tablets and smartphones
	External mouse:	Yes
Model:	Transport:	Hard
Comfy Lite	Notes:	It contains a cushion for the wrist; Mousepads for left and right-handed users.
www.iskelter.com		



Brand:	[kg] Weight:	0,91
iSkelter	[mm] Size (LxWxH):	15" Laptop – 571,5 x 292,1 x 25,4
	Material:	Bamboo
	Height adjustability:	No
	Usability:	Lap
	Multifunction:	Only laptops
	External mouse:	No
Model:	Transport:	Medium
Comfy Pad LapDesk	Notes:	Size for 11" and 13" laptops – 463,6 x 254 x 25,4 [mm]. Handles make it easier to transport but it is somewhat to big.
www.iskelter.com		

**Table 23:** Benchmarking study of laptop stands and/or lapdesks (Actto; Woody Life; Bakker Elkhuizen; Stood; Logitech; RLDH; Aidata; LapGear®; Royal Craft Wood; iSkelter).

Analysing the summarized information regarding the benchmarking study of lapdesks and/or laptop stands, it is possible to verify that there is a great variety of products in terms of design, size, material, height adjustability, usability, multifunctionality and the possibility of being used with an external mouse. However, bearing in mind the most important features for a lapdesk, which were considered to be the height adjustability, the possibility to use on the lap (usability), the possibility to use with smartphones and/or tablets and/or laptops (multifunctional), the possibility to use an external mouse and if it is easy is to transport the product considering its size and weight, a matrix has been made to compare the products from the benchmarking and check if any product have all these characteristics. The matrix is presented below (Table 24).

Model \ Features	Height adjustability	Usability (lap)	Multifunctional	External mouse	Transport (easy)
NLD-01	(1)	X		X	X
Up	X	X			X
ErgoTraveller		X			X
Wooden Laptop Stand					X
Portable Lapdesk N315		X		X	X
Comfort Lapdesk N500		X			
Tablio Mini Desk		X		X	X
LD007 / LD007P	X	X		X	
Delux Laptop LapDesk™		X	X	X	
Lapdesk Slate		X	X	X	
Hover X Lapdesk		X	X	X	
Comfy Lite		X	X	X	
Comfy Pad Lapdesk		X			
(1) – When using this product as a lapdesk, it is not possible to have height adjustability.					

**Table 24:** Matrix of needs to compare the most important features of the products of the benchmarking.

According to Table 24, none of the products meets all the features. Despite being more indicated to be used on the lap, only some of the selected products have a cushion below in order to comfortably fit on and only one of them has a small cushion for the wrist. Besides this, not all products have a sliding surface that can make the use of an external mouse possible. This last feature has a huge impact on transportation since the lapdesks have to be significantly bigger if they are not able to be closed at least as far as the surface for the mouse is concerned, as well as the presence of cushions. There is also the possibility to place smartphones and/or tablets in a vertical position on some of the lapdesks. The product manufactured by Aidata is the unique product in this group that is able to adjust the height of the laptop while using the external mouse, but its size and weight are considerable for transportation.

In terms of material, there is a trend in the market to buy products made of wood, which was possible to conclude along this study. However, wood increases the manufacturing cost of the products so it comes with no surprise that many manufacturers still choose plastic for their products. Moreover, composites using resins or polymers blended with organic waste, such as, for example, wood fibres and coffee grinds, aesthetically similar to wood, are becoming more and more common. Finally, *N315* from *Logitech*, *Tablio* from *RLDH* and *LD007* from *Aidata*, where considered as the most interesting products to place the laptop while working on the lap. These products allow the use of an external mouse since they have a sliding surface as well as a comfortable size, approximately similar to a 15” or 17” laptop when the sliding surface is closed. Even so, all products

have pros and cons, and these three don't break the rule. The model from Logitech is the smallest one, which seems the ideal, but it doesn't have heat ventilation and height adjustability. Regarding the *Tablio Mini Desk* from *RLDH*, in terms of length and width it is good for transportation but the height is considerable, and there is no possibility of height adjustability. Finally, the *Aidata's* product proves to be a lot more functional since it allows height adjustment even though it is too big for easy transportation.

Bearing all the abovementioned details in mind, it becomes pertinent to develop a new solution for a lapdesk and/or laptop stand to place on the lap while using a laptop by filling some of existing the gaps in the products of the benchmarking study, so a product that meets all the features mentioned in the matrix of needs.

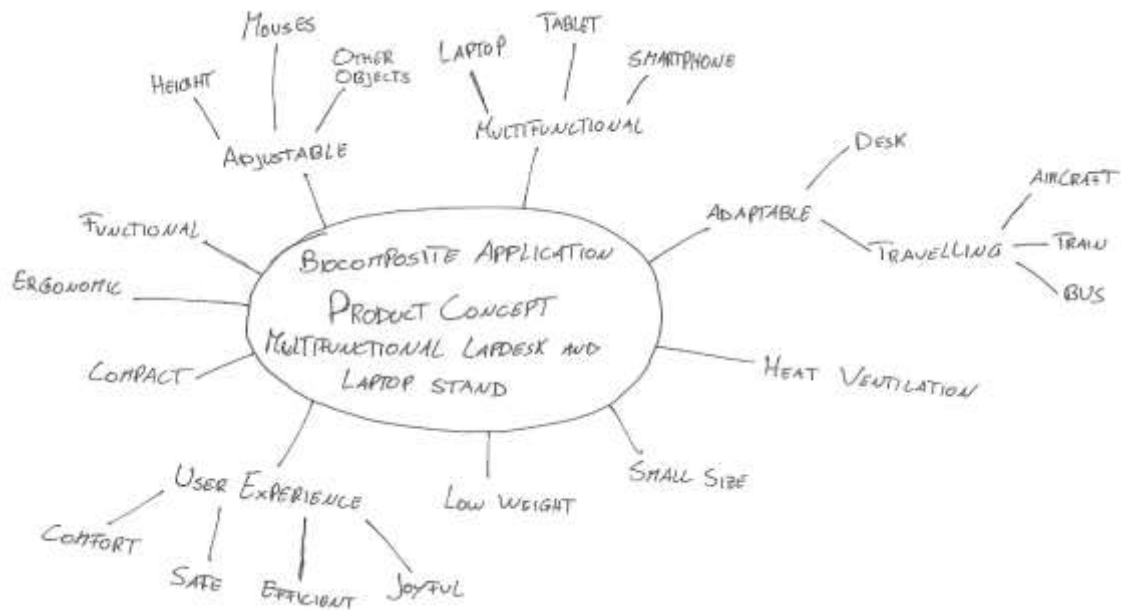
### 3.2.3. Product concept

When submitted to a new challenge, a designer should have a great number of thoughts and questions to successfully achieve the ideated product. In sequence and the reasons presented in chapters 3.2.1 and 3.2.2, came the decision to design a product which must be ergonomic, functional and compact. As Figures Figure 70 and Figure 71 show, it is important to bear in mind and be aware that human body posture and/or the dimensions of the product should be appropriate for human use, which means they should provide comfort, safety and an efficient, productive and joyful experience (adapted from Panero and Zelnik 2013). Regarding functionality of the product, it must be user-friendly and include some features such as, height adjustability as well as the possibility to use an external mouse. Besides all those, it will be designed to hold smartphones and tablets. Finally, the main reason that motivated this product research is the fact that many people who frequently travel by train, bus and/or airplane often use their laptop on the lap to work or have some joy of time. Thus, it is fundamental that the product must be compact, and low weight, in order to fit in most of the bags occupying the least space possible.

*“Designers have the opportunity to create something new, or redesign something to make it better”* (adapted from Papanek 1995).

Bearing in mind the abovementioned facts, the statement from Papanek and the fact that innumerable and different products already exist, both lapdesks and/or laptop stands, it is greatly challenging to design a new product with similar features yet more efficient than all the existing ones. The inspiration for the new product to be designed came from a gathering of the best features of *N315* from *Logitech*, *Tablio* from *RLDH* and *LD007* from *Aidata*. So, the intention to design this new product stretches from a small size as in *N315*, to the possibility of height adjustability as in *LD007*, to the practicability of heat ventilation as in *LD007* and *Tablio*, but also the existing of a sliding surface for the use of an external mouse as in all the three products. Finally, and as an added value feature, the possibility of using the product as a smartphone or tablet stand will also be added.

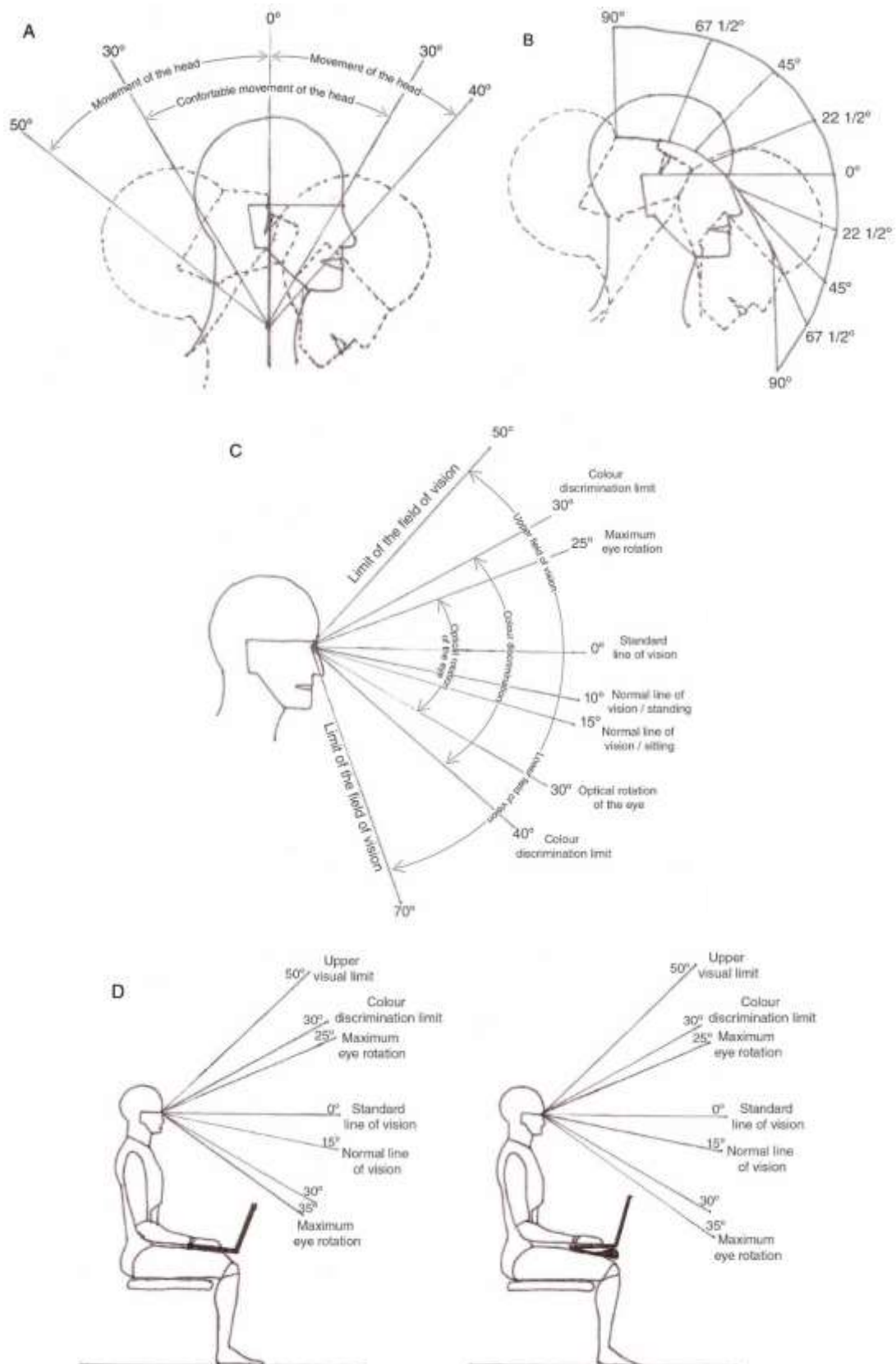
The mind map for the product concept, which follows, summarizes what is intended to develop (Figure 72).



**Figure 72:** Mind map created for the product concept.

### 3.2.4. Ergonomics applied to the product

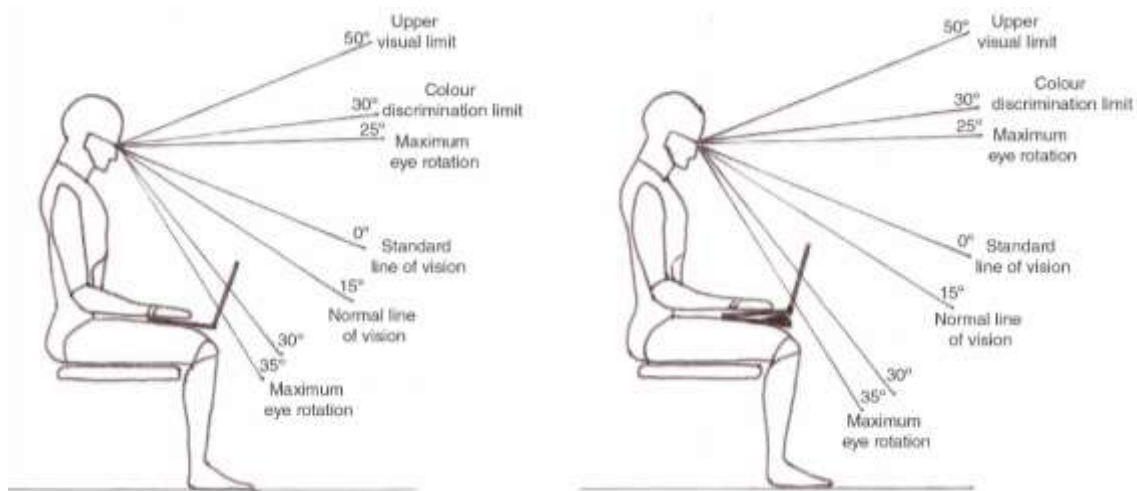
Before proceeding to the design of the product, there was an obvious requirement of going through an ergonomic study. When creating a product, designers, engineers and architects are requested to devise products for a great variety of people which implies the knowledge of the corporal dimensions and functional design issues in order to appropriately respond to the required needs (adapted from Panero and Zelnik 2013). However, in this case, the corporal dimensions aren't so important as the movements and joint positions of the neck, wrist and eyes. While corporal dimensions will not have a big impact on the efficiency of the product, knowing the movements and joint positions of the human body will help to develop a product which is sensible to the well-being of the user. In fact, laptops are already designed taking into consideration the human corporal dimensions. So, lapdesks or laptop stands are designed for the laptops to improve the working position of the user. Thus, it is important to know and study the comfortable movements of the neck, wrist and eyes as well as the field of vision of the eyes. Below are presented a set of images taken and adapted from the Portuguese edition of the book "Human dimension & interior space – A source book of design reference standards", written by Panero and Zelnik, in order to understand these movements and how a lapdesk can improve the working position of a user (Figure 73).



**Figure 73:** Images that show the movement of the head in the vertical plain (A), the range of movements of the head and eyes in the vertical plane (B), the field of vision in the vertical plane (C) and field of vision with the head at zero degrees (D) (adapted from Panero and Zelnik 2013).

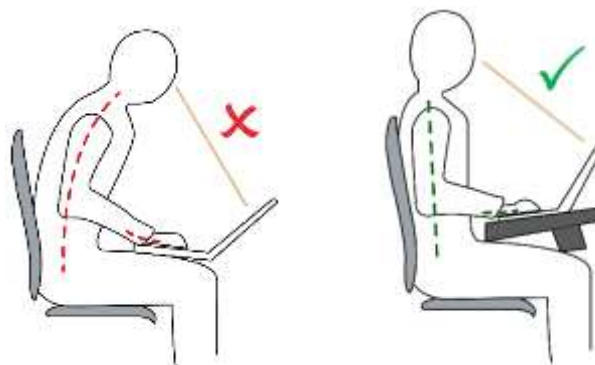
Observing Figure 73 (A), it is possible to understand that the comfortable movement of the head is  $30^\circ$  in both directions relative to the vertical axis, and the field of vision is greater between  $30^\circ$  above of the standard line of vision and  $40^\circ$  below it (Figure 73 (B)). Thus, considering the standard line of vision for an angle of the head at  $0^\circ$  (Figure 73 (D)), it is possible to verify that a person using a laptop on the lap will not have a good field of vision over the laptop.

Adapting Figure 73 (D) for a head angle of  $22,5^\circ$ , and the standard line of vision also at  $22,5^\circ$ , it is possible to verify that the user already has a comfortable field of vision over the laptop (Figure 74).



**Figure 74:** Field of vision with the head and the standard line of vision at 22.5 degrees (adapted from Panero and Zelnik 2013).

Note that the laptops, either with and without a lapdesk, adapted in Figure 73 (D) and Figure 74 are merely representative. However, this representation helps to perceive the difference of using a lapdesk for the wrist and field of vision while using a laptop on the lap. Despite not representing the difference for the posture, as they were adapted from an image with a person sitting in straight position with the head at  $0^\circ$ , chapter 3.2.1 mentions the difference for the wrist and posture of the user when he is using a lapdesk while working with a laptop on the lap. Thus, as shown above in Figures Figure 69, Figure 70 and Figure 71, the figure below displays the advantages of using a lapdesk to place a laptop while working on the lap (Figure 75).



**Figure 75:** Differences in the posture and wrist while working with a laptop on the lap, with and without a lapdesk (adapted from Bakker Elkhuizen).

### 3.2.5. Product development – Design proposal

Throughout this chapter, all the product development will be presented, from the original sketches to 3D modeling and prototyping. Considering the information from chapters 3.2.1, 3.2.2, 3.2.3 and 3.2.4, which deal with problem and ideation, benchmarking study, product concept and ergonomics applied to the product, respectively, a design proposal for the identified problem will be as follows.

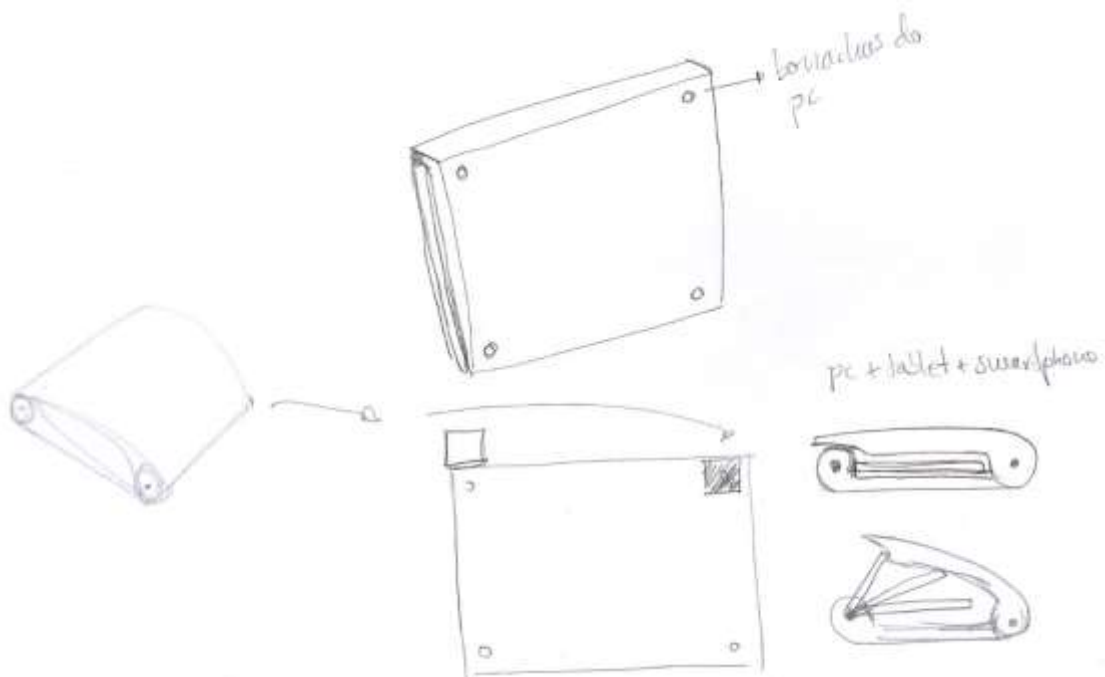
Thus, there is a product design constituted by three pieces: two multifunctional stands and one lapdesk. The corresponding product development processes, from the sketches to the prototyping, are going to be divided in two phases, since the multifunctional stand, after testing the prototype, suffered some modifications. As far as the lapdesk is concerned, its development process will appear in the sketches of phase 1 of the product development, but the 3D model and prototype will only appear in the phase 2. This decision was taken considering that the multifunctional stand is much more complex than the lapdesk, so it was decided to prototype and test it before proceeding to the 3D model and prototype of the lapdesk.

#### 3.2.5.1. Product development – Phase 1

Before achieving the final concept through sketches, different concepts were drawn, according to what is presented in Appendix III. Regarding the final concept, the development process of the multifunctional stand through sketches and the 3D model and prototype happened as shown below.

##### 3.2.5.1.1. Sketches

The following images, depict the development process of the multifunctional stand (Figure 76).



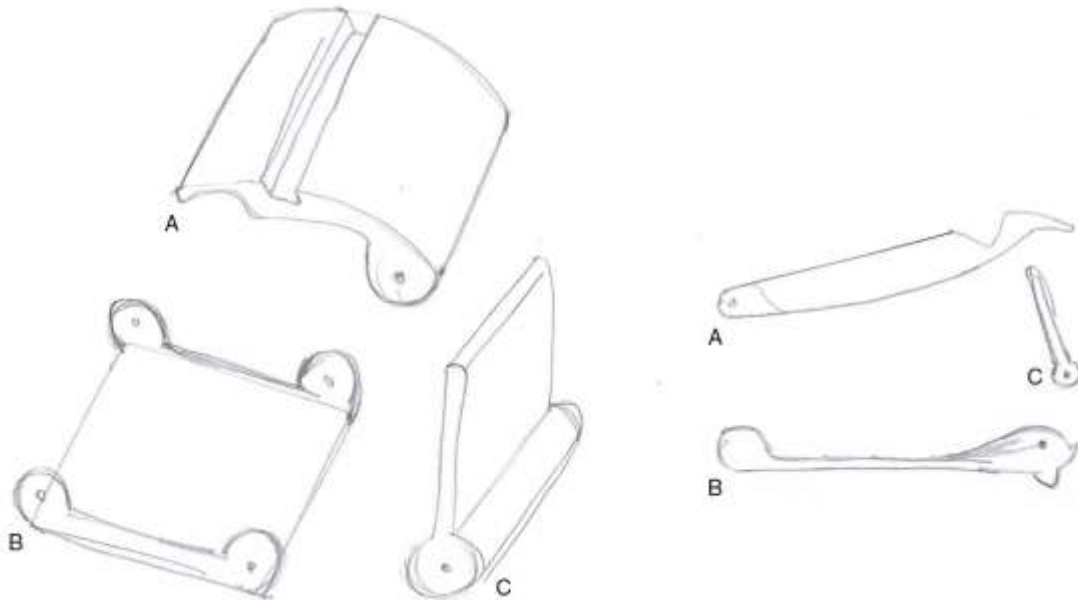




part that will be in direct contact with the different equipment. Finally, part *B* may be considered the middle part and it will hold part *A* for height adjustability.

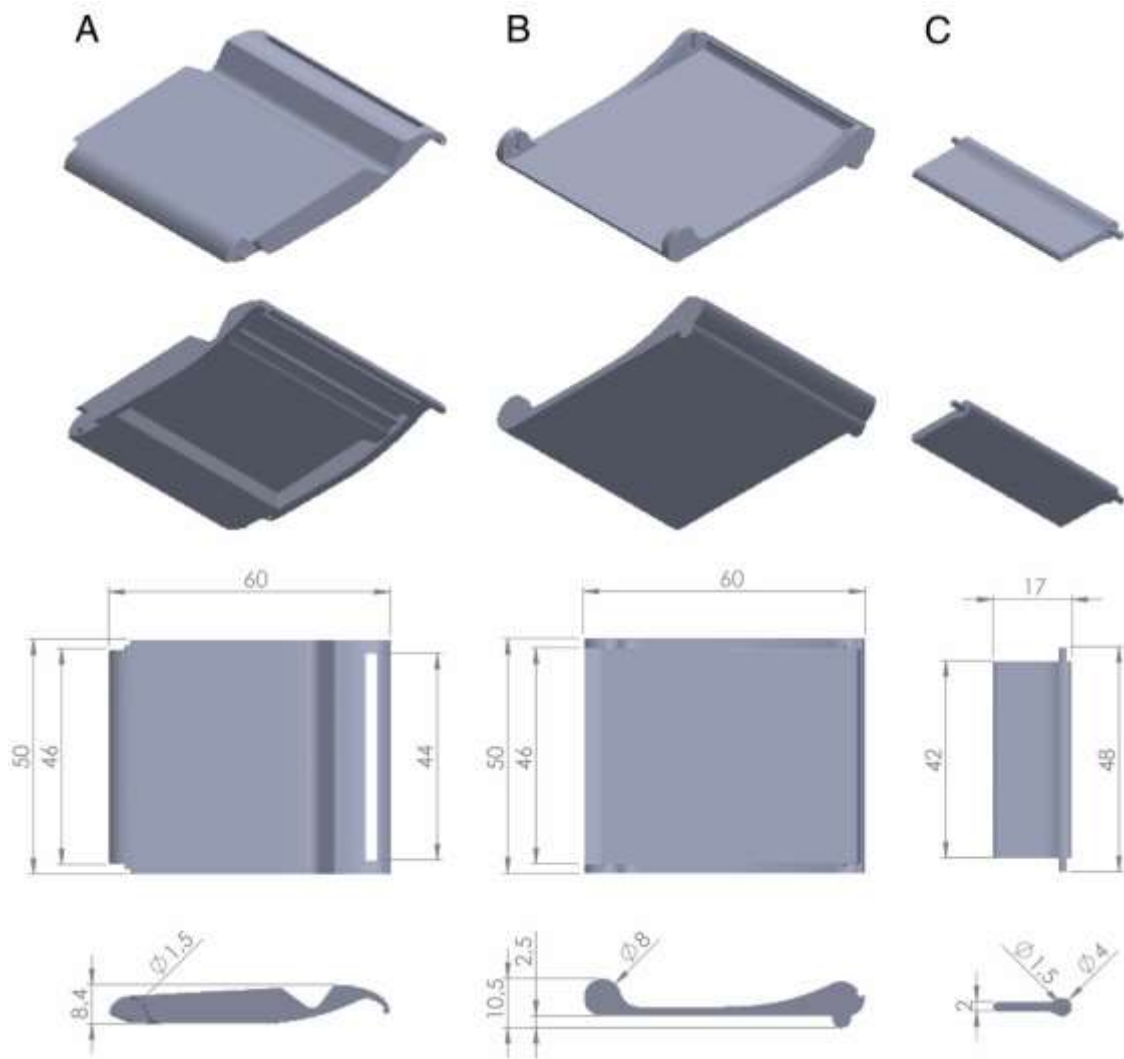
### 3.2.5.1.2. 3D modelling

By observing Figure 76, it is easy to understand that piece is constituted by three different parts, as identified below (Figure 77).



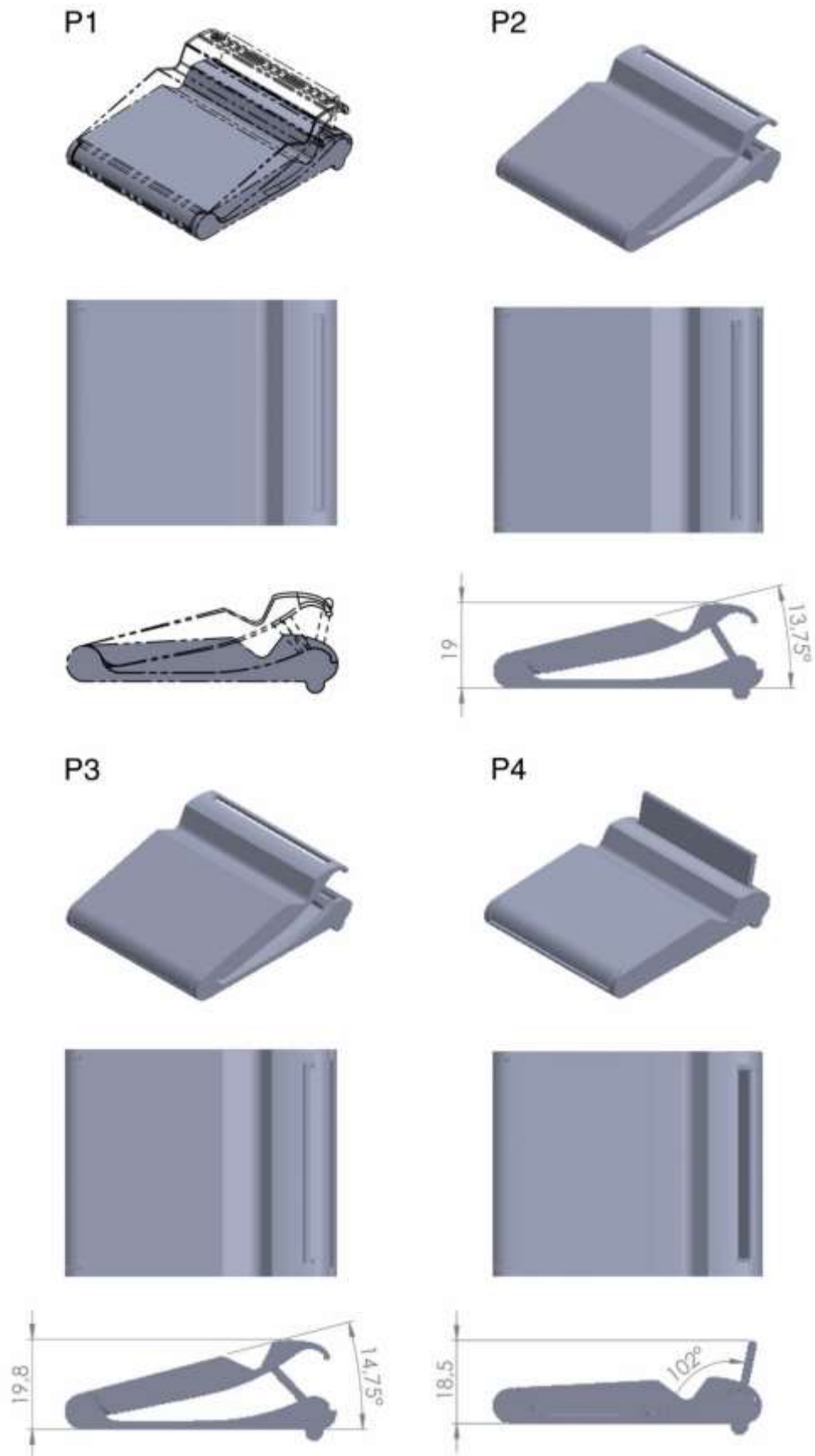
**Figure 77:** Different parts of the multifunctional stand.

Using *SolidWorks*, parts *A*, *B* and *C*, were modeled as shown in Figure 78. Besides those, some of the key dimensions of the product are also shown here.



**Figure 78:** Isometric (top and bottom), top and right views of the 3D model of the three parts of the multifunctional stand.

After assembling all the parts, it is possible to use the multifunctional stand for laptops, in three different heights and for tablets or smartphones. Below, on Figure 79, the assembled product is shown in all the possible configurations. Thus, image *P1*, besides presenting the main configuration of the product, also shows the other configurations with a different line to compare any differences for each configuration. Images *P2* and *P3* show the different height possibilities besides the main configuration. Finally, image *P4* shows the position to use with a tablet or smartphone.



**Figure 79:** Final product, with the three different parts assembled, representing all the possible configurations.

### 3.2.5.1.3. Prototype

The multifunctional stand is quite complex, so the decision was to make a prototype using a fused deposition modeling (FDM) 3D printer in a private home. Considering the shape of each part, this manufacturing process provides the best and cheapest prototype, as well as, it proved to be the easiest way to obtain it. The prototype is shown below (Figure 80).

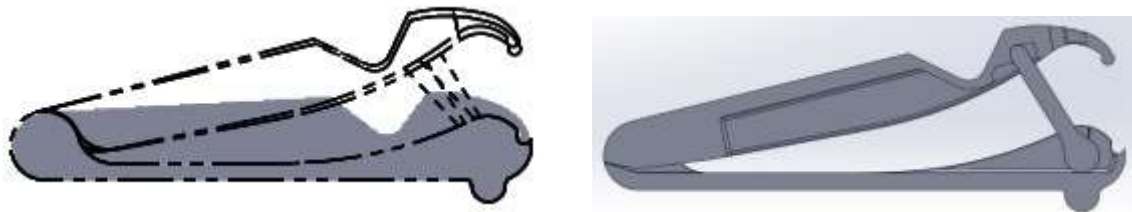


**Figure 80:** Prototype, using a FDM 3D printer, of the three parts and respective assembling with configurations *P1*, *P3* and *P4*.

Thus, after having access to all the parts and assembling them, it was quickly understood that it would be impossible to place any smartphone or tablet in the prototype of the multifunctional stand (Figure 81). The size of part C was too small and so it would not prevent the smartphone or tablet from toppling. Regarding the use of the stand for the laptop, it seemed to be functional. However, besides the fact that the two adjustable heights were very similar, it was hard to place part C in the correct position since they are hidden (Figure 82).



**Figure 81:** The multifunctional stand cannot prevent smartphones or tablets from toppling.



**Figure 82:** The different heights from configuration *P2* and *P3* and a section view from the right side of the assembling to demonstrate where part *C* should be placed by the user.

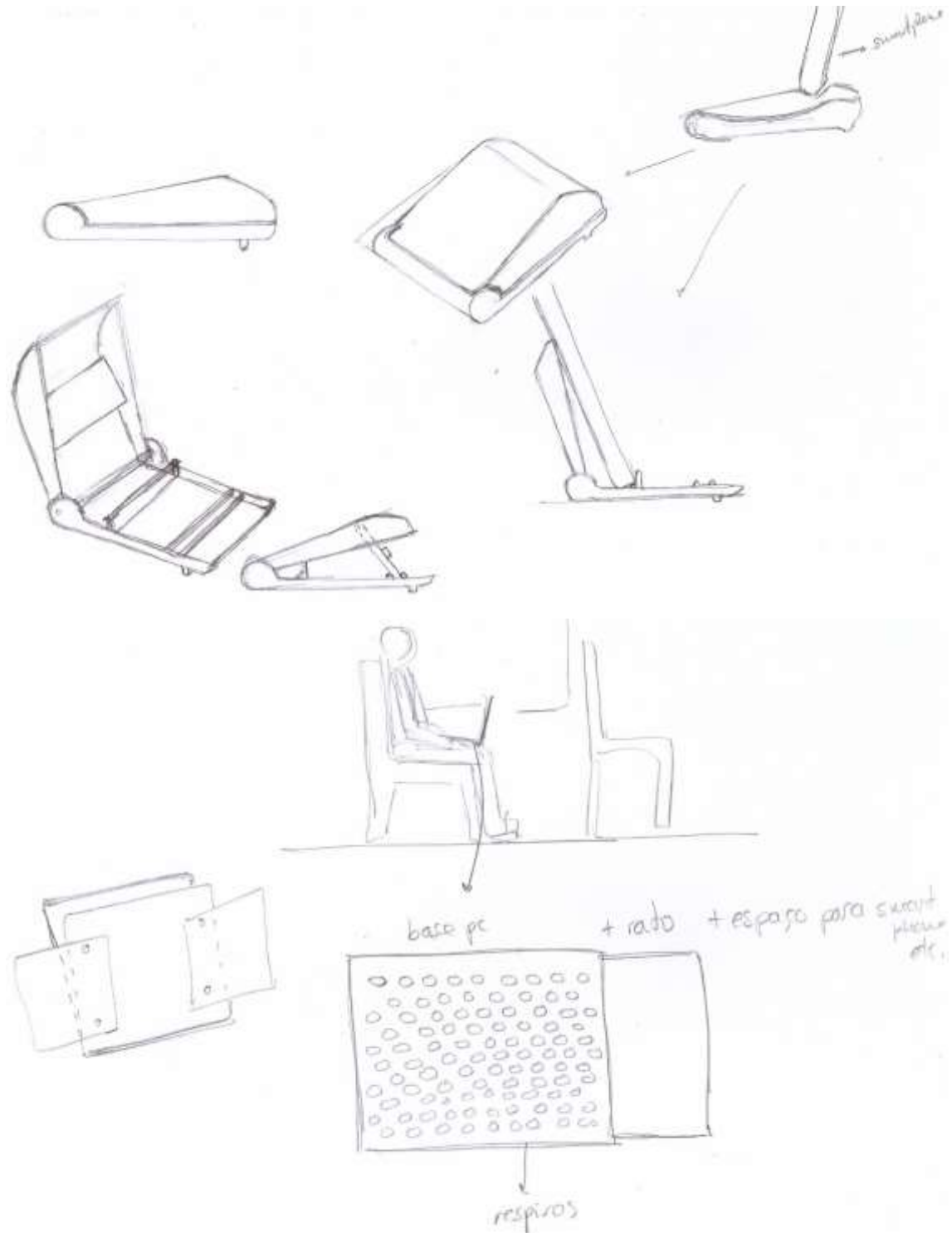
### 3.2.5.2. Product development – Phase 2

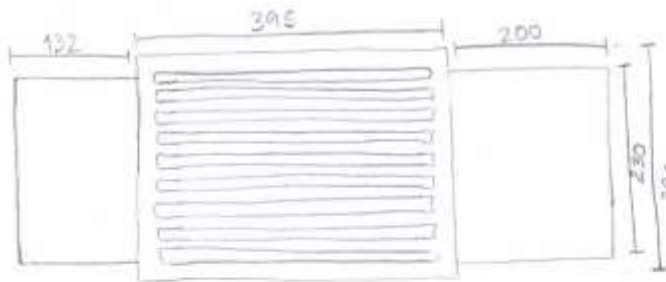
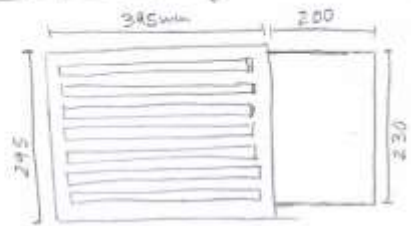
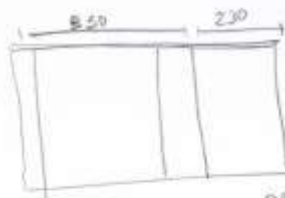
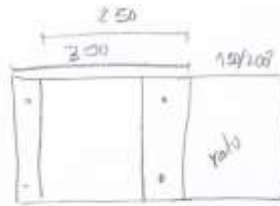
Considering the conclusions attained in chapter 3.2.5.1.3, many changes will have to be made yet without changing the concept of the product. Thus, it was decided to make part *A* as the one that will hold the tablet or smartphone. Regarding part *C*, its axis of rotation, instead of being on part *B*, will be on part *A* to make it easier to place in the intended position. Finally, considering that the axis of rotation is on part *A*, the notches will be designed on part *C*. Besides this they will be designed in order to have a greater difference of possible adjustable heights.

Besides this, also will be presented the sketches of the lapdesk, as well as its 3D model and prototype.

### 3.2.5.2.1. Sketches

On the following images, it is possible to see the development process and modifications on the multifunctional stand and the development process of the lapdesk (Figure 83).

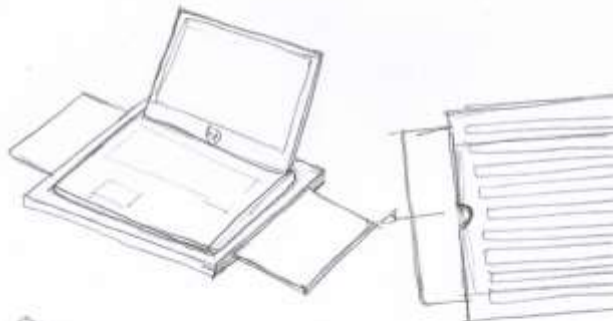




pc 15,6"



HP D116N



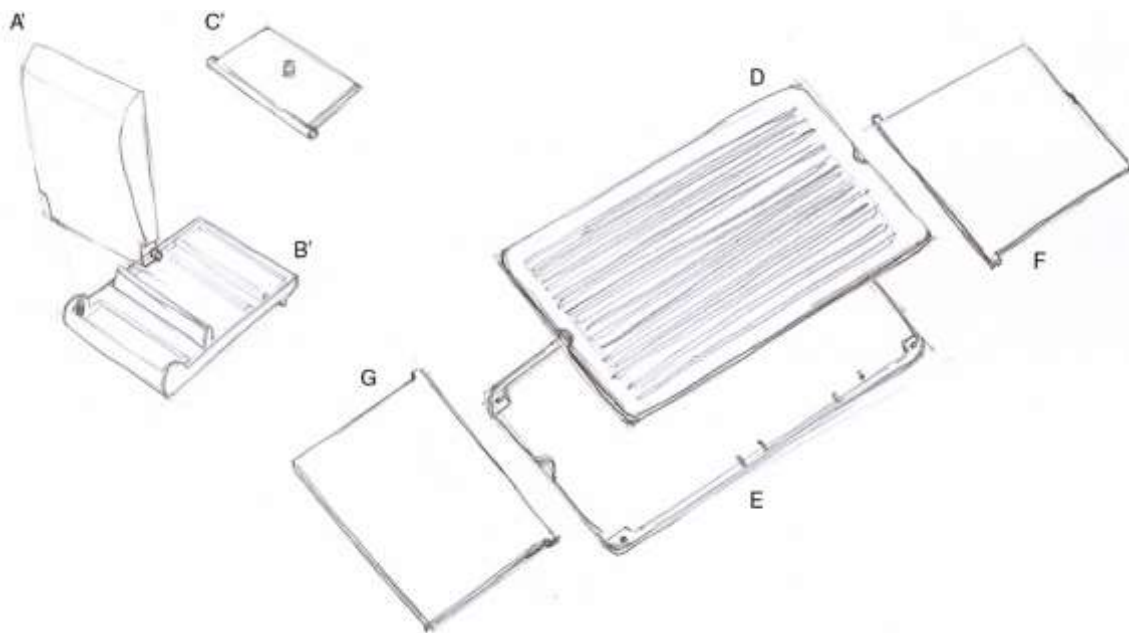


**Figure 83:** Development process and modifications on the multifunctional stand and the lapdesk in sketches.

Unlike the previous model of the multifunctional stand, during the study of the modifications to make the product functional, it was decided to assemble part *A'* in part *C'* and part *B'* in part *A'*. The sketches also present how it will be used. As far as the lapdesk is concerned, four parts constitute it. Bearing this in mind, part *D* is the top part of the product, where the multifunctional stand can be placed if the user desires to rise the back of the laptop, part *E* the base and parts *F* and *G* the surfaces, which will slide between the other two parts, for support while working and/or for the external mouse.

### 3.2.5.2.2. 3D modelling

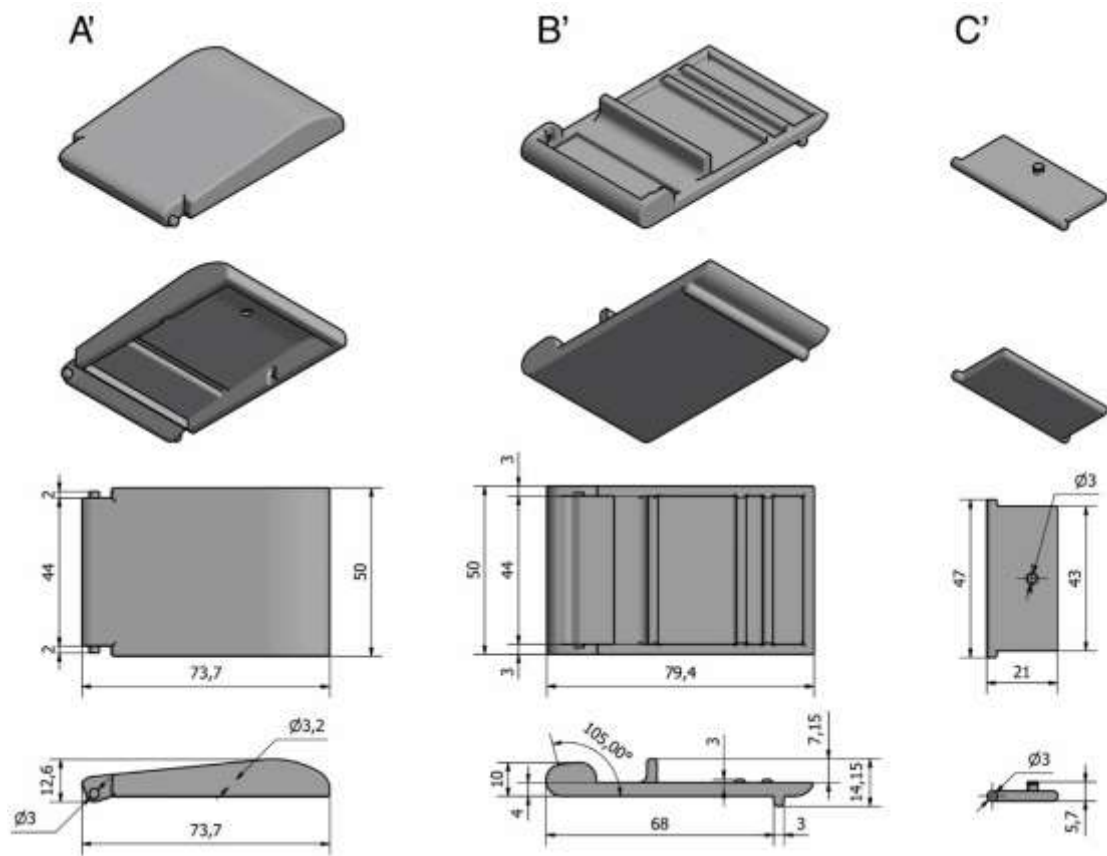
Regarding the new 3D model of the multifunctional stand, it will keep three parts but, instead of being named *A*, *B* and *C*, they will be named *A'*, *B'* and *C'*. Regarding the lapdesk itself, it will be constituted by four parts and, if necessary, some screws. Figure 84 shows the different parts of each product.

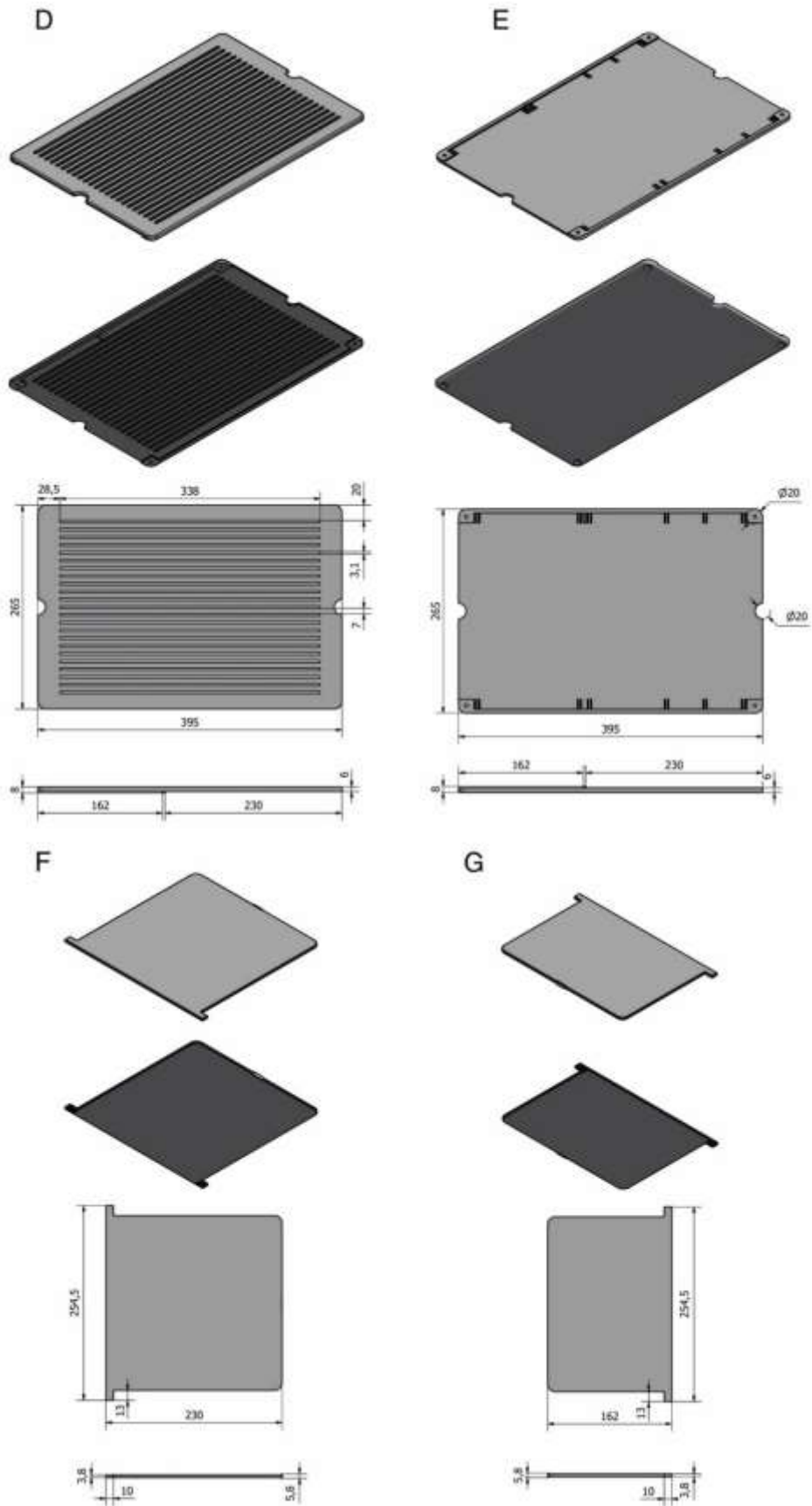


**Figure 84:** Different parts of the new multifunctional stand and of the lapdesk.



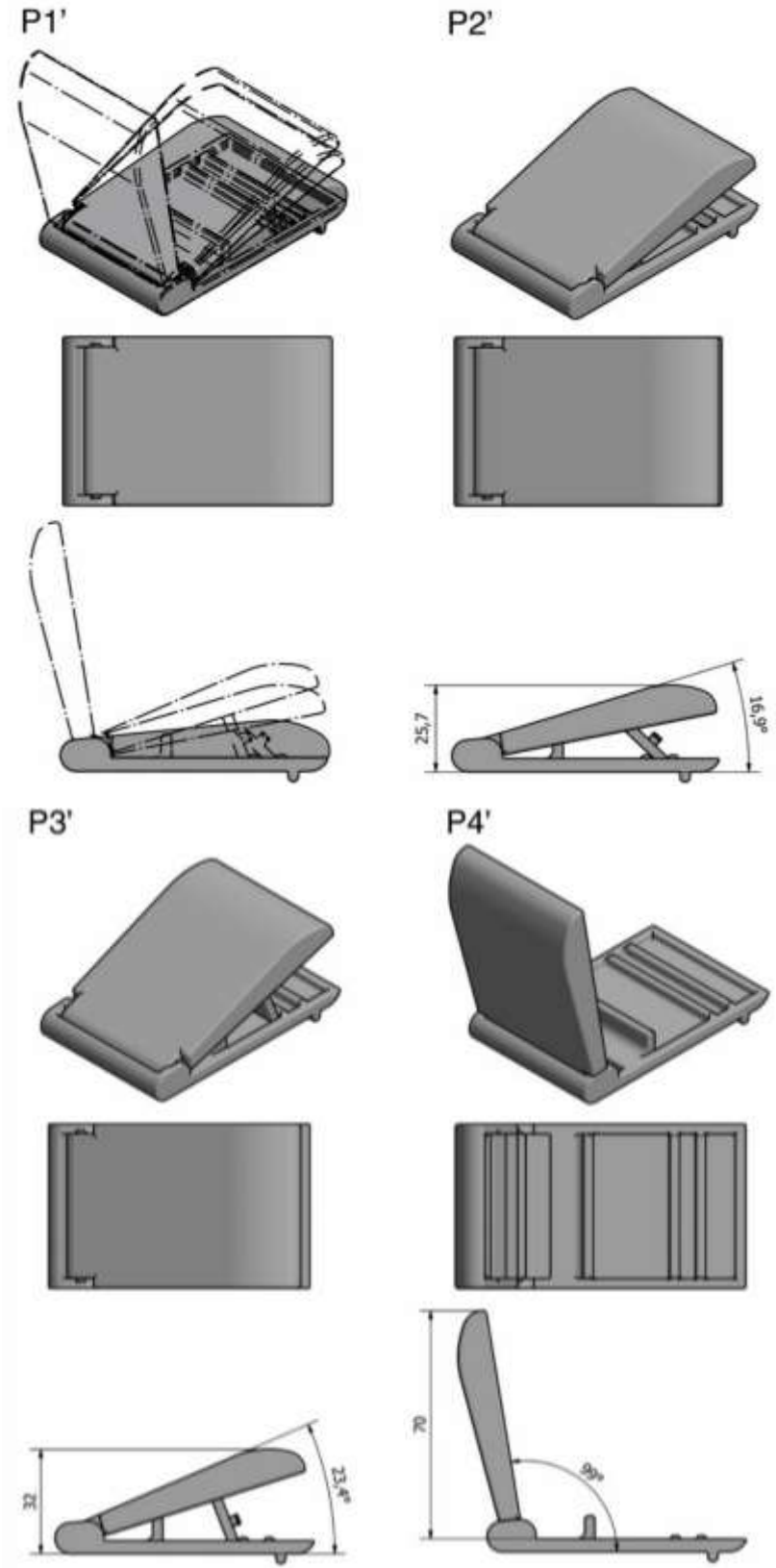
Thus, using *Autodesk Inventor*, parts *A'*, *B'*, *C'*, *D*, *E*, *F* and *G*, were modeled as Figure 85 shows. Some of the most important dimensions are also shown. For more detailed drawings see Appendix IV.

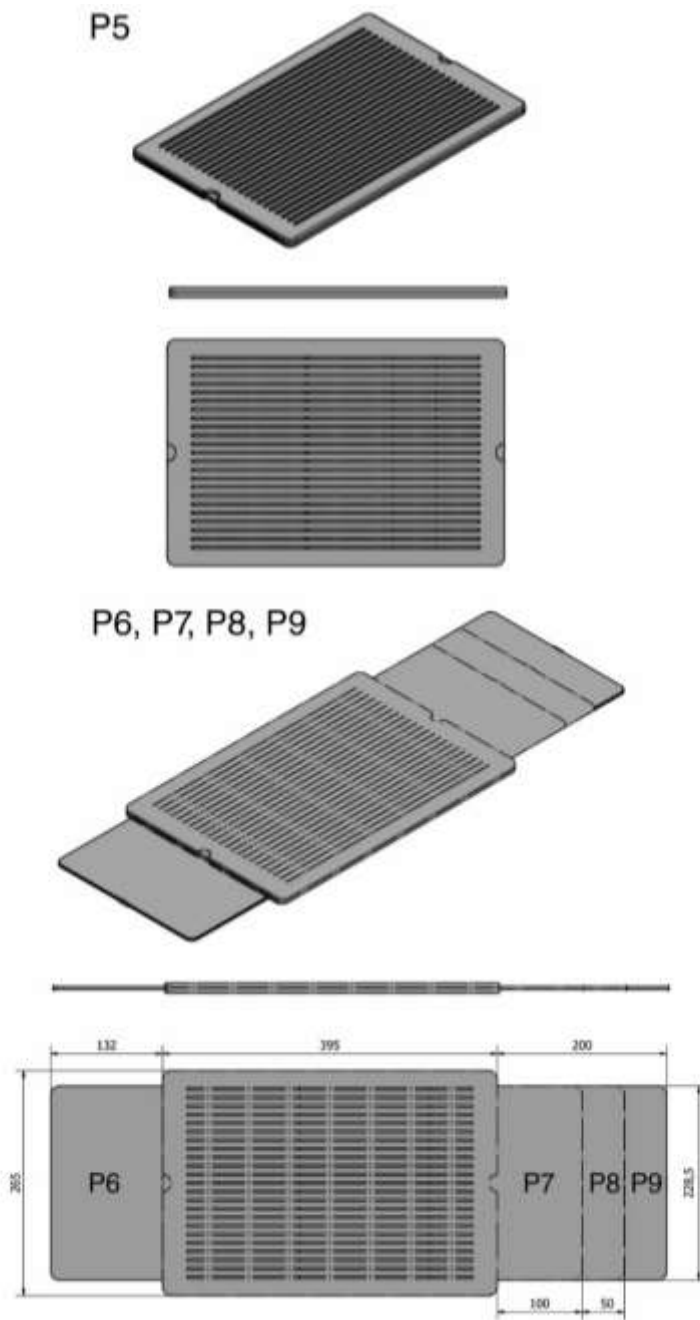




**Figure 85:** Isometric (top and bottom), top and right views of the 3D model of different parts of the multifunctional stand and lapdesk.

Figure 86 shows the assembling of all the parts in all the possible configurations of both products, the multifunctional stand and the lapdesk. Thus, P1', P2', P3' and P4' have the same meanings as P1, P2, P3 and P4. Regarding the lapdesk, image P5 presents the product fully closed, and images P6, P7, P8 and P9 present the product with the possible configurations for the two sliding surfaces.

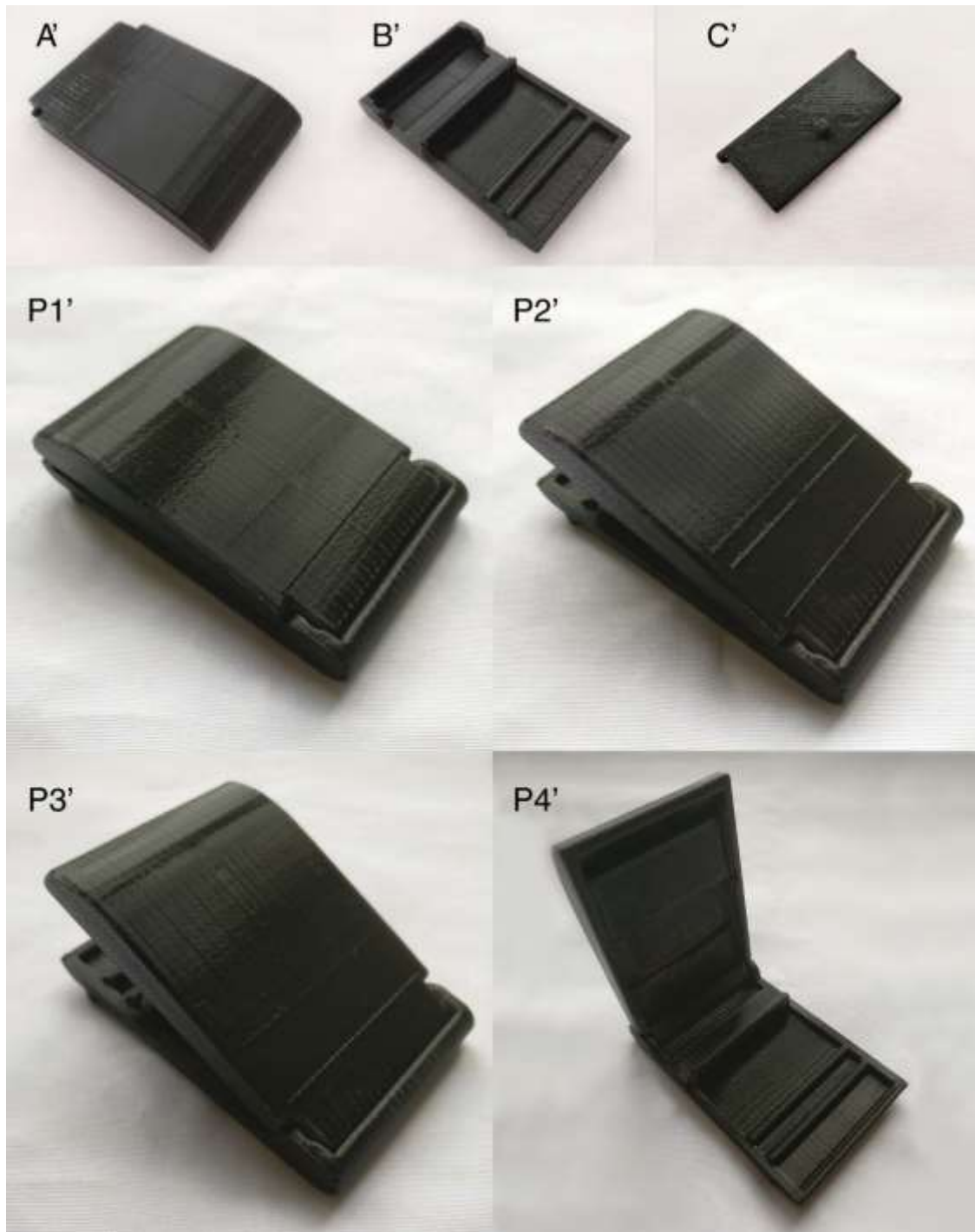




**Figure 86:** Final products, with all the parts assembled, representing all the possible configurations of the multifunctional stand and of the lapdesk.

### 3.2.5.2.3. Prototype

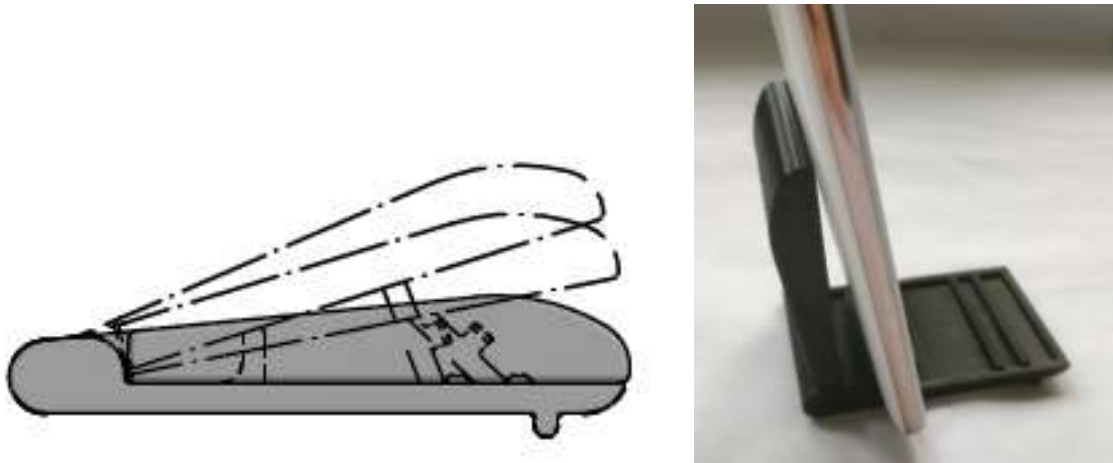
Following the same procedure as that of the first prototype of the multifunctional stand, the second prototype (Figure 87) was also made using a FDM 3D printer.



**Figure 87:** Second prototype, using a FDM 3D printer, of the three parts of the multifunctional stand and respective assembling with configurations *P1'*, *P2'*, *P3'* and *P4'*.

Regarding that specific modifications were introduced to solve the problems identified in the first prototype of the multifunctional stand, the testing of the second prototype was only focused on the problems that had emerged before. There is a big difference

in the height adjustability, which facilitates the placement of part C in the intended position and prevent the smartphone or tablet from toppling (Figure 88).



**Figure 88:** Testing of the second multifunctional stand prototype considering the problems identified in the first prototype.

However, despite being able to hold a smartphone, the stand cannot hold a tablet in a vertical position. This is due to the fact that the moment of the force being in the limit, since the smartphone almost topples, if it is in the vertical position (Figure 89).



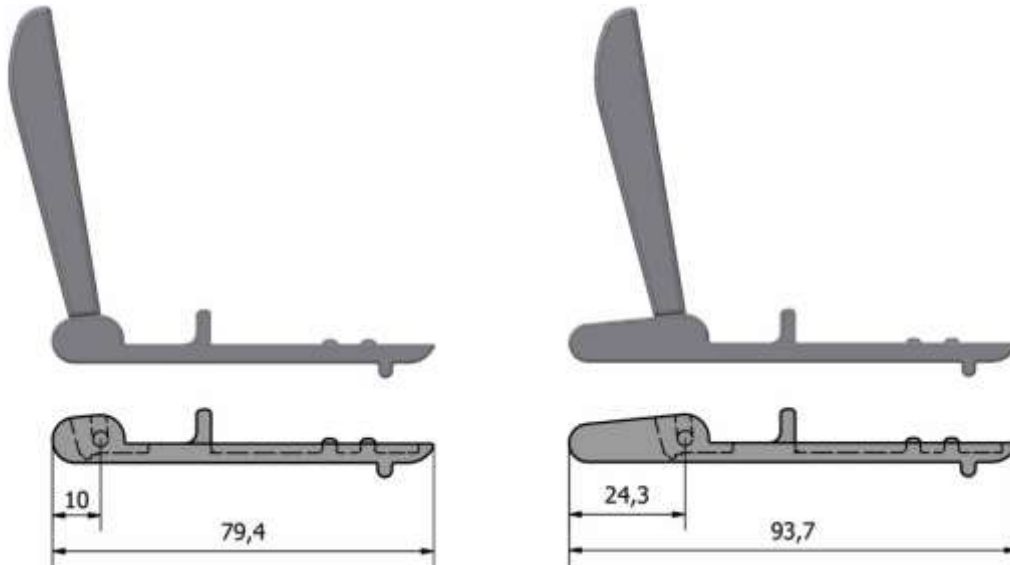
**Figure 89:** Applying a small force in the top of the smartphone, it will easily topple.

Despite the abovementioned drawback, part C gets successfully fixed in the expected position whenever the multifunctional stand is closed although it is hard to take it off its place since the room to place the finger to pull it may not be wide enough (Figure 90).



**Figure 90:** Representation of how part C gets fixed and trying to pull part C from the fixed position.

Taking these conclusions into consideration, a slight change on the multifunctional stand had to be introduced in order to cope with the toppling problem. Thus, extending the back of part *B* would probably solve that problem, as Figure 91 shows.



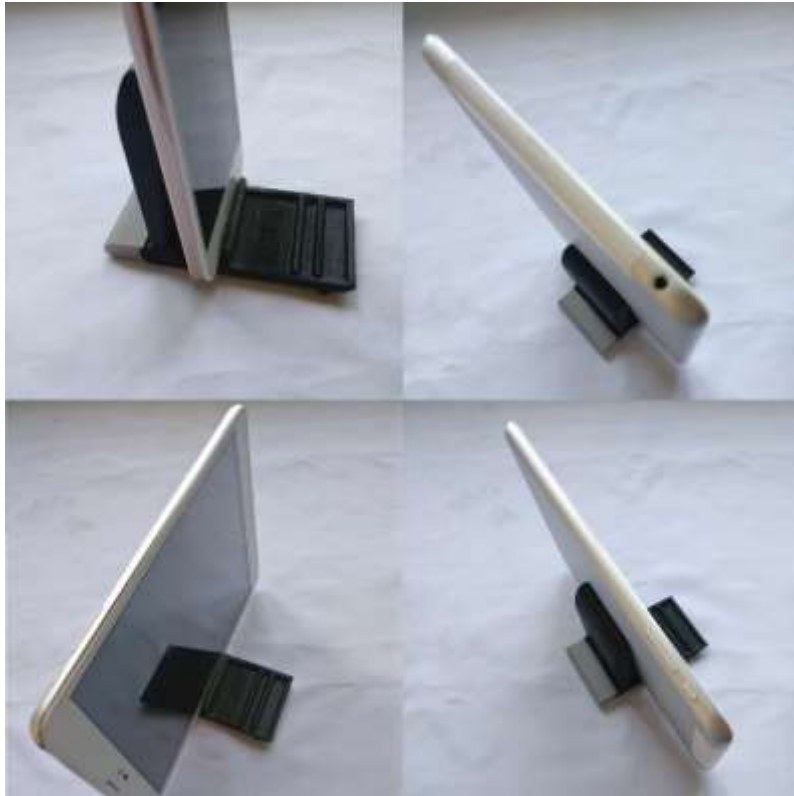
**Figure 91:** The multifunctional stand before and after being extended in the back of part *B*.

In order to avoid further prototyping costs, only a prototype of the intended size of the extending part was done and glued to part *B* (Figure 92). After the new model was ready, further testing was carried out using either a smartphone and a tablet, to check if it still topples or not (Figure 93).



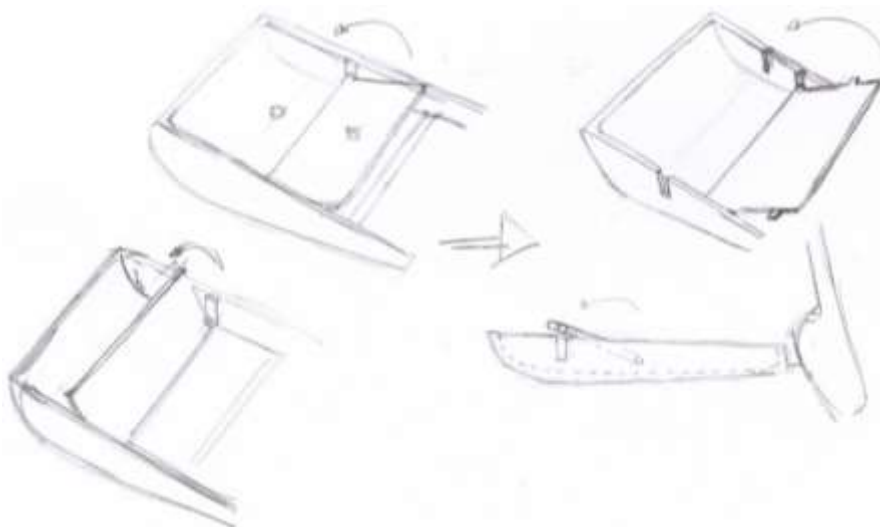
**Figure 92:** Above, 3D model and prototype of the extending part and below already glued to the multifunctional stand.

The testing of new model of the multifunctional stand proved successful, since neither the smartphone nor the tablet toppled, as Figure 93 shows.



**Figure 93:** Testing of the multifunctional stand with the extending part.

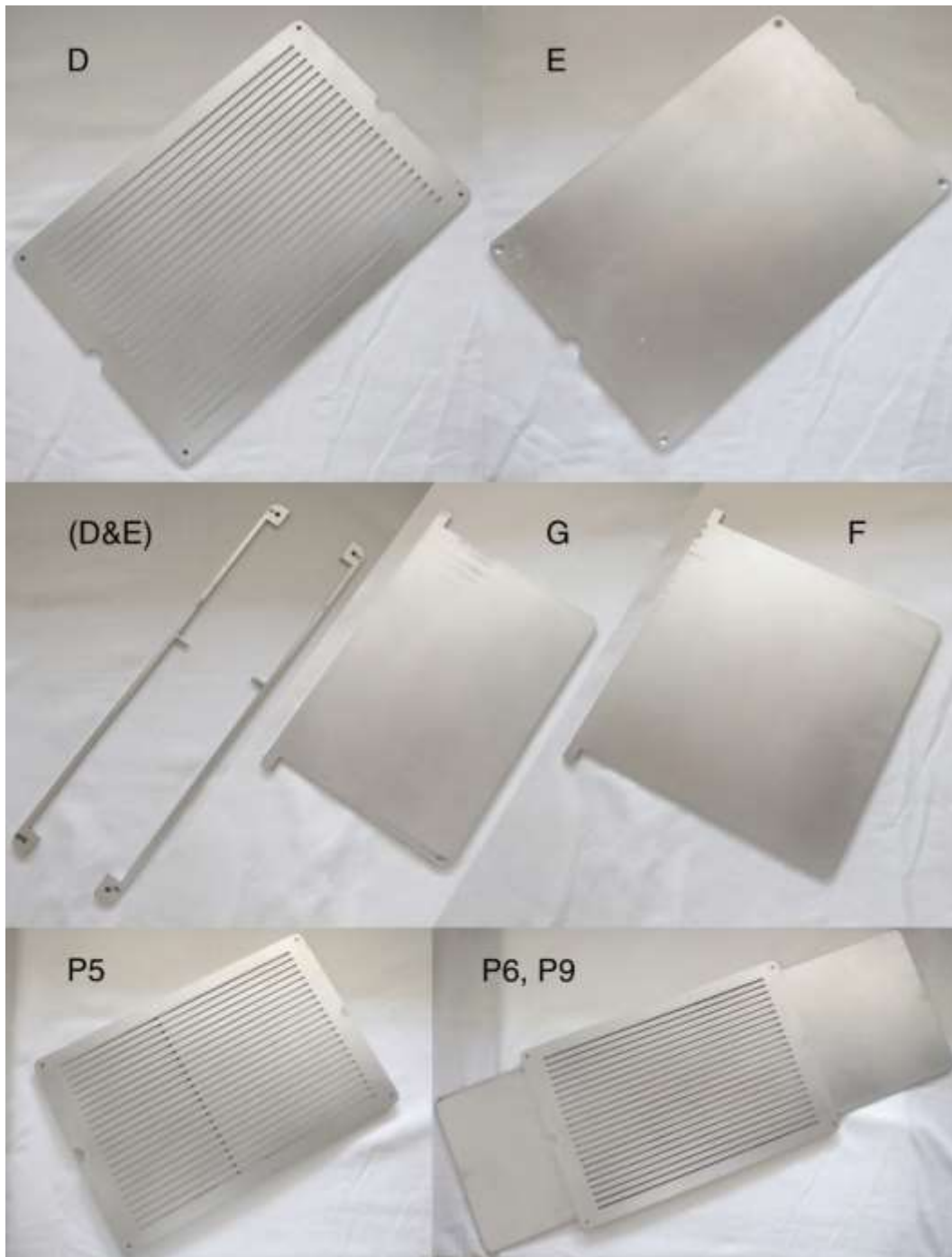
Bearing in mind the problem in the part C before identified, no modification in this work will be introduced, since it would require new prototypes, both for parts A and C. However, below a sketch with a suggestion of a modification that can eventually be studied on future work is presented (Figure 94). This modification would substitute the dowel in the part C and the hole in the part A by two gaps in the latter and two protrusions in part C to fit in. These two protrusions should be wider than the width of part A and part B in order to make it easier to pull part C when it is fixed.



**Figure 94:** Suggestion of a modification to easily pull part C when fixed in part A.

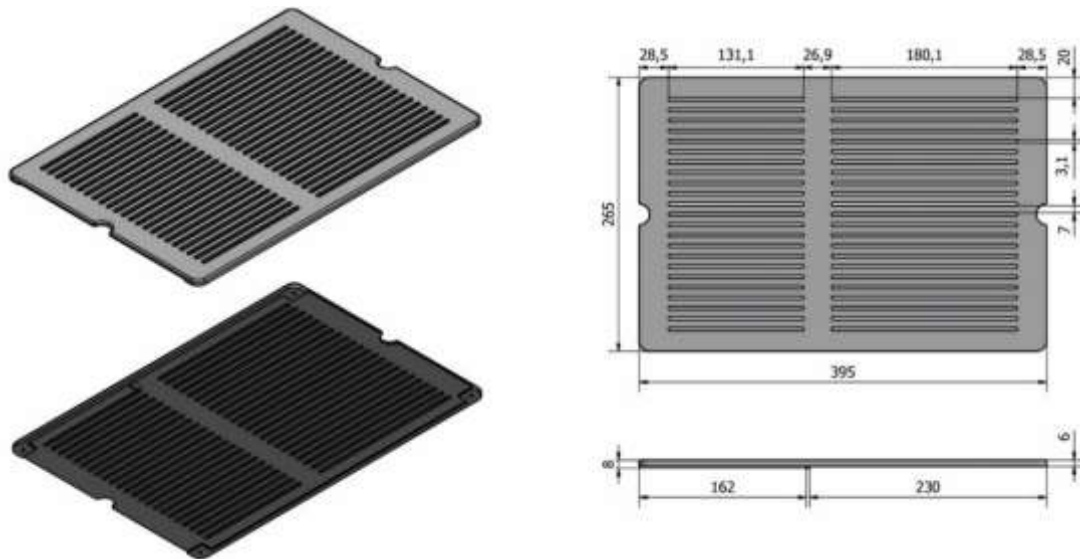


As far as the lapdesk prototype is concerned, the decision was to make the prototype using a laser cutting machine in an enterprise. Despite being aware that aluminium is ideally much lighter, the choice was to use iron to make the lapdesk prototype, mostly due to the difference in price. The next step was to create another two layers of the product so as to be able to cut all the parts from a 4mm thick iron plate. Figure 95 presents all the parts that have been cut by the laser cutting machine to create the prototype of the lapdesk. All the different parts were sprayed with cold galvanising to avoid oxidation and corrosion. Additionally, Figure 95 shows all the parts assembled by using four DIN7991 M5x10 screws.



**Figure 95:** Different parts obtained by using a laser cutting machine of the prototype of the lapdesk and respective assembly.

While handling the lapdesk prototype, it was possible to observe that it would be better if the slats were not so long. Taking this into consideration, Figure 96 presents a suggestion of a modification in part *D*, that will increase the strength of the slats, and which should be considered for future work.



**Figure 96:** Suggestion of a modification to increase the strength of the slats of part *D*.

Besides this, the prototype proved to be functional, so parts *F* and *G* are able to slide between parts *D* and *E*, and the multifunctional stand fits in the slats in order to get stuck while using the laptop on it, as Figure 97 shows.



**Figure 97:** Detail and images illustrating how the multifunctional stand fits and gets stuck in the slats.

However, as expected, this prototype does not have the exact dimensions as the 3D CAD model. Thus, the sliding movement of parts *F* and *G* is not so smooth and linear as it should be. Moreover, it is not possible to evaluate the strength of parts *F* and *G* when they are fully opened, since the material of the prototype is different from the intended material for production, which is the bio-composite referred in chapter 3.1.

Bearing in mind the matrix of needs of the benchmarking presented on page 108, it is possible to conclude that the product of the design proposal meets all the important features for a lapdesk, as shown below on Table 25.

Model \ Features	Height adjustability	Usability (lap)	Multifunctional	External mouse	Transport (easy)
Lapdesk and multifunctional stand (design proposal)	X	X	X	X	X

**Table 25:** Matrix of needs for the design proposal of a lapdesk and multifunctional stand.

From all that has been written in this chapter, it is considered that both prototypes, the multifunctional stand and lapdesk, were successfully produced and they are ready to go through product validation, as presented along the chapter that follows.

### 3.2.6. Product validation

As abovementioned, some usability tests in different environments and contexts will be described. The idea was asking someone to try the products with a smartphone, a tablet and a laptop in different environments such as in a bus, on train, in a café and at home. The opinions and suggestions of the user were registered and were as follows.

Moreover, it is important to refer that these usability tests should have been made with wider number of users and also several other possible environments, since there are many and different models of buses, trains, airplanes, tables, sofas, etc. which will, naturally, provide different user experiences.

- Transport

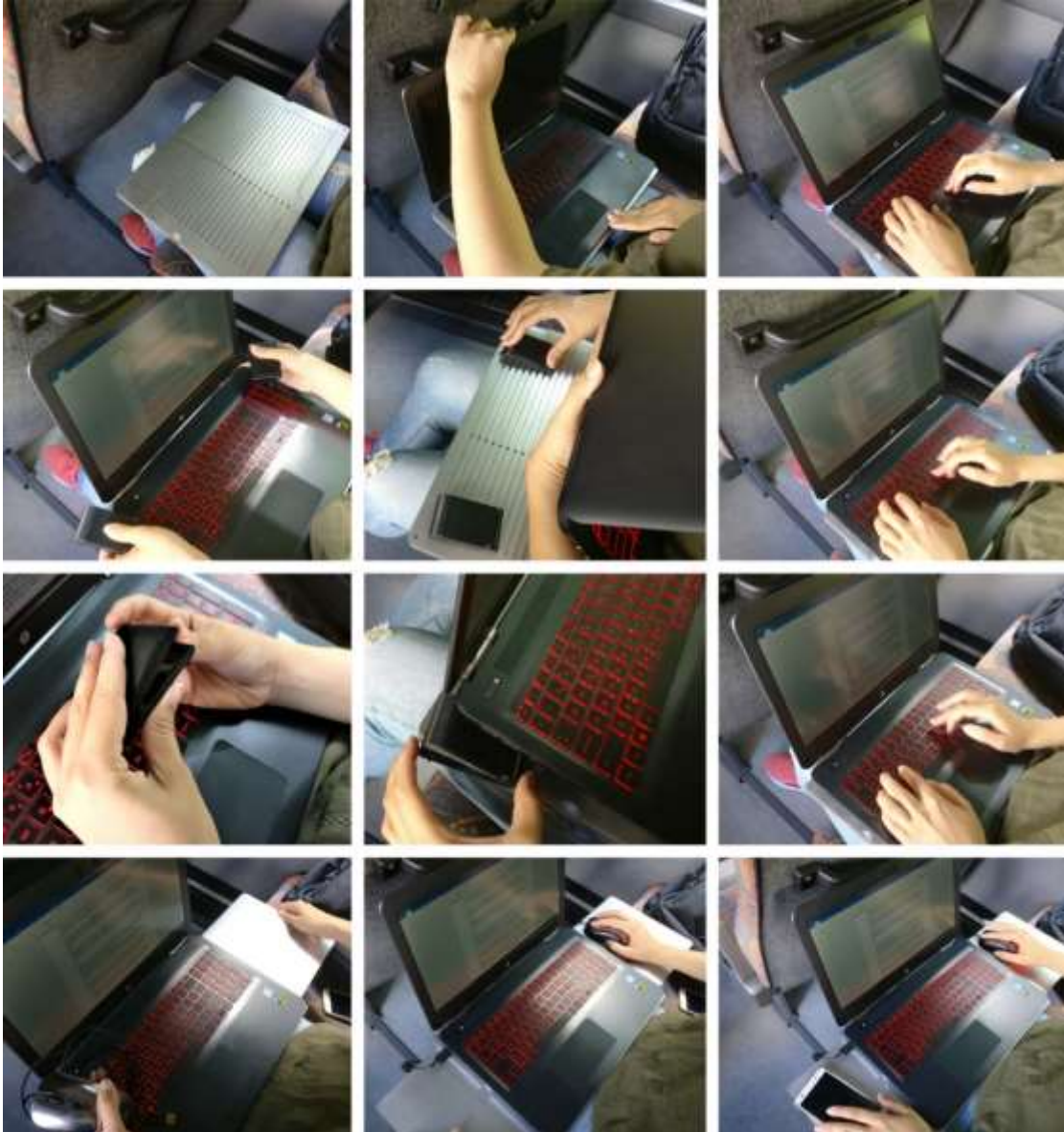
Despite the weight of the prototype of the lapdesk, it seemed interesting to check if it fitted in a laptop backpack. Considering the size of a 15.6in laptop backpack as shown in Figure 98, it was possible to observe that the lapdesk easily fitted in this backpack, which means that it is highly probable to fit in similar or bigger laptop backpacks.



**Figure 98:** Placing the prototype of the lapdesk in a 15.6in laptop backpack to check if it fits.

- In a bus

Taking into account the model of the bus, it was only possible to try the lapdesk with and without the multifunctional stand to place the laptop in order to work on it. Typing on the laptop while placed on the legs or placed on the lapdes, with and without the multifunctional stand and all possible configurations, was then tested. Using the mouse on the sliding surface, or part *F*, was also tested as shown in Figure 99.



**Figure 99:** The user testing to type on the laptop over the lapdesk with the possible configurations.

The user reported to have felt more comfortable and found it more to stable type on the laptop while using the lapdesk than without it. Regarding the use of the multifunctional stand to rise the back part of the laptop, the user reported to have felt more comfortable without using it, yet the lowest level of the stand was also acceptable. As far as the sliding surfaces are concerned, the user reported that they are very useful and, no doubt, the possibility of using the mouse becomes a plus. However, taking into consideration the seat of the user, it may become impossible to use the sliding surfaces in case another passenger is sitting next to the user due to the lack of space to do it.

- In a short-distance train

Unfortunately, this train is quite similar to the bus yet being wider, so with more space for passengers. Nevertheless, bearing in mind the space required to use the sliding surfaces, some tests were made to observe this situation, as shown below (Figure 100).



**Figure 100:** The user testing the sliding surface both for the mouse and to write on a book.

First of all, it was perceptible that, in this particular situation, the user had obviously more space available. Besides, taking into account the tests made in a bus, the user made these tests without the multifunctional stand. Thus, part *F* was used both for the mouse and writing on a notebook. The user reported, that just as in the bus, the sliding surfaces can become very useful while working on a laptop. Moreover, the seat of the user would allow to use the sliding surfaces even if someone was sitting next to her.

- On a table at a café

As aforementioned, the multifunctional stand can be used to hold either smartphones or tablets but, also to rise the back part of the laptop. It can be used together with the lapdesk or alone, if the user is working on a table. Taking this into consideration, the next decision implied using the multifunctional stand to rise the back part of the laptop while working on a table, as Figure 101 show.



**Figure 101:** Testing the multifunctional stand to rise the back part of the laptop while working on a table.

In this case, the user reported that using the stand provided more comfort while typing on the laptop. After testing all the different configurations, the ones in which the user felt higher comfort were with the multifunctional stand or level one in height. While using

the second level of height, the user reported that a bigger stress was put on the wrist. Yet, she considered that position could be interesting depending on what a person was doing in the laptop, such as, for example, watching a film, reading some document, etc. Moreover, the small size and weight of the product, made it very easy to transport.

- At home/office

As abovementioned, the multifunctional stand can also be used to hold smartphones or tablets. Regarding this, Figure 102 shows the user trying the multifunctional stand both with a smartphone and a tablet. The next step was the decision to try to use the prototype in two different environments: while working on a table and while sitting on the sofa. In addition, the laptop was also used with the multifunctional stand in a slight risen position while working on a table, which was a similar situation to that in the café.



**Figure 102:** User trying the multifunctional stand with a smartphone, table and laptop on a table and on a sofa.

As for the multifunctional stand used on the table, this experiment was very similar to the one that had happened in the café. Yet, as for the use of the multifunctional stand

for the smartphone, the user transmitted positive signs while using it but reported that there could be an added value if could be used in more than simply one inclination possibility as suggested in Figure 102. However, it may be really interesting to be able to use both, smartphone and/or tablet and laptop, at the same time since nowadays more and more people, for some reason, seem to be very dependent on these equipment.

Regarding the use of the multifunctional stand, with the tablet, on the sofa, the user reported that it can be a very useful tool while having some leisure such as, for example, watching a movie. Besides its usefulness for the purpose described above, it also proves useful while traveling by bus, by train or by plane.

From all that has been written before, it is possible to conclude that both products have some space for improvement mostly because they are undoubtedly useful, functional, effective and user-friendly. Thus, study a new or different level of inclination for the smartphones or tablets as well as placing some rubbers in strategic points to avoid slipping should be considered. Moreover, the conclusions at chapter 3.2.5.2.3 should also be considered. Finally, and bearing in mind that these products can be produced by an injection molding process, the losses defined in the 3D model and all the parts must be evaluated by a polymer injection specialist before proceeding to the manufacturing of the injection mold.

### 3.2.7. Renders

Along this chapter renders of both products, multifunctional stand and lapdesk, will be presented. As far as the aesthetics of the products is concerned and as aforementioned in chapter 843.1.2.3, experiment 2 from phase 2 of the experimental work was unequivocally the most appealing. Thus, taking this into consideration, an image with the texture of the resulting bio-composite to apply in the products by using *Keyshot*, a renderization software, is shown below in Figure 103.



**Figure 103:** Texture applied in the designed products.

- Multifunctional stand

Below, a series of renders regarding the multifunctional stand and several possible configurations as presented on Figure 104.

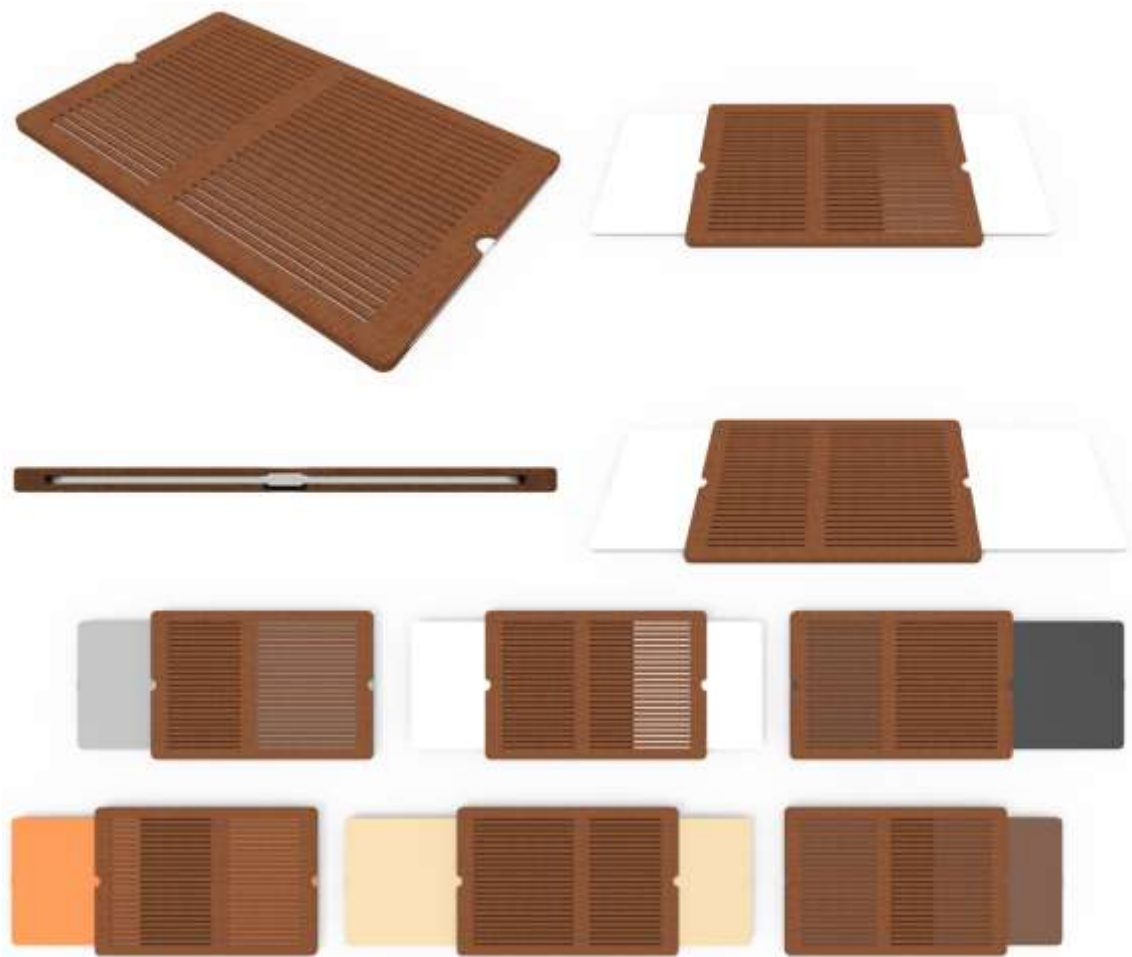


**Figure 104:** Renders of the different configurations of the multifunctional stand.



- Lapdesk

Figure 105 presents a series of renders regarding the lapdesk and the possible configurations. In this particular case, it was decided to use neat PLA with different colours on parts *F* and *G*, which are shown below but not limited to those. It is expected that this product can have more impact on consumers according to their emotions.



**Figure 105:** Renders of the different configurations of the lapdesk, as well as different colours for parts *F* and *G*.

- In context of use

Figure 106 presents a series of renders of both products, the multifunctional stand and the lapdesk, in context of use.



**Figure 106:** Multifunctional stand and lapdesk in different contexts of use.

## 4. Conclusion



## 4.1. Generic conclusion

As part of the set objectives for this research, by using grinded and/or milled almond nuts waste as a reinforcement, which could also be named as a bio-filler, in a matrix of PLA, a new environment friendly bio-composite was developed and studied.

According to the information presented on chapter 1.2, there is a need to find new environment friendly solutions and to adopt new lifestyles, and among other reasons, one of the most important is to expect a better future for planet Earth. As Roszak (1992) wrote in his book, *The voice of the Earth*, “if psychosis is the attempt to live a lie, our psychosis is the lie of believing we have no ethical obligation to our planetary home”. Bearing this in mind and taking into account that plastic provides unique and innumerable properties for manufacturers, there is the urge to stop the high rate of production and consumerism of oil-based plastics, since our dependence on it leads to concerns in terms of economic and environmental sustainability. Thus, according to the literature review, the use of bio-based plastic has been growing and proves to be capable of replacing oil-based plastic. Moreover, new materials can still be developed, mainly with the blending of several other materials to create new composites. From this point of view, incorporation of natural waste in thermoplastics proves to have increasing interest and a growing number of applications due to its properties. Besides, literature review showed that there are already many enterprises using natural waste for product design, as shown in chapter 2.4.

In the book *Design for Sustainability: A Practical Approach* (2007), a quote from Mackenzie says: “Designers can make a significant difference to the effect of a product because they are responsible for influencing the key decisions”. From this point of view, this dissertation and research focused on the development of a new bio-composite by mixing two materials from natural resources, so environment friendly: almonds nuts waste and PLA. The results in terms of aesthetics and texture were undeniably positive, but the material characterization is required to know the properties of the material yet through literature review it is expected promising results. Moreover, there is still space for different blends using these materials and, also for additives, which could improve some properties of the final composite.

Bearing this in mind, after concluding the material development, a new product was designed to apply the material. Thus, after problem definition, ideation and benchmarking, a multifunctional stand for smartphones, tablets and laptops, and a lapdesk to place the laptop while working on it were developed, as well as real scale prototypes. These prototypes were submitted to user experience tests and the results were positive, yet with some indications for improvement.

In short, the realization of this dissertation allowed to conclude that almond by-products may have a potential use in the creation of new bio-composites. Bearing in mind the problem related to the high production and consumerism of oil-based polymers, the production and consumerism of bio-composites will reduce the need of using more polluting polymers, thus reducing the negative impact that the human being causes on Earth. In addition, the continuous exploitation of other renewable resources, namely resulting from industrial waste, should go further in order to develop new bio-

composites. Taking this into account and as aforementioned, it is expected that oil-based polymers and composites will be fully replaced by bio-based polymers or bio-composites in order to avoid the pollution of the Earth.

Finally, during this dissertation, the full paper *Valorisation of different wastes: a sustainable approach in the design of new products* (Appendix V) was written together with, Doctor Jorge Lino Alves, Doctor Bárbara Rangel, Daniela Monteiro, Ruben Ribeiro and Vasco Canavarro for the *4<sup>th</sup> International Conference on Wastes: Solutions, Treatments and Opportunities*. This paper has already been accepted and will be included in the book published by *CRC Press – Taylor & Francis Group*, that will be proposed to *Scopus and Thomson Reuters* for indexing. The presentation of the paper, will be held in Porto on 25<sup>th</sup> and 26<sup>th</sup> of September of 2017.

## 4.2. Study limitations

The research of this dissertation was quite limited in some moments. Thus, as aforementioned, during the experimental process, some equipment would be necessary to perform some experiments more accurately and to provide more valuable scientific data, as well as by following some standards. Additionally, due to the expensive costs of some manufacturing processes, the lapdesk had to be made in iron using a laser cutting machine instead of, for example, the FDM 3D printing process as for the multifunctional stand.

## 4.3. Future work

From all that has been written before, there is some work to be done in the future. Firstly, as far as the bio-composite developed on this dissertation is concerned, a full material characterization should be made in order to know it and check if it is viable and safe to use it in the production of new products. The addition of different organic waste or additives should also be considered for a new material or even to improve this bio-composite. Moreover, a cost analysis to produce the bio-composite should be made in order to know if it is economically viable for manufacturers, as well as make a LCA.

Secondly, bearing in mind the analysis and user experience of the prototypes, some modifications should be made in order to meet the expectations of the consumers. Thus, parts A and C of the multifunctional stand should be redesigned to more easily pull and handle part C. If necessary, part B must be modified. Moreover, the inclination angle for the smartphones or tablets should be increased and/or one more level of inclination created, thus giving one more option for the user. The inclusion of some rubbers in specific places can be evaluated in order to avoid slipping of the equipment. As far as the lapdesk is concerned, a FDM 3D printing prototype should be considered to obtain a product more similar to the 3D model. Besides, the heat ventilation capacity of the lapdesk should be studied and, if necessary, design some slats in part E. Additionally, both products should be tested with a wider number of users to obtain more opinions as well as both products designs should be analyzed by an injection polymers specialist before producing the injection molds to produce the products.

Lastly, it is intended to participate and write a paper for the 2<sup>nd</sup> Internacional Conference on Materials Design and Applications 2018 to be held at FEUP, in Porto.





## 5. References



- Actto. "NLD-01". Accessed 07/03/2017. [http://www.actto.com/shop/product\\_detail.asp?cate=notebook&code=NLD-01](http://www.actto.com/shop/product_detail.asp?cate=notebook&code=NLD-01).
- Aidata. "LD007 / LD007P Lapboard". Accessed 08/03/2017. <http://www.aidata.com/page/94>.
- Aktas, T., P. Thy, R. B. Williams, Z. McCaffrey, R. Khatami, and B. M. Jenkins. 2015. "Characterization of almond processing residues from the Central Valley of California for thermal conversion." *Fuel Processing Technology* no. 140:132-147. <http://www.sciencedirect.com/science/article/pii/S0378382015301417>.
- Álvarez-Chávez, Clara Rosalía, Sally Edwards, Rafael Moure-Eraso, and Kenneth Geiser. 2012. "Sustainability of bio-based plastics: general comparative analysis and recommendations for improvement." *Journal of Cleaner Production* no. 23 (1):47-56. <http://www.sciencedirect.com/science/article/pii/S095965261100374X>.
- Ananas Anam. "Pinatex TM". Accessed 08/12/2016. <http://www.ananas-anam.com/>.
- Asundi, Krishna, Dan Odell, Adam Luce, and Jack T. Dennerlein. 2012. "Changes in posture through the use of simple inclines with notebook computers placed on a standard desk." *Applied Ergonomics* no. 43 (2):400-407. <http://www.sciencedirect.com/science/article/pii/S000368701100086X>.
- Ayrimis, Nadir, Alperen Kaymakci, and Ferhat Ozdemir. 2013. "Physical, mechanical, and thermal properties of polypropylene composites filled with walnut shell flour." *Journal of Industrial and Engineering Chemistry* no. 19 (3):908-914. <http://www.sciencedirect.com/science/article/pii/S1226086X12003723>.
- Bakker Elkhuizen. "ErgoTraveller". Accessed 17/02/2017. <https://www.bakkerelkhuisen.com/knowledge-center/ergotraveller-creates-a-comfortable-workplace-for-travelling-laptop-users/>.
- . "UltraStand". Accessed 17/02/2017. <https://www.bakkerelkhuisen.com/notebook-stands/ultrastand/>.
- Bhamra, Tracy, and Vicky Lofthouse. 2007. *Design for Sustainability : A Practical Approach*, Design for Social Responsibility Series. Aldershot: Gower.
- Biotrem. 2017. Accessed 28/05/2017. [www.biotrem.pl/en/](http://www.biotrem.pl/en/).
- Biron, Michel. 2013. "1 - Outline of the Actual Situation of Plastics Compared to Conventional Materials." In *Thermoplastics and Thermoplastic Composites (Second Edition)*, 1-29. William Andrew Publishing. <http://www.sciencedirect.com/science/article/pii/B9781455778980000019>.
- Brandes, Uta, Miriam Wender, and Sonja Stich. 2013. *Design by Use : The Everyday Metamorphosis of Things*. Basel: Birkhäuser.
- Caballero, J. A., R. Font, and A. Marcilla. 1996. "Comparative study of the pyrolysis of almond shells and their fractions, holocellulose and lignin. Product yields and kinetics." *Thermochemica Acta* no. 276:57-77. <http://www.sciencedirect.com/science/article/pii/0040603195027947>.
- California Almonds. "Almond Lifecycle". Accessed 28/08/2016. <http://www.almonds.com/food-professionals?mobile=1>.
- Cather, Harry, Richard Morris, Mathew Philip, and Chris Rose. 2001. *Design Engineering*. Oxford: Newnes.
- Central Intelligence Agency. 2016. "The World Factbook: World". Last modified 11/07/2016. Accessed 31/07/2016. <https://www.cia.gov/library/publications/the-world-factbook/geos/xx.html>.
- Chiou, Bor-Sen, Diana Valenzuela-Medina, Cristina Bilbao-Sainz, Artur P. Klamczynski, Roberto J. Avena-Bustillos, Rebecca R. Milczarek, Wen-Xian Du, Greg M. Glenn, and William J. Orts. 2016. "Torrefaction of almond shells: Effects of torrefaction conditions on properties of solid and condensate products." *Industrial Crops and Products* no. 86:40-48. <http://www.sciencedirect.com/science/article/pii/S0926669016301765>.
- Design Council. 2015. "Our story 1945-2015". Accessed 13/08/2016. <http://www.designcouncil.org.uk/our-story-1>.

- Diário de Notícias. 2016. "Já esgotámos o orçamento anual dos recursos renováveis da Terra". Last modified 08/08/2016. Accessed 13/08/2016. <http://www.dn.pt/sociedade/interior/esgotamos-hoje-o-orcamento-anual-dos-recursos-renovaveis-da-terra-5327999.html>.
- Ecovative Design. "How It Works". Accessed 10/12/2016. <http://www.ecovatedesign.com/how-it-works>.
- . "MycoBoard". Accessed 11/12/2016. <http://www.ecovatedesign.com/myco-board>.
- . "MycoFoam". Accessed 11/12/2016. <http://www.ecovatedesign.com/myco-foam>.
- . "We Grow Materials". Accessed 10/12/2016. <http://www.ecovatedesign.com/home>.
- Elvin, George. 2015. *Post-Petroleum Design*: Routledge.
- Energy research Centre of the Netherlands - Phyllis2. 2002. "almond shells (#2314)". Last modified 26/08/2002. Accessed 13/04/2017. <https://www.ecn.nl/phyllis2/Biomass/View/2314>.
- Esfahlan, Ali Jahanban, Rashid Jamei, and Rana Jahanban Esfahlan. 2010. "The importance of almond (*Prunus amygdalus* L.) and its by-products." *Food Chemistry* no. 120 (2):349-360. <http://www.sciencedirect.com/science/article/pii/S0308814609011236>.
- Essabir, H., S. Nekhlaoui, M. Malha, M. O. Bensalah, F. Z. Arrakhiz, A. Qaiss, and R. Bouhfid. 2013. "Bio-composites based on polypropylene reinforced with Almond Shells particles: Mechanical and thermal properties." *Materials & Design* no. 51:225-230. <http://www.sciencedirect.com/science/article/pii/S0261306913003464>.
- Essabir, Hamid, Mohammed Ouadi Bensalah, Denis Rodrigue, Rachid Bouhfid, and Abou el kacem Qaiss. 2016. "Biocomposites based on Argan nut shell and a polymer matrix: Effect of filler content and coupling agent." *Carbohydrate Polymers* no. 143:70-83. <http://www.sciencedirect.com/science/article/pii/S014486171630042X>.
- Eu Como Sim. "Faça em casa: farinha de amêndoas e a receita do Financier". Accessed 28/06/2017. <http://www.eucomosim.com/receitas/receita-farinha-de-amedoas-e-financier/>.
- European Commission. 2015. "Development of guidance on Extended Producer Responsibility (EPR)". Last modified 17/08/2015. Accessed 07/08/2016. [http://ec.europa.eu/environment/archives/waste/eu\\_guidance/introduction.html](http://ec.europa.eu/environment/archives/waste/eu_guidance/introduction.html).
- EUROPEN. "Food Waste". Accessed 07/08/2016. <http://www.europen-packaging.eu/policy/7-food-waste.html>.
- FAOSTAT. Accessed 28/08/2016. <http://faostat3.fao.org/browse/Q/QC/E>.
- Fernandes, Emanuel M., Vitor M. Correlo, João F. Mano, and Rui L. Reis. 2015. "Cork-polymer biocomposites: Mechanical, structural and thermal properties." *Materials & Design* no. 82:282-289. <http://www.sciencedirect.com/science/article/pii/S0261306915002939>.
- Future Power. "Vipot". Accessed 11/12/2016. <http://www.futurepowersrl.eu/>.
- Gold, J. E., J. B. Driban, V. R. Yingling, and E. Komaroff. 2012. "Characterization of posture and comfort in laptop users in non-desk settings." *Applied Ergonomics* no. 43 (2):392-399. <http://www.sciencedirect.com/science/article/pii/S0003687011000871>.
- González, J. F., J. Gañán, A. Ramiro, C. M. González-García, J. M. Encinar, E. Sabio, and S. Román. 2006. "Almond residues gasification plant for generation of electric power. Preliminary study." *Fuel Processing Technology* no. 87 (2):149-155. <http://www.sciencedirect.com/science/article/pii/S0378382005001608>.
- González, Juan F., Carmen M. González-García, Antonio Ramiro, José Gañán, Jerónimo González, Eduardo Sabio, Silvia Román, and Joao Turegano. 2005. "Use of almond residues for domestic heating. Study of the combustion parameters in a mural boiler." *Fuel Processing Technology* no. 86 (12-13):1351-1368. <http://www.sciencedirect.com/science/article/pii/S0378382005000494>.
- Gorp, Trevor van, and Edie Adams. 2012. *Design for Emotions*: Morgan Kaufman.
- Green & Associates. "About". Accessed 11/12/2016. <http://www.ganda.org/>.
- . "OOObject - About". Accessed 11/12/2016. <http://www.oobject.com/about.html>.

- . "OOObject - Hloopy". Accessed 11/12/2016. <http://www.oobject.com/hloopy.html>.
- . "OOObject - Nook". Accessed 11/12/2016. <http://www.oobject.com/nook.html>.
- . "OOObject - Yock". Accessed 11/12/2016. <http://www.oobject.com/yock.html>.
- Gunlocke. Savor. editado por Savor Guest Seating: Gunlocke. [http://www.gunlocke.com/public\\_html/products/guest/savor.html#](http://www.gunlocke.com/public_html/products/guest/savor.html#).
- Hebel, Dirk E., Marta H. Wisniewska, and Felix Heisel. 2014. *Building from Waste*. Basel/Berlin/Boston, AT: Birkhäuser.
- Heskett, John. 2005. *Design : A Very Short Introduction*, Very Short Introductions. Oxford: Oxford University Press.
- Hilltop Ranch. "Huller/Sheller Plant". Accessed 30/06/2017. <https://hilltopranch.com/our-plant/hullersheller-plant/>.
- Hottle, Troy A., Melissa M. Bilec, and Amy E. Landis. 2013. "Sustainability assessments of bio-based polymers." *Polymer Degradation and Stability* no. 98 (9):1898-1907. <http://www.sciencedirect.com/science/article/pii/S0141391013001870>.
- Houston, Katherine. 2016. "Can agricultural waste become an everyday accessory?". Last modified 29/01/2016. Accessed 01/12/2016. <http://www.designcurial.com/news/can-agricultural-waste-become-an-everyday-accessory-4797465>.
- Husque. "Made with macadamia nut shell". Accessed 01/12/2016. <http://www.husque.com/husque.html>.
- Industrial Designers Society of America. "What is Industrial Design?". Accessed 09/08/2016. <http://www.idsa.org/education/what-is-industrial-design#field--how-they-do-it-2>.
- International Nut and Dried Fruit Council Foundation. 2015. *Global Statistical Review 2014-2015*. INC. [www.nutfruit.org](http://www.nutfruit.org).
- iSkelter. "Comfy Lite". Accessed 08/03/2017. <http://iskelter.com/product/comfy-lite-lapdesk/>.
- . "Comfy Pad LapDesk". Accessed 08/03/2017. <http://iskelter.com/product/comfy-pad-lap-desk/>.
- . "Hover X LapDesk". Accessed 08/03/2017. <http://iskelter.com/product/hover-x-ultimate-gamers-lapdesk/>.
- Jahan, A., M. Y. Ismail, S. M. Sapuan, and F. Mustapha. 2010. "Material screening and choosing methods – A review." *Materials & Design* no. 31 (2):696-705. <http://www.sciencedirect.com/science/article/pii/S0261306909004361>.
- Jose Borrell S.A. Accessed 24/08/2016. <http://jborrell.com/>.
- Karana, Elvin. 2012. "Characterization of 'natural' and 'high-quality' materials to improve perception of bio-plastics." *Journal of Cleaner Production* no. 37:316-325. <http://www.sciencedirect.com/science/article/pii/S0959652612003721>.
- Karana, Elvin, Paul Hekkert, and Prabhu Kandachar. 2009. "Meanings of materials through sensorial properties and manufacturing processes." *Materials & Design* no. 30 (7):2778-2784. <http://www.sciencedirect.com/science/article/pii/S0261306908004883>.
- . 2010. "A tool for meaning driven materials selection." *Materials & Design* no. 31 (6):2932-2941. <http://www.sciencedirect.com/science/article/pii/S0261306909007110>.
- Kolstad, Jeffrey J., Erwin T. H. Vink, Bruno De Wilde, and Lies Debeer. 2012. "Assessment of anaerobic degradation of Ingeo™ polylactides under accelerated landfill conditions." *Polymer Degradation and Stability* no. 97 (7):1131-1141. <http://www.sciencedirect.com/science/article/pii/S0141391012001413>.
- Krzan, Andrej, Sarunya Hemjinda, Stanislav Miertus, Andrea Corti, and Emo Chiellini. 2006. "Standardization and certification in the area of environmentally degradable plastics." *Polymer Degradation and Stability* no. 91 (12):2819-2833. <http://www.sciencedirect.com/science/article/pii/S0141391006001996>.
- LapGear®. "Deluxe Laptop LapDesk™ - 91475, Espresso". Accessed 08/03/2017. <http://www.lapdesk.com/deluxe-laptop-lapdesk-91475-espresso/>.

- Ledbetter, C. A. 2008. "Shell cracking strength in almond (*Prunus dulcis* [Mill.] D.A. Webb.) and its implication in uses as a value-added product." *Bioresource Technology* no. 99 (13):5567-5573.  
<http://www.sciencedirect.com/science/article/pii/S0960852407009224>.
- Lemberona. "Organic Wild Almond Skin Powder FAIRTRADE". Accessed 28/06/2017.  
<http://www.lemberona.com/products/ingredients/organic-wild-almond-skin-powder-fairtrade/>.
- Logitech. "Comfort Lapdesk N500". Accessed 05/03/2017.  
[http://support.logitech.com/en\\_us/product/comfort-lapdesk-n500](http://support.logitech.com/en_us/product/comfort-lapdesk-n500).
- . "Portable Lapdesk N315". Accessed 04/03/2017.  
[http://support.logitech.com/en\\_us/product/portable-lapdesk-n315](http://support.logitech.com/en_us/product/portable-lapdesk-n315).
- Macrae, Fiona. 2010. "How the heat from a laptop can 'toast' the skin on your thighs". Last modified 07/10/2010. Accessed 06/03/2017. <http://www.dailymail.co.uk/news/article-1317532/Laptop-heat-toast-skin-thighs.html>.
- Mallick, P. K. 2007. *Fiber-Reinforced Composites: Materials, Manufacturing and Design*. 3rd ed, Dekker Mechanical Engineering: CRC Press.
- MATREC SRL. 2015. *MADE IN FOOD WASTE - Food waste as sustainable resources*. MATREC SRL. Accessed 01/12/2016.
- Moffet, H., M. Hagberg, E. Hansson-Risberg, and L. Karlqvist. 2002. "Influence of laptop computer design and working position on physical exposure variables." *Clinical Biomechanics* no. 17 (5):368-375.  
<http://www.sciencedirect.com/science/article/pii/S0021929002000623>.
- Morlin-Yron, Sophie. 2016. "'Magic' mushroom material grows into desks, chairs and lampshades". Last modified 16/09/2016. Accessed 01/12/2016.  
<http://edition.cnn.com/2016/09/16/world/ecovative-mushroom-furniture/>.
- NaturePlast. 2016a. "The advantages of bioplastics". Accessed 08/04/2016.  
<http://www.natureplast.eu/en/bioplastics/interest-of-bioplastics/the-advantages-of-bioplastics.html>.
- . 2016b. "Applications". Accessed 08/04/2016.  
<http://www.natureplast.eu/en/bioplastics/applications.html>.
- . 2016c. "Bioplastics". Accessed 08/04/2016.  
<http://www.natureplast.eu/en/bioplastics/definitions.html>.
- . 2016d. "Comparative". Accessed 08/04/2016.  
<http://www.natureplast.eu/en/bioplastics/definitions/comparative.html>.
- NatureWorks LLC. 2016a. "About NatureWorks". Accessed 11/09/2016.  
<http://www.natureworkslc.com/About-NatureWorks>.
- . 2016b. "Composting". Accessed 13/04/2016. <http://www.natureworkslc.com/The-Ingeo-Journey/End-of-Life-Options/Composting>.
- . 2016c. "Eco-Profile". Accessed 08/04/2016. <http://www.natureworkslc.com/The-Ingeo-Journey/Eco-Profile-and-LCA/Eco-Profile>.
- . 2016d. "End-of-Life Road Map". Accessed 05/05/2016.  
<http://www.natureworkslc.com/Data/Flash-Items/EOL-Flash.aspx>.
- . 2016e. "Feedstock Certification Options for Ingeo". Accessed 16/10/2016.  
<http://www.natureworkslc.com/The-Ingeo-Journey/Raw-Materials/Feedstock-Certifications>.
- . 2016f. "Feedstock Recycling". Accessed 06/05/2016.  
<http://www.natureworkslc.com/The-Ingeo-Journey/End-of-Life-Options/Feedstock-Recycling>.
- . 2016g. "Glossary for Eco-Profile & LCA". Accessed 09/11/2016.  
<http://www.natureworkslc.com/The-Ingeo-Journey/Eco-Profile-and-LCA/Glossary#LCI>.

- . 2016h. "How is Ingeo made". Accessed 08/04/2016. <http://www.natureworkslc.com/The-Ingeo-Journey/Eco-Profile-and-LCA/How-Ingeo-is-Made>.
- . 2016i. "Incineration". Accessed 13/04/2016. <http://www.natureworkslc.com/The-Ingeo-Journey/End-of-Life-Options/Incineration>.
- . 2016j. "Ingeo™ 3251D". Accessed 08/04/2016. <http://catalog.ides.com/Datasheet.aspx?I=26793&E=124421>.
- . 2016k. "Landfill". Accessed 13/04/2016. <http://www.natureworkslc.com/The-Ingeo-Journey/End-of-Life-Options/Landfill>.
- . 2016l. "Product & Applications". Accessed 05/05/2016. <http://www.natureworkslc.com/Product-and-Applications>.
- . 2016m. "Recycling (recovery & sortation)". Accessed 13/04/2016. <http://www.natureworkslc.com/The-Ingeo-Journey/End-of-Life-Options/Recycling>.
- Niaounakis, Michael. 2013a. "1 - Introduction to Biopolymers." In *Biopolymers Reuse, Recycling, and Disposal*, 1-75. Oxford: William Andrew Publishing. <http://www.sciencedirect.com/science/article/pii/B9781455731459000014>.
- . 2013b. *Biopolymers Reuse, Recycling, and Disposal*. Oxford: William Andrew Publishing.
- . 2015a. *Biopolymers: Processing and Products*. Oxford: William Andrew Publishing.
- . 2015b. "Chapter 1 - Introduction." In *Biopolymers: Processing and Products*, 1-77. Oxford: William Andrew Publishing. <http://www.sciencedirect.com/science/article/pii/B9780323266987000015>.
- Nuts. "Raw Almonds (In Shell)". Accessed 30/06/2017. <https://nuts.com/nuts/almonds/raw-in-shell.html>.
- Oxford Learner's Dictionaries. 2016. "Definition of granola noun". Accessed 26/11/2016. [http://www.oxfordlearnersdictionaries.com/definition/english/granola\\_1?q=granola](http://www.oxfordlearnersdictionaries.com/definition/english/granola_1?q=granola).
- Panero, Julios, and Martin Zelnik. 2013. *Dimensionamento humano para espaços interiores. Um livro de consulta e referência para projetos*: Gustavo Gili.
- Papanek, Victor. 1995. *Arquitetura e Design - Ecologia e Ética*: Edições 70.
- Peneda, Constança, and Rui Frazão. 1995. *Ecodesign no Desenvolvimento dos Produtos*. 75 p. vols, Cadernos do INETI.
- Philp, J. C., R. J. Ritchie, and K. Guy. 2013. "Biobased plastics in a bioeconomy." *Trends in Biotechnology* no. 31 (2):65-67. <http://www.sciencedirect.com/science/article/pii/S0167779912002041>.
- Philp, Jim C., Alexandre Bartsev, Rachael J. Ritchie, Marie-Ange Baucher, and K. Guy. 2013. "Bioplastics science from a policy vantage point." *New Biotechnology* no. 30 (6):635-646. <http://www.sciencedirect.com/science/article/pii/S1871678412008783>.
- Pirayesh, Hamidreza, and Abolghasem Khazaeian. 2012. "Using almond (*Prunus amygdalus* L.) shell as a bio-waste resource in wood based composite." *Composites Part B: Engineering* no. 43 (3):1475-1479. <http://www.sciencedirect.com/science/article/pii/S1359836811002691>.
- PlasticsEurope. 2014. *Plastics – the Facts 2014/2015*. <http://www.plasticseurope.org>.
- Poli, C. 2001. *Design for Manufacturing : A Structured Approach*. Boston: Butterworth-Heinemann.
- Ramalhete, P. S., A. M. R. Senos, and C. Aguiar. 2010. "Digital tools for material selection in product design." *Materials & Design* no. 31 (5):2275-2287. <http://www.sciencedirect.com/science/article/pii/S0261306909007031>.
- Reddy, Murali M., Singaravelu Vivekanandhan, Manjusri Misra, Sujata K. Bhatia, and Amar K. Mohanty. 2013. "Biobased plastics and bionanocomposites: Current status and future opportunities." *Progress in Polymer Science* no. 38 (10–11):1653-1689. Accessed 2013/11/. <http://www.sciencedirect.com/science/article/pii/S0079670013000476>.
- Resinex. 2016a. "About us - The presence". Accessed 11/09/2016. <http://www.resinex.co.uk/about-us/the-presence.html>.

- . 2016b. "PLA Ingeo™ biopolymer". Accessed 08/04/2016. <http://www.resinex.pt/produtos/natureworks-ingeo.html>.
- RLDH. "Tablio Mini Desk". Accessed 01/06/2016. <http://www.rl-dh.com/tablio-mini-desk-amber/>.
- Roszak, Theodore. 1992. *The voice of the Earth: an exploration of ecopsychology*.
- Royal Craft Wood. "Lap Desk Slate, Bamboo Student LapDesk Stand for 11" -13" -15" Laptop, with Cooling and Mouse Pad". Accessed 08/03/2017. [http://royalcraftwood.com/?page\\_id=6302](http://royalcraftwood.com/?page_id=6302).
- Russ, Tom. 2010. *Sustainability and Design Ethics*: CRC Press.
- Rust Brothers. "About & Community". Accessed 11/12/2016. <http://rustbrothers.com/community/>.
- . "Nuxite". Accessed 01/12/2016. <http://rustbrothers.com/surface/walnut/>.
- Sastri, Vinny R. 2014. "9 - Other Polymers: Styrenics, Silicones, Thermoplastic Elastomers, Biopolymers, and Thermosets." In *Plastics in Medical Devices (Second Edition)*, 215-261. Oxford: William Andrew Publishing. <http://www.sciencedirect.com/science/article/pii/B9781455732012000094>.
- Schofield, Jack. 2013. "How can I use laptops and tablets without suffering from physical pains?". Last modified 20/06/2013. Accessed 17/02/2017. <https://www.theguardian.com/technology/askjack/2013/jun/20/using-laptops-tablets-physical-pains>.
- Soroudi, Azadeh, and Ignacy Jakubowicz. 2013. "Recycling of bioplastics, their blends and biocomposites: A review." *European Polymer Journal* no. 49 (10):2839-2858. <http://www.sciencedirect.com/science/article/pii/S0014305713003674>.
- Statista. "Shipment forecast of laptops, desktop PCs and tablets worldwide from 2010 to 2020 (in million units)". Accessed 01/03/2017. <https://www.statista.com/statistics/272595/global-shipments-forecast-for-tablets-laptops-and-desktop-pcs/>.
- Stood. "Wooden Laptop Stand". Accessed 01/06/2016. <https://stood.it/>.
- Subramanian, Muralisrinivasan Natamai. 2013. *Plastics Additives and Testing*. Somerset, US: Wiley-Scrivener.
- The George Mateljan Foundation. "Almonds". Accessed 13/04/2017. <http://www.whfoods.com/genpage.php?tname=foodspice&dbid=20>.
- TNN. 2016. "Harmful effects of placing laptop directly on your lap". Last modified 07/01/2016. Accessed 06/03/2017. <http://timesofindia.indiatimes.com/life-style/health-fitness/health-news/Harmful-effects-of-placing-laptop-directly-on-your-lap/articleshow/14232997.cms>.
- Valdés García, Arantzazu, Marina Ramos Santonja, Ana Beltrán Sanahuja, and María del Carmen Garrigós Selva. 2014. "Characterization and degradation characteristics of poly( $\epsilon$ -caprolactone)-based composites reinforced with almond skin residues." *Polymer Degradation and Stability* no. 108:269-279. <http://www.sciencedirect.com/science/article/pii/S0141391014000937>.
- Vink, Erwin T. H., and Steve Davies. 2015. "Life Cycle Inventory and Impact Assessment Data for 2014 Ingeo Polylactide Production". *Industrial Biotechnology*, June 2015. <http://online.liebertpub.com/doi/abs/10.1089/ind.2015.0003>.
- Whiteley, Nigel. 1993. *Design for Society*: Reaktion Books Ltd.
- Whomade. "Foodscapes". Accessed 11/12/2016. <http://www.whomade.it/prodotti.php/en/foodscapes/545>.
- . "Team". Accessed 11/12/2016. <http://www.whomade.it/listagallery.php/en/team/450>.
- Wickens, G. E. 1995. *Edible Nuts*. Rome: Food and Agriculture Organization of the United Nations.
- Woody Life. "Up". Accessed 07/03/2017. <http://www.woodylife.me/up.html>.



- Yates, Madeleine R., and Claire Y. Barlow. 2013. "Life cycle assessments of biodegradable, commercial biopolymers—A critical review." *Resources, Conservation and Recycling* no. 78:54-66. <http://www.sciencedirect.com/science/article/pii/S0921344913001407>.
- Zaikov, G. E., and Alfonso Jiménez. 2011. *Biodegradable Polymers and Sustainable Polymers (BIOPOL-2009)*, Materials Science and Technologies. New York: Nova Science Publishers, Inc.



## 6. Appendix



## 6.1. Appendix I

### Ingeo™ 3251D

NatureWorks® LLC - Polylactic Acid

Units 51

#### General Information

##### Product Description

Ingeo biopolymer 3251D is designed for injection molding applications. This polymer grade has a higher melt flow capability than other Ingeo resin grades currently in the marketplace. The higher flow capability allows for easier molding of thin-walled parts.

It is designed for injection molding applications, both clear and opaque, requiring high gloss, UV resistance and stiffness.

##### General

Material Status	<ul style="list-style-type: none"> <li>Commercial: Active</li> </ul>		
Availability	<ul style="list-style-type: none"> <li>Africa &amp; Middle East</li> <li>Asia Pacific</li> </ul>	<ul style="list-style-type: none"> <li>Europe</li> <li>Latin America</li> </ul>	<ul style="list-style-type: none"> <li>North America</li> </ul>
Features	<ul style="list-style-type: none"> <li>Biodegradable</li> <li>Compostable</li> <li>Food Contact Acceptable</li> </ul>	<ul style="list-style-type: none"> <li>Good Stiffness</li> <li>Good UV Resistance</li> <li>High Flow</li> </ul>	<ul style="list-style-type: none"> <li>High Gloss</li> <li>Renewable Resource Content</li> </ul>
Uses	<ul style="list-style-type: none"> <li>Thin-walled Parts</li> </ul>		
Agency Ratings	<ul style="list-style-type: none"> <li>ASTM D 6400</li> <li>EN 13432</li> </ul>	<ul style="list-style-type: none"> <li>EU 10/2011</li> <li>EU 94/62/EC</li> </ul>	<ul style="list-style-type: none"> <li>FDA Food Contact, Unspecified Rating</li> </ul>
Appearance	<ul style="list-style-type: none"> <li>Clear/Transparent</li> </ul>	<ul style="list-style-type: none"> <li>Opaque</li> </ul>	
Forms	<ul style="list-style-type: none"> <li>Pellets</li> </ul>		
Processing Method	<ul style="list-style-type: none"> <li>Injection Molding</li> </ul>		

#### ASTM & ISO Properties <sup>1</sup>

Physical	Nominal Value	Unit	Test Method
Specific Gravity	1.24	g/cm <sup>3</sup>	ASTM D792
Melt Mass-Flow Rate (MFR)			ASTM D1238
190°C/2.16 kg		35 g/10 min	
210°C/2.16 kg		80 g/10 min	
Molding Shrinkage - Flow	0.30 to 0.50	%	
Relative Viscosity	2.50		
Mechanical	Nominal Value	Unit	Test Method
Tensile Strength (Yield)	62.1	MPa	ASTM D638
Tensile Elongation (Break)	3.5	%	ASTM D638
Flexural Strength	108	MPa	ASTM D790
Impact	Nominal Value	Unit	Test Method
Notched Izod Impact	16	J/m	ASTM D256
Thermal	Nominal Value	Unit	Test Method
Glass Transition Temperature	55.0 to 65.0	°C	ASTM D3417
Peak Crystallization Temperature (DSC)	155 to 170	°C	ASTM D3418
Optical	Nominal Value	Unit	Test Method
Clarity	Transparent		

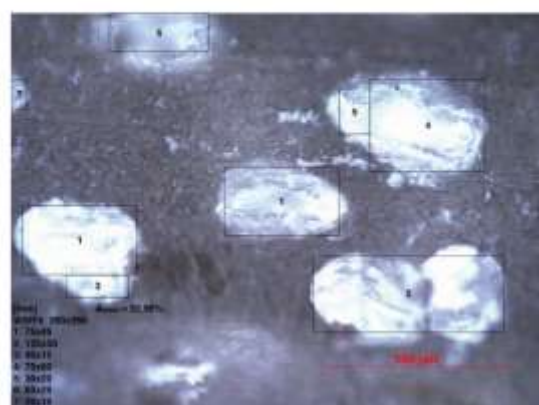
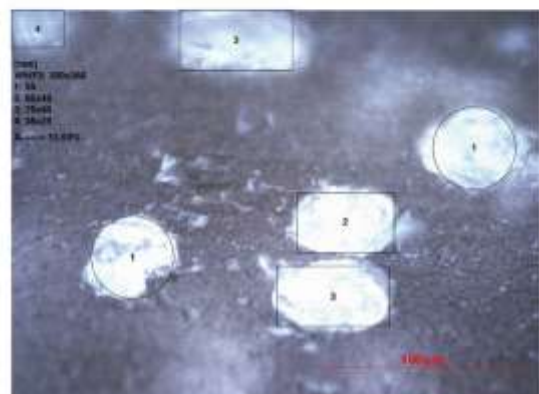
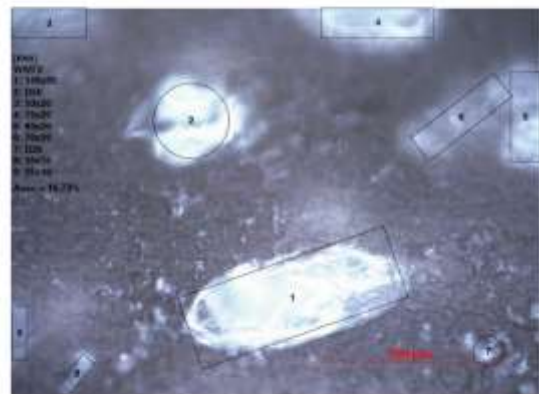
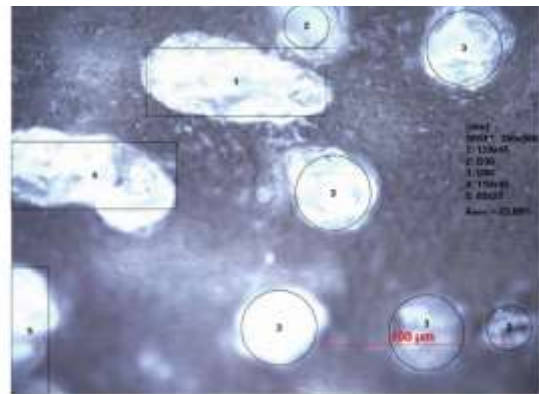
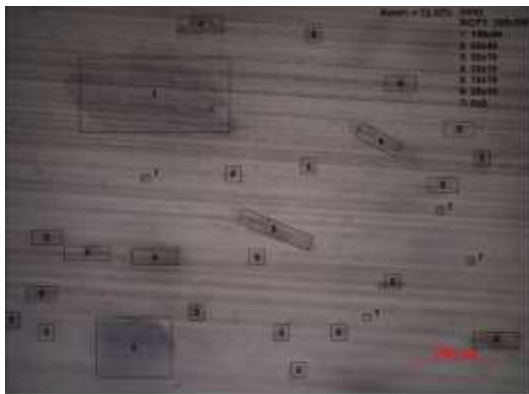
#### Processing Information

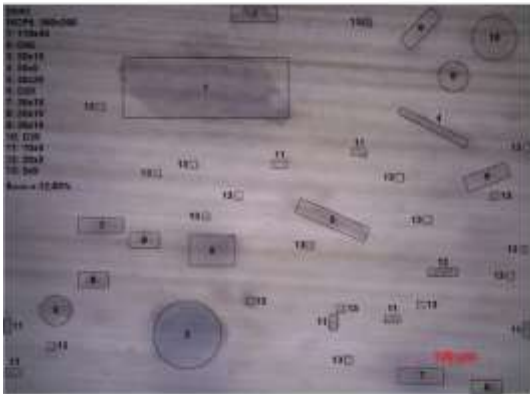
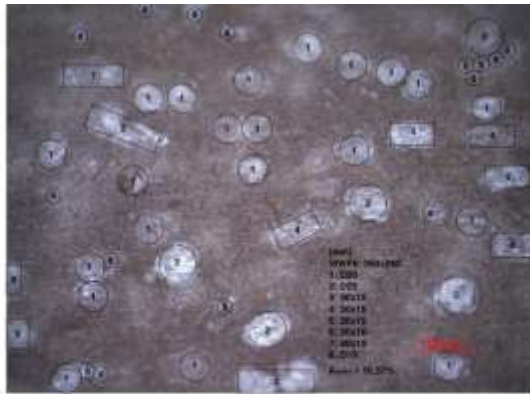
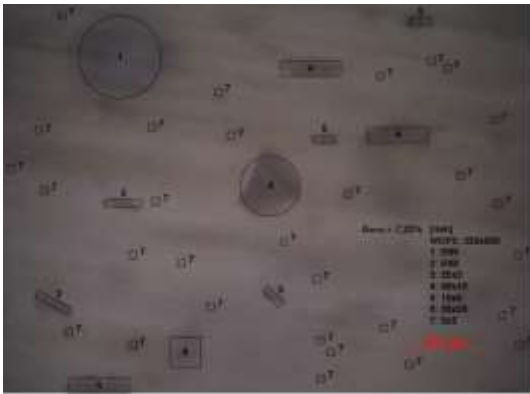
Injection	Nominal Value	Unit
Suggested Max Moisture	< 0.010	%
Rear Temperature	166 to 177	°C
Middle Temperature	182 to 193	°C
Front Temperature	188 to 205	°C
Nozzle Temperature	188 to 205	°C
Processing (Melt) Temp	188 to 210	°C
Mold Temperature	25.0	°C
Back Pressure	0.345 to 0.689	MPa
Screw Speed	100 to 200	rpm

#### Notes

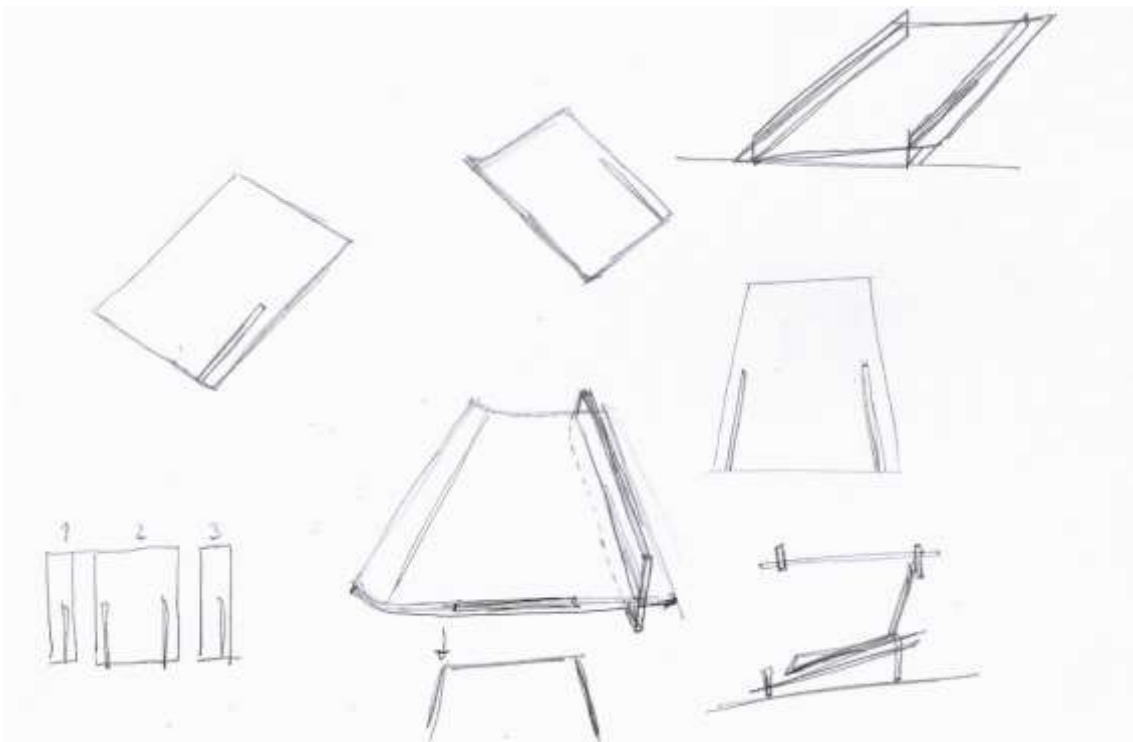
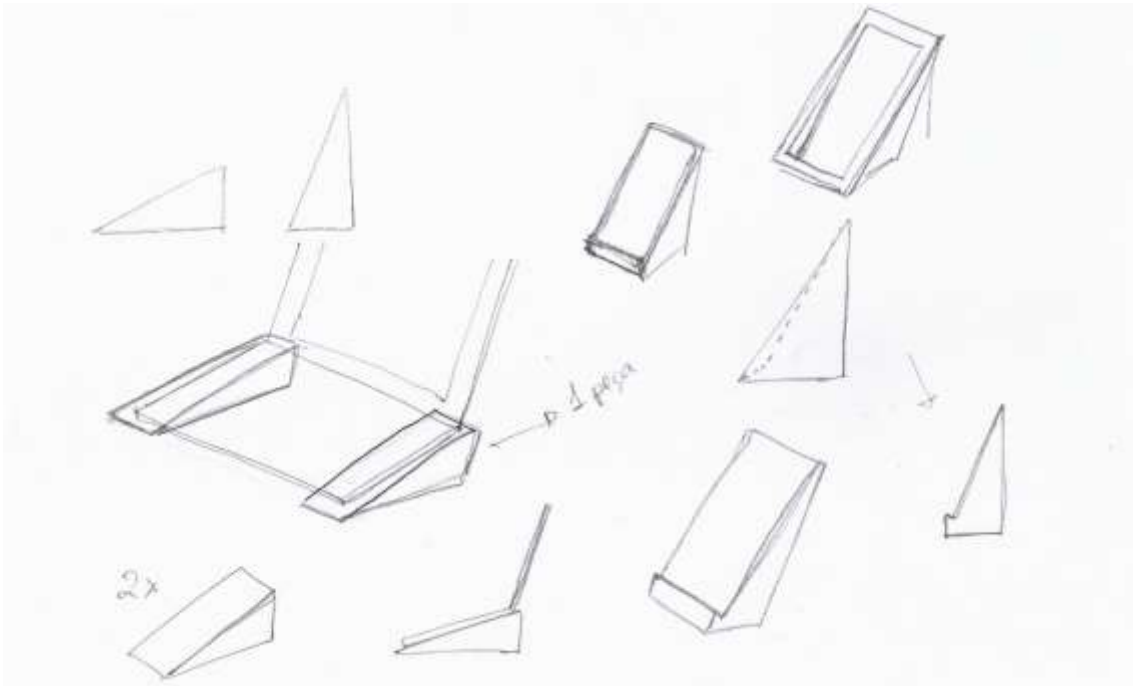
<sup>1</sup> Typical properties; these are not to be construed as specifications.

## 6.2. Appendix II

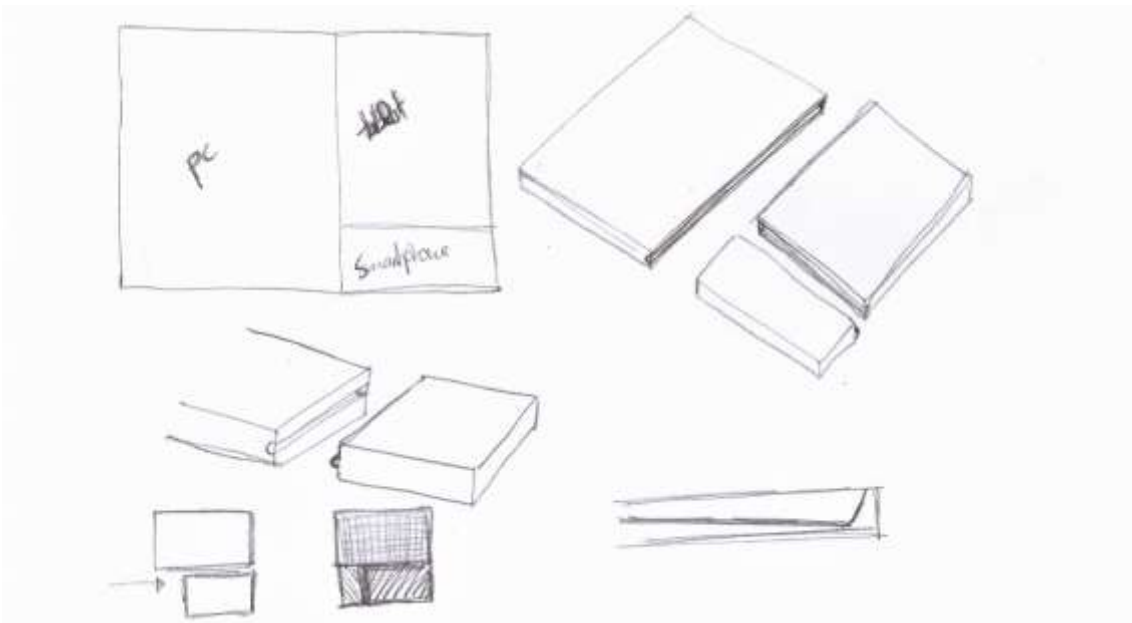
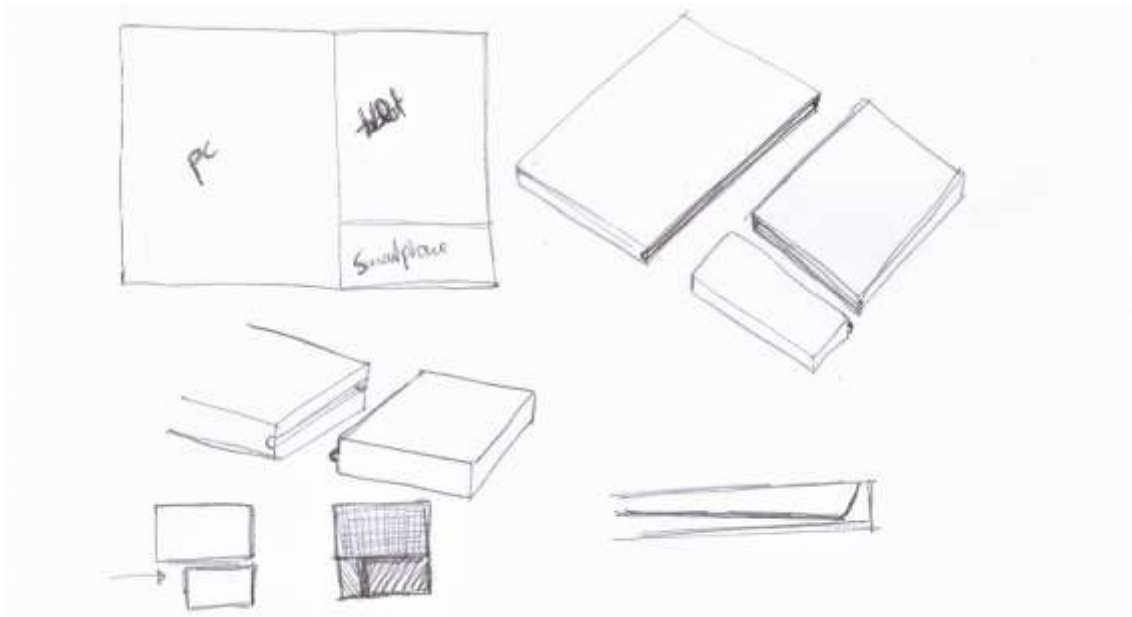




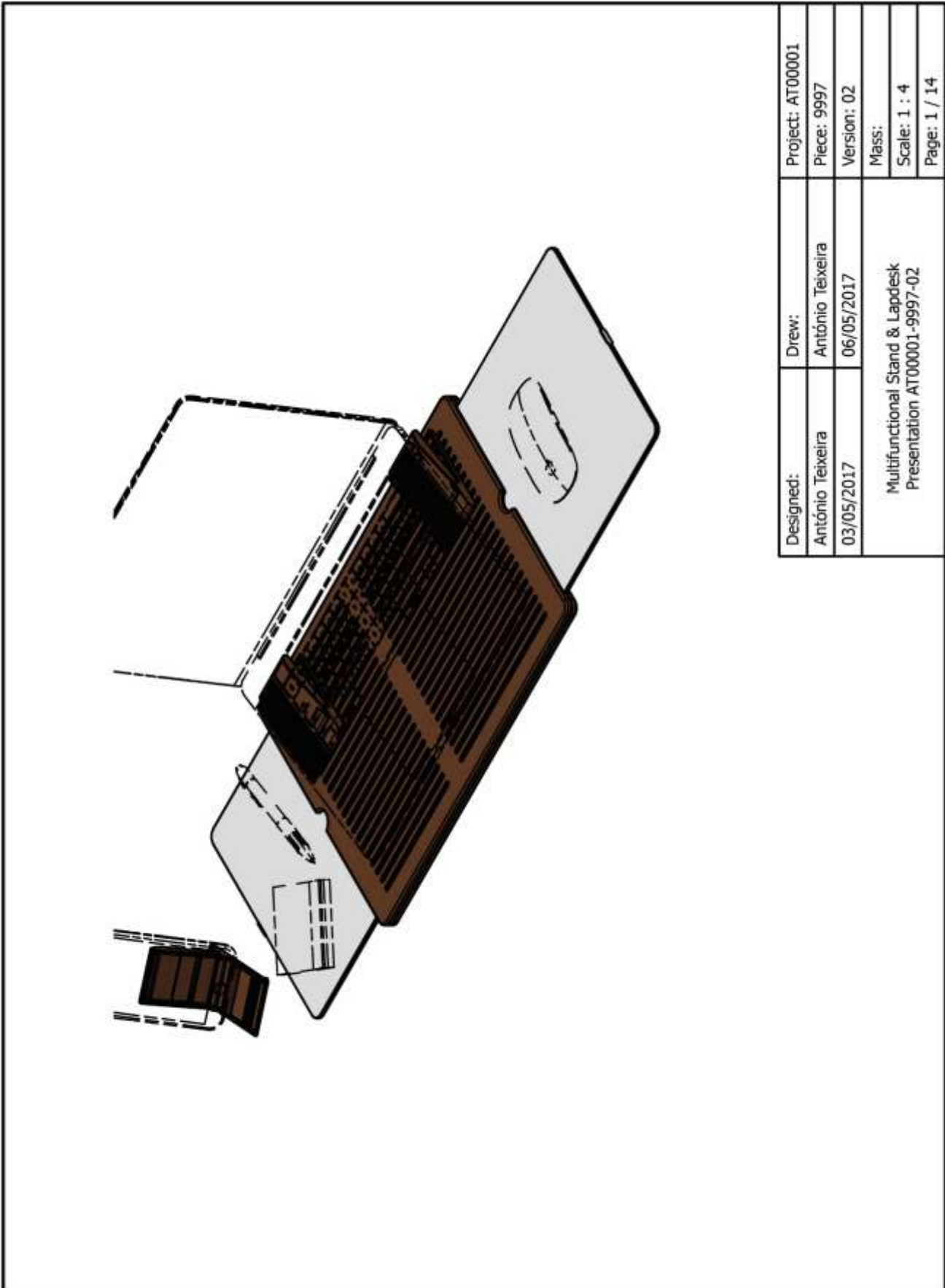
### 6.3. Appendix III

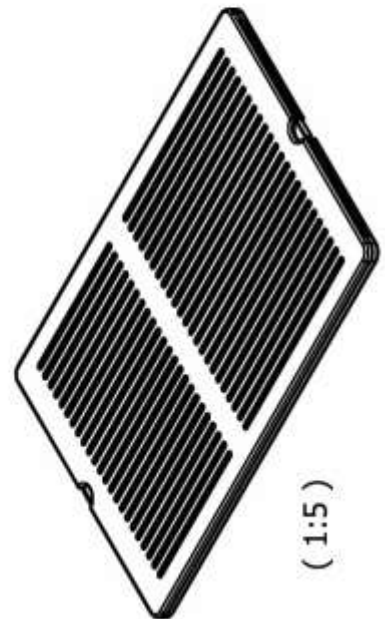
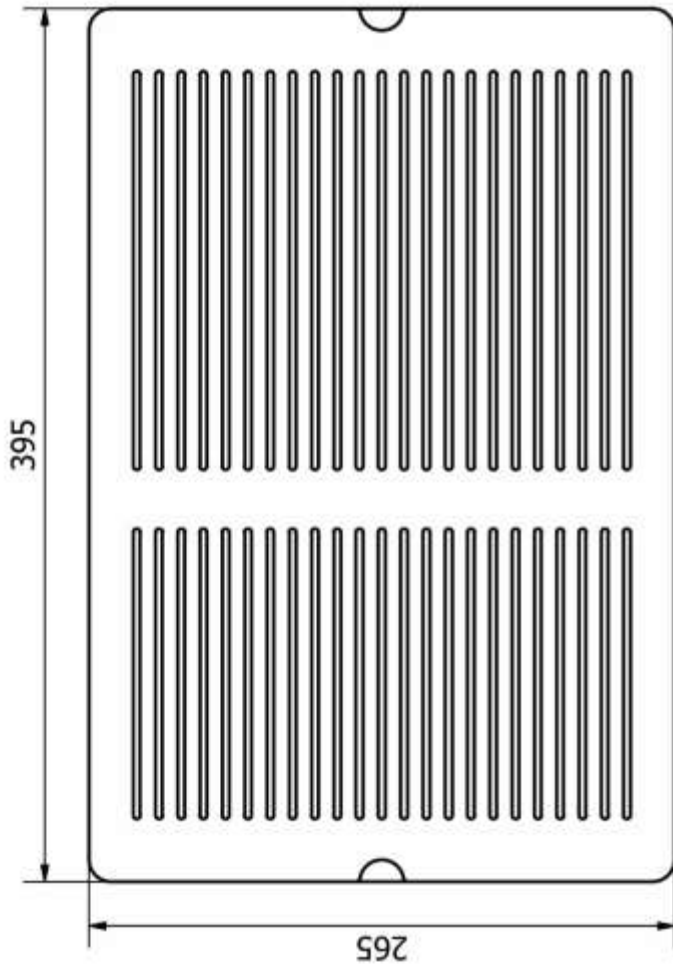
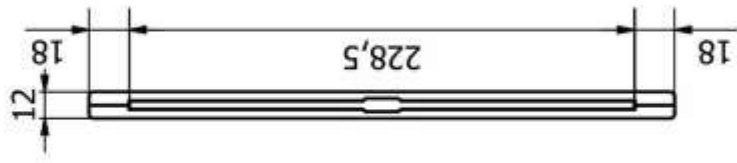






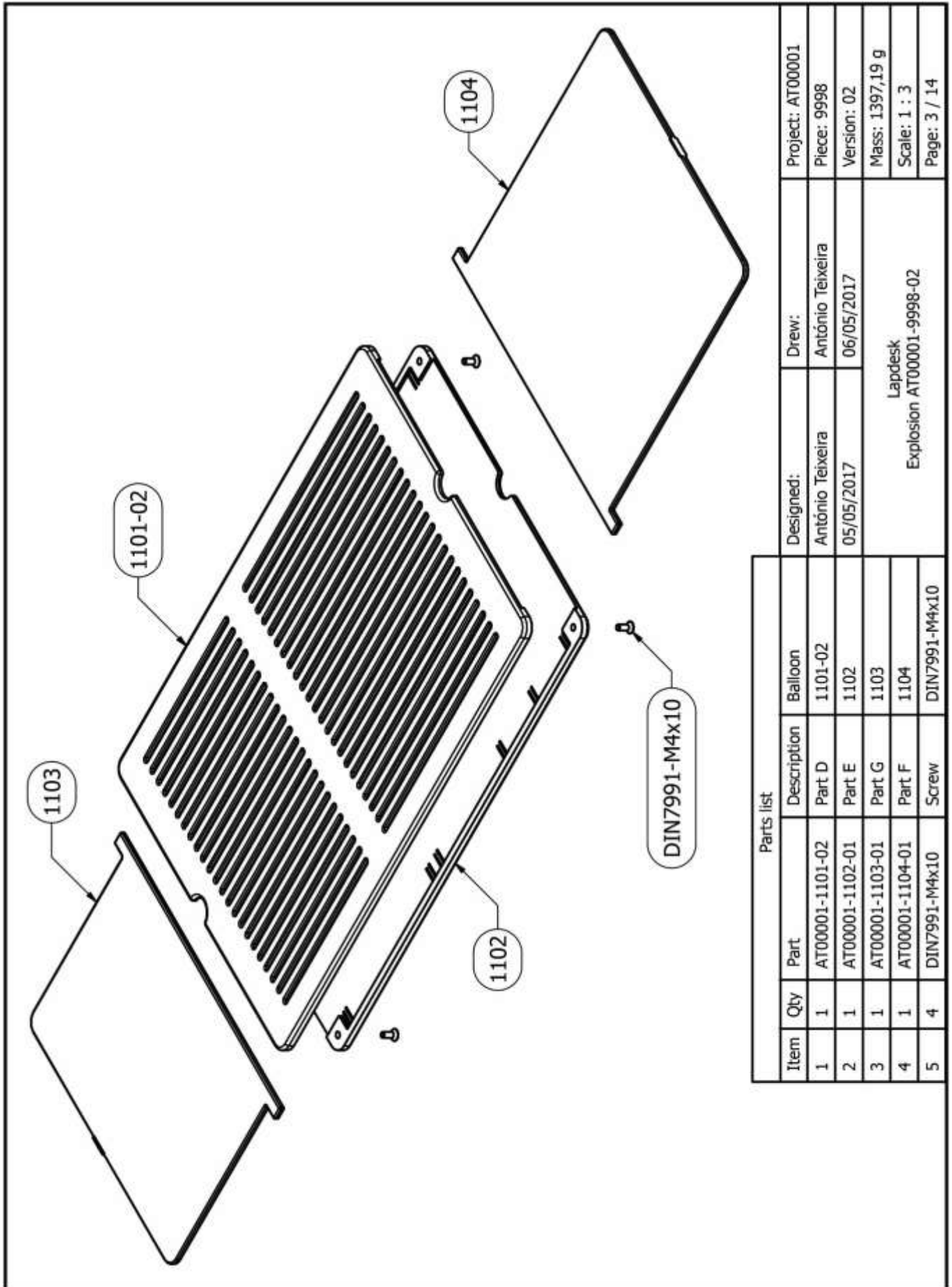
## 6.4. Appendix IV





( 1:5 )

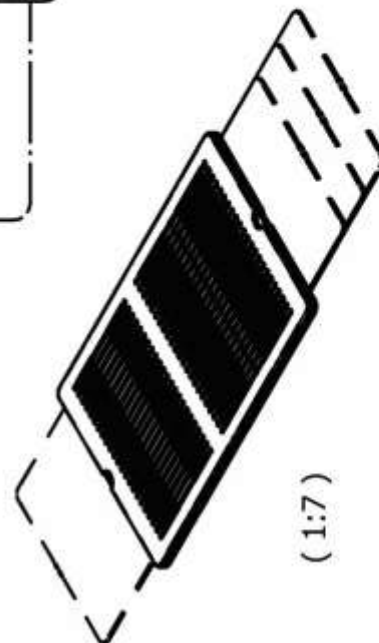
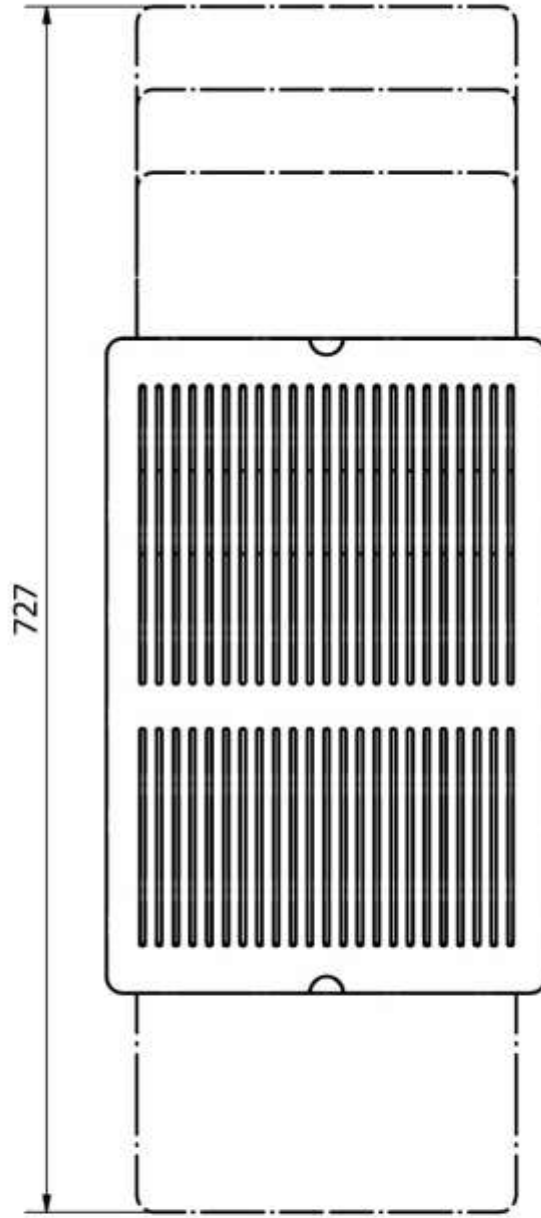
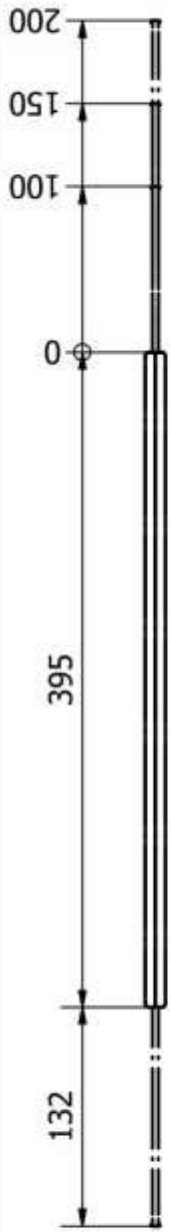
Designed:	Drew:	Project: AT000001
António Teixeira	António Teixeira	Piece: 9998
02/05/2017	06/05/2017	Version: 02
Lapdesk		Mass: 1397,19 g
Assembly AT000001-9998-02		Scale: 1 : 3
		Page: 2 / 14



Parts list

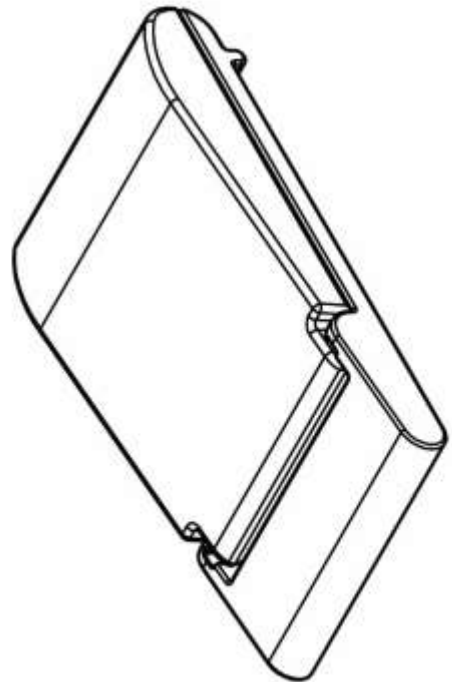
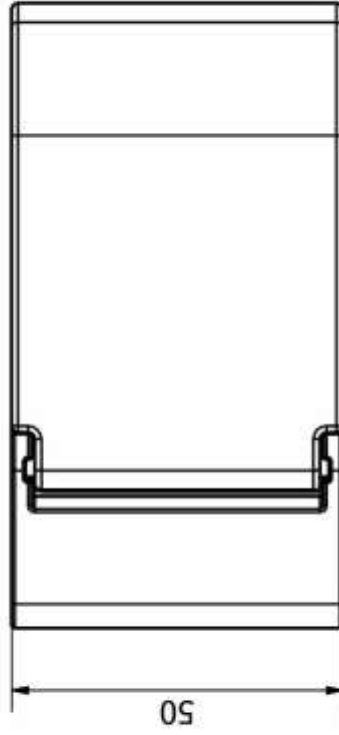
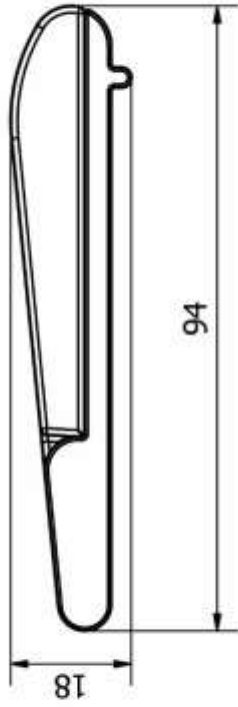
Item	Qty	Part	Description	Balloon
1	1	AT00001-1101-02	Part D	1101-02
2	1	AT00001-1102-01	Part E	1102
3	1	AT00001-1103-01	Part G	1103
4	1	AT00001-1104-01	Part F	1104
5	4	DIN7991-M4x10	Screw	DIN7991-M4x10

Designed:	Drew:	Project: AT00001
António Teixeira	António Teixeira	Piece: 9998
05/05/2017	06/05/2017	Version: 02
Lapdesk		Mass: 1397,19 g
Explosion AT00001-9998-02		Scale: 1 : 3
		Page: 3 / 14

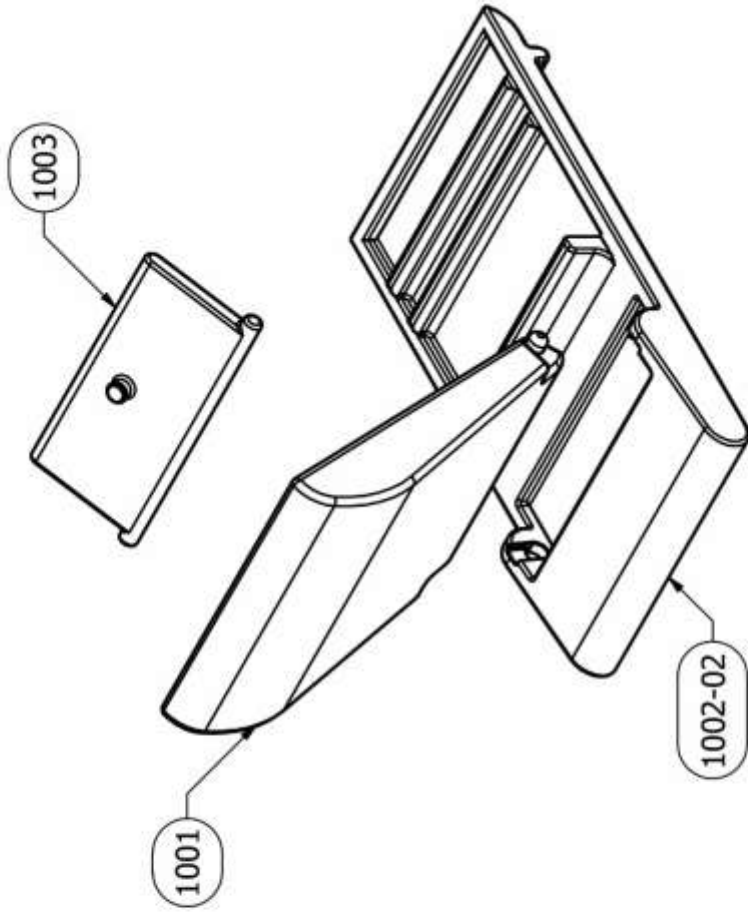


( 1:7 )

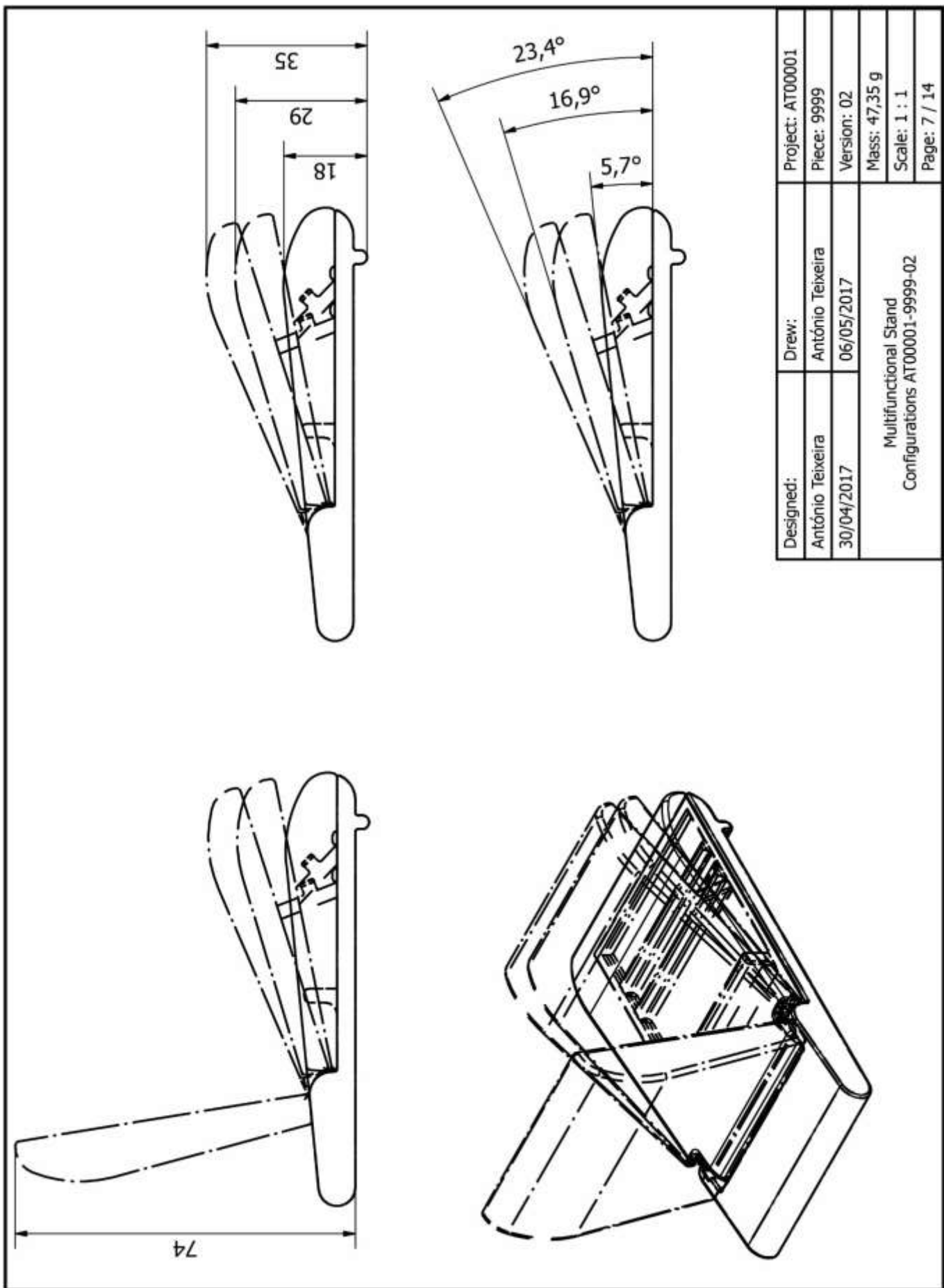
Designed:	Drew:	Project: AT00001
António Teixeira	António Teixeira	Piece: 9998
02/05/2017	06/05/2017	Version: 02
Lapdesk		Mass: 1397,19 g
Configurations AT00001-9998-02		Scale: 1 : 4
		Page: 4 / 14



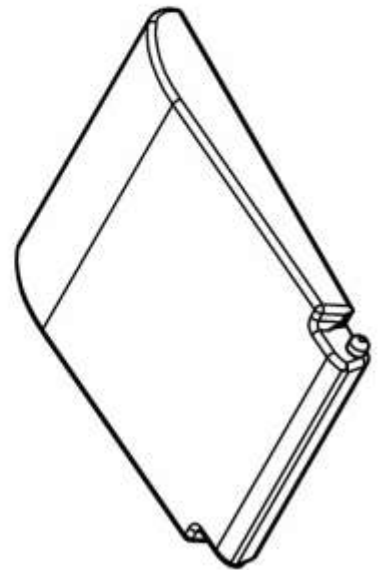
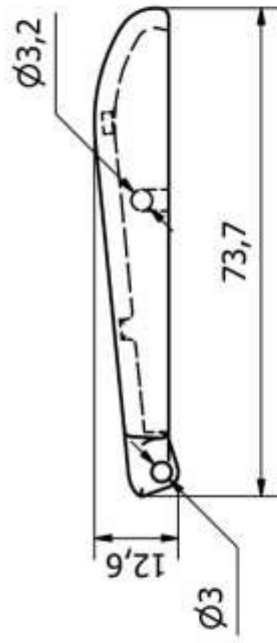
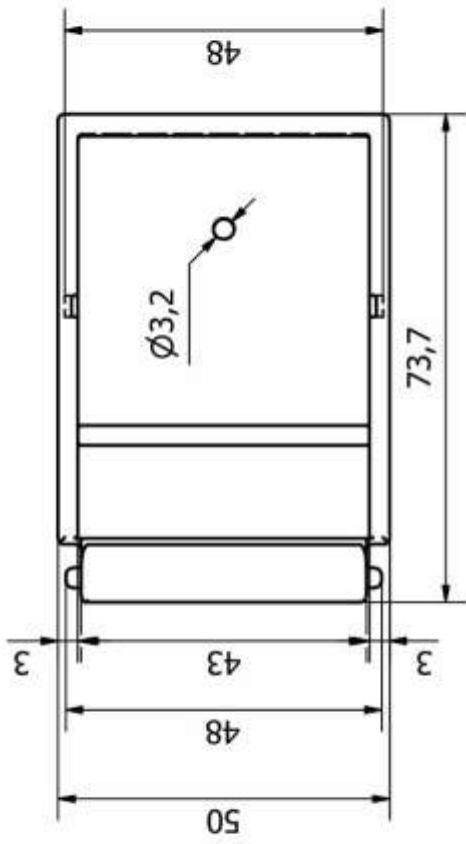
Designed:	Drew:	Project: AT00001
António Teixeira	António Teixeira	Piece: 9999
30/04/2017	06/05/2017	Version: 02
Multifunctional Stand Assembly AT00001-9999-02		Mass: 47,35 g
		Scale: 1 : 1
		Page: 5 / 14



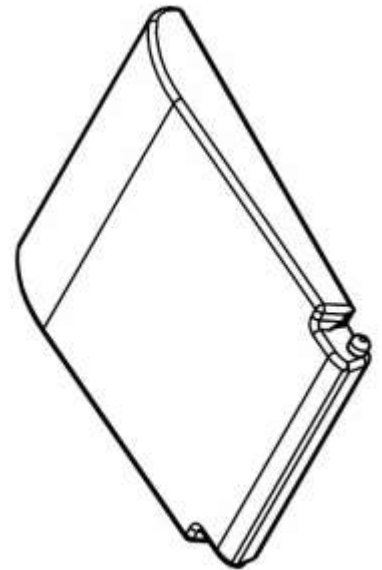
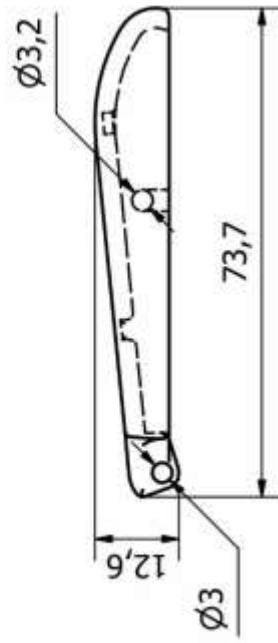
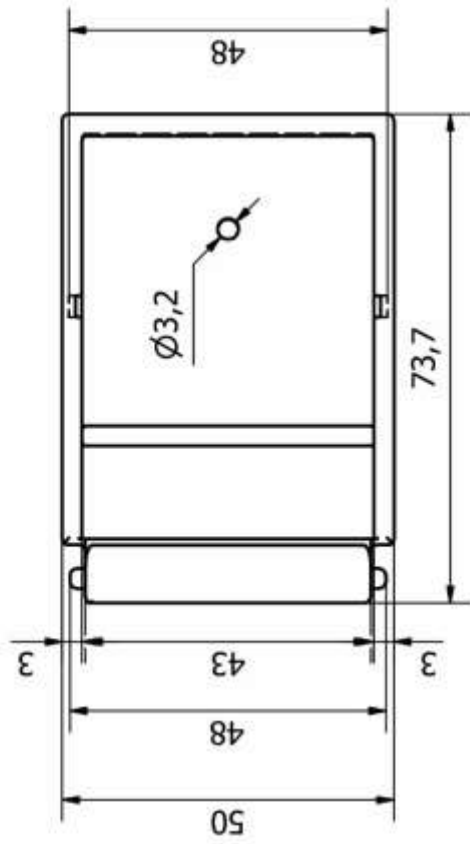
Parts list			Designed:		Drew:		Project: AT00001		
Item	Qty	Part	Description	António Teixeira	António Teixeira	05/05/2017	06/05/2017	Piece: 9999	
1	1	AT00001-1001-01	Part A'	Multifunctional Stand Explosion AT00001-9999-02					Version: 02
2	1	AT00001-1002-02	Part B'						Mass: 47,35 g
3	1	AT00001-1003-01	Part C'						Scale: 1 : 1
									Page: 6 / 14





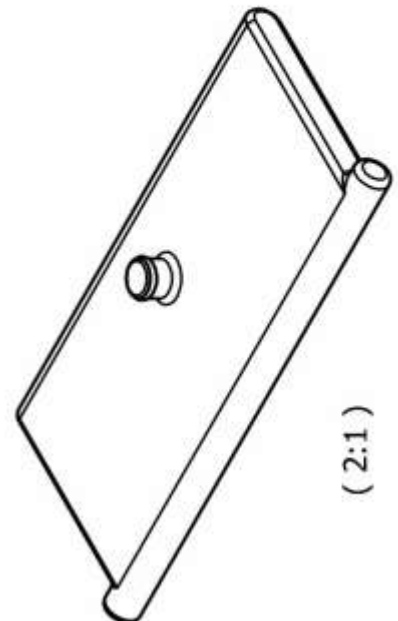
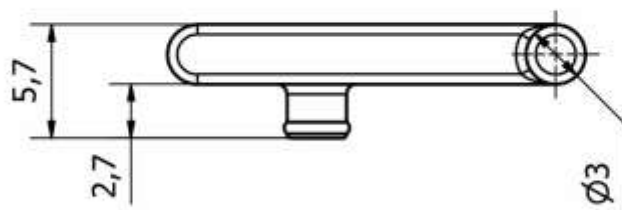
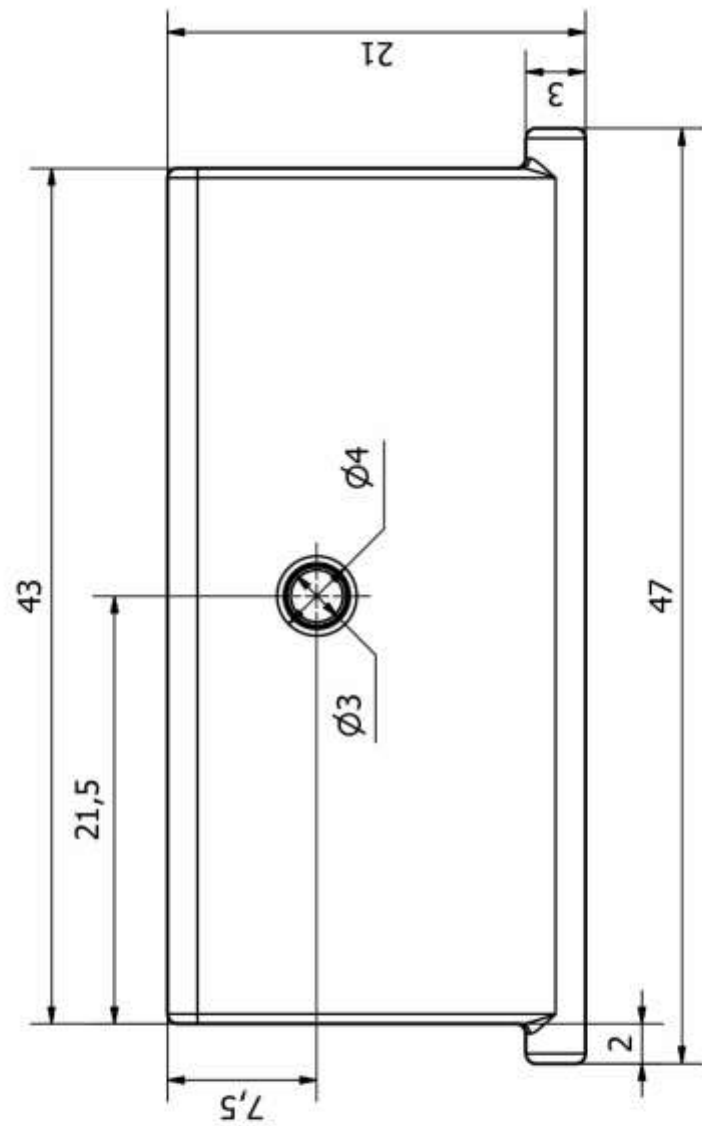


Designed:	Drew:	Project: AT000001
António Teixeira	António Teixeira	Piece: 1001
29/04/2017	06/05/2017	Version: 01
Multifunctional Stand - Part A'		Mass: 19 g
Part AT00001-1001		Scale: 1 : 1
		Page: 8 / 14

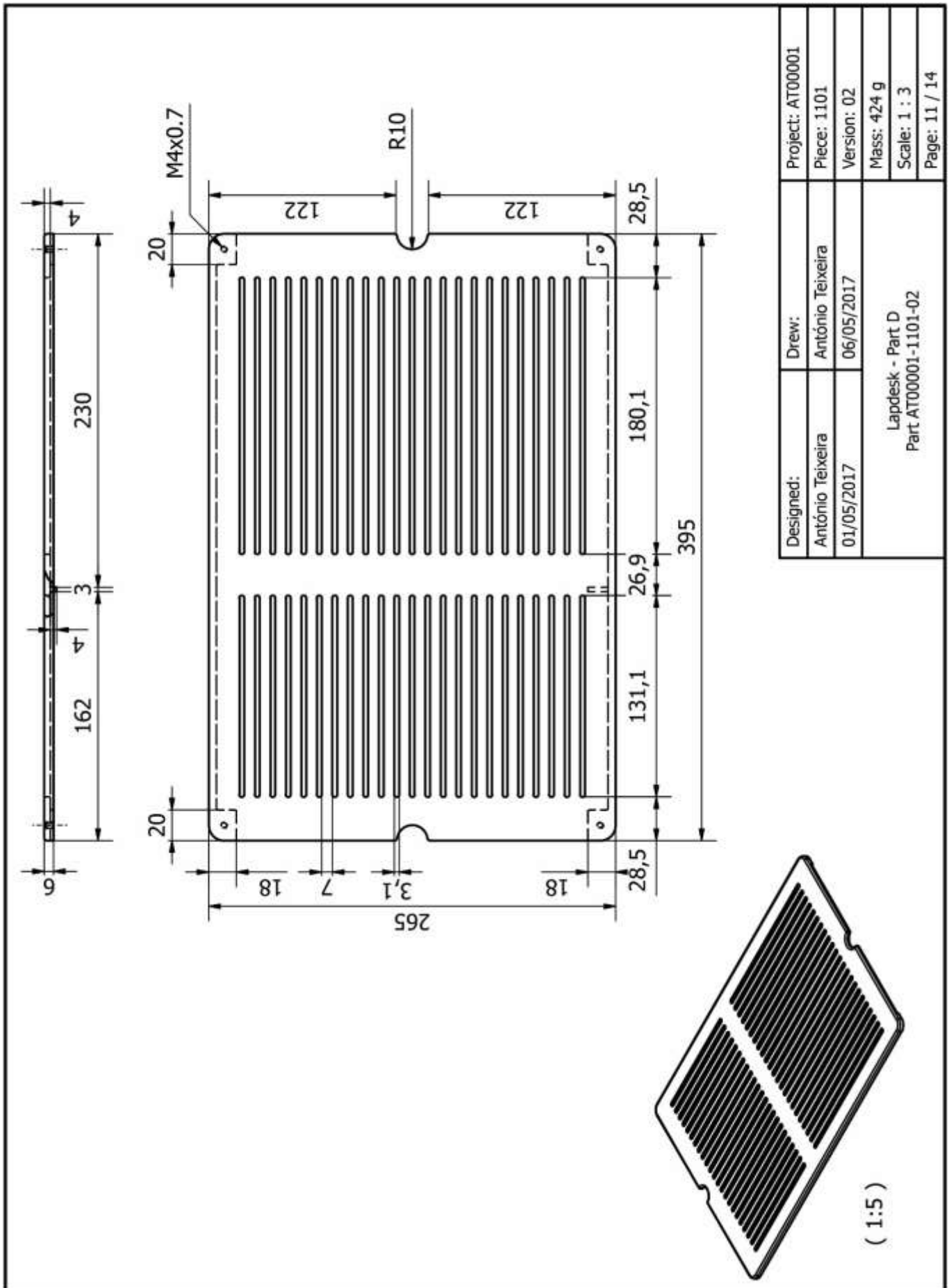


Designed:	Drew:	Project: AT000001
António Teixeira	António Teixeira	Piece: 1001
29/04/2017	06/05/2017	Version: 01
Multifunctional Stand - Part A'		Mass: 19 g
Part AT00001-1001		Scale: 1 : 1
		Page: 8 / 14





Designed:	Drew:	Project: AT00001
António Teixeira	António Teixeira	Piece: 1003
29/04/2017	06/05/2017	Version: 01
Multifunctional Stand - Part C		Mass: 3 g
Part AT00001-1003		Scale: 3 : 1
		Page: 10 / 14

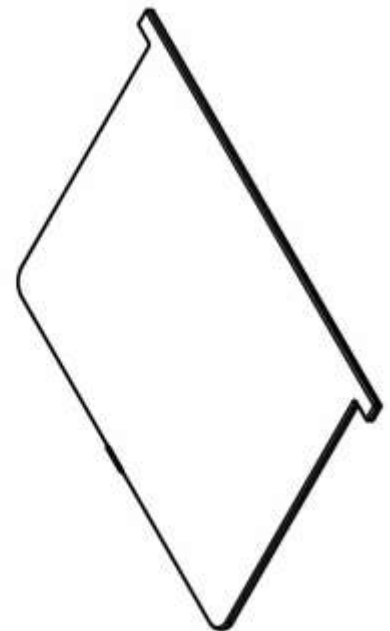
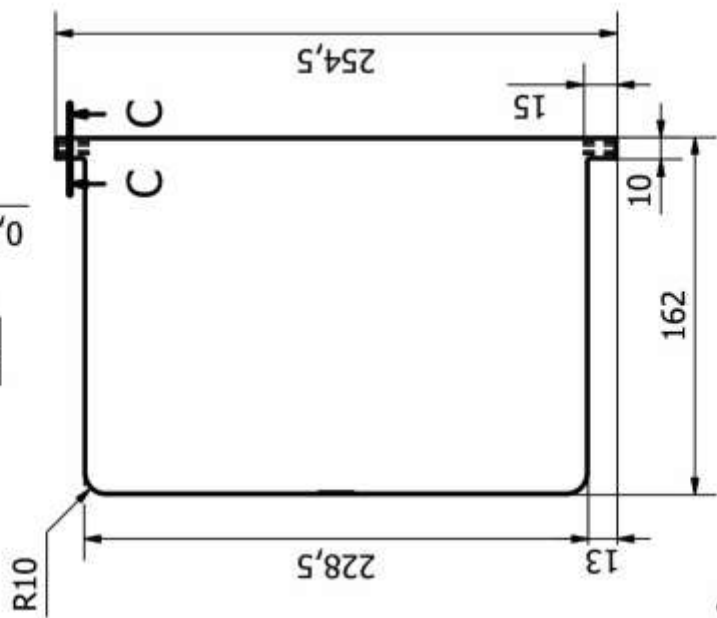
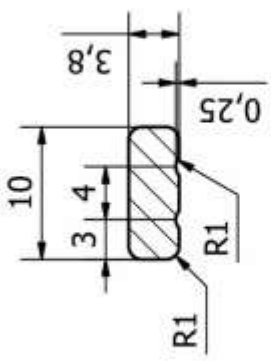
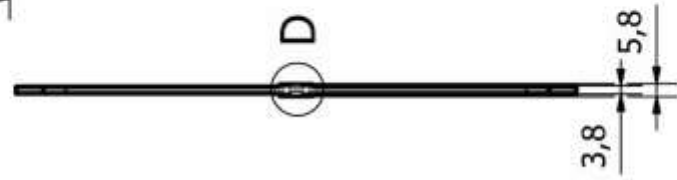
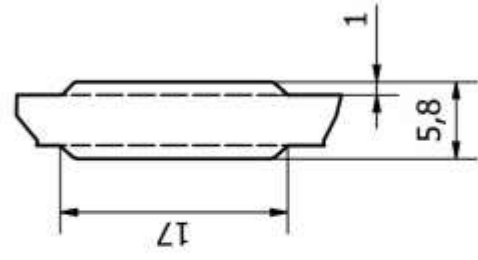


Designed:	Drew:	Project: AT000001
António Teixeira	António Teixeira	Piece: 1101
01/05/2017	06/05/2017	Version: 02
Lapdesk - Part D		Mass: 424 g
Part AT000001-1101-02		Scale: 1 : 3
		Page: 11 / 14



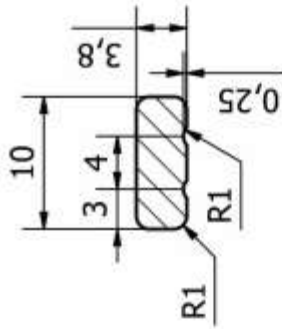
C-C (2:1)

D (2:1)

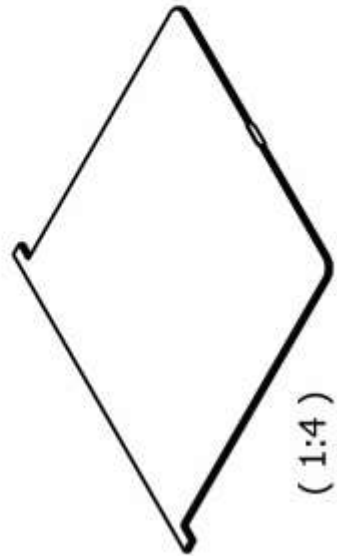
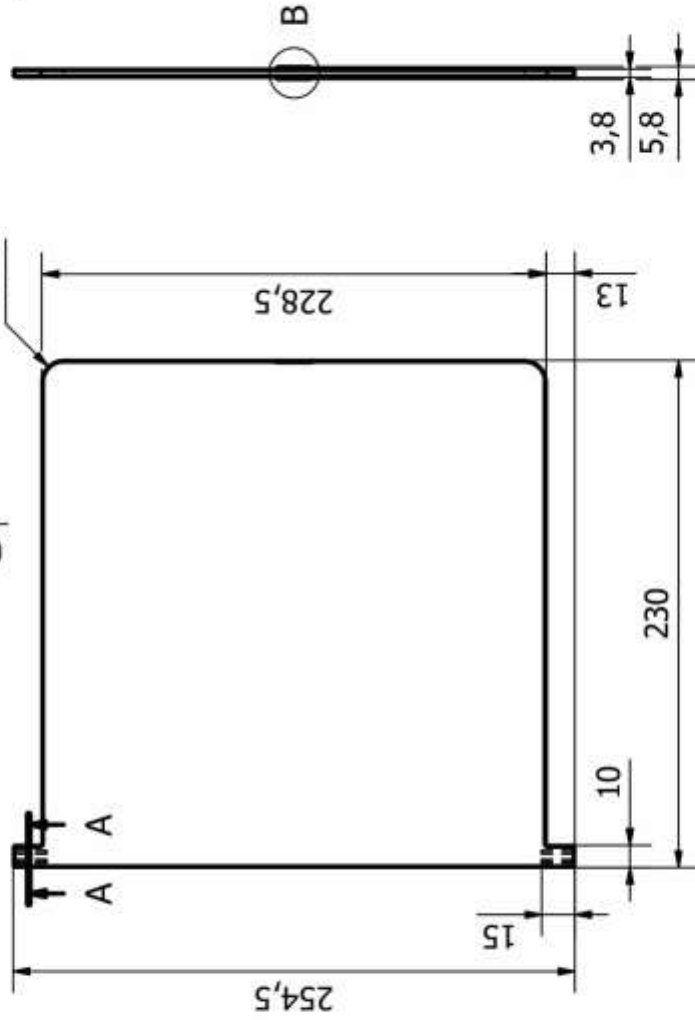
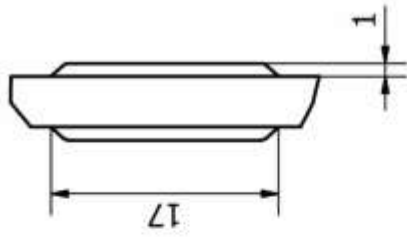


Designed:	Drew:	Project: AT00001
António Teixeira	António Teixeira	Piece: 1103
01/05/2017	06/05/2017	Version: 01
Lapdesk - Part G		Mass: 175 g
Part AT00001-1103		Scale: 1 : 3
		Page: 13 / 14

A-A ( 2:1 )



B ( 2:1 )



( 1:4 )

Designed:	Drew:	Project: AT00001
António Teixeira	António Teixeira	Piece: 1104
01/05/2017	06/05/2017	Version: 01
Lapdesk - Part F		Mass: 248 g
Part AT00001-1104		Scale: 1 : 3
		Page: 14 / 14



## 6.5. Appendix V

Below is presented the full paper, *Valorisation of different wastes: a sustainable approach in the design of new products*, written together with, Doctor Jorge Lino Alves, Doctor Bárbara Rangel, Daniela Monteiro, Ruben Ribeiro and Vasco Canavarro for the *4<sup>th</sup> International Conference on Wastes: Solutions, Treatments and Opportunities*. This paper has already been accepted and will be included in the book published by *CRC Press – Taylor & Francis Group*, that will be proposed to *Scopus and Thomson Reuters* for indexing. The presentation of the paper, will be held at Porto on 25<sup>th</sup> and 26<sup>th</sup> of September of 2017.

# Valorisation of different wastes: a sustainable approach in the design of new products

A. Teixeira, D. Monteiro, R. Ribeiro & V. Canavarro

*Master in Product and Industrial Design, University of Porto, 4200-465 Porto, Portugal*

B. Rangel

*Design Studio FEUP, Faculty of Engineering of University of Porto, 4200-465 Porto, Portugal*

J. L. Alves

*INEGI and Design Studio FEUP, Faculty of Engineering of University of Porto, 4200-465 Porto, Portugal*

**ABSTRACT:** In 2014, 2.502 million of tons of waste were generated in EU-28 by all economic activities and households, and it is forecasted that this number is not going to be reduced. So, it is a society obligation to search for solutions for this problem, and the designers have an increased responsibility to change this reality. Different wastes were valued through design and engineering, seeking the creation of materials to be applied in the development of new products. The different proposals involved the use of fishing ropes and nets debris, almond by-product residues, coffee waste and Portuguese pine resin as an underexploited resource.

## 1 INTRODUCTION

According to Eurostat (Statistical Office of the European Union), Portugal generated in 2014, 14,586,917 tons of waste (Eurostat, 2017). On the other hand, Europe (28 Countries) ended the same year with 2,502,890,000 tons and, in 2012, in the United States, 624,700 tons of solid waste are daily generated and the forecast made by The World Bank Organization through the document "What a Waste" (Bhada-Tata, 2012) is that by 2025 it will be 701,709 tons.

Facing this situation, efforts should be made to develop more environmentally friendly solutions, intervening, for example, in using materials that can be reused or recycled. In 2015, under the Community Service Engineering European program, it was proposed a project We-Won'tWasteYOU for the students of the Master in Product and Industrial Design, in the scope of the Project Design course, in a partnership with the City Council of Matosinhos. The students were asked to develop products using wastes and/or residues of the industries of the city of Matosinhos that could be produced with low-tech tools, so that a small group of unemployed people were able to start a small production. After ending this unit course, the project motivated some students to continue exploring the use of wastes during their thesis. Below are presented four research works of four students which explored the use of fishing ropes and nets debris, almond by-products residues, coffee waste and Portuguese pine resin as an underexploited resource, that were applied as raw material for new products.

## 2 RESEARCH FOR USING WASTES IN NEW APPLICATIONS

### 2.1 *Design as a vehicle for using fishing waste to create new products*

The world's oceans are full of discarded debris that degrade and sink or drift ashore which have a very negative impact in the marine environment. Ghost nets, which are deliberately or accidentally lost in the oceans, usually by fishermen, are responsible of the entrapment and killing of many animals and they also may damage and destroy coral reefs through marine currents (World Ocean Review). According to United Nations Environment Programme, it is estimated that there are 640,000 tons of ghost nets worldwide (Shea, 2014).

Through this research, it was intended to study the potential of waste from fishing activities and the best way to transform them into raw material for new products. According to literature review, two companies deserve to be highlighted since they claim to use only recycled material in the creation of their products. Firstly, Aquafil Group, a global leader in the synthetic fibres industry, created the ECONYL®, a Nylon6 100% regenerated yarn from fishing ropes and nets (FRN), carpets and cloths (Econyl). Secondly, Bureo conceives innovative solutions to the growing problem of plastic pollution in the oceans by developing products with sustainable design, as for example, skateboards and sunglasses (Bureo).

Followed by the literature review, it was proceeded to the collection of FRN debris at Do-capesca, in Matosinhos, to start the experimental work. Before starting with the experimentation of the transformation of FRN debris, it was important to identify their polymers. Bearing this in mind, a method of identification of polymers created and provided by a Professor from FEUP was used for four types of residues. The method consisted in immersion of the polymers in water and ethyl acetate, scratch them with the fingernail, exposure to the flame and smell of the smoke after being extinguished. The results showed that three of the samples correspond to a High-Density Polyethylene (HDPE), while the other is a Polyamide (PA).

The first transformation experiments were conducted in a vertical injection moulding machine using the debris. The materials were previously cut into small pieces to fill the cylinder of the machine and, then, injected into a small mould. With these experiments, it was verified that the recycled HDPE had a high viscosity, inhibiting the flow of the material through the sprue bushing, having never filled the mould. For last experiments, it was used a silicon mould of a cup where melted material was cast and manually pressed. These experiments showed that a good combination of parameters allows the filling of the mould. However, this moulding method has proved to be unsuitable due to the high viscosity of the material.

Considering the results obtained, a different approach was tried; the direct use of the recycled material. The product has the intention to keep the connection of the FRN debris to where they came from – the ocean and beach. Taking this into consideration, a “bag backboard”, made of 100% recycled material from FRN, which allows the user to enjoy two functionalities in a single product was designed (Figure 1). This product will use the FRN in its natural state, fabric made of nylon and injected HDPE, so the bag component will be made using fishing net in its natural state allowing the sand that is always accumulated in towels and objects, such as toys, to fall off. Inside this component, there will be a small pocket made of nylon, so that the user can place smaller belongings with more value to ensure their safety.

Although the performed experiments with 100% recycled HDPE from FRN haven't been positive neither conclusive, the literature review indicated that using 100% recycled FRN and others is a reliable option, depending on the application. With this project, it can be concluded that using recycled materials, as for example, FRN, can be an excellent alternative in product design, creating more sustainable and still aesthetically pleasing solutions, avoiding the extraction of resources from nature.



Figure 1. Product designed based on the raw material from FRN debris.

## 2.2 Application of almond nuts by-products in a biocomposite

This project focused on finding a solution through design for the problem of almond nuts industry residues which are by-products of the almond nuts, such as hulls, shells and skins. Through a literature review regarding the agro-industry, it was found that about one third of edible food produced for human consumption is wasted (European). In 2013, the almond industry produced 1,823,180 tons of residues (Faostat, International Nut and Dried Fruit Council Foundation, 2015).

These, as well as other agricultural wastes, have not received enough attention, ending up being incinerated or used as biomass fuel to produce heat or generate electricity or dumped or used as animal feedstock. Besides these final uses, researchers have already studied the possibility of using the almond by-products in different applications with positive results such as, reinforcement in a polypropylene matrix and a wood based composite using urea-formaldehyde resin, absorbent of heavy metals and dyes, growing media for soilless culture and for preparing activated carbons.

According to the information from the previous paragraph, it was pretended with this project to study the possibility of employing the almond by-products in new products, by using them as a reinforcement of a polymer, thus creating a mouldable composite material. It is well known that oil-based plastic materials have unique and innumerable properties which have a big interest for manufacturers but it is also well known that they are one of the biggest pollutants on Earth. Concerning this, it was decided to use in the experimental work a PLA manufactured by Nature-Works® with the brand name of Ingeo™, which is a biodegradable biobased polymer, so a more environment friendly solution concerning its health.

Bearing this purpose in mind, by blending both materials, PLA and almond by-products, a biocomposite was obtained, which is a material 100% originated from renewable resources. For the experimental work, the almond by-products were grinded and milled in small particles. After this, the particles were sieved using a vibratory sieve shaker with the following sieves: 630, 400, 315, 125, 90 and 53  $\mu\text{m}$ . Regarding the nature of these natural fillers, before proceeding to any blend, the particles were dried in an oven to remove the majority of its moisture. Plates were successfully created by blending 10% to 50% of reinforcement of different particle sizes. However, in all particle-sizes mixtures, it is notable the increasing of the roughness and brittleness with the amount of reinforcement. Besides, increasing the particle size changes the product aesthetics, since it is possible to clearly observe the particles in the PLA mixture. It is important to refer that there isn't an ideal blending composition since this will vary depending on the intended end use for the material.

After finishing the blending experimentation, a composite material mixture with 20% of reinforcement and particle-size range from 53 $\mu\text{m}$  to 125 $\mu\text{m}$  was manually pressed in a silicon mould of a cup. The result achieved was very interesting, with great aesthetics, but the material still needs to be characterized in order to know its properties.

After achieving the main goal of this research, the design project was the creation of a laptop stand, which was intended to be low weight, adjustable, small size, and, if possible, multifunctional or adaptable to tablets or smartphones. This product can be used as a vertical support for smartphones and tablets, with two adjustable positions in height and maximum dimensions of 5x7x2 cm (length x width x height) (Figure 2). In order to be small and easy to pack, this product uses two separated laptop-stands. Considering the sizes of tablets, it may be necessary to use the two laptop stands together to hold the equipment.

This experimental work, using the almond by-products, presented positive results with room for improvement and more research. The composite can be produced with a great variety of reinforcement percentages as well as the particle-size distribution, being also possible to combine bigger particles with very small particles. After the material being characterized, it will be possible to know its potential applications.



Figure 2. Concept design of the laptop stand using the composite PLA + almond by-products.

### 2.3 *Coffee waste reused as a composite material*

Based on data provided by the International Coffee Organization, it is estimated that its overall consumption in 2014 was 149.8 million bags of 60 kg (Organization, 2015a). In the case of Portugal, in the same year, 823,000 bags of 60 kg were consumed, which represent a per capita consumption of around 4.7 kg (Organization, 2015b). According to the same source, the annual coffee demand from 2011 to 2014 increased by 2.4%. It is further noted that this increase is gradual, being registered every year. It is therefore plausible to deduce that this tendency will continue.

The research developed aims to present a production method for reuse coffee ground leftovers. The main goal is to obtain a mouldable material, composed by coffee grounds and a suitable binder. It is also intended that the created material is durable and washable, with prospects of extending the realities in which it can be used. The composite material developed within this mixture can be used in a variety of products, from simple vases, coffee table tops, to light emitting objects with original effects. The options are vast and abundant.

The base material used in the experiments was coffee grounds, obtained domestically and the only treatment given to it was, in some cases, heating it in an oven at 100 °C for 24 hours, in order to eliminate its humidity. In all other cases, it was used as is. So, in conclusion, it is obvious that the experimental work was fundamental in obtaining and developing this material. The epoxy resin experiment was valid in order to determine that coffee waste can, in fact, be mixed with other substances to achieve a composite material. It didn't work however, because it is not safe for food contact and is not biodegradable. Starch showed some promising results at the beginning, but with time it revealed great negative characteristics, with the appearance of mould on all samples. It also couldn't withstand contact with cold water, being therefore discarded. Pine resin displayed very weak results, because it couldn't be homogenized with coffee waste, not even with the addition of wax. PLA exceeded the initial expectations. It is biodegradable and the experiments showed very good results, with different formulas, permitting its use in different areas of interest. It is also FDA approved for food contact. The final material is not, however, perfect or completely developed. It does not withstand high temperatures like hot beverages (coffee). There is, for that reason, room for improvement.

The main design project is a tray with capacity for 6 cups. The cups are made out of our composite (preferably 40% coffee grounds waste), as well as the two side bases/handles. The tray platform is made out of light wood to introduce some contrast to the set. The cups may then be used for all kinds of cold beverages, desserts, condiments, spices, jams. The list is vast, as long as it's nothing hot (temperature wise) (Figure 3). The two side legs/handles are simple structural pieces with an orifice to facilitate handling. These were made to try to demonstrate other uses for the created material, with a higher thickness. The wooden tray has 6 holes for the cups and some geometric cuts at each end to make the joinery with the legs/handles.

Because the experimental work presented such positive results in terms of formulas between coffee waste and PLA, with so many different visual and physical effects, other design possibilities (besides the main project) were thought of, trying to embrace the different potentials offered by the material. Some include the contact with food, others the good relation between coffee waste and plants, and even the effect that some samples have when placed against a light source.



Figure 3. Group of products created with the PLA+coffee waste mixture.

### 2.4 *Bio-valorisation potential of the Portuguese pine resin as matrix of sustainable composites*

This project focused on the creation of proposals for revitalize the use of pine resin, a resource with high potential that is currently underexploited in Portugal. The idea is to take advantage of

this natural resource as an opportunity to integrate matrices of sustainable composites of flax natural fibres, to apply in an ecological product line to promote the Portuguese Design. Due to the fragility characteristic of this resin, experiments were carried out with other materials, so that they can be used as additives to increase rosin plasticity. In this sense, materials from natural and synthetic waste were used, namely: cork powder, rubber granulate, wax, among others.

The traditional pine-tapping is the most common process for obtaining rosin, in which the resin appears naturally in the pine tree to protect and cover the wounds caused by the incisions, being collected and stored in plastic bags or vases (Abad Viñas et al., 2016). The potential for the production of rosin in Portugal is immense, since the pine tree (*Pinus pinaster*) represented in 2010 about 22% of the forest area in the national territory, corresponding to 714,000 hectares (ICNF, 2013). In Portugal, warm temperatures allow each pine to produce, on average, 3 to 4 kg of resin per year (Anastácio and Carvalho, 2008). However, the annual production of resin in Portugal in 2005 was about 5000 tons, and there is currently installed capacity to increase this value considerably, to 20,000 tons (Anastácio and Carvalho, 2008). The applications of the pine resin derivatives are very broad and are mainly used by the processing industries as raw material present in industrial products, pharmaceuticals, and adhesives.

The research began with the preparation of several samples of rosin with each waste individually, varying the proportion of additive between 10% and 50%. Four different additives were considered: cork powder as a waste of natural origin; granulated rubber (particle size < 0.8mm) and wax as wastes of synthetic origin; and EVA (ethylene vinyl acetate) in granules as a virgin material of synthetic origin. In terms of physical resistance, it was possible to see that the combination of pine resin and cork powder was brittle, since more voids were created that contribute to the fragilization of the samples. On the opposite side, the wax waste, when mixed with the pine resin, promoted an increase on samples ductility. However, the use of this feature modifies the original visual appearance of the resin, making it greenish. The processing of rubber granules led to the emission of fumes and odours, proving to be a dangerous and flammable additive. The results with this material were not very positive since the rubber waste granulate did not completely melt with the resin and the original appearance of the rosin changes completely, making the samples black and opaque. The virgin EVA presented itself as the most promising additive, showing complete compatibility with the pine resin, giving more flexibility, especially in the proportion of 30%, without significantly altering their original aspect.

After the research of the material for the composite matrix, pieces of furniture and lighting were designed (Figure 4). The concept consists of semi-structural composite pieces produced in a pine resin matrix with 30% EVA, reinforced by flax fibres. The composite pieces appear attached to complementary pieces produced in cork. The hollow composite part allows for some storage space for objects or a spotlight, so that the bench can be used as a lighting element.

With this work, it was possible to realize that the untapped potential of the Portuguese pine resin can also be considered a waste. The fragility of this natural resource can be improved with the use of natural and synthetic additives and the waste can have great potential as an alternative of less environmental impact. Moreover, since EVA was the only non-waste material, it is possible to carry out future experiments with EVA from shoe soles.



Figure 4. Composition of the concept products idealized to apply the composite material.

### 3 CONCLUSIONS

From these experiences, it was concluded that waste in general is growing and there are no predictions for this growth to slow down. Although there are already waste treatment strategies in

place, if it could be reused, this problem might not exist in a near future. Also, the use of most wastage materials allows for a low-cost approach, making this an unrivalled advantage. For this reason, it becomes apparent that waste really is a good choice for substances to be reused as a material on the creation of design products. It is also obvious that its abundance will continue to exist and designers should see this as an opportunity.

#### 4 FUTURE DEVELOPMENTS OF THE PROJECT

The accomplishment of these research works with positive and promising results, raised a wave of motivation and interest for the use of wastes, entrepreneurially. Thus, in the near future, it is intended to continue the WeWon'tWasteYOU project by creating a social workshop - OFICINA design: School of Social Entrepreneurship – in which teams of designers and engineers will work together with groups of unemployed people. The necessary infrastructures are going to be prepared for this project for the creation of products based on the wastes generated by the local industry. Besides, training courses are going to be made for workers. With this initiative, it is expected to create products in a more sustainable way and appeal to the environment awareness of the society as well as creating more job opportunities for a vulnerable social group.

#### 5 ACKNOWLEDGEMENTS

Authors gratefully acknowledge the funding of Project NORTE-01-0145-FEDER-000022 - SciTech - Science and Technology for Competitive and Sustainable Industries, cofinanced by Programa Operacional Regional do Norte (NORTE2020), through Fundo Europeu de Desenvolvimento Regional (FEDER) and Community Service Engineering European Project (LLP - 539642 - Community Service Engineering).

#### REFERENCES

- ABAD VIÑAS, R., CAUDULLO, G. & DE RIGO, D. 2016. *Pinus pinaster* in Europe: distribution, habitat, usage and threats. European Atlas of Forest Tree Species. Luxembourg: European Commission.
- ANASTÁCIO, D. & CARVALHO, J. 2008. Sector dos Resinosos em Portugal. Evolução e Análise. DGRF, Lisbon.
- BHADA-TATA, Daniel Hoornweg e Perinaz. 2012. "What A Waste - A Global Review Of Solid Waste Management." Urban Development Series knowledge Papers (Nº15):1-116.
- BUREO. Bureo [Online]. Bureo. Available: <http://bureo.co/> [Accessed 30/05/2016].
- ECONYL. Econyl [Online]. Econyl. Available: <http://www.econyl.com/> [Accessed 30/05/2016].
- EUROPEN. Food Waste [Online]. EUROPEN. Available: <http://www.europen-packaging.eu/policy/7-food-waste.html> [Accessed 07/08/2016].
- EUROSTAT. 2017. Generation of waste by waste category, hazardousness and NACE Rev. 2 activity [Online]. Eurostat. Available: [http://appsso.eurostat.ec.europa.eu/nui/show.do?dataset=env\\_wasgen&lang=en](http://appsso.eurostat.ec.europa.eu/nui/show.do?dataset=env_wasgen&lang=en) [Accessed 15/06/2017].
- FAOSTAT. FAOSTAT. Available: <http://faostat3.fao.org/browse/Q/QC/E> [Accessed 28/08/2016].
- ICNF 2013. IFN6-Áreas dos usos do solo e das espécies florestais de Portugal continental. Resultados preliminares. Lisbon: Instituto da Conservação da Natureza e das Florestas.
- INTERNATIONAL NUT AND DRIED FRUIT COUNCIL FOUNDATION 2015. Global Statistical Review 2014-2015. INC.
- ORGANIZATION, I. C. 2015a. The Current State of the Global Coffee Trade [Online]. Available: [http://www.ico.org/monthly\\_coffee\\_trade\\_stats.asp](http://www.ico.org/monthly_coffee_trade_stats.asp) [Accessed 10.12.2015 2015].
- ORGANIZATION, I. C. 2015b. Portugal - Latest facts and figures about the global coffee trade from the International Coffee Organization [Online]. Available: [http://infogr.am/\\_/S268nTQ9nsOy58h5VJZH](http://infogr.am/_/S268nTQ9nsOy58h5VJZH) [Accessed 10.12.2015 2015].
- SHEA, J. 2014. Ghost Fishing Nets: Invisible Killers in the Oceans [Online]. Earth Island Journal Available: [http://www.earthisland.org/journal/index.php/elist/eListRead/ghost\\_fishing\\_nets\\_invisible\\_killers\\_in\\_the\\_oceans/](http://www.earthisland.org/journal/index.php/elist/eListRead/ghost_fishing_nets_invisible_killers_in_the_oceans/) [Accessed 08/03/2016].
- WORLD OCEAN REVIEW. Litter - pervading the ocean [Online]. World Ocean Review. Available: <http://worldoceanreview.com/en/wor-1/pollution/litter/> [Accessed 15/03/2016].

