

REPORTS ON MATHEMATICAL LOGIC
36 (2002), 131–141

Tadeusz Litak

A CONTINUUM OF INCOMPLETE INTERMEDIATE LOGICS

A b s t r a c t. Although in 1977 V.B. Shehtman constructed the first Kripke incomplete intermediate logic, no-one in the known literature has completed his work by constructing a continuum of such logics. After a substantial reminder on how an incomplete logic can be obtained, I will construct a sequence of frames similar to those used by Jankov and Fine. None of these frames can be reduced by a p-morphism to another; at the same time, there are no p-morphisms from generated subframes of the Fine frame onto any frame from the considered sequence. All of the frames satisfy all of Shehtman's axioms. Therefore, by using the characteristic formulas of the frames from the sequence it is possible to obtain the desired conclusion.

In the 1970's, a number of important, deep and technically complicated results concerning relational semantics for modal logics was obtained by such authors as S. Thomason, K. Fine, M.S. Gerson, R.I. Goldblatt, J. F. A. K. van Benthem and W. Blok; it was the Golden Age of the subject, see [1], [2], and [3] for references and summaries of the most important works.

Received 13 January 2002

This article is based on a paper delivered at the 4th International Tbilisi Symposium on Language, Logic and Computation (September 2001).

The main goal of my paper is to draw attention to the fact that many important results lack superintuitionistic analogues, although the task of transferring them is highly nontrivial.

This gap may be partially due to the fact that Kripke semantics never became as popular in the realm of intermediate logics as they are in the realm of modal logics, which are more suitable and flexible tools to deal with frames. There were fewer experts working on relational semantics for intuitionistic logics. In 1977, one of the most distinguished persons in the field, V. B. Shehtman, constructed the first Kripke incomplete intermediate propositional logic. His construction was based mainly on a frame from [5], but he very ingeniously used a formula introduced in [6]. Nevertheless, he did not follow Fine's suggestion that it seems to be possible to construct a continuum of incomplete logics. Such a continuum of $S4$ logics was presented in [10] in the same year as Shehtman's construction; it is known, however, that the incompleteness of a modal logic does not imply the incompleteness of its intuitionistic equivalent. In [9] one may find the claim that there exists a continuum of incomplete predicate superintuitionistic logics. Unfortunately, this claim is given without proof; besides, it is far easier to construct an incomplete predicate superintuitionistic logic than to construct an incomplete propositional superintuitionistic logic. It is truly surprising but up to this day no-one has presented a proof that there exists a continuum of such logics. I shall attempt to fill in this gap.

In this paper I shall try to conform to the standard definitions and symbols which may be found, for example, in a monograph by Chagrov & Zakharyashev [3]. Nevertheless, for the sake of convenience, let me remind the most standard ones. Unless otherwise stated, by a logic I shall mean a superintuitionistic (intermediate) logic.

Definition 1. A (*Kripke*) *structure/frame* consists of a set and a relation of partial order $\mathcal{F} = \langle W, \leq \rangle$.

Definition 2. A *substructure/subframe* of a structure $\mathcal{F} = \langle W, \leq \rangle$ is a frame $\mathcal{G} = \langle V, \leq_1 \rangle$ where $V \subseteq W$ and $\leq_1 = V^2 \cap \leq$.

Definition 3. A (*Kripke*) *model* is an ordered pair $\mathcal{M} = \langle \mathcal{F}, \mathcal{B} \rangle$ consisting of a frame $\mathcal{F} = \langle W, \leq \rangle$ and a function \mathcal{B} from the set of propositional variables to the set of upward closed subsets of W . Valuation is extended to all formulas in the usual way.

I would like now to introduce two technical notions, weaker than *finite approximability* (*finite model property*) and stronger than *completeness*

Definition 4. A logic is *fa-approximable* iff the set of its theorems coincides with the set of all formulas which are true in some class of rooted frames with no infinite antichains.

Definition 5. A logic is *ac-approximable* iff the set of its theorems coincides with the set of all formulas true in some class of frames with no infinite ascending chains — Chagrov & Zakharayashev call such orders *Noetherian*.

Professor A. Wroński has suggested that fa-approximability implies ac-approximability. This would give rise to the following picture:

$$\begin{array}{c} \text{finite approximability} \Rightarrow \text{fa-approximability} \Rightarrow \text{ac-} \\ \text{approximability} \Rightarrow \text{completeness.} \end{array}$$

In my paper, I shall prove that there exists a continuum of propositional logics even outside the broadest class, i.e. the class of all complete logics. Nevertheless, first let me describe how an incomplete logic can be obtained — it is an easy generalization of Shehtman's method [11].

Theorem 1. *A logic L lacks ac-approximability iff its modal companion above \mathbf{Grz} τL is incomplete.*

Proof. It is enough to recall that \mathbf{Grz} is complete with respect to all partial orders without infinite ascending chains. ■

Theorem 2. *If there exists a rule of the form*

$$\frac{(\psi \vee (\psi \rightarrow e(\chi))) \rightarrow \chi}{\chi}$$

(e is any uniform substitution) which is not admissible in some intermediate logic, then this logic lacks ac-approximability and thus lacks the finite model property.

Proof. (sketch) In any family of frames adequate for the logic (if there exists such) there must be a frame validating

$$(\psi \vee (\psi \rightarrow e(\chi))) \rightarrow \chi$$

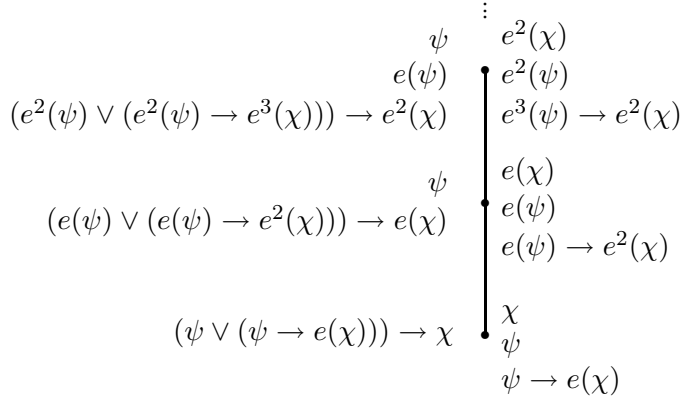

Figure 1: A model refuting χ but verifying $\psi \vee (\psi \rightarrow e(\chi)) \rightarrow \chi$

with all substitutions (because the formula belongs to the logic) and refuting χ under some valuation. It can be easily seen that such a frame must contain an infinite ascending chain — see figure 1. ■

Corollary 3. *If an intermediate logic satisfies the assumptions of theorem 2, then its companion above **Grz** is incomplete.*

Proof. A consequence of theorems 1 and 2. ■

In fact far more can be proved about such a logic — see my forthcoming paper [8].

Theorem 4. *If there exists a rule of the form*

$$\frac{\begin{array}{c} (\psi \vee (\psi \rightarrow e(\chi))) \rightarrow \chi \\ \psi \leftrightarrow \varsigma \rightarrow \tau \\ \tau \rightarrow e(\tau) \end{array}}{\chi}$$

*which is not admissible in a logic L , then in any class of frames adequate for L (if there exists any) there must be a structure containing an infinite comb or a willow (see fig. 2) as a substructure; thus, L must lack both *ac*-approximability and *fa*-approximability.*

Proof. Similar to the proof of theorem 2 — see fig. 4. ■

Let me recall the celebrated Gabbay-de Jongh axioms [6]

$$\mathbf{bb}_n := \bigwedge_{i=0}^n ((p_i \rightarrow \bigvee_{j \neq i} p_j) \rightarrow \bigvee_{j \neq i} p_j) \rightarrow \bigvee_{i=0}^n p_i \quad (n \geq 1)$$

which are complete with respect to the class of all finite frames of branching n . It is well known that they can be refuted in the infinite comb. Nevertheless, not every frame containing the infinite comb as a substructure refutes these axioms — see figure 3. Therefore the following theorem is nontrivial:

Theorem 5. *If there exists a rule of the form*

$$\frac{\begin{array}{c} (\psi \vee (\psi \rightarrow e(\chi))) \rightarrow \chi \\ \psi \leftrightarrow \varsigma \rightarrow \tau \\ \varsigma \vee \tau \rightarrow e(\varsigma) \wedge e(\tau) \\ \chi \leftrightarrow \psi \vee e(\tau) \end{array}}{\chi} \quad (1)$$

which is not admissible in some intermediate logic L , then in any class of frames adequate for L (if there exists any) there must exist a structure refuting $\mathbf{bb}_n (n \geq 2)$. Thus, if L contains any of Gabbay-de Jongh axioms, it must be incomplete.

Proof. It may be carried out in a manner similar to that of Shehtman [11], but it is needlessly complicated, e.g. with a superfluous use of transfinite induction. Therefore I would like to sketch a more elegant and intuitive proof. Assume then that there is a frame \mathcal{F} for L , a valuation \mathcal{V}

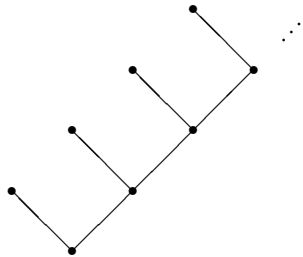

Figure 2: An infinite comb

and a point x in \mathcal{F} such that $x \not\equiv_{\mathcal{V}} \chi$. It is easy to check that x must be the root of the submodel of $\langle \mathcal{F}, \mathcal{V} \rangle$ depicted by picture 4. Now let me define a new valuation \mathcal{B} based on \mathcal{V} and inspired by figure 4:

$$\begin{aligned} \mathcal{B}(p_0) &:= \bigcup_{n=3m} \mathcal{V}(e^n(\zeta)) \wedge \bigwedge_{k=0}^{n-1} e^k(\chi) \cup \bigcap_{n \in \omega} \mathcal{V}(e^n(\psi)), \\ \mathcal{B}(p_1) &:= \bigcup_{n=3m+1} \mathcal{V}(e^n(\zeta)) \wedge \bigwedge_{k=0}^{n-1} e^k(\chi) \cup \bigcap_{n \in \omega} \mathcal{V}(e^n(\psi)), \\ \mathcal{B}(p_2) &:= \bigcup_{n=3m+2} \mathcal{V}(e^n(\zeta)) \wedge \bigwedge_{k=0}^{n-1} e^k(\chi) \cup \bigcap_{n \in \omega} \mathcal{V}(e^n(\psi)). \end{aligned}$$

Axioms of L and figure 4 assure us that sets $\mathcal{B}(p_0)$, $\mathcal{B}(p_1)$ and $\mathcal{B}(p_2)$ are distinct and non-empty. It is easily seen that the consequent of \mathbf{bb}_2 is refuted at x under the valuation \mathcal{B} . Now suppose that there is some $y \geq x$ such that some conjunct of the premise of \mathbf{bb}_2 is *classically* refuted at y , e.g. $y \vDash_{\mathcal{B}} p_0 \rightarrow p_1 \vee p_2$ and $y \not\equiv_{\mathcal{B}} p_1 \vee p_2$. If there is some $n \in \omega$ such that $y \vDash_{\mathcal{V}} e^n(\zeta)$ then by the axioms of L $y \vDash_{\mathcal{V}} e^m(\chi)$ for any $m \leq n$ and $y \vDash_{\mathcal{B}} p_0 \vee p_1 \vee p_2$, which leads to an immediate contradiction. Hence for no $n \in \omega$, $y \vDash_{\mathcal{V}} e^n(\zeta \vee \tau)$. But now there must be some $n \in \omega$ such that $y \not\equiv_{\mathcal{V}} e^n(\psi)$ (otherwise $y \in \bigcap_{n \in \omega} \mathcal{V}(e^n(\psi))$). Hence $y \not\equiv_{\mathcal{V}} e^n(\chi)$ and it is possible to construct an infinite comb similar to the one in figure 4 whose root is y . But it is easy to find some point from this comb which belongs to $\mathcal{B}(p_0)$ and does not belong to $\mathcal{B}(p_1 \vee p_2)$. ■

It may be worth mentioning that rule 1 is as a matter of fact inspired

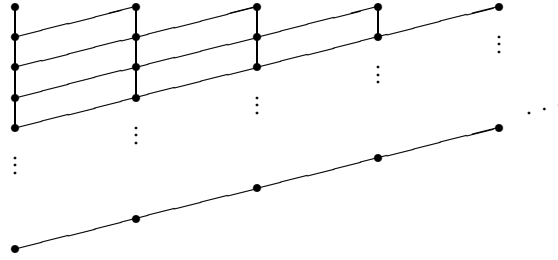

Figure 3: A structure containing an infinite comb as a substructure where Gabbay-de Jongh axiom \mathbf{bb}_2 is true

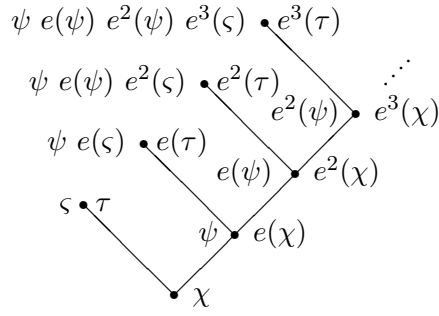

Figure 4: A submodel of $\langle \mathcal{F}, \mathcal{V} \rangle$ whose root refutes χ .

by the form of axioms in Shehtman's later paper [12]. In his paper from 1977 [11] the axioms were more complicated and to make Shehtman's 1977 theorem a consequence of theorem 5 — as I am going to do — rule 1 should be replaced by the following one:

$$\begin{array}{c}
 (\psi \vee (\psi \rightarrow e(\chi))) \rightarrow \chi \\
 \psi \leftrightarrow \varsigma \rightarrow \tau \\
 \tau \rightarrow e(\tau) \\
 \chi \leftrightarrow \psi \vee e(\psi) \\
 e(\psi) \rightarrow \psi \vee e(\tau) \\
 \hline
 \chi
 \end{array} \tag{2}$$

Now let me consider a family of formulas introduced by Shehtman:

$$\begin{array}{ll}
 \beta_{-1} := p, & \gamma_{-1} := q, \\
 \beta_0 := q \rightarrow p, & \gamma_0 := p \rightarrow q, \\
 \beta_{n+1} := \gamma_n \rightarrow \beta_n \vee \gamma_{n-1}, \\
 \gamma_{n+1} := \beta_n \rightarrow \gamma_n \vee \beta_{n-1}, \\
 \alpha_n := \beta_{n+2} \wedge \gamma_{n+2} \rightarrow \beta_{n+1} \vee \gamma_{n+1} \quad (n \in \omega), \\
 \eta := \alpha_0 \rightarrow \alpha_1 \vee \alpha_2, \quad \epsilon := \alpha_0 \vee \alpha_1, \\
 \delta := \eta \rightarrow \epsilon, \quad \kappa := \alpha_1 \rightarrow \alpha_0 \vee \beta_2.
 \end{array}$$

If ς stands for $\beta_2 \wedge \gamma_2$, τ stands for $\beta_1 \vee \gamma_1$ and e is defined as follows:

$$e(p) := q \vee (q \rightarrow p), \quad e(q) := p \vee (p \rightarrow q),$$

then the following observation allows me to use a variant of theorem 5 concerning rule 2

α_0	is of the form ψ , i.e.	$\varsigma \rightarrow \tau$,
ϵ	is of the form χ , i.e.	$\psi \vee e(\psi)$,
δ	is equivalent to	$(\psi \vee (\psi \rightarrow e(\chi))) \rightarrow \chi$,
κ	intuitionistically implies	$e(\psi) \rightarrow \psi \vee e(\tau)$,
$\tau \rightarrow e(\tau)$	is an Int -tautology.	

Of course, it would also be possible to use theorem 5 without any modification. In this case one should define ϵ as $\alpha_0 \vee \beta_2 \vee \gamma_2$ or even $\alpha_0 \vee \beta_2$, δ as $(\alpha_0 \rightarrow \alpha_1 \vee \beta_3) \rightarrow \alpha_0 \vee \beta_2$ and no κ is needed at all. Nevertheless, I am going to stick to the first paper of Shehtman to make references easier; the paper from 1980 [12] is less known.

Lemma 6. *Axioms δ and κ are true in a structure known as the Fine frame (see figure 5). Axiom \mathbf{bb}_n is true in a general frame based on the Fine frame and generated by the two upward closed singletons. The same general frame refutes axiom ϵ .*

Proof. It is quite easy and may be found, for example, in [11]. ■

Corollary 7 (Shehtman). *An intermediate logic L determined by axioms δ , κ , and \mathbf{bb}_2 is incomplete.*

Proof. A consequence of theorem 5 and lemma 6. ■

Now I may construct a continuum of incomplete logics inspired by ideas from Kit Fine's classical papers [4], [5]. I will construct a sequence of frames \mathcal{F}_n (see fig. 6) very similar to the sequence from [4].

Lemma 8. *For any $n \in \omega$, $\mathcal{F}_n \models \delta \wedge \kappa \wedge \mathbf{bb}_2$. Besides, $\mathcal{F}_n \models \epsilon$.*

Proof. The fact that the Gabbay-de Jongh axioms are true in all of those frames is obvious. It is impossible to simultaneously refute α_0 and α_1 in any of the frames, which implies that $\mathcal{F}_n \models \delta \wedge \epsilon$. The validity of κ may be shown in the same way as in case of the Fine frame. ■

Lemma 9. *For any $n \in \omega$, there exists no p -morphism from any generated subframe of \mathcal{F}_n onto \mathcal{F}_m ($m \neq n$). In other words,*

$$\mathcal{F}_n \not\models \beta^\#(\mathcal{F}_m, \perp)(m \neq n),$$

where $\beta^\#(\mathcal{F}_m, \perp)$ is a Jankov formula for \mathcal{F}_m .

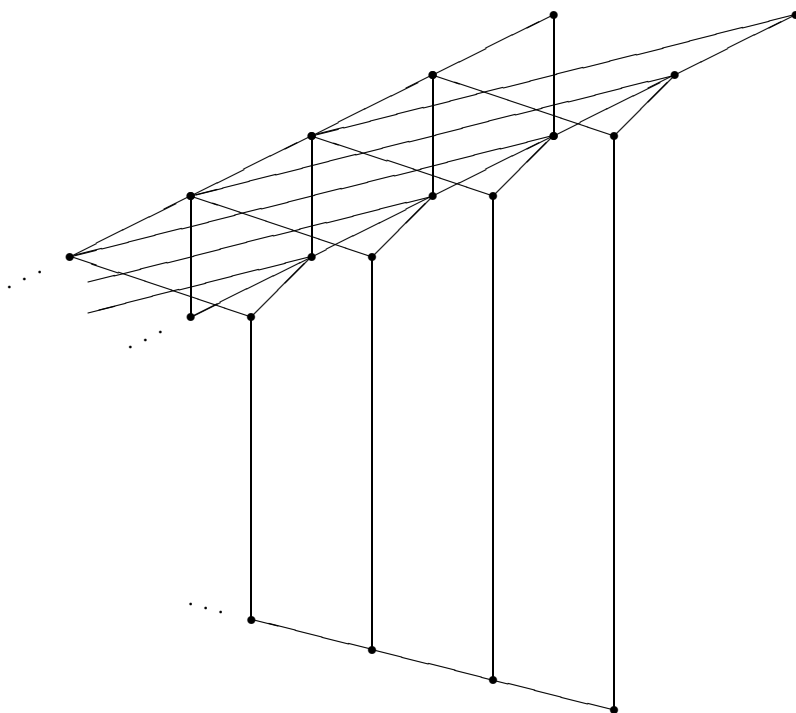

Figure 5: The Fine frame

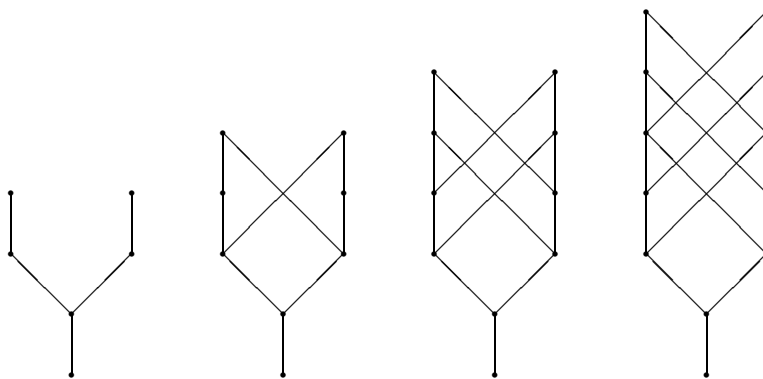

Figure 6: Frames $\mathcal{F}_0, \mathcal{F}_1, \mathcal{F}_2, \mathcal{F}_3$

Proof. It is similar to the one in [4] (by induction). ■

Lemma 10. *For any $n \in \omega$, there exists no p -morphism from any generated subframe of the Fine frame onto \mathcal{F}_n . In other words, Jankov formulas for the entire sequence are satisfied in the Fine frame.*

Proof. As above. ■

Theorem 11. *Distinct subsets of natural numbers generate distinct intermediate logics whose axioms are δ , κ , \mathbf{bb}_2 and the Jankov formulas of those frames from the sequence whose indices belong to a given subset of ω . All of these logics are incomplete.*

Proof. The fact that these logics are all distinct is a consequence of lemmas 8 and 9. The fact that these logics are incomplete follows from theorems 5 and lemmas 6 and 10 — a suitable inference rule is not admissible in any of the logics. ■

I would like to thank Professor A. Wroński, the supervisor of my master's thesis, for his constant help and advice.

References

- [1] R.A. Bull, *Review*, Journal of Symbolic Logic, **47** (1982), pp.440-445.
- [2] R.A. Bull, *Review*, Journal of Symbolic Logic, **48** (1983), pp.488-495.
- [3] A.V. Chagrov and M.V. Zakharyashev, *Modal Logic*, Clarendon Press, Oxford 1997.
- [4] K. Fine, *An Ascending Chain of S4 Logics*, Theoria, **40** (1974), pp.110-116.
- [5] K. Fine, *An Incomplete Logic Containing S4*, Theoria, **40** (1974), pp.23-29.
- [6] D.M. Gabbay and D.H.J. de Jongh, *A Sequence of Decidable Finitely Axiomatizable Intermediate Logics with the Disjunction Property*, Journal of Symbolic Logic, **39** (1974), pp.67-78.
- [7] V.A. Jankov, *Constructing a Sequence of Strongly Independent Superintuitionistic Propositional Calculi*, Soviet Mathematics Doklady, **9** (1968), pp.806-807.
- [8] T. Litak. *Incompleteness revisited*, Forthcoming.
- [9] H. Ono, *A Study of Intermediate Predicate Logics*, Publ. RIMS, Kyoto University, **8** (1972/73), pp.619-649.
- [10] V.V. Rybakov, *Noncompact Extensions of the Logic S4*, Algebra and logic, **16** (1977), pp.321-334.

- [11] V.B. Shehtman, *On Incomplete Propositional Logics*, Soviet Mathematics Doklady, **18** (1977), pp.985-989.
- [12] V.B. Shehtman, *Topological models of propositional logics*, Semiotics and Information Science, **15** (1980), pp.74-98. (Russian)

Department of Logic
Jagiellonian University
Grodzka 52
31-044 Cracow

tlt@konto.pl