

APPLICABILITY OF THE SILVER AMALGAM ELECTRODE IN VOLTAMMETRIC DETERMINATION OF ZINC AND COPPER IN GASTRIC JUICE AND GASTRIC MUCOSA OF RATS

WŁODZIMIERZ OPOKA^{1*}, BOGUSŁAW BAŚ², WITOLD RECZYŃSKI², MAŁGORZATA PŁONKA³,
DANUTA DROZDOWICZ⁴, ZBIGNIEW ŚLIWOWSKI⁴ and TOMASZ BRZOZOWSKI⁴

¹Department of Inorganic Chemistry, Faculty of Pharmacy, Jagiellonian University Medical College,
9 Medyczna St., 30-688 Kraków, Poland

²Department of Analytical Chemistry, Faculty of Material Science and Ceramics, AGH University of
Science and Technology, 30 Mickiewicza Av., 30-059 Kraków, Poland

³Department of Physiotherapy, University School of Physical Education,
78 J. Paul II Av., 31-571 Kraków, Poland

⁴Department of Physiology, Jagiellonian University Medical College,
16 Grzegórzecka St., 31-531 Kraków, Poland

Abstract: The aim of the work was to compare two analytical methods of trace analysis in respect to their applicability in heavy metals determination in biological samples. Atomic absorption spectrometry (AAS) may be considered as the method of choice in such analyses due to its accuracy, precision and low detection limit. On the other hand, voltammetric methods seem to be as useful, but rarely applied. Having in mind that there is no universal analytical method, we have compared two AAS and voltammetric methods as the tools for Zn and Cu determination in the samples collected from rat gastric juice and gastric mucosa. Construction of the renewable silver amalgam film electrode (Hg(Ag)FE) for stripping voltammetry was described. Detailed optimization of measurements procedure and sample preparation for differential pulse anodic stripping voltammetry (DP ASV) and AAS were also performed and presented. The obtained results of quantitative analysis of the chosen parameters by means of both methods are discussed.

Keywords: zinc, copper, gastric mucosa, gastric juice, amalgam film electrodes, stripping voltammetry, atomic absorption spectrometry

Zinc is important for body metabolism, growth, gastric acid secretion, reduction and tissue healing, it activates about 300 enzymes (1–3) but the precise mechanism of Zn²⁺ containing compounds affecting mucosal integrity, gastroprotection and ulcer healing remains unclear. It is confirmed that zinc affects healing of damage of various tissues (4). In many experiments it was shown that gastric damage induced in laboratory animals by various means such as ethanol, steroidal agents, strong acids (5–8) and stress (9, 10) can be treated using zinc-containing remedies. Therefore, it was concluded that zinc exhibits protective properties and could be used in the treatment of inflammation in various form of gastrointestinal injury under different experimental conditions (11, 12). Zinc deficit in serum and gastric

mucosa was reported to delay ulcer healing but the mechanism of this action of zinc preparation has not been fully clarified. The studies in animals and humans confirmed that zinc possesses, so called, “cytoprotective” properties (13).

Similarly, the anti-inflammatory action of copper complexes seems to contribute to their anti-ulcer effect. Part of the protective and anti-ulcer mechanism could be attributed to absorption and transport of copper that seems to be involved in an activation of the several copper-dependent enzymes (14–16). It has been confirmed that copper nicotinate exhibits a gastroprotective action against formation of gastric lesions (17).

Trace elements ions such as Zn²⁺ and Cu²⁺ could be successfully measured in the gastric juice

* Corresponding author: e-mail address: mfopoka@cyf-kr.edu.pl

and gastric mucosa during ulcer healing. Compounds chelating of Zn^{2+} and Cu^{2+} can exert beneficial influence on the ulcer healing possibly *via* Zn^{2+} and Cu^{2+} mediated increase in gastric microcirculation but their antisecretory activity and the effect on gastrin release, which may exert trophic action on gastric mucosa with ulcer, remain unknown.

Important methods of analyzing heavy metals are mainly based on the use of graphite furnace atomic absorption spectrometry (GF-AAS) (18), the direct flame atomic absorption spectrometry (F-AAS) (19), inductively coupled plasma mass spectrometry (ICP-MS) (20) or inductively coupled plasma optical emission spectroscopy (ICP-OES), neutron activation analysis (NAA) (21) and X-ray fluorescence analysis (22). However, these spectrometric methods are expensive, and not suitable for the *in situ* measurement and reliable measure of total metal ion concentrations, and provide no information regarding the concentration of metals in a sample that might interact with a biological molecules or species.

An alternative to these spectroscopy techniques is electro-analytical technique – voltammetry. Voltammetry is certainly a valid analytical technique, very simple and suitable for metals determination in multicomponent complex matrices. Voltammetric methods are widely applied in biomedical and pharmacological analysis (23, 24) as well as in analysis of metals (25–27). Differential pulse voltammetry (DPV) is considered a convenient method because of the wide range of linearity, excellent reproducibility, low experimental cost and the attainment of low detection limit. Stripping voltammetry (SV) comprises a variety of electrochemical approaches, having a step of preconcentration onto the electrode working prior to the voltammetric measurement. The major advantage of SV compared with direct voltammetric measurement is the preconcentration factor. In trace analysis of heavy metal ions, anodic stripping voltammetric (ASV) is the most popular SV technique (28, 29). Moreover, such a technique may be a good alternative to spectroscopy, which, in the case of determination of metal species, metals in complex matrices, needs expensive equipment. However, organic constituents in the sample matrix often passivate electrodes and prevent direct determination (30), such that either the use of mercury is required and/or a sample pre-treatment may need to be performed. For example, Tripathi et al. (31) have quantified zinc in infants using ASV with the use of a hanging mercury drop electrode (HMDE) and with complementary AAS. While it has been shown that ASV and poten-

tiometric-stripping analysis (PSA) was possible in whole blood samples (32), a time-consuming sample digestion was required (ca. 3.5 h) greatly reducing the attraction of this method as an analytical protocol. It is clearly evident from the literature that a rapid and sensitive electrochemistry protocol is required for the determination of metal species in clinical samples.

The sensitive determination of zinc and copper traces is quite simple by ASV equipped with HMDE. However, the toxicity of mercury limits the usage of the mercury electrodes in the analytical practice. The essential group of electrodes used nowadays in voltammetry measurements are film electrodes. There are two types of such electrodes: mercury film electrodes (MFEs) (33) and bismuth film electrodes (BiFEs) (34). Film electrodes are characterized by high sensitivity and repeatability. The MFEs, due to their large surface-to-volume ratio, give sharper stripping peaks and therefore enhanced sensitivity (35). One of the alternatives to mercury are liquid and solid amalgams (36). The problem of limiting the amount of mercury or its soluble salts used to generate MFEs needed for the analytical procedure can be solved with the help of a renewable silver amalgam film electrode (Hg(Ag)FE). The principle of working and first proposal of a construction of the (Hg(Ag)FE) was described in (37). In this work, Hg(Ag)FE was proposed as a working electrode for voltammetric determination of Zn and Cu in gastric juice and gastric mucosa of rats.

EXPERIMENTAL

Measuring apparatus and software

An Electrochemical Analyzer M161 (MTM-ANKO, Poland) was used in this study. The classical three-electrode quartz cell of 10 mL volume, consisting of a homemade renewable silver amalgam film electrode (Hg(Ag)FE), with a surface area of 1–12 mm², as the working electrode, a double junction reference electrode Ag/AgCl/3M KCl and a platinum wire as an auxiliary electrode. All solutions used for analyses were purged with argon of 99.995% purity. Magnetic Teflon-coated bar was used for stirring (approx. 500 rpm) during the accumulation period. The MTM-ANKO *EAGRAPH* software enabled electrochemical measurements, data acquisition and advanced processing of the results (38–40). For spectroscopic determination of Zn and Cu, the Perkin Elmer spectrometer Model 3110 (USA) was used. Liquid samples were digested using a UV-digester (Mineral, Poland). Solid

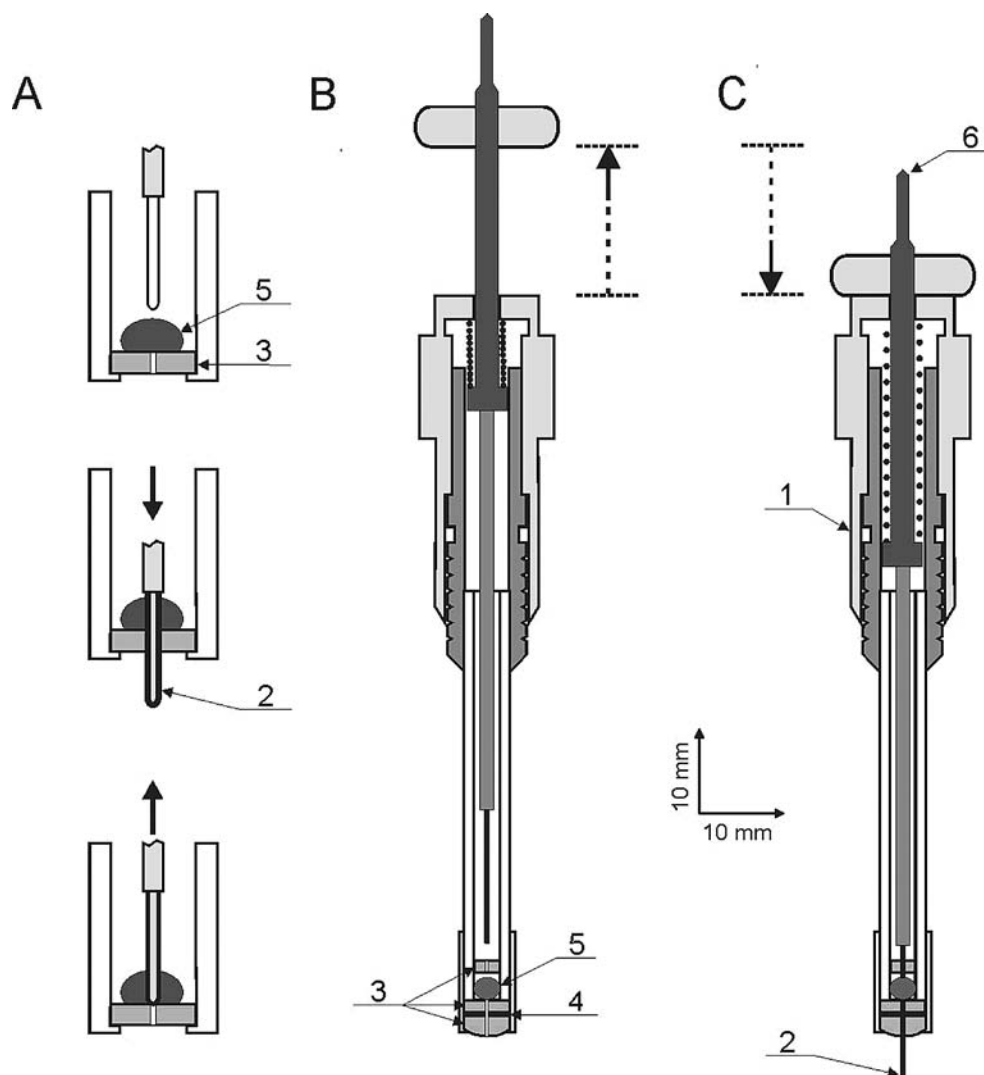

Figure 1. (A) The principle of mechanical refreshing of the liquid amalgam film silver based electrode. The Hg(Ag)FE used in our experiments: (B) configuration before use, (C) configuration ready for measurement. (1) micrometric screw, (2) piston pin with Ag cylindrical electrode at the end, (3) O-ring, (4) Ag foil (0.05 mm), (5) liquid silver amalgam (10 μ L), (6) electric contact pin

materials were digested in a microwave digestion system Anton Paar Multiwave 3000 (Switzerland). All experiments were carried out at room temperature.

Chemicals and glassware

All used reagents were of analytical grade. All solutions and the sample preparation were made using 4-fold distilled water (two last stages from quartz). HNO₃ 65%, H₂O₂ 30% and KNO₃ (Merck, Suprapur®) were used for the preparation of sam-

ples and supporting electrolyte. The standard solution of zinc(II) and copper(II) were at a concentration of 1000 mg/L (Merck). Solutions with lower zinc and copper concentrations were made weekly by appropriate dilution of the stock solution. Fumed silica of the specific surface area 255 m²/g (Sigma-Aldrich) was activated by roasting for 30 min at 950°C. Prior to use, all glassware and, if necessary, also the electrode body, were cleaned by immersion in a 6 M nitric acid, followed by copious rinsing in distilled water to avoid contamination.

Construction of the renewable silver amalgam film electrode, Hg(Ag)FE

The preparation and construction of the renewable (Hg(Ag)FE) were described in details (41, 42). The construction of the applied electrode that allows the liquid amalgam film to be refreshed before each measurement, a procedure essential for its performance, is given in Figure 1. Figure 1A presents how the film electrode is refreshed, whereas Figures 1B and 1C show the construction of the electrode used throughout the experiments.

The micrometric screw /1/ allows the precise setting of the part of the electrode surface /2/ that is in contact with the sample solution. Rotating the screw by a full 360° changes the area of electrode surface by 1.8 mm². The O-ring seals /3/ made from silicon rubber, separated by a 0.05 mm thick silver foil /4/ used to remove any possible mechanical contamination, overlap the amalgam layer /5/ and remove the excess liquid amalgam. The procedure of refreshing the outer amalgam film involves two steps: (a) pulling up the silver electrode base inside the electrode body, through the amalgam chamber (Fig. 1B) and then (b) pushing it back outside the electrode body (Fig. 1C). The total volume of the liquid silver amalgam used to fill up the chamber does not exceed 10 µL. The most recent version of amalgam film electrode applied for measurements is shown in Fig. 1B, which presents the electrode configuration before the electrochemical experiment. The electrode is in operation when the silver cylinder is moved down and immersed in the solution. Figure 1C shows the Hg(Ag)FE ready for measurements.

Standard procedure of measurements

The stripping was performed in the differential pulse (DP) mode. Before measurements, the voltammetric cell was conditioned in 0.1 M nitric acid, rinsed with distilled water and shortly conditioned in supporting electrolyte (0.1 M KNO₃). Next, 5 mL of 0.05 M KNO₃ was added in the electrochemical cell as a blank and the solution was purged with argon for at least 5–7 min. A potential of -0.10 V was applied to conditioning the electrode. The accumulation step (time and potential) was carried out from the stirred solution for a period of $t_{acc} = 30$ s at an $E_{acc} = -1.10$ V. After a rest period of 5 s, DP voltammogram was recorded in the anodic direction from -1.10 to 0.15 V with a potential scan rate of 25 mV/s and pulse amplitude of -30 mV. The voltammogram for the blank solution demonstrates electrochemical cell and supporting electrolyte purity. Then, 0.05–0.20 mL of sample solution was added to the

cell while maintaining an argon atmosphere over the solution and the DP voltammograms were recorded. The total analytical procedure consists in carrying out two steps in succession. In the first step, zinc is determined in the range -1.10 to -0.70 V ($E_{acc} = -1.10$ V, $t_{acc} = 30$ s). In the second step, copper concentration is measured in the range -0.25 to 0.15 V ($E_{acc} = -0.25$ V, $t_{acc} = 30$ s). The quantitative determinations of zinc and copper ions were performed using the standard additions method (three concentrations). Three curves were recorded and averaged for each concentration.

The peak current value, relevant to each addition, is plotted on the y-axis, while the x-axis is graduated in terms of the amount of analyte added. The regression line is calculated and extrapolated back to the point on the x-axis at which $y = 0$. It is clear that this negative intercept on the x-axis corresponds to the amount of the analyte in the test sample. It is important to highlight that such a method shows a particular advantage: the regression analytical calibration function does not present matrix effects. Because of very complicated background in these experiments, baseline correction algorithm should be applied to obtain high quality calibration model (43, 44). All samples were measured under the same conditions.

Sample preparation

Experiments were performed on 15 male Wistar rats weighing 200–250 g. The animals have been divided into two groups. Group A ($n = 6$) consisted of animals with operationally implanted metal gastric fistula measuring gastric juice (GJ) secretion and group B ($n = 9$) with gastric mucosa (GM) of animals without fistula. The procedure of implanting the metal cannula into the gastric wall had been conducted 14 days before the start of study. The animals have been fed with standard granulated mass including indispensable nourishment components, they have had free access to water and they have stayed in a well-lit room with access to fresh air. The animals were housed in a temperature of $22 \pm 1^\circ\text{C}$.

The content of zinc and copper ions in GJ has been studied in rats of group A and in GM in group B. Before testing, all animals were food fasted for 24 h with access to water *ad libitum*. The animals were sacrificed and their stomachs were removed rapidly, opened along the lesser curvature, and washed in physiological saline and gastric tissue samples were taken for determination of zinc and copper concentrations. Tissue samples from each animal have been put in Eppendorf tubes, frozen and kept at -80°C until analysis.

All experimental procedures were approved by the Experimental Animal Research Committee of the Jagiellonian University Medical College.

Gastric mucosa (GM)

For DP ASV zinc and copper determination in GM, about 50 mg of dried sample was weighed and transferred into a high pressure PTFE container and treated with 4 mL of HNO₃ and 2 mL of H₂O₂ (30%). The container was then placed into a microwave oven. Digestion of the samples was carried out with the following program: 20 min under microwave irradiation 45 min cooling time, 5 min waiting time. Digested samples were placed on a heated plate in order to evaporate the excess of reagents. The sample solutions were cooled to room temperature and transferred quantitatively into volumetric flasks (5 mL) and filled up to the mark with 4-fold distilled water.

Gastric juice (GJ)

GJ samples were acidified with nitric acid immediately after collection by addition of 2 µL HNO₃ (conc.) to each 20 µL of sample. The pretreatment, intended to destroy organic compounds (complexing agents and organic surfactants), followed the wet ashing method used in the ASV determination of Zn²⁺ and Cu²⁺ in GJ. Then, samples were transferred directly into a miniature quartz tube and were digested by UV irradiation for 2 h. The quartz tubes were let to cool at room temperature. Aliquots of 0.2–0.5 mL of this solution were introduced into the electrochemical cell containing the supporting electrolyte.

The application of fumed silica

Interfering organic substances might be removed from the analyzed liquid samples not only by means of digestion, but also by their adsorption on fumed silica. First Kowalski et al. (45) have proposed an effective method of voltammetric measurements, in which electrolytic process was not disturbed by addition of fumed silica directly to the electrochemical cell. The usefulness of that procedure in elimination of certain interferences in determination of traces of heavy metals was observed earlier and described in our works (46, 47). In this work, organic interfering substances were removed from the samples in two different ways. The first method consisted in preparation of either 5 mL of the supporting electrolyte spiked by the 0.05–0.20 mL of GJ. Then, 25 mg of SiO₂ was added directly to the cell with the sample. The solution was stirred and deaerated with pure argon. Next, the determina-

tions of Zn²⁺ and Cu²⁺ were performed. For volumes of gastric juice higher than 0.1 mL, the samples were initially digested in an UV system. For the samples containing high concentrations of organic compounds, much higher amount of silica was used – up to 50 mg SiO₂ for 1 mL of the analyzed solution. As the addition of such high amount of silica directly to the electrochemical cell is not possible, the second procedure was proposed. To 20 mL of contaminated sample 0.25–1.0 g of fumed silica was added. The suspension was stirred and shaken for 15 min. To separate the fumed silica, the sample was centrifuged for 5–8 min. at 3500 rpm. An appropriate volume of the supernatant, free of organic interfering substances, was then added to the cell containing the supporting electrolyte. The Zn²⁺ and Cu²⁺ determination were performed in standard conditions.

RESULTS AND DISCUSSION

Characteristic features of the Hg(Ag) film electrode

The Hg(Ag)FE maintain its perfect repeatability and reproducibility for 2–3 thousand cycles under condition that: a) for the Hg(Ag)FE preparation, silver of fibrous texture is used, b) for the Hg(Ag)FE regeneration, silver liquid amalgam is used (5). During the performed experiments, the use of silver wire (Goodfellow Science Park, England) ensured the Hg(Ag)FE stability for 6 months of electrode tests. Silver liquid amalgam does not disturb the Hg(Ag)FE surface even though it is exposed to constant contact for several weeks, refreshed in it film does not change its properties for many minutes, and the hydrogen overpotential is comparable to the mercury electrodes. The content of silver in the liquid amalgam was determined using AAS method. When electrode is not renewed before measurement, peak current drops for successive scan about 5%.

Influence of DP ASV parameters on technique on zinc and copper peaks

In order to adapt the DP ASV method to ppb concentrations of Zn²⁺ and Cu²⁺, three parameters were optimized: step potential (E_s), pulse amplitude (ΔE) and pulse time ($t_p = t_w$ (waiting time) + t_s (current sampling time)). To optimize the conditions for Zn²⁺ and Cu²⁺ measurements, the following instrumental parameters were systematically verified: E_s in the range 1–5 mV, ΔE in the range 10–60 mV and t_p from 10 to 50 ms. Changes of the potential step (in the given range) cause the increase on peaks cur-

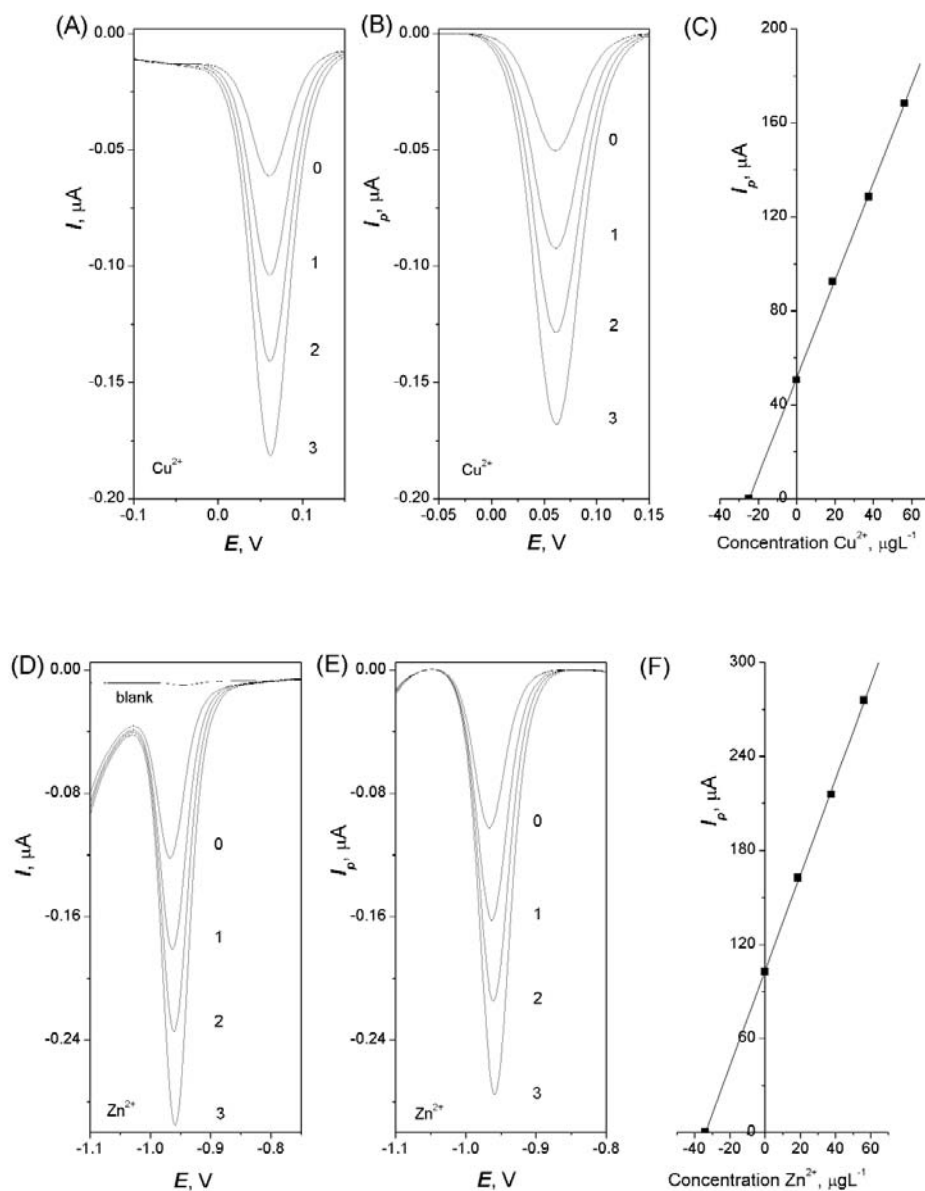

Figure 2. DP ASV determination of (A) Cu²⁺ and (D) Zn²⁺ ions in gastric juice sample using the method of standard addition. Curves: blank; (0) 0.05 mL of the sample and 5 mL 0.05 M KNO₃ with 25 mg fumed silica; (1, 2 and 3) standard addition: 18.8, 37.6 and 56.3 $\mu\text{g/L}$ Cu²⁺ or Zn²⁺. (B) and (E) curves from part (A) and (D) after background correction. (C) and (F) calibration plots for Cu²⁺ and Zn²⁺ ions, respectively. DP mode: potential step, 2 mV; pulse amplitude, -30 mV; pulse width, 40 ms. Condition of electrode positioning: $E_{\text{acc}} = -1.1$ V; $t_{\text{acc}} = 30$ s for Zn²⁺ and $E_{\text{acc}} = -0.25$ V; $t_{\text{acc}} = 30$ s for Cu²⁺

rent by 8–15%. However, increasing E_s is accompanied by the background current rising. Therefore, it is not suggested to apply the $E_s > 2$ mV. The step potential of 2 mV was applied in further work. The

best results (signal-to-background current ratio) were obtained for the pulse amplitude -30 mV (for $t_{\text{acc}} = 30$ s the peak current for 20 $\mu\text{g/L}$ Zn²⁺ and Cu²⁺ were ~61 nA and ~37 nA, respectively). The peaks

Table 1. Concentrations of Zn and Cu in the CRM No. 185, bovine liver determined by means of DP ASV and F-AAS methods (n = 5).

Element concentration	DP ASV	F-AAS
Zn [mg/g] (recovery, %) Certified value: 142 ± 3	139 ± 4 (98)	135 ± 8 (95)
Cu [mg/g] (recovery, %) Certified value: 189 ± 4	187 ± 5 (99)	191 ± 11 (101)

Table 2. Concentrations of Zn and Cu in the rat gastric juice (GJ) samples determined by means of DP ASV and F-AAS methods (n = 5).

Sample number	Zn concentration [mg/L]		Cu concentration [mg/L]	
	DP ASV	F-AAS	DP ASV	F-AAS
1	4.13	4.27	2.80	2.93
2	4.68	4.72	1.68	1.70
3	4.69	4.84	1.37	1.46
4	5.97	6.06	1.28	1.38
5	3.32	3.47	1.71	1.85
6	2.16	2.22	0.77	0.82

Table 3. Comparison of Zn and Cu concentrations in rat gastric juice (GJ) samples with and without digestion (n = 5).

Sample	Zn concentration [mg/L]		Cu concentration [mg/L]	
	Without digestion	Digested	Without digestion	Digested
A	3.69 ± 0.29	3.41 ± 0.17	2.53 ± 0.15	2.57 ± 0.11
B	39.70 ± 2.78	37.46 ± 1.50	1.12 ± 0.08	1.23 ± 0.07

Table 4. Concentrations of Zn and Cu in the rats gastric mucosa (GM) samples determined by means of DP ASV and AAS methods.

Sample number	Zn concentration [mg/g]		Cu concentration [mg/g]	
	F-AAS	DP ASV	ET-AAS	DP ASV
1	13.2	12.9	1.09	0.98
2	14.2	14.3	0.49	0.52
3	14.5	13.6	0.85	0.72
4	12.0	12.2	2.53	2.72
5	12.8	13.3	2.79	2.81
6	12.2	11.8	3.47	2.98
7	14.0	13.4	0.25	0.19
8	14.4	15.9	2.77	2.31
9	13.3	12.7	1.99	2.20

for zinc are narrower and substantially higher than those of copper. The locations of the peaks are independent of concentration of metals. The width of the peak at half-height for Zn^{2+} and Cu^{2+} are 42 ± 2 and 48 ± 2 mV, respectively. The reproducibility is below 2% for the 5–50 $\mu\text{g/L}$ concentration range of both metals. The best results (precision, reproducibility and the signal-to-background current ratio) were obtained for pulse width 40 ms, and this was the value chosen for the further work. In each case, $t_w = t_s$. The height of Zn and Cu peaks strongly decreases with the increasing time t_p but simultaneously the background current decreases.

Influence of the Hg(Ag)FE surface size on zinc and copper peaks

In stripping methods, the peak current is linearly dependent on the surface area of the working electrode. The surfaces of film electrodes are usually much larger than those of mercury drop electrodes. When using the Hg(Ag)FE the surface of the working electrode may easily be varied in a wide range. For a surface area of 1.8 mm^2 , the peak current for 10 $\mu\text{g/L}$ Zn^{2+} was 9 nA and grew linearly as the surface of the working electrode increased in size. For a surface area of 11.5 mm^2 , the peak current of zinc was 56 nA. The parameters of the linear growth of peak current for zinc and copper vs. surface of working electrode are: slope, 0.5 ± 0.02 and 0.3 ± 0.01 [nA/mm^2], and correlation coefficient $r = 0.999$ and $r = 0.997$, respectively. For further study, a 6 mm^2 surface area Hg(Ag)FE was applied.

Effect of accumulation time and potential

The influence of the accumulation potential (E_{acc}) was studied in the range from -1.15 to -0.95 V and -0.35 to -0.15 V with 0.05 M KNO_3 spiked with 20 $\mu\text{g/L}$ Zn^{2+} and Cu^{2+} , respectively. The repeatability and the magnitude of the analytical signal were found to be independent of the accumulation potential in the potential range -1.15 to -1.05 V for zinc and -0.35 to -0.15 V for copper. The accumulation potential -1.15 V and -0.25 V was chosen.

The accumulation time (t_{acc}) was changed from 0 to 120 s. The peaks current for supporting electrolyte containing 20 $\mu\text{g/L}$ Zn^{2+} and Cu^{2+} increased linearly with the accumulation times. For further study, the accumulation time of 30 s was chosen. The zinc and copper peaks potential is not dependent on either the accumulation time and potential.

Calibration graphs

The calibration graph for Zn^{2+} and $t_{acc} = 30$ s was linear from 1 to 100 $\mu\text{g/L}$ and obeyed the equation $y =$

$2.99 \pm 0.87x$ [$\text{nA}/(\mu\text{g/L})$] + 0.18 ± 1.1 [nA]. The correlation coefficient was $r = 0.9997$. The relative standard deviation for Zn^{2+} determination at the concentration 20 $\mu\text{g/L}$ was 1.6% ($n = 5$). The detection limit for Zn^{2+} following the accumulation time of 30 s, calculated as a 3 σ for the blank, was equal to 0.9 $\mu\text{g/L}$.

The calibration graph for Cu^{2+} and $t_{acc} = 30$ s was linear from 2 to 100 $\mu\text{g/L}$ and obeyed the equation $y = 1.86 \pm 0.64x$ [$\text{nA}/(\mu\text{g/L})$] + 0.25 ± 0.8 [nA]. The correlation coefficient was $r = 0.9991$. The relative standard deviation for Cu^{2+} determination at the concentration 20 $\mu\text{g/L}$ was 2.8% ($n = 5$). The detection limit for Cu^{2+} following the accumulation time of 30 s, calculated as a 3 σ for the blank, was equal to 1.4 $\mu\text{g/L}$.

For both metals the detection limit can be decreased further by prolonging the accumulation time. In the tested range, $0 \text{ s} = t_{acc} = 120 \text{ s}$, the relation $I_p - t_{acc}$ is linear, with a sensitivity of ca. 2 nA/s for 20 $\mu\text{g/L}$ Zn^{2+} and 1.3 $\mu\text{A/s}$ for 20 $\mu\text{g/L}$ Cu^{2+} . Moreover, sensitivity might be twice increased by increasing the electrode surface Hg(Ag)FE from 6 to 12 mm^2 . Linearity range (upper limit) is the same for both analyzed metals and is equal to 0.05 $\mu\text{g/L}$.

DP ASV analysis of Cu^{2+} in gastric juice

The GJ sample (0.05 mL) with addition of 5 mL of the supporting electrolyte (0.05 M KNO_3) with 25 mg of SiO_2 was analyzed by DP ASV under the described conditions. The representative voltammetric curves for GJ sample are presented in Figure 2A, B and C.

The shape and width of the peak were similar to that obtained from a synthetic solution. The obtained value of standard (10 $\mu\text{g/L}$), based on three replicates, was 24.9 ± 1.1 $\mu\text{g/L}$ of Cu^{2+} ions. The detection limit for the determination of copper under these conditions was estimated to be 3 $\mu\text{g/L}$ and is limited by the purity of the reagents used in the digestion procedure. The recovery of Cu^{2+} was tested by addition of 20 $\mu\text{g/L}$ of Cu^{2+} . The average recovery was $102 \pm 5\%$. For comparison, the Cu^{2+} concentration in the sample of gastric juice, measured using HMDE was 22.6 ± 2.5 $\mu\text{g/L}$. The Hg(Ag)FE was applied for Cu^{2+} determination in the CRM. The obtained results are presented in Table 1. The results of Cu^{2+} determinations by means of DP ASV method in the rat GJ samples are given in Table 2.

DP ASV analysis of Zn^{2+} in gastric juice

The GJ sample (0.05 mL) with addition of 5 mL of the supporting electrolyte (0.05 M KNO_3) with 25 mg of SiO_2 was analyzed by DP ASV under the described conditions. The representative voltam-

metric curves for GJ sample are presented in Figure 2D, E and F.

The shape and width of the peak were similar to that obtained from a synthetic solution. The obtained value of standard (10 µg/L), based on three replicates, was 35.5 ± 1.6 µg/L of Zn²⁺ ions. The detection limit for the determination of zinc under these conditions was 2 µg/L and is limited by the purity of the reagents used in the digestion procedure. The recovery of Zn²⁺ was tested by addition of 20 µg/L of Zn²⁺. The average recovery was $103 \pm 4\%$. For comparison, the Zn²⁺ concentration in the sample of gastric juice, measured using HMDE was 33.8 ± 2.2 µg/L. The Hg(Ag)FE was applied for Zn²⁺ determination in the CRM. The obtained results are presented in Table 1. The results of Zn²⁺ determinations by means of DP ASV method in the rat GJ samples are given in Table 2.

F-AAS analysis of rat gastric juice samples

Generally, one of the essential conditions referring to the analytical sample is its homogeneity. The gastric juice samples did not fulfill this requirement. So, one should expect that some kind of pretreatment is required. On the other hand, any additional analytical operations may induce errors, resulting from the use of reagents, instruments and may lead to the sample contamination or loss of analyte, not mentioning time and money consumption.

In the first step of the presented method comparison, it was checked whether direct analysis of intact sample is possible. In that step, only AAS was considered as the analytical method. Initial measurements enabled to choose the flame technique (F-AAS) using air-acetylene flame as adequate tool for Zn analysis. Two samples of the sap, differing in Zn concentrations, were prepared by combining 0.5 mL of 6 samples (total sample volume was 3 mL) and digested in four repetitions. For quantitative determination of Zn and Cu, the Perkin Elmer spectrometer Model 3110 (USA) was used. Flame analysis was performed at 213.9 nm, slit 0.7 nm, HCL (Hollow Cathode Lamp). All the measurement parameters (gases flow, burner and lamp position, etc.) were optimized before analysis). Linear range of F-AAS zinc analysis was 0.02–0.75 mg/L; detection limit was 0.02 mg/L. Cu determination was made at 324.8 nm, slit 0.7 nm, HCL. The same optimization procedure for Cu determination was performed. Linear range of copper analysis was 0.10–3.00 mg/L; detection limit was 0.10 mg/L. Under given measurement conditions for Zn and Cu determination by means of F-AAS, the results reported in Table 3 were obtained for the rat GJ samples without and after digestion.

Each value is the average of 4 separate determinations. It is clear that in the case of Cu determination, the obtained values are in very good agreement. In the case of zinc, for both samples a slight loss of the analyte in the digested samples is noted (about 7%). This is connected with the digestion procedure and the volatility of the analyte. What is more, for both elements, analysis of the digested samples gave more precise results. Most probably, although digestion procedure can cause some errors resulting from additional operations, inhomogeneity of raw samples contributes to a decrease of determination precision. Nevertheless, one can accept slightly less precise results in situation when no loss of analyte is expected and analyses might be performed much faster and at lower cost (no need to use an expensive equipment and reagents). In trace analysis, speed is also a factor of interest. However, it should be noted that the possibility of analysis of not treated liquid samples (as it was in the case of rat GJ) should always be considered referring to the analyte and the sample composition.

F-AAS analysis of rat GM

Solid samples (animal or human tissues) analyzed by the discussed methods in most cases should be digested. Numerous methods can be applied, however, microwave wet digestion in closed systems is usually preferred. GM has been collected in order to measure zinc and copper ion content. Tissue samples from each animal have been put in Eppendorf tubes, and stored frozen and kept at –80°C till analysis. The samples were digested in the microwave digestion system Anton Paar Multiwave 3000 (as it was described earlier).

Zinc concentration was determined by means of F-AAS, copper was measured by means of electrothermal technique (ET-AAS) – the Perkin Elmer graphite furnace HGA 600 was used. The furnace program was optimized with the use of “Method development” program. Optimal conditions were as follows: atomization: time 5 s, temperature 2350°C; pretreatment time 30 s, temperature 1050°C; pyro/platform graphite tubes were applied. Cu determination was made at 324.8 nm, slit 0.7 nm, HCL lamp. Detection limit of Cu determination in ET-AAS was 0.5 mg/L. The obtained results of Zn and Cu determinations in the rat GM samples are presented in Table 4.

Estimation of the precision and accuracy of the applied methods

To determine accuracy and precision of the methods, analysis of the certified reference material was performed. The material chosen was bovine

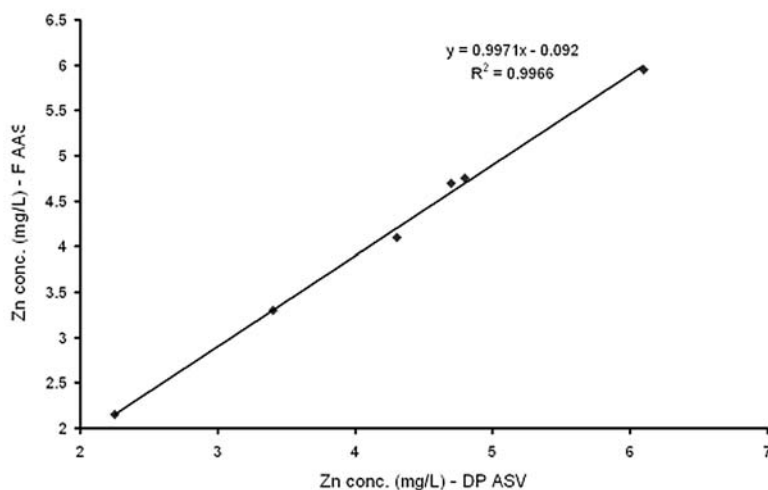

Figure 3 Correlation between the results of Zn concentrations in the rat gastric juice samples measured by means of DP ASV and FF-AAS methods

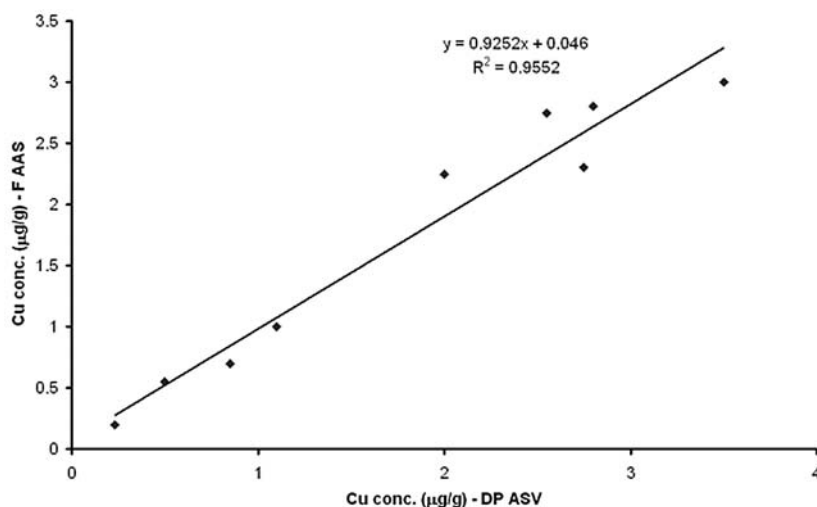

Figure 4. Correlation between the results of Cu concentrations in the rat gastric mucosa samples measured by means of DP ASV and FF-AAS methods

liver CRM No. 185 (EU Community Bureau of Reference). The certified value of Zn concentration was 142 ± 3 mg/g and that of Cu was 189 ± 4 mg/g. The values obtained for the digested samples (procedure described earlier in the text) and by means of both compared methods are presented in the Table 1 (for 5 repetitions of analysis).

Both methods are accurate, however, analysis of zinc and copper with the use of AAS are less precise comparing to the ASV method. Low precision of Cu analysis results from the fact, that determinations were performed in the manual mode (the sam-

ples were pipetted into the graphite tube manually). Also, lower precision of Zn versus Cu determination for both methods is a result of the possible contamination of the samples with the analyte, as zinc is an element abundant in the laboratory environment.

Statistical analysis of the obtained data

From the results presented in Table 2 and 4 and in Figures 3 and 4 it is clear that high level of agreement was achieved. It should be noted that precision of measurements is higher for DP ASV determinations – usually this value is less than 2% (RSD). In

the case of flame analysis (F-AAS) of not treated samples of rat GJ precision was in the range 4–7% (due to inhomogeneity of the samples). It may be concluded that both methods may be used for quantitative determination of Zn and Cu in GJ and GM samples. Obviously it implies, that other biological samples can be analyzed similarly as well. However, AAS method enables analysis of the total element concentration in the sample; with DP ASV one can measure only ionic forms of elements, thus the values measured depend on the sample pretreatment procedures.

CONCLUSIONS

The performed analysis proved comparable accuracy of measurements of both methods and higher precision of DP ASV. The DP ASV method enables speciation analysis what can not be made by AAS. Linear range of analysis is much higher for the DP ASV method than for AAS. Detection limit is also much better (of three orders of magnitude) in DP ASV than in AAS determinations.

The following facts were established:

- 1) DP ASV method and applied renewable silver amalgam film electrode can be readily used for quantitative determination of zinc and copper in gastric juice and gastric mucosa of rats;
- 2) the analytical procedure presented herein offers high precision and accuracy, what was confirmed by the analysis of the certified reference material and the use of an alternative method, i.e., AAS;
- 3) high precision, accuracy and low detection limits of DP ASV determination of Zn and Cu enable reliable measurements and observation of subtle changes of the analytes concentrations in complex biological samples;
- 4) in various instances the presented analytical system might be indispensable for quantitative analysis of ionic forms of elements (speciation analysis) at a very low, ppt level of concentration;
- 5) the use of the Hg(Ag)FE reduces substantially mercury consumption during measurements and analyst contact with this toxic element, comparing to the mercury drop electrode.

REFERENCES

1. Kadakia S.C., Wong R.K., Maydonovitch C.L., Nelson N.R., Henkin R.I.: *Dig. Dis. Sci.* 37, 513 (1992).
2. Mann N.S., Mann S.K., Brawn P.N., Weaver B.: *Digestion* 53, 108 (1992).
3. Parkin G.: *Chem. Rev.* 104, 699 (2004).
4. Barbarino, F., Toganel E., Brilinschi C.: *Clin. Pharmacol.* 14, 685 (1992).
5. Pihan G., Regillo C., Szabo S.: *Dig. Dis. Sci.* 32, 1395 (1987).
6. Wong, S.H., CH Cho, C. W. Ogle.: *Pharmacology* 33, 94 (1986).
7. Bulbena O., Escolar G., Navarro C., Bravo L., Pfeiffer C.J.: *Dig. Dis. Sci.* 38, 730 (1993).
8. Watanabe T., Arakawa T., Fukuda T., Higuchi K., Kobayashi K.: *Dig. Dis. Sci.* 40, 1340 (1995).
9. Escolar G., Navarro C., Sendros S., Bulbena O.: *Arch. Int. Pharmacodyn.* 290, 128 (1987).
10. Cho C.H., Luk C.T., Ogle C.W.: *Life Sci.* 49, PL189 (1991).
11. Brzozowski, T.: *J. Phys. Pharm.* 54 (Suppl. 3), 99 (2003).
12. Bravo, M.L., Escolar G., Navarro C., Fontarnau R., Bulbena O.: *Scanning Microsc.* 6, 855 (1992).
13. Yazdanpanah K., Moghimi N., Yousefinejad V., Ghaderi E, Darvishi N.: *Pak. J. Med. Sci.* 25, 404 (2009).
14. Sorenson J.R.: *Prog. Med. Chem.* 26, 437 (1989).
15. Sorenson J.R.: *J. Med. Chem.* 27, 1747 (1984).
16. Sorenson, J.R. In: *Inflammatory diseases and copper.* Sorenson JRJ Ed., p. 289, Humana Press, Clifton, NJ 1982.
17. Muobarak Jaber F., Tuorkey A., Abdul-Aziz K.K.: *Biomed. Pharmacother.* 63, 194 (2009).
18. Tuzen M.: *Trace Elements and Electrolytes* 19, 202 (2002)
19. Zheng Y., Shougui J.: *Guangpuxue Yu Guangpu Fenxi* 13, 71 (1993).
20. Bárány E., Bergdahl I. A., Bratteby L-E., et al.: *Sci. Total Environ.* 286, 129 (2002).
21. Lavi N., Alfassi Z.B.: *Analyst* 115, 817 (1990).
22. Bearn R.C., Close D.A., Malanify J.J., Umbarger C.J.: *Anal. Chem.* 46, 499 (1974).
23. Ali A.M.M., Farghaly O.A., Ghandour M.A.: *Anal. Chim. Acta* 412, 99 (2000).
24. Barthus R.C., Mazo L.H., Poppi R.J.: *J. Pharm. Biomed. Anal.* 38, 94 (2005).
25. Kruusma J., Banks C. E., Nei L., Compton R. G.: *Anal. Chim. Acta* 510, 85 (2004).
26. Mahajan R.K., Walia T.P., Sumanjit, Lobana T.S.: *Talanta* 67, 755 (2005).
27. De Vries W.T., van Dalen E.: *J. Electroanal. Chem.* 14, 315 (1967).
28. Wang J.: *Stripping Analysis: Instrumentation, and Applications* VCH Publishers, Deerfield Beach 1985.
29. Opoka W., Jakubowska M., Baś B., Sowa-Kućma M.: *Biol. Trace Elem. Res.* DOI 10.1007/s12011-010-8790-2 (2010).

30. Hoyer B., Florence T.M.: *Anal. Chem.* 59, 2839 (1987).
31. Tripathi R.M., Raghunath R., Mahapatra S., Sadasivan S.: *Sci. Total Environ.* 277, 161 (2001).
32. Moreno M.A., Marin C., Vinagre F., Ostapczuk P.: *Sci. Total Environ.* 229, 209 (1999).
33. Florence T.M.: *J. Electroanal. Chem.* 27, 273 (1970).
34. Wang J., Lu J., Hocevar S., Farias P., Ogorevc B.: *Anal. Chem.* 72, 3218 (2000).
35. Crew A., Cowell D.C., Hart J.P.: *Talanta* 75, 1221 (2008).
36. Lovric M., Komorsky-Lovric Š., Bond A.M.: *J. Electroanal. Chem.* 319, 1 (1991).
37. Baś B., Kowalski Z.: *Electroanalysis* 14, 1067 (2002).
38. Jakubowska M., Kubiak W.W.: *Anal. Chim. Acta* 512, 241 (2004).
39. Jakubowska M., Kubiak W.W.: *Electroanalysis* 17, 1687 (2005).
40. Jakubowska M.: *Electroanalysis* 22, 564 (2010).
41. Polish Patent No. P-319 984 (1997).
42. Baś B.: *Anal. Chim. Acta* 570, 195 (2006).
43. Jakubowska M., Baś B., Ciepela F., Kubiak W.W.: *Electroanalysis* 22, 1757 (2010).
44. Jakubowska M.: *J. Hazard. Mat.* 176, 540 (2010).
45. Kowalski, Z., Kołder E., Niewiara E.: *Euroanalysis V*, Kraków, Book of Abstracts I-46 (1984).
46. Kubiak W.W., Kowalski Z.: *Anal. Chem.* 61, 1598 (1989).
47. Niewiara E., Baś B., Kubiak W.W.: *Electroanalysis* 19, 2192 (2007).

Received: 14. 02. 2011