

Montana Tech Library

Digital Commons @ Montana Tech

Bachelors Theses and Reports, 1928 - 1970

Student Scholarship

Summer 6-1958

Metallurgical Applications of Polarized Light

Kenneth R. Evans

Follow this and additional works at: https://digitalcommons.mtech.edu/bach_theses



Part of the [Metallurgy Commons](#)

METALLURGICAL APPLICATIONS OF
POLARIZED LIGHT

A Thesis
Presented To
the Faculty of the Department of Metallurgy

29335

In Partial Fulfillment
of the Requirements of the Degree
Bachelor of Science in Metallurgical Engineering

by
Kenneth R. Evans

June 1958

TABLE OF CONTENTS

Introduction.....1
 Background.....1
 Purpose.....2
Theory of Polarized Light.....4
The Examination of Metal Surfaces.....12
Equipment and Procedure for Microscopy by
 Reflected Polarized Light.....15
Preparation of Specimens.....18
 Background.....18
 Actual Specimen Preparation.....20
Experimental Work.....21
Discussion and Conclusions.....24
Recommendations for Further Study.....31
Acknowledgements.....33
Bibliography.....34

TABLE

Summarization of Phase Examination Under the
 Polarization Microscope.....32

LIST OF FIGURES

Figure 1 - Symmetry of Ordinary Light.....	5
Figure 2 - Polarization of Light from Glass.....	6
Figure 3 - Production of Polarized Light.....	6
Figure 4 - Extinction of Polarized Light.....	6
Figure 5 - Polarized Light on a Calcite Crystal and in a Nicol Prism.....	8
Figure 6 - Reflection and Transmission of Light.....	9
Figure 7 - Diagram of a Fresnel Rhomb.....	11
Figure 8 - Polarized Light Incident on a Cubic Structure.....	14
Figure 9 - Metallurgical Polarization Microscope.....	16
Figure 10 - AISI 1010 Under Normal Illumination.....	22
Figure 11 - AISI 1010 Under Crossed Nicols.....	22
Figure 12 - AISI 302 Under Normal Illumination.....	25
Figure 13 - AISI 302 Under Crossed Nicols.....	25
Figure 14 - Stressed AISI 302 Under Normal Illumination.....	26
Figure 15 - Stressed AISI 302 Under Crossed Nicols.....	26
Figure 16 - Stressed AISI 302 Under Crossed Nicols, Stage Rotated 39°	27
Figure 17 - Stressed AISI 302 Under Crossed Nicols, Stage Rotated 69°	27
Figure 18 - Gray Cast Iron Under Normal Illumination..	30
Figure 19 - Gray Cast Iron Under Crossed Nicols.....	30

METALLURGICAL APPLICATIONS OF POLARIZED LIGHT

INTRODUCTION

Very little has been written concerning the theory of the metallurgical polarization microscope. Records of metallurgical studies utilizing this instrument are widely scattered among the literature, and are mostly material of an uncoordinated and irrelevant nature. It is the feeling of the author that a coordinated investigation of the metallurgical applications of polarized light will yield results providing the metallurgist with another means for the study of metals and their properties.

Background

Applications of polarized light in geology for the microscopic study of transparent mineral sections (chalcography) have aided tremendously in the identification of minerals. The determination of strain in transparent materials has even developed into a commercial process, used in testing finished glass articles.

Use of the polarization microscope in the study of opaque surfaces has been considerably less, partly due to the mechanical difficulties involved and the lack of knowledge of the theory for the polarizing microscope. Konigsberger¹, in

1909, first suggested the use of polarized light in the examination of opaque surfaces of metals, mostly ores. Wright^{3,4}, in 1919 and 1920, issued two papers on the subject. The first paper developed the mathematical theory from the electromagnetic theory of light; the second suggested improvements on the various methods in use. Dr. V. Schwartz⁵, in 1928, first promoted the use of the polarization microscope for metals. Despite the promotion of these early investigators there has not been a continued effort to extend these studies. A review of metallurgical literature leaves much to be desired concerning the phenomena of polarized light in metallurgy.

Purpose

It is felt that a series of systematic studies concerning the metallurgical applications of polarized light would benefit the field of metallurgy whether the results be positive or negative. The theory of polarized light would suggest assistance for the metallurgist in revealing grain structure, detection of preferred orientation, examination of oxide coatings, detection of internal strains and plastic deformation, and identification of phases in multiphase structures. Investigation of the above applications of polarized light has barely been undertaken. While it is realized that not all alloy systems will react to polarized light, efforts should be taken to provide information of various alloy

systems reaction to the phenomena.

There is a definite need in the metallurgical laboratories of instruction in our colleges to provide for the beginning student a means of illustrating to him the various subject matter being taught. In all too many instances the student cannot clearly see what is being taught him--the use of the polarization metallurgical microscope may overcome this in many situations. Industry, too, cannot afford to be without a method that would provide a means of quick examination of metal parts, perhaps a more accurate examination than is now employed. Moreover, a scientific principal is being neglected, and the intellectual knowledge and curiosity of the metallurgist should seek to determine that phenomena which will enable him to do his job in a more scientific manner.

It is with these purposes in mind that the investigation of the phenomena is being undertaken. It is an impossibility to investigate the subject completely in this short dissertation; therefore, a narrow segment of the field has been chosen for study in the anticipation of investigating a possible metallurgical technique and, moreover, to create interest in the principle involved that others will endeavor to approach it in a systematic manner.

The author has selected for study the phases of the iron-carbon phase diagram--that part of the diagram most familiar to the metallurgist. It is planned to examine the predominant Fe-C phases--ferrite, cementite, martensite,

graphite, and austenite--under the polarization microscope to determine optical characteristics that may provide a technique for identification of these phases in a multi-phase system. Some of these phases may be determined readily under normal illumination; however, the theory of polarized light would provide for a more positive qualitative identification, and would provide a rough quantitative estimate of the phases present. Retained austenite in hardened steels may be estimated if present in large quantities, but in amounts below 15% an extensive x-ray examination must be made for a quantitative value.⁶ The importance of a method for austenite determination cannot be over-emphasized.

A discussion of the theory of polarized light will enable the reader to review the phenomena of polarized light, and consider its importance to the metallurgist.

THEORY OF POLARIZED LIGHT

The nature of light may not be completely described as a wave motion, but many of its properties are best understood in terms of such a picture, and will be considered as such in this discussion. The interference of light is readily explained if the analogy of a mechanical wave is used with its 'up' or 'positive', and 'down' or 'negative' displacements. The particles transmitting light may, therefore, travel in a wave motion at right angles to the direction of propagation of the light. When a wave is propagated in an elastic medium each element of the medium is displaced. This displacement

at any point of the wave follows a regular sequence that is repeated at definite intervals of time called the period. The point reached on the wave at any instant is called the phase. If the disturbances from the displacements are in phase so as to produce a maximum displacement at the same instant, the resultant amplitude is the sum of each; likewise, if the maximum positive amplitude of one wave occurs at the same instant that the other wave has a maximum negative amplitude, the resultant amplitude will be the difference of the two. It can then be seen that the combination of two or more waves may result in re-enforced effects or in possibly no effect at all, depending upon the phase difference. This phenomena is termed interference. (8-1)

In ordinary light the plane of vibration about the axis of propagation is random, appearing symmetrical at a cross-section of the light ray (Fig. 1). A transverse vib-

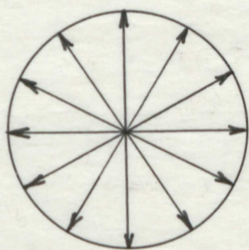

Figure 1

ration such as a ripple on a pond does not show this symmetry about the axis of propagation, but shows distinctive properties associated with a direction perpendicular to the propagation. The optical phenomena of polarization can only be understood in terms of transverse waves.

It is found by experiment that when natural light is reflected from the surface of a transparent substance it is partly polarized, the reflections being parallel to the reflecting surface. The amount of polarization that occurs depends upon the angle of the incident beam of light. The

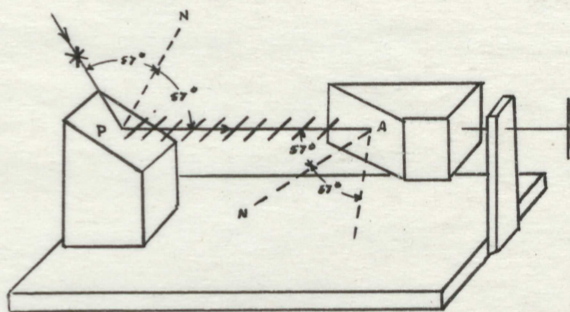

Figure 2

angle at which maximum polarization occurs is called the polarization angle. The value for glass, as shown in Fig. 2, is 57° .⁽⁷⁻⁷³⁹⁾ Even at this angle the amount of polarized light produced is relatively small. The same phenomena may

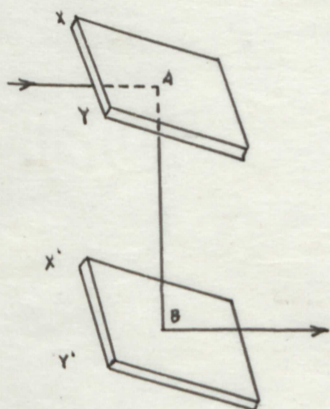

Figure 3

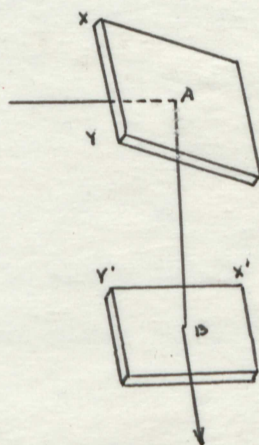

Figure 4

be illustrated in Fig. 3, where the incident beam is plane-polarized from A to B. In Fig. 4 the plane $y'x'$ is rotated 90° , and a marked decrease in intensity is noted from the

twice reflected light. In Fig. 3 the maximum reflection is noted when the glass plane is set at 57° , and in Fig. 4 extinction of the light occurs when the first glass plane is set at 57° ; the light that was reflected at A is such that none is reflected at B. (8-4)

The second mirror was rotated about the axis AB, and the light clearly possesses some characteristic relative to this axis of propagation which depends upon the angle of incidence. Such a result can only be explained for transverse waves, not for longitudinal or compressional waves. The plane of transverse vibrations may be specified with reference to that plane containing the incident ray, the normal ray and the reflected ray. It is conceivable that the vibrations in the plane of incidence should not be reflected in the same manner as the vibrations normal to the plane of incidence. Light in which these vibrations are all in one plane is called plane polarized light. The plane including the direction and motion of the light ray will be called the plane of polarization mentioned previously.

A common example of plane polarized light is given with the use of a rope. Transverse wave vibrations may be set up in all directions with the rope stretched horizontally. When the rope is unobstructed the waves travel the entire length of the rope, but with the rope passing through a verticle slit the horizontal component of the wave motion is cut out and only verticle vibrations may pass unobstructed.

A second slit will produce no change if kept vertical, but if placed in a horizontal position the vertical component will be cut out, and as a result all vibrations will be quenched. When the first slit is used only plane polarized vibrations will be passed, and it is called the polarizer. The second slit analyzes the plane polarized vibrations and is termed the analyzer. (7-738)

If the mechanical and electrical properties of a crystal are different in three mutually perpendicular axes, the crystal is said to be anisotropic. Similarly, the behavior of a transmitted electric vibration may be expected to depend upon the direction of vibration in an anisotropic medium. The phenomena observed are termed 'double refraction', with which the reader is familiar in terms of a calcite crystal.

Polarization occurs in a calcite crystal as illustrated in Fig. 5. The vibrations of the incident beam are resolved



Figure 5

into two directions, one parallel to the page and the other perpendicular to the page. Thus, the emergent rays E and O are at right angles to one another.

In a Nicol prism one of the two rays is eliminated

by internal reflection within the crystal. The prism is cut in two by a plane which is perpendicular to the principle plane of one face. With a thin transparent film of Canadian balsam the two polished surfaces are cemented together in their original position. This substance has refraction properties of a kind which so bend the rays coming to it through the face of the crystal that one of the rays is totally reflected within the crystal; whereas, the other ray emerges as plane polarized light. The Nicol prism may be used for producing polarized light, and in such an instance it is termed the polarizer; or it may be used for the detection and extinction of plane polarized light, in which case it is called the analyzer.⁴

At the glass surface it must be remembered that only part of the light is reflected; some of it is transmitted as shown in Fig. 6. (7-740) Brewster discovered that when light is incident at the polarizing angle p upon a medium of

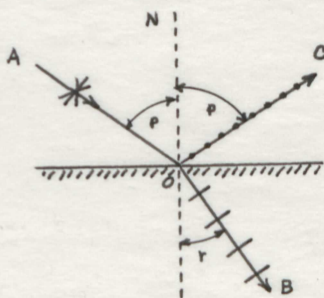

Figure 6

refractive index u , these terms are related by the following relationship,

$$u = \tan p$$

From this expression and from the law of refraction, it follows that,

$$\frac{\sin p}{\cos p} = u = \frac{\sin p}{\sin r}$$

therefore,

$$\sin r = \cos p, \text{ or } r \neq p = 90^\circ$$

The angle COB is 90° , showing that the reflected and refracted rays are at right angles for maximum polarization.

We may measure the refractive index of opaque surfaces such as metals by the methods illustrated above; we may also produce plane polarized light, but the methods do not state whether the reflected vibrations are in the plane of incidence or perpendicular to this plane. The vibrations are electric vibrations, and therefore, susceptible to magnetic displacement. They are mutually perpendicular and perpendicular to the direction of propagation. Hence, the optical phenomena described is determined by the electrical displacement. If the electric vector is parallel to the edge XY in Figures 3 and 4, the light is reflected at A; if the vibrations are all perpendicular to this edge, they will be transmitted. (8-6) Light polarized in the plane of incidence is such that the electric vector is perpendicular to the plane of incidence.

In a study of Lissajous' figures (6-600) it was shown that two harmonic vibrations of equal frequency, perpendicular to one another, produce an elliptical motion when

they are combined. The resulting ellipse will have various shapes depending upon the phase and frequency relationships between the vibrations. It was shown that if these components are equal and differ from one another in phase by one-quarter wave-length they will produce a circular motion. Circular polarized light may be studied using a Fresnel rhomb. Light incident to a glass-air interface at about 54° (Fig. 7), will

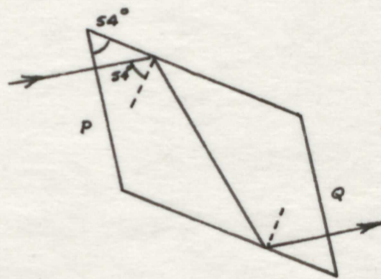

Figure 7

have a phase difference of 45° after reflection at the interface; after the second reflection the phase difference will be 90° . As we have seen the light will then be circularly polarized. If circularly polarized light were delivered to the rhomb, plane-polarized light would be emitted. Other methods are used to study circularly polarized light, but the advantage of the Fresnel rhomb is that the effectiveness of the 54° rhomboidal does not vary appreciably with wavelength, so the same rhomboidal may be used anywhere in the visible spectrum. (8-8)

Polarization effects are very striking from crystalline anisotropic materials; it is a common misapprehension that whenever such effects are observed they come from an

anisotropic substance. This is not necessarily true. A plane polarized beam of light strikes a substance, isotropic or anisotropic, and may be reflected in a simple or a complicated manner. The reflected beam may suffer rotation, introduction of ellipticity, or a change of intensity. Which phenomena should be taken advantage of depends upon a number of factors, some of which will be discussed as we proceed.

THE EXAMINATION OF METAL SURFACES

For optical purposes metals may be divided into two classes--optically isotropic, where the optical properties are the same in all directions, and optically anisotropic, where the optical properties vary with crystallographic direction of the crystalline specimen.

Plane polarized light incident upon the surface of an anisotropic substance can be resolved into a component parallel to a specific crystallographic direction, and a component perpendicular to this direction. The phase and intensities of these components may vary, as has been previously discussed. The variation results in elliptically polarized light. The resulting effect is a component of the light perpendicular to the incident plane polarized light that may pass through the analyzer placed 90° to the polarizer. The intensity of the transmitted light depends upon the angle between the crystallographic direction and the plane of polarization of the incident light. Four minima

of brightness parted by four maxima are obtained when the specimen is rotated on an axis normal to the surface. (8-62) In this manner anisotropic phases may be distinguished from isotropic phases by rotation of the specimen. The extent of ellipticity giving this result is sometimes small producing small variations in intensity. Two methods are used to make this effect more predominant:

1. A sensitive tint plate is placed between the polarizer and analyzer. This arrangement provides a very sensitive means of detecting double refraction or 'birefringence'.
2. A suitable diaphragm, to reduce effects caused by oblique incidence, is placed in front of the iris diaphragm in the illuminating train.

Isotropic materials (cubic structures as far as we will be concerned) reflect normal incident light unchanged. Thus the metal surface will not exhibit a characteristic reflection, and can be completely extinguished by the analyzer. There are two ways in which these isotropic materials may be made to react to the polarized light.

If the incident beam of light is not normal to the optically isotropic surface, elliptical polarized light will be produced. Therefore, it will not be possible to obtain complete extinction with the polarizer and analyzer crossed. In this manner effects similar to those obtained for anisotropic substances may be obtained. Two methods are

employed to produce this effect--deep etching and deposition of a surface film on the specimen. (8-74)

The optically isotropic cubic surface AC, in Fig. 8, has been etched by a solution which exposes only the (100) faces. Angle ABC must, therefore, be 90° . The incident ray

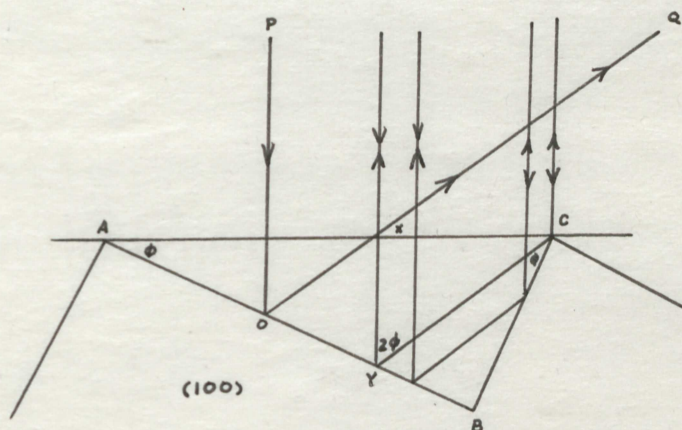

Figure 8

P, normal to the former surface AC, will be reflected at O and lost because it does not strike the surface BC.⁹ Similar incident rays reflecting between Y and B will reflect from surface BL. As angle ABC is 90° , the twice reflected rays will be returned in their original directions.⁹ The oblique reflections are elliptically polarized, and complete extinction will not occur. The intensity of the light passing through the analyzer will be a function of grain orientation, and will extinguish only when plane (100) lies on the surface.

Formation of a surface film on many isotropic metals has aided in the identification of metallic phases. The treatment has been quite extensive in the aluminum industry and is termed 'anodizing'. The method consists of polishing

the specimen followed by the forming of a suitable film on the surface; in the case of aluminum an aluminum oxide film is deposited. It has been suggested that the anisotropy transferred to the isotropic surface is not a result of the anisotropic surface coating, but due to the topography of the anodized surface which bears a relationship to the crystallographic structure. Further evidence to this idea was given when silver was evaporated upon an optically isotropic surface. The silver takes up the surface contour, and any grooves present before silvering are present afterward. The fact that polarization effects were present after coating with optically isotropic silver indicates that the polarization effects are due to a fine grooved-like structure rather than the anisotropy. (8-75)

EQUIPMENT AND PROCEDURE FOR MICROSCOPY BY REFLECTED POLARIZED LIGHT

For this thesis a Bausch and Lomb upright metallurgical microscope was converted to a polarization microscope. The microscope was adapted for polarized light by the addition of a polarizer in front of the reflector tube, and an analyzer inserted over the eyepiece. A rotating stage is essential in polarization work; so the ordinary upright stand on the microscope was removed, with a rotating stage replacing it. The rotating stage was not designed for use on the microscopic stand employed. Modifications were made for its adaptation, and it was finally put in place rather

crudely. The stage was not perfectly perpendicular to the axis of the light beam, and rotated the specimen in a circular path rather than in one spot. The later effect was not a serious disadvantage in the work; the former effect resulted in poor photo-micrographic representation of the specimens. An arrangement of polarizing equipment for the upright microscope is shown in Fig. 9.

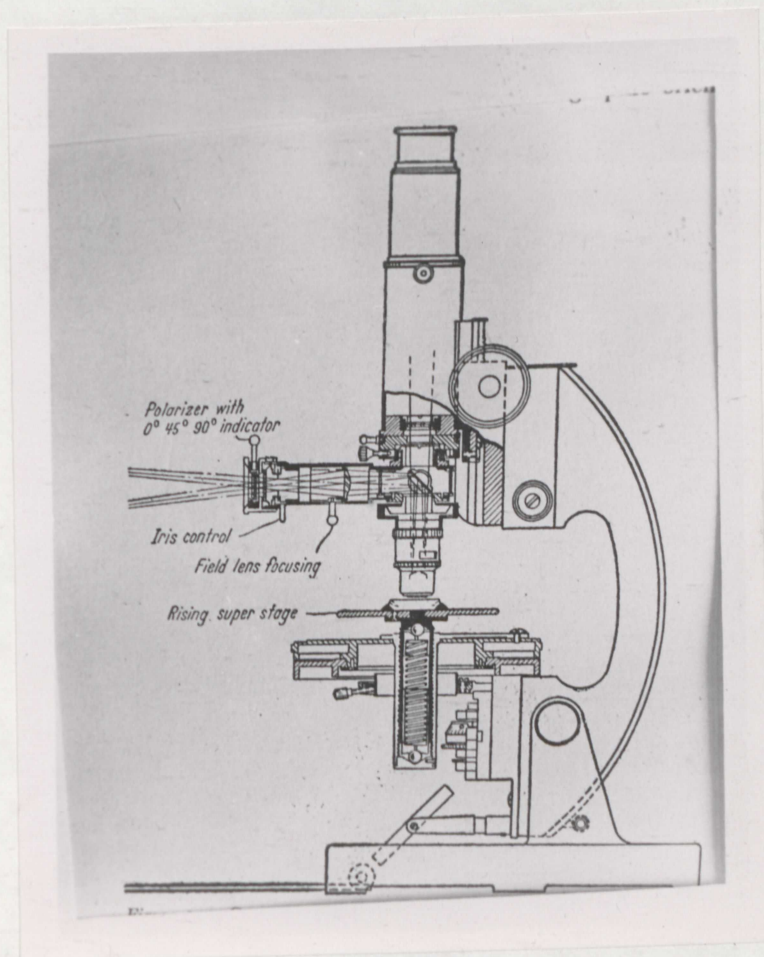

Figure 9

The usual examination of metallic surfaces may be carried out with the polarizer and analyzer removed; however, the polarizer is left in place as the difference in appearance between ordinary illumination and plane polarized

light is relatively small. No change in appearance will occur for isotropic constituents as the stage is rotated. Anisotropic constituents vary in brightness as the stage is rotated, passing through a maximum or minimum as the vibration direction of the incident light coincides with one of the extinction directions of the section. This type of examination is not as commonly employed as the one with crossed nicols, and was not employed in this thesis.

In the crossed nicols method, the analyzer and polarizer may both be rotated, along with the stage. An important first step is to insure a field of constant intensity. An isotropic section in the field will show extinction when the analyzer is at 0° with no variation in intensity as the stage is rotated. If a variation of intensity occurs in parts of the field, a diaphragm of the Berek type may be employed to limit the field to that part maintaining constant intensity.

The examination should begin with the nicols at extinction, for a characteristic color or tint will be given by the grains of a certain constituent and easily identified. When the nicols are slightly uncrossed, a variation of colors will be given and the constituents may become confused. The colors given have no relationship to the faint tints usually given by plane polarized light without the analyzer. An example of this is given by the mineral covellite, CuS , which has a strong blue-white reflection pleochroism, but appears

orange-yellow under crossed nicols. (8-64)

Anisotropy varies with wavelength for many substances, so extinction will occur at different rotation angles for various substances. The angles may be measured if the proper wavelength is employed. When using white light, the constituents change from one color to another upon extinction. This sequence of changes may be observed as characteristic of a particular constituent, and used as a means of identification.

Procedure for the examination of constituents in this thesis employed the crossed nicols method. The polarizer, analyzer, and stage were rotated in various combinations, and the optical properties noted.

PREPARATION OF SPECIMENS

Background

Microscopic examination of specimens under polarized light usually requires careful preparation of sections. Erroneous results can be reported unless precautions are taken in specimen preparation. Light is scattered and depolarized from polishing imperfections such as the remnants of emery scratches, pits, relief effects due to multiphased alloys, and cleavages formed during the preparation of specimens. (8-120) Anamalous results may be attributed to faulty polishing, and the effects of anisotropy may be

partially hidden or completely covered due to the effects of surface flow, and/or oxidation during preparation. It is even possible to recrystallize some alloys of low melting point during polishing, creating a false structure.

A polished scratch-free surface must be obtained to examine a section under polarized light. Any scratches remaining after polishing are over emphasized under the crossed nicols. It is preferable for all phases of the structure to lie perfectly flat; otherwise, polishing material may become entrapped at the edges of those phases standing above the others. In a multiphase structure the different mechanical properties of each phase lead to varying amounts of cold working of each phase during polishing, resulting in a non-uniform specimen surface.

Due to the difficulties in obtaining good, reliable specimen surfaces by mechanical polishing it may be necessary to develop a suitable treatment of electro-polishing that will completely eliminate scratches, reduce surface flow, and reduce false structures. Perryman and Lack⁽⁸⁻⁷¹⁾ have reported that electrolytically polished surfaces give better grain contrast under polarized light than mechanically polished specimens. This effect may be due to the removal of scratches by the electrolytic polish, or due to the anodic film formed during polishing.

Dayton² pointed out that electrolytic polishing would not be applicable to alloys with multiphase structures; the non-uniform attack resulting from the different electro-

chemical properties of the various alloy phases would result in a non-uniform polished surface.

Monogh⁽⁸⁻⁷¹⁾ has indicated the need for examining the polished specimen in the unetched condition, because of the danger of confusing true anisotropy and anisotropy due to the etching solution. It has previously been pointed out the necessity of deep-etching some cubic structures for an examination under polarized light.

Actual Specimen Preparation

All samples were mounted in a Buehler mounting press, and put through a series of grinding papers to the 000 paper. After careful grinding the specimens were mechanically polished on a lap wheel with an alumina abrasive.

The mechanical polishing procedure created problems of specimen surface condition as too many scratches were present. It was decided to try an electrolytic polishing procedure on low to medium carbon steels. Following much experimental work on developing an electrolytic polishing technique, an interfering anodic film remained. The idea of electrolytic polishing was abandoned for the lack of time to experiment with the current densities needed for various alloy compositions.

All of the steel specimens were etched in a 4% nital solution, except for AISI 302 which was etched in H₂O₂: HCl at a 4 to 1 ratio. The nital etch was expected

to aid in the identification of cubic structure present in the steel by the methods discussed; likewise, it was hoped the peroxide etch would aid phase identification of austenitic stainless steels.

Experimental Work

A sample of AISI 1010 steel was tempered at 1000°F for 15 minutes to obtain a ferrite microstructure (Fig. 10). The polished sample was etched in 4% nital for six seconds and observed under the polarization microscope (Fig. 11). When the nicols are crossed the ferrite grains are mostly extinguished and reflect a lavender-blue color, while the grain boundaries illuminate as a bright gold color. Inclusions present in the structure are strongly reflected as seen in Fig. 11.

Extinction of this nature occurs twice in 360°--180° apart. No noticeable change occurred upon rotation of the analyzer with the polarizer removed. Rotation of the stage with the nicols crossed produced four extinction angles in 360°--90° apart. These angles are noticed to be a function of grain orientation; therefore, they cannot be measured as constant for any one phase. The grain boundary material and inclusions are assumed to be iron carbide. It was observed that upon rotation of the polarizer 'n' degrees from the previous extinction setting, the analyzer could be rotated 'n' degrees for a new extinction position. The etching time of the sample was extended at intervals of three seconds

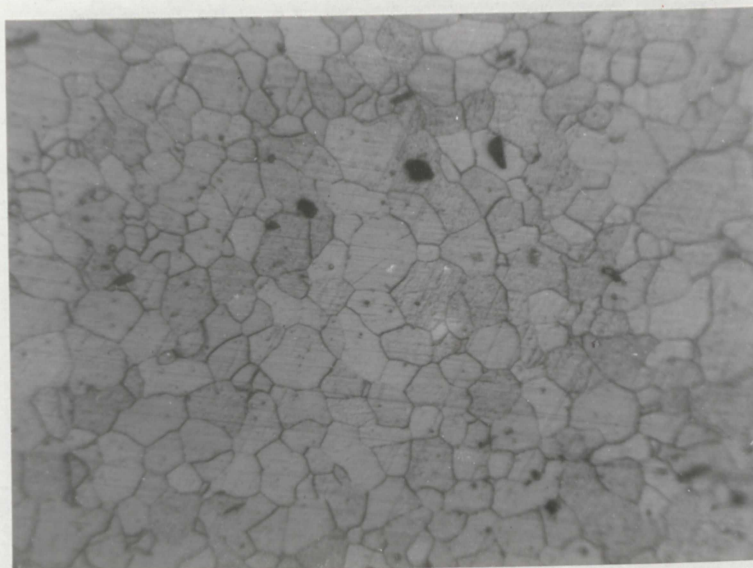

Figure 10
AISI 1010 tempered at 1000°F for 15
minutes, etched in 4% nital. Normal
illumination at 450 X.

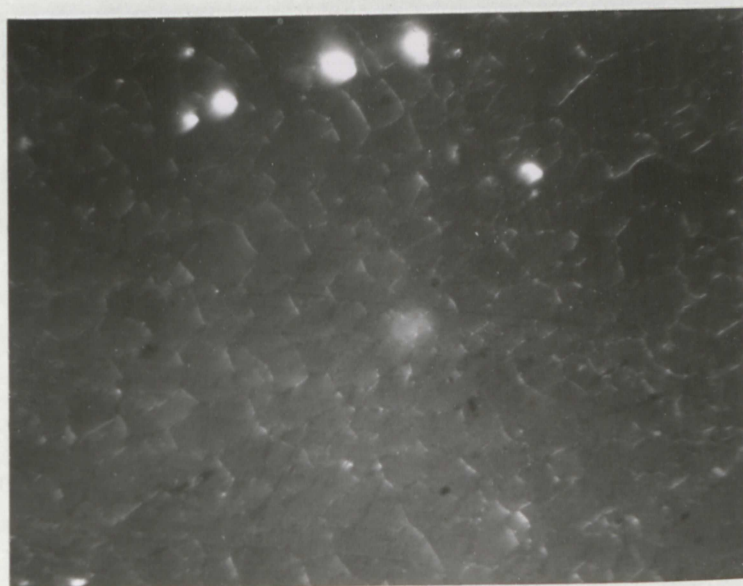

Figure 11
Same as Figure 10 except viewed under
crossed nicols.

to 39 seconds. No additional polarization effect was noticed; the microstructure became distorted as a result of the over-etching.

A sample of AISI 1048 steel was austenitized at 1700°F for one-half hour and quenched in water to obtain a microstructure of martensite. The polished specimen was etched in 4% nital, and observed under the polarization microscope. Under the crossed nicols a slight darkening of the surface developed, but no extinction angles were observed for the martensite. Later in the work samples of AISI 1015, AISI 1048, AISI 1066, and AISI 1093 were austenitized at 1850°F for 1 1/2 hours, and quenched in water. Martensite was observed in all of the specimens under ordinary illumination. The quantity of martensite present was low in some of the specimens due to the effect of sample size on the quenching rate. The AISI 1015, and AISI 1048 showed what was thought to be martensite reflections after being etched in nital. The reflection approached that of Fe₃C in color, appearing not as bright due to the duller background present in the microstructure. Extinction, likewise, occurred four times in 360°. Support of this type of reflection for martensite will be given in a discussion of austenite observations given below.

The AISI 1066 and AISI 1093 specimens were tempered at 250°F for one half hour. Upon being polished and etched they gave a slight reflection as was attributed to martensite

in the above discussion.

Samples of AISI 302 stainless steel were austenitized at 2000°F for 1 1/2 hours, and quenched in water to retain austenite (Fig. 12). A qualitative x-ray examination substantiated the belief that all of the austenite was retained. The polished and etched specimen reflected a bluish-lavendar color under the crossed nicols, with the differences in grain orientation being clearly distinguishable (Fig. 13). The tint of bluish-lavendar that each grain reflected varied with grain orientation. Each grain extinguished 4 times over 360° rotation of the stage.

A specimen of the same AISI 302 used above was stressed by bending. A polished and etched section of it appears in Fig. 14. According to theory⁽¹⁰⁻²⁷⁰⁾ the face-centered cubic austenite was stressed to form tetragonal martensite. Observation under the crossed nicols (Fig. 15) reveals the same type reflection obtained for martensite in AISI 1015 and AISI 1048. Extinction also occurs 4 times by rotating the stage 360°. Figure 16 illustrates an extinction angle for a grain of the stressed AISI 302, 39° from the zero position. At 69° the martensite in the grain has regained its reflectiveness, while other properly oriented grains extinguish at this angle (Fig. 17).

Discussion and Conclusions

From the experimental work carried out it has been shown that characteristic reflections exist for the

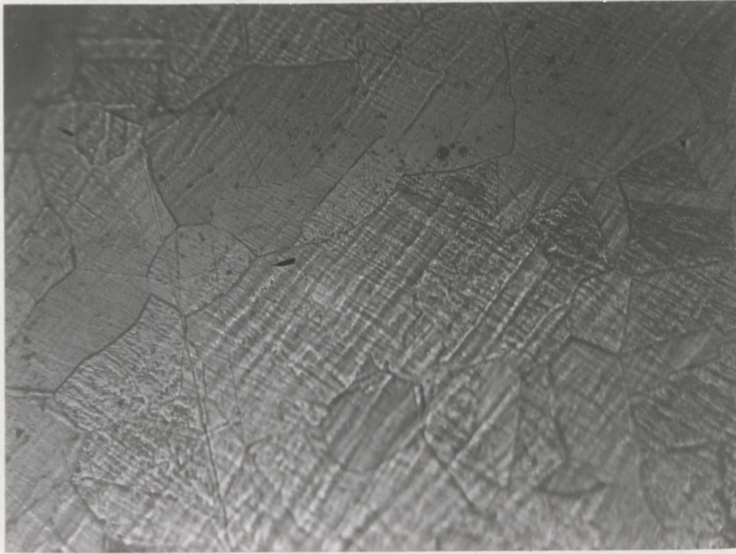

Figure 12
AISI 302 austenitized at 2000°F for
1 1/2 hours and quenched in water.
Etched in 4 H₂O₂: HCl. Normal
illumination at 250 X.

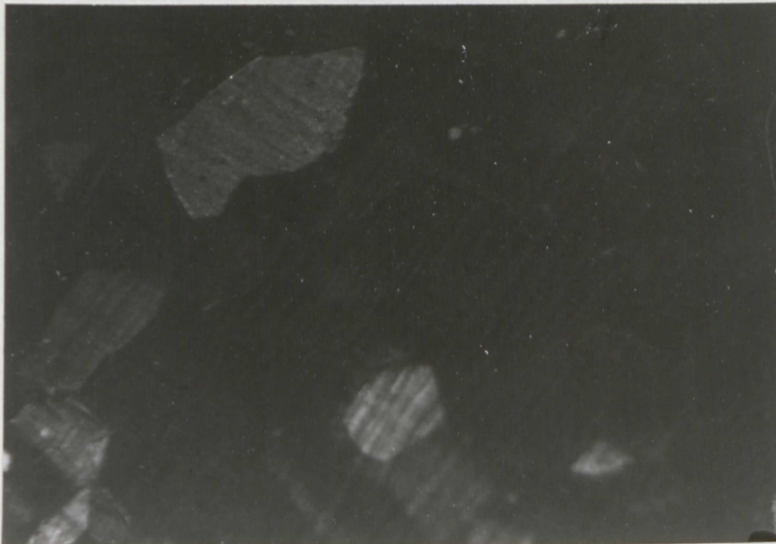

Figure 13
Same as Figure 12 except viewed under
crossed nicols at 250 X.

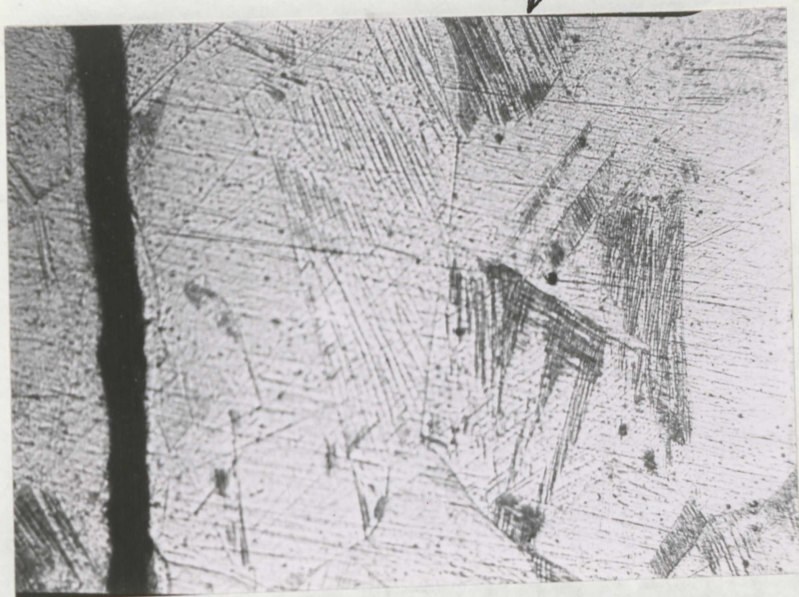

Figure 14
Same as Figure 12 except stressed
by bending.

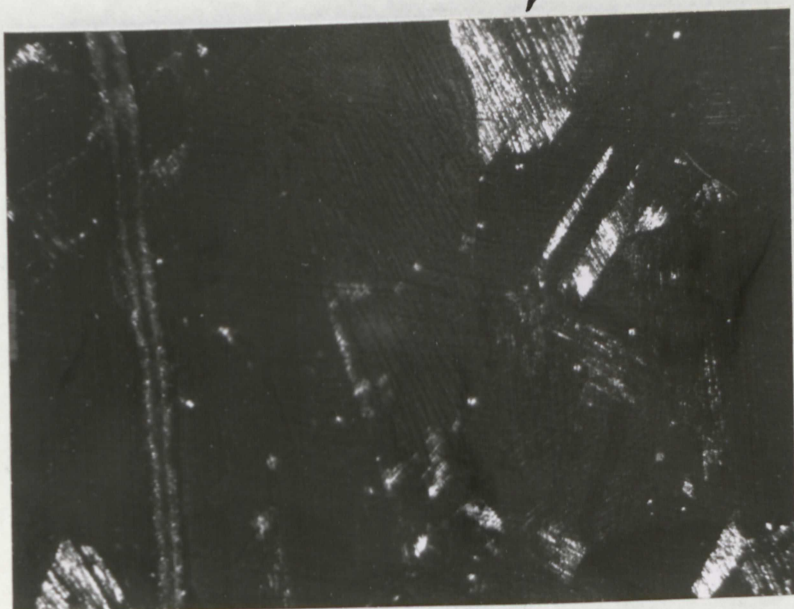

Figure 15
Same as Figure 14 except viewed under
crossed nicols at 250 X.



Figure 16
Same as Figure 15 with the stage
rotated 39° .

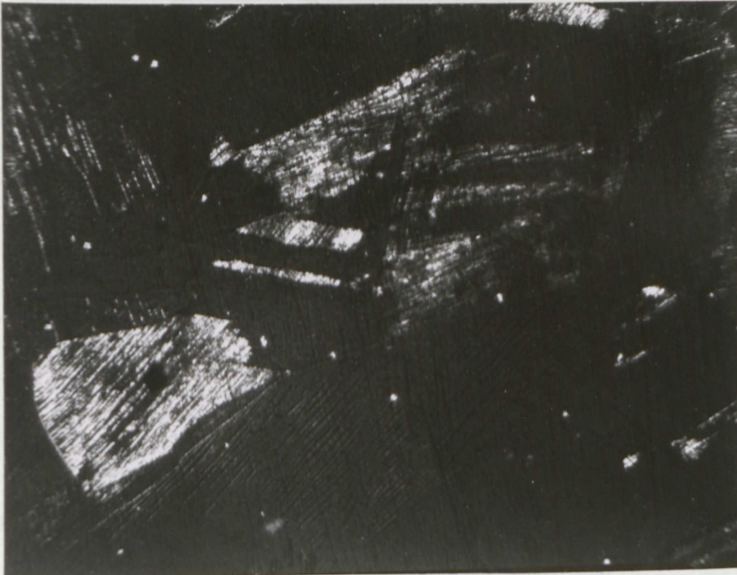

Figure 17
Same as Figure 15 except stage ro-
tated 69° .

phases of the iron-carbon system studied in this thesis.

An obstacle in phase identification exists due to the similar reflections given by the ferrite phase and the austenite phase. These phases are not found together too often. The similar reflections of Fe_3C and martensite will impose a problem in phase identification. A knowledge of the alloy composition should give the metallurgist an idea of phases that may be present.

The main obstacle in the study of steels under the polarization microscope is the fine grain sizes present in many steels. AISI 4840 and AISI 52100 were heat treated to give some retained austenite. Examination of the specimens under crossed nicols showed some yellow-gold reflection indicating possible Fe_3C , but the extinguished background was so fine-grained at 450 X that any two phases present could not be distinguished. Higher magnifications would have to be used to relieve the fine grain size obstacle; however, examinations indicate that the effectiveness of the polarization microscope decreases at too high of a magnification--greater than 1000 X.

This is not to say that the phenomena cannot be employed for the examination of steels; but that the observer should be familiar with the phenomena to interpret what is viewed intelligently.

The cast iron portion of the iron-carbon system may be readily examined under polarized light. Specimens

taken for study are as follows: gray cast iron, mottled cast iron, partly malleable cast iron, fully malleable cast iron, type GA meehanite, and type GC meehanite. The pearlite in these cast irons extinguished twice as the analyzer was rotated 360° . Ferrite and cementite reacted in the manner previously described for low-carbon alloys. Graphite did not produce a characteristic reflection.

The examination of these cast irons produced evidence that an effective examination of cast irons can be done under polarized light. Figure 18 shows a gray cast iron under normal illumination. The pearlite and graphite are readily distinguishable. Under crossed nicols (Fig. 19) the pearlite islands are readily visible, and the characteristic lavender-blue color of ferrite is easily observed. The phases present in all of the cast irons studied were readily identified under polarized light--more readily under polarized light with the characteristic reflections known than under normal illumination. The examination of fine grained steels illustrated the minimum effectiveness of the polarization microscope, while the examination of cast irons exemplifies the utility of the technique.

The conclusion of this thesis must be that the phases of the iron-carbon diagram studied may be detected with the metallurgical polarization microscope. Maximum efficiency of the technique will be possible with an experienced observer of the phenomena--the predominant limitation being the grain size of the specimen. Additional



Figure 18
Gray cast iron etched in 4% nital at
450 X under normal illumination.

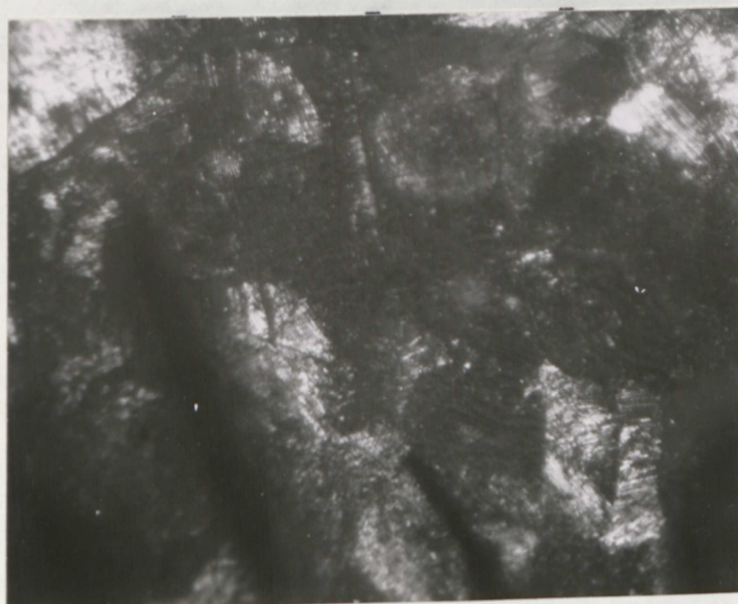

Figure 19
Same as Figure 18 except viewed under
crossed nicols.

studies should be made to verify and broaden the information obtained in the problem study.

RECOMMENDATIONS FOR FURTHER STUDY

The polarization microscope employed in this thesis was satisfactory, except for the rotating stage used. The analyzer from the microscope could be used on the metallograph, and an analyzer from polaroid sheet. The rotating stage on the metallograph could then be effectively used in the examination.

For future studies it is suggested that aluminum, copper, or tin alloy systems be studied. The effects of polarized light may be studied more closely from the coarser grained structures obtainable in the above systems. After the characteristics of polarized light on opaque metal surfaces are more fully known, a more complete study can be made on the fine grained steels used in this study.

It is hoped that this paper will provide a stimulating and informative background on the metallurgical possibilities of polarized light, that the work may be carried on with zeal.

SUMMARIZATION OF PHASE EXAMINATION

UNDER THE POLARIZATION MICROSCOPE

PHASE	COLOR OF REFLECTION EFFECT OF ANALYZER ROTATION ROTATION--360° AT EXTINCTION	EFFECT OF STAGE ANALYZER ROTATION ROTATION--360°
Ferrite	Blue-lavendar	No variation of grain orientation
Cementite	Yellow-gold	Four extinction angles
Martensite	Yellow-gold	Four extinction angles
Austenite	Blue-lavendar	Variations in grain orientation shown
Graphite	No reflection	No effect

ACKNOWLEDGEMENTS

I would like to thank Professor R. I. Smith and Dr. C. W. Haynes for their assistance in answering my questions throughout this study. Professor Smith provided the initial idea for the study, and was at hand at all times with helpful suggestions.

The Montana Bureau of Mines receives my appreciation for the use of the rotating stage employed in the study. Mrs. L. B. Peck and the Library Staff are thanked for their helpfulness in obtaining library research material.

BIBLIOGRAPHY

1. Ahmad, N., "Micro-optical Investigations of Non-Ferrous Alloys By Polarized Light", Metallurgia, v. 9, Dec. 1933, pp. 33-37.
2. Dayton, R. W., "Theory and Use of the Metallurgical Microscope", Trans. Amer. Inst. Mining & Met. Engrs., v. 117, (1935) pp. 119-127.
3. Wright, "Polarized Light in the Study of Ores & Metals", Proc. Amer. Phil. Soc., 1919, v. 58, p. 401.
4. Wright, "Examination of Ores & Metals in Polarized Light", Trans. A.I.M.E., 1920, v. 63, p. 370.
5. von Schwartz, "Micro-Optical Investigation of Non-Ferrous Alloys By Polarized Light", Metallurgia, v. 4, 1931, p. 180.
6. Cullity, Elements of X-Ray Diffraction, Addison Wesley, Reading, Mass., 1956.
7. Hausmann and Slack, Physics, van Nostrand, New York, 1948.
8. Conn & Bradshaw, Polarized Light in Metallography, Academic Press, London, 1952.
9. Jones, "Reflection of Plane Polarized Light by Etched Metals", Philosophical Magazine, v. 48, July 1924, pp. 202-216.
10. Brick and Phillips, Structure and Properties of Alloys, McGraw-Hill, New York, 1949.