

DEVELOPMENT AND TESTING OF THE PROPULSION SYSTEM OF MARTA AUV

B. ALLOTTA*, R. COSTANZI*, J. GELLI*, L. PAOLUCCI*, L. PUGI* AND A. RIDOLFI*

*Department of Industrial Engineering (DIEF)
University of Florence
50139 Florence, Italy

Keywords — Propulsion Systems, Autonomous Underwater Vehicles, Marine Robotics, Marine Propulsion.

Abstract — This work deals with the design of the propulsion system of a modular AUV (Autonomous Underwater Vehicle). The authors describe the design methodologies and the testing devices used for the fast prototyping of MARTA (MARine Tool for Archaeology) AUV actuation system, including drivers, motors and propellers. In particular, the authors introduce the design criteria followed for the preliminary testing activities and the methodologies adopted for fast testing and prototyping of the proposed solutions. This is a quite important topic considering the high customization and the reliability required by this kind of applications.

1 INTRODUCTION

MARTA (MARine Tool for Archaeology) is a modular AUV designed and developed by the University of Florence in the framework of the ARROWS (ARchaeological ROBot systems for the World's Seas) European project. The vehicle is composed of several modules, each one dedicated to a particular task (e.g. propulsion, sensor payloads, power supply, etc.). This way, MARTA AUV can be customized according to the mission profile. Since there are interchangeable propulsion modules, different propulsion technologies have been investigated ranging from conventional oil-filled thrusters, a technology previously adopted by the authors for the Typhoon AUV developed during the THESAURUS project [1],[2],[3], to more advanced solutions, such as the rim drive thrusters or a ring waterjet systems. In this work, the authors focus their attention to the criteria adopted for the fast design, prototyping and testing of this kind of systems.

As visible in Figure. 1, the default propulsion layout of MARTA AUV is composed of six thrusters used to control all the degrees of freedom of the vehicle, except the roll one. This propulsion layout is quite similar to other existing torpedo-shaped vehicles, e.g. the Folaga AUV produced by Graaltech [4]. A brushless motor coupled with a fixed pitch propeller through an epicycloidal gearbox controls each thruster.

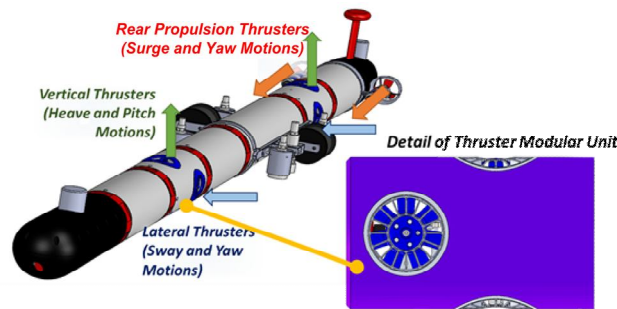

Figure 1: MARTA AUV, division in modules and propulsion system

In order to seal the motor, to compensate the external pressure and to protect the electrical and mechanical components from corrosion and excessive overheating, both motor and gearbox are filled with an inert liquid, typically a lubricant oil or a halogenated hydrocarbon with known stable properties. Unfortunately, the behaviour of oil-filled actuators is quite different compared to their nominal specifications referred to the motor in air: for this reason, the electrical and mechanical behaviour of both motor and thrusters have to be identified [5]. Finally, it should be considered that the modular design of MARTA vehicle implies a high variability of the hydrodynamic vehicle features: in particular in the lightest vehicle configuration a minimal length of about 3 m and an equivalent diameter of about 18 cm should be considered. On the other hand when all the payload modules are installed (e.g. the vision module, equipped with external cameras and LED lamps for stereo vision) the length of the vehicle rise to 4 m and the frontal area that has to be considered for the calculation of drag resistances increase to an equivalent diameter of about 30 cm. Such a variability of the vehicle sizes has been taken into account during the preliminary testing of the proposed propulsion systems.

The authors have thus developed some low cost testing devices, to identify the motor electrical behaviour with different loading conditions and its corresponding performances in water when coupled with gearbox propulsion system and propeller. The main advantages of these devices is represented by their easy maintenance thanks to 3D printing fast prototyping technologies and by the scalability of the proposed sensor layouts. The proposed testing system, described in section 2, has been successfully used for the testing of the current propulsion layout of MARTA AUV. The aim of these tests was indeed to determine the optimal shape and dimensions of MARTA AUV propellers.

2 TESTED THRUSTERS

As visible in Figure 1 MARTA AUV is actuated using six fixed pitch propellers (two main propellers on the vehicle tail, two lateral thrusters and two vertical ones). The two rear propulsion thrusters are intended to perform surge and yaw motions. They are not incorporated in the hull as the vertical and lateral thrusters are. For this reason, the propellers used for the rear thrusters are different from the lateral and vertical ones. Rear thrusters are equipped with Ka-4-70 propeller type ducted with a 19-A nozzle; tests on it will be described in section 2.2. The other four thrusters, due to the particular conditions they work, are equipped with a customized propellers type; tests on it will be described in section 2.3. In order to obtain a modular system, with simplified maintenance, each propeller exploits the same electric motor and actuation system: a brushless 100W Maxon motor with main data reported in Table I. Compared to previous projects [1],[2], a sensorless drive system is adopted since it drastically simplifies the motor wiring and consequently reduces the costs of watertight connectors. Considering the vehicle reconfigurability in terms of encumbrances and hydrodynamic resistances, the same motor can be equipped with different gearboxes having a reduction ratio from 1:3.8 to 1:14.

Table 1 Main features of the tested motor

Main features of the Tested Motor			
<i>Property</i>	<i>Value</i>	<i>Property</i>	<i>Value</i>
Model	386676	Nominal Voltage	18 [V]
No-load speed	31000 [rpm]	Nominal Current	9.11 [A]
Nominal Speed	28300 [rpm]	Nominal torque	49 [mNm]
Torque Constant	5.53 [mNm/A]	Speed Constant	1730 [rpm/V]
Speed/torque gradient	48.4 [rpm/mNm]	Planetary gearbox reduction ratio	1:3.8 (smallest vehicle) 1:14 (longest vehicle)

2.1 Bollard thrust test with torque measurements

The execution of bollard thrust test in a pool is one of the most common way to identify the first quadrant response of a propeller, calculating the values of the thrust $K_t(J)$ and torque coefficients $K_q(J)$ for a null value of the advance coefficient J .

The three dimensionless coefficients are defined respectively according to equations (1), (2) and (3):

$$K_t = \frac{T}{\rho n^2 d^4} \quad (1)$$

$$K_q = \frac{Q}{\rho n^2 d^4} \quad (2)$$

$$J = \frac{V_a}{nd} \quad (3)$$

where the following symbols are adopted:

- T , the thrust delivered by the propeller;
- Q , the torque needed to move the propeller;
- n and d rotation speed [Hz] and propeller diameter;
- ρ is the fluid density;
- V_a advance speed.

Once the Bollard thrust and torque coefficients are calculated, their values can be easily extrapolated from tabulated relationships known for certain kinds of profiles, such as the chosen ducted propeller. Alternatively, simple linear interpolating laws can be adopted, e.g. (4), that, as visible in the comparison of Figure 2, can be a quite good approximation of the propeller response in the first quadrant [9]:

$$K_t(J) = K_t(0) \left(1 - \frac{J}{k_{null}(p/d)} \right) \quad (4)$$

where the following symbols are adopted:

- p is the propeller pitch;
- k_{null} is an interpolation coefficient whose value is typically near to one.

As a consequence, the execution of this kind of tests is quite useful since both loading and thermal conditions are quite realistic and can be used to approximately identify the first quadrant behaviour of the tested propeller. However, an investigation of the four quadrant behaviour of the propeller could involve more expensive testing devices such as the one proposed by Pivano [10], able to reproduce the relative motion of the tested propeller corresponding to different values of the advance coefficient.

The cheap and simple testing device proposed in this work is described in figures 3, 4, 5 and 6: the tested thruster is constrained using an isostatic structure, composed of three joints, a cylindrical one (able to suppress 4 degrees of freedom) and two links (each one able to suppress 1 degree of freedom).

Neglecting the friction on all the other joints and referring to the scheme of Figure 3, the longitudinal thrust of the propeller is balanced only by the constraint of the longitudinal link $L1$, which is customized introducing a simple traction-compression load cell.

With the same principle the torque Q applied to the propeller should be measured by estimating the reaction torque on constraints. In particular the force that can be measured with a traction-compression cell on link $L2$ is directly proportional to the applied torque Q and inversely to the distance l between the axis of the link and the one of the cylindrical joint.

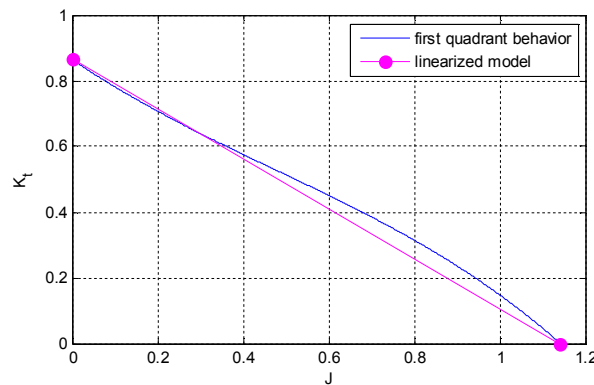

Figure 2: Comparison between measured K_t , values for Ka-4-70 propeller ducted with a 19-A Nozzle (propeller p/d ratio is equal to 1.2)

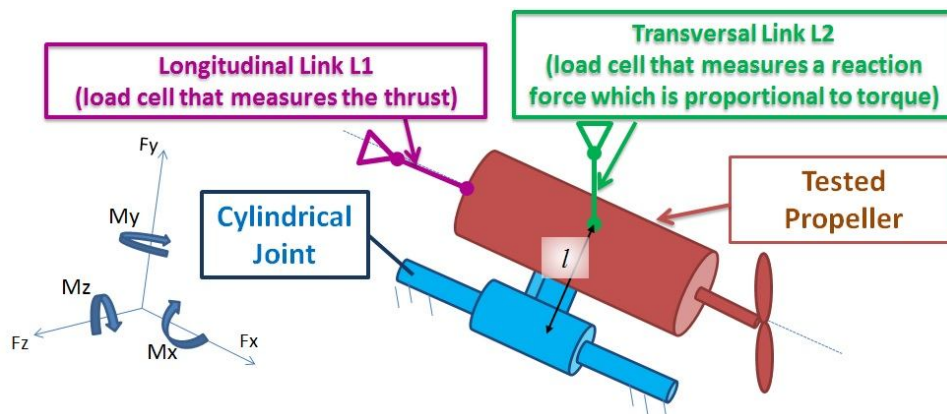

Figure 3: Scheme of the proposed testing device.

The main advantages of the proposed approach can be clearly understood looking at the schemes of Figure 3, Figure 4 and at the photo of the testing system (Figure 5):

- **Modularity and Easy Customization:** the system is modular and the measurement range can be easily customized by changing the range of the adopted traction-compression load cells or even by adjusting the distance l . As a consequence, it is quite easy to adapt and replicate the same measurement layout for the testing of different propulsion systems.

- Costs and Availability: the cost of a standard traction load cell is quite lower with respect to torque sensors and more general to corresponding multi axis sensors (especially water proof sensors).
- Design optimized for the using of fast prototyping techniques: as visible in Figure. 6, the design of the system is optimized to exploit as much as possible the usage of 3D printing.

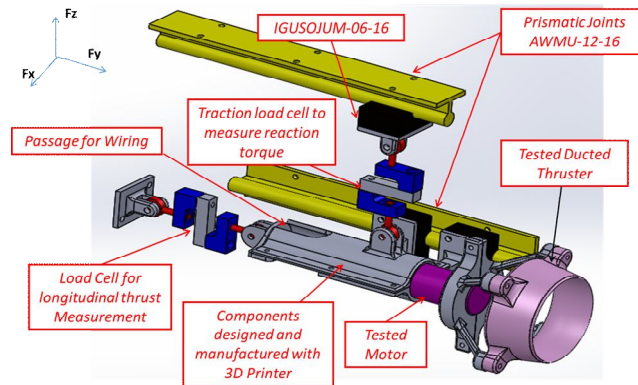

Figure 4: CAD of the proposed testing device.

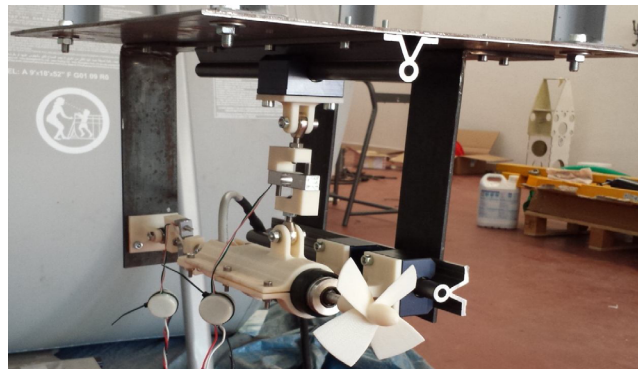

Figure 5: Bollard Thrust Test.

Low cost anodized aluminium load cells are used: since they are not designed for underwater applications, they are here protected using a plastic spray film. The mechanical interface of the cell with the link is customized as visible in Figure 6. In order to improve the measurement quality, signal-conditioning units (cell amplifiers) have to be placed near to the cells: miniaturized amplifiers are used (Figure 6). Another important piece of information is the motor and, consequently, the propeller rotational speed. This is not always accessible during the test since it depends from the availability of sensors on the motor (most commonly Hall Sensors or Encoders) or alternatively from the adopted motor drive. In the proposed testing layout, the rotational speed is estimated from electric measurements performed directly on motor drive wirings. In particular, it is directly estimated from the measurement of the first

harmonics of voltages applied to the phases of the tested brushless motor (which can be treated as a particular case of synchronous machine).

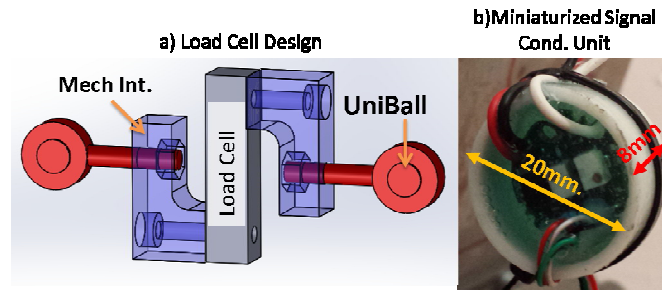

Figure 6: Customized load cell interface (a) and miniaturized signal conditioning unit (b).

Additional measurements performed on the tested motor and the corresponding sensors are described in Table II.

Table 2 Main features of the tested system.

<i>Measurement</i>	<i>Sensor/Method</i>
Mean Temperature of Motor Windings	Thermocouple in the stator windings
Power absorbed by the Motor Drive	Voltage and Current sensors on the DC source used to feed the motor

In order to evaluate the power absorbed by the drive system and the electric torque of the motor, this kind of estimation can be performed from the real time measurement of currents and voltages on motor wiring by use of estimators known in literature [11].

2.2 Experimental Results on Ka-4-70 propeller

There is a wide and complete literature about Ka-4-70 series propellers ducted with a 19-A nozzle. For this configuration it is easy to find the data concerning both first and four-quadrant operation [6],[7],[8]. In order to verify the performances of the chosen motor and the drive system, the Bollard thrust test has been performed in the pool of the MDM Lab (Mechatronics and Dynamic Modelling Laboratory in Pistoia, Italy) of the University of Florence. To establish the optimal shape and dimensions of MARTA AUV rear propellers it has been necessary to test different propellers of various dimensions and pitch over diameter (p/d) ratio. In Figure 7 and Figure 8 the delivered thrust is plotted as a function of the power absorbed by the motor and of the rotor speed according to different propeller diameters. For these measurements, it has been used a gearbox with a reduction ratio of 1:40, the p/d ratio of the propellers is 1.4. These measurements together with the characteristics of the motor made

possible to define optimal propellers dimensions. Obviously, the main criteria is to maximise the thrust delivered by the propeller while maintaining optimal working conditions of the motor and minimum power consumption. The Maxon motor described in Table 1 reaches its optimal working point at a speed around 28000 rpm. According to Figure 7 the best performance in terms of power consumption is obtained with a propeller of 85mm in diameter. Of course the use of propellers with lower diameter guarantees better working conditions as shown in Figure 8 but power efficiency has been privileged. According to Figure 8 the optimal choice is thus a 85mm diameter propeller.

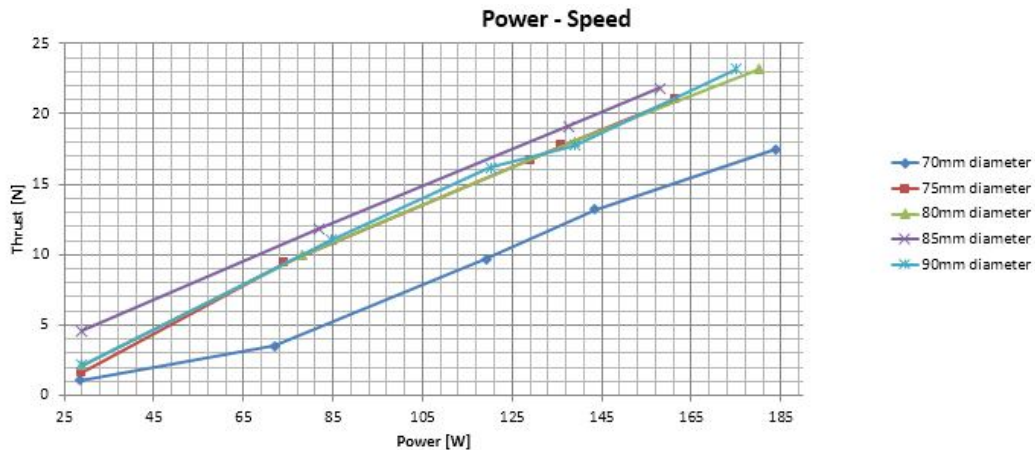

Figure 7 Delivered thrust as a function of the power absorbed by the motor for various propellers diameters.

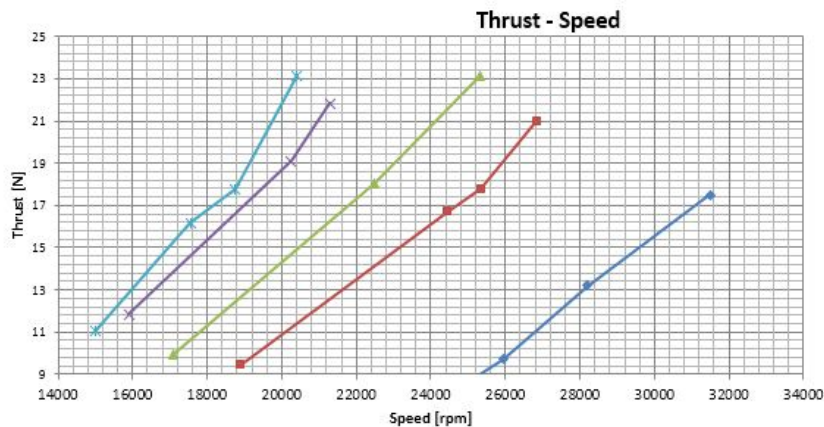

Figure 8 Delivered thrust as a function of the speed for various propellers diameters.

It is important to notice that thrust measurements of Figure 7 and Figure 8 were performed without a nozzle. By adding it, it is possible to obtain an increase in terms of thrust of a value which is between 20% and 30%, as shown in Figure 9. The same can be observed considering the thrust delivered by the propeller as a function of the power absorbed by the motor driver; in that case at a fixed current value, the use of nozzle causes an increase in terms of thrust of more than 100%.

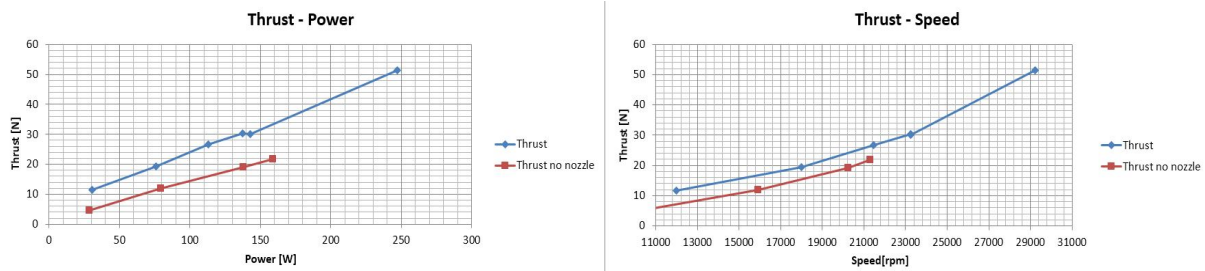

Figure 9 85mm diameter propeller. Thrust as a function of the power and of the rotor speed.

2.3 Experimental results on vertical and lateral thrusters

Vertical and lateral thrusters are incorporated in the hull of MARTA AUV as shown in Figure 1. This limits the water flow boosted by the propeller and makes impossible to design a proper nozzle in order to maximize the thrust. In these conditions a Ka-4-70 propeller would not be efficient: for this reason it has been designed a customized propeller like the one showed in Figure 10.

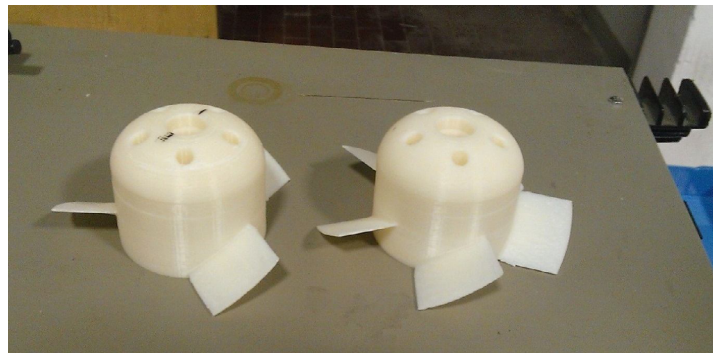

Figure 10 Thruster propellers.

To determine the optimal propeller geometry, various shapes have been tested, varying the number of blades and the p/d ratio. To simulate the effects of the hull, in which the propeller is incorporated, measurements have been taken with the propeller turning inside a tube. Measurement setup is shown in Figure 11. Due to the working conditions and to the particular shape of the propeller, it is difficult to achieve the thrust delivered by the Ka-4-70 propeller ducted with the nozzle. Figure 12 and Figure 13 show the thrust delivered by various configurations of the thruster propellers. According to Figure 13 the propeller which delivers the higher thrust for a given power is the 5 blades propeller with a p/d ratio of 1.4. It is also the one which delivers the highest thrust as a function of the speed.



Figure 11 Thruster measurement setup.



Figure 12 Thrust as a function of the rotor speed for various propellers configurations.

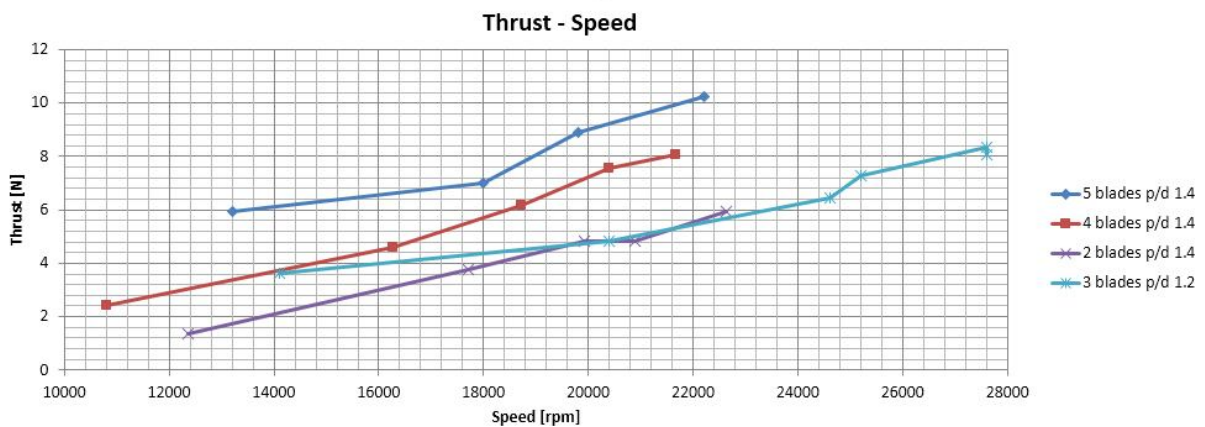

Figure 13 Thrust as a function of the electrical power for various propellers configurations.

3 CONCLUSIONS

The proposed testing system has proved to be very useful for the identification of the real performances of a commercial actuator, customized for the propulsion of small underwater vehicles (in particular for the design of MARTA AUV propulsion system). This is very important for the development of high performance actuators in the underwater robotics field since the performances of commercial motor and drives adapted for marine applications are typically quite different from the nominal ones. Thanks to this testing approach it has been possible to determine the optimal propellers parameters in order to maximize the propulsion efficiency in terms of power consumption and thrust.

ACKNOWLEDGMENT

This work has been supported and funded by the European ARROWS project, that has received funding from the European Union's Seventh Framework Programme for research, technological development and demonstration under grant agreement no 308724

REFERENCES

- [1] Allotta, B., Pugi, L., Bartolini, F., Ridolfi, A., Costanzi, R., Monni, N. and Gelli, J. Preliminary design and fast prototyping of an Autonomous Underwater Vehicle propulsion system, *Proceedings of the Institution of Mechanical Engineers, Part M: Journal of Engineering for the Maritime Environment*, 1475090213514040, 2014.
- [2] Allotta, B., Pugi, L., Bartolini, F., Costanzi, R., Ridolfi, A., Monni, N., Gelli, J., Vettori, G., Gualdesi, L. and Natalini, M., The THESAURUS project, a long range AUV for extended exploration, surveillance and monitoring of archaeological sites, *Computational Methods in Marine Engineering V - Proceedings of the 5th International Conference on Computational Methods in Marine Engineering*, 2013.
- [3] Di Corato, F., Fenucci, D., Caiti, A., Costanzi, R., Monni, N., Pugi, L., Ridolfi, A. and Allotta, B. Toward Underwater Acoustic-based Simultaneous Localization and Mapping. Experimental results with the Typhoon AUV at CommsNet13 Sea Trial, *Proceedings of OCEANS'14 MTS/IEEE St. John's Oceans, Saint John's (Canada)*, 14-19 September 2014.
- [4] Alvarez, A., Caffaz, A., Caiti, A., Casalino, G., Gualdesi, L., Turetta, A. and Viviani, R. Folaga: a low-cost autonomous underwater vehicle combining glider and AUV capabilities, *Ocean Engineering*, Volume 36(1), Pages 24-38, 2009.
- [5] Wenjuan, Qi, et al., Thermal analysis of underwater oil-filled BLDC motor, *Electrical Machines and Systems (ICEMS)*, 2011 International Conference on. IEEE, 2011.
- [6] Carlton J., *Marine propellers and propulsion*. 2nd ed., Elsevier, 2007.
- [7] Oosterveld M.W.C., Wake adapted ducted propellers, *Wageningen: Netherlands Ship Model Basin* (NSMB Publication No. 345), 1970.
- [8] Oosterveld M.W.C., Ducted propeller characteristics, *RINA symposium on ducted propellers*, London, 1973.
- [9] Allotta B. and Pugi L. *Meccatronica: Elementi di Trazione Elettrica*, Edizione Esculapio Bologna, ISBN: 9788874885855 DOI: 10.15651/978-88-748-8585-5, 2013.

- [10] Pivano L., Johansen T.A., and Smogeli ØN. A four quadrant thrust estimation scheme for marine propellers: theory and experiments, *IEEE Transactions on Control System Technology*, Volume 17(1), Pages 215–226, 2009.
- [11] Krishan, R. *Electric Motors and Drives*, Prentice Hall, 2009.