

SHIP VOYAGE ENERGY EFFICIENCY ASSESSMENT USING SHIP SIMULATORS

Ameen M. Bassam^{*†}, Alexander B. Phillips^{*}, Stephen R. Turnock^{*}, and
Philip A. Wilson^{*}

^{*}Fluid Structure Interactions Group
University of Southampton
Boldrewood Innovation Campus, SO16 7QF, UK
e-mail: ab2e12@soton.ac.uk, web page: <http://www.soton.ac.uk>

[†] Naval Architecture and Marine Engineering Department
Faculty of Engineering, Port Said University
Port Fouad, Post No: 42523, Egypt

Key words: Vessel Efficiency, Simulation, Matlab Simulink

Abstract. The increase in global trade is driving growth in both the size and number of ships. However, this increased demand is leading to greater contributions from shipping to air pollution. This is leading designers and operators to propose and adopt novel powering and propulsion systems. However, there is a challenge with assessing the actual benefit from using a certain retrofit technology or changing the operating conditions of their ships, this may be addressed using numerical simulations. This paper presents a time-domain one-degree of freedom ship simulator implemented in MATLAB/Simulink to enable designers to predict the performance of ship propulsion system during voyages.

The proposed simulator is used to assess the effectiveness of three different EEDI and SEEMP measures suggested by IMO to increase ship's propulsion system efficiency which are: voyage execution, slow steaming, and hybrid electric power and propulsion concepts using fuel cells. The developed simulator can be used for further studies and more elements are planned to be added to the ship simulators to make it more generic and capable of testing more propulsion configurations options.

1 INTRODUCTION

Much research in recent years has focused on increasing fuel efficiency of ships to reduce fuel consumption and emissions. According to the United Nations conference of trade and development (UNCTAD), over 80% of world trade by volume is handled by shipping. Increases in trade are driving growth in both the size and number of ships in the global fleet [1].

Consequently, energy demand from shipping is growing causing a rise in green house gases (GHG) emitted by ships. CO_2 emissions were estimated in a study by the international maritime organisation (IMO) where shipping is responsible for 3.3% of global CO_2 emissions [2] and about 20% of global NO_x emissions from all sources [3]. Moreover, compared to other transport modes, shipping has the highest SO_2 emissions due to the high sulphur content of marine fuel oil [4].

In order to control ships GHG, the IMO introduced emissions control areas (ECAs) with stringent international emission standards to control NO_x , SO_x , and PM emissions. In ECAs, ships must use fuels with a sulphur content of less than 0.1% which increases fuel cost for ships working within these areas. Regarding CO_2 emissions, the IMO published a package of technical and operational measures to be used by ships. These measures entered into force on 2013. An energy efficiency design index (EEDI) was made mandatory for all new ships of 400 gross tonnage and above requiring a minimum level of energy efficiency for different ship types and sizes. Also, a ship energy efficiency management plan (SEEMP) is required for all ships, which is an operational tool to improve energy efficiency of ships.

To attain the required level of ship energy efficiency, ship designers and builders can adopt the most suitable cost-efficient technologies of EEDI and SEEMP. However, it is necessary to assess the benefit from using certain technology or changing the ship's operational conditions and study its effect on ship performance, which can be done using numerical simulations.

In this work, a time-domain ship simulator with one-degree of freedom is presented which is capable of predicting ship performance taking into consideration weather conditions and ship hydrodynamic forces. This simulator is based on a building block modular approach where the ship hull, propeller and main parts of ship propulsion system is represented by separate submodels and implemented in a MATLAB/Simulink environment.

The developed ship simulator has been used to test the effectiveness of two SEEMP measures: voyage execution and slow steaming for a 46803 DWT double hull tanker. Another EEDI measure which is hybrid electric power concepts using fuel cells is tested using the developed simulator for an offshore supply vessel (OSV). Furthermore, this simulator can be modified and improved to be used to assess the benefits of other EEDI and SEEMP measures such as: optimized hull dimensions, waste heat recovery, engine efficiency enhancements and reduced auxiliary power measures.

2 SHIP SIMULATOR

Mathematical equations representing the ship components can be implemented with a graphical programming representation using blocks in MATLAB/Simulink environment. As can be seen in Figure 1, each block represents a component of the system such as the propeller or power plant. Input blocks are responsible for presenting data about the mission and the ship, such as: required speed (V), route weather, ship dimensions and its forms' coefficients. This data will be used to calculate the ship calm water resistance (R), added resistance due to wind and waves (ΔR), the ship's hydrodynamics coefficients

and added mass ($-X'_u$). Next, these forces are balanced with the thrust generated by the propeller (T_p) to calculate the actual speed of the ship which will be compared with the required speed to control the propeller speed (n_p) using a PID speed controller.

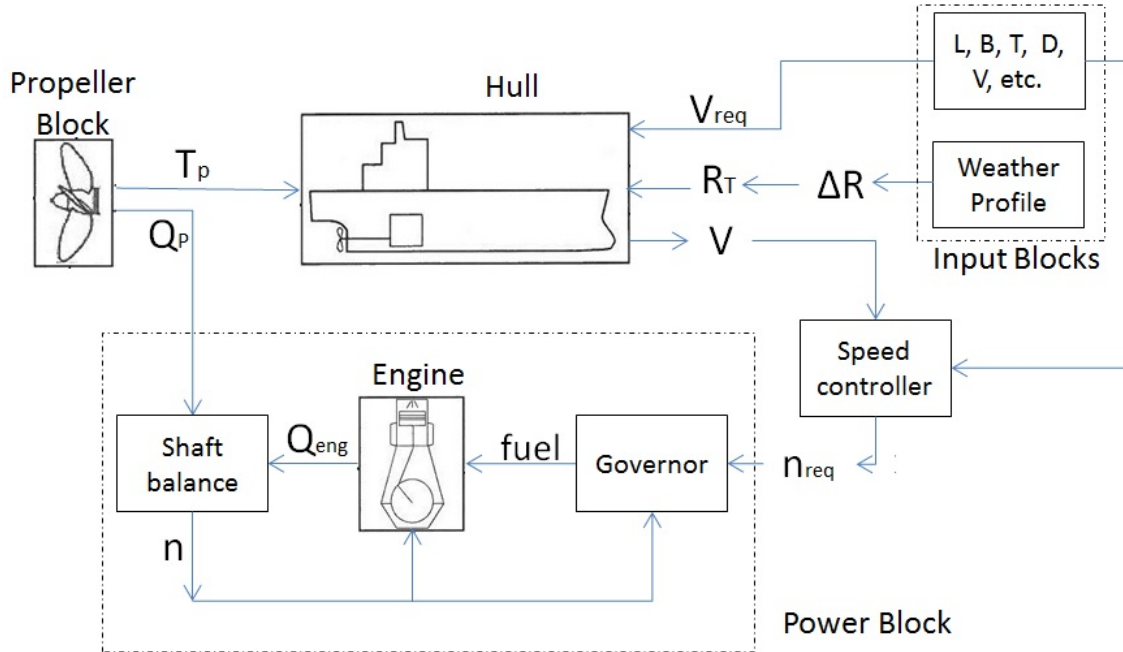

Figure 1: Overall ship simulator implementation in MATLAB/Simulink environment

The propeller required power is provided by the power block which can be: 2-stroke or 4-stroke diesel engine power plant or an electric motor powered by a fuel cell hybrid powering system. In the following sections, each block will be discussed in more detail.

2.1 Input data blocks

In order to perform the simulation, some inputs should be provided to the model by the user who simply will edit an input file with the new data. Then, the inputs values are fed to appropriate output ports automatically and will be passed between other blocks of the simulator. The required input data contains information about the ship, voyage, and the surrounding environment as shown in Table 1.

Table 1: Ship simulator required inputs

Ship dimensions and form coefficients, Bulbous bow, Number of bosses, brackets, thrusters.	Ship particulars
Required speed or propeller rpm, ship course angle	Mission data
Beaufort Number, weather angle, water temperature	Environment

Also, input data block enables the user to select between two modelling approaches, the forward facing model by using a predefined power profile in the form of engine speed or the backward facing model by using a predefined ship speed profile and the simulator calculates the required power [5].

2.2 Calm water resistance block

The basic approaches used to predict ship resistance can be resolved into experimental, empirical/statistical, and numerical approaches. For this study in order to predict ship calm water resistance, mathematical models which contain regression analysis equations are utilized because they can be readily implemented directly in simulation environment.

On the basis of range of application, publication date, and ease of programming, the method of Hollenbach [6] has been selected because of its relatively modern database, its wide range of applicability, it also needs less input parameters compared to the Holtrop-Mennen method [7] and is thus more appropriate at an early design stage.

2.3 Added resistance block

The prediction of added resistance due to wind and waves is of great importance in the design of ship propulsion system due to its adverse effect on voyage duration and consumed power. Added resistance may be estimated experimentally using wind tunnels and propulsion model testing or theoretically using hull pressure method, momentum and energy method, or radiated energy method [8].

In order to predict the speed loss due to added resistance at the early design stage, using simple approximate formulas is useful to estimate the effect of weather on the ship. The adopted formula in this simulator is proposed by Aertssen who performed regression analysis on ship performance data to estimate the speed loss percentage due to wind and waves derived from his analysis of full scale ship performance as shown in Equation 1 [9].

$$\frac{\Delta V}{V} = \frac{m}{L_{PP}} + n \quad (1)$$

where m and n vary with weather direction and Beaufort number and L_{PP} is length of ship between perpendiculars. Speed loss will be used to estimate the added resistance according to Equation 2.

$$\frac{\Delta V}{V} = \left[1 + \frac{\Delta R}{R} \right]^{1/2} - 1 \quad (2)$$

Verification of the added resistance block has been made where Aertssen's formulae was used in [12] to calculate the speed loss of a container ship with a length of 200 m, the added resistance block gives the same results as shown in Table 2.

Table 2: Verification of added resistance block

Beaufort Number	Speed loss % [12]	Simulation result %
5	6.1	6.091
6	11.9	11.91
7	20.5	20.55
8	34.4	34.36

2.4 Ship hydrodynamics block

This block is responsible for representing the interaction between the hull and the propeller in terms of wake fraction and thrust deduction and the interaction between the hull and the surrounding environment in terms of added mass. In this work, only the ship surge-surge added mass ($-X'_w$) is used to take into account the hydrodynamic forces resulting from ship longitudinal acceleration and it is calculated using Oltmann's semi-empirical equation as a function of ship block coefficient C_B and displacement (M) [10].

Outputs of ship hydrodynamics block also include mean wake (w) and thrust deduction (t) which estimation is of fundamental importance as it affects the propeller thrust and it should be determined along with the propeller speed, diameter, and power. At a preliminary design stage, detailed information about the ship is not available. So, regression equations are suitable to be used. For single screw ships, British Ship Research Association (BSRA) formula is selected to be used to calculate the wake fraction and thrust deduction [11]. For twin screw ships, wake fraction is calculated using Taylor's formula [12] and thrust deduction is calculated according to Holtrop and Mennen's formula [7]

2.5 Propeller block

The propeller block uses the previously estimated wake fraction, thrust deduction, ship speed, propeller speed, and data about the propeller as inputs to estimate the produced thrust (T_P) and torque (Q_P) which is calculated according to the following equations as a function of non-dimensional thrust K_T and torque coefficients K_Q , water density ρ , and propeller diameter D_p as follows

$$\begin{aligned} T_P &= K_T \cdot \rho \cdot n_p^2 \cdot D_p^4 \\ Q_P &= K_Q \cdot \rho \cdot n_p^2 \cdot D_p^5 \end{aligned} \quad (3)$$

where non-dimensional thrust and torque coefficients are calculated as a function of propeller advance ratio J using the following approximate equations for Wageningen B-screw series

$$\begin{aligned}\frac{K_T}{K_{T0}} &= \left[1 - \left(\frac{J}{a} \right)^c \right] \\ \frac{K_Q}{K_{Q0}} &= \left[1 - \left(\frac{J}{b} \right)^d \right]\end{aligned}\quad (4)$$

where coefficients a , b , c , and d 's values depends on propeller's blade area ratio and pitch ratio [12].

2.6 Forces balance and speed controller blocks

The resulting thrust from the propeller block is compared to the total resistance of the ship to calculate the ship's surge longitudinal acceleration taking into consideration the hydrodynamic forces resulted from this acceleration using Equation 5.

$$(M - X'_u) \frac{dv}{dt} = T_P(1 - t) - R - \Delta R \quad (5)$$

The acceleration is then integrated to calculate the current speed which is the main output of this block then it is compared against the required speed in the speed controller block which contains a standard PID controller that generates the required propeller rotational speed as a signal fed to the power block. PID controller is selected because of its simplicity, parameters' few number to be tuned and it has been used successfully in feedback control systems [13].

2.7 Power block

The power block is flexible and constructed in a way that facilitate the testing of different power sources including 2-stroke diesel engine, 4-stroke diesel engine, fuel cells, and batteries. The main inputs of the power block are the propeller torque and rotational speed. Transfer function models are used to model 2-stroke and 4-stroke diesel engines because engine torque is the only requirement in the developed simulator. For 2-stroke diesel engine, the marine diesel engine mathematical model developed by Bondarenko [14] as shown in Equation 6 is used.

$$\begin{aligned}\bar{Q} &= 0.5\bar{h}_p^{\frac{2}{3}} + 1.5\bar{h}_p^{\frac{1}{3}}\bar{n} - \bar{n}^2 \\ \bar{Q} &= \frac{Q}{Q_{mcr}}; \bar{h}_p = \frac{h_p}{h_{pmcr}}; \bar{n} = \frac{n}{n_{mcr}}\end{aligned}\quad (6)$$

where Q_{mcr} , h_{pmcr} , and n_{mcr} are the values of the engine torque Q , fuel flow rate h_p , and rotational speed n at the maximum continuous rating.

For 4-stroke diesel engine, the following transfer function is used [15].

$$\frac{Q}{Y} = \frac{K}{1 + Ts} \quad (7)$$

where Y is the fuel index, K is the gain constant and T is time constant. The second part of diesel engine dynamics describes the rotational motion and torque balance of the shaft as shown in Equation 8

$$2\pi I_m \dot{n}_s = Q_{eng} - Q_p - Q_f \quad (8)$$

where I_m is the inertia of rotating parts including the propeller and added inertia of the water, n_s is shaft speed, Q_{eng} is engine torque, Q_p is propeller torque, and Q_f is friction torque. Moreover, in this work the generic models included in the SimPowerSystems toolbox of Simulink [16] of fuel cell and battery are used in the developed simulator to simulate the performance of the fuel cell and battery. Therefore, the developed power block is flexible and can be used to test different power system configurations including diesel mechanical, diesel electric, and fuel cell/battery hybrid propulsion as shown in Figure 2.

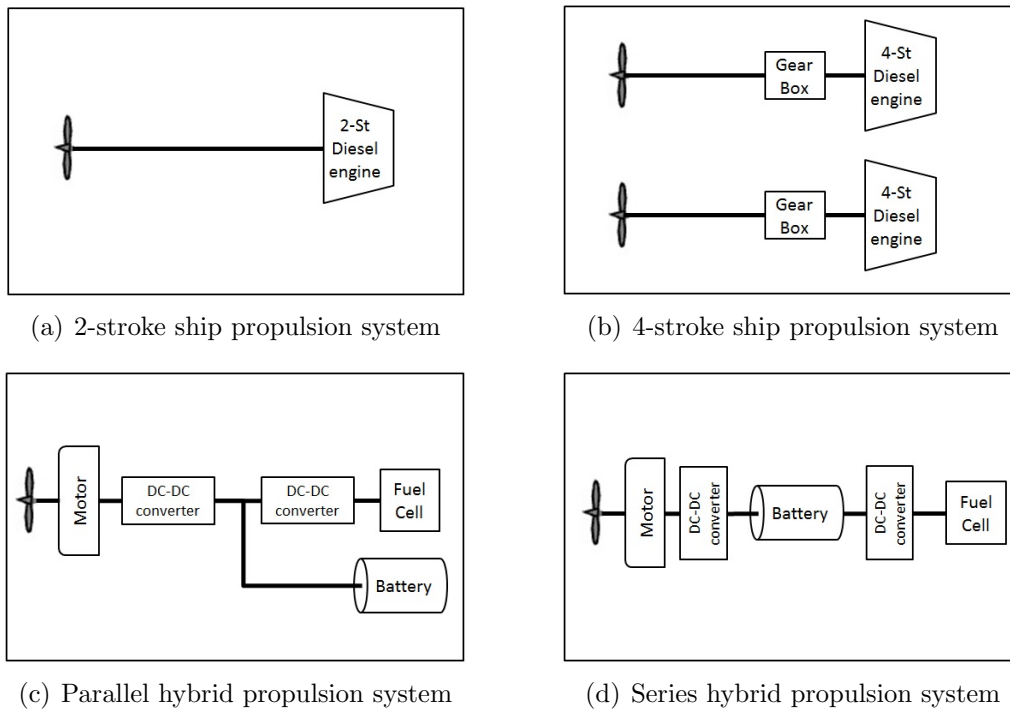

Figure 2: Mechanical ship propulsion systems

3 CASE STUDIES

3.1 Ship data

In the second IMO GHG study, tanker ship category had the highest fuel consumption [2]. Therefore, a single screw 46803 DWT double hull tanker utilising a 2-stroke diesel

engine with principal dimensions and data as listed in Table 3 has been selected to study voyage execution and slow steaming measures suggested by IMO. A 1/60th scale free running model has been developed for this vessel at the University of Southampton to study efficiency improvement methods for tankers through experimental work in towing tanks and lakes including naked hull tests, self propulsion tests, and bollard pull tests. Naked hull towing tank tests [17] are used to validate the developed resistance block as shown in Figure 3 where Froude traditional approach was used to scale up the model scale resistance results.

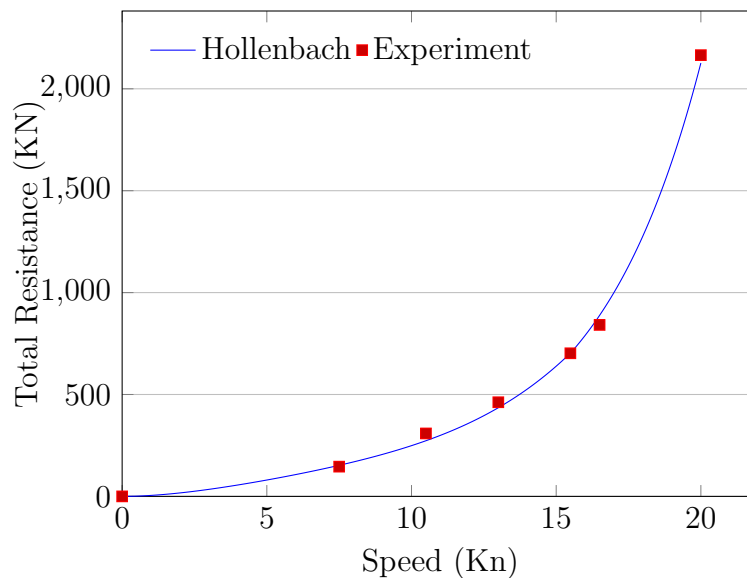

Figure 3: Validation of Hollenbach resistance method

Hybrid Electric Power and Propulsion Concepts using fuel cell is the third measure to be investigated in this study because using fuel cells in a hybrid electric propulsion will improve the energy efficiency and solve the emission problem in the short, medium and long term unlike the SEEMP measures which have effect on the short and medium term only. A twin-screw offshore supply vessel (OSV) using two 4-stroke diesel engines has been selected with principal dimensions and data as listed in Table 4 for this study because of its varying operational profile with high percentage of low speed operation which makes OSVs make the best use of electric propulsion systems.

3.2 Ship voyage simulation

For setting up the simulation of the examined ships, data of two real voyages were extracted from the automatic identification system (AIS) database [18] where ship's speed and location are saved during ship voyage. A predefined ship speed profile and propeller speed profile have been assumed according to saved missions data from AIS. Also, the real

Table 3: Specifications of the examined tanker

L_{OA}	183.33 <i>m</i>
L_{PP}	174 <i>m</i>
B	32.2 <i>m</i>
D	18.8 <i>m</i>
T	11.02 <i>m</i>
C_B	0.7994
D_P	6 <i>m</i>
Top speed	15 <i>kn</i>
Engine	1*11060 <i>kW</i> @ 127 <i>rpm</i>

Table 4: Specifications of the examined OSV

L_{OA}	53.8 <i>m</i>
L_{PP}	48.8 <i>m</i>
B	13.8 <i>m</i>
D	4.5 <i>m</i>
T	3.6 <i>m</i>
C_B	0.66
D_P	2.16 <i>m</i>
Top speed	11.5 <i>kn</i>
Engine	2*1174 <i>kW</i> @ 1800 <i>rpm</i>

weather conditions corresponding to the two examined missions have been extracted from the global forecast system (GFS) database [19] and used as an input to the simulation.

4 RESULTS

4.1 Voyage execution

This SEEMP measure explores the improvement of voyage planning and execution. It includes different ship operational modes, optimum route, reducing port time and long ballast voyages. In order to increase the profitability, ship owners operate vessels at a predefined high speed to increase number of freights per year which is considered as a constant speed mode of operation which may increase power requirements and fuel consumption especially during harsh weather.

Another way to operate ships is using constant propeller speed mode of operation to have the minimum specific fuel consumption of the engine which can be more efficient however weather conditions may cause a speed loss and late arriving of the ship resulting in additional cost which could be more than fuel saving. The developed ship simulator has been used to compare between these two modes of operation for the examined tanker during a real single voyage.

Two predefined profiles of ship speed and propeller speed have been assumed and used as inputs to two separate simulations to perform the same voyage distance under the same real weather parameters. Results show that adopting constant ship speed mode of operation for the considered voyage results in earlier arrival and saving in voyage time by 4% which means more freights per year. However, adopting constant propeller speed mode leads to lower fuel consumption (tonnes) by 2% and lower fuel consumption rate (tonnes/day) of 6%.

4.2 Slow steaming

Speed reduction or slow steaming is another SEEMP measure and it aims to reduce GHG through reducing ship speed since consumed power can be assumed as a cubic function of ship speed. However, it will increase voyage duration. For the same tanker, different simulations are performed with a different speed each time to perform the same voyage assuming an average constant auxiliary power of 750 kW . Simulation results reveal that reducing ship speed by about 44% will result in fuel consumption saving of 46% as shown in Figure 4.

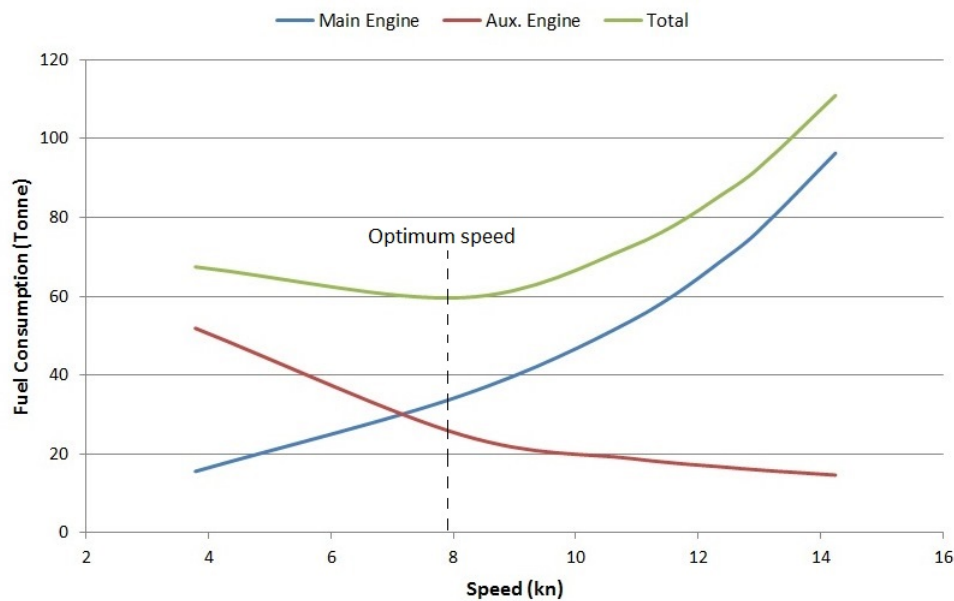

Figure 4: Total fuel consumption of main and auxiliary engines for the examined voyage

As illustrated in Figure 4, auxiliary power fuel consumption decreases with higher speed because time of voyage is decreasing. On the other hand main engine fuel consumption increases with higher speed which gives an indication about optimal speed for least fuel consumption assuming constant auxiliary power of 750 kW . Assuming higher auxiliary power affects optimal speed because while reducing ship speed, auxiliary power fuel consumption increases which requires higher optimal speed. As shown in Figure 5, the optimal speed for least fuel consumption increases from about 7.9 kn to 9.5 kn when the auxiliary power increase from 750 kW to 2000 kW .

4.3 Hybrid electric power and propulsion concepts

According to the operating requirements of the OSV: torque, thrust, power and propeller angular velocity, a DC motor is selected because of its: wide range of speed and torque, low cost and less complex control system [20]. In order to size the required power

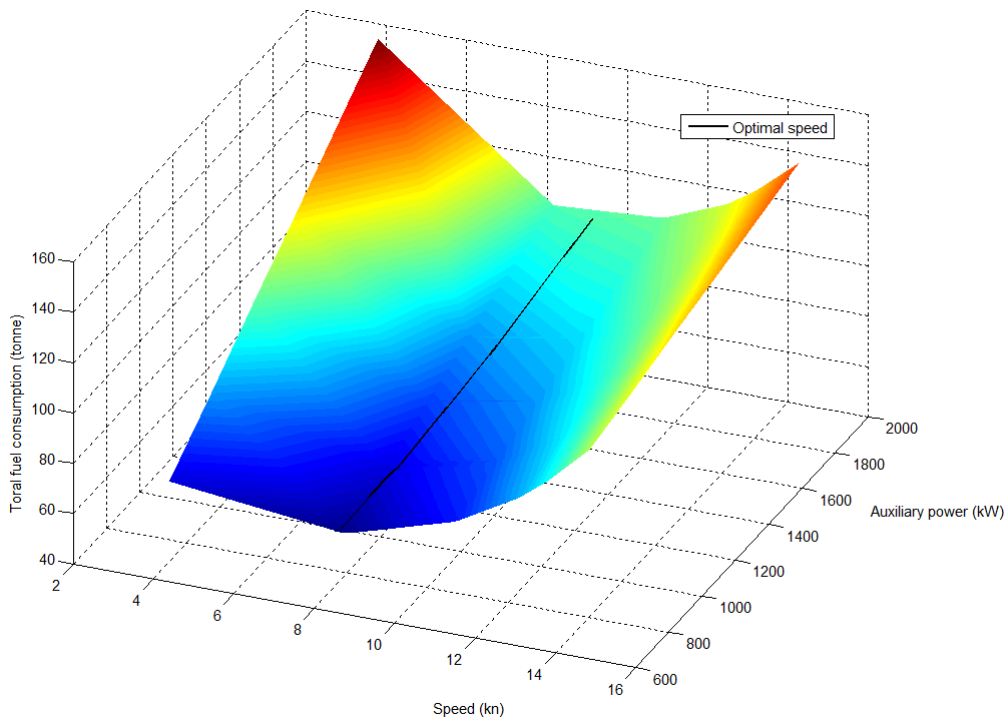

Figure 5: Auxiliary power effect on the optimal speed for the examined voyage

of fuel cell and batteries, it is assumed that fuel cells will supply the average required power while batteries will supply peak power and will be recharged during low power demand as shown in Figure 6. An energy management strategy (EMS) has been developed as well to manage the power flow from fuel cells and batteries in a way that maximize fuel cell efficiency and reduce its consumption which is not the main focus of this work.

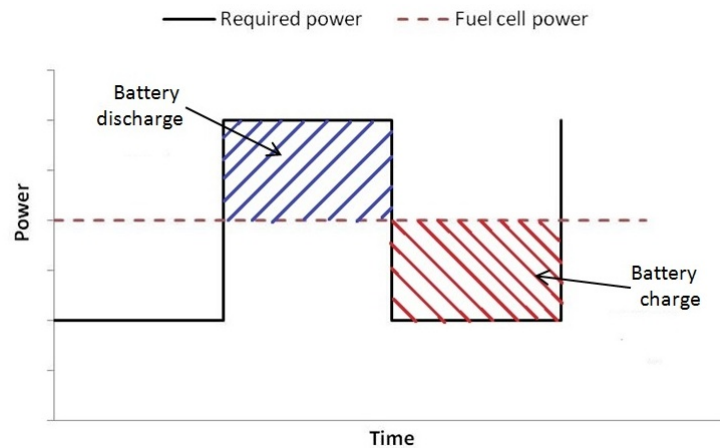

Figure 6: A generic power profile

For the examined OSV's mission, the 4-stroke diesel engines are replaced by two fuel cells with a total power of 100 kW, lithium-ion batteries to supply the peak power, and two electric motors while the same gearbox will be used. Changes in the developed simulator will happen only to the power block where the diesel engines block will be replaced with fuel cells block, battery block, DC motors block and EMS block as shown in Figure 7. However the overall power block will have the same inputs and outputs in both cases.

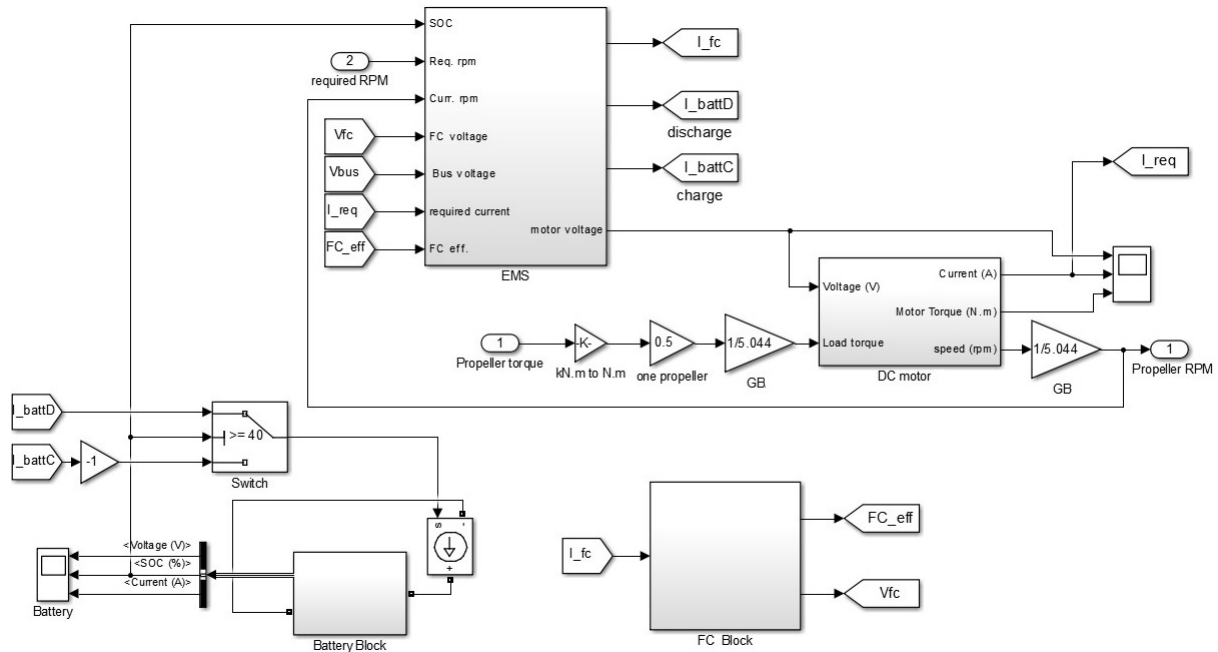

Figure 7: Power block of hybrid fuel cell system

This will result in a volume saving of 42% with less than 1% more weight required by the hybrid fuel cell system and it will eliminate the emission problem because of hydrogen clean carbon footprint but the first cost will be higher. However, taking the consumed fuel and hydrogen into consideration, volume and weight of the proposed hybrid fuel cell battery system will be higher than the current system due to required volume and weight of hydrogen storage system as shown in Table 5.

5 CONCLUSION

In summary, A time-domain one-degree of freedom ship simulator is presented. The developed simulator has been used to study SEEMP measures of voyage execution and slow steaming for a tanker ship and study EEDI measure of hybrid electric power and propulsion concepts using fuel cells for an OSV. The investigation showed that operating ship with constant speed reduces voyage time while adopting constant propeller speed results in less fuel consumption but with an associated time penalty. Also, reducing ship

Table 5: Diesel engines compared to hybrid fuel cell system for the examined OSV

	Weight (tonne)	Volume (m^3)	cost (\$)
Diesel propulsion system			
4-stroke diesel engines	13.064	28.424	645700
fuel	1.8287	1.945	915
Total	14.8927	30.369	646615
Hybrid fuel cell system			
Fuel cell	0.375	0.66	220000
Battery	8.885	4.44	888500
Motors	3.9	11.12	212850
Hydrogen	3.183	45	2283
Total	16.343	61.22	1323633

operational speed can minimise fuel consumption however there is a limit for slow steaming before fuel consumption starts to increase due to speed invariant power requirements.

The developed simulator is generic and have shown flexibility since it can be used to study mechanical and electrical propulsion systems using different power sources such as 2-stroke and 4-stroke diesel engines, fuel cells and batteries. However the developed simulator is valid within limits of the used mathematical models. The developed simulator is promising and can be used as decision support tool by ship companies and designers and it should be validated with real ship operational data. Future work includes adding another calm water resistance method and writing a MATLAB code to download weather parameters automatically rather than put it manually.

REFERENCES

- [1] *Review of Maritime Transport 2013*. United Nations Conference on Trade and Development (UNCTAD), (2013).
- [2] *Second IMO GHG Study 2009*. International Maritime Organization, (2009).
- [3] S. Kollamthodi, C. Brannigan, M. Harfoot, I. Skinner, C. Whall, L. Lavric, R. Noden, D. Lee, vind Buhaug, K. Martinussen, R. Skejic, I. Valberg, J. C. Brembo, V. Eyring, and J. Faber, *Greenhouse gas emissions from shipping: trends, projections and abatement potential:Final Report*, (2008).
- [4] V. Eyring, H. W. Köhler, J. van Aardenne, and A. Lauer, "Emissions from international shipping: 1. The last 50 years". *Journal of Geophysical Research* (2005) **110**:1984–2012.
- [5] C. Musardo, G. Rizzoni, Y. Guezennec, and B. Staccia, "A-ECMS: An adaptive algorithm for hybrid electric vehicle energy management". *European Journal of Control* (2005) **11**(4):509-524.

- [6] K. Hollenbach, "Estimating resistance and propulsion for single-screw and twin-screw ships". *Ship Technology Research* (1998) **45**:72-76.
- [7] J. Holtrop and G. Mennen, "An Approximate Power Prediction Method". *International Shipbuilding Progress* (1982) **29**:166-170.
- [8] F. Perez Arribas, "Some methods to obtain the added resistance of a ship advancing in waves". *Ocean Engineering* (2007) **37**(7):946-955.
- [9] G. Aertssen, "Service performance and trails at sea". *Report of Performance Committee*, 12th ITTC, Appendix V (1969) 210:214.
- [10] P. Oltmann, "Identification of Hydrodynamic Damping Derivatives - A Pragmatic Approach". *Proceedings of The International Conference on Marine Simulation and Ship Manoeuvrability*, Japan (2003).
- [11] M. N. Parker, "The B.S.R.A. Methodical Series-An Overall Presentation". *Transactions of the Royal Institution of Naval Architects* (1966) **108**:389-393.
- [12] A. F. Molland, S. R. Turnock, and D. A. Hudson. *Ship Resistance and Propulsion: Practical Estimation of Propulsive Power*. Cambridge University Press (2011).
- [13] A. Visioli, *Practical PID Control*. Springer (2006).
- [14] O. Bondarenko, M. Kashiwagi, and S. Naito "Dynamics of diesel engine in the framework of ship propulsion plant". *Proceedings of the Japan Society of Naval Architects and Ocean Engineers* (2009) **8**:335-338.
- [15] M. Horigome, M. Hara, T. Hotta, and K. Ohtsu "Computer Control of Main Diesel Engine Speed for Merchant Ships". *Proceedings of ISME (Kobe90)*, Japan (1990).
- [16] SimPowerSystems <http://uk.mathworks.com/products/simpower/?refresh=true>.
- [17] E. Anderlini, H. Crossley, J. Hawkes, H. Le, J. Mozden, K. Neale, and B. Thornton "The Development of an Autonomous Self-Propulsion Vessel for Powering and Manoeuvring Tests in an Uncontrolled Environment". *University of Southampton* (2013)
- [18] AIS <https://www.marinetraffic.com/en/>.
- [19] GFS <http://www.ncdc.noaa.gov/data-access/model-data/model-datasets/global-forcast-system-gfs>
- [20] R. Gupta, R. Lamba, and S. Padhee "Thyristor Based Speed Control Techniques of DC Motor: A Comparative Analysis". *International Journal of Scientific and Research Publications* (2012) **2**(6).