



TITLE:

A Resonance Type Magnetometer

AUTHOR(S):

Kumagai, Naoiti; Kawai, Naoto

CITATION:

Kumagai, Naoiti ...[et al]. A Resonance Type Magnetometer. Memoirs of the College of Science, University of Kyoto. Series B 1953, 20(4): 307-309

ISSUE DATE:

1953-12-10

URL:

<http://hdl.handle.net/2433/257983>

RIGHT:

A Resonance Type Magnetometer*

By

Naoti KUMAGAI and Naoto KAWAI

Geological and Mineralogical Institute, University of Kyoto

(Received Aug. 12, 1953)

Abstract

A sensitive astatic magnetometer is designed and manufactured. By this apparatus, it is able to measure the natural remanent magnetic polarization of rocks and that of small single grain of rock forming ferromagnetic material. The specimen piece is rotated at a place in front of the magnetometer with an angular velocity strictly equal to the phase velocity of free oscillation of the magnetometer. And the measurement is carried out in its resonance state with the alternative magnetic field due to the specimen dipole. The determinable polarization of rock specimen is as small as 10^{-8} C. G. S. per cc. The smallest grain of natural magnetite whose remanent polarization is sufficiently measurable, is 300μ in diameter. The brief description of the measuring device and its principle are dealt with.

For measuring remanent magnetic polarization of rock specimens, a particular type of magnetometer has been designed. This is a quasi-astatic magnetometer with double magnets** which are fixed on both ends of an aluminum hollow cylinder by means of holders in opposite magnetic direction to each other, the cylinder being 25 cm in length and 0.2 cm in diameter (Fig. 1). This magnet system is suspended by a thin phosphor-bronze wire (S.W. 50) of 100 cm in length and provided with a copper damper. Total weight of the whole system including the holders and a reflecting mirror is less than 3 grams. In order to obtain the astatic condition, adjusting screws are attached to the magnet holder. By these screws the upper or compensating magnet can be rotated in horizontal plane and the lower or working magnet in vertical plane. By means of these adjustments it is possible to produce a resultant magnetic moment of the system of two magnets in any amount and in any direction, thus giving rise to certain incompleteness in the astaticity.

A very high sensitivity is attained, when the resultant moment, say m , produced in the direction perpendicular to that of the moment of the working magnet, is oriented in the direction antiparallel to the geomagnetic horizontal component

* Detailed paper will be published on another occasion.

** N. S. K. I. magnet of 0.4 cm in diameter, 1.3 cm in length, $Hc=600$ Oe., and $Br=1100$ Oe. for infinite length.

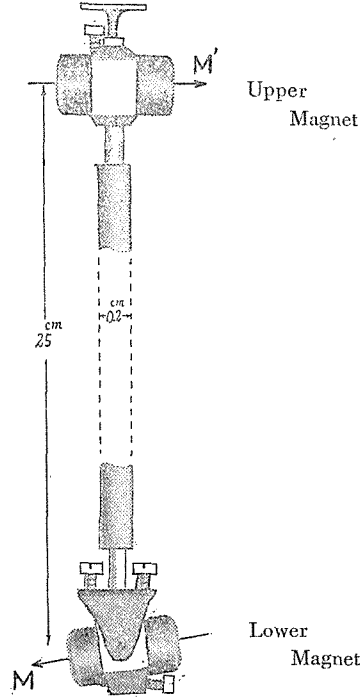

Fig 1. M' : Moment of upper magnet
 M : Moment of lower magnet

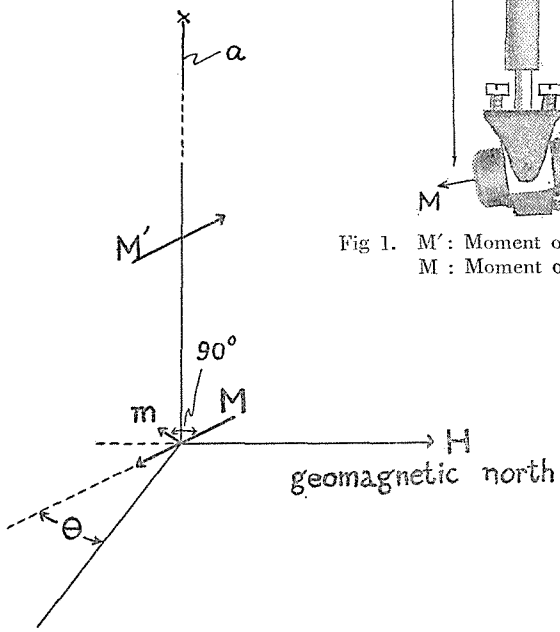

Fig 2. m : resultant moment
 a : phosphor-bronze torsion wire

H , when the system is in the equilibrium position (Fig. 2). This equilibrium is obtained, if the value of m is made such that the couple $mH\sin\theta$ is less than the restoring couple $\tau\theta$ of the phosphor-bronze torsion wire, when the magne-

tometer is assumedly deflected by an angle θ , τ^\dagger being the constant of the wire. This condition is satisfied when $m < \tau/H$. Sensitivity of the magnetometer thus adjusted can be raised to several times that of a perfectly astaticized one.

We can easily measure direction and magnitude of a very weak magnetic polarization of a rock specimen, when the above mentioned magnetometer is used as described in the following. The specimen is placed in front of the working magnet and is rotated around a vertical axis with an angular velocity whose period is equal to that of the free oscillation of the magnetometer until it will acquire a resonance oscillation. When the resonance state is attained, the phase angle of the magnetometer oscillation retards by an amount equal to $\pi/2$ from that of the rotation of the magnetic dipole of the specimen, that is, at the instance when the position of the vector of the dipole coincides with the magnetic meridian, the magnetic axis of the working magnet lies in the direction perpendicular to the magnetic meridian. This condition enables one to find the direction of the horizontal projection of the dipole vector with respect to the coordinate axes fixed to the specimen. On the other hand, the magnitude of the polarization can be obtained by comparing the observed amplitude of the resonance oscillation of the magnetometer with the amplitude caused by a standard sample of known polarization.

When our quasi-astatic magnetometer is used in the resonance state as described above, the determinable limit of the magnitude of magnetic polarization is 10^{-8} C. G. S. e. m. u. per cc. with the specimen of 5 cm cube in volume placed at a distance of 10 cm from the working magnet. The observational error in the magnitude of polarization is in several percentages or more and the mean error in the direction of it in several degrees. Extremely high magnification can not be attained in amplitude, owing to the instability called forth in the resonance state, and therefore, a copper damper is used for getting a suitable magnification.

† $\tau=0.04$ C. G. S.