



TITLE:

The 40/70/120 cm Schmidt Telescope

AUTHOR(S):

Imagawa, Fumihiko; Kawai, Seiichi; Tsujimura, Tamiyuki; Ohtani, Hiroshi; Hirata, Ryuko

CITATION:

Imagawa, Fumihiko ...[et al]. The 40/70/120 cm Schmidt Telescope. Memoirs of the Faculty of Science, Kyoto University. Series of physics, astrophysics, geophysics and chemistry 1977, 35(1): 185-195

ISSUE DATE:

1977-09

URL:

<http://hdl.handle.net/2433/257564>

RIGHT:

THE 40/70/120 cm SCHMIDT TELESCOPE

By

Fumihiko IMAGAWA*, Seichi KAWAI**, Tamiyuki TSUJIMURA*,
Hiroshi OHTANI* and Ryuko HIRATA*

Department of Astronomy, Faculty of Science, Kyoto University, Kyoto

(Received August 1, 1976; revised August 10, 1976)

ABSTRACT

A 40/70/120 cm Schmidt telescope was constructed in May 1972. The telescope has the following two characteristics.

- (1) The vignetting free field is especially wide ($7^\circ.1$) compared with the usual Schmidt telescopes of the similar class to ours.
- (2) The telescope is designed to be used not only for the usual Schmidt type, but also for a quasi-Cassegrain type.

We succeeded in construction of a plate holder in which photographic plates are bent in contact with the spherical surface with the radius of curvature of 120 cm.

A short description on the optical and mechanical systems is presented with some results of test observations.

A 40/70/120 cm Schmidt telescope of our institute was constructed in May 1972. A short description of the telescope and some results of test observations with it are presented here. The telescope was at first mounted in Fukuchiyama, seventy kilometers north-west of Kyoto City, and is to be moved to Ouda, fifty kilometers south-east of Osaka City, in the near future.

This telescope is so designed as to be able to be used also for a quasi-Cassegrain type, to which we will mention briefly in Appendix.

1. Optical System

We designed our optical system in consideration of the next two points. The first point is to make the vignetting free field as wide as possible rather than to make F-ratio small, in order to meet our observational demands for taking photograph of a large field object such as a cluster of galaxies on a single plate. The second is to keep the size of aberration images within the grain size of photographic emulsion over the whole wavelength range $\lambda\lambda$ 3500–8500 Å by a single correcting plate. Examinations of the image quality were carried out with the aid of spot diagrams (Kawai and Kogure 1968). The adopted system is shown in Figure 1. The wide vignetting free field of $7^\circ.1$ is a distinguished characteristic of our Schmidt telescope.

The surface profile of the correcting plate is shown in Figure 2. The e-line (5461Å) was adopted as the basic wavelength. The choice of the wavelength is

* Department of Astronomy, Faculty of Science, Kyoto University, Kyoto

** Division of Applied Physics, Government Industrial Research Institute, Osaka

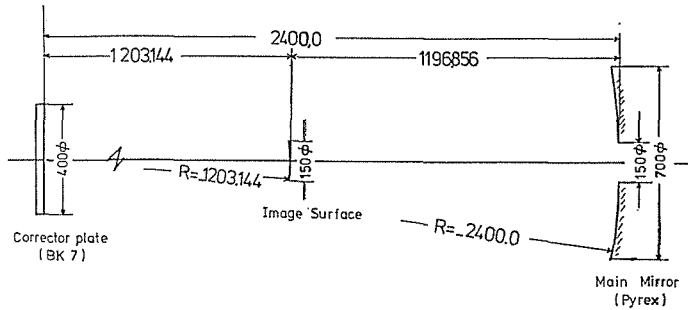

Fig. 1. Optical system of the Schmidt telescope. Numerical values are in unit of mm.

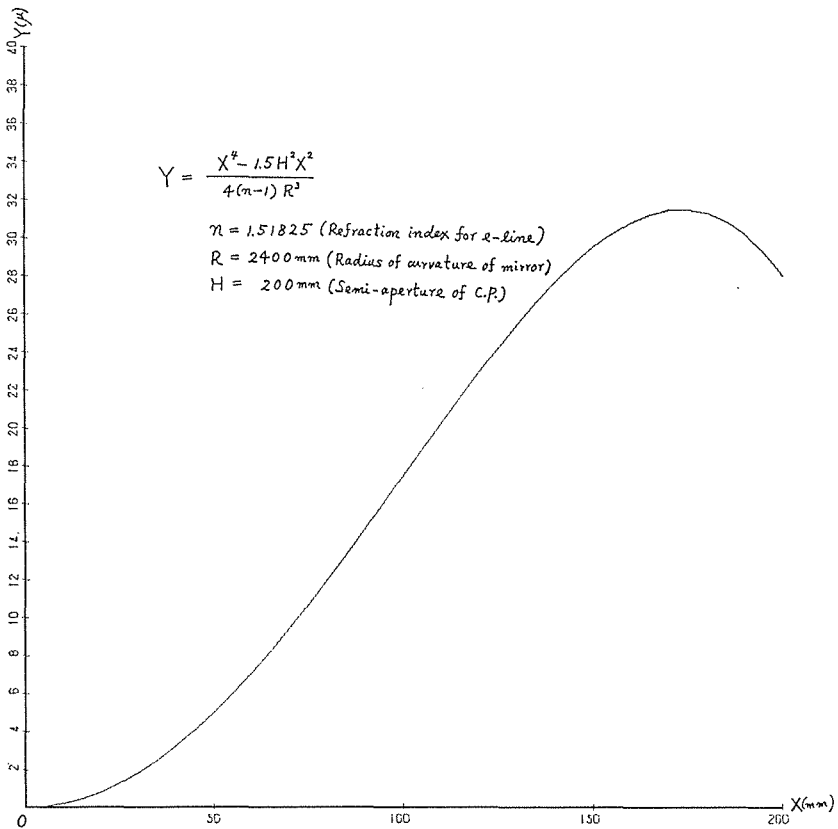

Fig. 2. Surface profile of the correcting plate. The origin O in the graph is the vertex of the plate.

due to the fact that confusions of images caused by the chromatic aberration are similar at both ends of the wavelength range $\lambda\lambda$ 3500–8500 Å, and is also due to the easiness of optical tests in laboratory. Figure 3 shows the spot diagrams of a point source for various wavelengths and for semi-field angles 0°, 2°, and 3°.5.

Next, let us consider the confusions of the image due to malalignments of the optical parts and the error in the focal surface. Investigations by spot diagrams

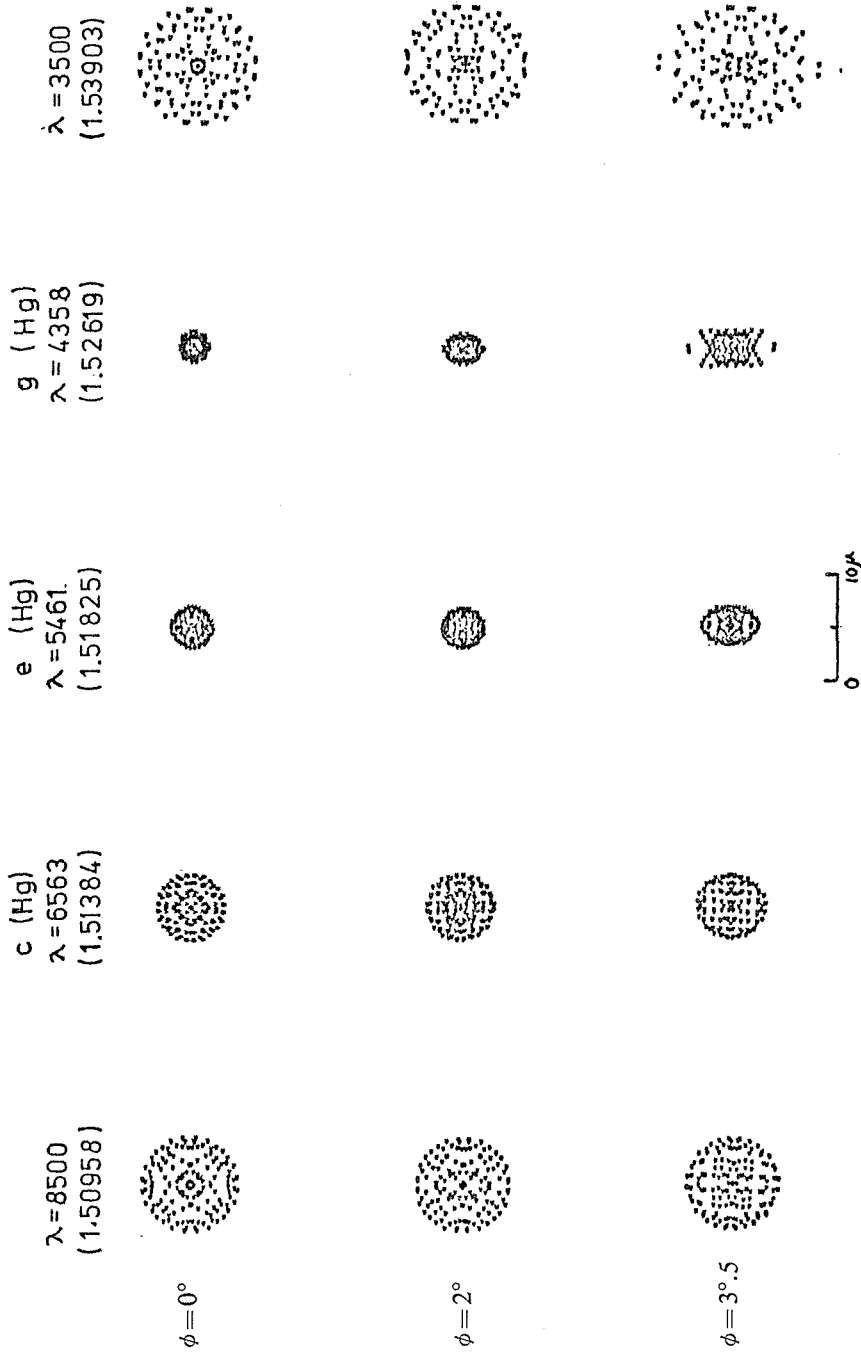

Fig. 3. Spot diagrams of the Schmidt system for various wave lengths. Numbers in parenthesis denote the refraction indices for each wavelength. ϕ 's are the semi-field angles. Basic wave length is 5461 Å (e-line).

led us to the following conclusions (Kawai and Imagawa 1972; Imagawa and Tsujimura 1976).

- (1) The position of the focal surface should be adjusted within an accuracy of $10\ \mu$.
- (2) It is desirable to adjust the position of the correcting plate within ± 2 mm from the center of curvature of the mirror.
- (3) It is necessary to adjust the discordance of optical axis of the correcting plate with that of the main mirror within an accuracy of 0.2 mm.
- (4) The focal surface of the plate holder should be constructed within an accuracy of ± 20 mm around the theoretical radius of curvature.

The data of the optical system together with those of the objective prism are shown in Table 1.

Table 1. Data of the optical system

Main Mirror	
Effective diameter	70 cm
Thickness at the center	9 cm
Radius of curvature	240 cm
Weight	77.5 kg
Material	Pyrex
Correcting Plate	
Effective diameter	40 cm
Thickness	1.8 cm
Weight	7 kg
Material	BK7
Focal Part	
Radius of curvature of focal surface	120.3 cm
Size of plate	16×16 cm
Vignetting free field	$7^{\circ}.1 \approx 14.9$ cm
Scale on plate	172"/mm
Objective prism	
Effective diameter	40 cm
Thickness Max.	5.5 cm
Min.	2.0 cm
Angle of vertex	5°
Weight (including cell)	30 kg
Material	LF5
Dispersion at $H\gamma$	$487\text{\AA}/\text{mm}$

2. Mechanical system

A general view of the telescope is shown in the accompanying plate. Mounting is of the usual fork type. Particular attentions are paid on the following items on the design and construction of the mechanical system.

a) The supporting mechanism of the main mirror is similar to that used for the Baker-Nunn Schmidt telescope, to give neither deformation nor displacement to the main mirror at any position of the telescope.

b) In order to compensate automatically changes in focal length due to changes in air temperature, three super-invar rods are provided between the main mirror and the plate holder carriage.

c) Bearing in mind the usage for quasi-Cassegrain type, the main tube is made cylindrical instead of conical and the arms of the fork are made long enough to be able to set a photometric or spectroscopic apparatus behind the main mirror cell. Therefore, special cautions were paid on the stability of the fork.

d) The adjusting mechanisms of the optical system including that of the tilting of the plate holder are made to satisfy the conclusions obtained in the previous section.

The data of the mechanical system are in Table 2.

Table 2. Data of the mechanical system

Telescope Tube	
Weight	2 t
Length (including dew cap)	375 cm
Diameter	100 cm
Super-invar rod	
Diameter	9 mm
Length	120 cm
Expansion coefficient	2×10^{-7} per degree
Fork	
Weight (including polar axis)	3 t
Length of arm	230 cm
Clearance between main mirror cell and fork on polar axis	80 cm
Bending of polar axis and arm	Within $10''$ at any hour angle and declination
Driving Mechanism	
Sidereal drive	
Stability	10^{-5} utilizing 60 Hz of city source
Positional drive	
Quick	$40^\circ/\text{min}$
Slow	$1^\circ/\text{min}$
Fine I	$10''/\text{sec}$
Fine II	$5''/\text{sec}$
Trail	$0''2-2''/\text{sec}$ (continuously variable)

3. Plate holder

It is a matter of course that the Schmidt plate must be bent unless a flattener lens, which makes the image quality poorer, is inserted. Bending of thin glass plate in contact with a spherical surface, whose radius of curvature is 120 cm as in our case, is almost near the limit of elasticity. The critical point of rupture which is different from plate to plate, depends on invisible cracks and defects in glass caused by inhomogenities of the material, which are more serious in larger plates.

As far as we know from communications with many observatories, the film is used or the flattener is inserted without exception when the focal length is shorter than 120 cm. The telescope at Bosscha Observatory has the shortest focal length (127 cm) among the Schmidts where the plate is used without a flattener.

After several experiments and improvements of pressing mechanism of plates,

we succeeded in construction of the plate holder now used. Its diagram is shown in Figure 4. The pressure strength by the spring ④ in the figure is 20 kg. The percentage of rupture of plates within two or three hours after loading is about 10, when Kodak plates with thickness of 0.030 inches are used. We intend to decrease the rate of rupture further by future improvements.

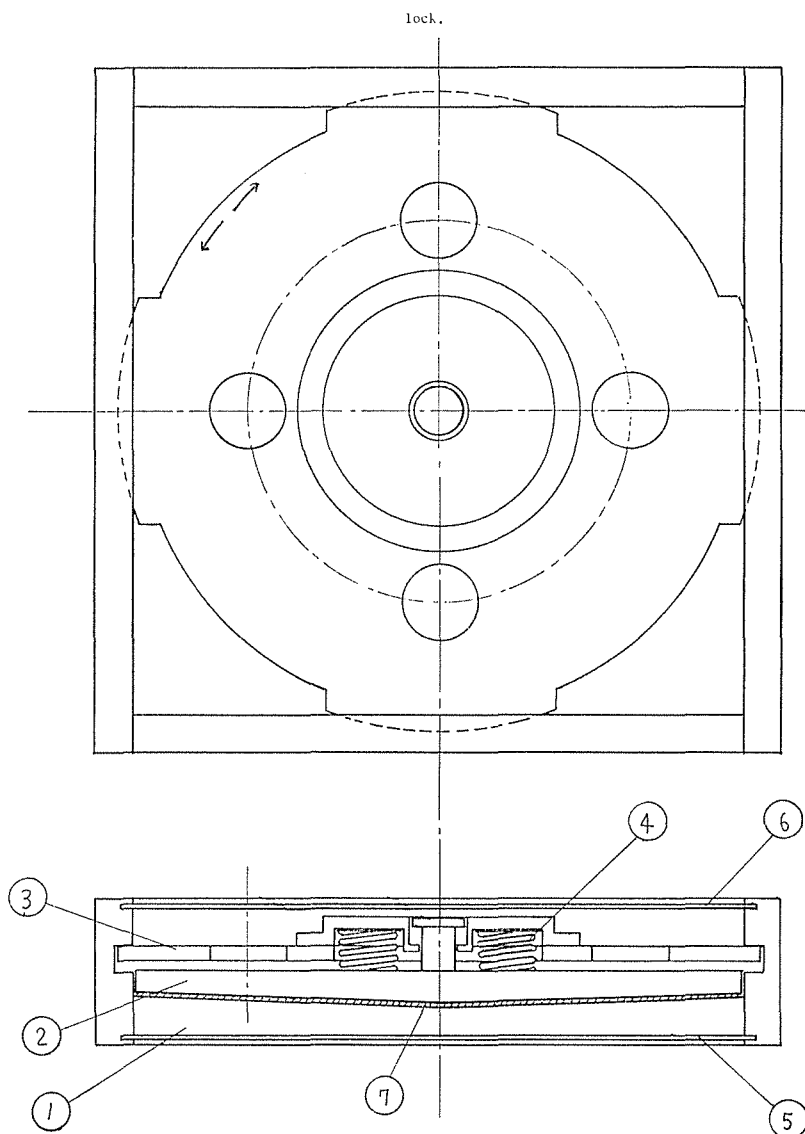

Fig. 4. Design diagram of the plate holder.

- | | |
|--------------------|-----------------------|
| 1) Concave surface | 5) Slide shutter |
| 2) Convex surface | 6) Rear lid |
| 3) Locking plate | 7) Photographic plate |
| 4) Spring | |

One presses down the locking plate and turns it in the direction of arrows to lock.

We had also made a film holder, but it was found difficult to load the film closely to the curved surface of the holder by means of a simple mechanical presser. In addition, there is another difficulty in using the film, that the minimum quantity of order for Kodak films is too much.

4. Test Observations

Examinations of the optical system were carried out mainly by the Hartmann method by stars. The Hartmann constant is 1.4. The minimum star image is as small as 25μ in diameter, on 103 a-E plates without filter.

We performed some test observations for detecting the field error and plate error in stellar photometry. We adopted a method by widely extended open clusters such as Hyades or Coma Berenices, which include many photoelectric standard stars. In this method, no considerations are necessary concerning changes of sky condition during exposures and differences of photographic processings. Calibration curves for the standard magnitude V against the iris-photometer reading of star image are obtained for 1) all standard stars contained in the field, 2) the standards within semi-field angle 2° and 3) between 2° and $3^\circ.5$ from the plate center. Supposing the calibration curve to be a second order polynomial within a six magnitudes interval, we get the least square solutions, one of which is illustrated in Table 3. The letters a , b and c denote coefficients of the polynomial.

Table 3

	a	b	c	m.e. of V
1)	0.020 ± 0.0011	-1.497 ± 0.064	31.56 ± 0.88	± 0.18
2)	0.020 ± 0.0015	-1.502 ± 0.086	31.62 ± 1.2	± 0.19
3)	0.020 ± 0.0016	-1.501 ± 0.089	31.61 ± 1.2	± 0.15

Three curves almost coincide with one another. Field errors are at most 0.03–0.04 magnitudes, which are very satisfactory.

The above observations were performed by films when the plate holder was not yet accomplished. Films used are Kodak XXX and the filter is Fuji SC 50 which sharply cuts the wavelength region shorter than 5000 \AA . Therefore, our system does not rigorously correspond to the standard V . If a suitable combination of emulsion and filter is adopted, photometric errors are expected to be reduced.

Next, we took photographs of the Virgo cluster of galaxies as a preliminary observation utilizing the wide unvignetted field, and performed microphotometer tracings along the major and minor axes of some member galaxies, one of which is illustrated in Figure 5. The figure shows the density distribution along the major axis of NGC 4486 (M87) photographed on a Kodak 103 a-E plate with a Fuji filter SC58 which sharply cuts the shorter wavelengths than 5800 \AA . Numbers in parentheses shown on the mean density curve denote the surface brightness expressed in magnitude estimated by comparing the results of Markaryan et al. (Markaryan et al. 1965).

The authors wish to express their hearty thanks to the retired Professor T. Shimizu and Professor I. Kawaguchi for their constant encouragement. Their

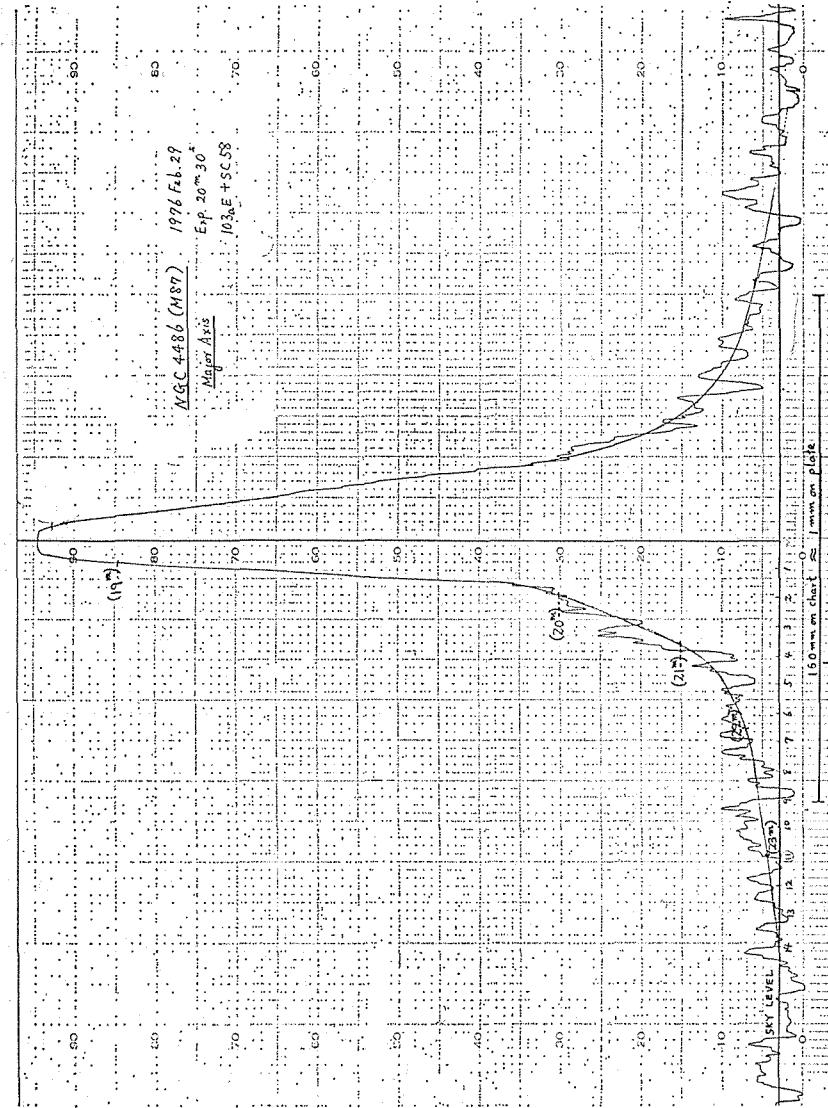

Fig. 5. The microphotometer tracing along the semi-major axis of NGC 4486 on a plate photographed by Messrs M. Yoshizawa and T. Sasaki. Numbers in parentheses shown on the mean density distribution curve denote the estimated surface brightness expressed in magnitude.

thanks are also due to Dr. B. Hidayat, the Director of Bosscha Observatory in Lembang, for his valuable comments on the design of the plate holder, and to Messrs. K. Tomita and M. Shimizu of Tokyo Astronomical Observatory, for their useful advices to the design of the mechanical system.

Some parts of this research were carried out under a research grant from the Ministry of Education, the chief of the research group being Professor T. Shimizu.

REFERENCES

- Imagawa, F. and Tsujimura, T. (1976): Technical Report No. 1, Dept. Astron., Kyoto Univ. (in Japanese)

- Kawai, S. and Imagawa, F. (1972): Reports of Meeting on Measuring Apparatus of Astronomical Plates, p. 45 (in Japanese)
- Kawai, S. and Kogure, T. (1968): Mem. Fac. Sci., Kyoto Univ., Ser. A, 33, 95.
- Markaryan, B. E.; Oganessian, E. Ya. and Arakelyan, S. N. (1965): Astrofizika, 1, 38.

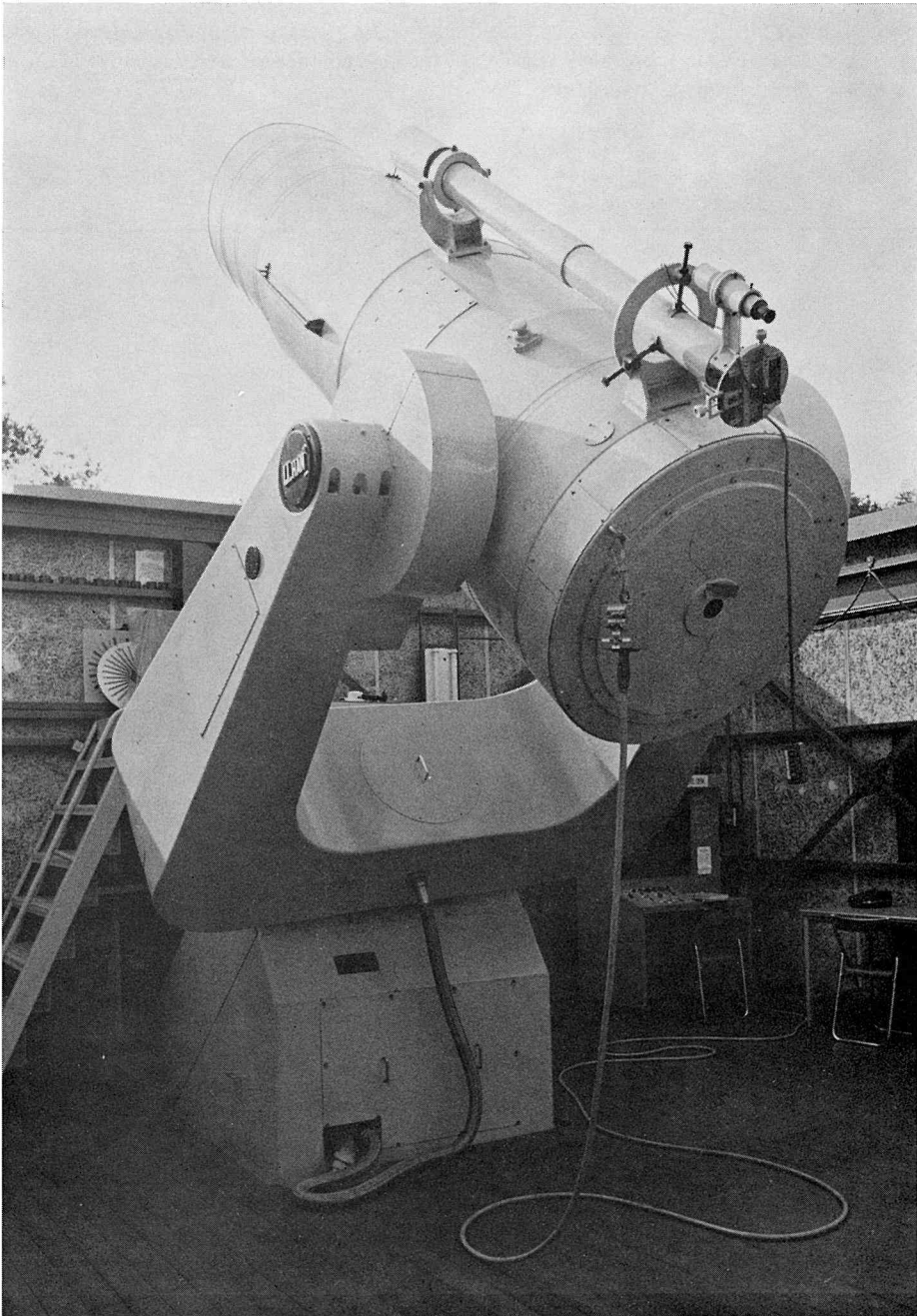

The 40/70/120 cm Schmidt telescope

APPENDIX

Our telescope is planned to be used also for a quasi-Cassegrain telescope whose effective aperture is 70 cm by removing the correcting plate and attaching a secondary mirror of aspheric of higher orders. For this purpose, a hole is made through the central part of the main mirror as seen in Figure 1. The secondary mirror aspheric of tenth order is now under construction. The surface profile of it is shown in Table A1. Figures A1 and A2 show the spot diagrams and optical system (F/10). It is a fatal defect of a quasi-Cassegrain system that extremely asymmetric aberrations appear even for slightly off-axis rays.

Table A1. Surface profile of the aspheric mirror. Radius of curvature of the reference spheric surface is 647 mm

X	$Z_2 - Z_1$
0.	0.
5.0	-0.0000
10.0	-0.0000
15.0	-0.0001
20.0	-0.0004
25.0	-0.0011
30.0	-0.0022
35.0	-0.0042
40.0	-0.0071
45.0	-0.0115
50.0	-0.0177
55.0	-0.0261
60.0	-0.0373
65.0	-0.0519
70.0	-0.0707
75.0	-0.0943
80.0	-0.1239

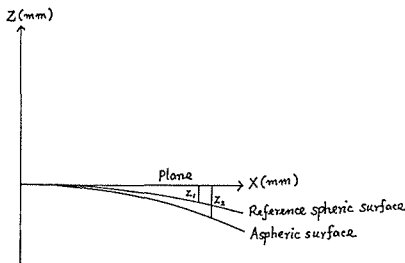

ALPHA= 0".0

ALPHA= 5".0

ALPHA= 10".0

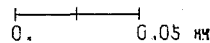
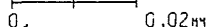
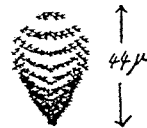
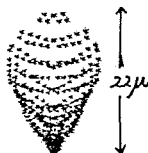

Fig. A1. Spot diagrams of the quasi-Cassegrain system. α 's are the angles of incident rays with the optical axis.

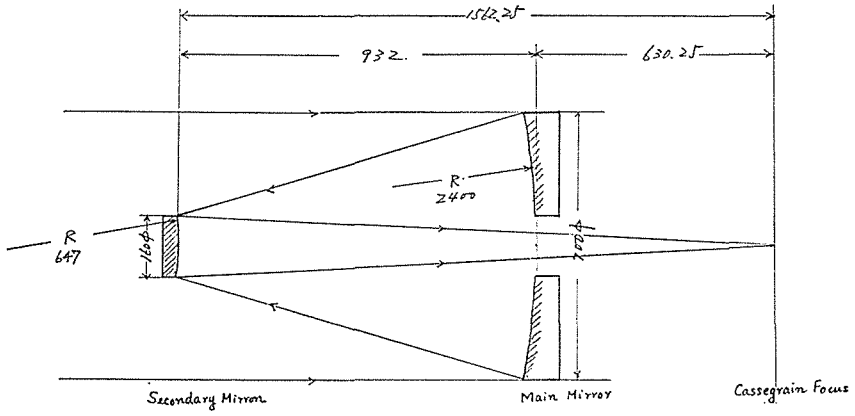

Fig. A2. Optical system of the quasi-Cassegrain telescope. Numerical values are in unit of mm.