



TITLE:

New Solar Telescope and Spectrograph Installed at the Kwasan Observatory

AUTHOR(S):

Nakai, Yoshihiro; Kubota, Jun

CITATION:

Nakai, Yoshihiro ...[et al]. New Solar Telescope and Spectrograph Installed at the Kwasan Observatory. Memoirs of the College of Science, University of Kyoto. Series A 1964, 30(3): 323-332

ISSUE DATE:

1964-03

URL:

<http://hdl.handle.net/2433/257466>

RIGHT:

NEW SOLAR TELESCOPE AND SPECTROGRAPH INSTALLED AT THE KWASAN OBSERVATORY

BY

Yoshihiro NAKAI and Jun KUBOTA

(Received January 10, 1963)

ABSTRACT

The 50 cm-aperture solar telescope with the equivalent focal length of 20 m and high-resolution spectrograph, installed at the Kwasan Observatory in 1962, are briefly described. The plate factor of the spectrograph varies from $1.1\text{\AA}/\text{mm}$ in the first order spectrum to $0.09\text{\AA}/\text{mm}$ in the fifth order at 4000\AA . The theoretical resolving power that can be predicted by diffraction theory is about 600,000 in the fifth order.

1. Introduction

As introduced by Prof. S. Miyamoto in an issue of the magazine "Sky and Telescope", the main works at the Kwasan Observatory, Kyoto, Japan, are to study the physics of celestial bodies in the solar system. The observational and theoretical investigations of the solar atmosphere are one of the most important branches in our Observatory.

About ten years ago, construction of a large-aperture solar telescope and high-resolution spectrograph was planned. After two years testing with a small coelostat of clear aperture 14 cm and a small prism spectrograph, it was decided that a large-aperture coelostat should be set as high as possible above the ground. In the spring of 1961, the new solar laboratory was built on the steep slope area in our Observatory site (Miyamoto (1)). The north-south horizontal optical tunnel was constructed over the slope and the first mirror of large-aperture coelostat is 6 m high above the ground. This situation may be rather similar to that of the Snow-telescope at the Mt. Wilson Observatory. Unfortunately, in September 1961, just before the completion of installation, a severe typhoon passed through Kyoto area, and a part of our Observatory was suffered from heavy damage, and in consequence, the onset of observation was obliged to be postponed till the spring of 1963.

We shall here report briefly the characteristics of our large-aperture coelostat and high-resolution spectrograph.

2. Solar telescope

The new solar telescope is composed of four main mountings and mirrors as shown in Fig. 1.

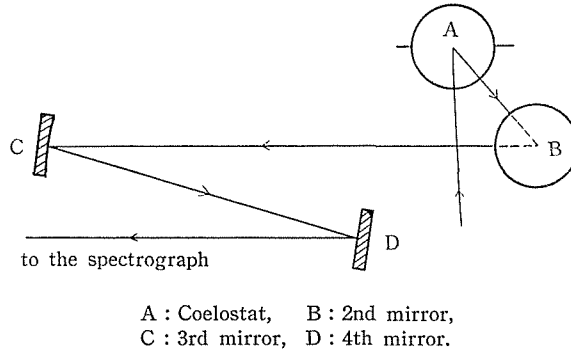

Fig. 1. Geometry of the solar telescope.

The first and second mirrors are of 70 cm in diameter and 12 cm thick. The third one is a spherical mirror of 50 cm in diameter and its focal length is 20 m. The fourth flat mirror is also of 50 cm in diameter. All these mirrors are made of optical pyrex glass. The blocks of mirrors are donated by the Osaka Industrial Research Institute, Ministry of Industry. Its low coefficient of thermal expansion is quite suitable for solar works. Figuring of the mirrors was completed by S. Kibe.

One of the characteristic features of our coelostat may be found in the main worm wheel system for diurnal motion. It consists of two pieces of wheels which can rotate around the polar axis independently. Both pieces are linked up with springs in opposite directions of rotation and this mechanism may remove off the periodic back and forth motion of the solar image due to backlash in the wheel system.

The driving mechanism for the diurnal motion of the sun was used, which was suggested by Gerrish (2) in 1948. A driving motor is set on the mounting base, and is synchronized with the Riefler pendulum clock by photoelectric devices. The rate of driving can easily be changed by increasing or decreasing the load on the pendulum. The chief disadvantage of our driving mechanism is an irregular motion due to the switching on and off. By coupling a heavy flywheel on the main shaft of the driving motor, however, such an irregularity could be smoothed out almost imperceptibly. The picture of the telescope as viewed from the south is shown on Plate I.

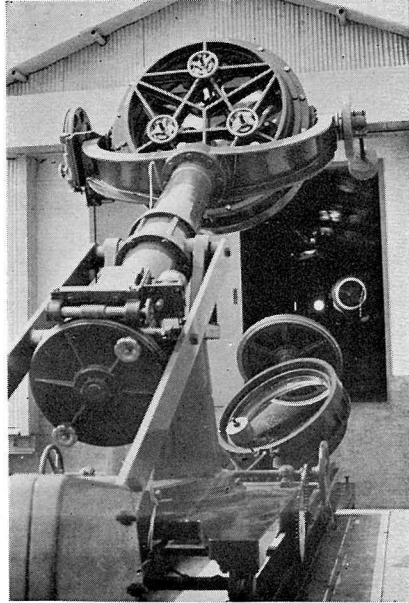

Plate I. The 70 cm coelostat and horizontal tunnel as viewed from the south.

3. Spectrograph

The dark room covering the area of 140 m², where solar grating spectrograph is installed, is the main part of our laboratory and the grating spectrograph was completed in 1961.

For the spectroscopic observations of various solar phenomena, superior characteristics are needed. Plaskett (3) has divided the technical problems in solar spectroscopy into three groups :

- (1) Profile determination,
- (2) Measurement of wavelength and line displacement,
- (3) Discrimination of spectra from different part of solar disk.

Therefore, the required characteristics of our spectrograph, satisfactorily enough to the above observations, should be as follows :

- (a) Plate factor more than 0.1 Å/mm,
- (b) Resolving power higher than 5×10^5 ,
- (c) Making the width of apparatus broadening as narrow as possible,
- (d) Symmetry of apparatus profile,
- (e) Elimination of ghost and stray light.

Besides above requirements, We wanted to use our spectrograph as a spectroheliograph and special care was taken for this mechanism.

4. Layout of dispersing system

Since our main purpose of solar research is to observe solar phenomena in greater detail, a high chromatic resolving power of spectrograph, not only for visible light but also for ultraviolet and infrared regions, is highly required. Then, it is necessary that the widths of apparatus wing due to the astigmatism of mirror system should be narrower than the natural width originating from the limited area of the dispersing element. Comparing with the size of optical system, the focal length of our mirror system, 15 m, is much longer. Then, deviation from the axial ray amounts only to $20' \sim 30'$ and the above requirement is sufficiently satisfied.

Our spectrograph may be called "vertical Littrow type", in the meaning that the light path is not found on the horizontal plane where the direction of dispersion lies. The effect of various monochromatic aberration arising from the off-axis mirror system will be minimum in the direction of dispersion, and the chromatic resolving power will be less affected.

A simple test for the resolution in the direction of the slit jaws was performed in the following way. Sticking the test pattern on the slit surface, the solar spectrum in the yellow range was photographed and shown in Plate II. Lines with an interval of 0.1 mm in the test pattern was clearly resolved. Hence, it will be expected that the fine details of the order of 1 sec of arc in the solar disc can be resolved in our spectrograph.

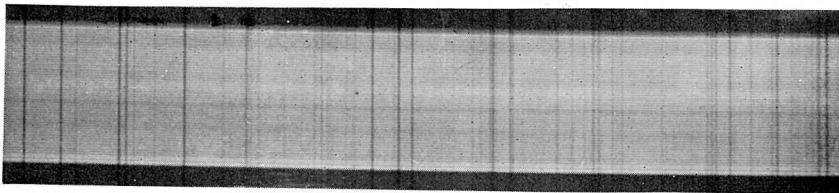
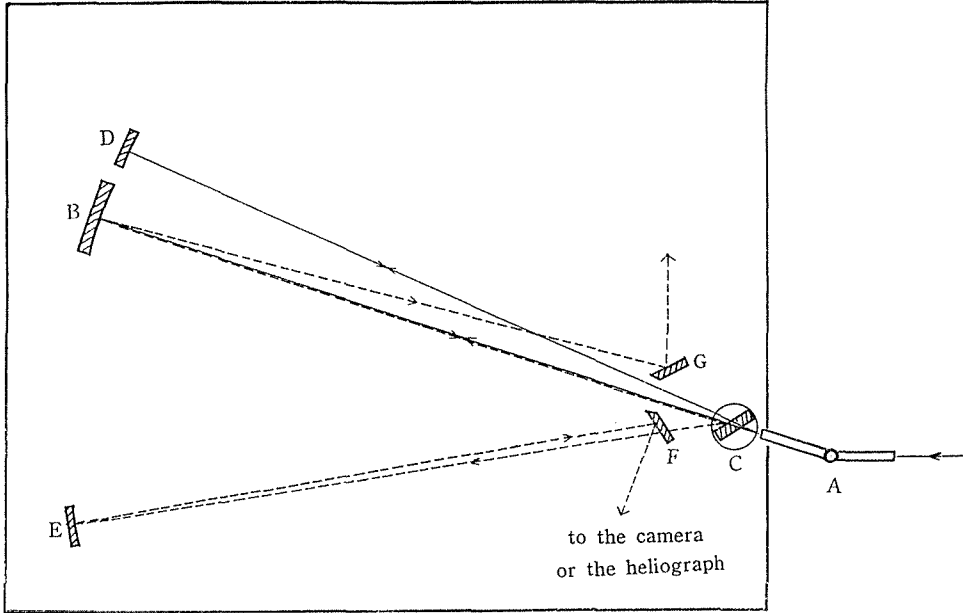

Plate II. The solar spectrum photographed with the test pattern.
(About five times enlarged)

The schematic layout of our spectrograph is shown in Fig. 2. If we use two auxiliary mirrors, the variety of observation will be increased remarkably. For example, it is possible to observe simultaneously a solar phenomenon in the two different wavelength ranges spectrographically or spectroheliographically.



- A : Monochromator for first selection.
- B : Auto-collimating mirror, 50 cm clear aperture and 15 m focal length.
- C : Grating.
- D and E : Concave mirrors for collimating and imaging, 25 cm clear aperture and 15 m focal length.
- F and G : Flat mirrors.

Fig. 2. Layout of the spectrograph.

5. Monochromator

When a grating is employed at the second or higher orders, more than ordinary precautions should be paid to eliminate the contamination of the spectrum by overlapping orders and stray light. In our spectrograph, the band width and its central wavelength range of incident ray are controlled with the small prism monochromator which was installed in front of the grating spectro-

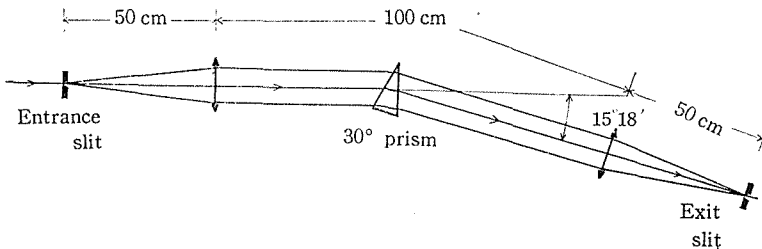

Fig. 3. Schema of the monochromator,

graph (see (4)). The schematic diagram of it is shown in Fig. 3. Based on our aim in the solar research, the monochrometer should satisfy the following conditions :

- (1) Optical elements are transparent for solar ray from ultraviolet to infrared.
- (2) Exactness of polishing.
 - a) Not to lose resolution of the objective mirror of the solar telescope.
 - b) Not to increase the stray light due to the scratch on the surface of optical elements.
- (3) Illumination of grating without any vignetting of light after passing the monochrometer.

With respect to the condition (1), many kinds of materials are available : for example, fused silica, lithium fluoride, quartz crystal and rock salt crystal. Among them, the former two are chosen because of their simple behaviours in crystal optics and property of wetproof. The 30°-prism in our monochrometer is made of fused silica manufactured by the Thermal Syndicate Co., England. Two imaging and collimating lenses are triplet apochromat, which consists of two fused silica elements and one LiF sandwiched between them (see (5)).

Theoretically, the circle of least confusion of our triplet apochromat is

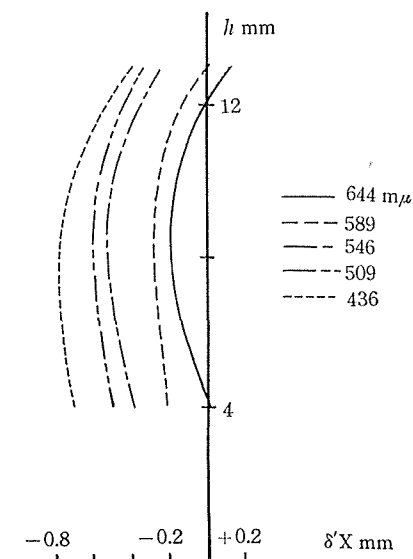

$\delta'X$: Longitudinal spherical aberration.
 h : Ray height.

Fig. 4. The aberration of the triplet apochromat,

only 0.03 mm for 5800 Å and, on the other hand, 1 sec of arc of the sun corresponds to 0.1 mm on the solar image formed by our solar telescope along the direction of entrance slit. Hence, the resolution obtained by our solar telescope can be safely transmitted to the exit slit of monochrometer. The aberration of our lenses are given in Fig. 4.

The linear dispersion of the monochrometer on the second slit is computed at seven wavelengths and given in Table 1. The width of the second slit can be changed from 0.1 mm to 3 mm, and hence the band width that is cut off by the second slit corresponds at least to 20 Å at 4000 Å.

Table 1. The linear dispersion of the monochrometer.

Wavelength	Mean linear dispersion
2967 Å	196.29 Å/mm
4046	431.21
4861	774.04
5875	1186.21
6563	1648.44
7682	2272.54
10000	3816.79
15000	

In addition, it may be pointed out that the remarkable difficulties to obtain the optical surfaces of crystalized LiF lies in the softness of the material. It seems almost impossible to finish fine surfaces. Our optical element of LiF has been polished almost satisfactorily with enormous efforts by the staffs of Chiyoda Kogaku Co., Osaka, Japan.

6. The grating

The main dispersing element used in our spectrograph is a Bausch & Lomb grating. The characteristics are shown as follows :

Ruled area	: 127 × 203 mm
Grooves/mm	: 600
Blazed angle	: 17°27'
Blazed wavelength	: 1μ (1st order)
Efficiency	: 68% (1st order)

The theoretical chromatic resolving power of a grating can be estimated by the following formula :

$$R = mn,$$

where m represents the order of the spectrum and n the number of grooves.

For our spectrograph, we have

$$\begin{aligned} R &= 121,800 \quad (1\text{st order}), \\ R &= 609,000 \quad (5\text{th order}). \end{aligned}$$

The linear dispersion, or plate factor, of a grating spectrograph is obtained by the following formula:

$$\frac{\Delta L}{\Delta \lambda} = \frac{mf}{a \cos \beta},$$

where a is the groove spacing, f the focal length of the imaging mirror, and β the angle of diffraction.

For the Littrow-type grating spectrograph, the maximum efficiency is achieved with following condition:

$$\theta = \frac{\alpha + \beta}{2} \simeq \alpha \simeq \beta,$$

where α is the angle of incidence and θ the blazed angle. With the above condition, the plate factor is computed and is given in Fig. 5.

As seen in Fig. 5, the plate factor, 0.1 \AA/mm , is realized with the third order spectrum or higher. On the other hand, the resolving power of photographic plate or film is limited by the finite size of the emulsion grain. The

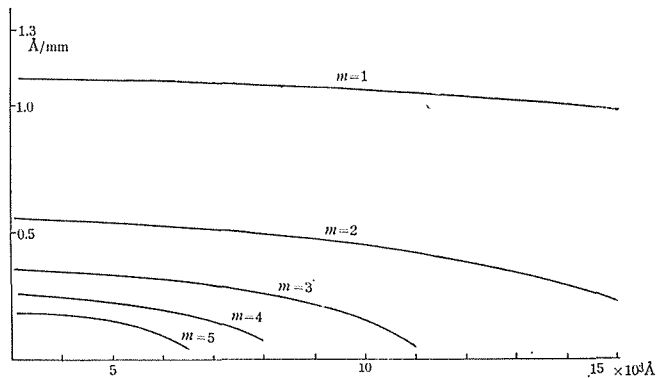

Fig. 5. The plate factor computed for the Littrow-type.

resolving power of the fifth order spectrum, $R=609,000$, corresponds to 36μ on the focal plane. Hence, the minimum resolving width of the grating spectrograph is almost comparable with the size of ordinary photographic grain. This is the reason why we choose focal length of 15 m for our imaging mirror in the spectrograph.

With respect to the supporting system of the grating a special care was paid on the simplicity and correctness of the fine adjustment of the grating. All the mechanical parts of our spectrograph were constructed with our desired accuracy in the Tsugami Precision Works Co., Tokyo, Japan (see Plate III).

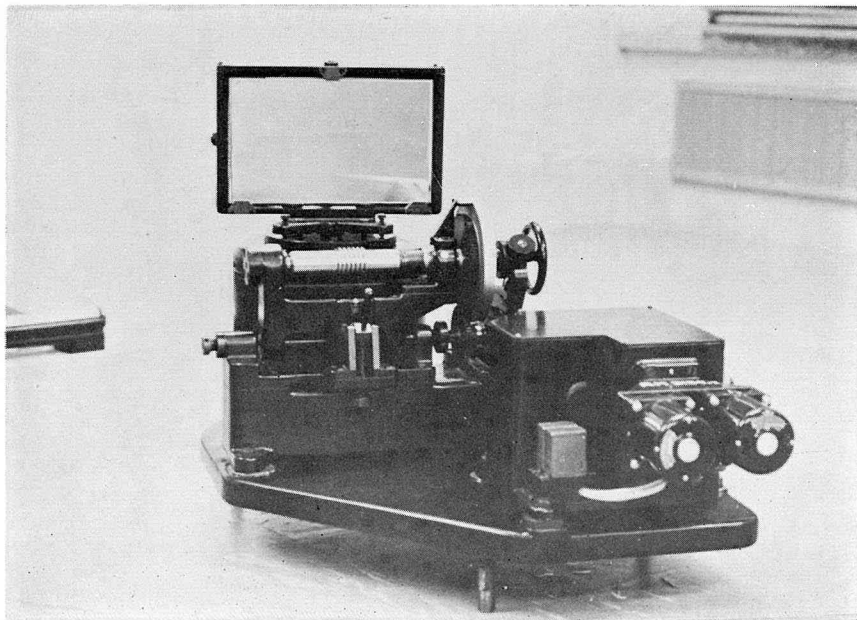

Plate III. The grating and its supporter.

At the first stage of our solar research, we are mainly interested in the spectrographic and spectroheliographic observations of the sun. However, the photoelectric scanning over the certain wavelength range may be also possible for our spectrograph. The rotational motion can be performed by two synchronous motors with the current supplied by a quartz oscillator. The rate of rotational motion can be changed from 1' to 50' per minute discretely in seven steps by gear train.

6. Spectroheliograph

Our spectrograph can be used as a spectroheliograph. The third slit in front of the heliograph is just on the focal plane of the grating spectrograph and cuts out the desired wavelength range from the spectrum. The photographic plate on the sliding rail of heliograph is driven uniformly by a motor with current supplied by the quartz oscillator. Moreover, the rate of the speed may

be changed with four steps in accordance with the slit widths of the heliograph and sensitivity of plate emulsion. The difficulties in obtaining the round image of the sun may be removed as far as we can provide uniform motion of the solar image at any necessary rate of speed on the slit of the spectrograph.

The chief disadvantage of our instrument lies in the fact that only a small part of the solar image can be scanned, because of the large solar image formed by the solar telescope and also because of the difficulties in obtaining the uniform motion over a long range. However, our spectroheliogram may have a dimension enough to cover the active region seen around the moderate spot groups.

In interpreting the spectroheliogram, it is fundamentally important to locate the wavelength range cut out from the solar spectrum. For our spectroheliograph, a simple device is provided to satisfy this requirement. This is narrow cutting just behind the slit jaw on the focal plane of our spectrograph. Inserting the photographic plate into this cutting, the solar spectrum and the image of slit jaw can be photographed simultaneously on a plate, which shows us precisely the slit position on the solar spectrum.

Acknowledgement

We express our deepest thanks to Director Prof. Shotaro Miyamoto for his encouragements and valuable advices throughout the whole period of designing and construction. We also will express our sincere thanks to Dr. Ichiro Kawaguchi who worked out basic design of the grating spectrograph. During our works, we were supported by many people directly and indirectly. Our thanks are due to them. In particular, we cannot forget the names of the staffs of the Osaka Industrial Research Institute who engaged in making whole blocks of mirror used in our laboratory, and who are responsible for arrangement to get the blocks for us with free charges. Without their aid, the solar telescope could not be brought into completion. It may be worth while to state that at the Tsugami Precision Works Co., Tokyo, all the mechanical and optical parts of our grating spectrograph were kindly tested whether their qualities are fitted to our specifications or not.

REFERENCES

1. S. Miyamoto, *Sky & Telescope* **21** (1961), No. 2.
2. W. P. Gerrish, "*Telescope & its Accessories*" (Blakiston Co., Philadelphia, 1948), p. 249.
3. H. H. Plaskett, *M. N.*, **112** (1952), 177.
4. R. R. McMath, *Ap. J.*, **123** (1956), 1.
R. R. McMath, O. C. Mohler, A. K. Pierce and L. Goldberg, *Ap. J.*, **124** (1956), 1.
5. C. H. Cartwright, *J. Opt. Soc. America* **29** (1939), 350.