



TITLE:

Electron Density Measurement by Microwave Interferometer

AUTHOR(S):

Tanaka, Shigetoshi

CITATION:

Tanaka, Shigetoshi. Electron Density Measurement by Microwave Interferometer.
Memoirs of the College of Science, University of Kyoto. Series A 1961, 29(3): 353-360

ISSUE DATE:

1961-09

URL:

<http://hdl.handle.net/2433/257440>

RIGHT:

ELECTRON DENSITY MEASUREMENT BY MICROWAVE INTERFEROMETER

BY

Shigetoshi TANAKA

(Received March 17, 1961)

ABSTRACT

The relative phase shift of the electromagnetic wave propagating through a uniform plasma in a waveguide section was derived. By a microwave interferometer which has a waveguide section filled with a stationary gaseous discharge plasma in the test path, the relative phase shift and hence the electron density was measured at 10 GC/S as a function of tube current. At the same time, the electron density was measured by using Langmuir probe. The electron density measured by Langmuir probe was always several times larger than that by microwave method. The difference can be explained, assuming a spatial distribution of the electron density in the discharge plasma.

1. Introduction

Microwave techniques have been used for the study of electron loss process in the afterglow of gaseous discharge (1, 2, 3, 4). The so-called microwave diagnostics of plasma has prospered recently in connection with the problems of the controlled thermonuclear fusion (5, 6). There are three methods to measure electron density and collision frequency of electron in plasma, that is, cavity method (7), reflection method (8) and propagation method. In the propagation method it is common to use the microwave interferometer in which the plasma is either confined in a waveguide section or in a free space (9, 10).

In this paper, we have derived a relation between the electron density and the relative phase shift, as well as that between the collision frequency and the attenuation, when the wave propagates in a waveguide section filled with uniform plasma. Using these relations, we have measured the electron density as a function of tube current. However, the measured values were different from those measured by Langmuir probe. The difference is naturally expected, since by Langmuir probe method the electron density is locally measured, whereas in microwave method the whole plasma space is effective.

Although we could not derive a relation between both values, the difference was explained by considering a spatial electron density distribution in plasma.

2. Theory of experiment

The wave propagating in a guide filled with uniform isotropic plasma is considered. If the cross section of the guide is uniform, the electric vector propagating along the z -axis, which is the guide axis, is given by (11):

$$\mathbf{E}(x, y) \exp(-j\omega t + jhz),$$

with

$$h^2 = k^2 - k_c^2 = k_0^2 K - k_c^2,$$

where $K = K_{\text{re}} + jK_{\text{im}}$ is the specific inductive capacity, $k_c = 2\pi/\lambda_c$ and λ_c is the cutoff wavelength. h can be represented in terms of the phase constant β_p and the attenuation constant α_p as:

$$h = \beta_p + j\alpha_p \quad (\beta_p > 0, \alpha_p \geq 0), \quad (1)$$

where

$$\beta_p = \frac{k_0}{\sqrt{2}} \left\{ K_{\text{re}} - \left(\frac{k_c}{k_0} \right)^2 \right\}^{1/2} \left[1 + \left\{ 1 + \left(\frac{K_{\text{im}}}{K_{\text{re}} - (k_c/k_0)^2} \right)^2 \right\}^{1/2} \right]^{1/2}, \quad (2)$$

and

$$\alpha_p = \frac{k_0}{\sqrt{2}} \left\{ K_{\text{re}} - \left(\frac{k_c}{k_0} \right)^2 \right\}^{1/2} \left[-1 + \left\{ 1 + \left(\frac{K_{\text{im}}}{K_{\text{re}} - (k_c/k_0)^2} \right)^2 \right\}^{1/2} \right]^{1/2}. \quad (3)$$

Thus, the relative phase shift $\Delta\theta_g$ and the attenuation α_g per λ_g are given by:

$$\Delta\theta_g = 2\pi \left\{ 1 - \frac{1}{\sqrt{2}} \frac{\lambda_g}{\lambda} \left\{ \left(\frac{\lambda}{\lambda_g} \right)^2 - \frac{\eta}{1+\beta^2} \right\}^{1/2} \left[1 + \left\{ 1 + \left(\frac{\eta\beta/(1+\beta^2)}{(\lambda/\lambda_g)^2 - \eta/(1+\beta^2)} \right)^2 \right\}^{1/2} \right]^{1/2} \right\}, \quad (4)$$

and

$$\alpha_g = \frac{2\pi}{\sqrt{2}} \frac{\lambda_g}{\lambda} \left\{ \left(\frac{\lambda}{\lambda_g} \right)^2 - \frac{\eta}{1+\beta^2} \right\}^{1/2} \left[-1 + \left\{ 1 + \left(\frac{\eta\beta/(1+\beta^2)}{(\lambda/\lambda_g)^2 - \eta/(1+\beta^2)} \right)^2 \right\}^{1/2} \right]^{1/2}, \quad (5)$$

where $\eta = (\omega_p/\omega)^2$ and $\beta = \nu_c/\omega$, ω_p is the plasma frequency, ν_c the collision frequency and λ_g the air-filled guide wavelength. (4) and (5) reduce to the free space propagation with $\lambda_c \rightarrow \infty$, hence $\lambda_g \rightarrow \lambda$.

For $\beta^2 \ll 1$, (4) becomes:

$$\Delta\theta_g = 2\pi \left[1 - \left\{ 1 - (\lambda_g/\lambda)^2 \eta \right\}^{1/2} \right] \quad (\text{radian}/\lambda_g). \quad (6)$$

Moreover, if $(\lambda_g/\lambda)^2 \eta \ll 1$, (6) can be approximated by:

$$\Delta\theta_g = \pi(\lambda_g/\lambda)^2 \eta. \quad (7)$$

For the free space, the critical condition for wave propagation is given by $\eta=1$. For the waveguide, the condition becomes:

$$k_0^2 K_{\text{re}} - k_c^2 = 0 \quad \text{or} \quad \eta = (\lambda/\lambda_g)^2, \quad (8)$$

which is satisfied for the smaller electron density η , because of $\lambda < \lambda_g$. In addition, if we set the signal frequency and the dimensions of waveguide appropriately in such a way that λ/λ_g takes an arbitrary value smaller than unity, we can principally determine the electron density from the critical condition.

In Fig. 1 are plotted the relative phase shifts $\Delta\theta_g$, assuming the TE_{10} -mode wave propagating in an X-band waveguide, and $\Delta\theta$ for the free space as functions of η . It is evident that in Fig. 1 $\Delta\theta_g$ is larger than $\Delta\theta$, so we can measure the lower electron density by the waveguide propagation than by the free space one, for the same minimum detectable phase shift.

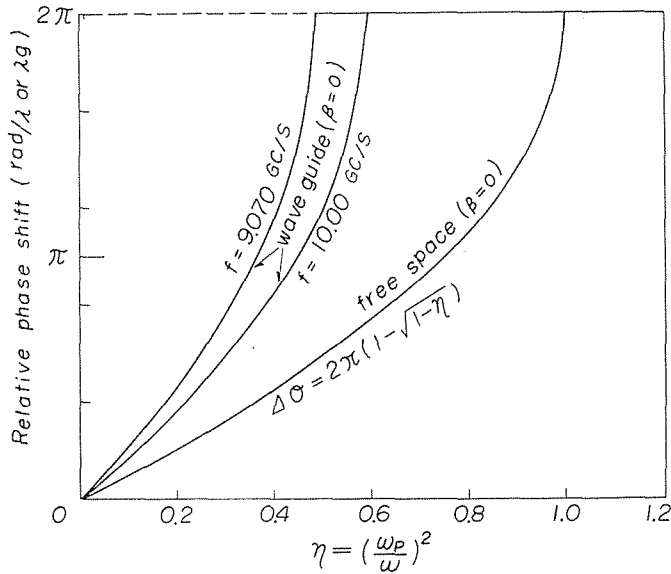

Fig. 1. Relative phase shifts in uniform plasma.

3. Experimental equipment

The block diagram of the microwave interferometer is given in Fig. 2. An experimental discharge tube is inserted in a specially designed square waveguide section, a side length of which is equal to the larger side length of the standard guides, which are connected on both sides through tapered ones. The experimental discharge tube is shown in Fig. 3. The holes of the guide wall, through which the discharge tube is inserted, is desired to be as small as possible, so the tube is made slender in two parts. The tube is also equipped with a Langmuir probe, consisting of wolfgang wire (0.70 mm in diameter and 0.34 mm in length). The filled gases and gas pressures of each tube are given in Table 1.

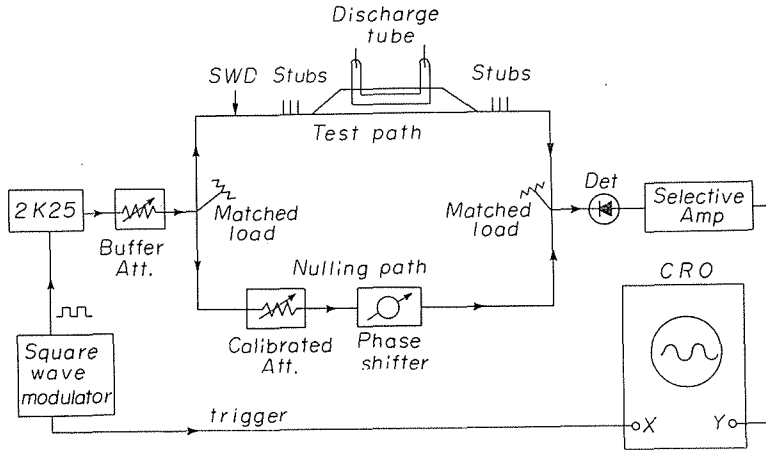

Fig. 2. Block diagram of microwave interferometer.

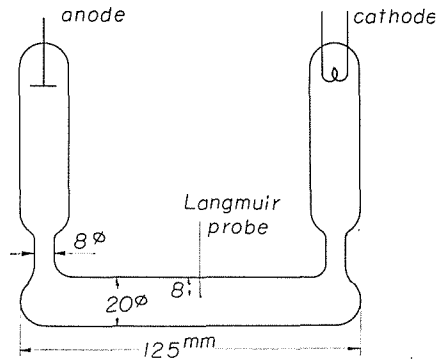

Fig. 3. Discharge tube.

Table 1.

Tube No.	Filled gas and pressure	N_1 (cm^{-3})	N_2 (cm^{-3})	N_2/N_1	T_e ($^{\circ}\text{K}$)
1	Ar (1 mmHg) + Hg	3.0×10^{11}	—	—	—
2	Ar (0.5) + Hg	2.1×10^{11}	5.4×10^{11}	2.6	2.7×10^4
3	He (0.93)	$8.0 \sim 12 \times 10^{10}$	3.6×10^{11}	3.0~4.5	5.2×10^4
4	He (0.27)	$2.0 \sim 3.3 \times 10^{10}$	1.0×10^{11}	3~5	6.8×10^4

By adjusting the attenuator and the phase shifter in the nulling path, we measure the microwave attenuation and the phase shift in plasma, then we can calculate η and β , and hence the electron density and the collision frequency by (4) and (5). Further we measure the voltage-current characteristics of Langmuir probe, and calculate the electron density and temperature, for comparison.

4. Experimental results

In calculating the electron density from the phase shift, the attenuation terms are neglected and (6) is used, since the gas pressure is less than one mm Hg in our experiment. Next, in measuring the phase shift, the effect due to the impedance mismatching caused by plasma is estimated as follows. When there is no plasma, the phase shift due to the mismatching in the test path is measured at various VSWR's by adjusting the stubs. The shift due to the mismatching of the plasma-filled guide is estimated from VSWR at various tube currents.

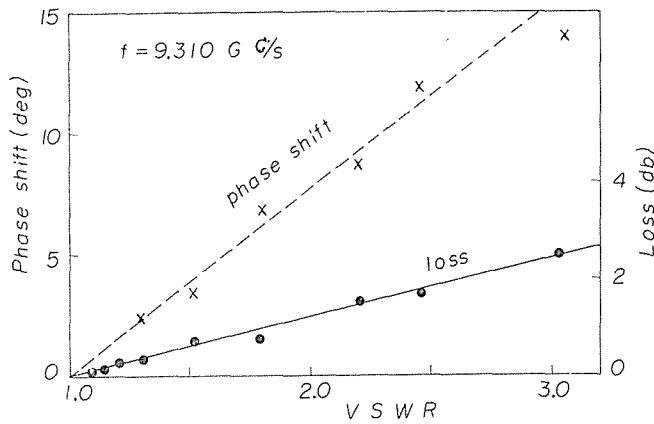

Fig. 4. Phase shift and attenuation due to mismatching in test path ($f=9.310$ GC/S).

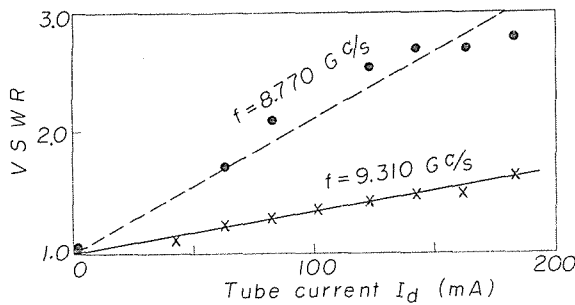

Fig. 5. VSWR versus tube current (tube No. 3).

In Fig. 4 are plotted the phase shift and the attenuation due to the mismatching at the frequency $f=9.310$ GC/S. The measured VSWR is plotted against the tube current in Fig. 5. In our measurements, however, the phase shifts due to

mismatching are considerably small in comparison with those in plasma, so they have been neglected in measurements of the phase shifts in plasma. In Fig. 6 are plotted the electron densities *versus* the tube current. The values by Langmuir probe are several times larger than those by microwave method. We shall discuss it later. In Table 1 are given the electron density N_1 measured by microwave method, the electron density N_2 measured by Langmuir probe, the ratio N_2/N_1 and the electron temperature T_e at the tube current $I_d=200$ mA for each discharge tube.

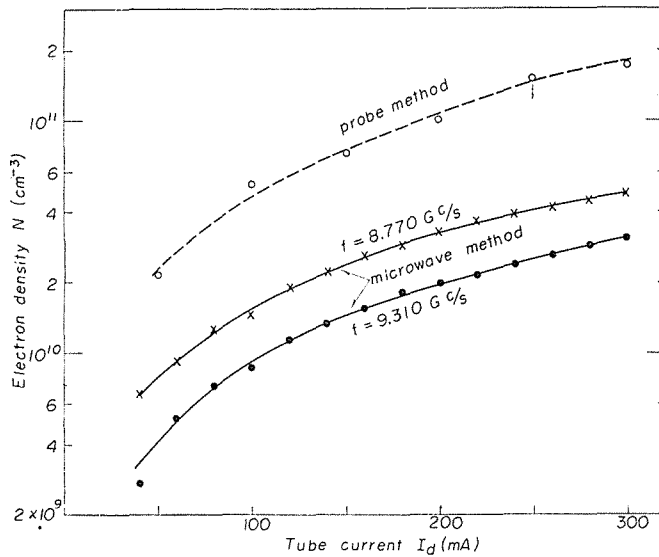

Fig. 6. Electron density *versus* tube current (tube No. 4).

In measurement of the microwave attenuation due to plasma, the apparent loss α_0 in test path measured by adjusting the attenuator in nulling path can be given by the sum :

$$\alpha_0 = \alpha_1 + \alpha_2 + \alpha_3,$$

where α_1 is the loss in the plasma, α_2 is the loss due to the reflection by mismatching, and α_3 is the leakage loss through the holes of guide wall. α_2 can be estimated by measuring VSWR, but the leakage can not. The apparent loss α_0 in test path as a function of tube current is plotted in Fig. 7, though the collision frequency of electron cannot be calculated directly from this curve.

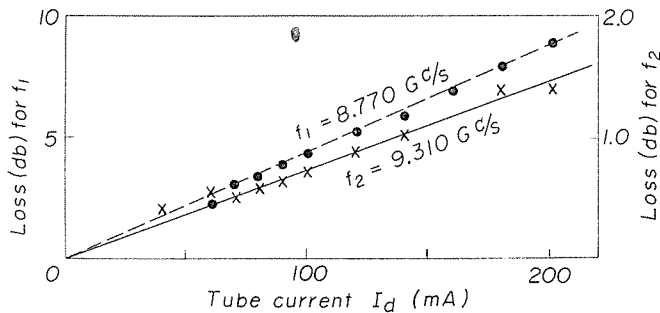

Fig. 7. Apparent loss versus tube current (tube No. 3)

5. Discussion

As stated above, the electron density measured by Langmuir probe was always several times larger than that measured by microwave method. The reason for the difference between these two seems to be as follows. In Langmuir probe method, the electron density at the point where the probe is located is measured, while in microwave method, the electron density somehow averaged over the plasma-filled guide space is effective for the total relative phase shift. For example, if the density distribution is three-dimensionally sinusoidal in space, the maximum density N_m is $(\pi/2)^3 \approx 3.9$ times the averaged density N . On the other hand, if the plasma in a guide is uniform along the axis, but the density distribution is sinusoidal in the cross section, $N_m/N = (\pi/2)^2 \approx 2.5$. Therefore, the ratio $N_2/N_1 = 3 \sim 4$ of the present experiments is to be expected, since Langmuir probe was inserted near the centre of the plasma column.

In conclusion, the microwave interferometer seems to provide a convenient and easy method for measuring the average electron density in gaseous discharge plasmas.

Acknowledgments

The author wishes to express his sincere thanks to Prof. I. Takahashi for his guidance and to Messrs. R. Itadani and H. Kubo for help in preparing the discharge tubes and the apparatus.

REFERENCES

1. L. GOLDSTEIN: *Advances in Electronics and Electron Physics*, edited by L. MARTON (Academic Press, Inc., N. Y., 1955), Vol. 7. p. 399.
2. M. A. BIONDI and S. C. BROWN: *Phys. Rev.* **75** (1949), 1700.
3. L. J. VARMERIN: *Phys. Rev.* **84** (1951), 563.
4. J. M. ANDERSON and L. GOLDSTEIN: *Phys. Rev.* **100** (1955), 1037.
5. S. C. BROWN: 2nd International Conf. on the Peaceful Uses of Atomic Energy (1958) P/385.

6. C. B. WHARTON: UCRL-4836 (Rev.) (1957).
7. S. C. BROWN and D. J. ROSE: J. Appl. Phys. **23** (1952), 711, 719.
8. L. GOLDSTEIN and T. SEKIGUCHI: Phys. Rev. **109** (1958), 625.
9. R. F. WHITMER: Phys. Rev. **104** (1956), 572.
10. L. GOLDSTEIN, *et al.*: Elec. Commun. **29** (1952), 243.
11. J. C. SLATER: *Microwave Electronics* (D. Van Nostrand Co., New York, 1950).