



TITLE:

Studies on the Ion Source placed in a Magnetic Field

AUTHOR(S):

Sakisaka, M.; Miyashiro, S.; Uemura, T.; Yasumi, S.

CITATION:

Sakisaka, M. ...[et al]. Studies on the Ion Source placed in a Magnetic Field. Memoirs of the College of Science, University of Kyoto. Series A 1950, 26(1-2): 143-150

ISSUE DATE:

1950-10-31

URL:

<http://hdl.handle.net/2433/257353>

RIGHT:

Studies on the Ion Source placed in a Magnetic Field

By

M. Sakisaka, S. Miyashiro, Y. Uemura and S. Yasumi

(Received July 31, 1950)

ABSTRACT

A new type of ion source without hot cathode is constructed, which is little consumable in electric power but gives comparatively intense ion current. The discharge is produced in a small cylindrical space under coaxial magnetic field. Between the iron cathodes which constitute themselves a pair of magnetic pole pieces an anode of doughnut shape is settled. The ions are generated by the agitative movement of electrons in the electric and magnetic fields and then introduced into the higher vacuum side through a canal bored in one of the cathodes.

In the case of hydrogen gas, it is operated adequately by the discharging voltage of D. C. 1000~2000 volts under the magnetic field of 200~500 gauss at the vacuum pressure of 8×10^{-4} ~ 3×10^{-3} mmHg, and the extracted ion current is 20~300 μ A. The output ion current is easily controlled by the adjustment of discharging voltage, magnetic field or vacuum pressure. The mass analysis shows that more than 60 per cent of total ions are protons.

The comparison between the theoretical and experimental results for protons passing through the canal is discussed and the most effective size of canal is deduced.

A gas leak apparatus to adjust the pressure range for proper operation is also devised.

1. Introduction

For long years we have hoped some improvements to the ion source of Rutherford-Oliphant type (1) which has been used as a proton source for atomic disintegrations in our laboratory.

Recently, ion sources produced in magnetic field have been studied by many workers (2). Almost all of them are "low voltage arc type" with hot cathode. The pressure of the discharge tubes of this type lies generally between 5×10^{-3} and 5×10^{-2} mmHg. Though they have many advantages in the usages, the life of the hot filament is often the defect of the tubes of this type, because, when strong current of ions is necessary and heavy arc discharge is made, the filament is

liable to be damaged by the bombardment of ions. Therefore it is desirable to construct a low voltage ion source without hot cathode operating at a pressure as low as possible.

We know, in some of the discharge tubes (3) which have particular arrangement of electrodes combined with magnetic field, the probability of ionization is increased and the discharge can go on in high vacuum even they are made without hot filament. Philips vacuum manometer (4) is one of these types in which electrons move agitatingly between a ring anode and two disc cathodes settled at its opposite sides. A study, both theoretical and experimental, of the discharging mechanism of this tube gives us a suggestion to modify it for constructing an ion source for the purpose.

After two years' investigations a tube is obtained which is promising to be used. It is easily controllable and durable in life and moreover it can be operated with small consumption of electric power.

2. Apparatus

The construction is shown in Fig. 1. A is the brass anode of doughnut shape having a hole of 1 cm in diameter and 1 cm in length. B and C are iron cathodes which constitute themselves at once magnetic pole pieces. A canal, whose size will be later discussed, is bored in the lower pole. The ions in this small cylindrical space are introduced through the canal to higher vacuum side and collected by the Faraday cylinder F. E is a retarding plate to suppress the secondary electrons produced from F when it is bombarded by ions. G is a Philips vacuum gauge. Gas is inletted through L from a slow leak apparatus, the details of which will be described in the following section. Coil M produces magnetic field mainly at the discharging place D.

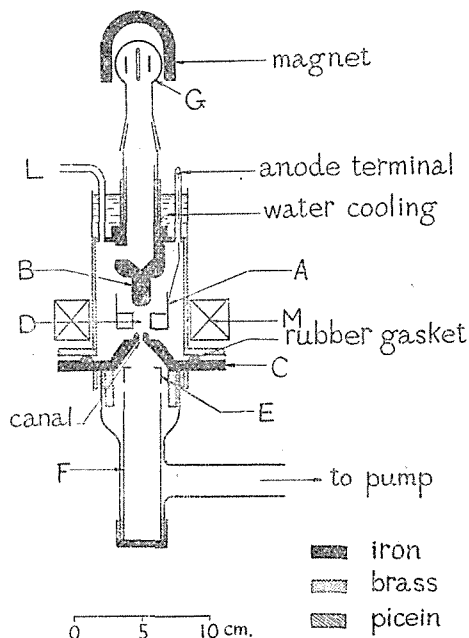

Fig. 1. Construction.

Fig. 2 shows the system of the electric power supply, which is a simple rectifying circuit. The signs in Figs. 1 and 2 are correspondently indicated. The upper part of Fig. 2 is the high voltage generator of 500~2500 volts and the lower one is that for magnetic field. R is a high wattage resistance of 3~10 K.Ω for the protection of sudden break down of the discharge.

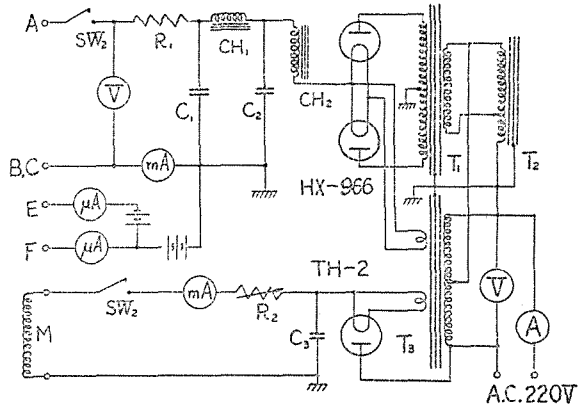

Fig. 2. Electric power supply.

3. Operation and measurements

Raising the anode potential of ion source to about 500 volts and the magnetic field to about 200 gauss, the discharge is produced when the pressure is about 1×10^{-3} mmHg. The relations between the discharging current and the anode potential is shown in Fig. 3 at various pressures. Fig. 4 gives the output ion current from the canal of 1 mm in diameter and 5 mm in length. Generally, the more the ion current is obtained, if the more the anode potential, the magnetic field and the vaccum pressure be raised. But when the pressure becomes over 3×10^{-3} mmHg, the glow discharge in the ion source transfers to an arc discharge, resulting in the drop of anode potential to about 400 volts, and the yield of output ions suddenly decreases. On the other hand, when the pressure becomes as low as about 6×10^{-4} mm-Hg no more ions become to be extracted. Under these

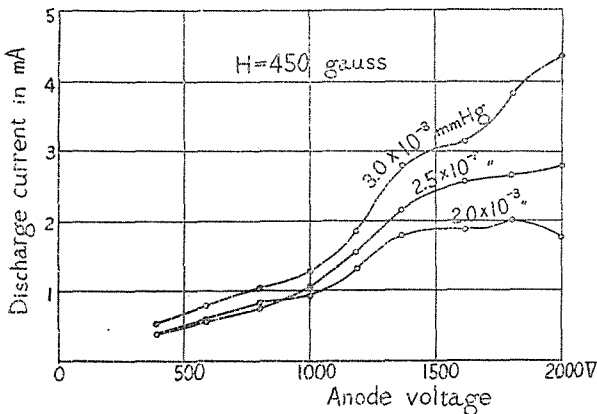

Fig. 3. Discharging current.

On the other hand, when the pressure becomes as low as about 6×10^{-4} mm-Hg no more ions become to be extracted. Under these

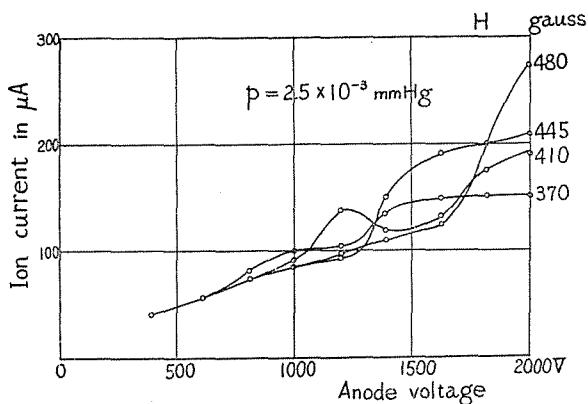

Fig. 4. Output ion current at various magnetic fields.

can reach the anode without necessary production of ions by collision to continue the discharge. This causes the instability of ion current by the slight variation of anode potential. But if the magnetic field be modulated by superposition of alternative current, the stability of the ion current is continued and the sharp peak in the diagram is flattened as shown in Fig. 5. The maximum electric powers consumed are about 20 watts for the discharge and 70 watts for the magnetic field respectively.

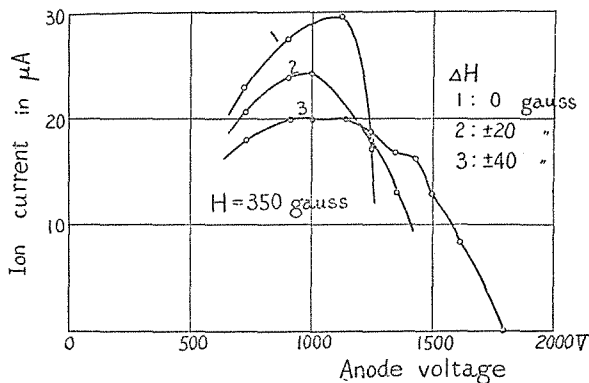

Fig. 5. Stabilization of ion current.

4. Analysis of hydrogen ions

Ions from the source were analysed by a simple mass spectrometer. In the case of hydrogen, it was found that about half of the total ions were protons at the beginning of the experiment. While, after long operation, the abundance of protons increased to 60 per cent or more. Other kinds of ions were scarcely detected in our experiment.

5. Discussion on the canal size

For atomic disintegration experiment, as much amount of ion cur-

conditions the yield sharply gets down if the anode potential is inadequately raised. The reason is probably that, because of the inadequately strong electric field in comparison with magnetic field, the electrons emitted from cathodes by the bombardment of ions

rent as possible is requested. For this purpose it is naturally desirable to have wide canal. Since, however, the evacuation through it prevents the stable operation of the ion source at necessary vacuum pressure, there must be some restrictions to the canal conductance for proper working of vacuum system. Moreover, since a fraction of ions passing through the canal will be lost by absorption, recombination or scattering, depending upon the canal size, they make themselves the second limitations for the latter.

According to Brown (5), gaseous conductance of a pipe of length l and diameter a is given by

$$G = \left(\frac{\pi}{2}\right)^{\frac{3}{2}} \frac{a^3}{l + \frac{\pi}{2} \left(\frac{2}{f} - 1\right) a} \left(\frac{2}{f} - 1\right) \sqrt{\frac{RT}{\mu}}, \quad (1)$$

where f is a constant concerning pipe wall, which is experimentally determined by Brown as 0.77. R , T and μ are the universal gas constant, absolute temperature and molecular weight of the gas respectively. If we assume that the pressure p_1 of the ion source is far larger than p_2 of higher vacuum side, the quantity Q of gas passing through the pipe per second is given by

$$Q = Gp_1. \quad (2)$$

Now, when the ions are running, they exert repulsive force to each other and produce, on the other hand, magnetic force which results in the attraction among themselves (6). If the cylindrical beam of ions of radius ρ_0 consists of the ions of the same mass m and charge e , a unit charge on its periphery receives these forces simultaneously from every one of ions and the beam is liable to diverge itself. The aspect is shown in Fig. 6. Calculation of these forces leads to the following formula, which shows that the ion beam of radius ρ_0 diverges to that of radius ρ after running the distance S :

$$\sqrt{\frac{ie(1-\beta^2)}{\rho_0 mv}} t = \sqrt{\frac{ie(1-\beta^2)S}{\rho_0 mv}} \frac{S}{v} = \int e^{y^2} dy, \quad (3)$$

where i and v are the total ion current and the velocity of ions, and y and β are equal to $\log(\rho/\rho_0)$ and v/c , i. e. the ratio of v and the velocity of the light, respectively.

If it is assumed that protons pass through a cylindrical canal of

constant conductance and that when they collide the canal wall, they are simply absorbed without any production of secondary ions or any reflexion, the amount of protons at the outlet varies simply with the radius and length of the canal.

Furthermore, if the ion current of constant density per unit area comes to the inlet of the canal, the amount of the ions is proportional to its area, i. e. πa^2 . The beam would diverge, if no canal wall were there, to the radius a' after running the distance l from the inlet, but the wall absorbs divergent ions, which are indicated by the shadowed portion in Fig. 6. Thus at the outlet only the fraction a^2/a'^2 of the total amount of the inlet ions will be obtained. In this case we can replace S , ρ_0 and ρ in Eq. (3) by l , a and a' . Combining Eqs. (1),

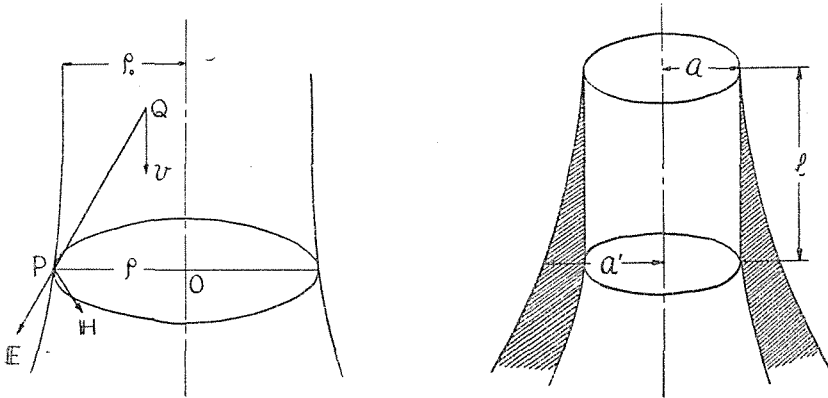

Fig. 6. Divergence and absorption of ion beam.

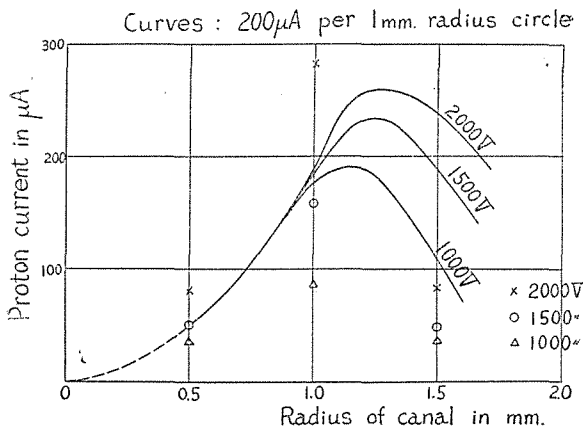

Fig. 7. Output proton current from various canals.

(2) with this fraction, the output ion current in question can be calculated. For example, the output proton currents of various energies obtained through the canal of conductance 440 cc/sec in hydrogen gas, are shown in Fig. 7. In this case the current density is taken as

200 μA per circle of 1 mm radius at the inlet of the canal.

For experimental verifications, we used the following three cylindrical canals having the same value of the above-mentioned conductance. Some of the experimental results are plotted also in Fig. 7. In this experiment there remain uncertainties concerning the uniformity of incident current density, the abundance of protons, their energy distributions and others. However, according to our simple assumptions, we find that the behaviours of experimental results and the theoretical calculations are well agreeable with each other. Moreover, the propriety of Fig. 7 is more emphasized, if we take the mean energy of ions lower than the discharging voltage of the ion source. Thus the most effective size of the canal suitable for about 1500 volts energy protons is determined to be nearly equal to 1.2 mm in radius and 10 mm in length.

TABLE 1. Size of three canals.

No.	l (length in mm.)	a (radius in mm.)
1	0	0.5
2	5.2	1.0
3	23	1.5

6. Gas leak

It is also important to know the best condition of the pressure of the ion source to be operated properly. After a series of experiments, it was found that the method of gas inlet is most influential upon it and that it is adequate to apply a simple apparatus in which gas leaks through a porcelain of small and constant conductance (g) from the gas reservoir of large volume (V). After time t the pressure p in this reservoir decreases exponentially as

$$p = p_0 \exp(-gt/V), \quad (4)$$

where p_0 is the initial pressure. The leaking quantity converted at p_0 is derived as

$$q = g \exp(-gt/V). \quad (5)$$

The experimental results are given in Fig. 8. Thus the adequate operating range of the ion source is found to lie between 8×10^{-4}

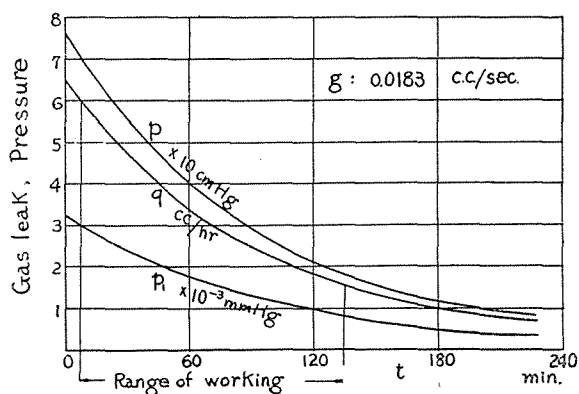

Fig. 8. Gas leak.

and $3 \times 10^{-3} \text{ mmHg}$. The best condition to produce as intense ions as possible is at the neighbourhood of $3 \times 10^{-3} \text{ mmHg}$. In this case the leak quantity of hydrogen gas is found to be about 6 cc/hr which is appropriate for the evacuating speed of ordinary diffusion pump.

7. Conclusion

By modifying the principle and mechanism of Philips vacuum gauge tube, it has been found that an ion source suitable for nuclear experiment may be promisingly constructed. Necessary improvements concerning magnetic field, electric and magnetic focusing and the device for intensifying current, are now being studied.

In conclusion the writers wish to express their cordial thanks to Profs. B. Arakatsu and K. Kimura for their valuable suggestions and to other members in our laboratory for their helps. The writers also acknowledge their indebtedness to the support of the Scientific Research Expenditure of the Ministry of Education.

REFERENCES

1. M. L. Oliphant and Lord Rutherford, Proc. Roy. Soc. London, **141** (1933), 259.
A. Bouwers, F. A. Heyn and A. Kuntke, Physica, **4** (1937), 153.
2. R. B. Satlow, R. S. I., **20** (1949), 558.
A. T. Finkelstein, R. S. I., **11** (1940), 94.
C. Bailey, R. S. I., **20** (1949), 189.
F. M. Penning, Physica, **4** (1937), 1190.
3. F. M. Penning, Physica, **3** (1936), 876.
4. C. Hayashi and others, R. S. I., **20** (1949), 524.
F. M. Penning, Physica, **3** (1936), 876.
E. C. Evans and K. E. Burmaster, Proc. I. R. E., **38** (1950), 651.
5. G. P. Brown, J. Appl. Phys., **17** (1946), 804.
6. E. E. Watson, Phil. Mag., **3** (1939), 849.
M. Knoll, Ann. d. Phys., **12** (1932), 604.
F. D. Fowler, Phys. Rev., **46** (1935), 1075.
L. P. Smith, J. Appl. Phys., **11** (1940), 220.