



TITLE:

Research and Developments for Enhancing Seismic Performance of Wooden Dwelling Houses in Recent Japan

AUTHOR(S):

Komatsu, Kohei

CITATION:

Komatsu, Kohei. Research and Developments for Enhancing Seismic Performance of Wooden Dwelling Houses in Recent Japan. 73rd Symposium on Sustainable Humanosphere - RISH-LAPAN-LIPI International Symposium, Science for Sustainable Humanosphere, International Collaborative Programs in Indonesia 2007

ISSUE DATE:

2007-07-25

URL:

<http://hdl.handle.net/2433/255482>

RIGHT:

発行元の許可を得て掲載しています。

73rd Symposium on Sustainable Humanosphere - RISH-LAPAN-LIPI International Symposium

Science for Sustainable Humanosphere

International Collaborative Programs in Indonesia, LAPAN, Bandung, Indonesia, July 25, 2007

Research and Developments for Enhancing Seismic Performance of Wooden Dwelling Houses in Recent Japan

by

Kohei Komatsu

Professor, Laboratory of Structural Function

Research Institute for Sustainable Humanosphere, Kyoto University

Gokasyou, Uji, Kyoto 611-0011, JAPAN

Phone: +81-774-38-3674 Fax : +81-774-38-3678

E-mail: kkomatsu@rish.kyoto-u.ac.jp

1. Major Earthquakes in Past 100 Years in Japan

Table 1 shows earthquake records in past 100 years in Japan, which gave devastating damages on both people and wooden dwelling houses. From this table, it can be recognized that during past 100 years, there were so many server earthquakes in our land and on each times a lot of wooden dwelling houses were destroyed thus so many peoples were killed by these earthquakes.

On the other hand, strategies for resisting earthquake or damage preventing technology have been investigated every time severe earthquake attacked wooden residential houses. The first important response to resist against earthquake strike was to establish the Building Standard Law in 1950. In this occasion, so-called “shear wall resistance factor: SWRF” was first introduced to calculate simply how much is the total resisting ability of wooden residential house against seismic force. Figure 1 explains simply how seismic force can be resisted by a group of shear walls.

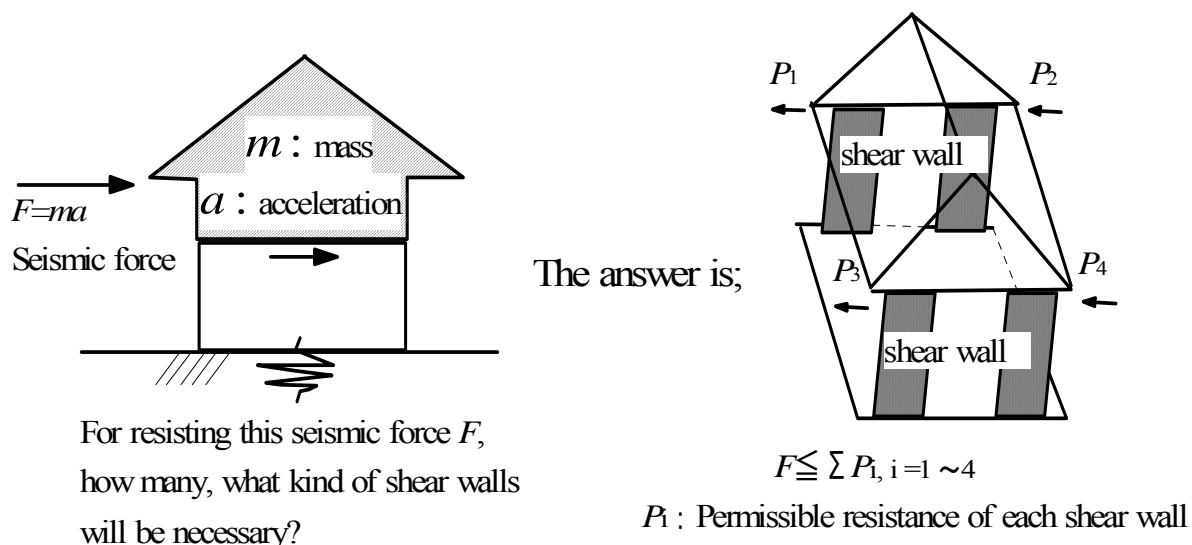

Fig.1 Schematic explanation for checking out the necessary shear wall quantity.

Table 1 Earthquake Damages on Peoples as well as Wooden Dwelling Houses in Past 100 years.			
Christian Era	Domestic Era	Earthquake & Damages	Proposals for Enhancing Earthquake Resistance of Wooden Houses and Relating Regulations
1891	M24	• Nobi earthquake(M8.0) Destroyed houses:142,177 Lost lives:7,273	• Proposal by Daikichi Taki : 1)No more use "Pass though Nuki", 2)Use brace and sub-column, 3)Use sill, 4)Use timber for roof system.
1893	M26		
1894	M27	• Shonai earthquakes(M7.0) Destroyed houses:3,858 Lost lives:726	• Shinsai-yobo-chosa-kai : 1)Use sill, leg brace, 2) Fix brace by bolt, 3)Use lighter roof, 4)Use clear joint, 5)Recommend to use diagonal members
1896	M29	• Sanriku earthquakes(M6.8) Destroyed houses:1,844 Lost lives:22,072	
1916	T 5		• Prof.Toshikata Sano (Kaoku-taishin-kouzou-ron) : Proposal of earthquake resistance design, For timber structures, use lighter roof, 2)use steel fastener for joints, 3)3D Use of diagonal member.
1920	T 9		
1923	T12	• Great Kantō earthquake(M7.9) Destroyed houses:128,266 Lost lives:142,807	Shigaichi-kenchikubutu-ho (Origin of current Building Standard Law: BSL) : Part of Prof.Sano's proposal was adopted, but no earthquake resistance design concept was involved.
1924	T13		
1927	S 2	• Tango earthquakes(M7.3) Destroyed houses:12,584 Lost lives:2,925	• Amendment of 'Shigaichi-kenchikubutu-ho': Use brace or elbow brace without respect to story of building.
1930	S 5	• Kita-izu earthquakes(M7.3) Destroyed houses:2,165 Lost lives:272	
1931	S 6	• Nishi-saitama earthquakes(M7.0) Damages unknown	• Heigaku Tanabe (in Taishin-kenchiku-mondo) 1)Plane allocation of house should be simple and well balanced, 2) Set as much of infill as possible and assemble both directions, 3) Uniform distribution of shear walls, 4) Coincident of upper shear walls' location with lower one, 5) Location of ladder and use it as diagonal member.
1933	S 8	• Sanriku earthquakes(M8.1) Destroyed houses:2,346 Lost lives:3,064	
1940	S10		

M: Meiji Era, T: Taisyo Era, S: Syowa Era (M : Magnitude)

(to be continued)

Table 1 Earthquake Damages on Peoples as well as Wooden Dwelling Houses in Past 100 years.

Christian Era	Domestic Era	Earthquake & Damages	Proposals for Enhancing Earthquake Resistance of Wooden Houses and Relating Regulations
1943	S13		• Heigaku Tanabe in Kenchikubutu-taishin-kozo-yoran 1) Practical stress distribution in wooden frame structure, 2) Proposal of western style Shin-Kabe
1944	S14	• Tou-nankai earthquakes(M7.9 ~ 8.0) Destroyed houses:17,599 Lost lives:1,223	
1945	S15	• Mikawa earthquakes(M6.8) Destroyed houses:7,221 Lost lives:2,306	
1946	S16	• Nankai earthquakes(M8.0) Destroyed houses :11,506 Lost lives: 1,464	
1948	S18	• Fukui earthquakes(M7.1) Destroyed houses :36,184 Lost lives:3,769	
1950	S25		Establishment of Building Standard Law (BSL): in the Article 46, necessary shear wall quantities were first determined.
1952	S27	• Tokachi-0ki earthquakes(M8.2) Destroyed houses2,139 : Lost lives:33	
1959	S34		• Amendment of Article in BSL. Experimental results on shear walls by Dr.Hisada were taken into the amendment.
1964	S39	• Niigata earthquake(M7.5) Destroyed houses : 1,960 Lost loves:26	
1968	S43	• The 2nd Tokachi-0ki earthquakes(7.9) Destroyed houses :676 Lost lives:52	
1971	S46		• Amendment of Article in BSL. Necessary shear wall quantities for wind load were amended. Static as well as dynamic experiments on various shear walls were performed by Watabe, Kawashima in Building Research Institute (1971)
1974	S49	• Izu-hanto-oki earthquakes(M6.9) Destroyed houses :134 Lost lives:38	
1978	S53	• Miyagiken-oki earthquakes(M7.4) Destroyed houses :1,183 Lost lives28	
1979	S54		• National scale research project on seismic resistance of wooden residential houses was executed by collaborating with BRI, FFPRI and Disaster preventing research centre. Full scale destructive test on wooden dwelling houses by Murota, Arima, Sato in BRI and evaluation tests for various shear walls by Hirashima, Kanaya, Hatayama and Kamiya in FFPRI.

M: Meiji Era, T: Taisyō Era, S: Syōwa Era, H: Heisei (M : Magnitude)

(to be continued)

Table 1 Earthquake Damages on Peoples as well as Wooden Dwelling Houses in Past 100 years.			
Christian Era	Domestic Era	Earthquake & Damages	Proposals for Enhancing Earthquake Resistance of Wooden Houses and Relating Regulations
1980~81	S55~56		<ul style="list-style-type: none"> • New seismic design method was introduced into BSL: Contents on wooden structures were widely amended by reflecting above mentioned research project. Experimental results on various shear walls tested by FFPRI team were published in Journal of Japan Wood Research Society. (1981~1982)
1982			<ul style="list-style-type: none"> • New BSL was released.
1983	S58	<ul style="list-style-type: none"> • Nihonkai-cyubu earthquakes(M7.7) Destroyed houses :934 Lost lives104	
1993	H 5	<ul style="list-style-type: none"> • Hokkaido-nansei-oki earthquakes(M7.8) Destroyed houses :1,144 Lost lives:230	
1995	H 7	<ul style="list-style-type: none"> • Hyougoken-nanbu earthquakes(M7.2) Destroyed houses : 177,000 Lost lives:5,400	<ul style="list-style-type: none"> • Full scale shaking table test on wooden post & beam dwelling house was first performed at special testing facility in Tadotsu, Shikoku, by applying actually measured seismic acceleration record.
2000	H12		<ul style="list-style-type: none"> • New BSL was released by reflecting damage analysis on Hyougoken-nanbu earthquake. 1) Check for basement due to ground strength, 2) Check for well balanced allocation of shear walls, 3) Check for strength performance of column-sill as well as column-beam joints.
2004	H16	<ul style="list-style-type: none"> • Niigatoken Chuetsu earthquake (M6.8) Destroyed houses : 13,400 Lost lives:40	<ul style="list-style-type: none"> • Automatically measured seismic intensity degree was recorded as 7 This automatic estimation system was newly introduced into various earthquake hazardous area after Hyogoken-nanbu earthquake. Until this time, seismic intensity degree was determined by human judgement.
2007	H19	<ul style="list-style-type: none"> • Noto Hanto earthquake (M6.9) Destroyed houses : 12,000 Lost lives:1	<ul style="list-style-type: none"> • Automatically measured seismic intensity degree was recorded as 6+

First concept shown in Fig.1 introduced for estimating seismic force was called as “fixed seismic intensity method”, which implies that acceleration “ a ” in wooden house was assumed to be constant without respect to its height, i.e. the ground acceleration was believed to be held good up to any elevation. It is well-known fact that this concept is now incorrect, but until recently most constructions were designed based on this insufficient concept. **Figure 2** shows a never forgetting example caused by this insufficient design concept.

Figure2 Collapse of a 635m section of single-piered bridges (Photo is taken from records of the 1995 Great Hyougoken-nanbu Earthquake Disaster edited by Architectural Institute of Japan & Japan Society of Civil Engineers)¹⁾.

Note: It is said that this single-piered bridges was designed before new seismic design method was introduced in 1980.²⁾







2. Precepts from the 1995 Great Hyogoken-Nanbu Earthquake

It was the 1995 Great Hyogoken-nanbu earthquake that gave strong emotion to make scientist, timber engineers and wooden house developers devote themselves into sincere research & development for enhancing seismic performance of wooden residential houses. As shown in Table1, 177,000 residential houses were collapsed and more than 5400 peoples were killed by the earthquake. Of collapsed wooden residential houses, majority was categorized into so-called “conventional post & beam structures”. Furthermore, it has gradually appeared that many of them were built before 1980, when the new seismic design method was adopted in the revised Building Standards Law as shown in Table1.

Table2 is a famous implication written by professor Sakamoto⁴⁾ to overview damage pattern of wooden residential houses observed in the 1995 Great Hyogoken-nanbu earthquake. From this table, it is appeared that “wooden residential houses built during 1950’s or 1970’s were, more or less, collapsed by devastating energy of the earthquake.

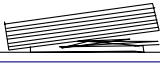
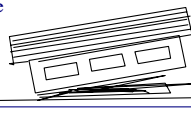
Table2 Damage pattern of wooden residential houses observed in the 1995 Great Hyogoken-nanbu earthquake

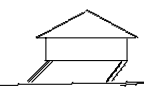
Construction type	Conventional Post & Beam Structure			Others	
Period	1950's	1970's		1960's ~	
Roof	Roofing mud + tiles	Roofing mud + tiles	Roofing mud+tiles, slates		
Wall	Mud wall with bamboo lath finished by plaster, weatherboar, without bracing	Mud wall with bamboo lath,wood lath.+ finished by mortar, with bracing	wood lath + mortar , sheathing + insulation board. mostly with bracing	2x4	Prefab
Use					
Residential Housing Loan Corporation	Collapsed mostly 	Collapsed a lot 	Collapsed a bit Big damage was a little	Big damage was a little	
Residential house with narrow frontage		Residential type civilized house (mini-development)  Large deformation a lot			
Condominium	Single story condominium collapsed mostly 	Apartment type civilized house  Collapsed mostly			Big damage was a little
Residential with store	Collapsed mostly (Many 2F extended) 	Collapsed a lot and largely deformed  			

3. Existing wooden residential houses built in accordance with old seismic resistance concept

Most wooden dwelling houses built before 1980’s were constructed in accordance with old seismic resistance concept as shown in Fig.1. After experienced devastating attacks by a series of earthquake, however, effort for revising old seismic resisting concept into new one has been paid at first by research scientists in Building Research Institute in 1970’s, then a kind of task force combined with scientists in Forest Research Institute and Disaster Preventing Research Center in Tsukuba was set up for evaluating performance of various shear walls. Finally in 1980, a new seismic resisting design concept was proposed based on the latest earthquake engineering. In the new concept, acceleration in building induced by earthquake was expressed as a function of elevation, stiffness, natural period of the building, ground properties and so on, thus it should be no more constant along elevation of building as has been stated in the old concept. This new concept was also accepted in designing wooden residential houses, and required shear wall amount (length) for earthquake force was revised into right values. At the same time, shear resistance factors of various shear walls were newly admitted on the basis of a series of experimental and theoretical research results obtained by task force jobs^{5)~8)}.

Figure 3 shows simple comparisons between old concept and new concept for seismic resistance and how different the required shear resistance capacity for each story against seismic force. For example, let assume mass distribution of 3 story wooden house as shown in Fig.3. (This assumption is not realistic, of course). In the case of old seismic resistance concept, required total shear resistance capacity at 1st floor is 5200kgf. While in the case of new seismic

concept in which acceleration due to earthquake distributes along elevation, required total shear resistance capacity for 1st floor was estimated as 6720kgf. This means that 6720/5200=1.3 times shear wall amount is necessary for resisting against same intensity of earthquake. This also implies inversely that the wooden structures built before 1980's had insufficient amount of shear wall, thus they will have higher probability of collapse by any devastating earthquake attacks even if they had been constructed by keeping Building Standard Law rigorously at that time.

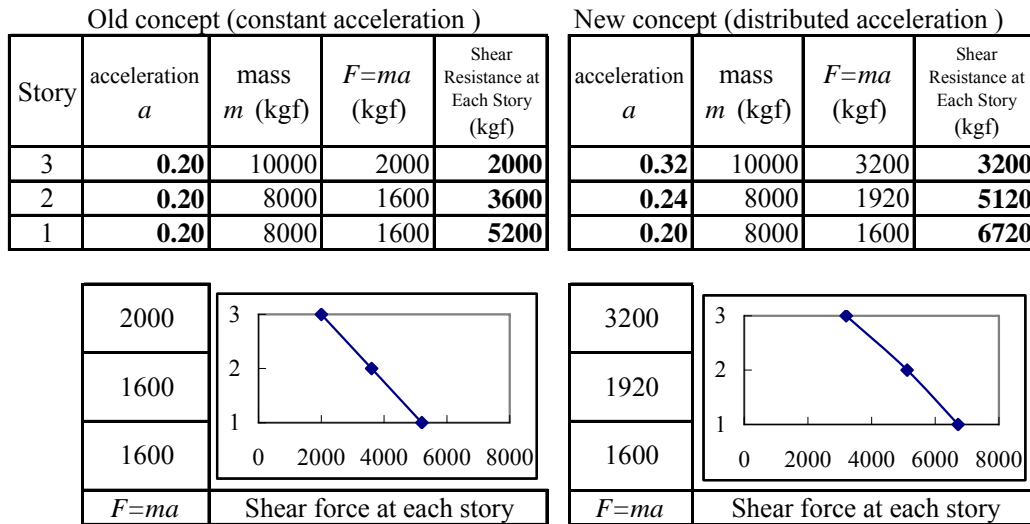

Fig.3 Comparison between old seismic resistance concept and new one.

This kind of technical insufficiency on wooden residential houses still remains in our country as one of the most serious headache problem and probably the only possible way for making existing wooden residential houses, whose ultimate performance were not enough, survive from huge earthquake attack will be “on-site reinforcement of shear walls” by employing all possible means. Recent continuous earthquake attacks, unfortunately however, in Niigata (2004 Niigataken chuetsu earthquake), Ishikawa (2007 Noto-hanto earthquake) and also Niigata (2007 Niigataken chuestu-oki earthquake) did force us to recognize serious realities that the above mentioned anxious were still reaming in everywhere in our country.

4. Improvement of Seismic Performance of Wooden Residential Houses

Fortunately, however, we have a good possibility for making our wooden houses survive from anticipating huge earthquake attacks. **Table 3** shows a history of change of required amount of shear wall in past 20 years. We can see that the required amount of shear wall was increased so much since 1980, especially for those having heavy weight on roof or wall. At present, those values became almost more than two times compared with those issued at first in 1950.

Table 3 Change of required amount of shear wall (unit: cm/m²)

Type of wooden structure	Year at BSL established or revised	Single story	Two story		Three story		
			2nd story	1st story	3rd story	2nd story	1st story
Wooden structure with heavy wall, heavy roof, or mud storehouse	1950	12	12	16	12	16	20
	1959	15	15	24	15	24	33
	1980	15	21	33	24	39	50
Wooden structure with light roof (metal, slate or wood single roofing)	1950	8	8	12	8	12	16
	1959	12	12	21	12	21	30
	1980	11	15	29	18	34	46

BSL: Building Standard Law

Required shear wall amount : 1cm shear wall has a 130kgf resistant against horizontal force

It might be possible to believe that the wooden residential houses built after 1980 will have a performance as much

as two times compared with those built before 1980. Moreover, very rigorous amendment of BSL done in June 2000 for improving seismic performance of conventional wooden post & beam structures seems to give fairly good effects on preventing story collapse of newly constructed wooden houses, judging from observations on damages of wooden residential houses caused by recent earthquakes.¹¹⁾ The amendment introduced in June 2000 was as follows:

a) Check out the foundation and base structure

Up to recently, little attention has been paid on the foundation and base structures when wooden dwelling houses were structurally designed. Since in June 2000, it became responsible to check the foundation strength and choice of relevant basement structures (Table.4).

Table4 Specification of concrete foundation for wooden conventional post & Beam structure

Foundation should be continuous reinforced concrete structure			
Foundation without steel can be used if ground strength larger than 70 kN/m ² , in case of the ground without possibilities of uneven-sink			
It should have continuous foundation under sill			
Width of footing should be larger than the following figure			
F	width of footing (cm)		
Allowable long term compression strength of ground	single story	two story	other (three story)
30kN/m ² ≤ F < 50kN/m ²	30	45	60
50kN/m ² ≤ F < 70kN/m ²	24	36	45
70kN/m ² ≥ F	18	24	30

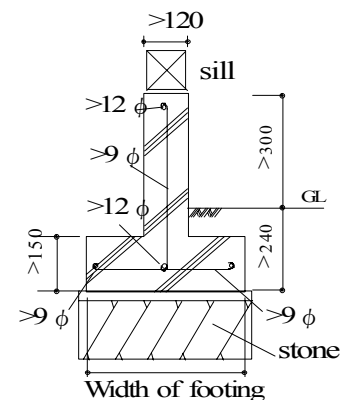

b) Check out the necessary shear wall quantity

The quantity of total shear wall length in the relevant floor area might be larger than the required shear wall capacity for the relevant floor area. At the Article 46 in the BSL, required shear wall length per unit area for standard dwelling houses are given by taking standard mass, floor area and theoretically presumed acceleration in each story into considerations for a simulation. It is confirmed that the current required shear wall quantity amended in 1981 was reasonable from experiences of past earthquakes.

c) Check out the eccentricity of shear wall arrangement

Before the 1995 Great Hyogoken-nanbu earthquake, there were no regulations on the balance of shear wall arrangement. Only a spiritual regulation such as “Shear walls should be placed with a better balance” was reminded;. At present, unbalanced arrangement of shear walls must be rejected using the following alternative checking methods. One method is so-called “1/4 area balance check method”. The other method is to calculate the eccentricity coefficient.

Fig.4 1/4 area balance check method Shear wall fulfill ratio at both region-a and region-b should be estimated (existing wall quantity/required wall quantity) to make sure that the ratio of fulfill ratio-a/fulfill ratio-b should be bigger than 0.5.

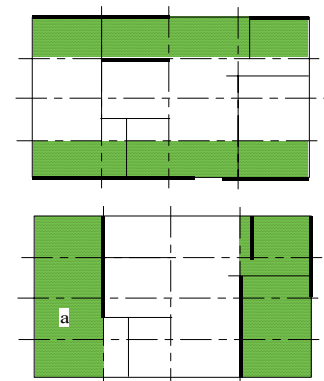

Fig.4 1/4 area balance check method

d) Check out the strength capacity of connections

Accepting technical reviews on the 1995 Great Hyogoken-nanbu earthquake, regulations for checking out the strength capacity of each connection was prescribed in the Notification No.1460 of BSL in 2000. Pullout force at each joint between column and sill or column and horizontal member must be calculated using assigned simple equations, then appropriate steel fasteners must be attached at the relevant joint parts. This requirement implies that any preliminary failures at connection should be avoided before shear walls can achieve their full shear resistance capacity. Thus, compared with past specification, current wooden dwelling houses tended to contain a lot of steel fasteners at each connection.

In the 1955 Great Hyogoken-nanbu earthquake, a lot of insufficient shear wall was observed everywhere. We presumed that at first this kind of insufficient connection was broken due to pullout motion then push down towards outside of sill as shown in Fig.5. Once the brace lost its structural function, story collapse was easily occurred..

At present, in the case of newly constructed wooden post & beam structures, premature pullout failure at column-sill joint or brace-sill joint prior to yielding of shear wall itself should be rigorously avoided, hence those important joints must be connected using such a strong fastener called as “hold-down connector” as shown in Fig.6.



Fig.5 Poor connection between brace and sill or column observed in the 1955 Great Hyogoken-nanbu earthquake.

5. Alternative Methods for Preventing Damage of Earthquake

5.1 Seismic (Base) isolation method

Above-mentioned improvement method is called as “earthquake resistant method”, and it seems to be most popular and usual method current in Japan because it is most economical.

While, in addition to this, we have two more effective and intelligent methods for responding to earthquake. The first method is called as “seismic (base) isolation method”, in which a special insulation mechanism start to acts, if the acceleration induced by earthquake exceeds some limiting level, to cut off transmission of the acceleration onto upper wooden structure. For this end, usually specially developed rubber or/and sliders are used for insulation wooden structure from foundation. Fig.7 shows an example of “seismic isolation” equipment being used widely in Japan¹⁰⁾.

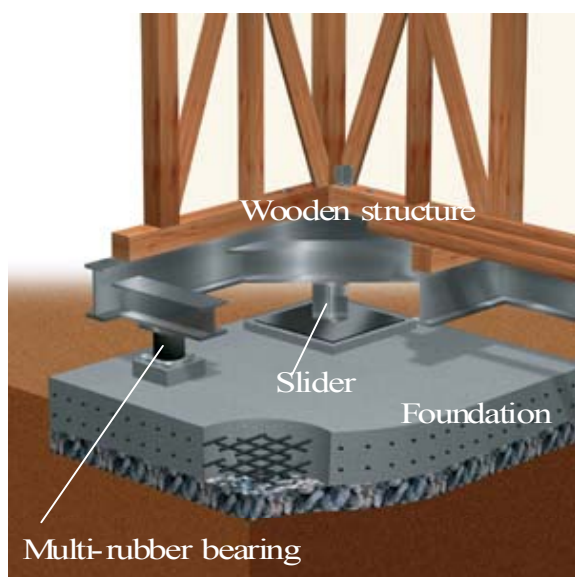

Fig.7 Seismic isolation equipment (Picture by courtesy of Ichijyo Komu-ten)



Fig.6 Example of “hold-down connector” set at column-sill joint in a wooden conventional post & beam structure. This connector, for example, can be used to sustain 20kN pullout force.

5.2 Seismic energy dumping method

In this method, inputted seismic energy is intentionally dissipated by various damping mechanism which has already built-in some particular parts of building such as inside of shear wall, a part of brace, beam-column joint and so on. Usually, for this end highly viscous material like rubber or oil dumper is used for dissipating seismic energy into thermal energy.

Fig.8 shows an example of seismic control equipment developed for wooden prefabricated house¹¹⁾. This equipment is hid in a shear wall so that usually cannot be seen from outside.

6. Closing remark

In this article, at first the author intended to introduce latest information how Japanese wooden residential houses have been improved safely against earthquake. Unfortunately, however, in preparing this article, we have had again severe damages on a lot of wooden residential houses in Kashiwazaki, Niigata by the 2007 Niigataken-chuetsu-oki earthquake. Thus the content was biased somehow into the past reviewing one to explain why this earthquake collapsed so many relatively old and heavy roofed wooden structures.

References

- 1) Special task committee of earthquake resistance of civil engineering structures.: “Proposal on earthquake resistance for civil engineering structures”, Japan Society of Civil Engineers, <http://www.jsce.or.jp/committee/earth/index-e.html>,
- 2) Special task committee of earthquake resistance of civil engineering structures. : “Explanation on the 2nd proposal on earthquake resistance for civil engineering structures”, Japan Society of Civil Engineers (in Japanese), <http://www.jsce.or.jp/committee/earth/index.html>.
- 3) Tatsuo Ohmachi: “Current State of Research on Earthquake Disaster Mitigation for Civil Engineering Structures”, Journal of Geography, 110(6), 876—884, 2001. (in Japanese)
- 4) Isao Sakamoto: “Characteristic points of the 1995 Great Hyogoken-nanbu earthquake and overview of damage on buildings”, Handout in The 27th Open Forum, Wooden Structures Research Forum, May 1995. (in Japanese)
- 5) Makoto Wtanabe and Kenichi Kawashima : Performance of Shear Wall in Wooden Post & Beam Structures, Report of Building Research Institute, No.59, pp.1-29, 1971. (in Japanese)
- 6) Yoshihiko Hirashima, Noriyuki Kanaya, Yoshio Hatayama, Fumio Kamiya: “The Performance of Wooden Frames with Bracings for Horizontal Shearing Force and Their Structural Analyses I. Racking tests of wooden frames”, Journal of the Japan Wood Research Society, 27(12), pp.845-854, 1981. (in Japanese)
- 7) Yoshihiko Hirashima, Noriyuki Kanaya, Yoshio Hatayama, Fumio Kamiya: “The Performance of Wooden Frames with Bracings for Horizontal Shearing Force and Their Structural Analyses II. Structural analyses of wooden frames”, Journal of the Japan Wood Research Society, 27(12), pp.855-862, 1981. (in Japanese)
- 8) Yoshihiko Hirashima, Noriyuki Kanaya, Yoshio Hatayama, Fumio Kamiya: “The Shear Performance of Wooden Frames Covered with Sheet Materials or Plaster and Their Structural Analyses I. Racking tests of wooden frames”, Journal of the Japan Wood Research Society, 28(2), pp.97-106, 1982. (in Japanese)
- 9) Kohei Komatsu et.al.: “Damage on the wooden structures in Niigatken Chuetsu earthquake”, p.69-79, The 2004 Symposium Handout, Timber Engineering Research Group, JWRS, Kyoto, March 2005. (in Japanese)
- 10) Shigeru Hirano and Naoto Ando : “Full-scale shaking table tests of a Japanese post and beam wooden house II: Dynamic properties of base-isolated wooden house and quake-free effect by real and simulated seismic motions”, Journal of the Japan Wood Research Society, 49(2), 117-130, 2003 (in Japanese)
- 11) Hisamitsu Kajikawa and Haruhiko Ogawa: “Development of Damping Wall (MGEO) in Misawa Homes”, Proceedings of the 10th Timber Engineering Forum 2006, Tokyo, 72-75, November 2006. (in Japanese)



Fig.8 Seismic control equipment for wooden prefabricated house. (Photo by courtesy of Misawa home)