

EUROPEAN COLLABORATIVE ACTION

URBAN AIR, INDOOR ENVIRONMENT AND HUMAN EXPOSURE

Environment and Quality of Life

Report No 30

**Framework for health-based ventilation guidelines
in Europe**



2020

This publication is a Technical report by the Joint Research Centre (JRC), the European Commission's science and knowledge service. It aims to provide evidence-based scientific support to the European policymaking process. The scientific output expressed does not imply a policy position of the European Commission. Neither the European Commission nor any person acting on behalf of the Commission is responsible for the use that might be made of this publication. For information on the methodology and quality underlying the data used in this publication for which the source is neither Eurostat nor other Commission services, users should contact the referenced source. The designations employed and the presentation of material on the maps do not imply the expression of any opinion whatsoever on the part of the European Union concerning the legal status of any country, territory, city or area or of its authorities, or concerning the delimitation of its frontiers or boundaries.

JRC Science Hub

<https://ec.europa.eu/jrc>

JRC99207

EUR 27640 EN

PDF	ISBN 978-92-79-54143-8	ISSN 1831-9424	doi:10.2788/17476
Print	ISBN 978-92-79-54144-5	ISSN 1018-5593	doi:10.2788/590104

Luxembourg: Publications Office of the European Union, 2020

© European Union, 2020

The reuse policy of the European Commission is implemented by the Commission Decision 2011/833/EU of 12 December 2011 on the reuse of Commission documents (OJ L 330, 14.12.2011, p. 39). Except otherwise noted, the reuse of this document is authorised under the Creative Commons Attribution 4.0 International (CC BY 4.0) licence (<https://creativecommons.org/licenses/by/4.0/>). This means that reuse is allowed provided appropriate credit is given and any changes are indicated. For any use or reproduction of photos or other material that is not owned by the EU, permission must be sought directly from the copyright holders.

All content © European Union, 2020

How to cite: Carrer, P., Wargocki, P., De Oliveira Fernandes, E., Hänninen, O., Kephelopoulos, S., Allard, F., Asikainen, A., Asimakopoulos, D., Asimakopoulou, M.-N., Bischoff, W., Braubach, M., Brelik, N., Breannan, D., Fanetti, A., Hartmann, T., Héroux, M.-E., Jantunen, M., Leal, V., Mustakov, T., Palkonnen, S., Popov, T., Rolland, C., Salari, M., Santamouris, M., Santos, H., Savli, R. and Seppänen, O., *European Collaborative Action - Urban Air, Indoor Environment and Human Exposure, Report No 30, Framework for health-based ventilation guidelines in Europe*, EUR 27640 EN, Publications Office of the European Union, Luxembourg, 2020, ISBN 978-92-79-54143-8, doi:10.2788/17476, JRC88207.

EUROPEAN COLLABORATIVE ACTION

URBAN AIR, INDOOR ENVIRONMENT AND HUMAN EXPOSURE

Environment and Quality of Life

Report No 30

Framework for health-based ventilation guidelines in Europe

Prepared by:

Paolo CARRER, Milan University, Italy, **Pawel WARGOCKI**, Danish Technical University, Denmark (*HealthVent Coordinator*), **Eduardo DE OLIVEIRA FERNANDES**, Porto University, Portugal, **Otto HÄNNINEN**, National Institute for Health and Welfare, Finland, and **Stylianios KEPHALOPOULOS**, European Commission, Joint Research Centre, Italy

with the contribution of the HealthVent project's associated and collaborative partners:

Francis ALLARD, Université de la Rochelle, France

Arja ASIKAINEN, National Institute for Health and Welfare, Finland

Dimosthenes ASIMAKOPOULOS, National and Kapodistrian University of Athens, Greece

Margarita-Niki ASIMAKOPOULOU, National and Kapodistrian University of Athens, Greece

Wolfgang BISCHOFF, Universitätsklinik Jena, Germany

Mattias BRAUBACH, World Health Organisation – European Office, Germany

Nejc BRELIK, Federation of European Heating & Air-Conditioning Associations, Belgium

David BRENNAN, European Federation of Asthma and Allergy Associations, Belgium

Annaclara FANETTI, Milan University, Italy

Thomas HARTMANN, Universitätsklinik Jena, Germany

Marie-Eve HÉROUX, World Health Organisation – European Office, Germany

Matti JANTUNEN, National Institute for Health and Welfare, Finland

Vitor LEAL, University of Porto, Portugal

Tihomir MUSTAKOV, Asthma Association, Bulgaria

Susanna PALKONNEN, European Federation of Asthma and Allergy Associations, Belgium

Ted POPOV, Asthma Association, Bulgaria

Christine ROLLAND, European Federation of Asthma and Allergy Associations, Belgium

Maria SALARI, National and Kapodistrian University of Athens, Greece

Mats SANTAMOURIS, National and Kapodistrian University of Athens, Greece

Hugo SANTOS, University of Porto, Portugal

Roberta SAVLI, European Federation of Asthma and Allergy Associations, Belgium

Olli SEPPÄNEN, Federation of European Heating & Air-Conditioning Associations, Belgium



MANDATE: European Collaborative Action “**Urban Air, Indoor Environment and Human Exposure**” (formerly "Indoor Air Quality & its Impact on Man")

For 28 years now the European Collaborative Action ECA "Indoor Air Quality & its Impact on Man" has been implementing a multidisciplinary collaboration of European scientists the ultimate goal of which was the provision of healthy and environmentally sustainable buildings. To accomplish this task ECA is dealing with all aspects of the indoor environment including thermal comfort, pollution sources, the quality and quantity of chemical and biological indoor pollutants, energy use, and the ventilation processes which all may interact with indoor air quality. The work of ECA has been directed by a Steering Committee, which is hosted and managed by the European Commission's Joint Research Centre.

In order to provide a broader view on air pollution exposure in urban areas, both indoors and outdoors, the ECA Steering Committee decided to put more emphasis on the links between indoor and outdoor air quality and to focus its further work under a new title “*Urban Air, Indoor Environment and Human Exposure*”. The focus of the renewed activity is urban & indoor air pollution exposure assessment, seen as part of environmental health risk assessment and also considering the needs of urban and indoor air quality management. The new approach is supported by those activities of the Joint Research Centre in Ispra (Italy) dealing with exposure to physical and chemical agents, chemical assessment and testing and associated health effects.

This focussed activity proceeds within the broader framework of (i) health and comfort of the citizens, (ii) building technologies and source controls, and (iii) requirements of sustainability, energy efficiency and conservation of natural resources.

Specific examples of the working areas of ECA are:

- the relative importance of outdoor and indoor sources of pollution,
- the building-related interaction between outdoor urban air and indoor air,
- exposure to pollutants from the different urban outdoor and indoor sources and its relation to health and comfort.

By addressing such topics ECA will lay the ground for air quality management to minimise exposures to air pollutants. It will thus continue to contribute to pre-normative research needed by EC services and national authorities responsible for preventing pollution and promoting health, comfort and quality of life.

In this series the following reports have already been published:

- Report No. 1: Radon in indoor air. EUR 11917 EN, 1988. *
- Report No. 2: Formaldehyde emission from wood-based materials: guideline for the determination of steady state concentrations in test chambers. EUR 12196 EN, 1989. *
- Report No. 3: Indoor pollution by NO₂ in European countries. EUR 12219, EN1989.
- Report No. 4: Sick building syndrome - a practical guide. EUR 12294 EN, 1989.
- Report No. 6: Strategy for sampling chemical substances in indoor air. EUR 12617 EN, 1989.
- Report No. 7: Indoor air pollution by formaldehyde in European countries. EUR 13216 EN, 1990. *
- Report No. 8: Guideline for the characterization of volatile organic compounds emitted from indoor materials and products using small test chambers. EUR 13593 EN, 1991.
- Report No. 9: Project inventory – 2nd updated edition. EUR 13838 EN, 1991.
- Report No. 10: Effects of indoor air pollution on human health. EUR 14086 EN, 1991.
- Report No. 11: Guidelines for ventilation requirements in buildings. EUR 14449 1992, EN.
- Report No. 12: Biological particles in indoor environments. EUR 14988 EN, 1993.
- Report No. 13: Determination of VOCs emitted from indoor materials and products.
Interlaboratory comparison of small chamber measurements. EUR 15054 EN, 1993.
- Report No. 14: Sampling strategies for volatile organic compounds (VOCs) in indoor air. EUR 16051 EN, 1994.
- Report No. 15: Radon in indoor air. EUR 16123 EN, 1995.
- Report No. 16: Determination of VOCs emitted from indoor materials and products:
Second interlaboratory comparison of small chamber measurements., EUR 16284 EN, 1995.
- Report No. 17: Indoor air quality and the use of energy in buildings. EUR 16367 EN, 1996.
- Report No. 18: Evaluation of VOC emissions from building products –solid flooring materials., EUR 17334 EN, 1997
- Report No. 19: Total Volatile Organic Compounds (TVOC) in indoor air quality investigations. EUR 17675 EN, 1997
- Report No. 20: Sensory evaluation of indoor air quality, EUR 18676 EN, 1999.
- Report No. 21: European Interlaboratory Comparison on VOCs emitted from building materials and products, EUR 18698 EN, 1999.
- Report No. 22: Risk assessment in relation to indoor air quality, EUR 19529 EN, 2000.
- Report No. 23: Ventilation, Good Indoor Air Quality and Rational Use of Energy, EUR 20741 EN, 2003.
- Report No. 24: Harmonisation of indoor material emissions labelling systems in the EU, Inventory of existing schemes, EUR 21891 EN, 2005.
- Report No. 25: Strategies to determine and control the contributions of indoor air pollution to total inhalation exposure (STRATEX), EUR 22503 EN, 2006
- Report No. 26: Impact of Ozone-initiated Terpene Chemistry on Indoor Air Quality and Human Health, EUR 23052 EN, 2007
- Report No. 27: Harmonisation Framework for Indoor Products Labelling Systems in EU, EUR 25276 EN, 2012
- Report No. 28: Health Risks from Indoor Particulate (INDEX-PM), EUR 25588 EN, 2012
- Report No. 29: Harmonisation framework for health based evaluation of indoor emissions from construction products in the European Union using the EU-LCI concept, EUR 26168 EN, 2013

* out of print

Abstract

The present report describes the findings and recommendations of the HealthVent (Health-based ventilation guidelines for Europe) project that funded by the European Commission's Directorate General for Health and Consumers in the framework of the Second Programme of Community Action in the Field of Health (2008-2013). HealthVent developed a framework for health-based ventilation guidelines for public and residential buildings in Europe and assessed the consequences of implementing these guidelines, bearing in mind future trends in the built environment, including energy efficiency and environmental sustainability issues.

TABLE OF CONTENTS

EXECUTIVE SUMMARY.....	1
1.INTRODUCTION.....	4
1.1 Holistic approach to manage indoor air quality.....	5
(I)Outdoor Air.....	5
(II)The building as an air system.....	6
(III)Ventilation System.....	7
1.2 Ventilation as a mean to control indoor air quality – short historical perspective.....	8
1.2.1 Ventilation “theories”.....	9
1.2.2 Ventilation requirements.....	10
1.3 Current ventilation standards and their compliance in Europe.....	11
1.4 A need for health-based ventilation guidelines.....	14
2.FRAMEWORK FOR HEALTH-BASED VENTILATION GUIDELINES IN EUROPE.....	15
2.1 Background for setting health-based ventilation guidelines.....	15
2.2 Review of evidence for setting guidelines for health-based ventilation.....	17
2.2.1 Health-based air quality guidelines.....	17
2.3 Definition of “health-based ventilation rate” for a specific building.....	19
2.4 Definition of health related “base ventilation rate”.....	23
2.4.1 Health and ventilation - data from epidemiological studies.....	23
2.4.2 Humidity, human bio-effluents and ventilation.....	25
2.4.3 CO ₂ , human bio-effluents and ventilation.....	26
2.4.4 Selection of the base ventilation rate.....	30
2.5 Ventilation system type.....	32
2.6 Guidelines for design, operation and maintenance of ventilation systems.....	33
3. GUIDELINES’ IMPLEMENTATION, IMPACTS, POLICY RECOMMENDATIONS AND FUTURE RESEARCH NEEDS.....	38
3.1 Guidelines implementation.....	38
3.1.1 From the ventilation panacea to health-based ventilation.....	38
3.1.2 Integration of IAQ in energy audits, monitoring and performance.....	39
3.1.3 Performance-based evaluation of ventilation.....	41

3.2 Impacts.....	43
3.2.1 Impact on energy	43
3.2.2 Impact on elevated temperatures and moisture	47
3.2.3 Impact on filtration and penetration of outdoor air pollution	48
3.2.4 Potential for burden of disease reduction of different indoor exposure mitigation approaches	51
3.3 Recommendations and harmonisation needs across EU policies	55
3.4 Recommendations for future research	57
4.PATIENTS' PERSPECTIVE AND GUIDELINES' PROMOTION.....	60
4.1 Patients' perspective	60
4.2 Guidelines' promotion	61
5.CONCLUSIONS.....	63
6.REFERENCES.....	65
ACKNOWLEDGMENTS.....	70
APPENDIXES.....	72
APPENDIX 1: Short description of the HealthVent Project.....	73
APPENDIX 2: Ventilation typologies	75
APPENDIX 3: Overview of Standards and Technical Reports on Ventilation in Europe	79
APPENDIX 4: Members of the ECA "Urban Air, Indoor Environment & Human Exposure" Steering Committee.....	84

EXECUTIVE SUMMARY

Indoor air has been recognized as a significant determinant of population health. The burden of disease associated with major air exposures indoors in 26 European countries was recently accounted for loss of two million healthy life years annually¹. More than half of this is attributable to indoor exposure to pollutants originating from the outdoor air, the rest to the pollutants having indoor sources. The development of health-based ventilation guidelines has been recommended as one of the strategic priorities to reduce the burden of disease associated with exposure to air pollution.

Current ventilation standards in Europe do not adequately address the health-relevant aspects of indoor air quality. They provide different categories of comfort as the main decision criteria for designing ventilation requirements.

In the period 2010-2012, the HealthVent project that was funded by the European Commission's Directorate General for Health and Consumers developed a framework (concept, principles and foundations) of health-based ventilation guidelines for public and residential buildings in Europe. The consequences for health and energy of implementing these guidelines as well as policy needs for their effective implementation were discussed and presented in this report bearing in mind future trends in the indoor built environments as well as environmental sustainability issues.

The developed framework for health-based ventilation guidelines premises the reduction of the health risks associated to air exposure in buildings through proper source and exposure control. This control requires regulations to be developed and implemented in a co-ordinated framework where priority is given to source control measures and in second place to ventilation.

The guidelines are based on two fundamental prerequisites: (1) The air indoors must fulfil the requirements of the air quality (AQ) guidelines defined by the World Health Organization (WHO); and (2) The priority in terms of strategy for controlling indoor air quality and reducing the health risks associated with indoor exposures is given to source control. Ventilation is only used as a supplementary strategy to control exposure in support to the source control strategy.

"Health-based ventilation rate" is defined for a specific building when exposures to pollutants meet the WHO air quality guideline values through a two-level sequential approach integrating at first source control measures and then the appropriate ventilation rate.

A decision diagram was developed for determining the actual health-based ventilation rate for a specific building. This diagram provides possibilities to explore and implement source control strategies at both outdoor air and building level before the actual required health-based ventilation rate is determined.

The health-based ventilation rate cannot be lower than the *"base ventilation rate"* set at 4 L/s per person taking into account the results of review of epidemiological literature on

¹ Jantunen, M., de Oliveira Fernandes, E., Carrer, P. and Kephelopoulos, S. (2011). Promoting actions for healthy indoor air (IAIAQ), European Commission Directorate General for Health and Consumers, Luxembourg.

ventilation and health and modelling of exposure to human bio-effluents using CO₂ and moisture as decision criteria. The base ventilation rate is intended to dilute and exhaust occupant bio-effluents. It is a requirement that must always be satisfied. The base ventilation rate has been defined to create a true benchmark and reference point for defining ventilation rates based on health criteria admitting that rates lower than the base ventilation rate are not allowed.

The base ventilation rate will be sufficient to dilute and exhaust occupant bio-effluents provided that the level of pollutants from other sources than occupants meets the WHO AQ guideline values. If the WHO AQ guidelines are not met after all options of source control indoors have been exploited, then the actual health-based ventilation rate should be higher than the health-related base ventilation rate and calculated by selecting a multiplying factor (>1) of the base ventilation rate.

Health-based ventilation rate deals only with indoor air quality, is based on health requirements and must be treated separately from the air required for achieving thermal comfort (for cooling and/or heating).

The proposed framework for health-based ventilation guidelines do not specify which system for air delivery should be used. Cultural and climatic aspects should be considered in this decision process. The guidelines do require however that the air delivery does not increase the indoor air related health risk by creating exposure to pollutants that exceed the WHO guidelines values due to inadequate design, operation and maintenance procedures during the entire life-time of the building. The set of qualitative recommendations addressing these aspects of air delivery and minimizing the health risks are defined as a part of the guidelines.

Potential health implications of implementing the health-based ventilation guidelines were estimated by assessing the expected health gains on the basis of current levels of exposure to air pollution indoors. Source control of pollutants originating outdoors and indoors combined with the base ventilation rate was shown in simulations to halve the burden of disease caused by exposure to air pollutants indoors.

Potential energy implications of implementing the health-based ventilation guidelines were estimated by simulating energy needs for heating and cooling in relation to the ventilation needs. A comprehensive set of scenarios was examined with different parameters representing different performance of the ventilation systems and climatic conditions. Energy simulations showed that health benefits could be achieved if the health-based ventilation guidelines would be integrated with energy efficient designs.

Proper implementation of the health-based ventilation rate requires a holistic approach for the built environment ensuring that both indoor and ambient air quality is adequately addressed in all relevant documents and EU regulations, . This supports the potential development of the following policies and regulations: (a) common regulation on ventilation in Europe; (b) harmonized product labelling criteria; (c) building regulations requiring products with certified emissions already at the design stage; (d) regulations for indoor air quality maintenance, auditing and operation procedures; (e) criteria for energy requirements decoupling ventilation for indoor air quality control from systems for thermal comfort (heating/cooling); and (f) European guidance on proper design, construction, maintenance and inspections of ventilation systems.

Gaps in knowledge and further research needs concerning the investigation of the relationship between ventilation and health were identified. These are especially focusing on a proper characterization of exposure and ventilation, chronic health effects and subpopulations with special needs (i.e. vulnerable groups). Implementation of the framework for health-based ventilation guidelines will promote advancement of knowledge, technological innovation and will secure competitiveness of the European market. At the same time, the basic rights stated by WHO to grow up, live, work and learn in healthy indoor environments will be also secured.

1. INTRODUCTION

Every European citizen has right to indoor air quality (IAQ) that does not endanger health (WHO, 2000b). This is implicit in the basic right to grow up and live in healthy environments. Although buildings are supposed to create shelter and protection, they can cause increased risks to the quality of life of their occupants. The EnVIE (de Oliveira-Fernandes et al., 2009) and IAIAQ (Jantunen et al., 2011) projects estimated that the annual burden of disease (BoD) related to inadequate IAQ is ca. 2 million disability adjusted life years (DALYs)² in EU-26 and also attributed major health effects to pollutants and their sources (Table 1). Reducing this BoD is a high priority in the European health policies and has been recognized in both, the EU Environment and Health Action Plan 2004-2010 and the Public Health Program 2007-2013.

Table 1. Major health effects, pollutants and sources linked to IAQ exposures identified in the EnVIE study (Oliveira Fernandes et al., 2009).

	Tobacco smoke	Combustion particles	CO	Radon	Dampness and mould, dust mites, bioaerosols	(S)VOCs, indoor chemistry products
EFFECTS						
Allergic and asthma symptoms	●	●●●			●●●	●
Lung cancer	●	●●●		●●●		
Chronic obstructive pulmonary disease	●	●●●			●●●	
Airborne respiratory infections	●	●●●			●●●	
Cardiovascular morbidity and mortality	●	●	●●●			
Odour and irritation	●	●●●			●●●	●●●
SOURCES						
Outdoor air		●	●		●	●
Building/Equipment/Ventilation	●	●●●	●●●	●●●	●●●	●
Consumer products		●				●●●
Occupant behaviour and maintenance	●	●●●	●●●	●	●●●	●

² **Definition of DALY (Disability-Adjusted Life Year):** DALY is a metrics used to quantify the burden of disease from mortality and morbidity in a population. According to WHO one DALY can be thought of as one lost year of "healthy" life. The sum of these DALYs across the population, or the burden of disease, can be thought of as a measurement of the gap between current health status and an ideal health situation where the entire population lives to an advanced age, free of disease and disability. DALYs for a disease or health condition are calculated as the sum of the Years of Life Lost (YLL) due to premature mortality in the population and the Years Lost due to Disability (YLD) for people living with the health condition or its consequences.

1.1 Holistic approach to manage indoor air quality

In order to effectively tackle IAQ problems a holistic approach for the built environment is needed. It is important to understand that IAQ is the result of the interaction of three main systems (Figure 1): (I) *the ambient air*, that is the outdoor air around the building; (II) *the building* as an air system, i.e., an enclosure by itself or a cluster of several interconnected enclosures with their own indoor air and its own dynamics including its relationships with the outdoor air; and (III) the *ventilation system*, understood here as an extra technical solution (device or equipment) to control, when needed, the quantity and the quality of the air brought into the building. The first two systems are responsible for the source control of IAQ in a given building or a space while the ventilation system must be seen as an auxiliary system to provide service under specific requirements and therefore shall be treated separately from the building system.

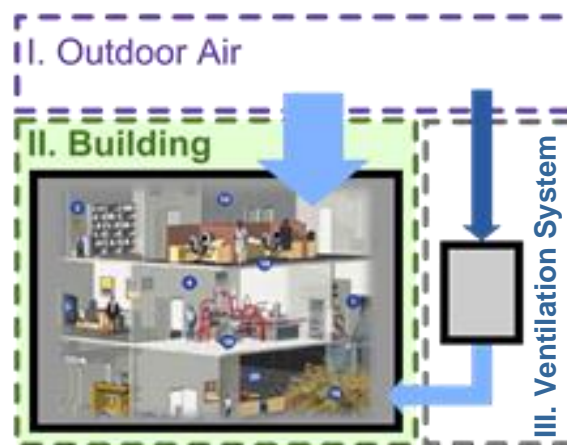

Figure 1. Relationship between the systems affecting indoor air quality in buildings.

(I) Outdoor Air

The quality of ambient air has been studied for more than 50 years involving significant efforts in research and development (R&D) dedicated to the management of emissions and the modelling of their transport and dispersion at local, regional and global scales. Despite the fact that the science behind the quality of the ambient air has progressed considerably, the progress made has been less successful from practical and societal perspectives. Specifically, this concerns the ambient air in cities where over 70% of the population in the OECD countries³ and 50% of the world population lives. For a considerable number of cities a satisfactory level of urban air quality has not been attained and the requirements set by the air quality guidelines defined by the World Health Organization (WHO) (2000; 2006) are not met.

³ The 30 member countries of the Organization for Economic Co-operation and Development (OECD) are: Australia, Austria, Belgium, Canada, Czech Republic, Denmark, Finland, France, Germany, Greece, Hungary, Iceland, Ireland, Italy, Japan, Korea, Luxembourg, Mexico, Netherlands, New Zealand, Norway, Poland, Portugal, Slovak Republic, Spain, Sweden, Switzerland, Turkey, United Kingdom and United States.

The management of the ambient air has been suffering from the contradictions of the current societal model, where the vectors of economic growth supported by the industrial production and its expressions in terms of urbanization and heavy traffic lines in cities seem to overwhelm the value of clean ambient air and its induced low health risks.

As in most cases the indoor air is also the ambient air which is brought inside the buildings directly by natural or mechanical forces, the quality of the air outdoors is thus paramount for the control of the indoor air quality. The literature has reported the importance of the relationship between outdoor (ambient) and indoor air (Jantunen et al., 2011) and recent policy developments at European Commission (EC) level in co-operation with WHO, envisage to build a strategy in the European Union (EU) to tackle jointly the quality of outdoor and indoor air, e.g. within the European Union's 7th Environment Action Plan

(II) The building as an air system

Buildings are normally considered as shelters providing a barrier to the influences and impacts of the outdoor environment. They should also be seen as spaces themselves with various indoor partitions, these latter being considered as particular air systems according to the differences in their uses and the corresponding specific requirements for the air indoors.

The indoor air quality of buildings is influenced through three different pathways:

- a) Location - i.e. the building's location in relation to the quality of the ambient air that may or may not respect the WHO air quality guidelines (such as in a city or metropolitan area in the proximity of a heavy traffic road or of an industrial area);
- b) Construction - through the choice of the construction's materials and components (ordinary and not ad hoc selected or labelled/certified materials and components with reduced emission of pollutants), and by taking care of the quality of the construction itself (i.e. by avoiding discontinuities on the insulation or cracks that may cause high levels of condensation or dampness and produce harmful biological contaminants (moulds and fungi) indoors, and by reducing the penetration of ambient air pollutants through infiltration);
- c) Adequacy to the uses - in terms of the building's ability to perform with proper human occupation density and control of the indoor activities.

Buildings' construction is certainly one of the most local technologies closely linked to the location, geography, climate and available resources in terms of construction materials and components. The objective of the European Commission's Construction Products Regulation (CPR) (CPR, 2011) is to facilitate cross-border trade of construction products and over-come trade barriers in EU and also to provide a common technical language in harmonised European product performance standards, for use by both manufacturers and regulators. CPR identifies seven essential requirements which should be met by the construction products with one of them on hygiene, health and environment. This recognises the importance that, besides mechanical resistance and stability that are a paramount requirement for any construction, also criteria such as health and energy efficiency should be also equally considered (Figure 2).

Indoor air pollution in buildings tends to be higher than of the outdoor air due to emissions from indoor sources which add to the pollution load created indoors by the incoming outdoor air. The indoor sources can be of various origins including among others: construction and cladding materials, activities indoors from the cleaning or cooking to the printing, combustion or smoking and human bio-effluents.

To assure healthy conditions for its occupants, all of the buildings' materials and equipment must be checked for their impact as emission sources of pollutants. Nowadays there exist labelling systems for the indoor emissions from construction products in some EU Member States and efforts have been undertaken to establish an EU harmonisation framework for these systems regarding the testing and the health based evaluation of indoor air relevant substances (ECA 27, 2012; ECA 29, 2013). These efforts are in line and directly following up on the well identified and widely recognised need to put emphasis on source control as the prime strategy to manage indoor air quality in buildings, as recommended by the EU funded EnVIE project (de Oliveira Fernandes et al., 2009).

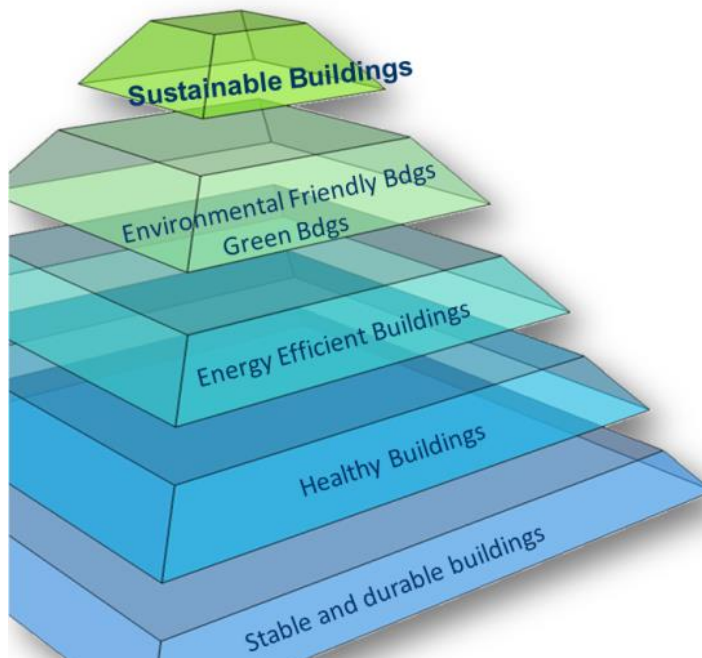

Figure 2. *Building requirements*

(III) Ventilation System

The ventilation system is meant here as the mechanical ventilation aimed at cleaning the incoming air in buildings whenever it is judged necessary at ventilation rates according to health based requirements or other pre-established criteria. In terms of buildings' source control strategy, the contribution of mechanical ventilation therefore resides to the cleaning of the incoming air. Concerning the operational performance and the quality of the ventilation system, it should be seen as an intrinsic service to be guaranteed by the system provider.

The ventilation system must be seen as a parallel option to the natural ventilation practice where outdoor air is transported indoors either automatically or manually by operable openings in the building envelope. As currently advocated, mechanical ventilation seems increasingly becoming the rule for cities with ambient air not respecting the WHO air quality guidelines. However, any rationale that may support a potential generalization of the use of mechanical ventilation in buildings must be first thoroughly considered and evaluated before adoption. In this perspective, the conditions of the air pollution in a particular location of a city and the time period, the level and type of occupation of the building must be taken into account. New policies and trends on the urban transportation and mobility structures and practices in cities that might lead to a progressively cleaner urban air should be also considered in parallel.

1.2 Ventilation as a mean to control indoor air quality – short historical perspective

Ventilation has been recognized as an important factor for indoor air quality. Already ancient Egyptians required use of ventilation for stone carvers to avoid exposures to particles and dust generated during their work. Hippocrates (460-377 B.C.) indicated adverse effects of polluted air in crowded cities and mines. During Roman times (1st B.C.), Sergius Orata developed hypocausts, under floor heating system to distribute heat uniformly in a house and most importantly to avoid combustion indoors and subsequently harmful exposures. In case of open fire indoors the minimum ratio of window to floor area was set and parchment above window was required during his times to assure the supply of air due to infiltration.

During Venetian time roof windows were developed while Leonardo da Vinci recognized that no animal can live in an atmosphere where a flame does not burn and that dust can cause damage to health, implying thus a need for ventilation.

In the 17th Century Wargentin expressed the common knowledge of that time that the expired air was unfit for breathing until refreshed. In the same Century, Gauger quoting Cardinal Melchior de Polignac remarked that it is not warmth but inequality of temperature and want for ventilation that causes maladies.

In 1756, Holwell described an accident in the Black Hole of Calcutta, a small dungeon where prisoners and soldiers were kept overnight in poor conditions, and 125 out of 146 died due to suffocation. During Crimean War (1853-1855) it was observed that there was faster spread of diseases among wounded soldiers in poorly ventilated hospitals. Higher morbidity and mortality was observed in overcrowded and poorly ventilated rooms. The importance of ventilation in small room volumes to avoid the death of people was also informed by Baer in 1882.

Few years later, Reid expressed the view that among mental anxiety and defective nutriment, deficient ventilation should be considered as one of the evil enemies of human race. Similar view was expressed by Griscom in 1850 who acknowledged that the deficient ventilation is fatal as it leads to spread of tuberculosis and other diseases. An effective treatment of tuberculosis using country fresh air was then achieved by Trudeau who opened the Airdonack Cottage Sanatorium in 1873.

Early in the 20th century Winslow and Palmer suggested that the ill ventilated rooms do not

create large discomfort but result in the loss of appetite. Later Winslow and Herrington observed similar result of appetite loss for food when heating the dust from vacuum cleaner.

In modern era the need for ventilation of indoor spaces is recognized in building codes and there are ubiquitous ventilation standards dealing with the issue. The ventilation rates are determined mainly to satisfy comfort requirements, specifically to improve the perceived air quality by reducing the % of dissatisfied occupants due to poor air quality and to reduce odor intensity.

1.2.1 Ventilation “theories”

Different theories have been put up through the last two to three centuries to explain the effects associated due to inadequate ventilation.

Miasma theory prevailed for a long time until XVIII-XIX century attributing cholera, chlamydia and black death to a noxious form of “bad air”. It was later displaced by the germ theory of disease after discovering of germs in the XIX century. In the early XVII century breathing was attributed to cool heart. In the same century Mayow attributed the effects observed to igneo-aerial particles that cause demise of animals.

One century later, in 1775, Lavoisier discovered two gases in air and attributed the effects of igneo-aerial particles to carbon dioxide (CO₂) and air stuffiness. The theory that CO₂ is a dominant cause of physiological effects of bad air remained dominant for nearly 100 years although it was acknowledged that other factors could also contribute to the effects observed. It prevailed until in the 1800s, when Pettenkoffer indicated that it is neither the deficiency of O₂ nor excess of CO₂ but the presence or lack of biological pollutants (from humans) which are responsible for vitiation of air. In 1872 Pettenkoffer and Saeltzer suggested CO₂ to be the surrogate for vitiated air, a stick for deleterious substances of unknown origin.

In 1887-1889 Brown-Sequard and d’Arsonval attributed anthropotoxin (the toxic effluvia - toxic substances in exhaled air) to be responsible for the effects reported through history in case of the lack of ventilation. Organic matter from and lungs and skins had been also proposed as poisonous by many others prior to the anthropotoxin theory. The theory was rejected by many experiments performed later by Haldane and Smith in 1892-1893, Billings in 1895 and Hill in 1913. They could not confirm that condensate of expired air could kill the animals, which was claimed by Brown-Sequard. The anthropotoxin theory was then superseded by the idea put up by Billings in 1893 suggesting that the purpose of ventilation is to dilute contagions emitted by humans thus to reduce the spread of infectious diseases.

The large body of research in the early XX century among others by Billings, Flugge, Benedict & Millner and Hill showed that lack of ventilation cause discomfort exemplified by unpleasant body odors and temperature while no negative physiological effects could be observed even at CO₂ levels as high as 1-1,5% (10,000 to 15,000 ppm). Lack of ventilation was consequently associated with the thermal effects and discomfort. Since studies of Lemberg and Yaglou in the 30s of the 20th century ventilation was required to merely keep body odors at acceptable level defined to be at moderate level.

In the 1980-1990s it was acknowledged that additionally to the body odors emitted by humans also other sources of pollution indoors should be considered to determine the ventilation requirements. However, the general principle of providing ventilation to reduce

discomfort and achieve acceptable air quality as perceived by humans was not changed. Ventilation was merely a question of comfort, not health.

1.2.2 Ventilation requirements

The ventilation requirements have varied throughout history also as a result of changes in ventilation theories.

In 1836 Tredgold suggested the minimum ventilation rate in mines which should satisfy physiological needs of a miner. This rate was set at 1.7 L/s per person of which 0.2 L/s was for purging the CO₂ from lungs, 1.4 L/s was for removing the moisture produced by the body and 0.1 L/s was for keeping the candle burning, thus 1.6 L/s per person was basically defined to account for and remove the body effluents.

In one of the first textbooks on ventilation and heating published in 1893, Billings provided minimum requirements for ventilation (Billings, 1893). He was very much concerned about the spread of infectious diseases, particularly tuberculosis, and proposed a minimum ventilation rate at 30 cfm/person (~14 L/s per person) while the recommended ventilation rate was as high as 60 cfm/person (~28.5 L/s per person). He also calculated that 50 cfm/person (~23.5 L/s per person) would keep CO₂ levels at 0.05% (550 ppm) thus the exhaled CO₂ would be kept at 0.02% (200 ppm) above outdoor levels. Since then, it never happened that the ventilation rates proposed by any ventilation standards or guidelines were so high.

One of the very first ventilation guidelines was proposed by the Chicago Commission on Ventilation in 1914. In 1923, these guidelines were re-confirmed by the studies and conclusions of the New York State Commission on Ventilation. Both documents attributed ill health to overheating rather than ventilation ("Had the temperature been controlled well, the ventilation requirements could be reduced"). The temperatures of 15-19 °C in window ventilated rooms were observed to cause lowest prevalence of respiratory illnesses. The guidelines recommended 20 °C with proper control of relative humidity for living rooms to reduce spread of infectious diseases. CO₂ was not recognized as a harmful agent when encountered in working practice and no harmful effects could be attributed to the expired air. Relative humidity was recognized as the most important factor regarding ventilation requirements for health. Recirculation was not acceptable if 100% of air was recirculated. Window-ventilated rooms with natural draft were the most preferred method for ventilation.

In times after the recommendation proposed by Billings the ventilation requirements varied considerably. After the 1979 world oil crisis, according to ASHRAE Ventilation Standards the ventilation requirements were as low as 2.5 L/s per person in 1981, and 4 L/s per person in the Nordic guidelines published one year later (Sundell, 1982). The 5 L/s per person in the 1946 American Standard Association Code reached 7.5 to 10 L/s per person which is approximately the standard in more recent times (Janssen, 1999). These latter rates to a large extent reflect studies which determined ventilation requirements for getting acceptable IAQ to avoid discomfort and odors caused by emissions from humans (i.e. human bio-effluents) and emissions from building materials and furnishing. For some time the same ventilation requirements were also acknowledged as effectively diluting of odors produced by tobacco

smoking. These ventilation rates match well with the widely accepted CO₂ concentration of 0.1% (1,000 ppm) proposed by Pettenkoffer as indicator of adequately ventilated rooms and CO₂ concentration of 0.07% (700 ppm) for bedrooms.

1.3 Current ventilation standards and their compliance in Europe

Current ventilation standards in Europe reflect the historical development that described ventilation criteria based on comfort and non on health endpoints, implicitly assuming that providing comfort requirements health needs are also fulfilled. There are 11 European standards (refer to either residential or non-residential buildings or both) and technical reports on ventilation directly relating to indoor air quality, i.e. directly addressing functional properties that influence indoor air quality (Table 2). There are also 24 documents defining mechanical properties and testing of ventilation systems and equipment. . Detailed summary of European ventilation standards and technical reports is given in Appendix 3.

Table 2. *European ventilation standards and technical reports related to air quality requirements*

European ventilation standards and technical reports related to air quality requirements	
CR 1752:1998	Ventilation for buildings - Design criteria for the indoor environment
EN 15251: 2007	Indoor environmental input parameters for design and assessment of energy performance of buildings addressing indoor air quality, thermal environment, lighting and acoustics
EN 13779:2007	Ventilation for non-residential buildings - Performance requirements for ventilation and room-conditioning systems
CEN/TR 14788:2006	Ventilation for buildings - Design and dimensioning of residential ventilation systems
EN 12097:2006	Ventilation for Buildings - Ductwork - Requirements for ductwork components to facilitate maintenance of ductwork systems
EN 13053:2006	Ventilation for buildings - Air handling units - Ratings and performance for components and sections
EN 15239:2007	Ventilation for buildings - Energy performance of buildings - Guidelines for inspection of ventilation systems
EN 15240:2007	Ventilation for buildings - Energy performance of buildings - Guidelines for inspection of air conditioning systems
EN 15665:2009	Ventilation for buildings - Determining performance criteria for design of residential ventilation systems
prEN 15780:2008	Ventilation for buildings - Ductwork - Cleanliness of ventilation systems
FprEN 779:2011	Particulate air filters for general ventilation - Determination of the filtration performance

Unless referred to in the national legislation, standards are sets of voluntary technical and quality criteria for products, services and production processes (they are also called as technical specifications). European Standards are published by the European Committee for Standardization (CEN) and coordinated by the technical committee CEN TC 156 ' Ventilation

for buildings'. The development of standards is business driven and is drafted by technical experts in the field. They are shaped by consensus among enterprises, public authorities, consumers, and trade unions, through a consultation process organized by recognized independent standardization bodies at national, European and international level. Each of the 30 National Standards Bodies, members of CEN, transposes any new European Standard (EN) into national standard (withdrawing any existing national standard that is in conflict with it). EU countries can also adopt their own regulations/codes describing ventilation requirements.

Standards which can be used for determination of ventilation rates (EN 15251, 2007; EN 13779, 2007) define different categories of comfort. The general rule applied to these documents is that a better indoor air quality (in terms of higher comfort) requires higher ventilation rates. Still criteria for indoor air quality, other than comfort parameters, are not well defined in the EN standards. Some general guidance on indoor air quality is given together with the levels of CO₂ and humidity but there exist actually no other generally accepted criteria and measuring methods for other indoor air pollutants.

Comparison of regulations on ventilation rates, indoor air pollutants, and indoor environment criteria in 16 EU Members shows that regulations are inconsistent. This has occurred even though the majority of the parameters included in these regulations have been already defined in European Standards, which were accepted during CEN voting process by national bodies (Brelj, 2012). The inconsistencies may result in problems for building designers and construction industry including increase in construction related costs. The difference between the lowest and the highest ventilation requirements for dwellings in 16 European countries is about 6 times (Figure 3). Large differences also observed in the ventilation requirements for other building typologies such as schools and offices (Seppänen and Brelj, 2011; Brelj, 2012). In addition, some countries have still no legal requirements regarding ventilation rates and use voluntary based ventilation rates.

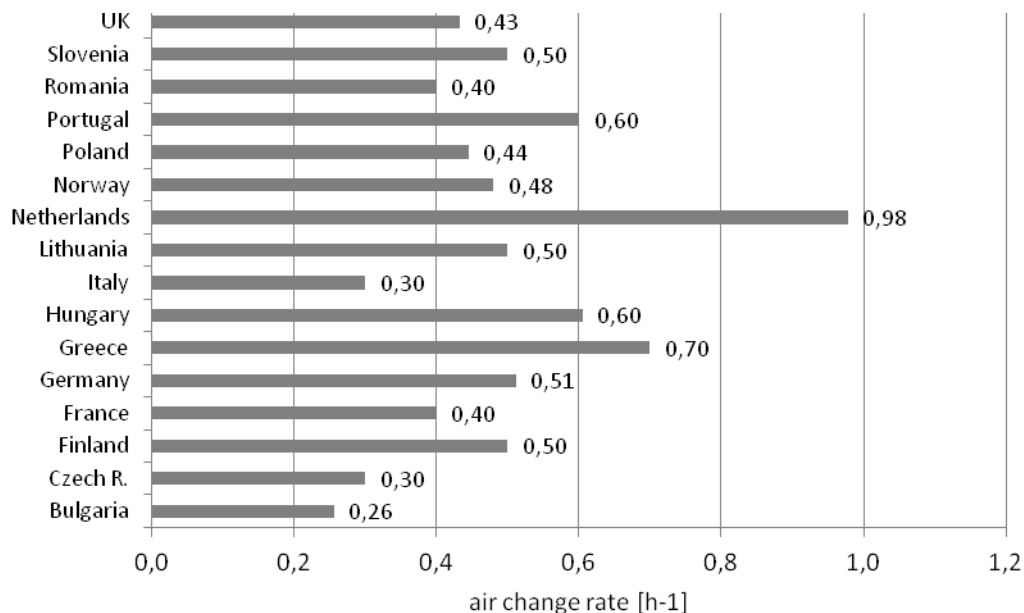

Figure 3. Comparison of ventilation requirements for dwellings in sixteen EU countries under the following assumptions: dwellings featuring a floor area of 90 m², height 2.5 m with 4 rooms, a kitchen, toilet, bathroom and 4 occupants. Ventilation rates range from 0.26 h⁻¹ in Bulgaria to 0.7 h⁻¹ in Greece

and 0.98 h^{-1} in the Netherlands. The presented rates and proportions are not much affected by changing the size of the dwelling (Seppänen and Brelih, 2011). To be noted that air change rate is a very rough unit which depends very much on the floor area per person (density of occupation), which varies dramatically in European dwellings (from 20 m^2 up to 50 m^2 per person). This illustrates the lack of rigor in the way the ventilation issue has been approached so far.

There are very limited data on the compliance of the ventilation rates in buildings with existing standards and regulations. Existing data is very limited and also not very representative as it was collected during different time periods and for different building typologies including relatively old and relatively new buildings (Seppänen and Brelih, 2012). In the case of dwellings, published data suggest that the measured mean ventilation rates range from 0.31 to 0.97 h^{-1} (which is about 5 to 15 L/s per person), with the lower rates being representative for naturally ventilated dwellings or dwellings with exhaust ventilation only. The upper and middle range is more typical for mechanically ventilated dwellings. The measured average ventilation rates in schools range from 1.5 to 9 L/s per person, again lower rates being more representative for naturally ventilated classrooms/schools. In case of offices the measured mean ventilation rates range from about 9 to 20 L/s per person with many of the buildings studied featuring mechanical ventilation systems.

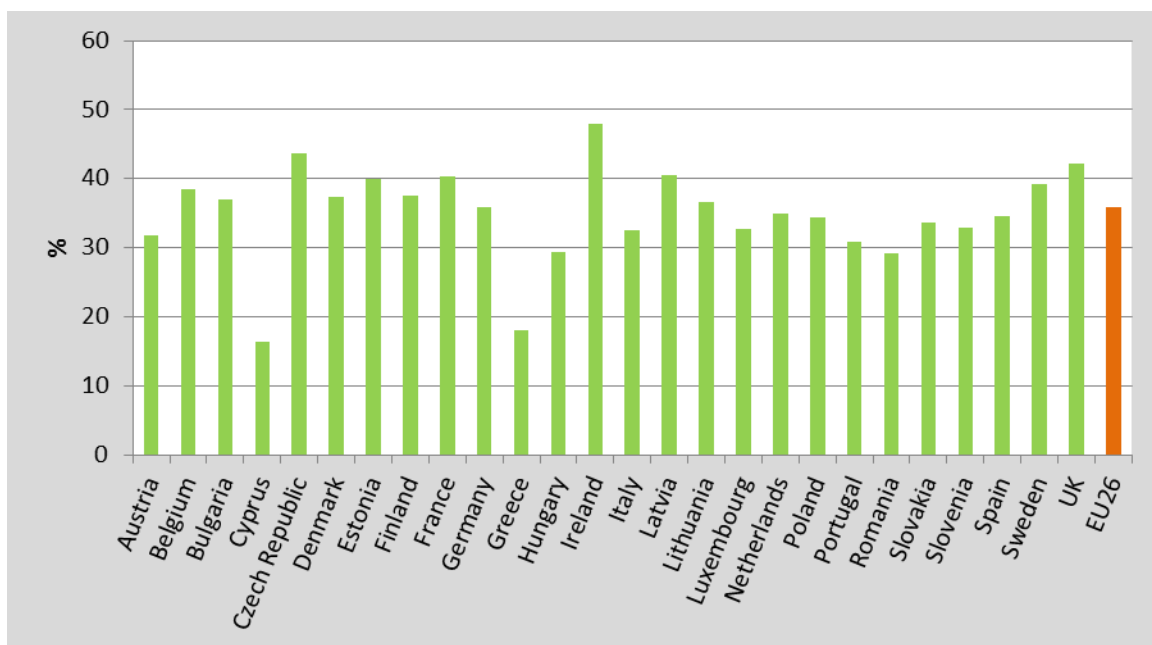

Figure 4. Estimated proportion of dwellings with ventilation rate below 0.5 h^{-1}

Considering the lack of data representativeness, it is difficult to judge how large is the part of the population in Europe that is exposed in buildings operating ventilation below the current requirements, thus the associated health risk thereof. To fill this gap, ventilation rates in dwellings were predicted using a regression/Bayesian model (Asikainen et al., 2013a, b). The location of the country, annual mean temperature and a gross domestic product were used to explain the variation between ventilation rates, with input data taken from national legislation and from actual ventilation measurements. National housing data were collected using EU housing statistics which showed that there are 133,321,781 residences with an

average (EU-26 weighted) floor area size of 86 m² linked to 2.5 inhabitants (the average floor area per person thus being 34 m²). The modeling showed that about 33% of dwellings are expected to have ventilation rates on average 0.5 h⁻¹, that corresponds to ventilation, on average, of 10 L/s per person (Figure 4).

In the national ventilation regulations of some EU countries are included requirements for indoor air quality. These requirements are either based on occupational limit values or other threshold limit values (TLVs) set internationally or nationally by relevant authorities (Seppänen and Brelih, 2011; Brelih, 2012). The number and type of regulated pollutants and their associated limit values vary greatly between EU countries (Table 3) and can be different from the air quality guidelines set by the World Health Organization (WHO, 2000; 2005; 2009; 2010). Some countries have not adopted any limit values regarding indoor air pollutants in their ventilation related national standards and regulations. Also the quality of outdoor air used for ventilation is not adequately addressed and the attempt to do so is only made in EN 13779 (2007).

Table 3. Examples of pollutants and their limit levels in ventilation related national standards and regulations in EU countries (units are expressed in mg/m³ unless otherwise indicated)

	BL ¹	CZ ¹	FI	FR	GER ¹	GR ¹	LIT	NOR	PT	ROM	SLO	UK
Ammonia	14	14	0.02 ²		14	350 ²	0.04				0.05	
Formaldehyde	1	0.5	0.05	0.01		6	0.01	0.1	0.1	0.035	0.1	
Carbon monoxide	40	30	8	10	35	11		10	12.5	6	10	10
Carbon dioxide	9,000	9,000	2,160		9,100	1,940		1,800	1,800	1,600	3,000	
Asbestos fb/dm ³			<500	5			0.1	≤1				
PM ₁₀			0.05			50	0.05		0.15		0.1	
Radon Bq/dm ³			200					≤100	400	140	400	
Styrene			0.001				0.002					
Benzene				0.002								
Naphtalene				0.01								
Ozone				0.2	0.2		0.03		0.2		0.1	0.1
Trichloroethylene				0.02								
Tetrachloroethylene				0.250								
Nitrogen dioxide					180			0.1				0.04
Volatile organic compounds (VOCs)								0.4	0.6			
Man-made mineral fibres								≤0.01 fb/m ³				
Legionella									100 UFC/L			
Total VOC											0.6	0.3

¹ 8-hour occupational exposure limit; ² ammonium & amines

1.4 A need for health-based ventilation guidelines

The EU funded EnVIE project (2003-2008) estimated that developing health-based ventilation guidelines to control exposure to pollutants from indoor and outdoor sources, indoor moisture and ensure comfortable indoor temperature would reduce the burden of disease (BoD) by approximately 0.7 million DALYs; and mandating the regular inspection and maintenance for all ventilation and air conditioning systems would further reduce it by 0.2 million DALYs (de Oliveira-Fernandes et al. 2009). Ensuring optimal ventilation in buildings across the EU Member States is thus a key to reduce health problems related to inadequate

indoor air quality. However, as mentioned in chapter 1.3, existing ventilation standards are based on comfort criteria and there are no European guidelines to recommend how buildings should be adequately ventilated for reducing health risks. Consequently, to effectively protect European citizens working, living and using non-industrial buildings from potential health risks and to implement relevant measures in building codes and regulations, health-based ventilation guidelines need to be established. These guidelines should not only prescribe the volume of air needed but also how ventilation systems should be designed to account for the different climate zones in Europe, building typologies and building's occupants needs, and also how they should be operated, maintained and commissioned to ensure their optimal performance. In the context of the emerging holistic approach to the built environment, to properly and efficiently manage indoor air quality, ventilation is considered as modifier of the exposure to indoor air pollution and represents a supplement to the primary strategy for reducing indoor air pollution at source. Ventilation removes and dilutes the pollution burden occurring indoors and can also bring indoors outdoor pollutants of the same or different type compared to those already existing inside the building. The removal/dilution rates through ventilation may be different for the various pollutants of relevance to the indoor environment but ventilation cannot reduce emissions, this being only possible by intervening at source.

Following the recommendations of the EnVIE project, a framework for health-based ventilation guidelines in Europe was developed in the context of the project HealthVent ("Health-Based Ventilation Guidelines for Europe) which, was launched in 2010, by the European Commission's Directorate General for Health and Consumers under the Second Programme of Community Action in the Field of Health (2008-2013). Appendix 1 provides a short description of the HealthVent project.

The present report, building on the findings of the HealthVent project, describes the framework for health-based ventilation guidelines and its implications for health and energy related policies and future research.

2. FRAMEWORK FOR HEALTH-BASED VENTILATION GUIDELINES IN EUROPE

In this chapter, the framework developed within HealthVent describing principles of setting health-based ventilation guidelines for public and residential buildings in Europe is presented.

2.1 Background for setting health-based ventilation guidelines

The definition of health-based ventilation guidelines is based on two basic considerations: one relating to air quality requirements in general and the second to strategies used to specifically control indoor air quality.

Air quality

The outdoor air penetrates indoors and contributes, along with indoor sources, to the air exposure inside buildings; therefore, clean outdoor air is a “prerequisite” for having clean air also indoors. Consequently, the air entering the indoor space must fulfil the requirements of Directive 2008/50/EC on ambient air quality (EC, 2008) and be in line with the WHO air quality guidelines (WHO, 1987; 2000 and 2005 editions).

Concerning the measures needed to guarantee appropriate levels of ambient air quality in European cities, an important issue to be faced is whether it makes more sense to delegate this obligation to the city managers and regulators (especially when a city is considered a ‘smart city’, or ‘sustainable’ or ‘intelligent city’) or provisions should be made at the level of buildings by adopting dedicated ventilation systems, including air filtering and washing air capabilities, so that buildings can be completely isolated from the influence of the ambient atmosphere. In such a context, mechanical ventilation should not be considered as a general imperative just because it is easier or simpler to filter ambient air.

The WHO “Guidelines for Indoor Air Quality: selected pollutants” (WHO, 2010) recommend health-based targets for nine air pollutants playing a specific relevance to indoor air and provide a scientific basis for legally enforceable standards in all regions of the World. WHO has specifically stated that its air quality guidelines for particulate matter recommended by the 2005 global update are also applicable to indoor spaces (WHO, 2010).

Strategies for controlling IAQ

It has been since long a common practice to use ventilation as a *panacea* to cope with indoor air pollution. This happens even if source control has been increasingly recognised as the prioritised strategy for controlling indoor air quality and reducing the health risks associated with indoor exposures, while ventilation should be only used as complementary and ultimate strategy. In principle and from a risk management point of view, source control is more effective, when applied at different levels and for different types of sources.

Control of outdoor air pollution should not create the need for the compulsory use of mechanical ventilation to ensure the filtering of the urban air penetrating into the buildings whenever the WHO air quality guidelines are not met. On the contrary, different forms of ventilation practices should be considered in relation to differences in climatic zones, architectural specificities and construction practices, cultural background and traditions.

For example, southern European countries have a long tradition of a frequent interchange of indoor/outdoor air over long time periods in the year through opening windows and doors.

Any difficulties to quantify and measure the ventilation rate to ensure that natural ventilation meets the requirements of existing ventilation standards and regulations by no means should become an excuse for the exclusive use of mechanical ventilation either.

In the context of the framework for health-based ventilation guidelines presented in this report, the proposed metrics for quantifying the ventilation rate is expressed in terms of air volume flow per unit of time per person (L/s per person) or (m³/h per person).

2.2 Review of evidence for setting guidelines for health-based ventilation

2.2.1 Health-based air quality guidelines

WHO air quality guidelines, both for outdoor and indoor air, and the EU-INDEX report have been used to define health-based exposure limits for air quality in Europe and the countries of the WHO Region (Table 4).

WHO air quality guidelines

In the period 1987-2006, three editions of air quality guidelines were issued by WHO recommending health-based exposure limits for a number of designated priority pollutants (WHO, 1987; WHO, 2000; WHO, 2006).

The primary aim of the WHO air quality guidelines is to provide a uniform basis for the protection of public health from potential adverse effects of exposure to air pollution, and to eliminate or reduce to a minimum level exposure to pollutants that are known or likely to be hazardous. These guidelines reflect the scientific knowledge available at the time of their development.

In 2010, WHO issued guidelines for indoor air quality for a number of pollutants (WHO, 2010) to reduce their associated health risks and provide a scientific basis for legally enforceable standards in all regions of the world.

The nine substances considered in the setting of the WHO indoor air quality guidelines in 2010 are the following: carbon monoxide, nitrogen dioxide, benzene, trichloroethylene, tetrachloroethylene, formaldehyde, naphthalene, polycyclic aromatic hydrocarbons (PAHs) and radon. These substances are commonly encountered indoor air pollutants and just a few of many hundreds of chemicals that can be found in indoor spaces. They have been selected based on knowledge about their relevant indoor sources availability of evidence regarding their associated health effects, and because they are commonly encountered at concentrations of health concern.

The expert group involved in the development of the WHO indoor air quality guidelines concluded that there is no convincing evidence of a difference in the hazardous nature of particulate matter (PM) from indoor sources as compared with those from outdoors and also that in presence of indoor sources of PM, the indoor levels of PM₁₀ and PM_{2.5} are usually higher than the outdoor PM levels. Therefore, the WHO air quality guidelines for particulate matter recommended by the 2005 global update were considered also applicable for indoor spaces, hence a new review of the evidence regarding indoor PM was not deemed as necessary (WHO, 2006).

The WHO guidelines on dampness and mould (WHO, 2009) concluded that "... persistent dampness and microbial growth on interior surfaces and in building structures should be avoided or minimized, as they may lead to adverse health effects. As the relationships between dampness, microbial exposure and health effects cannot be quantified precisely, no quantitative, health-based guideline values or thresholds can be recommended for acceptable levels of contamination by microorganisms. Instead, it is recommended that dampness and mould-related problems be prevented. When they occur, they should be remediated because they increase the risk of hazardous exposure to microbes and chemicals".

The EU-INDEX project

The EU-INDEX project (Critical appraisal of the setting and implementation of indoor exposure limits in the EU) was funded by the European Commission's Directorate General for Health and Consumers (DG SANCO) coordinated by the Joint Research Centre (JRC) in collaboration with a Steering Committee of leading European experts in the area of indoor air pollution (Koistinen et al. 2008; Kotzias et al. 2005).

This project identified priorities and supported the EU strategy and action plan in the area of indoor air pollution by setting up a three-level priority list of compounds to be regulated in indoor environments on the basis of exposure and health impact criteria and recommending potential exposure limits and risk management options for these compounds.

Table 4. Summary of existing air quality guidelines (the numbers in brackets indicate averaging time of measured levels)

POLLUTANT	INDOOR AIR QUALITY GUIDELINES		AIR QUALITY GUIDELINES	
	IAQ WHO (2010)	EU-INDEX (2005)	AQ WHO (2000)	AQ WHO (2005)
CO (mg/m ³)	100 (15 min)	100 (15 min)	100 (15 min)	
	60 (30 min)	60 (30 min)	60 (30 min)	
	30 (1 h)	30 (1 h)	30 (1 h)	
	10 (8 h)	10 (8 h)	10 (8 h)	
	7 (24 h)			
NO ₂ (µg/m ³)	200 (1 h)	200 (1 h)	200 (1 h)	200 (1 h)
	40 (1 y)	40 (1 w)	40 (1 y)	40 (1 y)
SO ₂ (µg/m ³)			500 (10 min)	500 (10 min)
			125 (24 h)	20 (24 h)
PM ₁₀ (µg/m ³)				50 (24 h)
				20 (1 y)
PM _{2.5} (µg/m ³)				25 (24 h)
				10 (1 y)
OZONE (µg/m ³)				100 (8 h)
RADON (Bq/m ³)	No safe level Reference level: 100 Not more than: 300			
Benzene (µg/m ³)	No safe level	No safe level Not more than outdoor level	UR 6 × 10 ⁻⁶	
Trichloroethylene (µg/m ³)	No safe level		UR 4.3 × 10 ⁻⁷	
Tetrachloroethylene (µg/m ³)	250 (1 y)		250 (1 y) 8000 (30 m)	
Toluene (µg/m ³)		300	260 (1 w) 1000 (30 m)	

Styrene ($\mu\text{g}/\text{m}^3$)		250	260 (1 w) 70 (30 m)	
Xylenes ($\mu\text{g}/\text{m}^3$)		200		
Formaldehyde ($\mu\text{g}/\text{m}^3$)	100 (30 min)	30 (30 min)	100 (30 min)	
Naphthalene ($\mu\text{g}/\text{m}^3$)	10 (1 y)			
Polycyclic aromatic hydrocarbons (PAHs)	No safe level		8.7×10^{-5} per ng/m^3 of B[a]P.	

EU-INDEX recommended guideline values and risk management options for 5 chemicals (formaldehyde, carbon monoxide, nitrogen dioxide, benzene, and naphthalene) to be regulated with high priority. These chemicals present a potential of dominating indoor exposures of at least significant fraction of the population, having common indoor sources, and known health effects. The group of second priority chemicals which are not considered to urgently require regulatory risk management actions specifically in indoor air included acetaldehyde, o-, p- and m-xylene, toluene and styrene.

A third group of additional chemicals of interest which were considered as requiring further research with regard to human exposure or dose response before recommendations could be made included ammonia, delta-limonene and alpha-pinene.

In the development of the framework for health based ventilation guidelines, the WHO indoor and outdoor air quality guidelines are considered among the criteria to be met, supplemented by the recommendations and risk management options of EU-INDEX especially for the chemicals not covered by the WHO guidelines.

2.3 Definition of “health-based ventilation rate” for a specific building

An important element of the framework for health based ventilation guidelines is the definition of the “*health-based ventilation rate*” for a specific building. This rate is defined when WHO air quality guidelines are met through a two-level sequential approach integrating source control measures and ventilation rates for a specific building.

A decision diagram for determining the proper “health-based ventilation rate” for a specific building was conceptualised and is shown in Figure 5. The diagram organizes the steps to be followed and conditions to be examined for implementing appropriate source control strategies at building design and operational stages and supplementing them by properly quantified health-based ventilation rates to guarantee that the indoor air quality meets the WHO air quality guidelines.

When the object of intervention is an existing building and/or if specific conditions have to be taken into consideration (e.g. the way the building is operated, the pollution load of the outdoor air, etc.), then appropriate ventilation levels have to be used to overcome the additional pollution load which may require higher health-based ventilation rates than the ‘base rate’.

The diagram in Figure 5 defines the three main air systems to be taken into consideration in the process of deriving the health-based ventilation rate as described in chapter 1.1. These are: (I) the ambient air, (II) the building or just one space in the building, and (III) the ventilation system. These three air systems should be considered to properly cope with any air pollution situation in a building. The definition of these systems is directly connected to the assumption that exposure levels indoors and, consequently, indoor air quality, are the result of the interaction between these systems.

The ambient air together with the building location, the air intake location and the building airtightness represent the 'outdoor air' system.

The building is an enclosure, considered as an air system itself (or several interconnected enclosures, meaning several air sub-systems) with some dynamics affecting the indoor air and its relationship with the outdoor air through the openings of the building's envelope.

Ventilation is defined as 'natural' when air enters the building through desired openings (doors, windows or others) or 'infiltration' when through undesired openings (cracks and crevices). The 'ventilation' system can be understood as the special device or equipment that, when needed, allows for better controlling the quantity and the quality of the air brought into the building.

According to the EnVIE project (de Oliveira-Fernandes et al., 2009), the first two systems are responsible for the source control in a given building or space, while from the HealthVent project's perspective, the ventilation system is seen as an auxiliary system that shall provide a service under specific requirements. It shall not be confused with the building system or considered as part of it.

Each of the three systems referred to above is related to air quality in specific ways, meaning that the control of pollution sources must be tackled differently at each stage, using different source control tools, as illustrated on the right-hand side in Figure 5.

The decision diagram starts with a first checkpoint to verify whether ambient air fulfils the WHO air quality guidelines. If this is not the case, then to avoid exposure to dangerous levels of air pollutants measures to clean the incoming to the building air must be then taken as discussed in Chapter 2.1. Attention must be paid over the temporal concentrations distribution for the specific building location as the WHO guidelines provide the respective exposure time span on short (minutes, hours, daily) or long term basis (annual). Consequently, the adoption of measures that are disproportionate to the status of ambient air pollution should be avoided.

If the levels of the WHO ambient air quality guidelines are met then there is no need for special air cleaning systems and the air can be directly delivered into the building either by natural or mechanical ventilation if the latter proves to be better under specific conditions. If due respect was given to the source control requirements in the building, then it should be expected that the "*base ventilation rate*" could be sufficient to satisfy the health-based requirements for its occupants (Chapter 2.4).

In case the WHO air quality guidelines are not met then the possibility of increasing the ventilation rate may be considered but only after having reviewing all potential source control interventions. If such increase of the ventilation rate will be finally deemed necessary then, the actual ventilation rate in L/s per person, it is advisable to express it in terms of a multiplying factor (greater than 1) of the "*base ventilation rate*".

As outdoor air quality is particularly difficult to tackle at city level, the definition of the “*health-based ventilation rate*” should be instrumental in stimulating the high priority that must be given to properly tackling air quality at city level. Consideration should still be given to aspects such as the building location (not near highways and roads with heavy traffic, industrial emissions, etc.), air intake location (e.g., adequately distanced from chimneys or air outlets), and even to building airtightness; they all affect the quality of the air indoors through the quality of the incoming outdoor air.

The building must also be appropriately designed and built considering its specific functions and operation practices indoors (for example, the different demands between office and residential buildings).

As the design phase of building represents an exercise of anticipating the future building’s operation and use, new ways of monitoring the building’s design process must be explored (AIRLOG project⁴). It will allow for the characterization of the materials regarding their power as emitting sources. Several national labelling schemes for construction materials and products are available in different EU countries. Efforts to develop a harmonization framework for their implementation have been undertaken by the European Commission’s Joint Research Centre in recent years (ECA 24, 2005; ECA 27, 2012; ECA 29, 2013).

⁴ AIRLOG project (a comprehensive state-of-the-art guidance for managing and diagnosing IAQ in buildings, and ultimately becoming a Good Practices Digital Guide in EU IAQ), <http://www.iaq-airlog.eu/>.

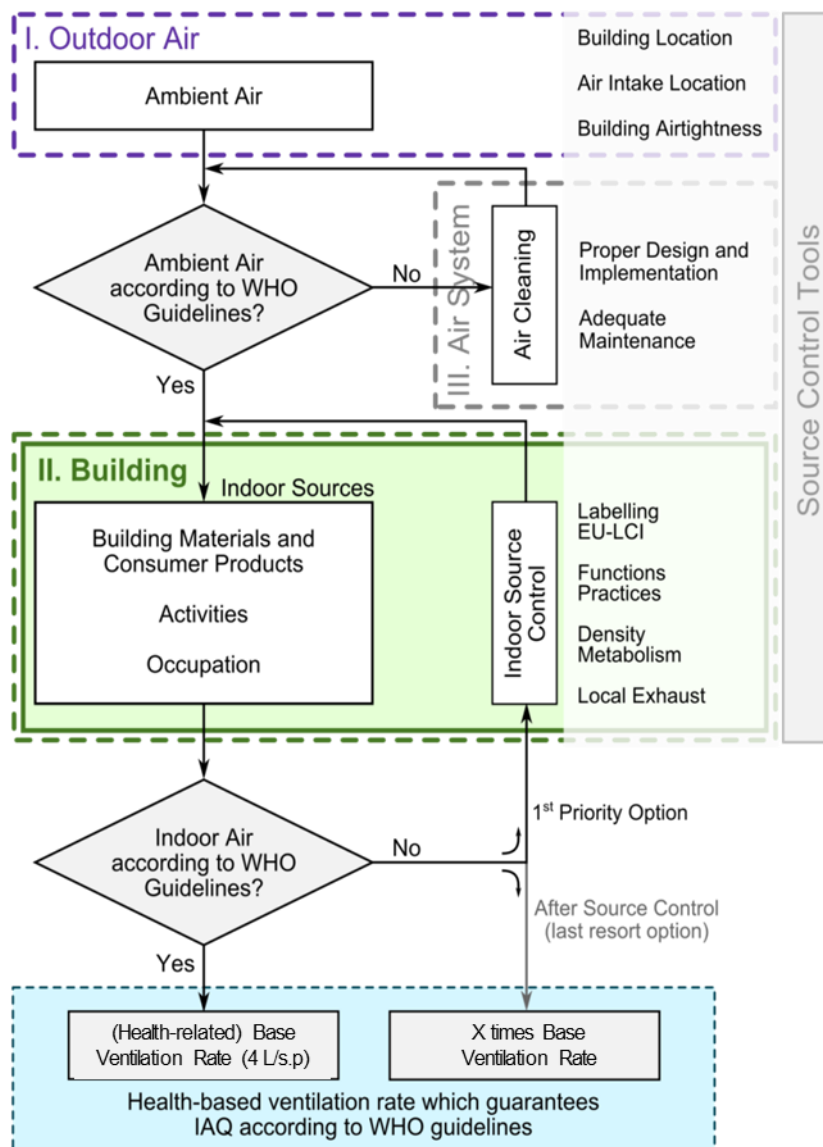

Figure 5. Decision diagram for deriving the adequate health-based ventilation rate for a specific building

Occupant density (expressed in terms of square meters per person/ occupant) and typical metabolic rate of people indoors (which is function of the type of activity and of indoor environmental parameters - temperature and humidity) impose different requirements on the building and ventilation needs which must also be taken into account. The local removal of humidity and pollution from sources such as, e.g., showers or natural gas stoves, will limit the dispersion of pollutants into the indoor air and improve the indoor air quality without a need for an unnecessary increase of ventilation levels to meet health requirements.

If the use of an air system is justified, then care must also be taken for its proper design and implementation as well as its adequate operation and maintenance, and compliance with the health-based ventilation requirements during its entire lifetime (Chapter 2.5). This is the only way to avoid health risks due to improper use or inadequate maintenance of an air system in buildings, situation which has been frequently encountered in the past and still continues to be a problem.

The health-based ventilation requirements must not be confused with and should be clearly separated from the current use of air as a 'heat' or 'cool' carrier for thermal comfort purposes.

2.4 Definition of health related "base ventilation rate"

The health-based ventilation rate can be quantified as a function of an appropriately defined health-related "*base ventilation rate*". The need of defining a base ventilation rate has already been acknowledged during the critical review of criteria and procedures for developing indoor air quality guidelines and standards performed by Seifert B. et al (1993). The base ventilation rate is intended to dilute and exhaust bio-effluents of the building occupants and it is a basic requirement that should always be satisfied.

The health-related "*base ventilation rate*" was established through a two-step approach..

Firstly, the scientific literature regarding epidemiological studies associating ventilation and health was scrutinized. The aim was to find the lowest ventilation rate at which no observed negative health effects were documented.

In the second step, the "*base ventilation rate*" was defined for the condition that the only source of indoor air pollution is bio-effluents emitted by humans, and by admitting that the concentration of other potential indoor pollutants are at levels of no concern for human health, i.e. meeting the requirements of the WHO indoor air quality guidelines. In the same step the impact of humidity and CO₂, the two main bio-effluents released by humans, can be modelled to devise the ventilation requirements needed to properly cope with these two types of indoor air pollution sources.

2.4.1 Health and ventilation - data from epidemiological studies

The scientific literature on the association between human health diseases and ventilation, as well as between indoor air exposures and ventilation was reviewed but only if connection to health problems was known. The purpose of this literature review was to define ventilation rates for which health risks are reduced (Carrer et al., 2012). The literature was collected by searching through the following databases: MEDLINE by National Library of Medicine, Toxnet and Web of Science. Additionally, the search was carried out through the proceedings of major conferences related to indoor air research such as 'Indoor Air' and 'Healthy Building' conference series. Included were papers published between beginning of 2001 until mid-2011.

The following categories of search profiles and search keywords were deemed important:

- *Indoor environments* – including non-industrial indoor settings, represented by all kinds of indoor environments: homes, offices, schools, day-care centres, dormitory rooms, etc., excluding hospitals.
- *Health* - considered broadly according to WHO definition (1948) which states that health is a state of complete physical, mental, and social well-being and not merely the absence of disease or infirmity. Health effects comprised thus diseases as well as end-

points describing comfort and wellness. The list of diseases included: allergy and asthma, respiratory and cardiovascular diseases, airborne respiratory infections and cancer. Sick building syndrome (SBS) symptoms called also building related (BR) symptoms were included as precursors of potential health problems and diseases. Perceived air quality was included and considered as an indicator of comfort. Performance, productivity and absenteeism were included as indicators of aggravated life quality and working conditions and being also a “warning signal” of a likely negative effect of exposures which can potentially lead to aggravated health conditions.

- *Ventilation* - referring both to the volume of air delivered to indoor space as well as the means by which the air was delivered (a system to transport the air). The typology of the ventilation systems considered is described in Appendix 2 of the present report. In addition, the maintenance of the systems was also considered.
- *Indoor related health risk exposure factors* – including different pollutants such as allergens, dampness, moulds, dust mites, bio-aerosols, bacteria, viruses, combustion particles, NO_x, PM, CO, VOCs, indoor chemistry products, mineral fibres, noise and microclimate parameters (temperature, humidity); radon was not included (as dealt with separately by the EU funded RADPAR project (RADPAR project, 2013)).

Many of the studies identified by the literature search lacked important details describing ventilation rates, their measurements (either with direct methods or using carbon dioxide as proxy) and/or exposures conditions. They also very poorly described actual exposures occurring in buildings where the studies were carried out; nearly all lacked measurements of pollutants which are potentially responsible for the examined effects. No information was given whether there were any special measures undertaken to reduce emission rates from building materials, furnishing and equipment, or generally whether any special source control measures were adopted; in many buildings where the studies were carried out, smoking was still possible. Nearly no study provided information on the quality of outdoor air and/or the air supplied by the ventilation system downstream the air handling unit implicitly assuming that outdoor air was clean.

Despite the above drawbacks the quality of studies described in 48 papers was adequate to form recommendations regarding ventilation and health; these recommendations were additionally examined against the results from the selected comprehensive reviews published on the topic (Wargocki et al., 2002; Seppänen et al., 2004; Fisk et al., 2009; Sundell et al., 2011; and Dimitroulopoulou et al., 2011).

The identified studies consistently showed that there is an association between ventilation and health which is depicted by the increased prevalence of SBS symptoms and allergic diseases and asthma symptoms. Additionally, they showed that there is a relationship between ventilation and increased short-term sick leave (probably due to increased risk for infection), acceptance of air quality (perceived air quality) and mental performance (office work by adults and schoolwork by children). Improper maintenance, design, and functioning of ventilation systems and in particular systems with air-conditioning (i.e. with the full control of cooling and humidification) were also shown to contribute to health problems indicated by the increased prevalence of SBS symptoms. None of the studies provided information on the

effects of ventilation rates and/or type of the ventilation system and its maintenance on the chronic health effects, such as respiratory and cardiovascular diseases or cancer.

There was no clear distinction whether ventilation supplied using natural means (i.e. natural ventilation system) or mechanical means (i.e. mechanical ventilation systems) is optimal for health purposes suggesting that ventilation rates that ascertain low exposures, rather than form of their delivery, are important for reducing health associated risks. This is valid only, if proper source control, design, functioning and maintenance of ventilation systems are implemented. Otherwise, ventilation systems contribute to the increased prevalence of SBS symptoms as indicated by the reviewed studies suggesting a need for separate guidelines only referring to this matter. Guidelines for design, operation and maintenance of ventilation systems are discussed in Chapter 2.6 of the present report.

Those studies judged as providing satisfactory information on health and ventilation (in which moreover the data were adequately analysed and reported) were used to investigate about the lowest levels of ventilation rates at which there no negative health effects are observed. It was surmised that the principles of primary prevention were applied to select these rates implying that prior to defining the ventilation rates to deal with the exposure levels all other potential measures to reduce exposures had been considered and executed (i.e. source control measures). A somehow similar approach was adopted in previous reviews made by Mendell (1993) and Seppänen et al. (1999). In recent reviews, a different approach was used to investigate about the association between ventilation and health, where maximum ventilation rates were defined, at which no negative health effects were observed in any of the reviewed studies (Wargocki et al., 2002; Sundell et al., 2011).

The reviewed papers indicated that:

- the lowest ventilation rates at which no elevated risk of asthma and allergic symptoms was observed was 7 L/s per person (data from Scandinavian homes) (Bornehag et al. 2005);
- the lowest ventilation rates at which no increase in the onset of SBS symptoms was identified was 8 L/s per person (in homes) (Engvall et al., 2005) and 9 L/s per person (in offices) (Erdmann et al., 2004).

These rates form at present the best available tentative estimates of the lowest rates at which no adverse health effect is observed. Coincidentally they are not different from the hygienic standard recommended by Pettenkofer in 1858 and neither much different from what is being prescribed by existing ventilation standards and guidelines (see Chapter 1.3).

2.4.2 Humidity, human bio-effluents and ventilation

Moisture produced by humans due to sweating is one of the important human bio-effluents. It influences the absolute and relative humidity levels indoors but is not used as proxy for ventilation due to varying levels of humidity in outdoor air.

Still under certain assumptions and conditions it can be examined whether the moisture produced due to human metabolic processes under normal activity levels indoors can increase relative humidity to levels which can be considered to potentially increase health related risks. In this context two aspects can be considered: elevated levels of relative

humidity increasing the risk for survival and proliferation of house dust mites and for the emergence and development of mould problems. To avoid house dust mites, it is assumed that an air humidity of 50% (reduction of the dust mites population) and of 60% (prevention of dust mites reproduction) should not be exceeded (Arlian, 2001; Harriman et al., 2001). To prevent mould growth the relative humidity on the inside of walls (in particular thermal bridges) should be below 80% (Harriman et al., 2001; Umweltbundesamt, 2002).

Assuming normal production of water (low activity such as resting or sitting and no cooking, showering or watering of houseplants as for these latter activities source control through local exhausts would be more effective than increased ventilation) ventilation rates which would keep the relative humidity indoors at the levels indicated above were determined through modelling. Three different building types (offices/schools, homes, and day-care centers) each with typical occupation patterns (8 h/d, 16 h/d, 24 h/d), and different room dimensions were examined. Winter conditions were considered in moderate to cold climates, with two conditions being particularly critical:

- Ambient conditions with temperature of -10°C and relative humidity of 100%, i.e. relatively dry but cold air potentially increasing the risk of high humidity levels at the inner surfaces of the building shell;
- Ambient conditions with temperature of $+10^{\circ}\text{C}$ and relative humidity of 75% and 85% promoting conditions that can increase the risk for house dust mites (HDMs) and mould.

Intermediate levels were modelled as well.

The modelling results suggest the following:

- To avoid risk for mould growth, the lowest outdoor air supply rate for the aforementioned ambient conditions ranges from 1 to 2 L/s per person. Only under particularly seldom conditions of high occupation and limited room dimension this rate can increase to 3 L/s per person;
- To avoid house dust mites at low ambient temperatures the lowest ventilation rates should typically be less than 2 L/s per person;
- With increasing ambient temperatures, the water content in the outdoor air also increases and the effectiveness of controlling humidity and thus HDMs proliferation indoors is reduced. Therefore, when outdoor relative humidity is below 75%, the ventilation rates of 1 to 3 L/s per person would be needed to avoid HDM reproduction, while as much as 6 L/s per person when outdoor relative humidity is 85%; When ambient relative humidity is greater than 85% to reduce the HDMs population would require ventilation rates from 8 to 13 L/s per person.

2.4.3 CO₂, human bio-effluents and ventilation

CO₂ is a proxy for human bio-effluents and its emission is a function of human metabolism and the density of occupation. The relationship between CO₂ and indoor air quality has not been strictly based on health/disease criteria but more on health/comfort (mainly related to smells

and on a subjective basis) and intellectual performance criteria. In this context CO₂ is considered as the *de facto* indicator for indoor air quality.

Typical CO₂ concentrations inside buildings vary from about 700 ppm to 2500 ppm. In this range, CO₂ is not thought to be directly responsible for any health-damaging effects (Seppänen et al., 1999). Health issues such as headaches, dizziness and nausea can be found at very-high concentrations of 30000 ppm, while levels of 15000 ppm are already associated with symptoms such as slightly affected breathing (Jones, 1999); 5,000 ppm is an occupational 8 hour average limit concentration. A recent paper shows that levels of 2500 ppm significantly affect decision-making performance while levels of 1000 ppm show a small but measurable effect on intellectual performance (Satish et al., 2012). However, according to these authors, standards that result in levels of 1500 ppm of indoor CO₂ concentration are conceivable. While high levels in the range from 2000 to 5000 ppm have been associated with decreased performance and attention capability, a causal link between CO₂ levels and those symptoms has not been proven (Coley et al., 2007; Shendell et al., 2004). CO₂ is used as a general indicator of the quality of indoor air or of the ventilation effectiveness. It is difficult to separate its effects from the ones associated with other indoor air pollutants such as volatile organic compounds (VOCs), particle matter (PM), carbon monoxide (CO) and others (Godish & Spengler, 1996; Sundell et al., 2011). Because of that role of CO₂ as a general indicator of indoor air quality (ASTM, 2012), there may be a tendency for standards and regulations concerning ventilation rates to push the maximum acceptable indoor CO₂ concentration levels to lower values, in an attempt to solve issues that may instead be associated with an inefficient control of various pollution sources (e.g. EN 15251, 2007).

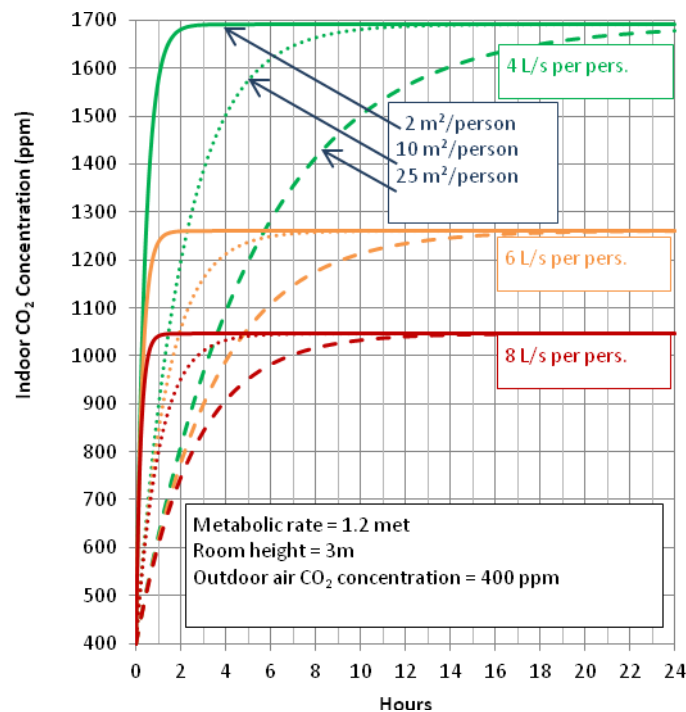

Figure 6. CO₂ accumulation indoors as function of time, occupation density and ventilation rate

Using mass-balance equation, CO₂ concentration was modelled depending on ventilation rate, metabolic rate and occupation density. Increasing ventilation rate, results in slower accumulation of CO₂ indoors and a lower equilibrium concentration. These become around 1700 ppm, 1250 ppm or 1050 ppm when using 4, 6 or 8 L/s per person, respectively (Figure 6).

CO₂ generation indoors is also directly correlated to the metabolic activity of occupants. The typical value for the physical activity of people in residences, schools or offices ranges from 0.8 to 1.2 met. Figure 7 shows the relationship between the equilibrium concentration and the metabolic rate at different ventilation rates.

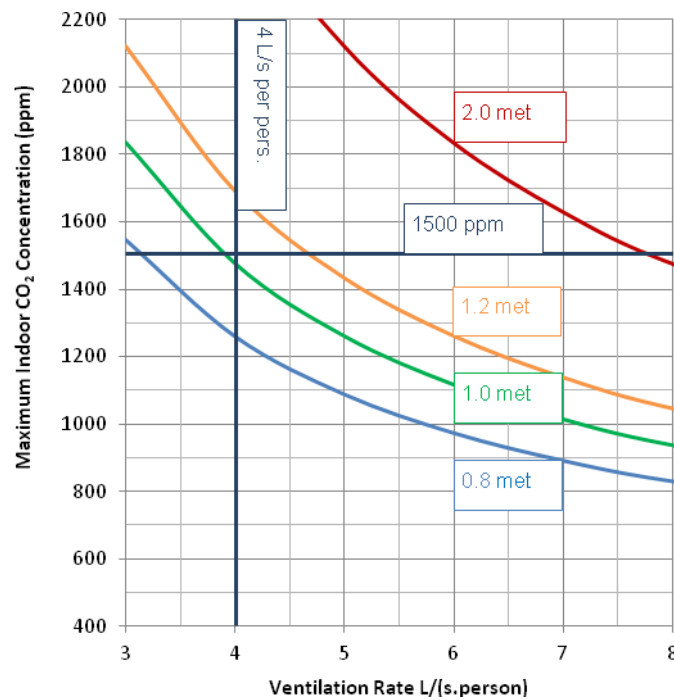

Figure 7. Maximum equilibrium CO₂ concentrations indoors as function of metabolic and ventilation rate

The building area per person in residential buildings is usually higher than 25 m² per person, around 7 to 15 m² per person in offices and 2 to 4 m² per person in schools. Lower occupation densities and/or higher internal volumes result in a slower rate of CO₂ concentration increase. This is shown in Figures 8 to 10 assuming certain occupation periods typical for different types of buildings. .

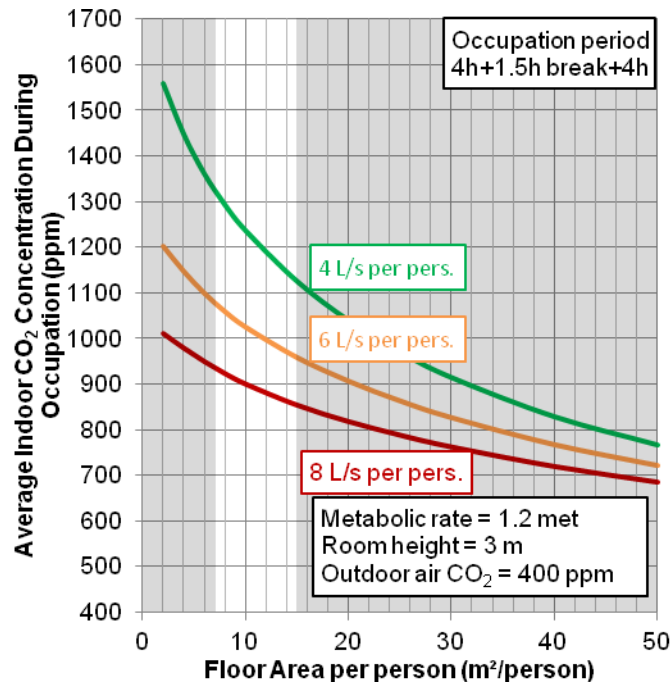

Figure 8. Average CO₂ concentrations indoors as a function of ventilation rate, occupation density and occupation period for the cases of 12 hours of occupation - unshaded areas correspond to typical occupation densities for office buildings.

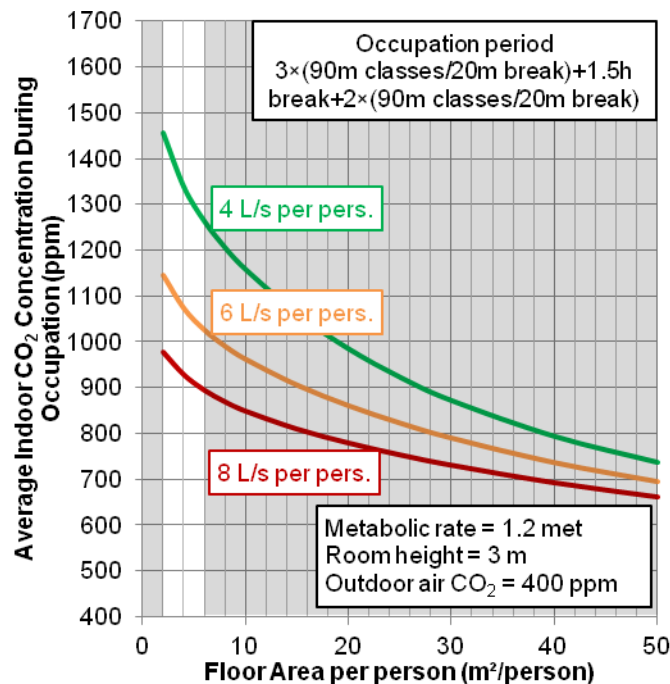

Figure 9. Average CO₂ concentrations indoors as a function of ventilation rate, occupation density and occupation period for the cases of five 1.5 hour class periods with 20 minutes breaks and 1.5 hours lunch break - unshaded areas correspond to typical occupation densities for school buildings

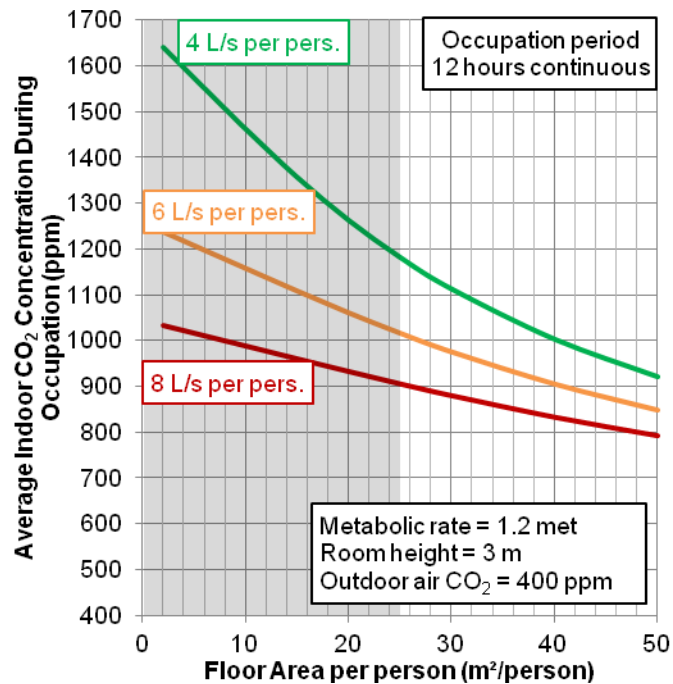

Figure 10. Average CO₂ concentrations indoors as a function of ventilation rate, occupation density and occupation period for the cases of 12 hours of occupation - unshaded areas correspond to typical occupation densities for residential buildings

2.4.4 Selection of the base ventilation rate

The “*base ventilation rate*” is set at 4 L/s per person taking into account the outcome of the literature review of epidemiological studies on ventilation and health and modelling of exposure to human bio-effluents using CO₂ and moisture as decision criteria. The rationale is provided below.

The lowest ventilation rates which were defined based on epidemiological evidence are not related to actual exposures and/or specific pollutants. It is thus very difficult to generalize their use for every typology of buildings because the indoor environments can differ as regards their pollution loads. Building materials, furnishings, unvented combustion and other processes and equipment, besides people and their activities, emit substances into the indoor air. Emissions vary greatly by contaminant species and among buildings as well as temporally and spatially within buildings; moreover there are complex relationships among contaminant levels, ventilation rates, and building-related health effects. Consequently, these rates cannot be used as guideline values (that would be operational in all kinds of indoor environments) to reduce health risks. A different approach must be then devised which would on one hand allow for proper control of exposures and on the other hand ensure that the ventilation is the ultimate measure to control exposures after all other measures are exploited (by reducing the indoor pollution sources through e.g. proper materials and products labelling, and outdoor pollution sources through e.g. proper management actions enforced by legislative actions). The only exposures which can potentially be uniformly defined and tackled upon are the

emissions from humans (i.e. human bio-effluents). However, none of the studies reviewed provide clear relationship between health effects and exposure to human bio-effluents.

Consequently, the modeling showed that even very low ventilation rates, below 3 L/s per person and lower will be quite effective to remove moisture produced by humans and reduce the risk of mould growth. This is consistent with the recommendations of the WHO Guidelines for Indoor Air Quality: Dampness and Mould (WHO, 2009). Higher rates would be needed to control HDMs but considering that there are other effective remedial actions to reduce the population of HDMs it may be unwise to recommend increasing ventilation rates to reduce the moisture indoors produced by human metabolic processes to combat HDMs. To this end it should also be noticed that ventilation can only be effective during certain period of the year and only in regions with fairly cold winters to effectively reduce moisture to avoid HDMs.

Although moisture modelling suggests 3 L/s per person to reduce the risk for mould, 4 L/s per person is selected as the base rate. This decision is made following CO₂ modelling and also to create some additional level of protection. For the conditions of metabolic rate, activities and occupation densities typically found in residences, offices, schools and other comparable buildings, the ventilation rate of 4 L/s per person assures that average CO₂ concentrations stay below the 1500 ppm level. If more demanding conditions are found in the building, then some extra ventilation might be needed to deal with the extra metabolic activity (more intense CO₂ generation) and bio-effluents release. For comparison to the existing standards, the ASHRAE Standard 62 (2013) points towards a maximum recommended level of CO₂ at 1000 ppm as an indicator of good indoor air quality. Regulations in Germany consider the range of 1000 to 2000 as “high” (but acceptable) for CO₂ concentration, while Japan and the United Kingdom accept the limit at 1500 ppm (Hasegawa, et al., 2012). The European standard EN 15251 (2007) allows up to 1200 ppm of CO₂ depending on the building class.

The base rate is only applicable if human bio-effluents are the only pollutants to be handled by ventilation and all other pollutants, from both indoor and outdoor sources, being kept at levels which do not increase health risks, i.e., they meet the limit values set by the WHO Air Quality Guidelines.

Although purely theoretical the chosen scenario for selecting the base rate follows the concept of precautionary principle. It is also quite natural, intuitive and conceivable. Thus, it is creating a true benchmark and reference point for defining ventilation rates in non-industrial settings. It also promotes the actions related to control and reduction of pollution sources both indoors and outdoors. In reality, no values lower than this level can be admitted thereby and stating a reference that can only be exceeded when defining the appropriate ventilation rate for each case.

The proposed base ventilation rate of 4 L/s per person is already acknowledged by several national and international standards (EN, USA, Japan, Nordic European countries, etc.) (e.g. in Sundell J, 1982: Guidelines for Nordic building regulations regarding indoor air quality). This rate corresponds to the minimum ventilation rate in the EN 15251 (2007) for assessing the air quality in spaces polluted only by human bio-effluents.

The selection of the base ventilation rate at 4 L/s per person is not necessarily compatible with most of the conditions encountered in actual buildings. However, its purpose is to create a limit value that shall inspire further actions to promote and maintain sustainably good indoor air quality in buildings.

2.5 Ventilation system type

The present report does not make any specific recommendations as regards the selection of the type of the system to use for supplying air for ventilation purposes that supports the health-based ventilation guidelines. Ventilation should ascertain control of exposures to indoor air pollutants regardless of whether supplied using natural or mechanical means, or both. The quality of air delivered cannot affect the exposures indoors, independently how supplied, so that the risk for health are not elevated.

Ventilation systems may not be necessarily needed and, far from that, it will not be advisable to generalize their use to all EU countries and to all typologies of buildings. Their use has to be justified not only by each building owner or designer but, before that, by each standard and regulation or practice code. In large areas of EU it may be unnecessary or dispensable, in particular for housing, but also in other building types during large periods of the year. It is a fact that natural ventilation is rather variable over time and uncertain in what concerns the guarantee the required ventilation rates. However, it is also true, that there are many regions in the EU where citizens have a long tradition of taking advantage of a great permeability of their houses and other buildings in general to the ambient air through windows and doors open for several hours of the day and for long periods of the year. Yet, the ventilation level being an exposure control strategy may not need to be constant over the entire time of the building's occupation. So, the practice of using ventilation systems (while meeting the high demands of low energy consumption, and in a quite challenging changing context concerning the sustainable approach of the cities' governance) must be tackled at the level of each location to the dimension of the city or of the region before going down to the dimension of the single building.

The building may have other needs than the strict fulfilment of the indoor air quality parameters such as the adjustment of the temperatures indoors to levels of comfort despite the climatic conditions outdoors. In practice, some Member States already use heat recovery systems associated to mechanical ventilation to reduce the heat load implicit to the incoming ambient air. That may make sense given the difference of temperature between indoors and outdoors in some European regions, ensuring that the health-based ventilation does not disturb the pre-established comfort conditions for indoor environments. However, that must be seen differently from increasing the ventilation rate to use the air as a heat carrier. As a matter of fact it has become current practice with air conditioning to use air for the purpose of heating or cooling the space despite the fact that air is one of the lowest low heat capacity fluids and hence not the most rational option for that purpose.

That calls for a more intelligent approach to enable separating the essential function of bringing the amount of fresh air necessary to assure the health-based ventilation rate into the building from the need for other flow rates, eventually higher, to fulfil desiderata such as for heating or cooling the spaces. Those considerations surely deserve some clarification in order to state clear priorities on the identification of the steps regarding an efficient and balanced attainment of health and comfort conditions and energy management in the building stock.

2.6 Guidelines for design, operation and maintenance of ventilation systems

Scientific and technical literature shows that design, operation and maintenance of systems providing the air for ventilation (particularly mechanical ventilation systems with humidity control and cooling) have not always been adequate. This resulted in systems becoming strong source of pollution that caused elevated exposures and consequently increased health risks [Mendell, 1993; Sieber et al., 1996; Seppänen and Fisk 2002; Mendell et al., 2003; Wargocki et al., 2002]. The list of reported problems is long. The most common ones include: insufficient air inlet size with a loss of pressure being too high; missing condensate drain for the in-ground air heat exchanger and/or ventilation device; no insulation of ducts conveying cold air (condensate is formed in pipes);, bad maintenance of filters; low class of filtration; inaccessible and dirty filters seldom changed for new ones; missing sound attenuators; improper cross-sections of ducts causing the air velocity to be too high or too low; inappropriate material of pipes (flexible tubes); improper location of main air intakes and exhausts; too short distances between main intakes and exhausts; supply and exhaust air openings almost always prone for short circuit; partially or fully blocked (covered) air terminals.

These problems are irrespective of the building type. They are not present because ventilation of buildings is a new technology; it has been a standard practice for many decades. It is obvious that the ventilation system (air system III, Figure 5) has not been receiving the attention in technical and legal terms that it deserves. The performance of the ventilation system (being complementary to the building system) must be evaluated independently of the 'system building' (system II) itself. Moreover, the providers must guarantee the quality of the air delivered inside the buildings at any time according to pre-agreed conditions which may deserve being stated in standards.

One of the reasons for the problems related with the operation and design of the systems used for supplying air for ventilation purposes may due to: lack of knowledge and experience among architects, designers and contractors; lack of proper operation manuals and sufficient instructions; improper and/or lack of balancing and regulation of the systems according to actual (but not designed) needs and demands. It is obvious that the practice, mainly initiated in USA, of using air for active climatisation (air conditioning) ended up by making those systems too much complex and therefore much more susceptible to be a cause of dysfunction..

Besides, at present, there are not basically any regular inspections mandated which require examination of whether the systems operate as designed or according to the current demands, and whether they are maintained properly (e.g., clean).

The mechanical systems used for supplying air for ventilation must have high and guaranteed performance as regards the quality of air provided from the beginning of their operation through their entire lifetime. This requirement should be assured by the providers of the systems and verified at the beginning of their operation and checked out regularly throughout their lifetime.

Although the current guidelines do discuss the effects of exposure to air pollutants, it should be emphasized that many systems used for supplying air for ventilation purposes are sources

of noise. This results in either blocking the air supply or simply shutting down the system. Consequently, the systems operate at flows lower than nominal which may result in increased exposures and associated health risks. Similarly, the same can also occur if the systems deliver air with too high velocities and increase risk for drafts. Proper design and operation is thereby crucial for reaching the goals outlined by the health-based ventilation guidelines concept.

Many European standards and technical reports on ventilation present some requirements regarding design, operation and maintenance of ventilation systems (see Chapter 1.3 and Appendix 3). Mandatory inspections of ventilation systems exist in Sweden and Portugal since 1991 and 2006, respectively (Boverket, 1991; Portugal, 2006). The inspections are performed by quality experts at regular intervals and are varying depending on the type of system and building. Various types of systems require different qualifications of the inspector. The goal of the inspections in Sweden is to investigate whether the ventilation system performs as designed. Any faults need corrective measures otherwise penalties are issued. Although reasonably operational they do not control whether the system meets actual requirements at the time of inspection, only whether it meets the design parameters. Furthermore, not all buildings are part of the protocol and the results are not part of a central register. Local municipal authorities, who often own the buildings, are in charge of inspections. In Portugal, the inspections include control of number of parameters related to indoor air quality and ventilation rates. Those inspections are performed together with the assessment of the energy efficiency of the heating/cooling functions of the climatisation system.

Table 5 – *Guidelines for design, operation and maintenance of systems used to supply air for ventilation (Air system III of Figure 5)*

GUIDELINES FOR DESIGN, OPERATION AND MAINTENANCE OF SYSTEMS USED TO SUPPLY AIR FOR VENTILATION (1/2)

- The air supplied by any system used for ventilation should comply with the principles of the health-based ventilation guidelines. The systems should meet these requirements from the initiation throughout the entire life-time of the building.
- Ventilation systems should be decoupled from heating/cooling systems. Low-emitting, certified and durable materials should be used in any system used for ventilation. Emission from fibrous materials should be reduced to a minimum.
- Systems used for ventilation should be kept clean for the whole building lifetime. They should be cleaned at regular intervals using certified products for wet and dry cleaning which do not elevate exposures of relevance to the health-based ventilation guidelines.
- The performance of mechanical ventilation systems should be verified at the commissioning phase of a building and shall be guaranteed by the deliverers throughout the entire lifetime of the building and of the systems.
- Condensation in the systems used for ventilation should be minimized to avoid microbial growth. Systems should be properly drained and kept dry. Outdoor air intakes should prevent against rain and snow entrainment. Systems creating risk of condensation and moisture should be separated from the systems supplying the air for health-based ventilation purposes.
- Air cleaning producing ozone in the systems used for ventilation should be avoided.
- The rate of ventilation should cope with the actual needs and demands and should not only be based on the design parameters. The rate should be determined following the principles for determining health-based ventilation.
- In case a mechanical system is used for ventilation, there should be contingency plan for ensuring ventilation (e.g., by opening the windows or other measures) in case of the system's failure. This also applies to blocking and shutting down the systems by the users and operators.
- All outdoor air intakes including openings for natural ventilation should be located to minimize the direct entrainment of pollutants from nearby sources.

GUIDELINES FOR DESIGN, OPERATION AND MAINTENANCE OF SYSTEMS USED TO SUPPLY AIR FOR VENTILATION (2/2)

- Ventilation air should be properly distributed within the space that it is serving.
- The systems used for ventilation shall not become the source of nuisance and/or annoyance due to noise, vibration or draft at any time from the commissioning time throughout their entire lifetime.
- The systems used for ventilation should be regularly maintained and inspected during normal operation. The inspections should include at minimum the same aspects as during commissioning and additionally examination of cleanliness, loading of filters and the need for re-balancing in case of changed demands. The inspections can be integrated with other compulsory audits, e.g., such as those specified by the Energy Performance of Buildings Directive (energy auditing and auditing of air-conditioning systems) and/or integrated with the regular inspections performed by chimney sweepers. Those obligations shall become exclusive responsibility of the suppliers of the systems.
- Systems used for ventilation should be designed, operated and maintained by qualified staff. Design should address the possibility for regular maintenance and override. Continuous education programmes should be implemented for designers, consultants and facility managers which besides technical matters should also address the connection between ventilation and exposures within the health-based ventilation perspective and framework. Operation instructions should always be provided.

Despite some loose requirements in the standards and codes and mandatory inspections in Sweden and Portugal, there is no single document that brings all requirements together in form of a protocol. Such protocol would provide instructions about the actions that need to be taken to ensure that the systems used to supply ventilation do operate according to what they are designed for and are supposed to deliver without increasing exposure to pollutants and associated health risks. Consequently, an attempt was made to conceive a coherent set of qualitative guidelines which would support the principles of the health-based guidelines framework illustrated in the decision chart of Figure 5. These guidelines are presented in Table 5 and identify and specify the necessary actions to ensure that the systems supplying air for ventilation are properly designed, operated and maintained from the initial phase and during their entire lifetime. These guidelines clarify the general principle of air hygiene, i.e. avoiding exposure to pollutants that might be harmful to health. They have been devised based on practical experience and the “real-world” ventilation related problems reported in the scientific and technical literature. They should be considered as a component of the holistic health risk management framework of indoor air. Because of the continuous development of systems used for ventilation from a technical point of view they need regular review and where appropriate updating.

These guidelines have been developed having in mind mechanical ventilation systems. They do however present universal requirements for any system used to supply air for ventilation. Appendix 2 of the present report describes the typology of different systems used for ventilation that should be respected by any systems: new systems, systems undergoing retrofit and renovation and existing systems under operation.

Together with the Swedish and Portuguese mandatory inspections and the requirements that are already included in the European standards, the guidelines presented in this report can form the basis for developing a future pan-European mandatory protocol for inspection of systems used for ventilation.

3. GUIDELINES' IMPLEMENTATION, IMPACTS, POLICY RECOMMENDATIONS AND FUTURE RESEARCH NEEDS

3.1 Guidelines implementation

3.1.1 From the ventilation panacea to health-based ventilation

Ventilation for long time has been very much seen as a panacea for health and comfort related problems in both occupational and non-occupational environments basically acting for diluting the indoor air pollutants, either gaseous or particulate matter. Much later on, a specific burden was put on ventilation when blown air started being used as the main carrier for air conditioning through which, by definition, it is meant to be able to control the highest (cooling) and the lowest (heating) temperature as well as the relative humidity of indoor air.

This approach has been source of several drawbacks at least during the last 50 years. Among those, three drawbacks have been identified as the most relevant:

- The unsuccessful handling of the thermal comfort issue, which was never solved as it was defined for quite strict common conditions of clothing and activities of the occupants while admitting a certain percentage of dissatisfied people (ASHRAE 62/2001; EN 15251/2007) and without any requirements for the occupants;
- The question of the high energy use associated with climatisation, which has proven irrational by using air as the energy carrier, one substance among those with the lowest heat capacity;
- The issue of the indoor air quality that has been shown (see AIRLESS project) to be hardly managed if complex air conditioning systems are used which are not necessarily properly designed, operated and maintained (which due to their complexity in any case are very difficult to keep fine-tuned to the initial conditions at commissioning time).

Three important reasons led to revisiting the ventilation issue from a practical point of view and in line with advancements of the practice, of course but, more importantly, on the advancement of knowledge. The three reasons are:

- a. The emergence in 2004 of the adaptive comfort concept and standards (ASHRAE 55/2004, EN15251) that specified its use in non-air conditioned buildings but could be generalized provided that some proactivity on the occupants' side concerning their own comfort conditions not interfering with their neighbours' conditions could be undertaken;
- b. The understanding that the two functions, 'ventilation' and 'heating/cooling', must be decoupled as it was the current practice in Europe in the 60s and 70s, but without underestimating the potential role of the building fabrics and its design and operation to attenuate the heating and cooling needs in line with the climatic peculiarities of the building's specific location;
- c. The definition of the ventilation concept not on health-based criteria but for many years settled on a subjective basis and controversial thermal comfort criteria.

In such a context, it appears promising and timely to elaborate in detail a more clear, concise and practical foundation of the ventilation issue and its role on the control the air quality and humidity and temperature conditions for any indoor environment strictly on health-based criteria. Consequently, the needs and the entire management of the ventilation issue should be readjusted concerning its purposes and the expected impact of its implementation across various typologies of buildings and equipment and conditions of use, control and optimization. And this on the top of monitoring and assessing the performance via IAQ auditing procedures integrated into the energy audits.

3.1.2 Integration of IAQ in energy audits, monitoring and performance

Buildings are clusters of spaces with the most diverse specifications regarding the parameters that define the indoor environment and its air quality conditions.

Indoor air quality concerns quite a number of issues (i.e., outdoor air, ways of the incoming air, type of materials used in the construction and in cladding, decoration and furniture products used and activities undertaken indoors and the ways the building is managed and operated) which introduce many variables that one can only hardly cope with effectively and efficiently.

The aforementioned necessitates a holistic approach to address the IAQ related “chain of events” (i.e. indoor air pollution from causes and sources to exposures and health effects). Such approach has been elaborated by the EU funded EnVIE project (de Oliveira Fernandes, 2009) that put emphasis on source control as the prime strategy and ventilation as the complementary means to manage and achieve indoor air quality in buildings accounting for the presence of various pollution sources.

Pollutant control is often most effective and easier to implement at source level. The selection of “clean” materials and consumer products through “ecological” labels is another example of source control. In Europe, at national level, there are a number of initiatives to produce and label low emission materials including mandatory schemes in Germany, France and lately in Belgium. Existing national and industry based labelling schemes are being developed to fit the requirements of the Construction Products Regulation (CPR, 2011) and also to address specific local and market needs. Recently the EC’s Joint Research Centre has developed two harmonisation frameworks concerning the labelling and the health-based evaluation of chemical emissions from construction products (ECA 29, 2013; ECA 27, 2012). These are expected to trigger and lead to a convergence of existing methods, hence providing harmonised requirements and reducing the cost for testing, evaluating and getting approval of construction products under the various mandatory and voluntary schemes.

Source control is expected to take place in the future increasingly at the design stage with a pre-evaluation of pollution load as proposed by the HealthVent project and detailed in previous chapters of the present report.

Existing IAQ related policies at EU and national levels need to foresee the inclusion of monitoring and auditing processes for:

- a. Testing whether they are successfully complying with the pre-established IAQ targets in various typologies of buildings;

- b. Identifying the needs for intervention plan, or to steer the foundation of new policies and standardisation work if the objectives are not achieved.
- c. Assessing the performance of ventilation and of air conditioning systems and periodically monitoring the status of IAQ at post-occupational conditions of a building.

These are somehow implicitly addressed in the Construction Products Regulation (CPR, 2011) and only partially required by the Energy Performance Buildings Directive (EPBD, 2010). However, none explicitly requires a monitoring and reporting plan for IAQ parameters except for comfort strictly speaking parameters in the latter Directive. Consequently, no European systematic indoor air monitoring system is actually running following a harmonized process. Nevertheless, several indoor air monitoring studies in the EU have been performed in the framework of EU funded research projects (e.g., IAQ audit, EXPOLIS, PEOPLE, THADE, AIRMEX, SINPHONIE, OFFICAIR, etc.) or in the context of national monitoring programs in the Member States (e.g. the German Environmental Survey (GerES), French Indoor Air Quality Observatory (Observatoire de la qualité de l'air intérieur), the FLIES study in Belgium (Flanders Indoor Air Exposure Survey), etc.).

Harmonisation efforts have been undertaken in the context of the European Commission's sponsored PILOT INDOOR-MONIT project (Kephalopoulos et al., 2013) in which a harmonisation framework on indoor air quality monitoring requirements across five alternative indoor air quality objective methodologies has been elaborated.

Standardized procedures and assessment protocols for IAQ have been described and adopted at national level in Portugal (Portugal, 2006) (integrated into the legislation on Building Performance Certification since 2006) and more recently also in France in association with legislation on IAQ in schools (France, 2012) but not yet implemented on a systematic and European wide basis. Based on current state-of-the-art of IAQ monitoring and auditing practices within the EU, an IAQ audit platform consisting of 6 different IAQ audit objectives that integrate 5 main levels of action was proposed by the EU funded AIRLOG project (AIRLOG, 2014). Each of the action levels is connected to several information databases, based on the three already mentioned main structural modules: location of the building; the building itself and the building systems (air, thermal and water). The IAQ auditing process is complex, quite often dealing with low concentrations in a very wide spectrum of conditions. This implies the need for a clear definition of the objectives and proper characterization of the mission and limits of the IAQ auditing process while guaranteeing the quality and comparability of the results. Thus, in the process of designing the AIRLOG platform efforts focused in establishing the taxonomy of different audit typologies which are allowing flexibility for future integration of other relevant IAQ audit processes at EU level. Emphasis was put to the audit at the design stage which requires the support of appropriate simulation tools to cope with a number of interlinked and dynamically evolving issues (e.g. scrutiny and accounting of all emissions indoors, adsorption/desorption processes and chemical reactions indoors, occupancy load, ventilation systems and practices, etc.).

In conclusion:

- a) The IAQ issue must be properly tackled upon in all building related directives (and their recasts) dealing with building parameters: starting upstream, by their location and design, their construction materials and components incorporated and the furniture and activities conducted inside them, till their operation which may be or facilitate the emergence of IAQ sources. That shall be especially the case of EU

Directive on the Energy Performance of Buildings (EPBD), which must control the performance of all energy systems while managing the avoidance of potential pitfalls of energy efficiency requirements in existing, new and renovated buildings which may negatively impact on human health. In this context, further effort has to be devoted concerning the integration of a harmonised assessment of the IAQ parameters (auditing) and the reporting and communication of the auditing results.

- b) Existing mandatory and voluntary labelling systems of materials and building products in the EU Member States must be harmonized to fulfil the essential requirements of CPR and especially its 3rd requirement (Hygiene, health and the environment) including IAQ requirements. This process has made great progress in the EU on initiative of some Member States such as Finland, Germany, Denmark, France and recently Belgium.
- c) Harmonisation frameworks for products labelling and health-based evaluation of their chemical emissions as well as tools and protocols for monitoring and auditing of indoor air quality in European buildings have been recently developed on European Commission's initiatives and within EU funded projects and are ready for their up-taking by the various building related policies at EU level. Their implementation via a comprehensive and holistic approach which properly considers source based strategies and ventilation practices (such as that those proposed by EnVIE and HealthVent) and integration of IAQ audit typologies (as those elaborated by AIRLOG) would greatly help meeting the challenging EU energy efficiency targets while reducing the risks associated to human exposure in buildings.

3.1.3 Performance-based evaluation of ventilation

Ventilation aims at providing clean air inside occupied indoor spaces in order to ensure healthy and comfortable conditions. Thus, the ventilation strategy should be considered in relation to a strict control of indoor pollution sources (including the incoming ambient air), humidity and any human bio- effluents and the allocation of fresh air to the occupied zone in relation with the density of occupants.

However, in reality, most of existing ventilation regulations is focusing on a prescription of permanent or global air flow rate. This rate does not really consider on the one hand the diversity of the pollutant sources in the building and on the other hand the real exposure of the occupants. For this reason the current way of expressing the air ventilation rate as air changes per hour (ACH) needs to be replaced by a parameter such as litres per second per person which accounts for the occupants of the building/room. The variation of standards in terms of air changes per hour in the EU can vary from 0.5 to 0,98 but that does not take into account the variability of the available surface space per occupant (for example 20 m²/person in Romania and 50 m²/person in Denmark). Moreover, inside the buildings and especially for housing the air is not necessarily continuously renovated in all rooms of the house. From a health point of view, given the people mobility within the house and the time spent in each room, it allows for handling the ventilation regime flexibly to guarantee safe exposure levels. Of course if the only way to achieve ventilation is by natural forces these considerations

become more problematic to implement while the uncertainties can be somehow compensated with some strategically located exhaust mechanism in the building.

When mechanical ventilation is necessary, to improve the ventilation efficiency in buildings, the controlled zone should be specifically defined. If one goal of the ventilation process is to decrease the exposure of the occupants to pollutants and improve their comfort, it should be also variable in time and linked to the presence of the persons. For example, in office buildings, often, the room itself (office, meeting rooms, etc.), defines the controlled zone and the ventilation can be modulated according to the occupancy level.

Nowadays, control strategies of ventilation systems have been developed thanks to the development on innovative sensors control and mechanical ventilation systems. They can use as indicators, room's occupancy level, presence/absence of people, humidity, CO₂ or levels of a given pollutant directly linked to a specific activity. Even if none of these indicators can pretend to represent alone the indoor air quality or the overall comfort conditions of the occupants, they can certainly be used for improving the performance of the ventilation strategies.

Concluding, the guidelines presented in chapter 2 are not technical guidelines and need several steps before they can be implemented in practice. The following general actions are needed:

- Standards, Directives and regulations should be adjusted to follow the proposed concept and approaches to achieve health-based ventilation rates, namely:
 - ✓ Give priority to source control by checking the building's location and design and the construction materials and products employed in the building
 - ✓ Proceed with the harmonization of labelling processes related to construction materials, components and consumer products that are used in buildings
 - ✓ Incorporate of the source control principle in all standards and regulations regarding potential indoor pollution sources, namely those related with heating/cooling energy systems, combustion processes, etc.
 - ✓ Harmonize the auditing procedures according to the typology of the issues to be tackled in conditions of replication and accuracy to be recognized by third parties
- New algorithms and designing routines must be produced and adopted by standards and regulations in order to facilitate the implementation of the health-based ventilation guidelines' concept and recommendations
- Buildings' design and construction principles should include requirements to use certified and labelled low-emitting building materials, household products and appliances in new constructions as well as in retrofitted and renovated buildings and for the entire building's lifetime.
- Harmonized audit procedures should be established to examine compliance of the air quality inside the building spaces against the WHO air quality guidelines and against the requirements of the health-based ventilation guidelines framework.

3.2 Impacts

3.2.1 Impact on energy

Energy use in buildings is a critical issue. In principle, all energy uses in buildings have some potential to be reduced or avoided, being these two options significantly different. They are also different from the economic point of view in the sense that the reduction does not prevent some eventual rebound effect while the avoidance of energy needs will directly impact on supply systems which would have to be planned for less service; this would result in a reduction of financial resources devoted to uses that the society does not actually need and could thus be diverted to other purposes.

Energy used in buildings can be structured by different uses or by different final energy vectors following a rational principle of diversity of vectors. Amongst those uses there are heating and cooling and very often also mechanical ventilation which is usually associated indiscriminately to both of those services.

The first think that is necessary to clarify is whether there is a need to use mechanical ventilation or not. The issue of the natural ventilation has been addressed abundantly in the literature. The challenge nowadays, and in the context of this report, is to clarify the borders between natural ventilation that can provide the proper fresh air for a given building and the existing conditions to fulfil other functions such as heating/cooling. If the ambient air is not fulfilling the WHO IAQ Guidelines there is no other alternative than the filtering/washing of the incoming air which will become necessary. Here, what is relevant is that if natural ventilation is compatible with the health related IAQ requirements the energy for mechanical ventilation (i.e. needed to move the air) will be avoided. And subsequently the decoupling of heating and cooling associated with the ventilation will become obvious as those eventual comfort functions will have to be fulfilled by alternative ways in the building or in the space itself.

If there is mechanical ventilation, the demand for heating and/or cooling of a space through the use of heated or cooled fresh air entails the need to adjust totally or partially the temperature of the incoming air. There are three potential components of the demand for energy associated with mechanical ventilation: *i.* the energy needed to move the air itself; *ii.* the energy needed to compensate the heat loss/gain associated with the introduction of outdoor air and; *iii.* the energy needed to compensate the heat losses though the envelope.

In the context of this report, it should be clear that if there must be a ventilation need based on health criteria the value of the ventilation rate to establish should account for the occupants.. If, for example, an apartment for two people has 50 m² per person and is 3 m high, 4 L/s per person represents about 0.2 ACH which is a figure entirely uncommon and far from being considered as acceptable. If this is the case, then the aforementioned cases *i.* and *ii.* are of minor importance and the case just worthy of a footnote.

The reliance on natural ventilation, as opposed to the use of mechanical systems for ventilation, presents a number of challenges of which the most prominent are the difficulty in controlling the flow-rate of the incoming air, the inability of cleaning the air (if needed) and the impossibility of resorting to heat-recovery. These issues, however, must be counterweighted against the fact that mechanical systems require careful and regular

inspections and maintenance procedures. These procedures impose extra financial and energy burdens, not only upon acquisition and installation of the systems but also through the required use of energy to drive the ventilation fans and other mechanical systems. In some circumstances, this added energy expenditure can become higher than the reductions on heat losses through ventilation. Care should also be taken when mechanical systems are in place and used for heating and cooling the spaces while using air as the thermal transport medium. Due to the very low heat capacity of air, the ventilation rates needed to supply or remove the required amount of heat from the spaces might be much higher than those needed just for the function of health-based ventilation. This has adverse impacts on comfort and energy, and even though the impact of increasing ventilation rate for thermal purposes can be reduced by the use of recirculation strategies, these typically require more expensive and complex systems, and the electricity consumption of the ventilation fans can still be very significant. Instead, air should only be used for health-based ventilation purposes while the thermal functions should rely on higher heat capacity mediums such as, for instance, water.

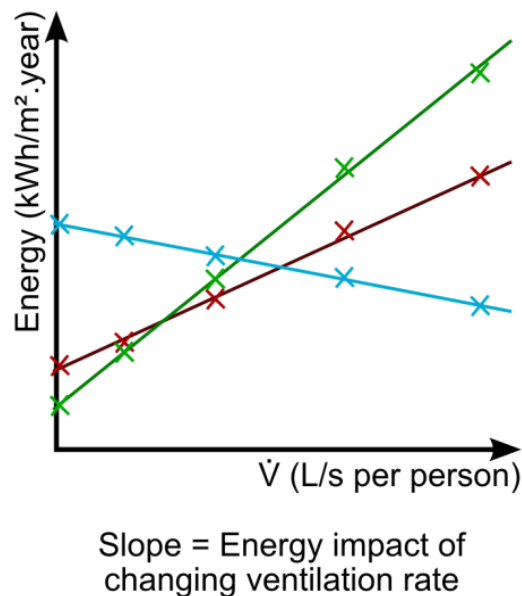

Figure 11. Energy impact of changing ventilation rate as the slope of the graphical representation of energy needs versus ventilation rate.

The fact that the ventilation impacts on the buildings' heating and cooling needs is well-known. Indoor air tends to be warmer than the ambient air due to internal and solar gains, and in many cases to mechanical heating itself. For that reason increased ventilation, no matter whether natural or mechanical, usually results in a cooling effect. For most countries in Europe heating needs usually dominate the energy use of buildings and therefore it would be expected that the cooling effect of ventilation would result in increased energy consumption. The relation between energy use and ventilation, or more specifically the magnitude of dependency of the former concerning the latter, is determined by numerous factors and local conditions. Building type, local climate, heating and cooling set points, demand control, usage of free-cooling techniques, heat-recovery, building airtightness and

humidity control, among others, may have a significant impact on the variation of energy consumption as a function of ventilation rate.

HealthVent's WP6 aimed at assessing the impact of changing ventilation rates on the European buildings' energy use. The impact was characterized by the trend of the line slope of the graphical representation of energy needs as a function of ventilation rate (Figure 11), in units of kWh/(m².year) per L/s per person. This includes the energy needs for heating, cooling and moving the air (when mechanical means are used).

The objective was achieved through the analysis of a comprehensive set of scenarios, whose results in terms of annual energy needs for heating and for cooling were estimated through detailed building simulation. The range of scenarios addressed four different building types (a detached house, an apartment, an office and a school), three different climates/locations (Lisbon, Paris and Helsinki), three different heating and cooling set point ranges, use of heat recovery equipment, four different building airtightness ratings, four air flow control strategies, and three relative humidity control options. Furthermore, ventilation rates from 0 to ~13.9 L/s per person were considered, in principle enough to cover the range of interest of such study. For each building/location a combination of typical construction characteristics (12 in total) were compiled with the help of local experts.

Countries with colder climates tend to require more thermal insulation, airtightness and heat recovery. These aspects were taken into account in the building models used in the simulations at each location. Because of that fact the differences on energy needed for heating, cooling and ventilating the buildings are usually smaller than what could be inferred from the climatic heating degree-days and cooling degree-days ratings for each of the locations.

Table 6. Impact of changing ventilation rate on thermal and final energy, either using current practice or advanced systems (in kWh/(m².year) per L/s per person).

		THERMAL ENERGY NEEDS (heating + cooling)		ELECTRICITY NEEDS (to drive fans)	
BUILDING TYPE	CITY	Current Practice	Advanced System †	Current Practice	Advanced System †
Detached House	Lisbon	1.9 *	0.1	0.5	0.3
	Paris	0.8	0.2	0.9	0.3
	Helsinki	1.4	0.4	0.9	0.3
Apartment	Lisbon	1.8 *	0.0	0.3	0.0
	Paris	0.9	0.2	0.7	0.0
	Helsinki	2.0	0.5	0.7	0.0
Office	Lisbon	0.0	0.0	0.6	0.1
	Paris	-0.1	0.0	0.6	0.1
	Helsinki	0.2	0.3	0.6	0.1
School	Lisbon	0.2	0.0	1.1	0.2
	Paris	1.3	0.7	1.1	0.2
	Helsinki	2.6	1.6	1.1	0.2

† Advanced systems make use of heat-recovery on a very airtight building with demand control and free-cooling strategies.

* Current practice on residential buildings in Lisbon does not rely on the use of heat-recovery (contrary to Paris and Helsinki)

Considering the standard practice at each location, the variation on useful energy needs for heating and cooling associated with the ventilation rate comes at about 1 to 2 kWh/(m².year) per L/s per person in residential buildings, nearly zero in the office building and up to 2.6 kWh/(m².year) per L/s per person in the school building (Table 6). Taking also into account the electricity needed to drive the ventilation fans (in the case of mechanical systems), the impact of changing ventilation rate on the building's final energy use is about 0.3 to 0.9 kWh/(m².year) per L/s per person in residential buildings, 0.6 in the office building and 1.1 in the school building. That is, changing the ventilation rate by 1 L/s per person on current practice systems, results in an increase on energy use that can range from almost nothing to nearly 3 kWh/m² per year on thermal energy needs and ½ to 1 kWh/m² per year on final energy use just for moving the air (for mechanical systems).

The use of more advanced systems coupled with better construction quality (more specifically concerning building airtightness) and air flow control strategies also present a significant opportunity for decreasing the variation of the building's energy use due to ventilation rate changes. Table 6 also shows the results for an "advanced system" which assumes the use of heat-recovery with a very airtight building envelope, demand control and free-cooling. Typically a very significant reduction is seen in the building's energy sensitivity to changes in ventilation rate, be it on useful energy needs for heating and cooling, or on final energy, in the form of electricity (assuming the use of heat-pumps), for heating, cooling and moving the air on a mechanical ventilation system. The results for the residential buildings on thermal energy needs vary from 0.1 to 0.5 kWh/(m².year) per L/s per person, up to 0.3 in the office building and up to 1.6 in the school. As for the electricity needed to drive the ventilation fans, the impact of ventilation is reduced to about 0.3 kWh/m² per L/s per person on the detached house, to less than 0.05 in the apartment, about 0.1 in the office and about 0.2 in the school building.

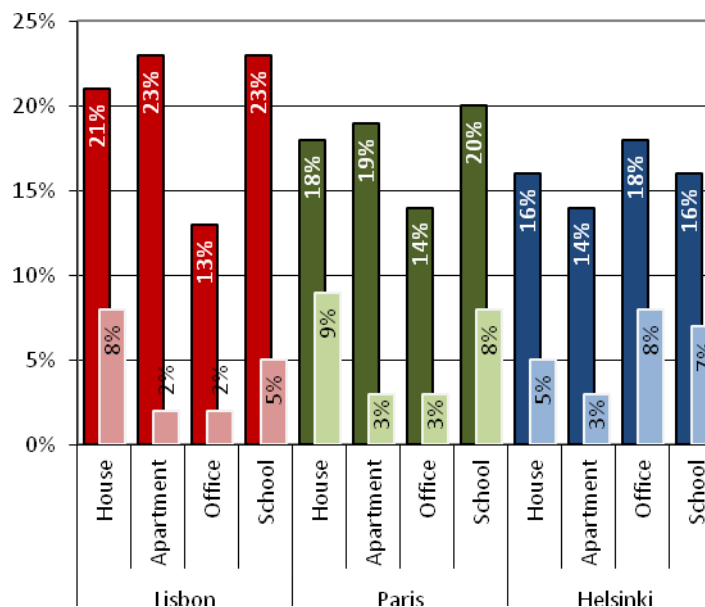

Figure 12. Impact of changing ventilation rate by 2 L/s per person from a base of 4 L/s per person in all 12 base cases (three locations and four building types), when using a current practice system (darker columns) or when using an advanced system (lighter columns).

In practice, that means that changing the ventilation rate by, for instance, 2 L/s per person from a base of 4 L/s per person, as graphically shown in Figure 12, would have an impact on final energy needs of about 13% to 25% on final energy use for heating, cooling and ventilating when using a current practice system. If an advanced system is in place, however, the impact is significantly smaller and the results show a variation of lower than 10% on final energy needs for such an action.

In fact the relationship between indoor air quality and outdoor air quality is also tightly linked to the building's quality of construction and maintenance and affected through natural ventilation and infiltrations, in the sense that the building is never airtight and therefore outdoor pollution sources always tend to have an impact on the air quality indoors.

Indoor sources emit a wide spectrum of pollutants, chemicals and particles that, in part, are similar to the ambient air pollutants. For this reason most of the indoor relevant pollutants which were considered and prioritised in the WHO IAQ Guidelines (WHO, 2009; WHO, 2010), coincide with most of the ambient pollutants in the WHO AQ Guidelines except for particulate matter that only included in the latter and the biologic pollutants for which IAQ guidelines have been issued separately.

3.2.2 Impact on elevated temperatures and moisture

Humidity released in the normal daily activities such as cooking, bathing, washing and laundry drying should ideally be removed by local extract ventilation and exhausted directly outdoors and not mixed into recirculation, if mechanical ventilation is used. The occasional wider moisture generating activities such as floor and window washing should be managed by additional ventilation capacity and not base capacity, such as through extensive natural ventilation, i.e. opening of windows and/or doors.

The most important remaining need for natural ventilation may be for cooling during high outdoor temperatures. Because buildings absorb and store solar heat, and heat is also generated by virtually all human activities and technical equipment in the buildings, occupied buildings are in average naturally warmer [5 to 10 °C] than outdoor air unless cooled by some means. Excessive indoor temperature is not only uncomfortable, but it also may reduce productivity and associated to increased mortality (Basu & Samet, 2002). In recent years some heat waves in Europe were believed to have caused tens of thousands of excess deaths within just a few weeks, e.g. 70 000 excess deaths during the West European heat wave of August 2003 (Robine *et al.* 2008). This is a much debated issue that cannot be stated that simply. Heat waves may cause deaths but one shall bear in mind the actual living conditions in low quality buildings of some suburban areas and the elder people living there alone for most of the day is not enough hydrated.

The traditional means of keeping indoor spaces cool are shading and ventilation, in particular, free night ventilation. In modern buildings these means are increasingly amended or replaced by mechanical cooling (air conditioning) which is integrated into the mechanical ventilation system but leading very often to ventilation rates that are several times higher than the values that could be found using the health-based ventilation criteria. In many hot and humid climatic zones the mechanical systems, in particular for cooling, tend to consume considerable

and increasing proportions of the electric power and tend to create high afternoon peak demands at summer time.

For this reason, decoupling of ventilation from heating/cooling, needs to become the main strategy except for the case of natural ventilation which in this particular case is a straightforward way of free cooling. Hot summer days are common in large parts of Europe, but (unlike e.g. in South-Eastern Asia) the nights remain mostly cool and the humidity of the air keeps quite low. It is therefore possible and highly recommended to rely on improving and expanding (and eventually automating) the traditional Mediterranean natural ventilation practice of night-time cooling by convective airflows. This requires much higher air exchange rates than those achievable by typical mechanical ventilation systems. Night-time cooling by convective airflows can be enabled and be sufficient by a combination of building's design and natural ventilation on a daily basis procedure (Santamouris M. and Asimakopoulos D., 1996).

While the otherwise optimised mechanical ventilation rates are insufficient for night-time cooling in hot summer days, sufficient air exchange rates can be achieved by natural ventilation through large windows to be kept open during night at least in two opposite sides of the building when indoor temperature exceeds outdoor temperature.

3.2.3 Impact on filtration and penetration of outdoor air pollution

Outdoor air is a major source of health risks associated to indoor exposures (Hänninen et al., 2004, 2005, de Oliveira Fernandes et al., 2009, Jantunen et al., 2011). This is due to the fact that outdoor air pollutants are conveyed indoors through ventilation. Even in the cases of theoretically efficient filtering of intake air, detailed studies have shown that in real life situations a substantial fraction of the outdoor air enters indoors via windows, doors, ventilation ducts, and cracks and leaks in the building's envelope, leading to much lower actual filtration efficiency (Fisk et al., 2002). Moreover, the European Commission's assessment based on extensive air quality monitoring network and complementary statistical and physical modelling has shown that only 9% of European Union citizens live in areas where the WHO guideline of $10 \mu\text{g m}^{-3}$ for annual average of $\text{PM}_{2.5}$ concentration (WHO, 2006) is achieved (Leeuw & Horalek, 2009).

For the protection of public health, definition of the needed filtration efficiency must be based mainly on long-term average contribution of outdoor pollution sources to indoor pollutant concentrations. These can be quantitatively described using the following mass-balance equation (Dockery and Spengler, 1981):

$$\overline{C}_i = \frac{Pa}{a+k} \overline{C}_a + \frac{G}{V(a+k)} - \frac{\Delta C_i}{\Delta t(a+k)} \quad (\text{Eq. 1})$$

According to the mass-balance of Eq.1, the indoor concentration of a pollutant originating from outdoor air (C_{ai}) depends on the penetration efficiency (P; probability of a particle to be carried through the building envelope with air intake), the air exchange rate (a; h^{-1}) and the decay rate of particles indoors (k, h^{-1}):

$$C_{ai} = \frac{Pa}{a+k} C_a = F_{INF} \times C_a \quad (\text{Eq. 2})$$

In the case of particulate matter the decay rate is mainly driven by thermokinetic and gravimetric deposition. The decay rate is strongly dependent on the particle size and for the simplified approach used here the default values shown in Table 7 are used.

Table 7. Mass-balance parameters of the outdoor pollutants considered.

	MASS BALANCE PARAMETERS					
POLLUTANT	Dp(eff) μm	Density ρ (g cm ⁻³)	Penetration [fraction]		Decay k (h ⁻¹)	F _{INF}
PM _{2.5}	2	1.5	90 %		0.32	0.55
Pollen	10	1.0	80 %		5.41	0.07

According to the mass-balance equation, when assuming constant outdoor pollution and penetration efficiency, the indoor concentration originating from outdoors increases as function of the air exchange rate. Filtration of outdoor air is necessary for protecting health of the occupants in cases when the outdoor air is contaminated. Because both ultrafine and coarse particles have much lower penetration efficiencies and higher deposition rates indoors, PM_{2.5} is suitable for controlling the contribution of outdoor pollution indoors. Moreover, the current approach is using the long-term WHO guideline value for PM_{2.5}, set at 10 μg m⁻³ as an annual average, for quantifying the needed efficiency of filtration of outdoor particles at a given location. This guideline value was set based on ambient air related epidemiological studies conducted using urban background monitoring station data on outdoor pollution concentration levels. Depending on the building stock in each city of these studies (e.g. 6 in the Harvard Six Cities study (Dockery et al., 1993); 150 in the American Cancer Society study (Pope et al., 2002)), the corresponding indoor reference concentration of PM_{2.5} may have varied from 4 to 8 μg m⁻³. For the purposes of determining the filtration efficiency in the HealthVent ventilation guidelines framework, a central value of 6 μg m⁻³ was chosen as the reference concentration (C_{ref}). Now the needed effective penetration efficiency of the whole building can be solved from the mass-balance equation as:

$$P_{eff} = \frac{C_{ref}}{C_a} \times \frac{a+k}{a} \quad (\text{Eq. 3})$$

Even in the case of mechanical ventilation systems using high quality filtering of the intake air, the effective penetration efficiency is strongly dependent on the overall tightness of the house. Penetration efficiency of particles entering indoors via windows, doors and cracks in the building envelope approaches unity, and the effective average penetration efficiency is thus determined by the filtration efficiency (P_{filter}) and fraction of air bypassing the filter (f).

$$P_{eff} = 1 - fP_{filter} \quad (\text{Eq. 4})$$

Solving for the filter efficiency (P_{filter}) yields:

$$P_{filter} = \frac{1 - P_{eff}}{f} \quad (\text{Eq.5})$$

Obviously, the filter efficiency has to be balanced against the leakiness of the system as leaky conditions the filter efficiency required may easily exceed 100%.

Table 8. National efficient filtration requirements (P_{eff}) to reach indoor level corresponding to WHO Guidelines for PM_{2.5} at baseline and when using base ventilation.

Country	PM _{2.5} ^b µg m ⁻³	Air exchange rates in 2010				Allowable infiltration ^a	
		Mean h ⁻¹	Median h ⁻¹	25 % h ⁻¹	95 % h ⁻¹	2010 1	4 L/s pp 1
Austria	17.2	0.85	0.7	0.46	1.07	0.48	-
Belgium	18.7	0.71	0.58	0.38	0.89	0.47	0.95
Bulgaria	22.3	0.71	0.58	0.38	0.89	0.39	0.71
Cyprus	22.6	1.22	1	0.66	1.53	0.34	0.69
Czech Republic	23.1	0.62	0.51	0.33	0.78	0.39	0.72
Denmark	13.3	0.66	0.54	0.35	0.83	0.67	-
Estonia	10.8	0.66	0.54	0.35	0.83	0.82	-
Finland	9.1	0.65	0.53	0.35	0.82	0.98	-
France	12.3	0.64	0.53	0.34	0.80	0.73	-
Germany	16.0	0.68	0.56	0.36	0.85	0.55	-
Greece	20.8	0.96	0.79	0.52	1.21	0.38	0.77
Hungary	24.6	0.75	0.62	0.40	0.94	0.35	0.65
Ireland	7.6	0.57	0.47	0.31	0.72	1.24	-
Italy	19.6	0.76	0.62	0.41	0.95	0.44	0.99
Latvia	12.4	0.65	0.53	0.35	0.82	0.72	-
Lithuania	13.6	0.67	0.55	0.36	0.84	0.65	-
Luxembourg	12.1	0.87	0.71	0.47	1.09	0.68	-
Netherlands	18.7	0.67	0.55	0.36	0.84	0.47	-
Poland	22.2	0.69	0.57	0.37	0.87	0.39	0.61
Portugal	18.3	0.73	0.6	0.39	0.92	0.47	0.87
Romania	22.6	0.78	0.64	0.42	0.98	0.37	0.46
Slovakia	23.1	0.78	0.64	0.42	0.97	0.37	0.57
Slovenia	16.8	0.72	0.59	0.39	0.90	0.52	0.89
Spain	16.4	0.8	0.65	0.43	1.00	0.51	-
Sweden	10.4	0.64	0.52	0.34	0.80	0.87	-
UK	13.3	0.61	0.5	0.33	0.77	0.68	-
EU26	17.0	0.7	0.58	0.38	0.88	0.55	-

^a acceptable maximum infiltration to reach indoor PM_{2.5} concentration corresponding to WHO Air Quality Guidelines.

- indicates no need to limit infiltration.

^b Population-weighted mean outdoor concentration (de Leeuw & Horalek, 2009).

Thus the overall procedure for designing the building in terms of filtering outdoor air needs to account for the outdoor pollution level at the building site (C_a), the air exchange rate designed for normal use (a), and to solve the required effective penetration rate (P_{eff}). Additionally, in case of a mechanical ventilation system, the leakiness of the building (f) has to be balanced against the available filter efficiencies (P_{filter}). Using the $PM_{2.5}$ decay term ($k=0.32 h^{-1}$) are sufficiently covered also pollen and coarse and ultrafine particles having larger deposition velocities and typically more efficient filtration properties, too.

Table 8 lists the allowable efficient infiltration rates in EU-26 countries. The values have been calculated by using the population-weighted mean outdoor $PM_{2.5}$ level; thus in each country the actual filtration efficiencies still vary between individual building sites.

3.2.4 Potential for burden of disease reduction of different indoor exposure mitigation approaches

Europeans spend typically over 85-90% of their time indoors. Indoor air should thus be recognized as a significant determinant of population health.

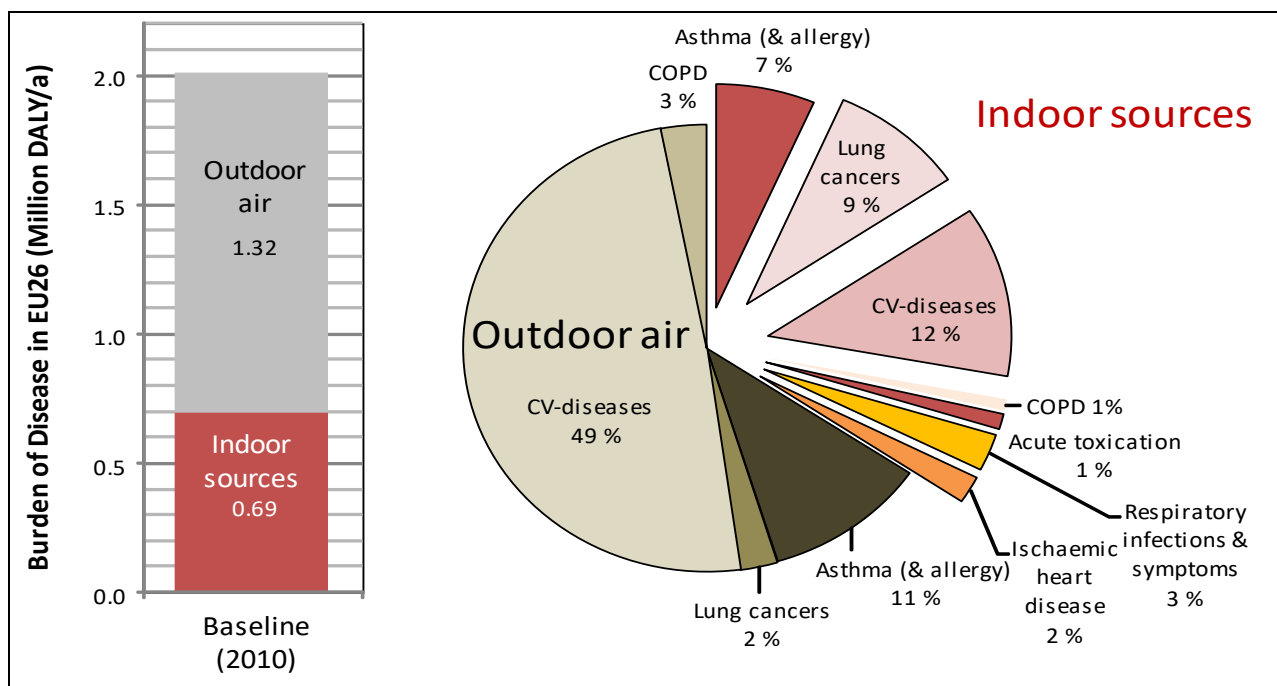

Figure 13. Burden of disease caused by indoor exposures in Europe (EU-26) by disease and origin of exposure (baseline year 2010)

Indoor air originates outdoors. Outdoor air brought indoors is carrying outdoor contaminants. The penetration degree depends on the ventilation load when natural ventilation is used or on the level of infiltration in case of mechanical ventilation. Some pollutants are effectively transferred indoors, e.g., for $PM_{2.5}$ infiltration has ranged from 50-90% in European studies (Hänninen et al., 2004, 2010). Other pollutants are adsorbed on indoor surfaces or readily react with indoor air pollutants (e.g. ozone, ultrafine and coarse

particles). Indoor environments, besides outdoor air pollutants, contain also sources of contaminants that are generated indoors. Pollutants in the confined spaces may potentially cause significant health risks. The burden of disease associated with major exposures indoors in 26 European countries was recently estimated to be 2 million healthy life years (DALYs) annually (Jantunen et al., 2011).

For the evaluation of the potential health impact of ventilation guidelines the model used for the burden of disease estimations was updated with baseline ventilation distributions by countries (Asikainen et al., 2012a; 2012b) and a mass-balance based exposure estimation (Hänninen et al., 2012a; 2012b). According to the HealthVent recalculation for the 2010 baseline year, 65% of the total burden of disease caused by indoor exposures originated from outdoor air. The burden is dominated by cardiovascular diseases (61%) followed by asthma and allergies (18%) and respiratory tract cancers (11%).

Three approaches were tested to evaluate the effectiveness of alternative ventilation scenarios (Table 9).

Table 9. Hypothetical health-based ventilation guidelines based scenarios for testing impacts on burden of disease.

HYPOTHETICAL HEALTH-BASED VENTILATION GUIDELINES BASED SCENARIOS FOR TESTING IMPACTS ON BURDEN OF DISEASE	
<i>Baseline scenario</i>	Existing building stock and existing distribution of mechanical ventilation by country
<i>Scenario 1</i>	Dilution of what and with what kind of air optimum
<i>Scenario 2</i>	Filtration of outdoor air: outdoor PM filtration by 50% (optimum at 7.7 L/s per person)
<i>Scenario 3</i>	Source control (-90% reductions for SHS, CO and Rn; -50% reductions for VOC and dampness; -25% reduction of indoor generated PM _{2.5}) (4 L/s per person)

The first scenario adjusts only ventilation rates, assuming that outdoor pollution, building stock and indoor sources remain constant (Figure 14). Only minor benefits (-20%) can be achieved with this strategy while the infiltration of outdoor pollution compensates the reduction in indoor source contribution at higher ventilation rates. In this scenario the European (EU-26) minimum burden of disease was achieved at a ventilation rate in the range of 1-8.8 L/s per person.

Due to the significant contribution of outdoor air, the second scenario was defined to attend this by assuming efficient filtration of outdoor air in all buildings. While keeping the indoor sources at the baseline level, now substantially larger health gains are projected (41%) (Figure 15). Filtration of the outdoor air allows higher ventilation rates and now the European health-based optimal ventilation rate was achieved at 14 L/s per person. In the second scenario, while WHO guidelines (e.g. for PM_{2.5}) are exceeded in areas where 91% of Europeans live (Leeuw & Horalek, 2009), filtration of outdoor air would need to be implemented in almost all buildings.

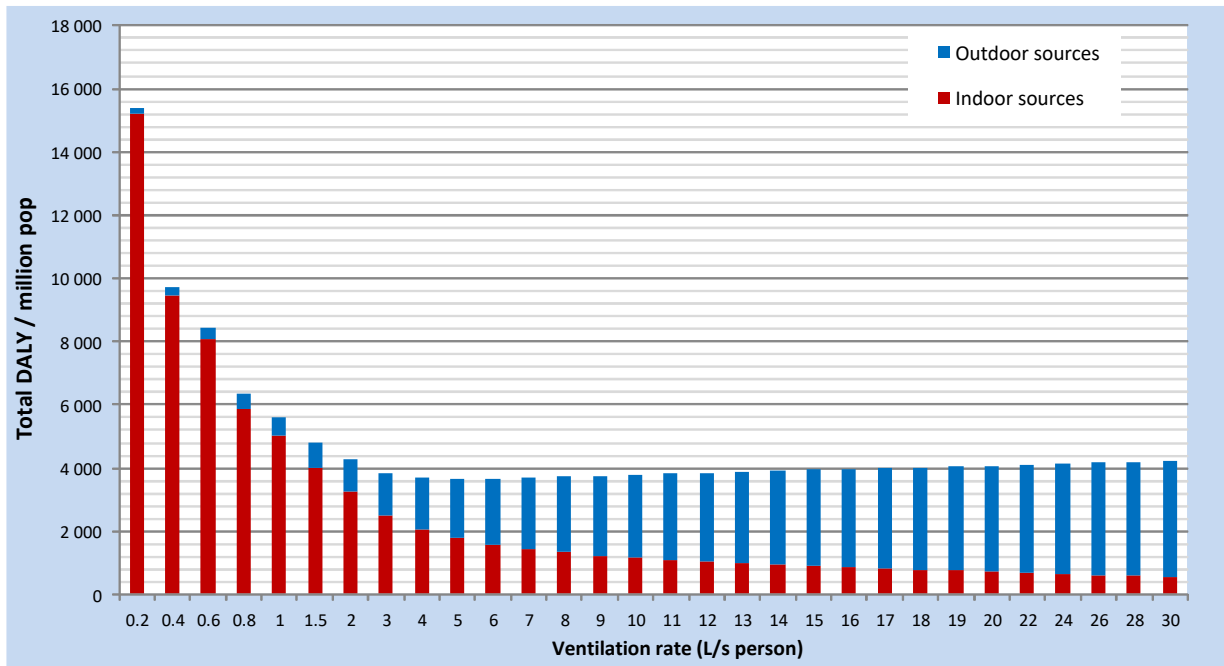

Figure 14. Changes in the burden of disease associated with indoor and outdoor sources in EU-26 as function of adjusting ventilation rate only.

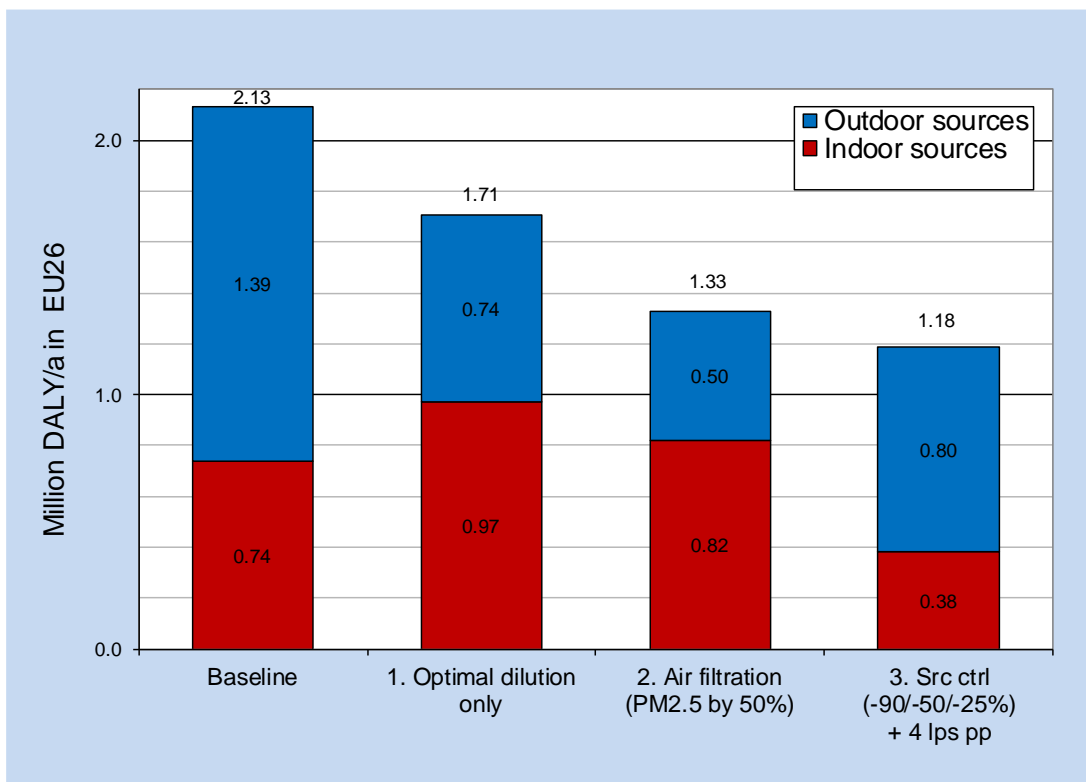

Figure 15. Comparison of burden of disease in Europe (EU-26) for alternative health-based ventilation guidelines scenarios.

The third scenario was developed to test the effectiveness of source control policies. Substantial but realistic reductions were defined as 90% for radon, second hand smoke and carbon monoxide exposures, 50% reduction of VOCs and dampness, and 25% reduction of indoor generated PM_{2.5}. When applied and combined with a minimum ventilation rate of 4 L/s per person, 55% reduction in the burden of disease is projected (Figure 15).

Thus the simulations for three alternative health-based ventilation guidelines based scenarios strongly support a strategy that combines controlling of indoor sources with a minimum ventilation rate, optionally supplemented with filtration of outdoor air when necessary.

3.3 Recommendations and harmonisation needs across EU policies

In the scope of the HealthVent project, quite a number of existing European Standards and Technical Reports on ventilation have been reported and subsequently classified into two groups:

1. Directly indoor air quality related standards addressing measures which can help to improve indoor air quality and dealing with functional properties of ventilation systems or equipment
2. Technical standards on ventilation dealing with mechanical properties and testing of ventilation systems and equipment but which do not specifically addressing measures that can influence indoor air quality.

The review of ventilation standards, which are listed under the group of IAQ related standards, showed that none of them is health based.

Standards which can be used for the determination of ventilation rates (EN 15251: 2007 and EN 13779: 2007) are based using different categories of comfort (based on standards EN ISO 7730: 2006 and CR 1752: 1998). The general rule applied to these standards is that higher comfort requires higher ventilation rates.

Indoor air quality in EN standards is defined poorly and only provides some general guidance on concentration levels of CO₂ and humidity. These two parameters are mentioned in EN 15251, whereas there are no other generally accepted criteria and methods for typical indoor air pollutants.

Although EU Member States have adopted standard EN 15251 as their national standard for indoor environmental input parameters in the design of energy performing buildings, national regulations prescribe values which often deviate from the values published in the EN standards.

Some EU countries in their national legislation have included exposure limits for indoor pollutants linked to ventilation regulations. Values which are included in national regulations on ventilation are however not consistent and present a wide range of ventilation rates for the same indoor pollutant considered.

The review of European regulations on ventilation rates, indoor pollutants, and indoor environment criteria also showed that regulations at EU Member States, in some cases, are inconsistent and contradictory across some countries. Moreover, the majority of all regulated parameters are already defined in European Standards, which were accepted in CEN voting process by national bodies. Nevertheless, values found in standards and those in regulations are not harmonised. The inconsistency and heterogeneity presented at national level between EN standards and regulations and on European level among countries is in contrast to the efforts of unification and standardization of the European common market and to the removal of existing barriers to trade. This hampers building designers and industry from making informed choices and increases the cost of constructions.

The review studies showed that ventilation rates, indoor environmental parameters and noise do not comply with regulations. Deviations between measured and required values are considerably big thus requiring corrective action to be taken.

The health-based ventilation rate in a specific building is defined when the WHO guidelines are met through an integrated preventive approach combining source control measures and health-based ventilation practices that guarantee the protection of health. A holistic approach is needed, defining the building and urban and indoor air quality role in a global sustainable context.

This approach requires integrated strategies, harmonised implementation practices and specific policy actions, as those which are recommended in the following:

- Inclusion of requirements on indoor air quality in the national regulations of all European countries is necessary such as a harmonised minimum number of pollutants and their associated limit levels according to the WHO IAQ and the EU-INDEX guidelines.
- Development of a common regulation on ventilation rates, which would harmonise calculation and measurement and auditing practices among countries and take care that required ventilation rates are health-based and implemented in connection with appropriate source control strategies to guarantee health protection while rationalising over the economic burden concerning investment, operation and energy use. Future recast of the Energy Performance Buildings Directive (EPBD) and revision of ventilation regulation should include IAQ aspects and auditing (source and emission control of indoor/outdoor sources). This can be greatly facilitated by and take advantage of the harmonisation framework for indoor air monitoring which was recently developed by the European Commission (DG JRC and DG SANCO) in the context of the PILOT INDOOR AIR MONIT project.
- In a future review of the EU Ambient Air Quality Directive integrate indoor air quality aspects while accounting for the associated environmental, health, social and economic impacts.
- Development of a new European guideline providing guidance on proper scope, design, construction, maintenance and inspections of ventilation systems. It can be considered to reinforce the maintenance and inspection of ventilation systems in parallel with inspections of air-conditioning systems and energy auditing under EPBD.
- Development of harmonized product labelling criteria to be used as part of ventilation rate design specification. Otherwise, if material emissions are not known the designer has to specify high, over ventilating ventilation rates according to non-low polluting class (see EN 15251 standard). This should be aligned with the two harmonization frameworks for indoor products labelling and health-based evaluation which were developed by the European Commission's Joint Research Centre (ECA Reports n° 27, 2012 and n° 29, 2013 respectively).
- Cross-cutting criteria for energy requirements decoupling health-based ventilation in relation to indoor air quality objectives from systems to achieve thermal comfort (i.e. heating/cooling) should be developed and aligned across various legislative instruments (e.g. Ecolabel criteria for various products, Ecodesign Directive Lot 6 on ventilation, CEN/TC 350/WG 5 prEN 16309 "Sustainability of construction works",

etc.). In real-life scenarios the appropriate ventilation rate should be chosen as a function of energy requirements, the quality of building materials used, the climatic zones, the building activities, the type of occupants and occupancy level (accounting for humidity and anthropogenic emissions), health-based criteria (devised from IAQ guidelines and epidemiological data), adjusted for the needs of various indoor settings (offices, schools, etc.) and consistently used across existing ventilation regulations and standards. Ensuring sufficient ventilation and energy efficiency requires optimisation and adaptability of ventilation levels according to the materials used, the type and level of occupancy and activities taken place in buildings following the health-based ventilation guidelines concept developed within the HealthVent project.

- Development of new EU policies promoting sustainable buildings that adapt to variations in indoor and outdoor sources and featuring passive/active control for moisture/dampness and avoidance of particles.

3.4 Recommendations for future research

The present review clearly identified gaps in knowledge regarding the associations between ventilation and health and pointed out needs for further research.

- The recommended approach to study the association between ventilation and health needs to be holistic and multidisciplinary and should try to establish correlations between indoor air pollution, ventilation and health effects also in relation to thermal comfort and energy efficiency.
- The first need is to assess indoor safe pollutant levels on the basis of existing and future IAQ guidelines and better characterize exposures for single chemicals and chemical mixtures. Lack of data on actual indoor exposures to different indoor and outdoor pollutants was a finding of particular concern. Population representative measurement campaigns on indoor exposures should be systematically included in future research programmes regarding all major types of buildings. These exposure measurements should include quantification of ventilation rates along with analysis of the impact of indoor and outdoor sources to human health. Studies are needed to provide information on potential pollutants transported from outdoors, their infiltration parameters and decay rates. Emissions from indoor sources in addition to carbon dioxide need to be incorporated in future projects and lowest concentrations of interest such as those developed in the EU-LCI harmonisation process should be considered. This will pave the way to labelling of building materials and control all potential sources indoors taking into account new technical and European policy developments.
- Ventilation measurements are performed using different techniques in various seasons and for different averaging times, sometimes using the CO₂ concentration as proxy to estimate ventilation rates. Future research should better document which ventilation measurements (using different techniques) are valid in a health-based context.
- Better characterization of outdoor air quality is needed and strictly linking to and integrating over indoor air quality.

- An important achievement of the HealthVent project was the identification of limitations and drawbacks in the state of art knowledge concerning optimal ventilation from the point of view of health risks and current morbidities. The inventory which was compiled on the ventilation practices of the European building stock revealed insufficient data on actual ventilation measurements. A way to circumvent this obstacle was to set up simulation models to establish a common basis for comparisons and subsequent recommendations. This affects all relevant assessments such as epidemiological studies on the relationship between ventilation and health and estimation of energy balances and trends. In order to fill in this gap specific studies need to be designed to assess actual ventilation rates and their seasonal trends in different building types (e.g. residences, offices, schools, kindergartens, etc.) while accounting for the climatic diversities across the European continent.
- Population-based representative studies on ventilation rates in different building types, associated with typical attendance times (8 h/d, 16 h/d, 24 h/d) and different room dimensions are needed. A gap to be filled would be the individual effects of commuting from one building type to another taking also into consideration different states of diseases through case-control studies.

To evaluate the burden of disease due to exposure to indoor air pollution, the common metric used by HealthVent and previous projects (e.g. IAIAQ) were Disability Adjusted Life Years (DALYs). Their calculation involves assumptions that may not reflect unequivocally an association between ventilation and different morbidities. Indoor air may contain pollutants that directly affect the respiratory system and causal relationships with other diseases (e.g. cardiovascular) may require specific study designs. This brings forward two important considerations:

- Which are the most relevant endpoints to use for assessing the health effects from indoor air exposure and the optimal ventilation rates to minimise the associated risks: allergy and asthma, air transmitted infectious diseases, other chronic non-communicable diseases like chronic obstructive pulmonary disease (COPD) or lung cancer? Allergic / non-allergic rhinitis is one of the most common chronic diseases relevant to all life ages with minor peculiarities beyond the plateau of adulthood; it could be used in population based studies to assess prevalence in association with different ventilation rates.
- While acute effects of indoor air are relatively easy to identify, novel approaches are needed to study chronic effects of exposures to different pollutants in relation to ventilation rates in real-life scenarios to minimise the associated risks.
- Are DALYs the most appropriate metric for future use? Is it at all feasible to rely on just one integral measure, or could other direct epidemiological indices such as incidence or prevalence be more appropriate for some specific purposes?
- More insight is needed on the role of humidity released by the occupants in relation to seasonal ambient temperature changes and the ventilation requirements to establish optimal control on indoor dampness and mould growth.
- Special considerations should be given subpopulations with special needs (i.e. vulnerable groups) as a step towards personalized type of medical care.

- Looking into the future intelligent smart systems conciliating general health-based ventilation guidelines satisfying over the individual perception of comfort should gradually be developed and implemented. This would require additional advancement of knowledge, technological innovation and technical implementation as required by the challenges set in the Europe 2020 strategy. The recent progress in the automatic control and technological developments of systems presents a real challenge to improve the performance of ventilation strategies. The progress in the development of simulation tools gives also a real opportunity to predict the coupled behaviour of a system and a building. Defining a set of variables, such as the efficiency of the system and controlling it over a set of quality indicators (e.g., humidity, CO₂, a few specific indoor air pollutants, energy consumption, etc.), makes it realistic to change the existing paradigm for ventilation as currently used in European countries in relation to the building's energy use. It also becomes realistic to replace existing prescriptive design guidelines or regulations by others that are more adapted and performance-based. This would promote a better indoor air quality and minimise the associated health risks with no unjustifiably high ventilation flow rates and energy consumption.

In concluding, it should be underlined that the aforementioned recommendations and needs for further research should be seen as a core framework which should be dynamically and progressively further expanded and complemented on the long-run.

4. PATIENTS' PERSPECTIVE AND GUIDELINES' PROMOTION

4.1 Patients' perspective

The air people breathe is fundamental for their life but in most cases there is no choice of the quality of air that is breathed. It is widely acknowledged that people with respiratory diseases are particularly susceptible to indoor air pollution. Indeed, in case of exposure to poor IAQ they are generally the first to react, as the symptoms of their disease exacerbate. For example, breathing poor IAQ has been linked with an increased risk of developing asthma and respiratory allergies especially for children. Patients with chronic diseases, especially if the nature of disease is severe, are likely to spend more time indoors than healthy people and in this way can additionally be at elevated risk. Consequently, the voice and personal experiences of patients with chronic respiratory diseases should be taken into account, when air quality related policies are developed and put into action.

The exposure to outdoor air pollution, tobacco smoke and other hazardous substances can have disastrous consequences for the daily lives of patients with respiratory diseases. Patients testify that particularly sensitive people may even experience life-threatening reactions when they enter into contact with the majority of everyday pollutants. These pollutants include: tobacco smoking, cooking and heating fumes and gases, pollutants occurring due to moisture and dampness, exhaust emissions and road dust penetrating the buildings, as well as, organic chemicals emitted from construction materials, finishing products, furnishing, cleaning agents, air-fresheners, personal hygiene and beauty care products. Serious symptoms may even be triggered by widely spread consumer goods, such as scented candles and incenses. Patients report that these latter products, while burning, release gases into the air making the lungs feel like they are filled with foam and causing the feeling of heavy chest (like a person would be standing on one's chest while trying to breathe). Consequently these people are left out of places and situations, like entering a cafe, going to a party, shopping, swimming and even attending an essential meeting for their work and many more activities that healthy people get involved into for granted.

Control of exposures for the patients with respiratory diseases through, for example, directed control of sources of indoor air pollution is absolutely instrumental for creating healthy living environments for them.

To this end protection of European citizens from the exposure to second hand smoke (SHS) is of utmost importance for adequate IAQ: tobacco smoke should be banned in enclosed public places, workplaces and in all forms of transportation across the EU without any further delay.

Regarding outdoor air pollution, it is extremely important to regulate ambient air according to the WHO air quality guidelines and the revisions of the EU ambient air legislation creating an exceptional opportunity for positive and constructive actions to support the aim of improved outdoor air quality.

The use of hazardous substances in indoor environments should be avoided wherever possible. Labelling systems should be introduced to make the consumers aware of the impacts of the products they buy and of the air quality of their homes, workplaces, schools and other

similar non-industrial environments. This information can direct health-conscious choices. These labels should be harmonised at EU level and easily understandable by the general public (that should thus be involved in their elaboration). Many of them can additionally include information on how to maintain IAQ or who is responsible for IAQ together with guidance on what can be done to improve IAQ in a cost effective way. The information should also include how ventilation and occupant behaviour can together affect IAQ both by improving or destroying it. Various factors can cause ventilation systems to underperforming including failure to replace filters by users or improper installation made by construction workers. From the patient's perspective with chronic respiratory diseases, the provision of sufficient information to users about a given ventilation system is necessary. This is analogous to selling the cars or domestic appliances with the user manuals containing sometimes hundreds of pages explaining how to achieve proper operation and maintenance and what should be done in case of malfunction. Lay-friendly user manuals with clear instructions for ventilation systems should be requirement on both sides the vendor and also the property owners.

Buildings in Europe should be sold upon presentation of "IAQ certificates for buildings". As a result, patients would benefit from having all necessary information regarding the effective control of IAQ in the buildings they intend to live/work. Additionally clear regulations are necessary to explain who is responsible for dealing with IAQ problems such as mould and dampness due to poor ventilation and/or water leakages. The users do not necessarily know if the responsibility to deal with and remediate IAQ problems is on the property owner or on the tenants; lack of this information often cause unnecessary delays in taking actions prolonging hazardous exposures not to mention increased costs and stress. These regulations should be easily accessible for everyone and written in a lay-friendly language.

The ability for the patients, and indeed any occupant of a building, to be well-informed as regards the control measures for IAQ can not only increase the frequency and quality of maintenance thereby reducing renovation and repair costs, but may also result in improving of the quality of life in both living and working environments. A concerted effort ensuring proper training of construction workers would be needed.

Tackling the human behavioural aspects of IAQ is particularly relevant for the empowerment of chronically ill patients. Assuring their right to live and work in environments that do not endanger the exacerbation of their disease and/or their life, is particularly important for patients with chronic respiratory diseases, who are especially sensitive to poor air quality. In the case of IAQ, it is a question of rights in exchange of responsibility; both should be equally addressed and only if political importance is given to good air quality at the EU level.

4.2 Guidelines' promotion

The need to regulate outdoor air pollution has continuously attracted the interest of policy-makers. The same treatment is not reserved to IAQ that is mistakenly believed to be a private problem concerning only a limited number of people in Europe and the way that they behave in their dwellings and buildings. On the contrary, depending on regional culture and outdoor climate, Europeans spend most of their time in indoor environments (offices, schools, homes or leisure places). Thus the framework for health-based ventilation guidelines need proper promotion which will additionally foster awareness of all actors at all levels: EU and national

policy and decision makers, professionals (building designers, architects, constructors), healthcare professionals, patients' organisations and the public at large.

Firstly they should be addressed in the forthcoming developments of relevant policies such as the review of EU ambient air legislation as already done during the legislative process of the Seventh Environmental Action Programme where the European Parliament and the Council of EU in which IAQ related actions have been embedded among other main environmental challenges in Europe; it may provide opportunity to place all stakeholders in a prime position to follow-up on the topic of IAQ and represents the perfect moment to give political resonance to the issue of IAQ.

The health-based ventilation guidelines framework should also be promoted through special events organized at pan-European level or by events organized at the European Parliament and be addressed to politicians and relevant stakeholders. Focus should be on the impact of the guidelines framework on several existing building related EU policies (in particular regarding health, air quality, energy, eco-design and eco-labelling of construction and consumers products) and provide useful advice to national, regional and local policy-makers on the need to align the guidelines framework with EU legislations and national codes and standards.

Various publications should present the guidelines framework targeting different groups. They should include scientific papers published in peer-reviewed journals for healthcare professionals, technical papers for ventilation, building practitioners and industry as well as policy papers and popular papers for public at large. These publications should be accompanied by press releases. All results and related publications should be made publicly available online and presented during relevant EU and international high level conferences and congresses. This will ensure that all stakeholders and interested actors will be able to use the findings in future policy-making and advocacy.

5. CONCLUSIONS

Source control is the key element for controlling indoor air exposures

- Source removal and other source control measures must be applied before determining health-based ventilation rates, ventilation being an ultimate and supplementary measure for improving indoor air quality in buildings.
- As outdoor air is an important source of exposures occurring indoors, actions must be taken to control that outdoor air quality at city level and the surroundings of buildings respects the EC ambient air quality limits and WHO guidelines values for pollutants commonly found in both outdoor and indoor environments.. The responsibility for keeping the ambient air clean should be placed on national and local authorities. The building architects should also consider the aspect of building location so that the potential impact of ambient pollution is minimized already at the design phase of a new construction.
- When the ambient air quality related requirements are not fulfilled then the use of adequate specific ventilation systems (e.g. mechanical ventilation systems with filters and air cleaning capabilities) to provide fresh air in buildings (other than via natural ventilation) for achieving appropriate healthy indoor air quality levels should be evaluated on a case by case basis and not mandated on a generalised basis.

Air quality must comply with EC ambient air quality limits and WHO guidelines

- The European Commission's ambient air quality limits and the WHO indoor air quality guidelines must be respected at any building location.

The "health-based ventilation rate" in a specific building

- The "health-based ventilation rate" for a specific building is defined when the WHO air quality guidelines are met through an integrated approach following the principles of primary prevention which combines source control measures and health-based ventilation practices that guarantee the protection of health. Both indoor and outdoor air pollution sources should be tackled through coordinated actions as equally important for human health.

The health-related "base ventilation rate" defined as 4 L/s per person

- The health-related "base ventilation rate" is defined on the grounds of CO₂ and relative humidity produced by humans, i.e. assuming that the only sources of pollution are human bio-effluents.

Health-based ventilation rate cannot be lower than the "base ventilation rate"

- The base ventilation rate has been defined to create a true benchmark and reference point for defining ventilation rates based on health criteria admitting that rates lower than the base ventilation rate are not allowed. In case the EC ambient air quality limits

and the WHO IAQ guideline values are not met the “health-based ventilation rate” should be a multiple of the “base ventilation rate”.

Health-based ventilation always refers to a person

- The health-based ventilation rate should be expressed as volume rate per person rather than as volume rate (i.e. as number of air changes per unit time)

Health-based ventilation should be decoupled from systems for controlling thermal comfort

- Systems used for controlling thermal conditions (heat, cold and moisture) should be calculated and designed separately from ventilation used for reducing health risks associated to indoor air pollution.

Ventilation systems must support health-based ventilation criteria

- Guidelines for the proper design, operation and maintenance of ventilation systems should be always respected To guarantee that ventilation are functioning properly thus not compromising indoor air quality and increasing associated health risks by becoming itself source of pollution.

Legislative framework and research actions are needed to support the implementation of the framework of the health-based ventilation guidelines

- The framework for health-based ventilation guidelines should allow for the identification of key responsibilities of various key stakeholders (ranging from building designers and constructors to building managers and users) to ensure that the building’s design, maintenance and operation respect the framework’s concept and requirements.

Gaps in knowledge

- The population representative measurement campaigns on indoor exposures for various typologies of buildings should be carried out to fill the gaps in knowledge on the effects of ventilation and indoor air exposures on health. These measurement campaigns should include a much better characterization of ventilation and exposures than it has been previously done. They should also investigate in detail the role and impact of indoor and outdoor sources on chronic diseases. Particular emphasis should be given to vulnerable groups such as patients with chronic respiratory diseases.

6. REFERENCES

- AIRLOG. Integrated platform for intelligent indoor air quality audit management. <http://www.iaq-airlog.eu>
- AIRMEX. European Indoor Air Monitoring and Exposure Assessment - AIRMEX project. Available from: http://ihcp.jrc.ec.europa.eu/our_databases/airmex
- Arlian L.G., Neal J.S., Morgan M.S., Vyszynski-Moher D.L., Rapp C.M., Alexander A.K. 2001. Reducing relative humidity is a practical way to control dust mites and their allergens in homes in temperate climates. *J Allergy Clin Immunol.* Jan;107(1):99-104.
- ASHRAE 2001. ASHRAE Standard 62. Ventilation for Acceptable Indoor Air Quality.
- ASHRAE 2004. ASHRAE Standard 5. Energy-Efficient Design of Low-Rise Residential Buildings.
- ASHRAE 2010 Standard 55. Thermal Environmental Conditions for Human Occupancy.
- Asikainen A., Hänninen O., Kuhn A., Yang A., Loh M., Gerharz L., Brelih N., Jantunen M., 2012a. Modelling residential ventilation rates in European countries. *Proceedings of Healthy Buildings Conference, Brisbane, 2012-07-8..12.*
- Asikainen A., Hänninen O., Brelih N., Leal V., Allard F., Wargocki P., 2012b. Proportion of residences in European countries with ventilation rates below the limit defined by regulations. *Ventilation 2012, Paris, 17-19 September, 2012.*
- ASTM 2012. D6245 – Standard Guide for Using Indoor Carbon Dioxide Concentrations to Evaluate Indoor Air Quality and Ventilation. West Conshohocken, PA: ASTM International. doi:10.1520/D6245-12
- Basu R., Samet J.M. 2002. Relation between elevated ambient temperature and mortality: a review of the epidemiologic evidence. *Epidemiologic Reviews*, 24:2, 190-202
- Berg-Much, B, Clausen, G., and Fanger P.O. (1986) Ventilation requirements for the control of body odor in spaces occupied by women, *Environment International*, 12, 195-199.
- Bornehag C.G., Sundell J., Hägerhed-Engman L., Sigsgaard T., 2005. Association between ventilation rates in 390 Swedish homes and allergic symptoms in children. *Indoor Air*; 15: 275–280.
- Brelih N., 2012. Ventilation rates and IAQ in national regulations. REHVA – Federation of European Heating, Ventilation and Air Conditioning Associations.
- Carrer, P. e t al. 2012. Ventilation and health: review of the scientific literature (HealthVent project), *Proceedings of Healthy Buildings Conference 2012, Brisbane.*
- Coley D.A., Greeves, R., Saxby B.K. 2007. The effect of low ventilation rates on the cognitive function of a primary school class. *International Journal of Ventilation*, 6(2), 107–112.
- CEN Report CR 1752, 1998. Ventilation for buildings - Design criteria for the indoor environment. CEN. Brussels.

Construction Products Directive. Council Directive 89/106/EEC of 21 December 1988 on the approximation of laws, regulations and administrative provisions of the Member States relating to construction products; Official Journal L 040, 11/02/1989 P. 0012 – 0026; 1989.

Construction Products Regulation. Regulation (EU) No 305/2011 of the European Parliament and of the Council of 9 March 2011 laying down harmonised conditions for the marketing of construction products and repealing Council Directive 89/106/EEC; 2011.

De Leeuw F, Horalek J, 2009. Assessment of the health impacts of exposure to PM2.5 at a European level. European Topic Centre on Air and Climate Change (ETC/ACC), Technical paper 2009/1.

De Oliveira Fernandes E., Jantunen M., Carrer P., Seppänen O., Harrison P., Kephelopoulos S., 2009. Co-ordination Action on Indoor Air Quality and Health Effects (ENVIE). Final report, 165 pp. (accessed 2011-11-10).

Dimitroulopoulou C., 2011. Ventilation in European dwellings: A review. *Building and Environment*; 47: 109-125

Dockery D.W., Spengler J.D., 1981. Personal exposure to respirable particulates and sulfates. *JAPCA* 31: 153-159.

Dockery D.W., Pope C.A.III, Xu X., Spengler J.D., et al. 1993. An association between air pollution and mortality in six U.S. cities. *N. Engl. J. Med.* 329:1753-1759.

ECA 2005. Report No 24. Harmonisation of indoor material emissions labelling systems in the EU, Inventory of existing schemes, EUR 21891 EN, 2005.

ECA Report No 27 Harmonisation Framework for Indoor Products Labelling Systems in EU, EUR 25276 EN, 2012.

EN 2007 EN Standard 15251 - Indoor environmental input parameters for design and assessment of energy performance of buildings addressing indoor air quality, thermal environment, lighting and acoustics, CEN.

EN 2007 EN Standard 13779 - Ventilation for non-residential buildings - Performance requirements for ventilation and room-conditioning systems.

EN ISO 7730, 2006. Ergonomics of the thermal environment - Analytical determination and interpretation of thermal comfort using calculation of the PMV and PPD indices and local thermal comfort criteria. EN ISO.

Engvall K., Wickman P., Norback D., 2005. Sick building syndrome and perceived indoor environment in relation to energy saving by reduced ventilation flow during heating season: a 1 year intervention study in dwellings. *Indoor Air*; 15: 120–126.

Erdmann C.A., Apte M.G., 2004. Mucous membrane and lower respiratory building related symptoms in relation to indoor carbon dioxide concentrations in the 100-building BASE dataset. *Indoor Air*; 14 (Suppl 8): 127–134.

DIRECTIVE 2008/50/EC OF THE EUROPEAN PARLIAMENT AND OF THE COUNCIL of 21 May 2008 on ambient air quality and cleaner air for Europe (<http://eur-lex.europa.eu/LexUriServ/LexUriServ.do?uri=OJ:L:2008:152:0001:0044:EN:PDF>).

Fisk W.J., Faulkner D., Palonen J., Seppänen O., 2002. Performance and costs of particle air filtration technologies, *Indoor air*, 12, 223–234.

- Fisk W.J., Mirer A.G., Mendell M.J., 2009. Quantitative relationship of sick building syndrome symptoms with ventilation rates. *Indoor Air*; 19: 159–165.
- France 2012. Décret n° 2012-14 du 5 janvier 2012 relatif à l'évaluation des moyens d'aération et à la mesure des polluants effectuées au titre de la surveillance de la qualité de l'air intérieur de certains établissements recevant du public. JORF n°0005 du 6 janvier 2012 page 262 texte n° 17.
- Godish, T., Spengler J.D., 1996. Relationships between ventilation and indoor air quality: a review. *Indoor Air*, 6(2), 135–145.
- Harriman L.G., Brundrett G.W., Kittler R., 2001. Humidity control design guide for commercial and institutional buildings, ASHRAE, Atlanta GA.
- Hasegawa A., Goto T., Yoshino H., Iino Y., Muramatsu, S., 2012. Regulations and standards for indoor air environment (IAE) in schools - an international review. *Healthy Buildings*. Queensland: Queensland University of Technology.
- Hänninen O., Lebet E., Ilacqua V., Katsouyanni K., Künzli N., Srám R.J., Jantunen M., 2004. Infiltration of ambient PM_{2.5} and levels of indoor generated non-ETS PM_{2.5} in residences of four European cities. *Atmospheric Environment* 38, 6411-6423.
- Hänninen O., Palonen J., Tuomisto J., Yli-Tuomi T., Seppänen O., Jantunen M.J., 2005. Reduction potential of urban PM_{2.5} mortality risk using modern ventilation systems in buildings. *Indoor Air* 15 (4): 246-256.
- Hänninen O., Hoek G., Mallone S., Chellini E., Katsouyanni K., Kuenzli N., Gariazzo C., Cattani G., Marconi A., Molnár P., Bellander .T, Jantunen M., 2011. Seasonal patterns in ventilation and PM infiltration in European cities: review, modelling and meta-analysis of available studies from different climatological zones. *Air. Qual. Atmos. Health* 4(3-4):221-233.
- Hänninen O., Asikainen A., Bischof W., Carrer P., Seppänen O., de Oliveira Fernandes E., Warcocki P., 2012a. Health implications of alternative potential ventilation guidelines. *Proceedings of Healthy Buildings Conference 2012, Brisbane*.
- Hänninen O., Asikainen A., Allard F., Bischof W., Carrer P., Seppänen O., Leal V., Kephelopoulos S., Warcocki P., 2012b. Optimal ventilation: Balancing exposures to indoor and outdoor pollutants. *Ventilation 2012, Paris, 17-19 September, 2012*.
- Leeuw F., Horalek J., 2009. Assessment of the health impacts of exposure to PM_{2.5} at a European level. ETC/ACC Technical Paper 2009/1.
- Mendell, M.J. 1993. Non-specific symptoms in office workers: a review and summary of the epidemiologic literature. *Indoor Air* 3 , 227-236.
- Mendell M.J., Lei - Gomez Q., Mirer A.G., Seppänen O., Brunner G., 2003. Risk Factors in Heating, Ventilating, and Air Conditioning Systems for Occupant Symptoms in U.S. Office Buildings: the U.S. EPA BASE Study. *Indoor Air Journal*, volume 18, no. 4, pages 301-316
- Janssen J.E. (1999). The History of Ventilation and Temperature Control. *Ashrae Journal*.
- Jantunen M., de Oliveira Fernandes E., Carrer P., Kephelopoulos S., 2011. Promoting actions for healthy indoor air (IAIAQ). European Commission Directorate General for Health and Consumers. Luxembourg. ISBN 978-92-79-20419-7.

http://ec.europa.eu/health/healthy_environments/docs/env_iaiaq.pdf (accessed 2011-11-10)

Jones, A.P., 1999. Indoor air quality and health. *Atmospheric Environment*, 33(28), 4535–4564.

Koistinen K., Kotzias D., Kephelopoulos S., Schlitt C., Carrer P., Jantunen M., Kirchner S., McLaughlin J., Mølhave L., de Oliveira Fernandes E., Seifert B., 2008. The INDEX project: executive summary of a European Union project on indoor air pollutants. *Allergy*, 63(7): 810–9.

Kotzias D., Koistinen K., Kephelopoulos S., Schlitt C., Carrer P., Maroni M., Jantunen M., Cochet C., Kirchner S., Lindvall T., McLaughlin J., Mølhave L., de Oliveira Fernandes E., Seifert B., 2005. The INDEX project. Critical appraisal of the setting and implementation of indoor exposure limits in the EU. Final Report. EUR 21590 EN. European Commission, Directorate General, Joint Research Centre.

Pope III C.A., Burnett R.T., Thun M.J., Calle E.E., Krewski D., Ito K., et al., 2002. Lung cancer, cardiopulmonary mortality, and long-term exposure to fine particulate air pollution. *JAMA* 287 (9), 1132–1141.

RADPAR project. Radon Prevention and Remediation. <http://web.jrc.ec.europa.eu/radpar>

Robine J.M., Cheung S.L.K., Le Roy S., et al., 2008. Death toll exceeded 70,000 in Europe during the summer of 2003. *Les Comptes Rendus/Série Biologies*, , 331:171–78.

Santamouris M. and Asimakopoulos D., 1996. Passive cooling of buildings. James and James (Scientific publishers), UK 1996.

Satish U., Mendell M.J., Shekha, K., Hotchi T., Sullivan D., Streufert S., Fisk W.J., 2012. Is CO₂ an Indoor Pollutant? Direct Effects of Low-to-Moderate CO₂ Concentrations on Human Decision-Making Performance. *Environmental Health Perspectives*, 120, 1671–1677.

Seifert B., Levin H., Lindvall T., Moschandreas D., 1993. A critical review of criteria and procedures for developing indoor air quality guidelines and standards. *Proceedings of Indoor Air*, Vol. 3: 465-470.

Seppänen, O. A., Fisk, W.J., & Mendell, M. J., 1999. Association of ventilation rates and CO₂ concentrations with health and other responses in commercial and institutional buildings. *Indoor Air*, 9(4), 226–252.

Seppänen O.A., Fisk W.J., 2002. Association of ventilation system type with SBS symptoms in office workers. *International Journal of Indoor Environment and Health*, 12:98-112.

Seppänen O.A, Fisk. W.J., 2002. Association of ventilation system type with SBS symptoms in office workers. , *Indoor Air* 12, 98 – 112

Seppänen O.A., Fisk W.J., 2004. Summary of human responses to ventilation. *Indoor Air*; 14 (Suppl 7): 102–118.

Seppänen O.A., Brelih N., 2011. Ventilation rates and IAQ in European standards and National regulations. AIVC conference Oct 12-13, 2011, Brussels, Belgium

Shendell D.G., Prill R., Fisk W.J., Apte M.G., Blake D., Faulkner D., 2004. Associations between classroom CO₂ concentrations and student attendance in Washington and Idaho. *Indoor air*, 14(5), 333–41.

- Sieber W.K., Stayner L.T., Malkin R., Petersen M.R., Mendell M.J., Wallingford K.M., Crandall M.S., Wilcox T.G. Reed L., 1996. The National Institute for Occupational Safety and Health indoor environmental evaluation experience. Part three: Associations between environmental factors and self - reported health conditions , Applied Occupational and Environmental Hygiene, 11 , 1387 – 1392
- Sundell J., 1982. Guidelines for Nordic building regulations regarding indoor air quality. Environment International Volume 8, Issues 1–6: 17–20.
- Sundell J., Levin H.W., Nazaroff W., Cain W.S., Fisk W.J., Grimsrud D.T., Gyntelberg F., Li Y., Persily A.K., Pickering A.C., Samet J.M., Spengler J.D., Taylor S.T., Weschler C.J., 2011. Ventilation rates and health: multidisciplinary review of the scientific literature. Indoor Air; 21: 191–204.
- Umweltbundesamt, 2002. Recommendations on how to prevent, investigate, evaluate, and eliminate indoor mould growth. German Federal Environmental Agency – Umweltbundesamt. <http://www.umweltdaten.de/publikationen/fpdf-l/4218.pdf>
- Wargocki P., Sundell J., Bischof W., Brundrett G., Fanger P.O., Gyntelberg F., Hanssen S.O., Harrison P., Pickering A., Seppänen O., Wouters P., 2002. Ventilation and Health in Nonindustrial Indoor Environments. Report from a European Multidisciplinary Scientific Consensus Meeting', Indoor Air, 12, 113-128.
- WHO, 1987. Air quality guidelines for Europe. Copenhagen, WHO Regional Office for Europe, 1987 (WHO Regional Publications, European Series, No. 23).
- WHO, 2000. Air quality guidelines for Europe, 2nd ed. Copenhagen, WHO Regional Office for Europe, 2000 (WHO Regional Publications, European Series, No. 91).
- WHO, 2000b. The right to healthy indoor air. Report on a WHO meeting, Bilthoven, Netherlands, 15–17 May 2000. Copenhagen, WHO Regional Office for Europe, 2000.
- WHO, 2006. Air quality guidelines. Global update 2005. Particulate matter, ozone, nitrogen dioxide and sulfur dioxide. Copenhagen, WHO Regional Office for Europe.
- WHO, 2009. WHO guidelines for indoor air quality: dampness and mould. Copenhagen, WHO Regional Office for Europe.
- WHO, 2010. WHO Guidelines for Indoor Air Quality: Selected pollutants. Copenhagen, WHO Regional Office for Europe.

ACKNOWLEDGMENTS

The HealthVent (Health-based ventilation guidelines for Europe) project was supported by a grant from the European Commission's Executive Agency for Health and Consumers (contract no 2009 12 18) and conducted in the period from June 1, 2011 to March 31, 2013.

The project was performed by a consortium composed of eleven associated partners, namely:

- Technical University of Denmark represented by Pawel Wargocki (Coordinator of the project);
- Universitätsklinik Jena, Germany represented by Wolfgang Bischoff and Thomas Hartmann;
- Università degli Studi di Milano, Italy represented by Paolo Carrer, Annaclara Fanetti, and Ezra Mrema;
- National and Kapodistrian University of Athens, Greece represented by Mats Santamouris, Margarita-Niki Assimakopoulou, Maria Salari and Dimosthenes Asimakopoulos;
- Universidade do Porto – Faculdade de Engenharia, Portugal represented by Eduardo de Oliveira Fernandes, Vitor Leal and Hugo Santos;
- National Institute for Health and Welfare in Finland represented by Otto Hänninen, Arja Asikainen and Matti Jantunen;
- Universite de la Rochelle, France represented by Francis Allard;
- Sintef Energi AS, Norway represented by Bjarne Malvik (until May 2012);
- REHVA, Federation of European Heating & Air-conditioning Associations REHVA, Belgium represented by Olli Seppänen, Nejc Brelik and Anita Dyrjanecz;
- Association Asthma, Bulgaria represented by Ted Popov and Tihomir Mustakov;
- EFA, European Federation of Asthma and Allergy Associations, Belgium, represented by Susanna Palkonnen, Roberta Savli, Christine Rolland and David Brennan.

and two collaborative partners, namely:

- WHO, European Centre for Environment and Health in Bonn, Germany represented by Matthias Braubach and Marie-Eve Héroux;
- European Commission, Joint Research Centre, Institute for Health and Consumer Protection, Italy represented by Stylianos Kephelopoulos.

Prof. John D. Spengler from Harvard University, USA and Prof. Jarek Kurnitski from Tallinn University of Technology, Estonia are gratefully acknowledged for providing the evaluation of the project and reviewing the report.

APPENDIXES

APPENDIX 1: Short description of the HealthVent Project

APPENDIX 2: Ventilation typologies

APPENDIX 3: Overview of Standards and Technical Reports on Ventilation in Europe

APPENDIX 4: Members of the ECA “Urban Air, Indoor Environment & Human Exposure” Steering Committee

APPENDIX 1: *Short description of the HealthVent Project*

The HealthVent project (Health-Based Ventilation Guidelines for Europe) was funded in the framework of the Second Programme of Community Action in the Field of Health 2008-2013 with the objective of developing guidelines for health-based ventilation for non-industrial buildings in Europe taking into consideration energy efficiency requirements. The eleven project partners included a multidisciplinary group of experts from: medicine, engineering, indoor air sciences, exposure and risk assessment, energy for thermal comfort, ventilation practices and patient groups associations.

The project was built on the experience, findings and recommendations of: (a) previous projects funded by the European Commission in the field of indoor air quality and health, in particular EnVie and IAIAQ; (b) the Indoor Air Quality Guidelines developed by the World Health Organization; (c) other projects relevant to the topic. The work was carried out in eight work packages of which five were technical work packages (Fig. A1.1).

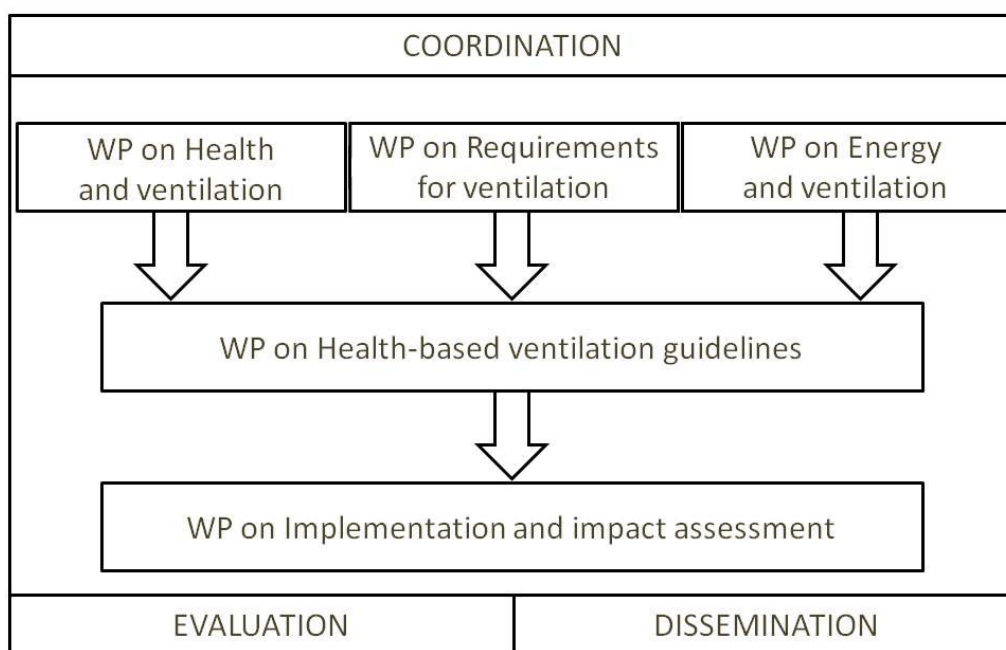

Figure A1. 1. *The structure of the HealthVent project*

Besides the three work packages dealing with the project's coordination and evaluation and dissemination of its results, there were also five technical work packages, which generated the information needed to develop the guidelines. The aim and content of these work packages are summarised in the following:

- The aim of the **work package on ventilation and health** was to retrieve and summarize existing data on the effects of ventilation practices, techniques and rates on indoor air exposures and health. This was accomplished by collecting, surveying and

critically reviewing the data from experimental studies associating ventilation with health, previous reviews and reports on the subject as well as the review of existing guidelines and standards regarding the permissible levels of air contaminants to avoid negative health impacts. Environmental tobacco smoke (ETS) was not considered due to the EU policy for ETS ban indoors in public buildings. Radon was not dealt with either because another EU project running parallel with HealthVent has been specifically addressing this pollutant (RADPAR - on Radon prevention and remediation). Using the collected data, quantitative relationships were established relating health outcomes against ventilation rates.

- The aim of the ***work package on requirements for ventilation*** was to summarize the data on current ventilation regulations and standards, systems, practices and their performance in Europe. Information was retrieved over different EU regions through literature surveys, review of existing ventilation standards, data from Eurostat and national statistics as well as from interviews of experts using a standard questionnaire form. Using the collected data the current situation concerning ventilation of public and residential buildings in Europe was benchmarked in terms of types of ventilation codes and requirements. Data were also collected on how air is delivered through ventilation and about the performance of existing ventilation systems.
- The aim of the ***work package on ventilation and energy*** was to associate existing ventilation strategies and technologies to the energy use in buildings. The work was accomplished by modeling and simulating cases studies of hypothetical buildings under different climatic conditions taking into account different existing ventilation strategies and technologies. Besides creating the relationship between ventilation and energy use, this work package identified and assessed the possibilities to integrate indoor air quality in energy-related inspections and audits.
- The aim the ***work package on health-based ventilation guidelines*** was to create the guidelines' principles and structure considering aspects such as the quality of outdoor air, the performance of ventilation system in relation to air pollutants' exposure, health endpoints and type of the building.
- The aim of the ***work package on implementation and impact assessment*** of the guidelines was to estimate the effects of the implementation of health-based ventilation guidelines/policies on population exposures (and consequently on health using the DALYs approach and risk analysis) and the consequences for energy use (by estimating the need for energy to meet the requirements of the guidelines and comparing them with current and projected energy requirements specified by Building Codes and Energy Codes).

The detailed description of the aforementioned work packages and their publicly available reports on their outcome can be accessed at: www.healthvent.eu (under the folder 'Publications/Work package reports').

APPENDIX 2: Ventilation typologies

Classification of air used for ventilation

The air used for ventilation can be graphically represented according to the diagram shown in Figure A2.1:

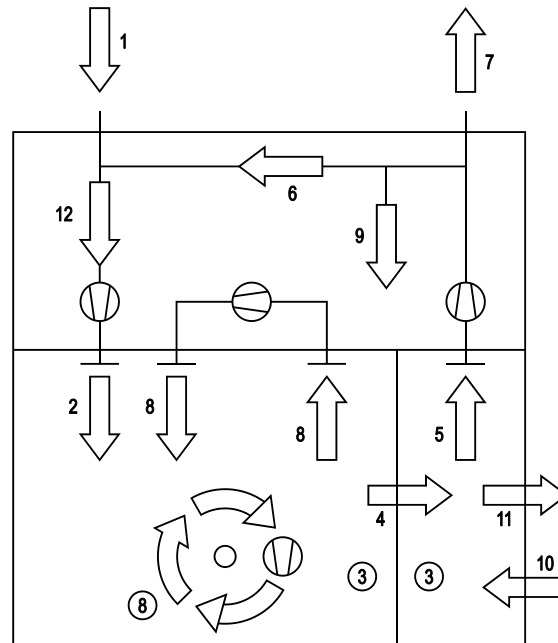

Figure A2.1. Classification of air used for ventilation

1. *Outdoor air* - outdoor air taken outside the building and therefore not previously circulated through the ventilation system;
2. *Infiltration* - the air flowing through the building envelope into the building depending on pressure difference over the structure and the flow paths;
3. *Supply air* - the air supplied to the space after being conditioned (heated, filtered, cooled, humidified or dehumidified); supply air can be 100% from outdoor air or a mixture of recirculated air and outdoor air;
4. *Indoor air* - the air in the ventilated space;
5. *Recirculation air* - a part of extract air, which is not exhausted from the building and after filtering is re-introduced to the ventilated space;
6. *Mixed air* - the mixture of outdoor air and recirculation air;
7. *Extract air* - the air extracted from the space;
8. *Exhaust air* - extract air that is exhausted from the building and not recirculated;
9. *Exfiltration* - the air flowing through the building envelope from inside to outside due the pressure difference;
10. *Secondary air* - the air which is circulated within one space (extracted and supplied) and usually treated during circulation;
11. *Transfer air* - the air moving between adjacent spaces of the building;

12. *Leakage* – unintentional loss of air in the ventilation duct or air handling unit or through the building envelope.

Classification of ventilation systems

The ventilation systems can be classified as depicted in Figure A2. 2:

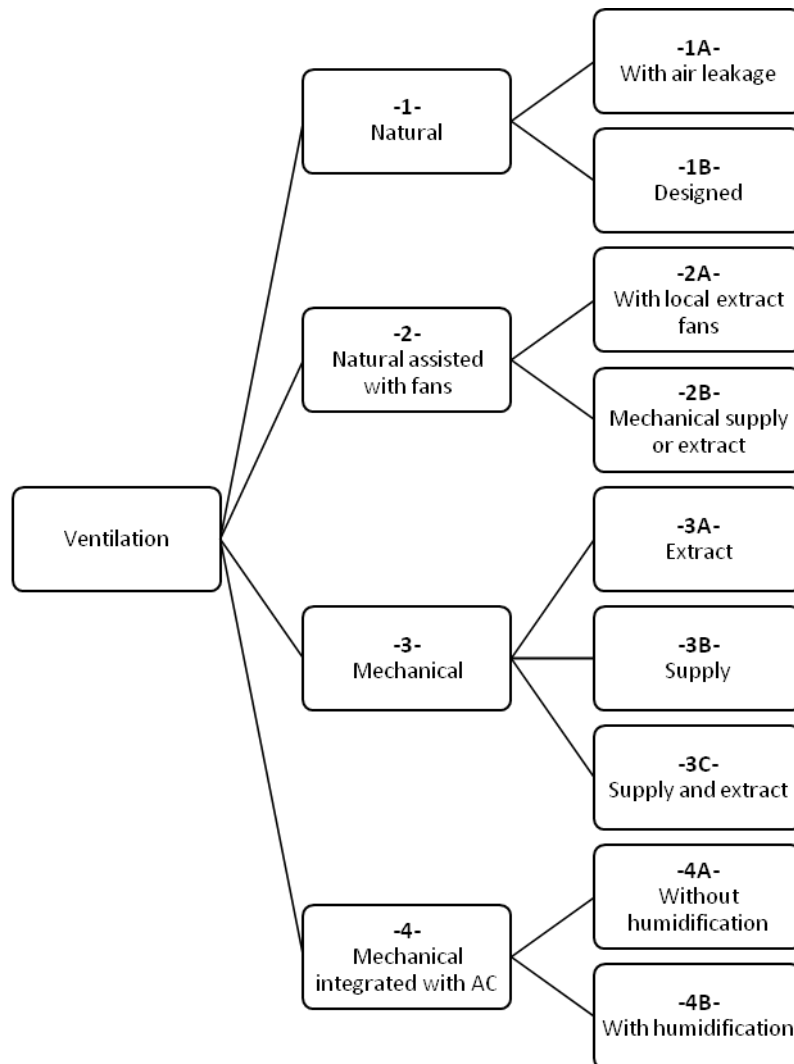

Figure A2.2. *Classification of ventilation systems*

- 1) Natural - in case of natural ventilation the air is supplied to and removed from indoor spaces by natural forces. Ventilation relies entirely on pressure differences.
 - 1A) *Natural, with air leakage* – this system relies solely on infiltration of outdoor air and exfiltration of indoor air. In case of infiltration, the outdoor air flows into the indoor spaces through cracks and other openings in the building envelope and through the normal use of exterior windows and doors. Infiltration and exfiltration are driven by natural and/or artificially produced pressure differences.

- 1B) *Natural, designed* – the ventilation in this system relies also on the pressure difference but unlike in the natural system with air leakage, the openings are especially designed to allow the air to enter the building; the openings can be manually or automatically controlled. The performance of the system usually depends on cross-ventilation or stack-ventilation. In case of the former, the air movement is achieved by creating pressure difference in one level while in case of the latter the vertical lifting forces (buoyancy) is used to move the air.
- 2) Natural assisted with fans – mechanical devices, e.g. small air extract fans, can assist the natural ventilation systems described above. Use of fan is usually intermittent, when pressure differences are insufficient, to achieve the required ventilation rates unlike in the mechanical ventilation systems when fans are usually running continuously (or whenever the ventilation is needed).
- 2A) *Natural assisted with fans, with local extract fans* - in this system, natural ventilation (designed (1B) or with air leakage (1A)) provides ventilation in habitable rooms at all times of the year while extract fans operating intermittently increase ventilation when needed (e.g., during cooking, bathing or laundry drying) and only locally (in spaces where mounted).
- 2B) *Natural assisted with fans, mechanical supply or extract (for intermittent operation)* - this system operates as natural ventilation system for most part of the year, but it is additionally equipped with fan which increase ventilation at times when natural forces are insufficient to support ventilation; the fans support ventilation for the entire indoor air volume and not only locally like in case of the system described in (2A).
- 3) Mechanical - these systems rely on mechanical devices, which intentionally supply the air to and exhaust it from the building. Infiltration and exfiltration by natural forces can still occur in these systems. However, the ventilation depends entirely on the designed mechanical system with fans used to move the air. The system can be centralized, i.e. serving the entire building, or decentralized (local), i.e. serving only a certain room or group of rooms. The supply air in these systems is filtered and heated; often the systems are equipped with heat recovery systems to recover the heat from extract air. The systems can be designed to recirculate the exhaust air.
- 3A) *Mechanical, extract* – this system relies on mechanical forces; a fan extracts the air from rooms to outdoors usually through a specially design duct system or through shafts. Outdoor air enters the indoor space through specially designed slots and air openings; it is not treated. Mechanical exhaust ventilation system can serve one room, apartment or whole building (decentralized or central system).
- 3A) *Mechanical, supply* – this system relies on mechanical forces; a fan supplies the air to indoor spaces; the air is extracted through specially designed openings in building envelope. The supplied air is usually heated and filtered.
- 3C) *Mechanical, supply and extract* – these systems combine the two systems described above. These are balanced systems in which there is a supply and exhaust fan assuring that supply and exhaust flows are similar. They provide treatment of supply air: heating and filtering, and can be with heat recovery systems. These systems can also recirculate part of the air exhausted from the rooms.

- 4) Mechanical integrated with air-conditioning (AC) – these systems have similar features as the mechanical ventilation system described above though they provide full conditioning of the supplied air including humidification or dehumidification and mechanical cooling. Two subcategories include systems without humidification (4A) and with humidification (4B).

Besides the systems described above there can also be mixed-mode (hybrid) systems. These systems combine the features of the designed natural ventilation system and mechanical ventilation system either with exhaust or with supply and exhaust. In case of favorable conditions, natural forces are used to ensure required ventilation; otherwise, the mechanical system is used to ensure that the designed ventilation requirements are met.

APPENDIX 3: Overview of Standards and Technical Reports on Ventilation in Europe

STANDARDS AND TECHNICAL REPORTS DIRECTLY RELATED TO INDOOR AIR QUALITY		1/3
CR 1752: 1998	<i>Ventilation for buildings - Design criteria for the indoor environment</i>	
<p>This Technical Report specifies the requirements for, and methods of expressing the quality of the indoor environment for the design, commissioning, operation and control of ventilation and air-conditioning systems. This report does not have a status of a standard but has relevant information on indoor air quality and climate. This Technical Report covers indoor environments where the major concern is the human occupation but excludes dwellings. It does not cover buildings where industrial processes or similar operations requiring special conditions are undertaken. The practical procedures, including selection of parameters to be measured during commissioning, control and operation, are not covered.</p>		
EN 15251: 2007	<i>Indoor environmental input parameters for design and assessment of energy performance of buildings addressing indoor air quality, thermal environment, lighting and acoustics</i>	
<p>This European Standard specifies the indoor environmental parameters that have an impact on the energy performance of buildings. - The standard specifies how to establish indoor environmental input parameters for building system design and energy performance calculations. The values of indoor environmental parameters in this standard are based on CR 1752 and other earlier published standards. - The standard specifies methods for long-term evaluation of the indoor environment obtained as a result of calculations or measurements. - The standard specifies criteria for measurements, which can be used if required to measure compliance by inspection. - The standard identifies parameters to be used by monitoring and displaying the indoor environment in existing buildings. This standard is applicable mainly in non-industrial buildings where the criteria for indoor environment are set by human occupancy and where the production or process does not have a major impact on indoor environment. The standard is thus applicable to the following building types: single family houses, apartment buildings, offices, educational buildings, hospitals, hotels and restaurants, sports facilities, wholesale and retail trade service buildings. - The standard specifies how different categories of criteria for the indoor environment can be used. But does not require certain criteria to be used. This is up to national regulations or individual project specifications. - The recommended criteria in this standard can also be used in national calculation methods, which may be different to the methods referred to here. - The standard does not prescribe design methods, but give input parameters to the design of buildings, heating, cooling, ventilation and lighting systems - The standard does not include criteria for local discomfort factors like draught, radiant temperature asymmetry, vertical air temperature differences and floor surface temperatures.</p>		
EN 13779: 2007	<i>Ventilation for non-residential buildings - Performance requirements for ventilation and room-conditioning systems</i>	
<p>This European Standard applies to the design and implementation of ventilation and room conditioning systems for non-residential buildings subject to human occupancy, excluding applications like industrial processes. It focuses on the definitions of the various parameters that are relevant for such systems. The guidance for design given in this standard and its annexes are mainly applicable to mechanical supply and exhaust ventilation systems, and the mechanical part of hybrid ventilation systems. Applications for residential ventilation are not dealt with in this standard. CEN/TR 14788 is dealing with the performance of ventilation systems in residential buildings. The classification uses different categories. For some values, examples are given and, for requirements, typical ranges with default values are presented. The default values given in this standard are not normative as such, and should be used where no other values are specified. Classification should always be appropriate to the type of building and its intended use, and the basis of the classification should be explained if the examples given in the standard are not to be used. NOTE Different standards may express the categories for the same parameters in a different way, and also the category symbols may be different.</p> <p>The general part of the standard includes chapters on terms and definitions and symbols and units. The main chapters of the standard are Agreement of design criteria, Classification, Indoor environment and annexes. Agreement of design criteria specifies the information needed to design the system. The criteria provide the common language between all the parties in the design and construction process and specify which issues must be agreed before or during the design process to avoid discrepancies between parties involved in the construction process. The classification provides specification of types of air, classification of air, system tasks and basic system types, pressure conditions in the room, specific fan power and heat recovery.</p> <p>The chapter on Indoor environment defines design assumptions for the occupied zone, thermal environment, indoor air quality, indoor air humidity and acoustic environment. The section on indoor air quality provides typical values for human occupancy and recommends that emissions from sources other than human metabolism and smoking shall be specified as clearly as possible. For supply air flow rates it instructs to use ventilation rates as defined in EN 15251:2007.</p>		
CEN/TR 14788: 2006	<i>Ventilation for buildings - Design and dimensioning of residential ventilation systems</i>	
<p>This Technical Report specifies recommendations for the performance and design of ventilation systems serving single family, multi-family and apartment type dwellings during both summer and winter. It is of particular interest to architects, designers, builders and those involved with implementing national, regional and local regulations and standards.</p> <p>Four basic ventilation strategies are covered: natural ventilation; fan assisted supply air ventilation; fan assisted exhaust air ventilation; fan assisted balanced air ventilation.</p>		

STANDARDS AND TECHNICAL REPORTS DIRECTLY RELATED TO INDOOR AIR QUALITY		2/3
<p>Combinations of these systems are not excluded and a ventilation system may serve only one dwelling (individual system) or more than one dwelling (central system). The ventilation aspects of combined systems (ventilation with heating and/or cooling) are covered. The ventilation of garages, common spaces, roof voids, sub-floor voids, wall cavities and other spaces in the structure, under, over or around the living space are not covered.</p>		
EN 12097: 2006	<i>Ventilation for Buildings - Ductwork - Requirements for ductwork components to facilitate maintenance of ductwork systems</i>	
<p>This European standard specifies requirements for dimension, shape and location for access panels for cleaning and service in ductwork systems, which conform to EN 1505, EN 1506 and EN 13180. National regulations shall always be followed, even when they deviate from requirements given in this standard.</p>		
EN 13053: 2006	<i>Ventilation for buildings - Air handling units - Ratings and performance for components and sections</i>	
<p>This European Standard specifies requirements and testing for ratings and performance of air handling units as a whole. It also specifies requirements, recommendations, classification, and testing of specific components and sections of air handling units. For many components and sections it refers to component standards, but it also specifies restrictions or applications of standards developed for standalone components. This standard is applicable both to standardised designs, which may be in a range of sizes having common construction concepts, and also to custom-design units. It also applies both to air handling units, which are completely prefabricated, and to units which are built up on site. Generally the units within the scope of this standard include at least a fan, a heat exchanger and an air filter. This standard is not applicable to the following: a) air conditioning units serving a limited area in a building, such as fan coil units; b) units for residential buildings; c) units producing ventilation air mainly for a manufacturing process.</p>		
EN 15239: 2007	<i>Ventilation for buildings - Energy performance of buildings - Guidelines for inspection of ventilation systems</i>	
<p>This standard develops the methodology required for the inspection of mechanical and natural ventilation systems in relation to its energy consumption. This standard applies to both residential and non-residential buildings. The inspection may include the following issues, in order to determine the energy performance of the building and its associated mechanical / electrical plant: - The system conformity related to the original and subsequent design modifications, actual requirements and the present building state. - Correct operation of the mechanical, electrical or pneumatic components. - Provision of an adequate and pure supply of ventilation air. - The functioning of all the controls involved. - Fan power absorbed and specific fan power. - Building air tightness. It is not the intention of the standard to provide a full ventilation system audit. Its purpose is to assess its functioning and its impact on energy consumption. It includes recommendations on possible system improvements. NOTE The inspection, performed by an independent person to assess the system performance relating to energy consumption, is different from the maintenance that is performed to the owner's requirements to maintain the optimum system performance. The standard insists on the fact that one of the results of the inspection shall be a list of proposals necessary to improve its energy efficiency. The list shall contain among others a list of adjustments to be made to ensure that it agrees with the design i.e. correct levels of thermal comfort, IAQ and energy usage.</p>		
EN 15240: 2007	<i>Ventilation for buildings - Energy performance of buildings - Guidelines for inspection of air conditioning systems</i>	
<p>This European Standard describes the common methodology for inspection of air conditioning systems in buildings for space cooling and or heating from an energy consumption standpoint. The inspection can consider for instance the following points to assess the energy performance and proper sizing of the system: - System conformity to the original and subsequent design modifications, actual requirements and the present state of the building. - Correct system functioning. - Function and settings of various controls. - Function and fitting of the various components. - Power input and the resulting energy output. It is not intended that a full audit of the air conditioning system is carried out, but a correct assessment of its functioning and main impacts on energy consumption, and as a result determine any recommendations on improvement of the system or use of alternative solutions. National regulations and guidelines targeting energy efficiency and in line with the main objectives of this standard are also applicable. NOTE Provision of adequate ventilation and system balancing are dealt with in EN 15239. The qualification of the persons or organisation responsible for inspections is not covered by this standard, but the requirements for inspections are covered. The frequency of the mandatory inspection is defined on national level. Features affecting the frequency and duration of inspection are introduced in Annex C.</p>		
EN 15665: 2009	<i>Ventilation for buildings - Determining performance criteria for design of residential ventilation systems</i>	
<p>This European Standard sets out criteria to assess the performance of residential ventilation systems (for new, existing and refurbished buildings) which serve single family, multi-family and apartment type dwellings throughout the year. This European Standard specifies ways to determine performance criteria to be used for design levels in regulations and/or standards. These criteria are meant to be applied to, in particular: - mechanically ventilated building (mechanical exhaust, mechanical supply or balanced system); - natural ventilation with stack effect for passive ducts; - hybrid system switching between mechanical and natural modes; - windows opening by manual operation for airing or summer comfort issues. This European Standard considers aspects of hygiene and indoor air quality. Health risk from exposure to tobacco smoke is excluded from this European Standard.</p>		

STANDARDS AND TECHNICAL REPORTS DIRECTLY RELATED TO INDOOR AIR QUALITY		3/3
prEN 15780: 2008	<i>Ventilation for buildings - Ductwork - Cleanliness of ventilation systems</i>	
<p>This European Standard applies to both new and existing ventilation and air conditioning systems and specifies the assessment criteria of cleanliness, cleaning procedures of these systems, and the validation of the effectiveness of cleaning applies also to products, which conform to EN 1505, EN 1506, EN 13053, EN 13180 and EN 13403, used in air conditioning and ventilation systems for human occupancy defined in the scope of CEN/TC 156. This European Standard does not apply to installations for industrial processes. Cleanliness of ventilation systems is considered important for human comfort and health, energy consumption, system service life and for cleanliness of operations or processes carried out in the ventilated area. Considerations for change of component as an alternative for cleaning (e.g. in case of flexible ducts and air filters) are also included. This European Standard specifies general requirements and procedures necessary in assessing and maintaining the cleanliness of ducted ventilation, including: - cleanliness quality classification; - how to assess the need for cleaning (visual, measurements); - assessment frequency (general guidance); guidance of system inspections in accordance with EN 15239, and EN 15240 when relevant; - selection of cleaning method - to be in line with handing over documentation according to EN 12599; - how to assess the result of cleaning. This European Standard is a parallel standard to EN 12097, which specifies requirements for dimension, shape and location for access panels for cleaning and service in ductwork systems.</p>		
EN 15243: 2007	<i>Ventilation for buildings - Calculation of room temperatures and of load and energy for buildings with room conditioning systems</i>	
<p>The scope of this European Standard is - To define the procedure how the calculation methods to determine the temperatures, sensible loads and energy demands for the rooms shall be used in the design process. - To describe the calculation methods to determine the latent room cooling and heating load, the building heating, cooling, humidification and dehumidification loads and the system heating, cooling, humidification and dehumidification loads. - To define the general approach for the calculation of the overall energy performance of buildings with room conditioning systems - To describe one or more simplified calculation methods for the system energy requirements of specific system types, based on the building energy demand result from prEN ISO 13790, and to define their field of application. A general framework standard is given which imposes an hourly calculation for all cases, which cannot be covered by simplified methods, and gives requirements on what has to be taken into account. Input and output data are defined. The target audience of this standard is twofold: - Designers of HVAC systems, which are given an overview of the design process with the relevant references to the different involved standards (Clauses 5 to 12) - Developers of regulations and tools, which find requirements for calculation procedures to be used for the energy requirements according to the EPBD (Clauses 13 and 14). The idea followed by this standard is, that for the detailed approach one single calculation method is used for the different room related purposes such as room temperature calculation, room cooling and heating load calculation, and room energy calculation. This means, for the building type envisaged (buildings with room conditioning systems) it is an alternative to simplified calculation methods such as heating load according to EN 12831 and heating energy according to prEN ISO 13790.</p>		
FprEN 779: 2011	<i>Particulate air filters for general ventilation - Determination of the filtration performance</i>	
<p>This European Standard refers to particulate air filters for general ventilation. These filters are classified according to their performance as measured in this test procedure. This European Standard contains requirements to be met by particulate air filters. It describes testing methods and the test rig for measuring filter performance. In order to obtain results for comparison and classification purposes, particulate air filters should be tested against two synthetic aerosols, a fine aerosol for measurement of filtration efficiency as a function of particle size within a particle size range 0.2 µm to 3.0 µm, and a coarse one for obtaining information about dust holding capacity and, in the case of coarse filters, filtration efficiency with respect to coarse loading dust (arrestance). This European Standard applies to air filters having an initial efficiency of less than 98 % with respect to 0.4 µm particles. Filters should be tested at an air flow rate between 0.24 m³/s (850 m³/h) and 1.5 m³/s (5400 m³/h). The performance results obtained in accordance with this standard cannot be applied quantitatively on its own to predict performance in service with regard to efficiency and lifetime. Other factors influencing performance to be taken into account are described in Annex A (Normative) and Annex B (Informative).</p>		

STANDARDS DEALING WITH TECHNICAL ASPECTS OF VENTILATION	
EN ISO 7730: 2006	Ergonomics of the thermal environment - Analytical determination and interpretation of thermal comfort using calculation of the PMV and PPD indices and local thermal comfort criteria (ISO 7730:2005)
EN 12237: 2003	Ventilation for buildings - Ductwork - Strength and leakage of circular sheet metal ducts
EN 12239: 2001	Ventilation for buildings - Air terminal devices - Aerodynamic testing and rating for displacement flow applications
EN 12599: 2001	Ventilation for buildings - Test procedures and measuring methods for handing over installed ventilation and air conditioning systems
EN 12792: 2003	Ventilation for buildings - Symbols, terminology and graphical symbols
EN 13141-1: 2004	Ventilation for buildings – Performance testing of components/products for residential ventilation. Part 1: Externally and internally mounted air transfer devices
EN 13141-2: 2010	Part 2: Exhaust and supply air terminal devices
EN 13141-3: 2004	Part 3: Range hoods for residential use
EN 13141-4: 2004	Part 4: Fans used in residential ventilation systems
EN 13141-5: 2004	Part 5: Cowls and roof outlet terminal devices
EN 13141-6: 2004	Part 6: Exhaust ventilation system packages used in a single dwelling
EN 13141-7: 2010	Part 7: Performance testing of a mechanical supply and exhaust ventilation units (including heat recovery) for mechanical ventilation systems intended for single family dwellings
EN 13141-8: 2006	Part 8: Performance testing of un-ducted mechanical supply and exhaust ventilation units (including heat recovery) for mechanical ventilation systems intended for a single room
EN 13141-9: 2008	Part 9: Externally mounted humidity controlled air transfer device
EN 13141-10: 2008	Part 10: Humidity controlled extract air terminal device
EN 13142: 2004	Ventilation for buildings – Components/products for residential ventilation – Required and optional performance characteristics
EN 13182: 2002	Ventilation for buildings - Instrumentation requirements for air velocity measurements in ventilated spaces
EN 14134: 2004	Ventilation for buildings - Performance testing and installation checks of residential ventilation systems
EN 15241: 2007	Ventilation for buildings – Calculation methods for energy requirements due to ventilation systems in buildings
EN 15242: 2007	Ventilation for buildings - Calculation methods for the determination of air flow rates in buildings including infiltration
EN 15243: 2007	Ventilation for buildings - Calculation of room temperatures and of load and energy for buildings with room conditioning systems
EN 15727: 2010	Ventilation for buildings – Ducts and ductwork components, leakage classification and testing.
EN 15650: 2010	Ventilation for buildings - Fire dampers
EN 15871: 2009	Ventilation for buildings - Fire resisting duct sections

VENTILATION STANDARDS CLASSIFIED ACCORDING TO THEIR PURPOSE

Purpose of EN standard	Building type	
	Residential	Non residential
Criteria for indoor environment	EN 15251:2007	
Design and dimensioning of ventilation systems	CEN/TR 14788:2006	EN 13779:2007
Determining performance criteria of residential ventilation systems	EN 15665:2009	
Calculation of ventilation rates	EN 13465:2004	EN 15242:2007
Calculation of ventilation energy	EN 15241:2007	
Rating and performance characteristics	prEN 13142 Rev V7 on components/products for residential ventilation	EN 13052:2006 on air handling units
Performance testing of components and products	EN 13141-1 /air transfer devices EN 13141-2 /exh. & supply air terminal devices EN 13141-4 /fans EN 13141-5 /cowls and roof outlets EN 13141-6 /exh. ventilation system packages EN 13141-7 /mech. supply & exh. units + HR for dwellings EN 13141-8 /mech. supply & exh. units + HR for rooms EN 13141-9 /ext. mounted RV-controlled air transf. device EN 13141-10 /hum. controlled extract air terminal device	EN 1886:2007 /Mech. performance air handling units ISO 5801:1997 /Industrial fans performance testing ISO 12248 /Ind. fans tolerances & conversion methods ISO 5221 /Acoustics, in duct radiated sound power level ISO 5213 /Acoustics, casing radiated sound power level EN 1751 /Aerodynamic testing of dampers & valves EN 1216 /Performance testing heating/cooling coils EN 779 /Determination of filtration performance EN 308 / Performance testing air-to-air HR-devices

APPENDIX 4: Members of the ECA “Urban Air, Indoor Environment & Human Exposure” Steering Committee

AUSTRIA

Hans **MOSHAMMER**, Medical University of Wien, Wien

Peter **TAPPLER**, Innenraumanalytik, Wien

Maria **UHL**, Austrian Environment Agency, Wien

BELGIUM

Dieter **DE LATHAUWER**, Federal Public Service - Public Health, SFC and Environment, Brussels

Eddy **GOELEN**, VITO, Mol

Marianne **STRANGER**, VITO, Mol

Fabrice **THIELEN**, Federal Public Service - Public Health, SFC and Environment, Brussels

Peter **WOUTERS**, Belgian Building Research Institute, Brussels

DENMARK

Geo **CLAUSEN**, Technical University of Denmark, Lyngby

Torben **SIGSGAARD**, Aarhus University, Aarhus

Pawel **WARGOCKI**, Technical University of Denmark, Lyngby

Thomas **WITTERSEH**, Technical University of Denmark, Lyngby

Peder **WOLKOFF**, National Research Centre for the Working Environment, Copenhagen

FINLAND

Otto **HÄNNINEN**, National Public Health Institute, Kuopio

Matti **JANTUNEN**, National Public Health Institute, Kuopio

Jorma **SÄTERI**, FiSIAQ, Helsinki

FRANCE

Severine **KIRCHNER**, Building Research Institute (CSTB), Champs-sur-Marne

Corinne **MANDIN**, Building Research Institute (CSTB), Champs-sur-Marne

Françoise **MAUPETIT**, Building Research Institute (CSTB), Champs-sur-Marne

Christophe **ROUSSELLE**, French Agency for Food, Environmental and Occupational Health & Safety (ANSES), Paris

GERMANY

Christine **DÄUMLING**, Federal Environment Agency (UBA), Berlin

Birger **HEINZOW**, LAsD, Germany

GREECE

John **BARTZIS**, University of West Macedonia, Kozani

Matheos **SANTAMOURIS**, National & Kapodistrian University of Athens, Athens

HUNGARY

Eva **CSOBOD**, Regional Environmental Centre, Budapest

IRELAND

James P. **McLAUGHLIN**, University College Dublin, Dublin

ITALY

Francesco **BOCHICCHIO**, Istituto Superiore di Sanità, Roma

Paolo **CARRER**, Milan University, Milan

LUXEMBOURG

Ralf **BADEN**, Ministry of Health, Luxembourg

THE NETHERLANDS

Bert **BRUNEKREEF**, Utrecht University, Utrecht

Cornelus J.M. **VAN DEN BOGAARD**, Ministry of Infrastructure and Environment, The Hague

Tom van **TEUNENBROEK**, Ministry of Infrastructure and Environment, The Hague

NORWAY

Jan **HONGSLO**, National Institute of Public Health, Oslo

Sten Olaf **HANSSEN**, Norwegian University of Science and Technology, Trondheim

PORTUGAL

Eduardo de **OLIVEIRA FERNANDES**, University of Porto, Porto

SWEDEN

Gunnar **JOHANSON**, Karolinska Institute, Stockholm

Greta **SMEDJE**, University Hospital, Uppsala

SWITZERLAND

Christian **MONN**, State Secretariat for Economic Affairs (SECO), Work and Health, Zürich

UNITED KINGDOM

Derrick **CRUMP**, IEH, Cranfield University, Cranfield

Paul T. **HARRISON**, PTCH Consultancy, Market Harborough

WHO

Mattias **BRAUBACH**, WHO, European Centre for Environment and Health, Bonn

Marie Eve **HÉROUX**, WHO, European Centre for Environment and Health, Bonn

EUROPEAN COMMISSION

Stylios **KEPHALOPOULOS** (*Scientific Co-ordinator*), Joint Research Centre, Ispra

GETTING IN TOUCH WITH THE EU

In person

All over the European Union there are hundreds of Europe Direct information centres. You can find the address of the centre nearest you at: https://europa.eu/european-union/contact_en

On the phone or by email

Europe Direct is a service that answers your questions about the European Union. You can contact this service:

- by freephone: 00 800 6 7 8 9 10 11 (certain operators may charge for these calls),
- at the following standard number: +32 22999696, or
- by electronic mail via: https://europa.eu/european-union/contact_en

FINDING INFORMATION ABOUT THE EU

Online

Information about the European Union in all the official languages of the EU is available on the Europa website at: https://europa.eu/european-union/index_en

EU publications

You can download or order free and priced EU publications from EU Bookshop at: <https://publications.europa.eu/en/publications>. Multiple copies of free publications may be obtained by contacting Europe Direct or your local information centre (see https://europa.eu/european-union/contact_en).

The European Commission's science and knowledge service

Joint Research Centre

JRC Mission

As the science and knowledge service of the European Commission, the Joint Research Centre's mission is to support EU policies with independent evidence throughout the whole policy cycle.



EU Science Hub

ec.europa.eu/jrc



@EU_ScienceHub



EU Science Hub - Joint Research Centre



EU Science, Research and Innovation



EU Science Hub



Publications Office
of the European Union

doi:10.2788/17476

ISBN 978-92-79-54143-8