



Calhoun: The NPS Institutional Archive
DSpace Repository

Faculty and Researchers

Faculty and Researchers' Publications

2006-06-01

Rapid Response Command and Control SEA Integrated Project

Sullivan, Lisa

<http://hdl.handle.net/10945/59804>

This publication is a work of the U.S. Government as defined in Title 17, United States Code, Section 101. Copyright protection is not available for this work in the United States.

Downloaded from NPS Archive: Calhoun



Calhoun is the Naval Postgraduate School's public access digital repository for research materials and institutional publications created by the NPS community. Calhoun is named for Professor of Mathematics Guy K. Calhoun, NPS's first appointed -- and published -- scholarly author.

Dudley Knox Library / Naval Postgraduate School
411 Dyer Road / 1 University Circle
Monterey, California USA 93943

<http://www.nps.edu/library>



Rapid Response Command and Control SEA Integrated Project

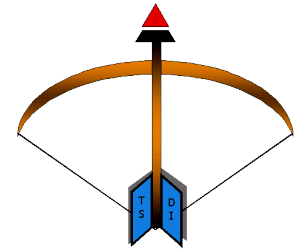

1 June 2006



Introduction and Systems Engineering Process

LCDR Lisa Sullivan



Agenda

0745-0800	Refreshments ME Aud	
0800-1000 ME Aud	R2C2 Final Presentation	
-0850-0900	Break	
1000-1100 100C	Model Demonstration	Bu
1100-1200	Lunch Break	



Outline

- Systems Engineering Process
- Summary of Results
- Mission Analysis
- Requirements
- Architectures
- Information Assurance
- Modeling
- System Analysis
- Conclusions



Exceeded Educational Expectations

- Completed rigorous Systems Engineering Process to design system architectures
- Fully integrated with Temasek Defense Science Institute students and collaborated with multiple research entities cross campus
- Thoroughly researched strategic publications and current operations' lessons learned to capture joint capability gaps
- Built strong relationships with stakeholders to ensure timely and accurate feedback on project progression and system design
- Learned in depth about new technical areas



R2C2 Organization

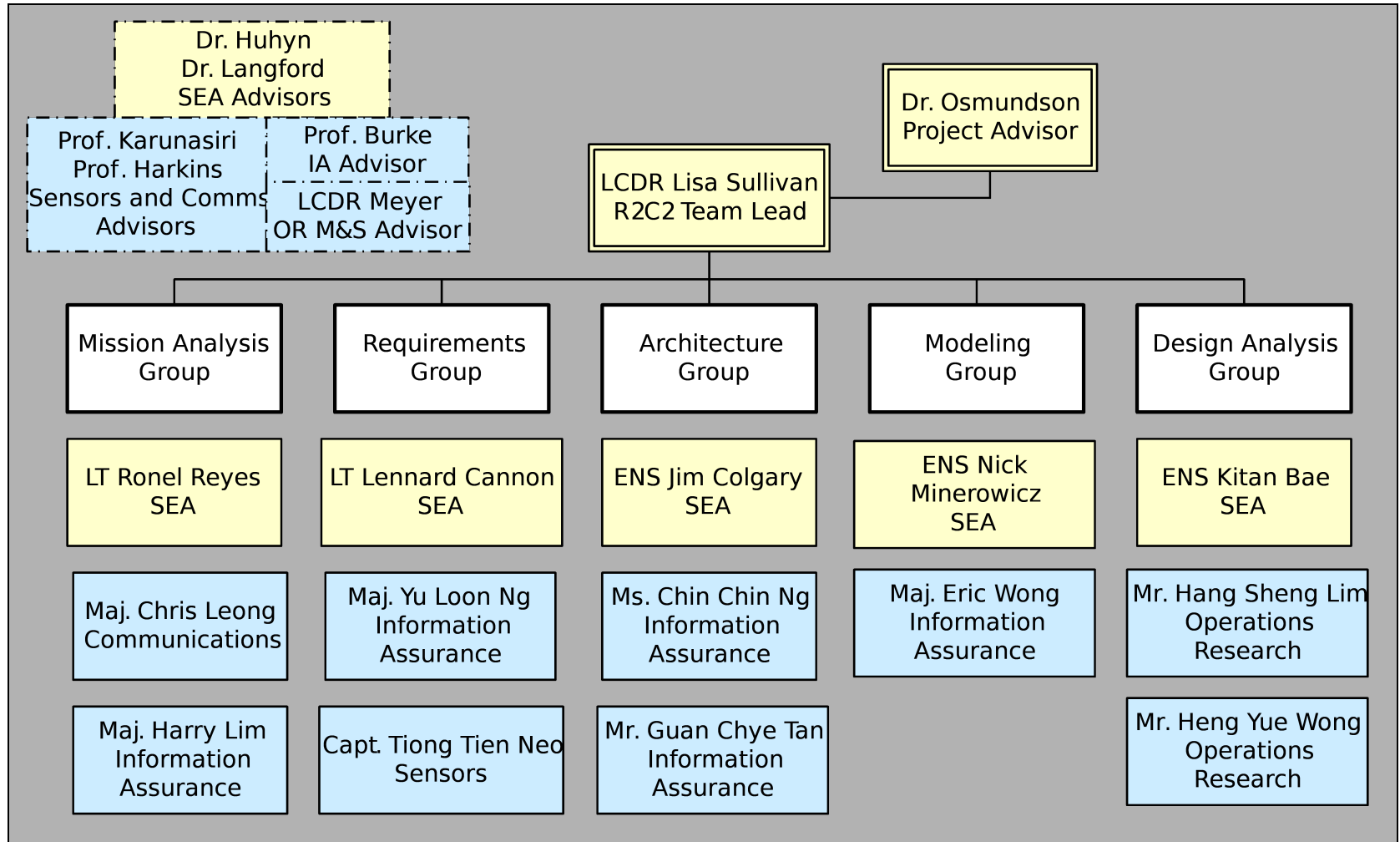

SEA Students and Advisors

TDSI Students and Advisors



Stakeholders

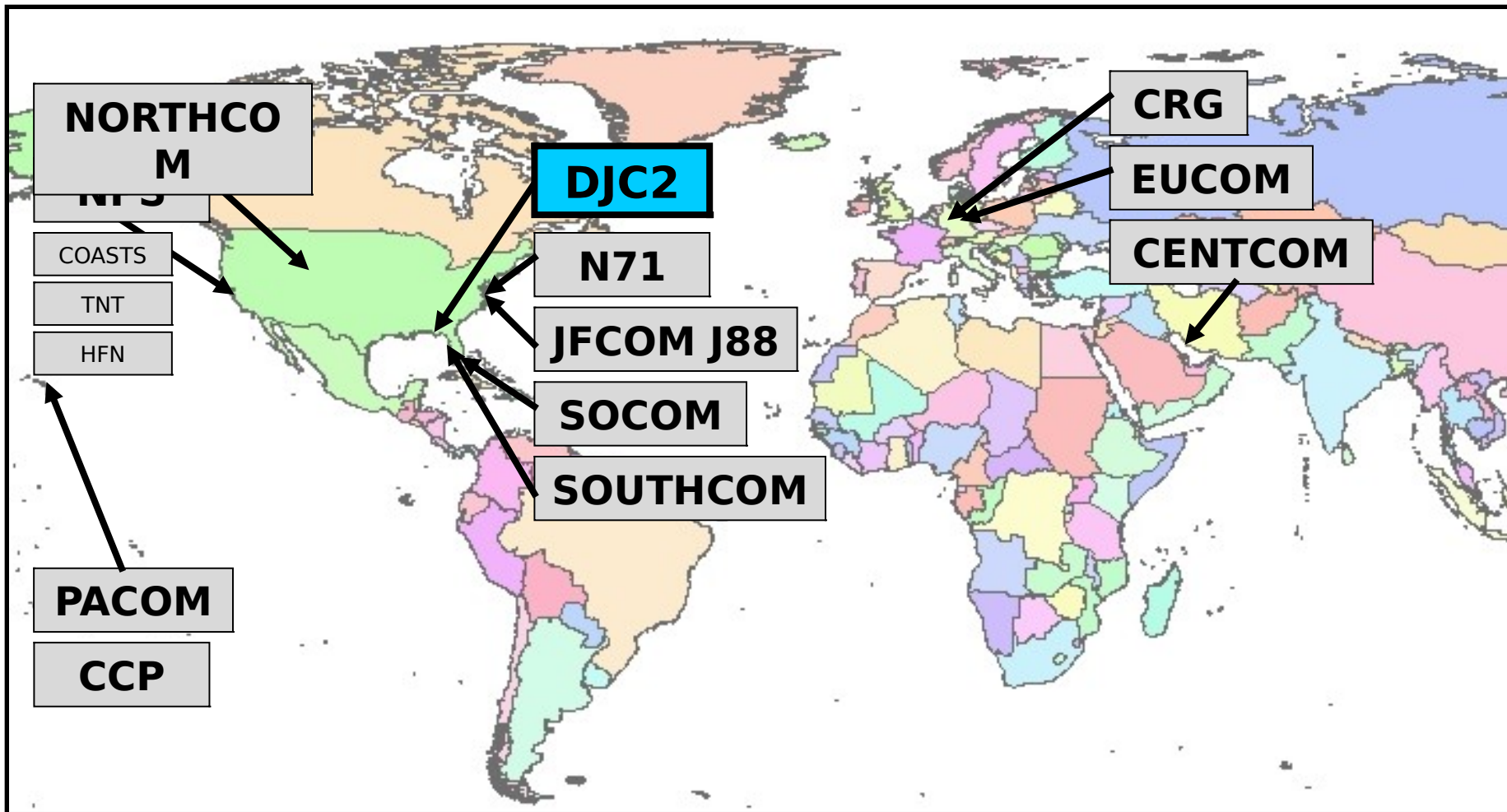



Systems Engineering Approach

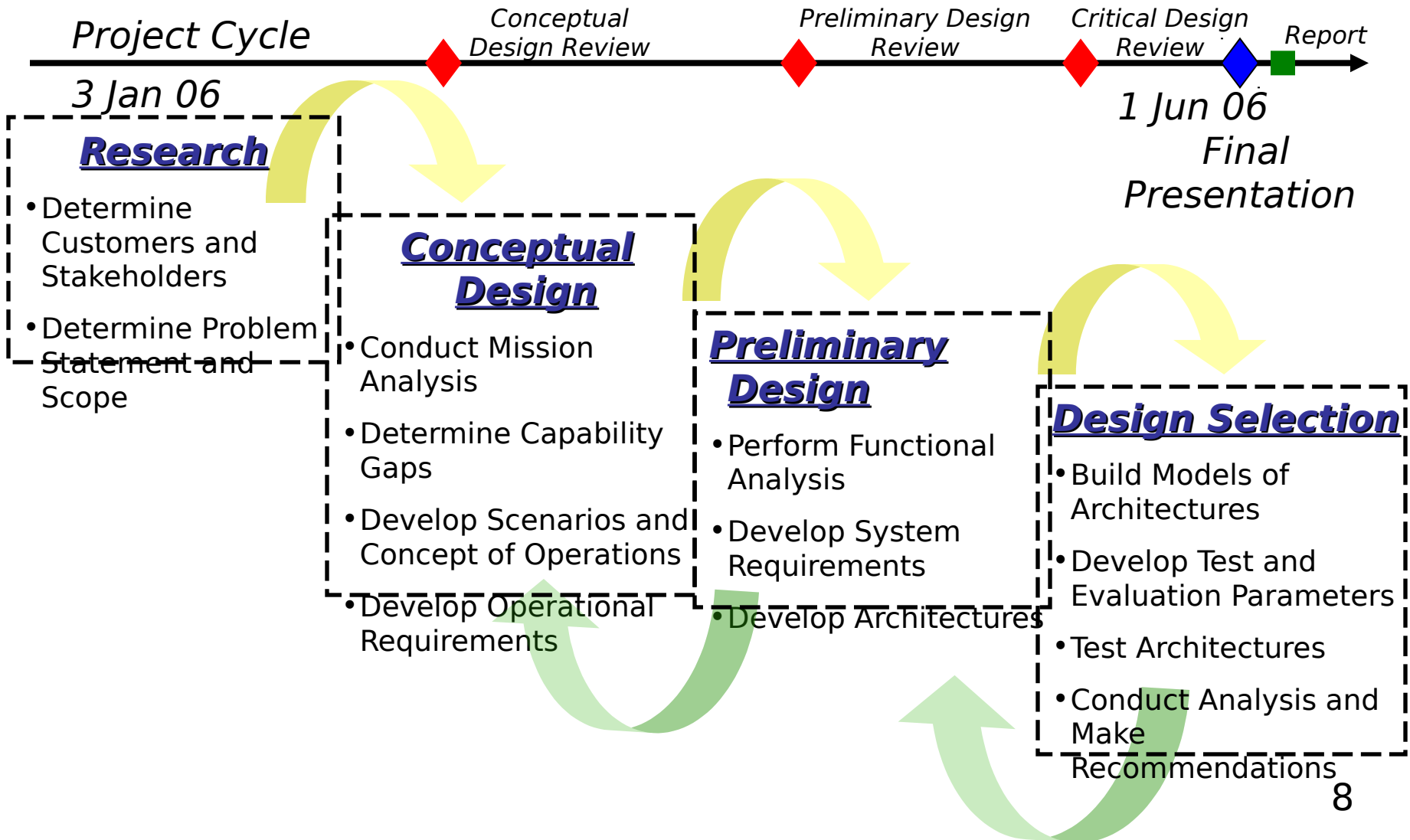



Problem Statement

Develop and analyze architectures, and design systems for a rapidly deployable, command and control system to provide Regional Combatant Commanders initial situational awareness and communication capabilities through the range of military operations.



Architecture Overview (1)

Primary Suite

Provides Reachback
to the Regional
Combatant
Commanders and the
Global Information
Grid



**Routers
Switches**



Generator



Laptops



**Satellite
Terminal**



Phones



**Encryption
Devices**



Architecture Overview (2)

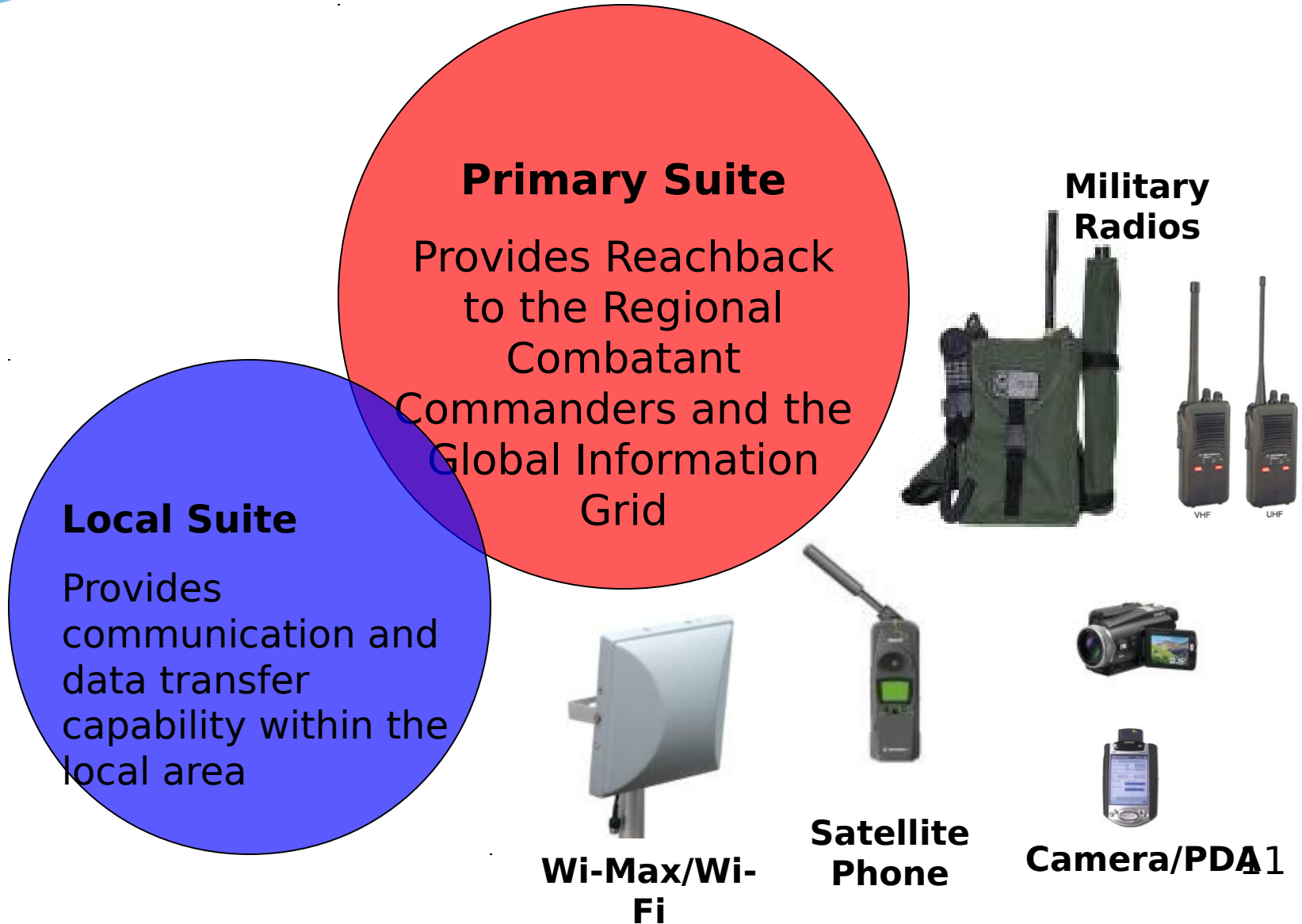



Architecture Overview (3)



Laptops



Satellite Terminal

Primary Suite

Provides Reachback to the Regional Combatant Commanders and the Global Information Grid

Grid



Local Suite

Provides communication and data transfer capability within the local area



Civilian/Military Suite

Provides internet access for the Civil Military Operating Centers during HA/DR



Project Results (1)

- Addressed the challenge of multiple users in varying environments
 - Developed five scenarios that cover the Range of Military Operations
 - Received feedback and approval of scenarios
- Utilized a top down approach for developing requirements
 - Developed operational requirements based on capability need
 - Conducted Function Analysis to develop system requirements and traced to strategic guidance
 - Identified additional requirements based on Mission Analysis: Organic Power, Local Communications, and Civilian/Military Link



Project Results (2)

- Researched and analyzed over 40 options for architectures
 - Conducted market surveys and reduced selection to 8 potential architectures
 - Focused on developing modular suites to define architectures: Primary Suite, Local Suite, and Civil/Military Suite
- Captured architecture performance through multiple models
 - Determined transmission time decreases by 50 minutes with dedicated data link
 - Determined sufficient bandwidth, over 50%, to support integrated CMS
 - Conducted capability vs weight tradeoffs and determined data link capability incurred 50 extra pounds per scout team
 - Determined final architectures were dependent on type



Project Results (3)

- Utilized multiple decision aids to compare as-is systems, proposed system, and R2C2
 - Conducted Analytic Hierarchy Process to rate critical operational issues
 - Conducted separate stop light comparison of systems to requirements generated by the team and outlined in the Capabilities Production Document and Broad Area Announcement

	AHP	Traffic light matrix
R2C2	42.7%	27/28
Proposed	28.3%	22/28
As-Is	29.0%	16/28

Due to modular design, R2C2 system outperformed proposed and as-is systems



Mission Analysis

LT Ronel Reyes

Maj. Chris Leong

Maj. Harry Lim



Mission Analysis Outline

- Characteristics of R2C2 system
- Research conducted
- Needs analysis / capability gaps
- Range of military operations
 - Five scenarios
 - Scenario stress matrix
- Feedback from stakeholders



Characteristics of R2C2 (1)

2 Categories - System owner and System operator

- Defining the R2C2 system requirement
 - 4 perspectives were identified
 - Demands and limitations from each system

perspective were investigated

System owner:

- Determine the need to bridge information capability gap
- Define information security policies



System operator:

- Relevant operational and technical experience
- Classification
- Military or civilian
- Human system interface

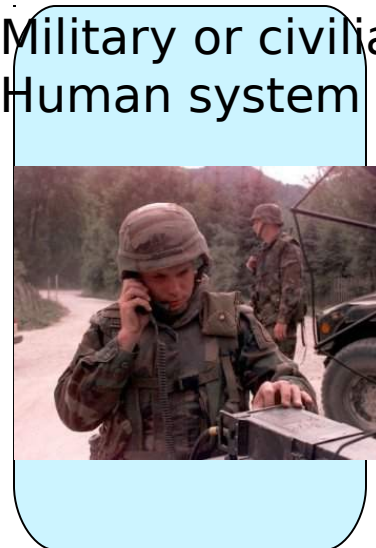



Characteristics of R2C2 (2)



g the R2C2 mission requires
perspectives and hostilities of operat
ands and limitations from each
ective were investigated
dependencies were addressed, in
2

Mission

- Perspective and hostilities of operat
- DoD, U.S. Government, or coalitio
- Mission's objectives
- System risk management
- Logistics impact due to duration of mission

Environment

Perspective



Characteristics of R2C2 (3)



the R2C2 system requirements were identified and limitations from each perspective were investigated



- Interdependencies were addressed in the context of



Mission

Environment

Perspective

Perspective

Perspective

- Location of deployment
- Variable weather conditions
- Dependable solutions to infrastructure and logistics support
- Trafficability dictates transportability and packing configuration



Characteristics of R2C2 (4)



Defining the R2C2 system requirements from four perspectives were identified. Demands and limitations from each system perspective were investigated.



- Interdependencies were addressed, in the context of R2C2



User Perspective

- Limited to COTS and GOTS technology
- Some sort of database and data management suite required
- Info management suite to facilitate operator
- Communication network
- Network topology and footprint determine type of technology and protocols
- Options drive hardware selection, power requirement, and size

Mission Perspective

Environment Perspective

Technology Perspective



Research

1. Why do we need R2C2?
2. Does a capability gap exist?

Avenues of research:

- Lessons learned from Boxing Day Tsunami and Hurricane Katrina
- Quadrennial Defense Review 2006
- Joint publications
- Interviews
- Current NPS efforts
- Deployable Joint Command and Control (DJC2) documents



Needs Analysis and Capability Gaps

- Quadrennial Defense Review 2006
 - Combating Terrorism - Joint coordination, procedures, systems, and when necessary, command and control to plan and conduct complex interagency operations.
 - Homeland Defense and Civil Support Missions - Joint communications, command and control systems that are interoperable with other agencies and state and local governments.

Capability Gaps

- Standardized C2 system that is:
 - Interoperable throughout Joint, Coalition, and interagency levels
 - Modular and scalable
 - Rapidly deployable
 - Small operational footprint



Range of Military Operations (1)

Military Operations

Goals

Categories

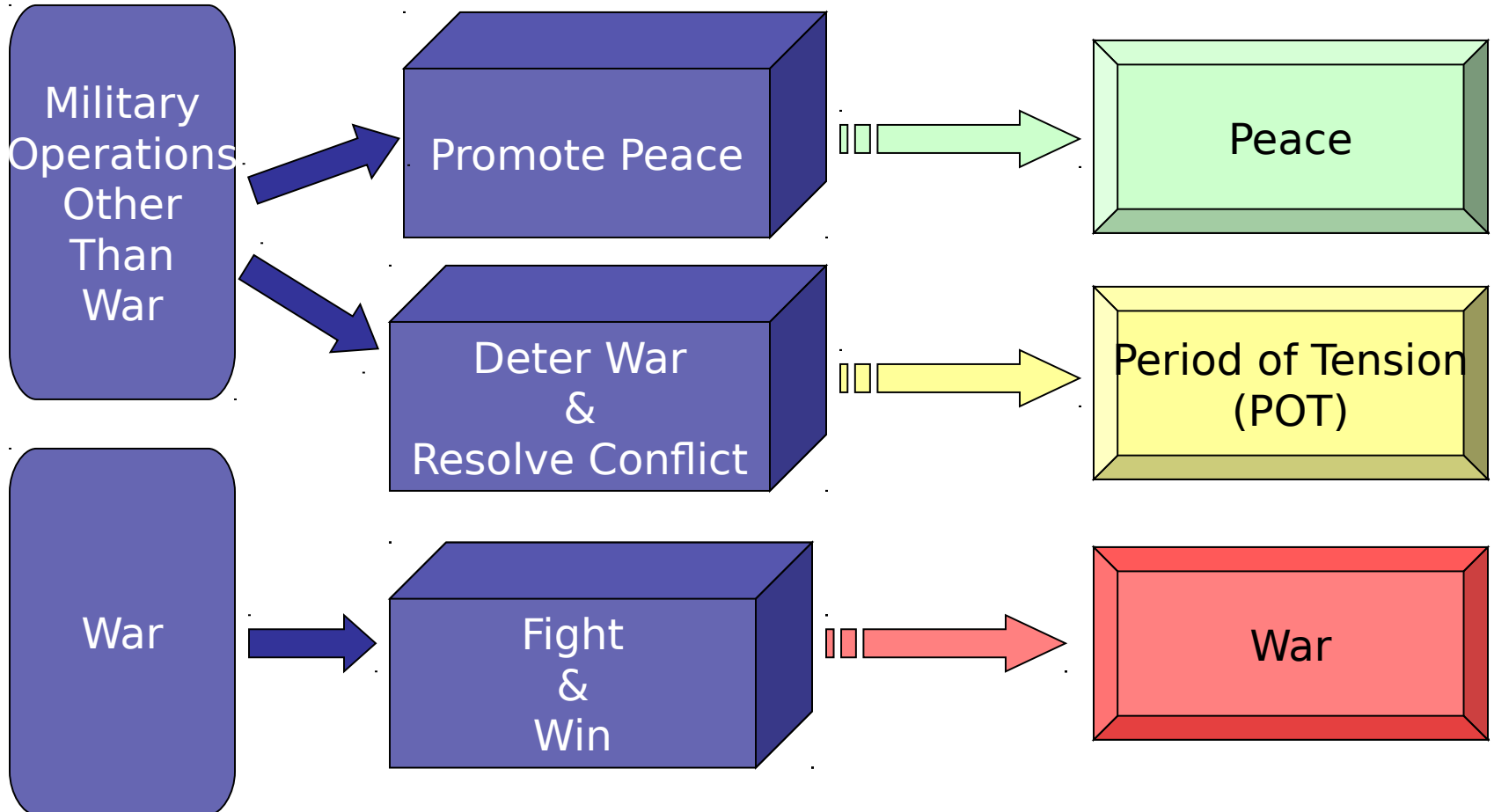



Range of Military Operations (2)

Peace

- **Pandemic - Bird Flu in Singapore**
- **Disaster Relief - Earthquake in El Salvador**

**Period of Tension
(POT)**

- **Counterterrorism - Southern Philippines**
- **Civil Unrest - Ivory Coast Noncombatant Evacuation Operation (NEO)**

War

- **Deployment - Iran conflict**



Pandemic Scenario

- Cases of transmiss
- PACOM d
- Crew esta
- Operation
- coordinat
- dissemin
- R2C2 ope
- info on A
- Collected
- Expeditio
- and supp
- stateside



Singapore
1°22'03.55" N 103°47'58.60" E



Pandemic Scenario Assumptions

- Crew is properly trained in dealing with the Avian flu
- Singapore has no objections to U.S. forces in country
- Infrastructure support of power, network connectivity, and physical security are readily available



Disaster Relief Scenario



- Magnitude 8 earthquake striking mudslides
- SOUTHCOM loses communication with the U.S. Forward Operating Base (FOB) in El Salvador, Central America
- Deploy scouts to fairgrounds to establish a CMOC, port city of Acajutla, and the U.S. Embassy
- R2C2 crew gathers SA for Regional Combatant Commander (RCC) while assisting relief efforts in country



Disaster Relief Scenario Assumptions

- Salvadoran military will provide transportation for the scouts
- Generator power for R2C2 is only available after first 24 hrs of operations
- ESG is en-route and expected to arrive in five days from the initial earthquake strike



Counterterrorism Scenario

- Intelligence reports terrorist leader in a camp near city of Buriasan
- U.S. and Filipino Special Forces with an R2C2 system leave exercise in Basilan to find High Value Target (HVT)
- Forces gather Human Intelligence (HUMINT) in city of Buriasan to locate camp



Buriasan, Philippines
7°54'00.00" N 123°45'00.02" E

- Forces surround camp to gain positive identification (ID) of HVT
- Video and imagery are passed through R2C2 back to PACOM for confirmation
- Forces await confirmation ID and follow on orders to strike



Counterterrorism Scenario Assumptions

- Intelligence received is credible
- The Philippine government supports the coalition team and their efforts
- Buriasan's local population is aware of terrorist activities and are cooperative in supplying information regarding the terrorist camp location
- U.S. and Filipino forces have been conducting exercises utilizing the capabilities of the R2C2



Civil Unrest Scenario

- UN/French forces
- EUCOM deploys
- U.S. Embassy
 - Yamoussoukro
 - Abidjan
- Yamoussoukro c
 - Aide UN/Fre
 - Monitor rebel
- Abidjan crew:
 - Coordinate e
 - embassy with ESG
 - Maintain communication with Re



Ivory Coast, Africa
7°31'32.45" N 5°35'00.42" W



Civil Unrest Scenario Assumptions

- ESG is en-route to provide a Marine Expeditionary Unit (MEU) to conduct NEO
- R2C2 crews are able to communicate with ESG
- ESG will be prepared to provide information to support the R2C2 crews
- Adequate to limited infrastructure is available for R2C2 to operate in Yamoussoukro
- Sufficient infrastructure is available to support R2C2 at the U.S. Embassy



Deployment Scenario

- U.S. – Iranian conflict has begun and U.S. forces have entered the country
- CENTOM deploys R2C2 crew to Shirāz to:
 - Determine a DJC2 staging area
 - Support C2 of ground troops
- Scouts deployed throughout the city to find staging area and conduct battle damage assessment for RCC and ground forces



Shirāz, Iran

37°25'49.00" N 45°55'30.99" E

- R2C2 crew conducts coordination with construction battalion for DJC2 staging



Deployment Scenario Assumptions

- Ground forces will experience light resistance from Iranian forces in the cities of Būshehr and Shirāz
- Insurgent threats in the city are not expected
- Once integrated with the ground forces, the R2C2 will provide a dedicated power source
- Chemical, Biological, Radiological (CBR) warfare is a viable threat



Scenario Stress Matrix (1)

- 3 areas of concern that would affect the design of the R2C2 system
- Matrix analyzes R2C2 system, while deployed, based upon a series of stress points

Mission	User	In Situ
<ul style="list-style-type: none">• Response time• Probability of occurrence• Impact• Prior intelligence/information	<ul style="list-style-type: none">• User expectation• Stakeholders• Complexity of operation• Duration (stay + op time)	<ul style="list-style-type: none">• Environment• Infrastructure• Trafficability• Special requirements



Scenario Stress Matrix (2)

		General Goals	Scenarios	Examples	Respond Time	User expectation		
							input (details / freq)	process
MOOTW	War	Fight & Win	Combat Ops (Attack)	Deployment	1. Adequate (> 1 day) 2. Average (< 1 day) 3. Short (< 12hrs) 3. short, due to plans to attack U. S. interst, intel is needed for counter-offensive attacks	high / high	high/moderate	very high/high
			Combat Ops (Defend)					
			Combat Ops (Blockade)					
	POT	Deter War & Resolve Conflicts	Peace enforcement	Civil Unrest (eg. Ivory Coast)	3. Time is critical. Tensions are increasing and intel is needed to determine scope of operations	High/Very High	High/Moderate	High/Moderate
			Noncombatant Evacuation Operations (NEO)					
			Strikes / Raids	Counter-terrorism (eg. terrorism off southern philippines)	1. adequate, caution must be taken to prevent detection	high / high	moderate/moderate	high/moderate
			Show of forces					
			Counterterrorism					
	Peace Keeping	Disaster relief (eg. El Salvador)	3. time is critical, need to be inserted quickly for intel gathering	high / high	low	high / moderate		
	Counterinsurgency							
Peace	Promote peace, support law & order	Anti-terrorism	Pandemic (eg. Bird Flu)	1. Adequate. Should have ample time to access conditions (situations	moderate / high	low	low / moderate	
		Disaster relief						
		Peace building						
		Counter drug						
		Domestic support						
		Pandemic control						

Low stress
 Moderate stress
 High stress



Feedback from Stakeholders

- Received DJC2 JP, N71, and J88 approval of missions and project direction
- CENTCOM, EUCOM, and N71 representatives have stated “the scenarios are viable” for potential R2C2 missions
- “The Contingency Response Group [CRG] could/would deploy for all 5 missions you list. We are manned and equipped to be light and lean, so any effort to reduce manpower or equipment airlift requirements without reducing capability are always being explored.”
 - LT Col Jeffrey Renner, 86th Air Mobility Squadron, 27 April 2006



Mission Analysis Conclusions

- Identified four perspectives that dictated R2C2 design
 - User, mission, environment, and technology
- Need for R2C2 system was recognized
- R2C2 system compliments Joint Pubs and doctrines for current and future military operations
- Challenged by multiple users, 5 scenarios were developed to meet the user's needs
- Users confirmed the potential R2C2 scenarios



Requirements

LT Lennard Cannon

Maj. Yu Loon Ng

Capt. James Neo



Requirements Outline

- Capability Production Document (CPD) requirements
- Broad Area Announce (BAA) requirements
- Purpose of functional flow
 - Functional flow
 - Functional tree
- R2C2 operational requirements
- Timelines
- R2C2 system requirements



CPD Requirements

- CPD 1. Agile, quick response capability with small footprint
- CPD 2. Satellite connectivity designed to serve up to four operators
- CPD 3. Expandable to up to ten in group collaboration with reachback to internet, NIPRNET, SIPRNET, and required multinational/coalition networks and collaboration tools and services
- CPD 4. Transportable on commercial or military aircraft
- CPD 5. Transportable by 2 persons
- CPD 6. Operable on standard electrical power sources
- CPD 7. Capable of operating on small lightweight organic power sources such as host national power grid, facility power or generators
- CPD 8. Operable in austere locations
- CPD 9. Provide data and voice communications and collaborative capabilities via reachback
- CPD 10. Provide two simultaneous networks
- CPD 11. Provide local physical storage
- CPD 12. Provide limited capability to include SHF, SATCOM, UHF, TACSAT, INMARSAT, and handheld global satellite phone for SA, planning and other C2 functions



BAA Requirements

- BAA 1. Provide capability to connect to two (2) GIG-accessible, crypto-covered networks at once (e.g., NIPRNet, SIPRNet, CENTRIXS)
- BAA 2. Provide secure wireless (objective) to clients
- BAA 3. Utilize Everything over Internet Protocol (EoIP)
- BAA 4. All equipment must meet commercial standards for carry-on luggage for commercial aircraft (Objective: Transport by two persons)
- BAA 5. Provide Net Centric operations to the maximum extent possible
- BAA 6. Demonstrate multi-mode (data, video, and voice) operations
- BAA 7. Provide minimum of four (4) Voice Over IP (VoIP) telephonic instruments and four (4) client computers.
- BAA 8. Must be able to use thin or thick clients, and must support 5 clients (threshold)/15 clients (objective)
- BAA 9. Provide radio with 1.024 Mbps threshold, 4.196 Mbps objective per network
- BAA 10. Provide reliability, maintainability, availability, built-in test and logistic support as an objective
- BAA 11. Provide compact, ruggedized, protective packaging



Purpose of the Functional Analysis

- Determine system requirements
- Determine what the system does
- Determine how system will be used
- Determine range of system operations
- Determine logistical support aspects



Functional Flow with Universal Joint Task List

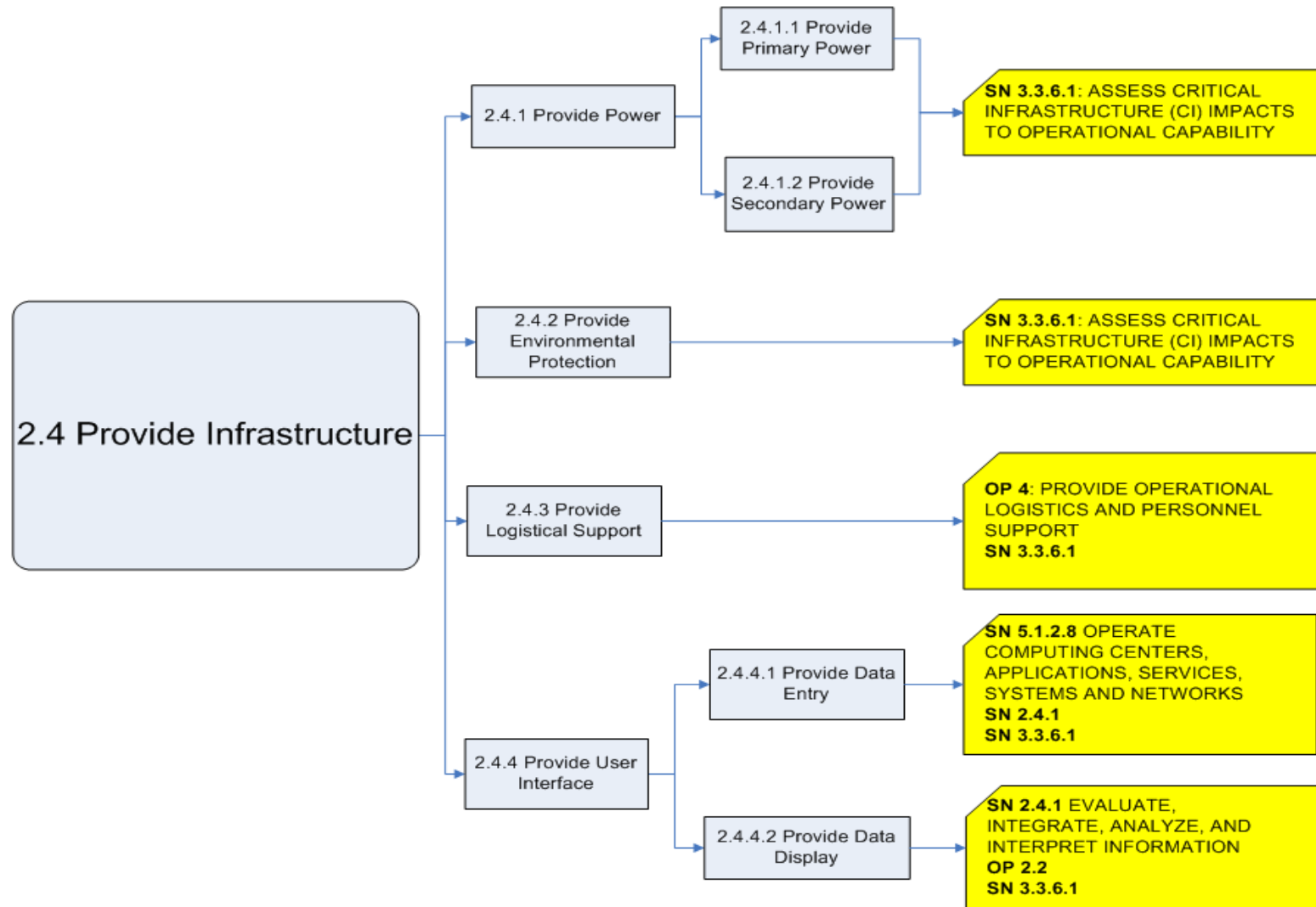



Functional Tree Diagram

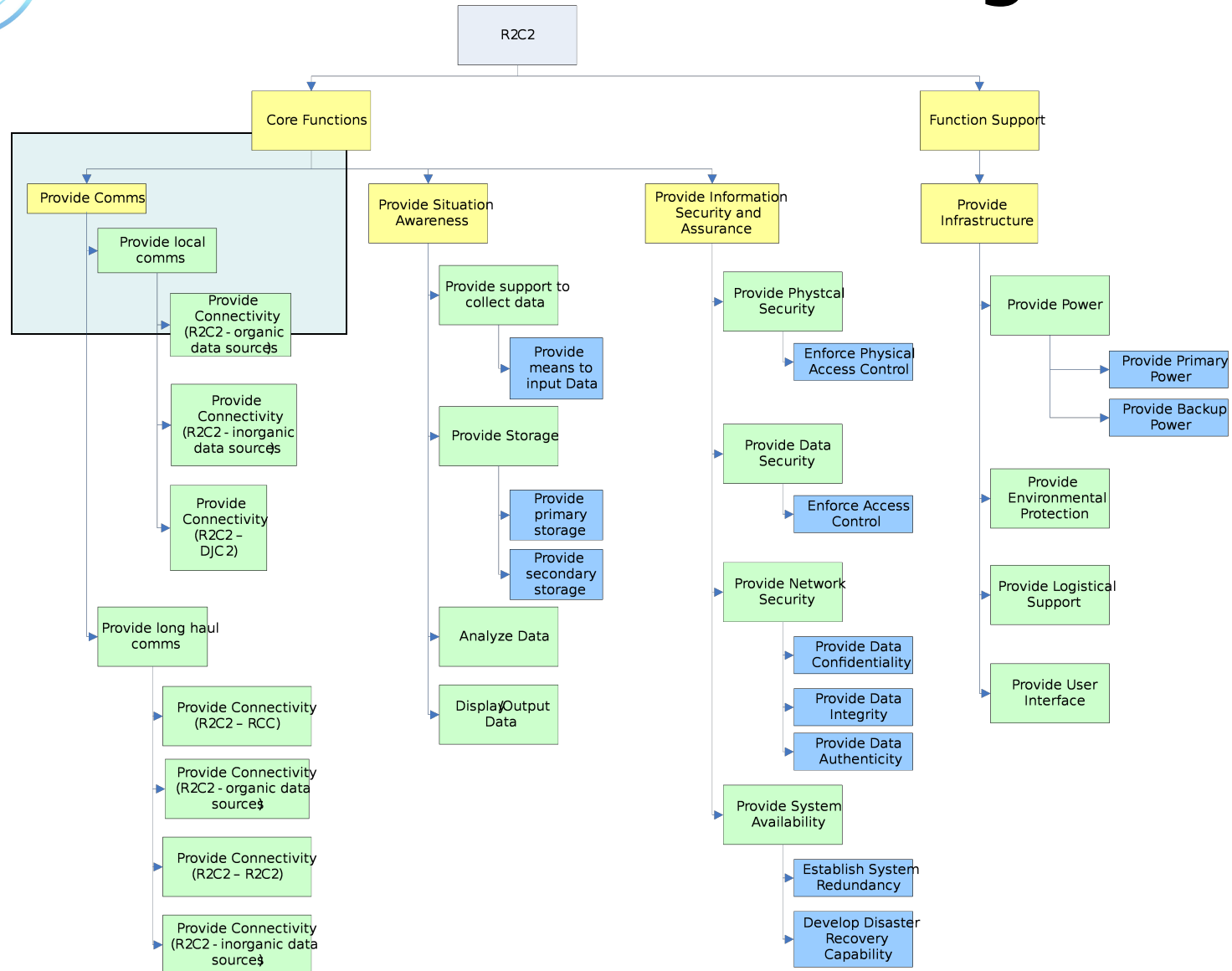



Functional Tree Diagram

Provide Communications

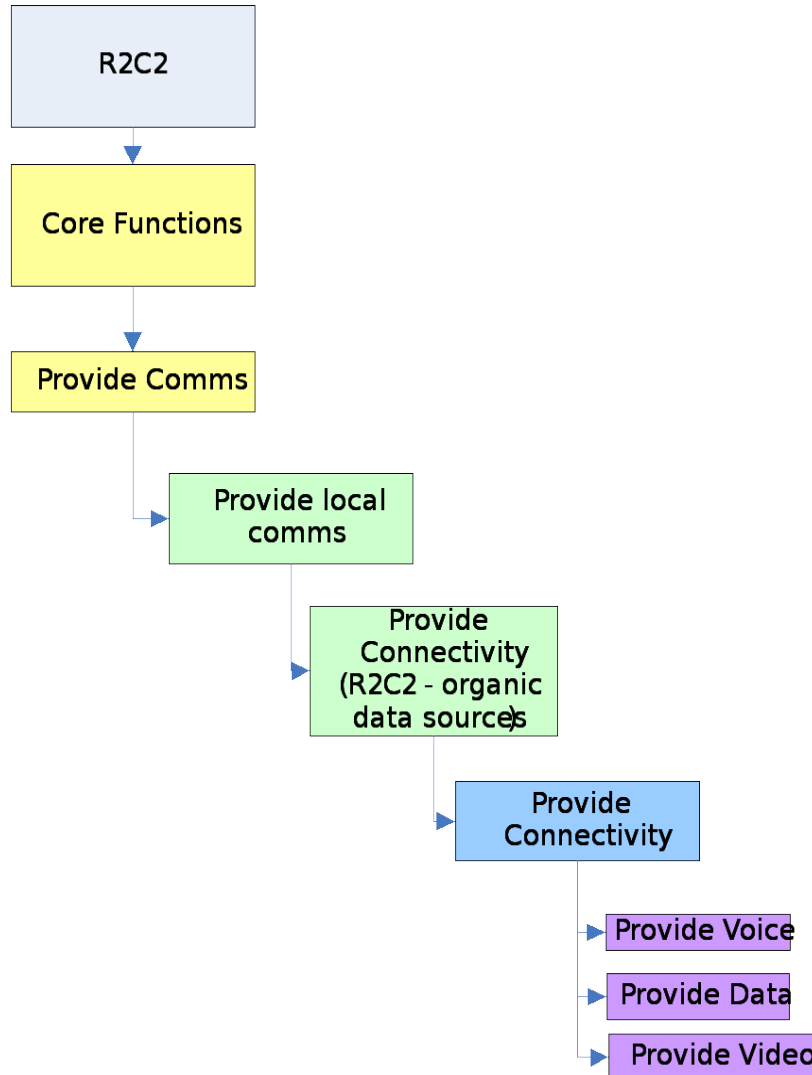



Operational Requirements

- OR 1. Provide capability of local and long haul communications to the RCC, DJC2, other R2C2 systems, coalition partners, military assets, and civilian assets
- OR 2. Provide secure means, physical security, data security, and network security, of passing tactical information to the supported Commander for situation assessment
- OR 3. Provide means of collecting data from organic or inorganic assets
- OR 4. Provide self supporting power supply in addition to capability of accessing inorganic power supply for sustained operations
- OR 5. Provide capability for operators to receive, display, analyze, filter, and pass simultaneous data from organic or inorganic assets
- OR 6. Provide compact, rugged, and mobile packaging
- OR 7. Provide flexibility for mission dependent software and hardware configurations



Disaster Relief Timeline (1)

- 0+00 SOUTHCOM receives reports of major earthquake in Central America
- 0+10 SOUTHCOM unable to contact Forward Operating Base and Embassy
- 0+50 SOUTHCOM alerts R2C2 crew
- 1+00 SOUTHCOM configures R2C2 system to include long haul communications, local communications, information management system, video or digital camera, maps, firearms, and translation software
- 6+00 R2C2 crew departs
- 12+00 R2C2 crew arrives via helicopter to airport
- 12+20 R2C2 crew finds U.S. personnel and begins to set up R2C2
- 13+00 R2C2 crew conducts voice and data checks with SOUTHCOM and with organic communications and sensors
- 13+30 R2C2 crew sends video clips of the coastline and airfield taken while onboard helicopter to SOUTHCOM
- 15+00 R2C2 reports that U.S. military personnel accounted for at airport with minor first aid needs
- 20+00 R2C2 scouts find rides with local military to Embassy, fairgrounds, and Acajutla Port
- 22+00 Scouts give on-station report to R2C2



Disaster Relief Timeline (2)

+1 day Scouts give hourly reports

From the port, the scout reports damage and security issues, such as, is it suitable to receive shipments from ESG and other relief ships, are roads from port to San Salvador open, is it safe to operate?

From the Embassy, the scout reports status of U.S. personnel and medical requirements

From the fairgrounds, the scout reports status of creating a Civil Military Operating Center (CMOC) with Local Government, International Organizations, and NGOs

R2C2 relays port and landing zone data to ESG (pictures/voice) and RCC

R2C2 receives satellite imagery from RCC and shares information with the CMOC

FOB provide mobile generators for power

+ 5 day ESG arrives

Scouts pass bi-hourly reports to R2C2

R2C2 compiles reports and passes status to SOUTHCOM and ESG

R2C2 crew relays evacuation data between CMOC and ESG

R2C2 relays CMOC needs for medical, water, and equipment to SOUTHCOM and ESG

R2C2 operations continue until some local communications have been restored



System Requirements (1)

	Pandemic	Disaster Relief	Counter Terrorism	Civil Unrest	Deployment
Bandwidth (local)	Red	Red	Red	Yellow	Yellow
Bandwidth (long haul)	Red	Red	Red	Yellow	Yellow
Security	Yellow	Yellow	Red	Red	Red
Data Types	Yellow	Yellow	Red	Yellow	Yellow
Power (Required)	Red	Red	Yellow	Red	Yellow
Power (Duration)	Yellow	Red	Green	Yellow	Yellow
Information Management	Red	Red	Green	Yellow	Yellow
Weight	Red	Yellow	Green	Yellow	Yellow

Legend	Bandwidth	Security	Data Types	Power (Required)	Power (Duration)	Information Management	Weight
Red	>2 Mbps	Physical, Data & Network	Streaming Video	High	> 24 Hrs	High	>90
Yellow	1-2 Mbps	Data & Network	Video & Images	Medium	12-24 Hrs	Medium	70-90
Green	<1 Mbps	Data	Voice	Low	<12 Hrs	Low	<70



Requirements Mapping

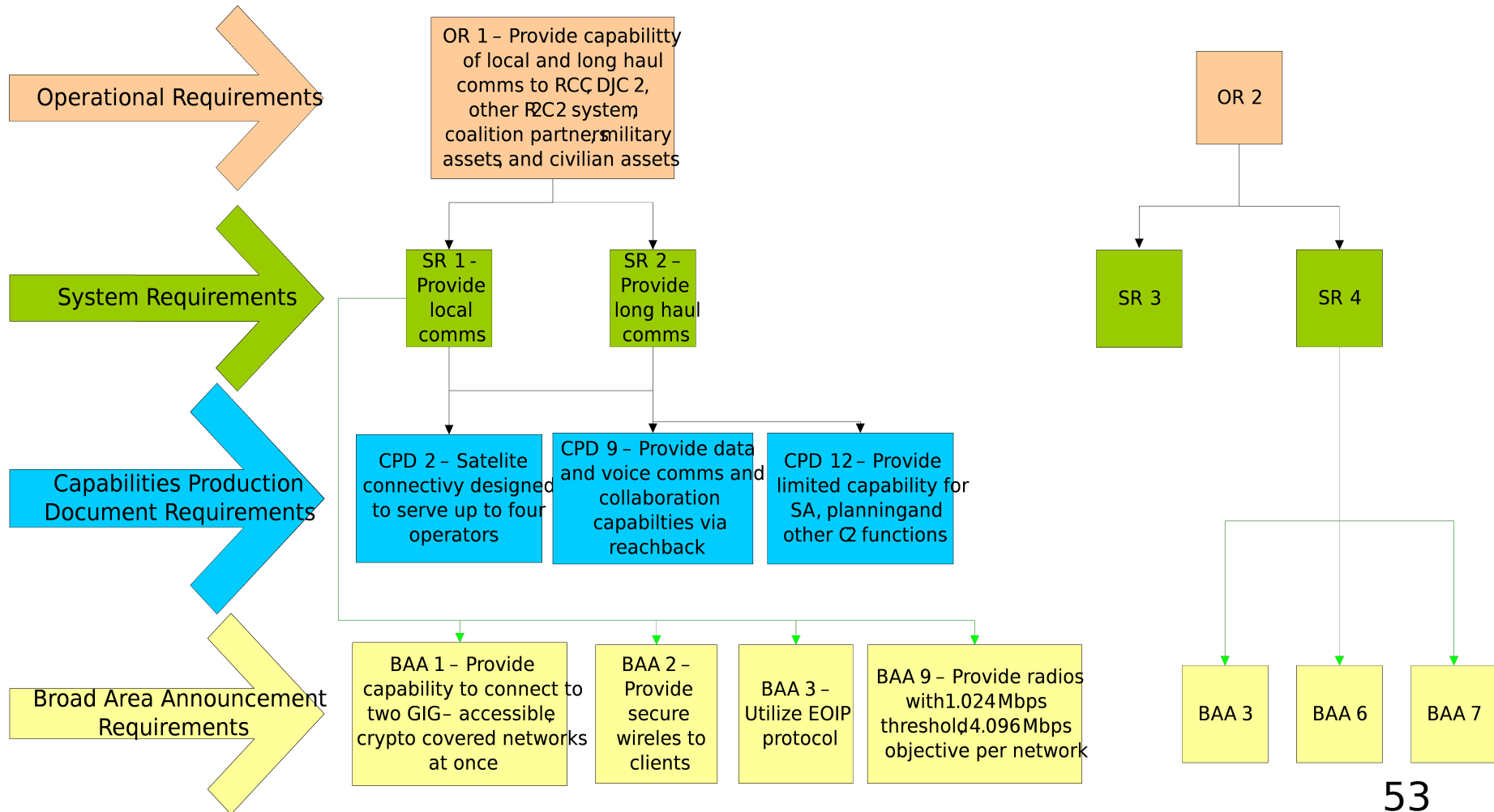



Requirements Conclusion

- Top-Down Systems Engineering approach used to develop requirements
- Mission oriented requirements
- Requirements tied to strategic guidance (UJTLS)
- Functional Analysis uncovered additional requirements (power, scouts, data, and security)



R2C2 System Architecture

ENS Jim Colgary

Ms. Chin Chin Ng

Mr. Guan Chye Tan



Architecture Outline

- Communication links
- Architecture Baseline
- Market survey
- Primary, Local, and Civil/Military Suites
- Information Management (IM) tools
- Power



Identification of Communication Links

Civilian Communication -

Via Voice. Enhancement would include providing local HA/DR workers Internet connectivity for data transfer and collaboration



**Coalition Communication -
Via voice and CENTRIXS.**

Strategic Communication-

Via voice, video, and data transmission through a long haul connection. Enhancement would include using high bandwidth

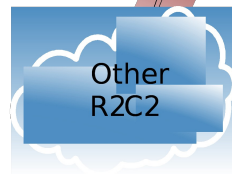

Tactical Communication -

Via voice. Enhancement would include using a wireless, long range, high bandwidth connection for data and video.



R2C2 Architecture Baseline

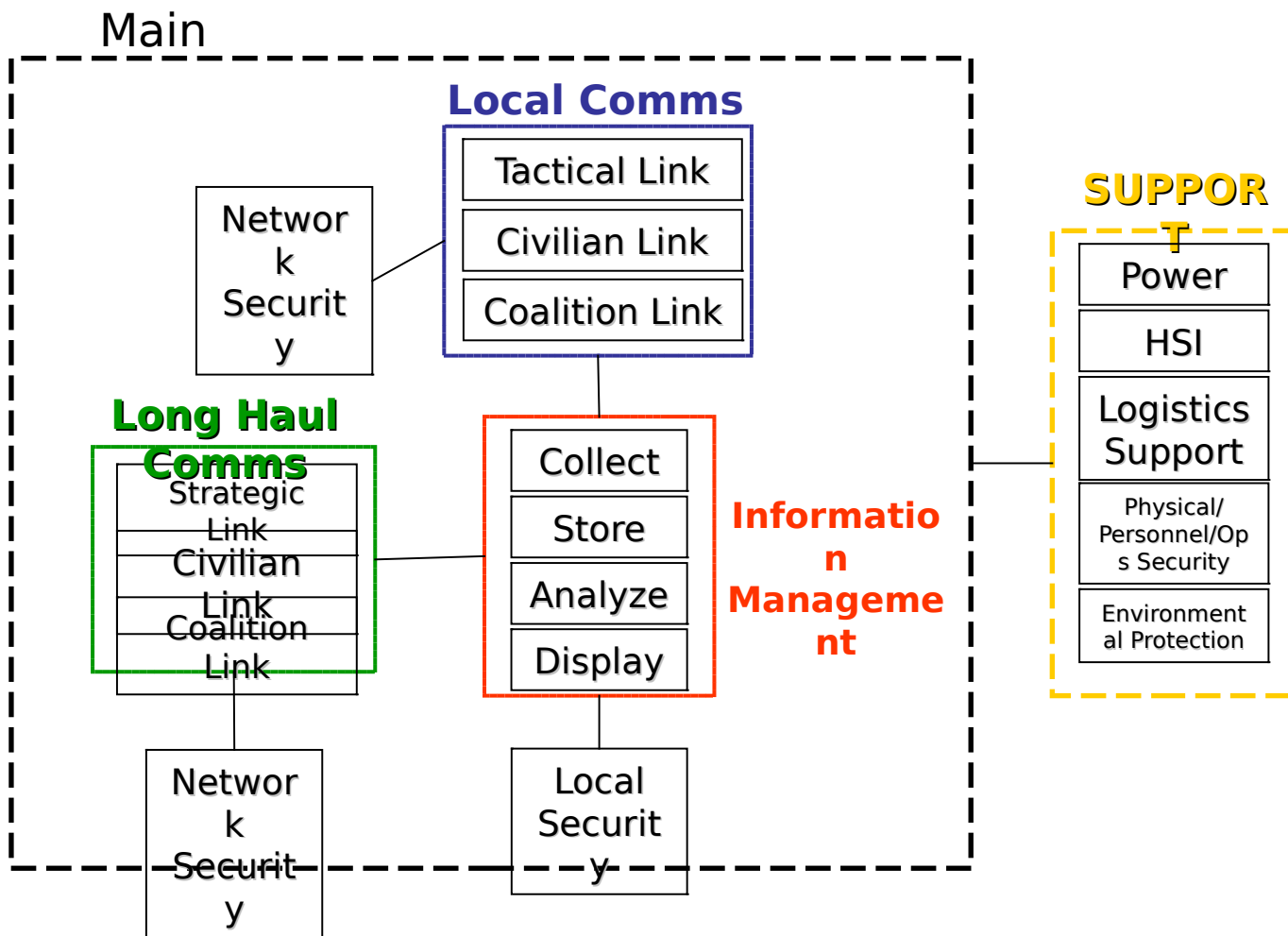



Market Survey

- The R2C2 team was divided into smaller groups to research areas of communications, Information Management, power, and sensors
- Conducted to fully identify all methods and equipment necessary to fulfill the five functional areas
- All researched equipment and software were geared towards creating a small, portable unit for use in an austere location
- All results acted as alternatives for each area of research



Communication Alternatives

Local Voice COM
Satellite Phones
<i>GlobalStar</i>
<i>Iridium</i>
Radio Phones
Cell Phones
Personal Cell System
Military Radio
<i>Manpack Radio</i>
<i>Land Mobile Radio (LMR)</i>

Local Data COM
Wireless Personal Area Network (PAN)
WiFi: 802.11b
WiMax: 802.16

Long Haul SATCOM Terminals
Norsat Globetrekker
Norsat U.P. 5200
Swe-dish IPT-i Mil Suitcase
TCS DVM-90
GSI GlobeComm Auto-Explorer (.77m)

Alternatives were identified and evaluated against each other to determine the best option in each category.



IM, Power, and Sensor Alternatives

Information Management
Geospatial Information Application
<i>Google Earth</i>
<i>Arc View</i>
<i>Microsoft Terraserver</i>
<i>FalconView</i>
<i>GCCS-J</i>
Collaborative Information Environments
<i>DCTS</i>
<i>IWS</i>
<i>Groove</i>
Digital Storage
<i>Magnetic</i>
<i>Optical</i>

Power System
Generator (portable)
External Battery
<i>BA5590 Military</i>
<i>N-Charge</i>
Micro Fuel Cell
Solar
Wind

Sensors
Satellite Imagery
<i>Synthetic Aperture Radar (SAR)</i>
<i>Infrared</i>
<i>Electro Optics</i>
Aerial Imagery
<i>Unmanned Aerial Vehicle</i>
<i>On-board systems for UAV</i>
Seismograph
Meteorological sensors
Biometric Sensors
Virus Test Kit
Biological Sensors
Fix Position Systems



R2C2 Architecture Baseline

Highlighted Suites

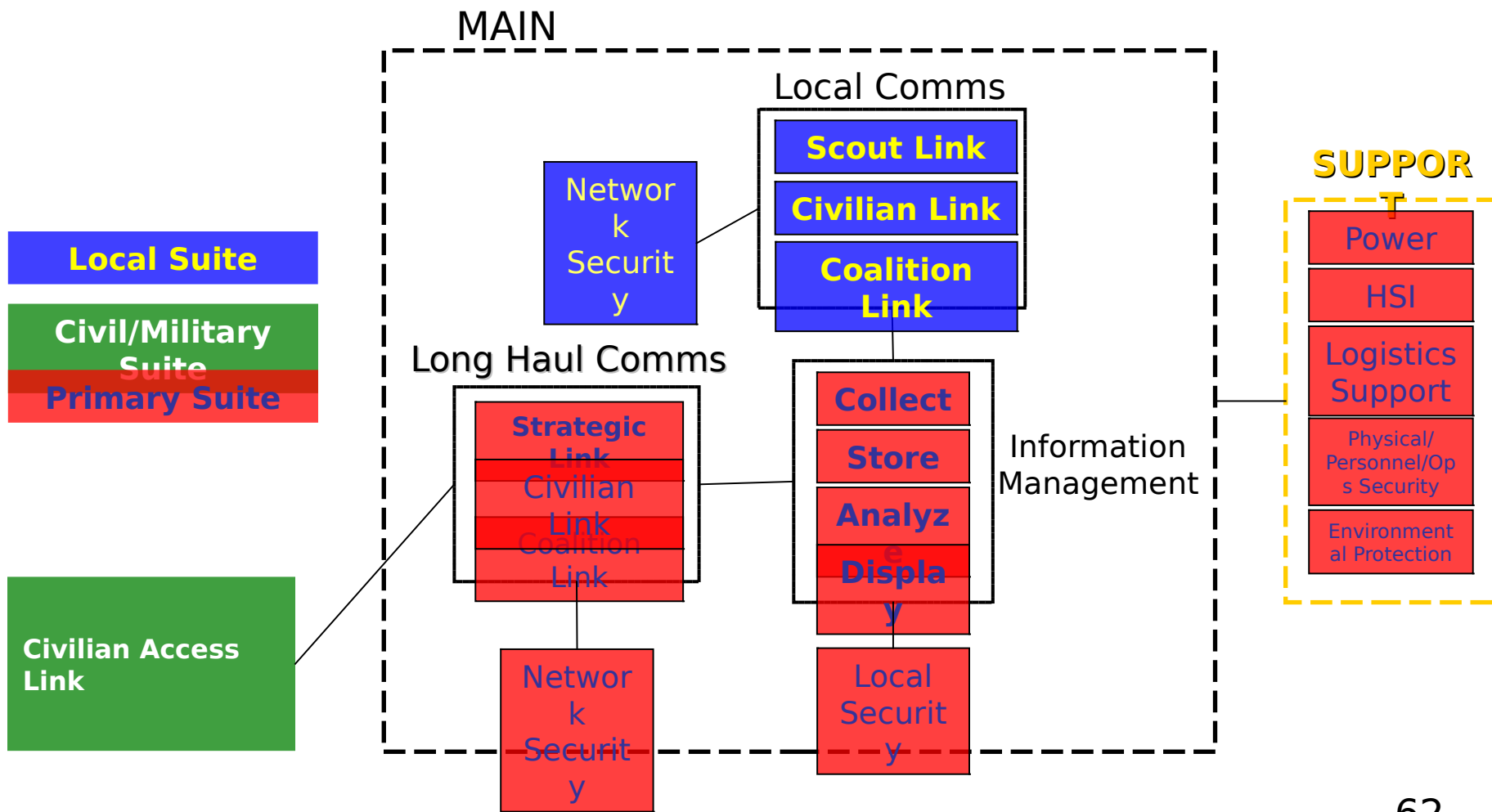



Suites Design Alternatives

- Reduced to 8 potential combinations through trade offs

Primary Suite	Local Suite	Civil/Military Suite
<i>Alternatives</i>	<i>Alternatives</i>	<i>Alternatives</i>
•VSAT Terminal 1	Voice <ul style="list-style-type: none">•Satellite Phones or Military Radios (manpack/handheld LMRs)	•Integrated
•VSAT Terminal 2	Voice and Data <ul style="list-style-type: none">•WiMax/WiFi coupled with SAT Phones or radios	•Separate Unit



Primary Suite

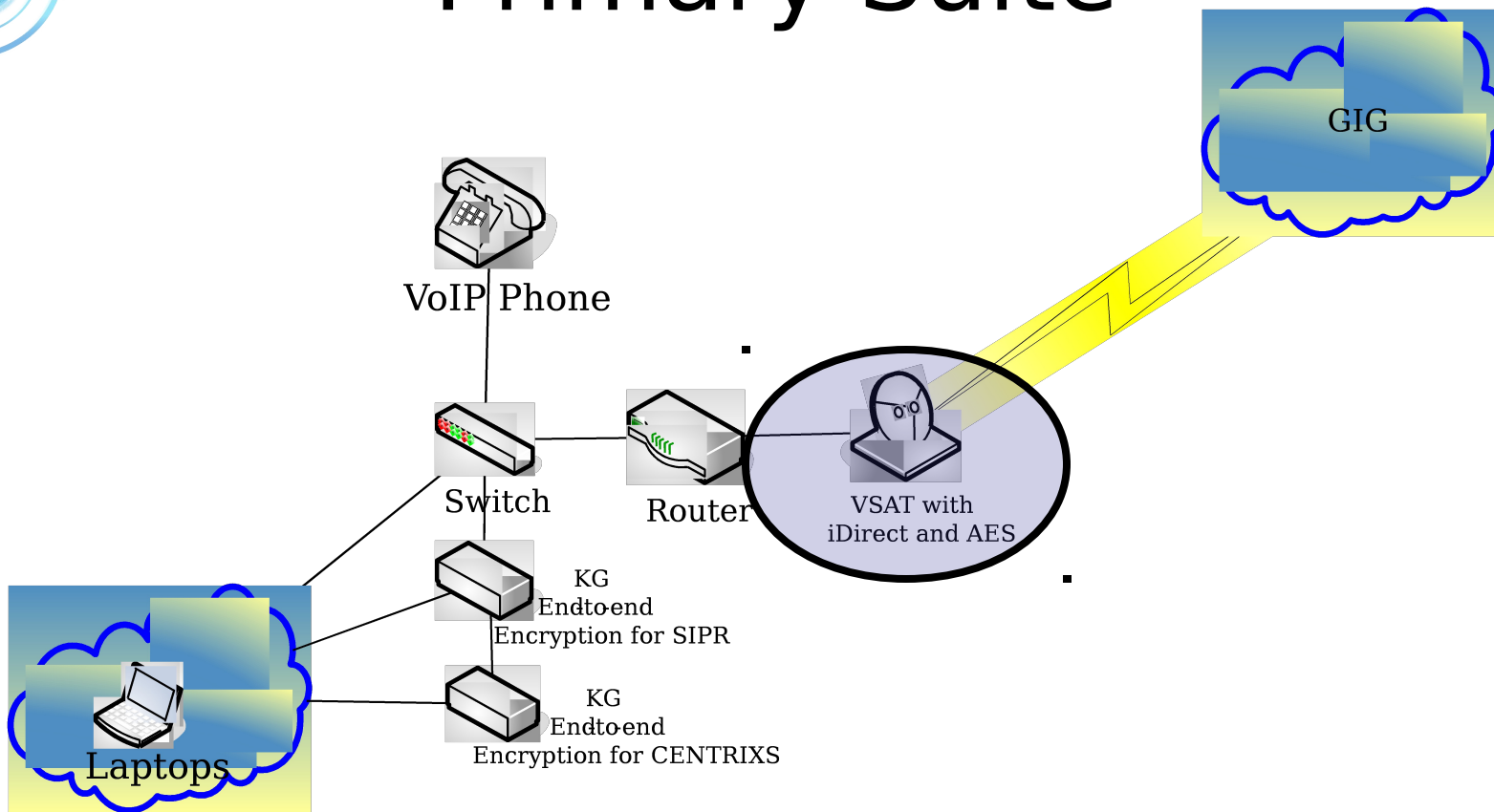

R2C2 CLASS and
UNCLASS Processing Base
For SIPR CENTRIXS and
NIPR

The satellite terminal has the most impact on the system performance and was the key component evaluated



Local Suite - Voice Alternatives

- Satellite Phones or Military Radios

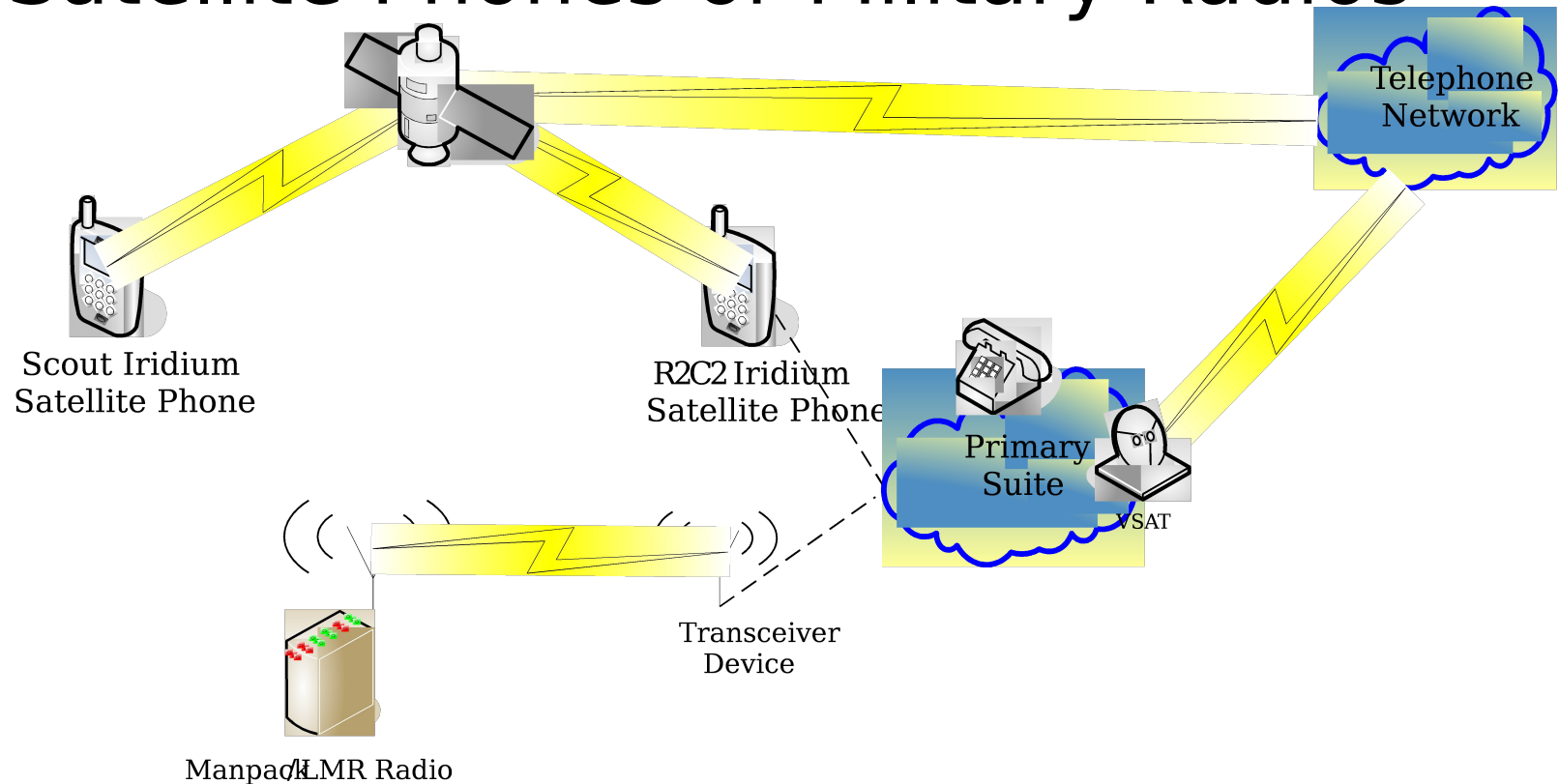

SAT Phones offer voice transmission to another SAT Phone or to the R2C2 VoIP phone. Military radios transmit radio to radio



Local Suite - Voice/Data Alternative C

- WiMax/WiFi
 - With Radios/SAT phones

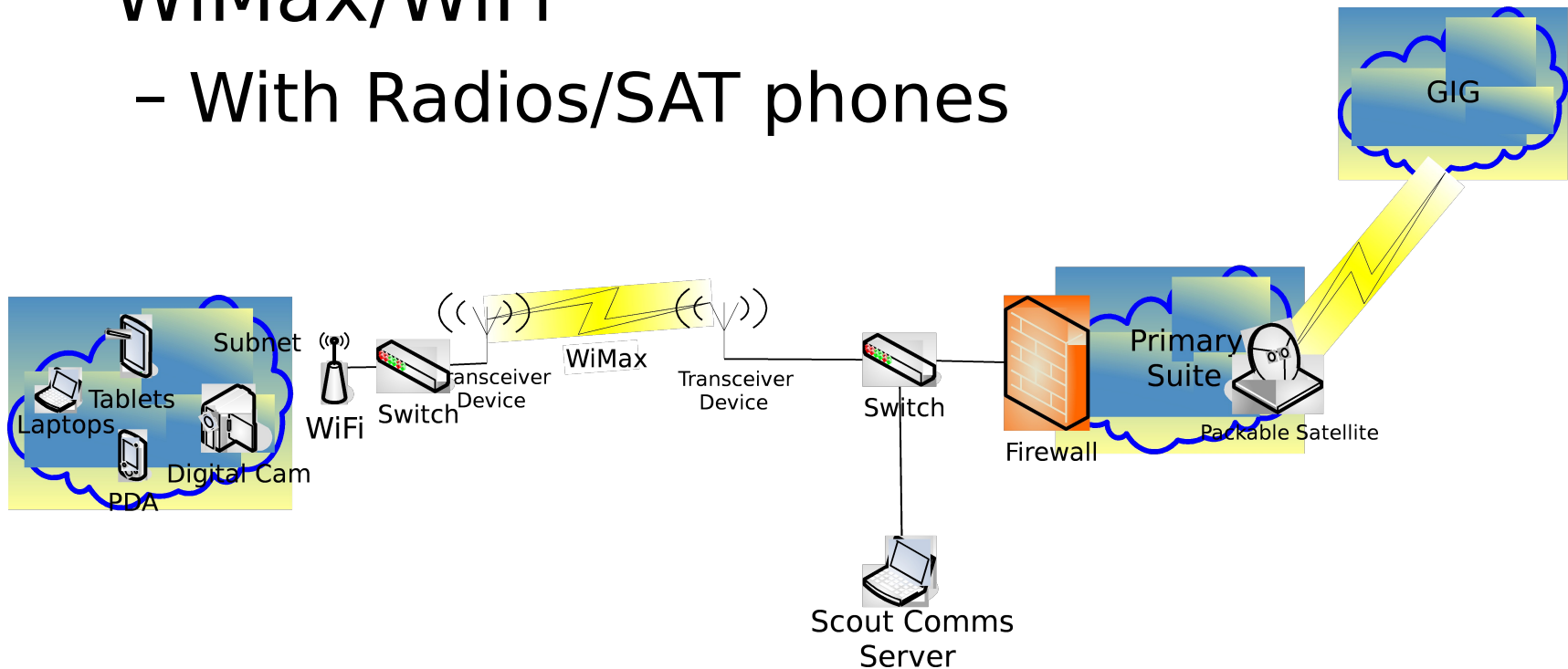

Data Link allows for video, pictures, and data to be transmitted over a long distance. The scout server and firewall protect the R2C2's security and bandwidth



Civil/Military Suite - Alternative A

- Integrated Civil/Military Suite

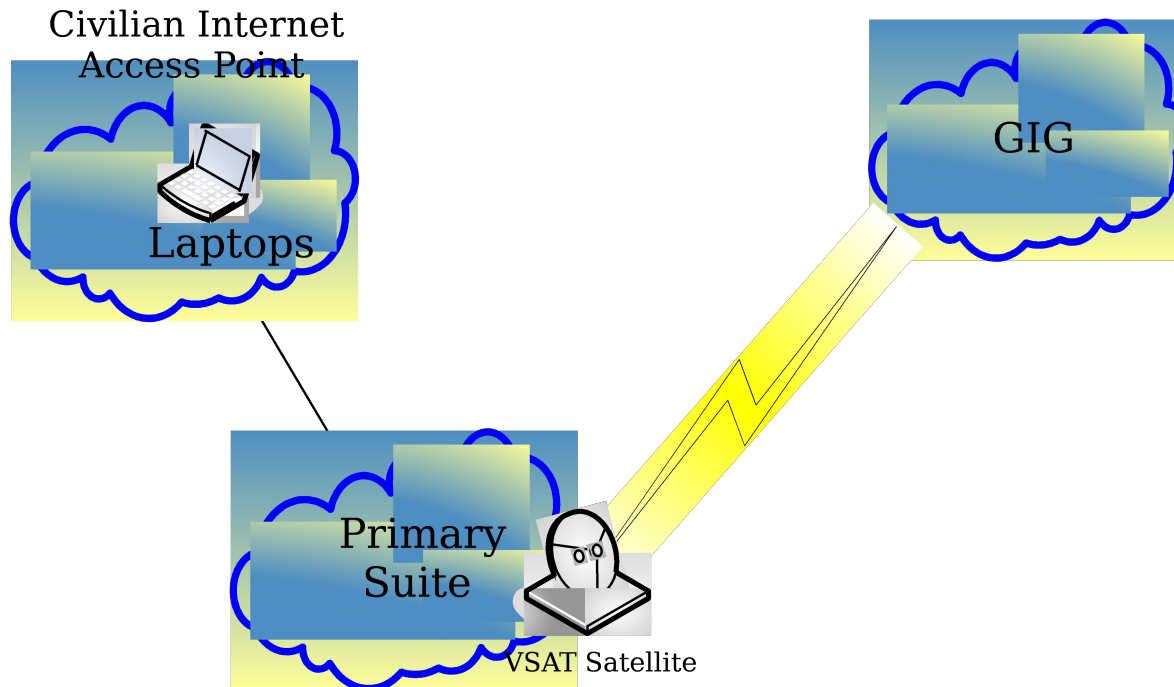

Integrated CMS plugs into the existing PS router allowing civilian use of VSAT to access the internet



Civil/Military Suite - Alternative B

- Separate CMS

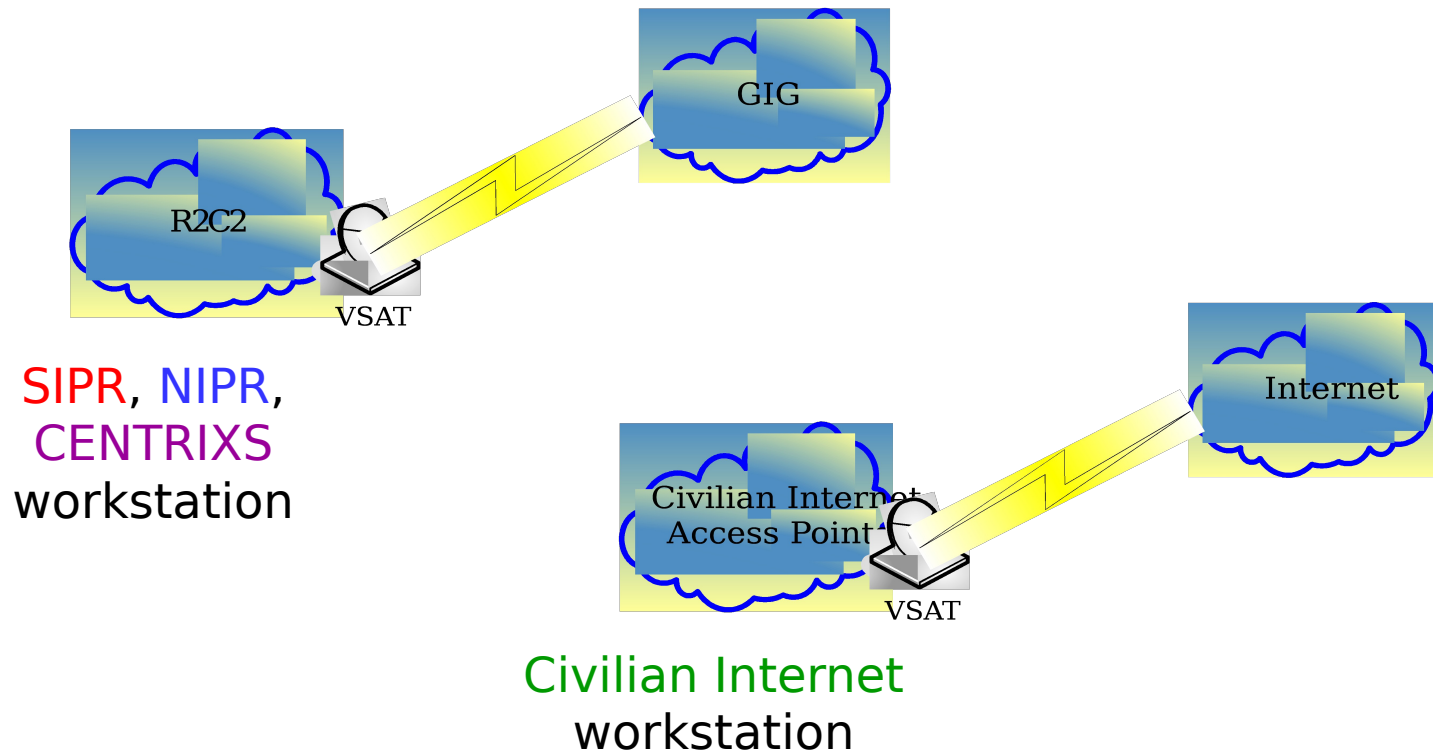

Separate CMS utilizes an entirely separate VSAT and package of network gear, segregating military and civilian work



Information Management Tools

- We have identified that the R2C2 system must incorporate
 - Collaborative Information Environment (CIE)
 - Defense Collaborative Tool Suite (DCTS)
 - Geospatial Information tools
 - FalconView (GIS software for COP and 3D terrain visualization)
 - Non-volatile Digital storage
- Analysis of the DJC2 software suite to be loaded on Core System laptops contains the necessary applications for R2C2 IM
 - Enhances commonality, ease of production, and interoperability



Power

- System usage power requirements were matched up with power equipment from the market survey
- Trade offs were done to conclude that:
 - Very small, gas generators do exist on the market and are capable of providing the necessary power
 - Batteries containing enough power to sustain the system for the required duration do not exist
 - Solar and fuel cell technology is not mature enough to seriously consider



Architecture Conclusions

- Overall system design is segmented into three suites
 - PS, LS, and CMS
- PS has two VSAT alternatives
- LS has two voice alternatives and one data/voice alternative
 - SAT phones and Military Radio
 - WiMax/WiFi link
- CMS has two alternatives
 - Integrated or separate
- R2C2 will use DJC2 IM package
- R2C2 must have generator or battery organic power



Information Assurance

Maj. Eric Wong

Maj. Harry Lim

Maj. Yu Loon Ng

Ms. Chin Chin Ng

Mr. Guan Chye Tan



Information Assurance Outline

- Security engineering process
- Discover information protection needs
- Define system security requirements
- Design system security architecture
 - Architectural approach
 - Defend the network and infrastructure
 - Protect the boundary
 - Secure the computing environment
- MLS technology research
- Conclusion



Security Engineering Process

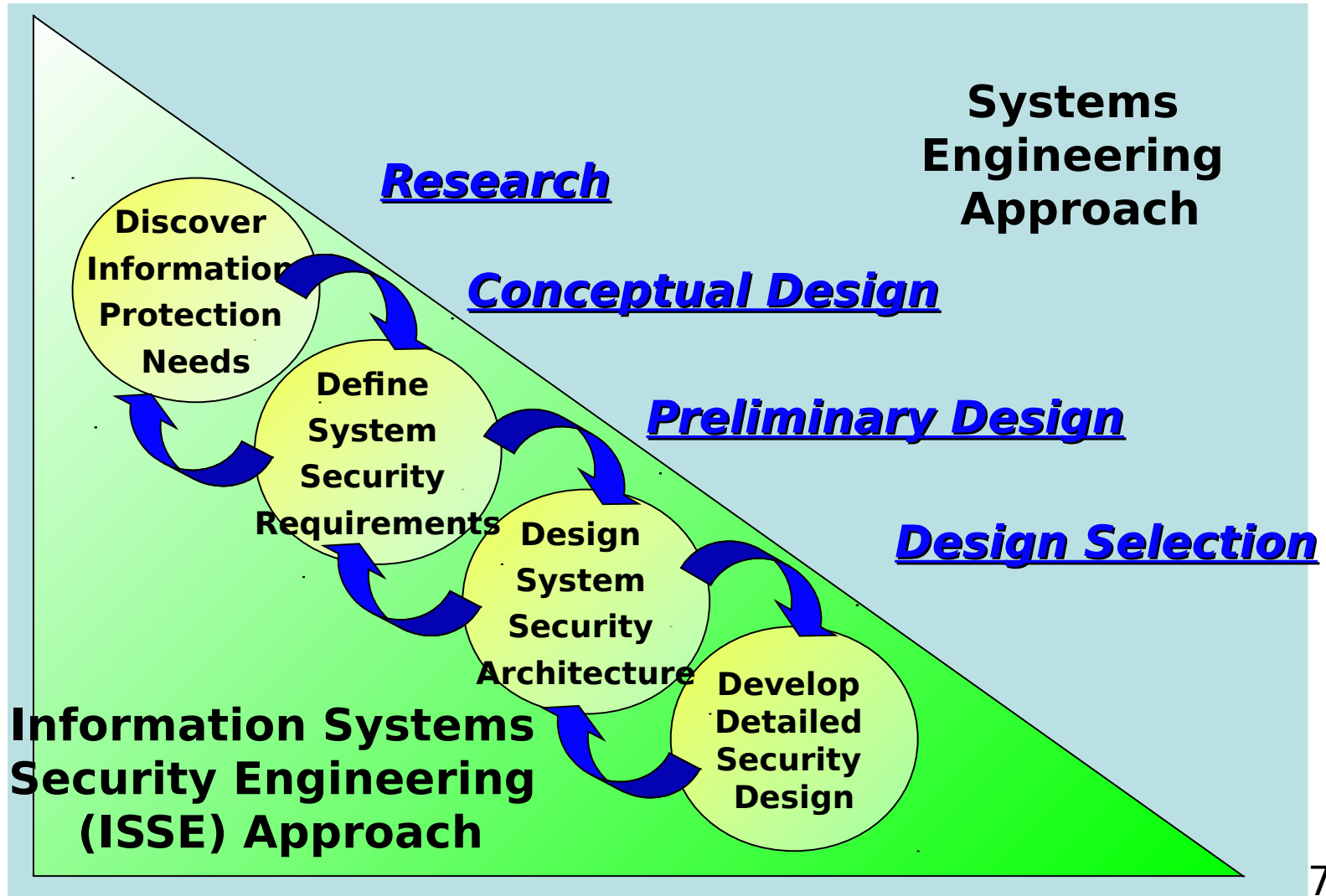



Discover Information Protection Needs

- Mission analysis
- Cyber threats
 - **Passive attack**
 - **Active attack**
 - **Close-in attack**
 - Insider
 - Distribution



Define System Security Requirements

- Broad Goals
 - Confidentiality
 - Integrity
 - Availability
 - Identification & Authentication
- Connectivity
 - SIPRNET
 - NIPRNET
 - Coalition & Civil/Military



Design System Security Architecture

- Defining the context
 - Enclaves
 - Primary Suite
 - Local Suite
 - Civil/Military Suite
 - Boundaries
 - Primary - Local
 - Primary - RCC
 - Primary - CMS

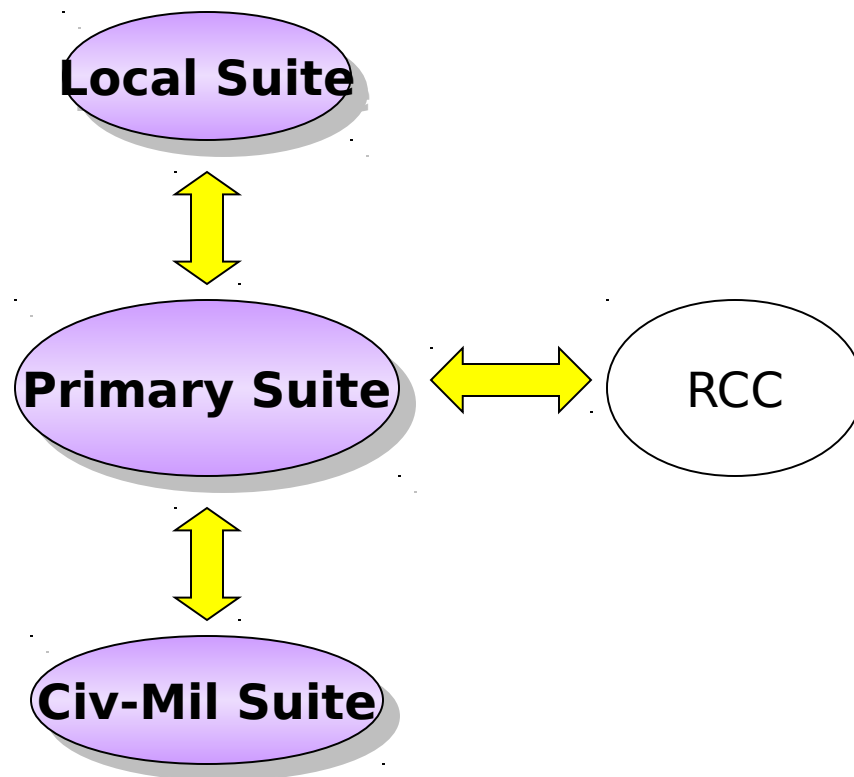



Architectural Approach

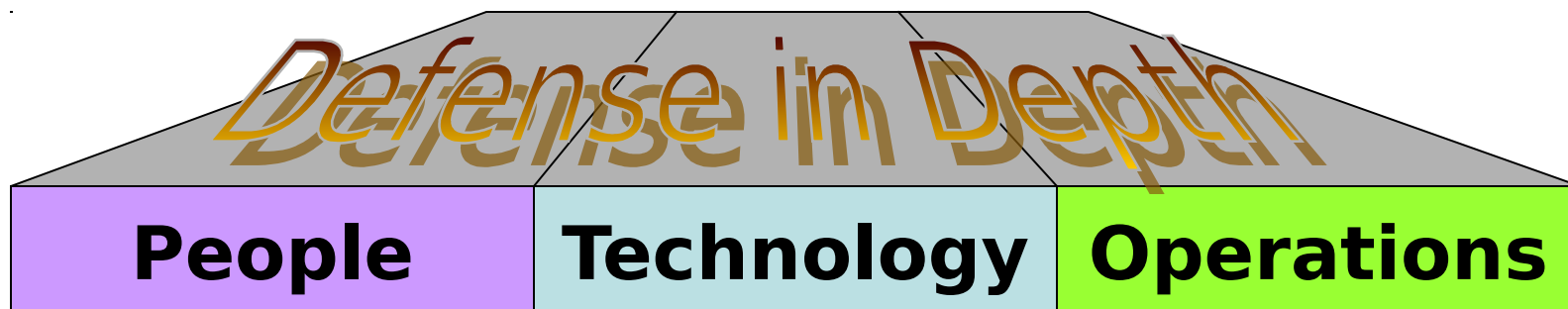

Defend the Network
Defend the Enclave Boundaries
Secure the Computing Environment



Defend the Network

- Communications networks to be defended
 - Satellite
 - 802.11
 - 802.16
- Protection measures
 - Multiple layers of encryption

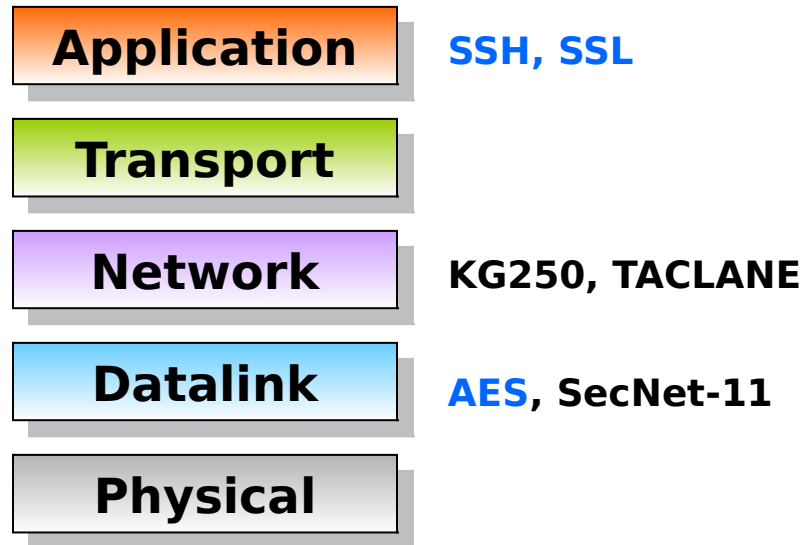

TCP/IP Model

- Network Identification & Authentication



Protect the Boundary

- Firewalls
 - Hardware-based
 - Stateful packet filtering
- Guards
 - Control data flow from Local to Primary suite
 - E.g. scout comms server
- Network monitoring
 - Internal & external connections
 - Host-based IDS
 - Signature-based detection



Secure the Computing Environment (1)

- Identification & Authentication
 - Use approved I&A mechanisms
- Auditing & Logging
 - Log all critical activities
 - Log analysis
- Operating Systems
 - Current EAL4+ systems
 - MS Windows Server 2003
 - MS Windows XP
 - Sun Solaris 9
- File Encryption System



Secure the Computing Environment (2)

- Malicious Code Protection
 - Host-based
 - Virus protection
 - Anti-spyware
 - Firewall
 - Internet connection via Teleport
- Vulnerability scanners
 - Remotely by RCC
 - Vulnerability identification & analysis
 - Password cracker



MLS Technology Research

- Multi-Level Security (MLS)
 - Current
 - Security Enhanced Linux
 - Trusted Solaris 8 (EAL4)
 - Upcoming
 - Active research at Center for Information Systems Security Studies & Research (CISR)
 - Trusted Computing Exemplar (TCX)
- Multiple Independent Level Security (MILS)
 - University of Idaho active in MILS research



Conclusion

- Defense-in-Depth strategy
 - Defend the network
 - Defend the enclave boundaries
 - Secure the computing environment
- Long term plan
 - Incorporate results of MLS research



Modeling

ENS Nick Minerowicz

Maj. Eric Wong



Modeling Outline

- Modeling intro and methodology
- Primary Suite analysis
 - Weights & capability
- Local Suite model
 - Weights & results
- Civil/Military Suite model
 - Weights & results
- Tradeoffs
- Architecture selection



Why Are We Modeling?

- To test assumptions
 - Do the expectations in the CONOPS fall in line with architectures?
- To answer questions
 - How well do the system requirements and our assumptions match up?
- To drive the analysis process
 - How will our results influence the final choice of architecture?
 - Do we meet the key requirements?



What Questions Are We Asking?

- What value is there in a dedicated data link between scouts and the R2C2?
- Does the R2C2 utilize too much bandwidth to share, or is a separate Civil/Military system warranted?
- Does our choice of architecture still fit the two-man transportable requirement?



Methodology

- Analyze the differences between developed architectures using several key criteria
 - Time taken to transmit messages
 - Bandwidth utilization
 - Size / Weight
- Using outputs, determine the architecture that best meets requirements and scenarios



Primary Suite

- The largest two factors driving the selection of a Primary Suite are:
 - The choosing of a satellite terminal that fulfills outlined requirements
 - Developing a system that maintains the two-man transportable objective



PS Satellite Terminals

Sat System	Bands			Weight		Transmit Rate	Receive Rate	License	Power Consumption
	X	Ku	Ka	lbs	# of cases	Mbps	Mbps		W AC
Norsat Globetrekker	optional	yes	optional	<50	1	4	4	Pending	480
Norsat U.P. 5200	optional	yes	optional	46/46	2	8.448	8.448	Pending	480
Swe-dish IPT-i Mil Suitcase	yes	yes	optional	86	1	4	4	Yes	650
TCS DVM-90	no	yes	no	40	1	2.4	2.4	Pending	500
GSI GlobeComm Auto-Explorer (.77m)	no	yes	no	48/50	2	4.2	4.2	Yes Pending	375

While the Swe-dish IPT best meets our objectives, it does so at the expense of weight and power consumption



Primary Suite Weight

Device	Qty	Weight (lbs)
Laptops & Accessories	5	50
Swe-dish IPT	1	86
Swe-dish cabling/support	1	10
Routers	2	28
Switches	3	33
VTC Gear	1	4
VoIP Phones	2	14
SecNet 11 Access Point	1	2
KG250	2	13
Packaging	3	45
Network Cables	1	5
Generator & Accessories	1	50

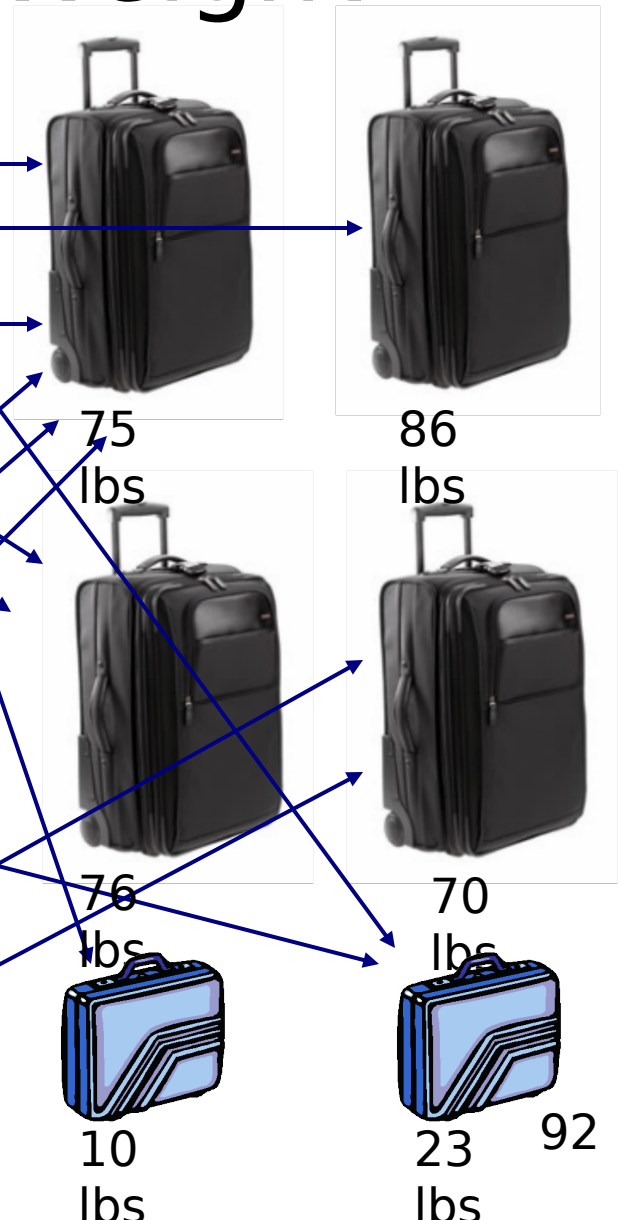



Local Suite Communications

- Two options were explored
 - Voice communication with a data link
 - Data over 802.16 (WiMax)
 - Voice communication without a data link
 - Data via physical transit
- A model was developed following assumptions using scenario inputs and CONOPS development



Local Suite Assumptions

- Basic voice transmissions occur the majority of the time
- There occasionally may be data that needs to be passed back
- The “data link” may be accomplished by a vehicle in some architectures
- All components have electrical power

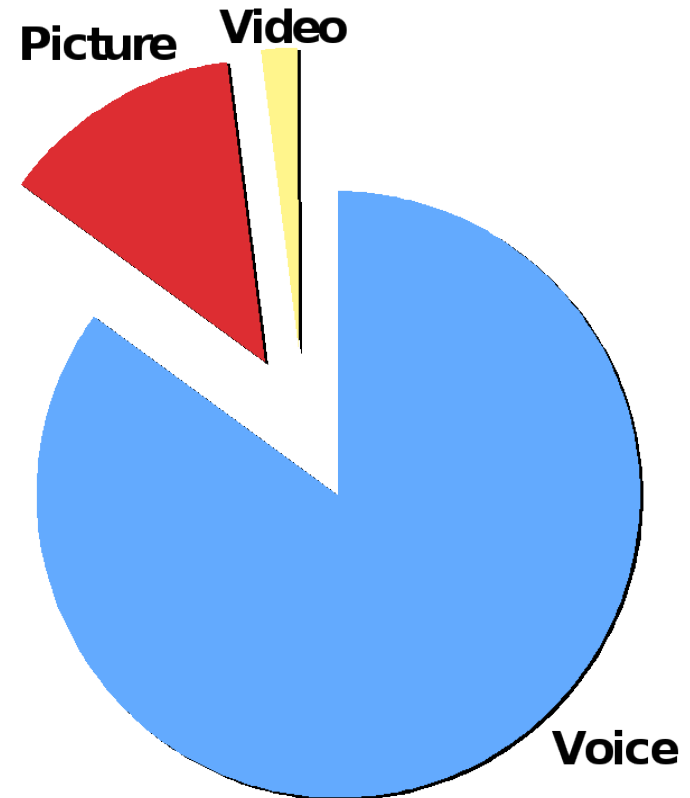



Local Suite Assumptions

- Hourly scheduled communications from scouts
- Scouts are stationed about 35 miles from the R2C2 Primary Suite and have access to vehicular travel



Local Suite Results

Average Message Transmission Time
Over 500 Runs

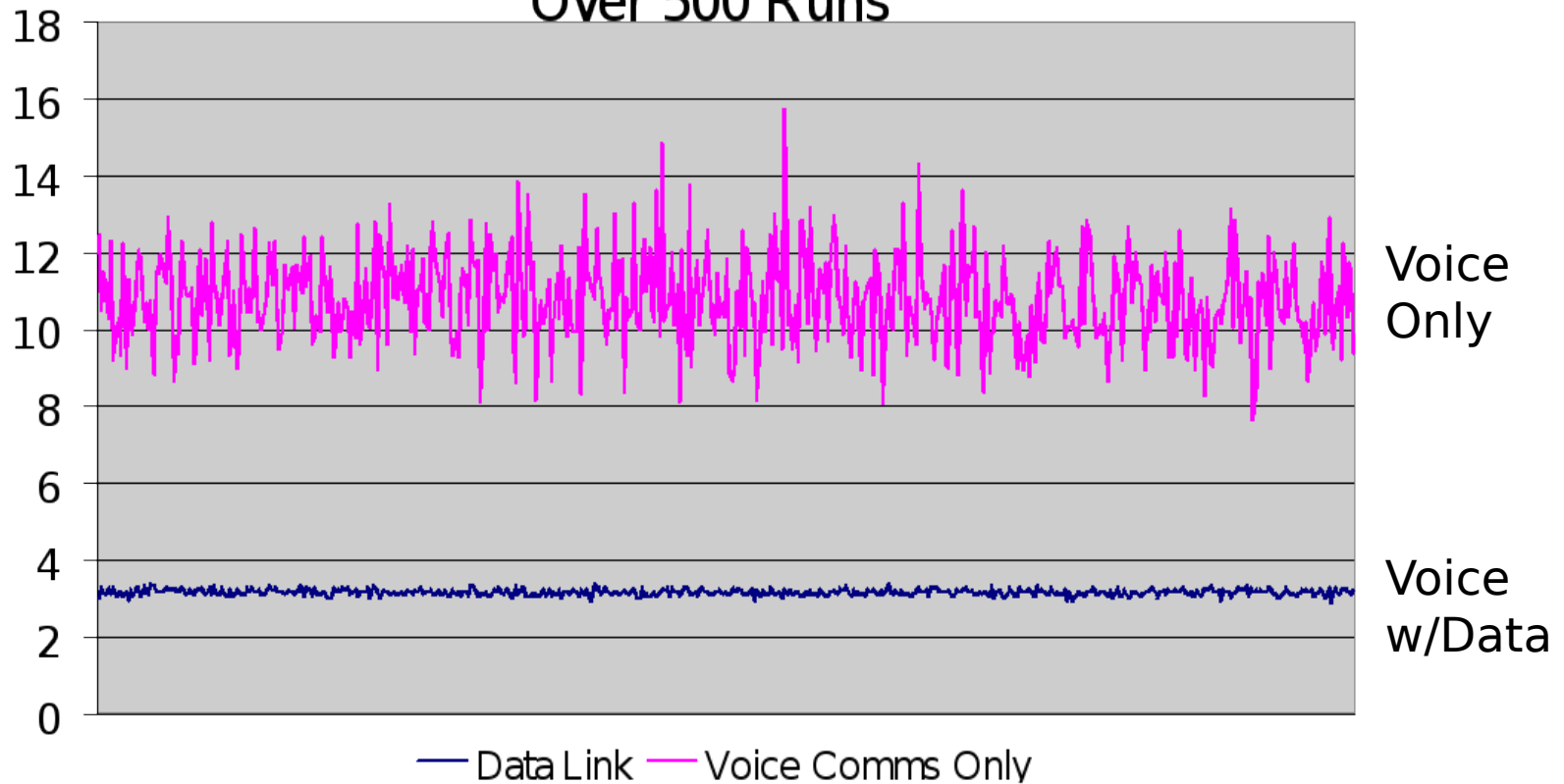

Data transmission delays are larger without a dedicated data link



Local Suite Results

Average Data Transmission Time
Over 500 Runs

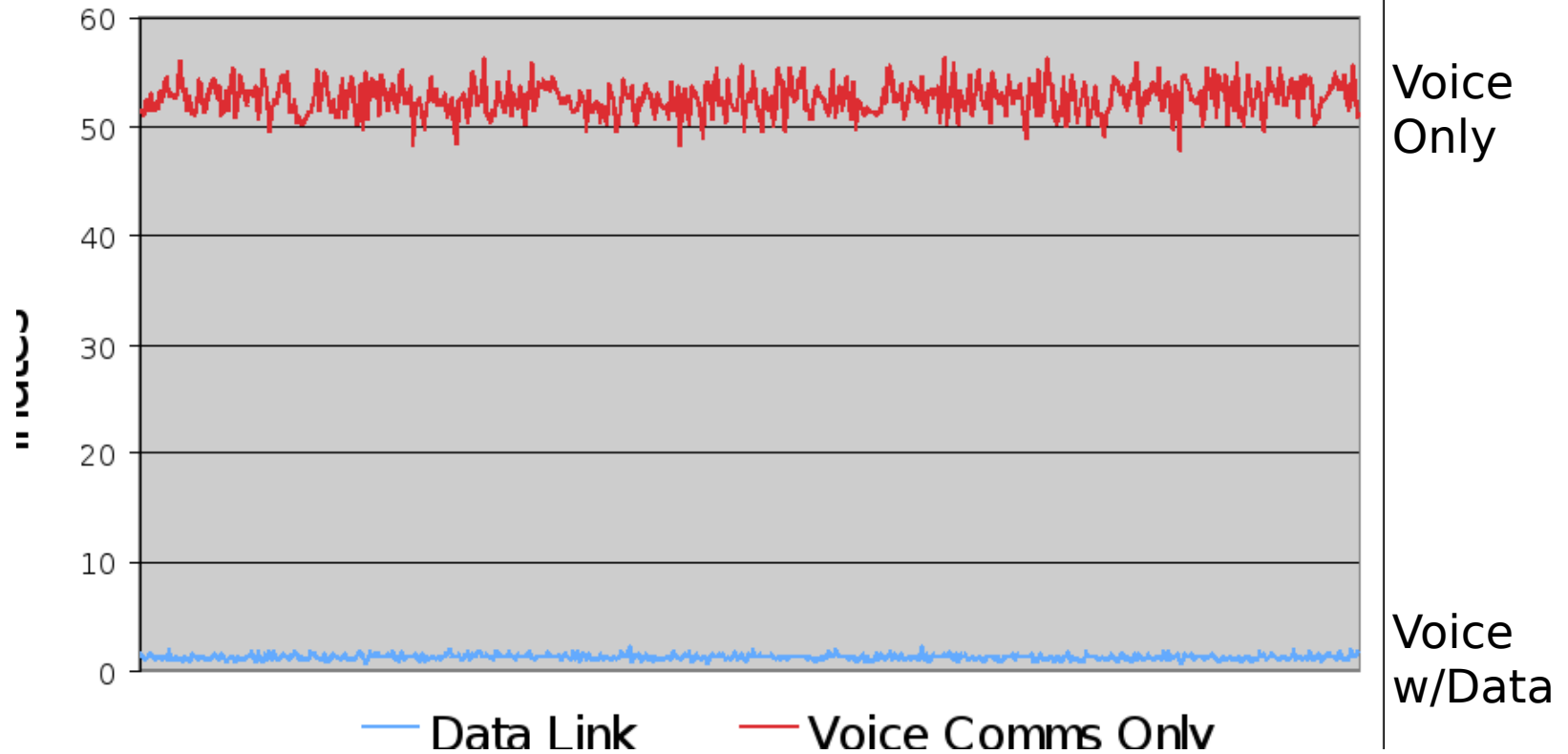

When looking at data transmissions alone, it the difference in delay is approximately 50 minutes



Voice Only Equipment (per scout team)

Device	Qty	Weight (lbs)
Iridium phone	1	0.5
PDA	1	0.5
Digital camera	1	0.5
Video camera	1	1
Package		N/A
Total		2.5

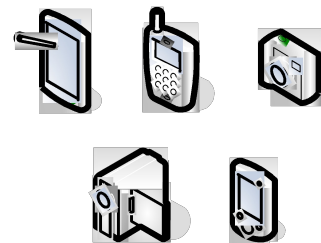
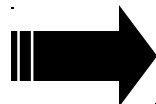

Satellite Phone
Info Collecting Device
2.5 lbs



Wireless Equipment (per scout team)

Device	Qty	Weight (lbs)
Voice Comm.	1	2.5
802.16 Transceiver	1	9
Additional Laptop	1	8
Networking Gear/Cables	1	5
802.16 Antenna	1	5
Package	1	3
802.16 Transceiver	1	9
802.16 Antenna	1	5
Cables	1	5
Total		51.5

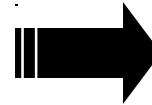

Wireless Equipment
Voice Comm & Info
Collecting Devices
51.5 lbs



Local Suite Recap

Capability vs. Weight Tradeoff

Configuration	Estimated Weight	Characteristics
Voice-only link	2.5 lbs.	<ul style="list-style-type: none">• Slow data transfer• Lightweight
Voice/Data link	51.5 lbs.	<ul style="list-style-type: none">• Rapid data transfer• Heavy

While a data link can rapidly send data, it is done at significant weight increase



Civil/Military Suite

- The need for a dedicated CMS addendum package depended on understanding bandwidth usage of the Primary Suite
- If bandwidth modeling shows a significant excess, then it will not be necessary to provide a separate satellite link



Civil/Military Suite Assumptions

- Data communication to and from the R2C2 is IP-only data
- Continuous electrical power
- Added overhead to account for satellite communications

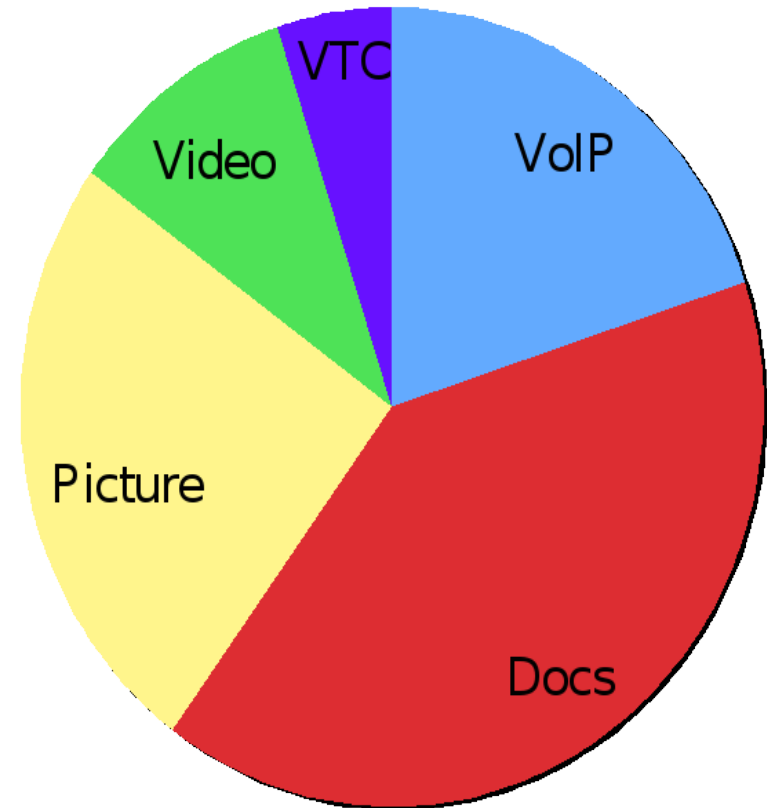



Civil/Military Suite Results

Unused Bandwidth over 500 Runs

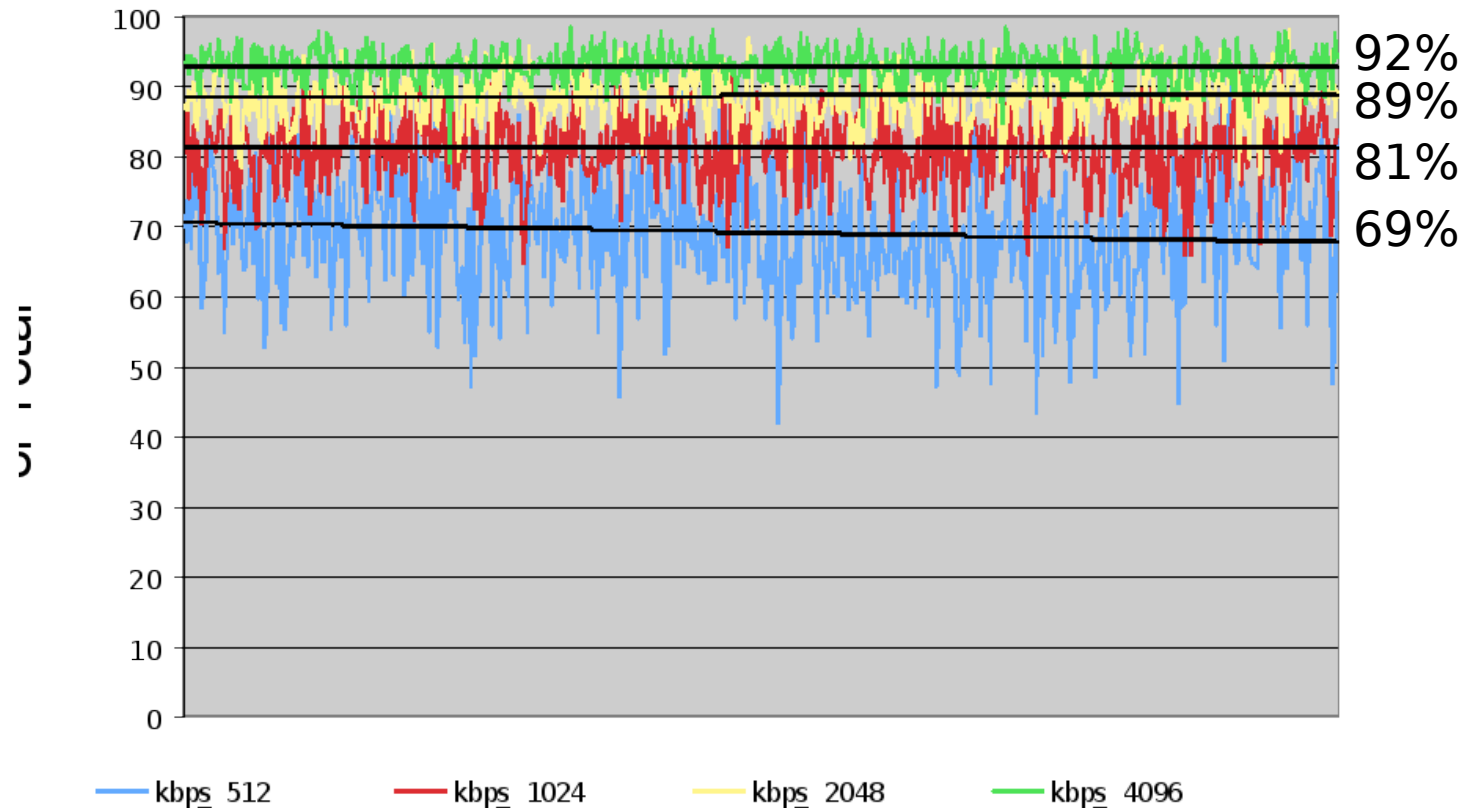

Even with a low uplink bandwidth, the R2C2 CONOPS leave a significant excess to be used by others



Civil/Military Suite Weight

Device	Qty	Weight (lbs)
Generator	1	50
Package	1	10
Cable	1	10
Total		70

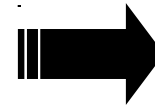

70 lbs

Device	Qty	Weight (lbs)
Norsat Globetrekker	1	50
Package	1	10

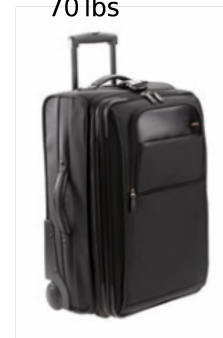

60 lbs

Device	Qty	Weight (lbs)
Laptop	2	16
Cable	1	15
Router	1	5
Package	1	10
Total		46

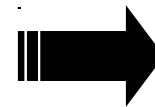

46 lbs



Civil/Military Suite Recap

Capability vs. Weight Tradeoff

Configuration	Estimated Weight Addition	Characteristics
Integrated CMS Suite	0 lbs	Negligible extra equipment needed
Separate CM	106 lbs (+70 lbs generator)	Provides extra capacity

While a separate CMS will provide greater capacity, it is possible to use the integrated solution in most situations



Choice of Architecture

- For standard operations:
 - R2C2 with voice-only communications
 - Integrated CMS
- For time-critical missions:
 - R2C2 with 802.16 data links
 - Integrated CMS



Standard Operations

- El Salvador Scenario
- Pandemic Scenario

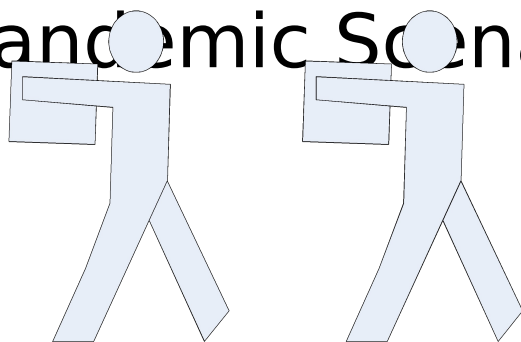

R2C2 Operator

R2C2 Operator



169lbs

171lbs

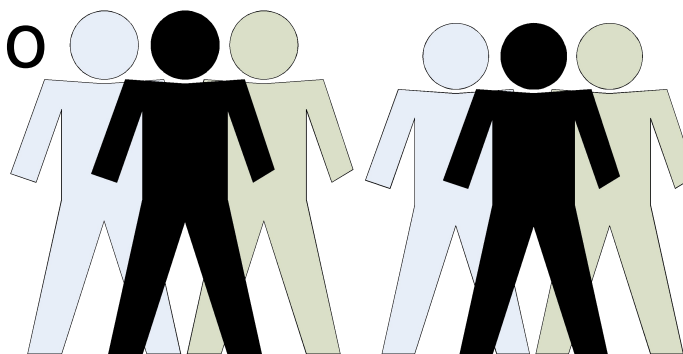

Scout Team

Scout Team

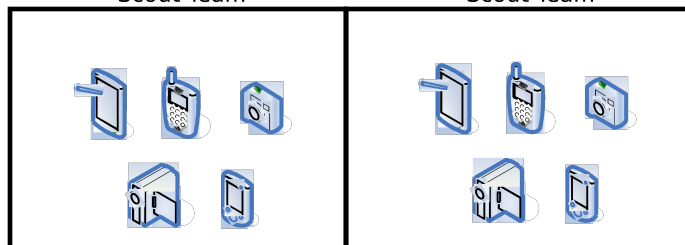

2.5 lbs

2.5 lbs



Time-Critical Operations

- Iran Scenario
- Counter-terrorism Scenario
- Ivory Coast Scenario

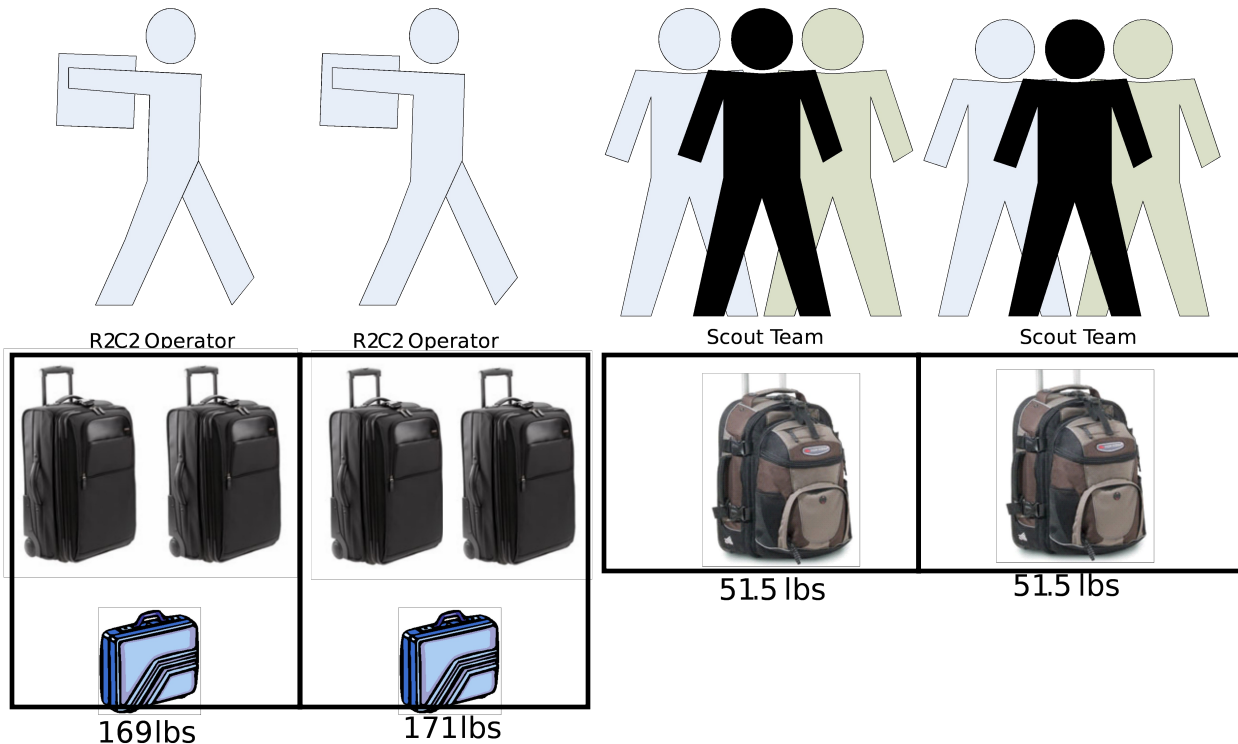



Additional Weight Tradeoffs

Risk	Weight Change	System Weight
Lightweight Packaging (less robust and durable)	-27 lbs	313 lbs
Norsat Globaltrekker (not yet certified for use)	-36 lbs	304 lbs
Operate Without Generator (power supply uncertain)	-50 lbs	290 lbs
Con Dec	Multiple deductions can be combined to reduce weight at increased risk	7 lbs



Modeling Conclusions

- Inclusion of a field-employable data link will drop data transit times by approximately 50 minutes, better enabling time-critical missions
- A separate CMS is unnecessary, as the R2C2 CONOPS do not show more than 50% usage even for low bandwidth rates
- Multiple risks can be taken to further reduce the deployed weight of this system by over 100 lbs



System Analysis

ENS Kitan Bae

Mr. Heng Yue Wong

Mr. Hang Sheng Lim



System Analysis Outline

- Key findings
- Analysis of time-critical R2C2 system architecture
 - Analytic Hierarchy Process (AHP)
 - Baseline for future TEMP
 - COI, MOE, MOS, MOP
 - AHP criteria weighting results
 - Survey taker breakdown
 - Overall results
 - AHP comparison of three systems
 - Traffic light comparison of three systems
 - Review of CPD, BAA, R2C2 team generated requirements
 - Comparison of three systems



Key Findings

- AHP Criteria weights & rankings
- Three system rankings

Criteria	Weight	Method	AHP	Traffic light matrix			
Operation capability	48.1%	System	AHP	Traffic light matrix			
Information Security	25.9%						
Interoperability	17.5%						
Situational Awareness	17.5%						
Technical parameters	34.8%				R2C2	42.7%	27/28
Local Communication	61.5%						
Long haul communication	38.5%						
Integrated Logistic Support (ILS)	17.1%				System Y	28.3%	22/28
Reliability	41.0%						
Maintainability	21.6%						
Spares support	15.2%	JSIC EC2	29.0%	16/28			



Analytic Hierarchy Process (AHP)

- Offers the ability to ‘mirror’ human decision making process
 - Structuring issues in a hierarchy, top-down approach.
- Answers questions such as:
 - Which is the best alternative for your decision problem?
 - Provide insights as to how sensitive are your alternatives/choices to changes in the decision criteria?
- Provides a clear, transparent and objective means of arriving at defensible and credible decisions.
- Current users of AHP
 - U.S. Army, Navy, Air Force, Marine Corps
 - Federal Aviation Administration
 - Department of Agriculture (USDA)
 - Social Security Administration (SSA)



Development of AHP

- Traced back to the scenarios
- Identified Critical Operation Issues (COI)
 - Measure of Effectiveness (MOE)
 - Measure of Suitability (MOS)
 - Measure of Performance (MOP)
- Transform developed parameters into AHP comparison criteria
- Determined the weights of each criterion
 - Various working group survey
- Conduct 3 system comparison



COI Breakdown



1. Communication
2. Deployability
3. Interoperability
4. Provide Situational Awareness
5. Information Security
6. Mission Flexibility
7. Reliability
8. Maintainability
9. Human Factor

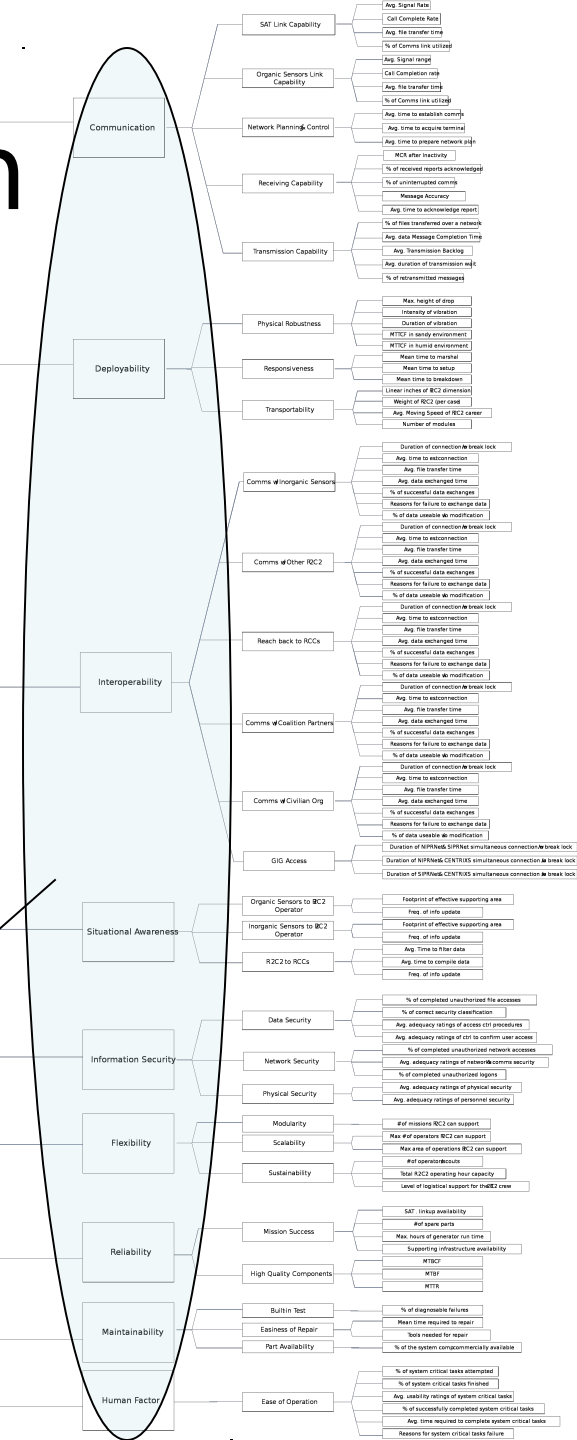



COI Breakdown

1. Communication
2. Deployability
3. Interoperability
4. Provide Situational Awareness
5. Information Security
6. Mission Flexibility
7. Reliability
8. Maintainability
9. Human Factor

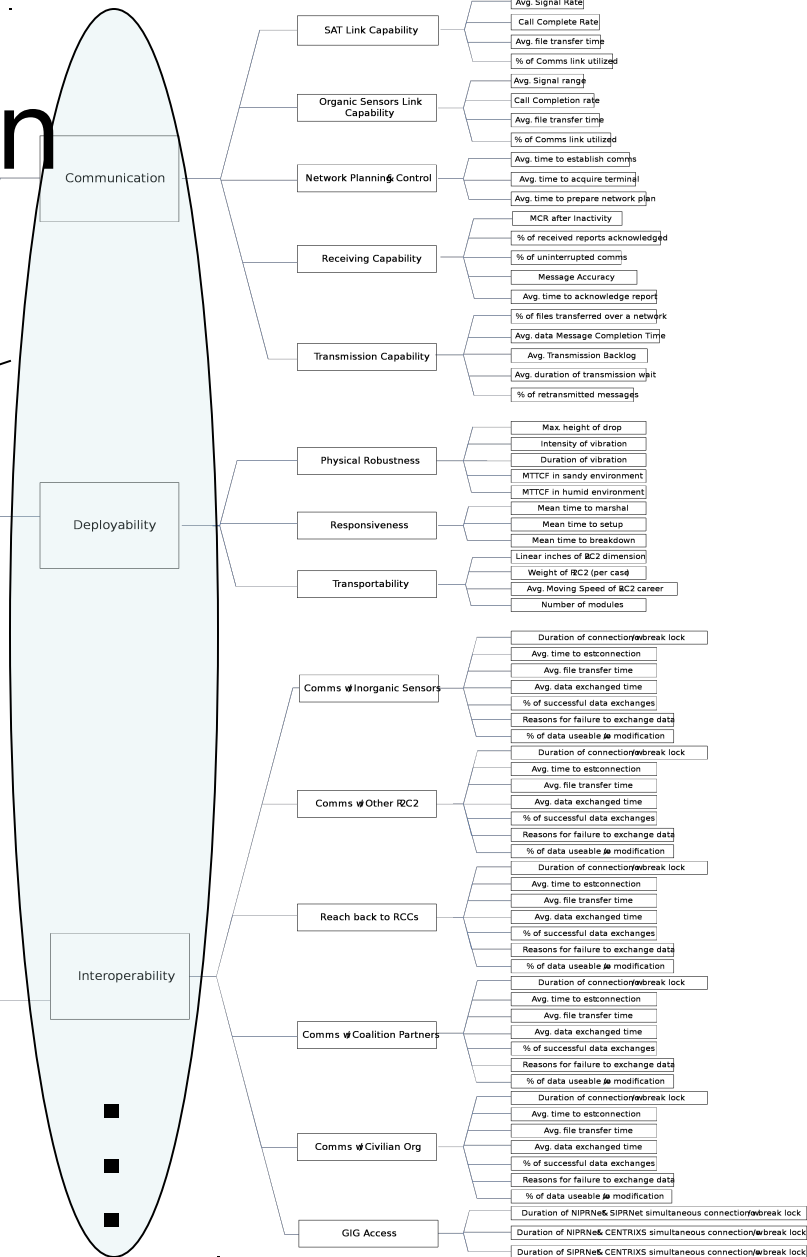



Function

Communication

Capabilities

SAT Link Capability

Organic Sensors Link Capability

Network Planning & Control

Receiving Capability

Transmission Capability

MOPs

Avg. Signal Rate

Call Complete Rate

Avg. file transfer time

% of Comms link utilized

Avg. Signal range

Call Completion rate

Avg. file transfer time

% of Comms link utilized

Avg. time to establish comms

Avg. time to acquire terminal

Avg. time to prepare network plan

Message Completion Rate after Inactiv

% of received reports acknowledged

% of uninterrupted comms

Message Accuracy

Avg. time to acknowledge report

% of files transferred over a network

Avg. data Message Completion Time

Avg. Transmission Backlog

Avg. duration of transmission wait

% of retransmitted messages



AHP Comparison Criteria

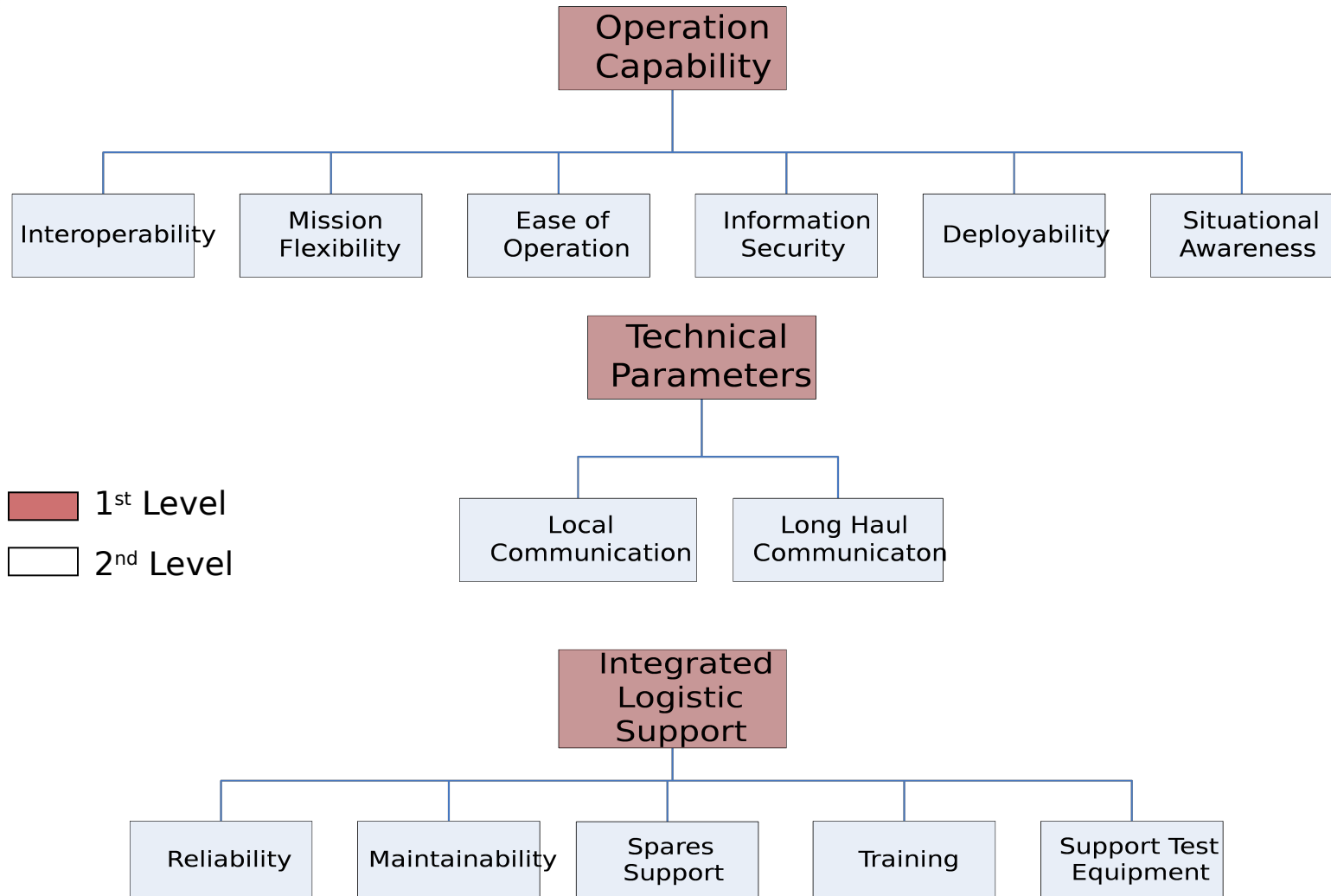



AHP Weights

- Method:
 - Campus-wide AHP survey to collect individual judgment
 - Required minimum of 30 samples to achieve statistical significance
 - Every criteria was compared to each other for relative importance
 - Saaty's intensity of importance scale was utilized and averaged geometrically
 - Four different groups were surveyed & compared

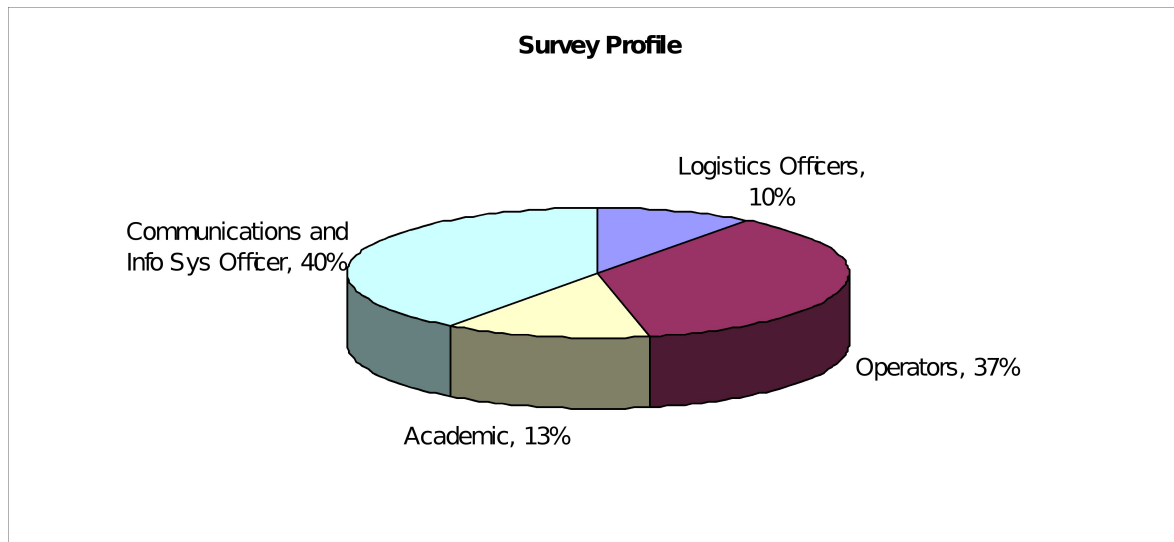



Saaty's Intensity of Importance Scale

Intensity of importance	Definition	Explanation
1	Equal importance	Two activities contribute equally to the objective
3	Weak importance of one over another	Experience and judgment slightly favor one activity over another
5	Essential or strong importance	Experience and judgment strongly favor one activity over another
7	Demonstrated importance	An activity strongly favored and its dominance demonstrated in practice
9	Absolute importance	The evidence favoring one activity over another is of the highest order of affirmation.
2,4,6,8	Intermediate values between the two adjacent judgments	When compromise is needed.
Reciprocals of above non-zero numbers	If activity i has one of the above non-zero numbers assigned to it when compared with activity j , then has the reciprocal when compared with i .	



1st Level Criteria Difference Between Groups

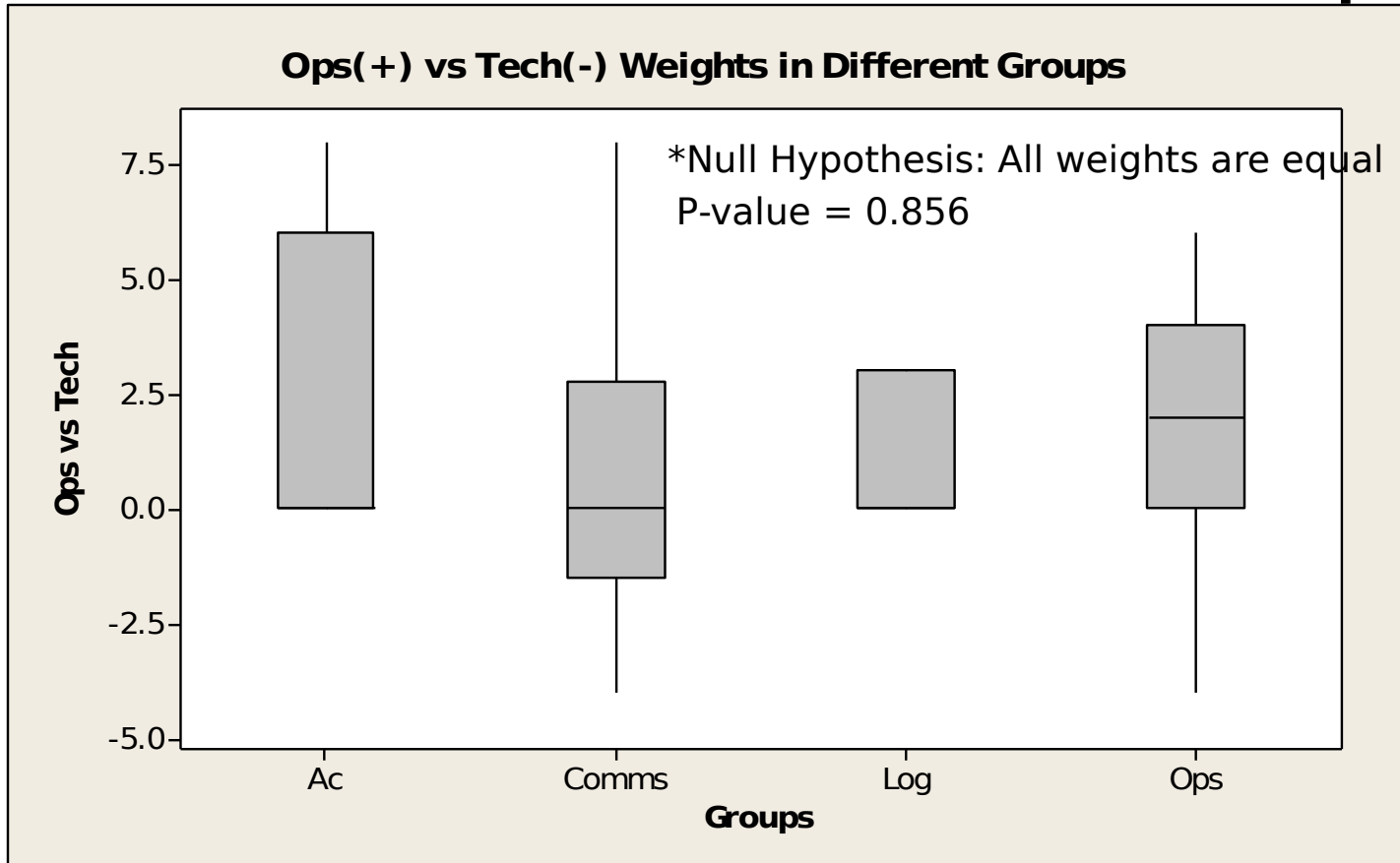

No statistical difference between the groups



1st Level Criteria Difference Between Groups

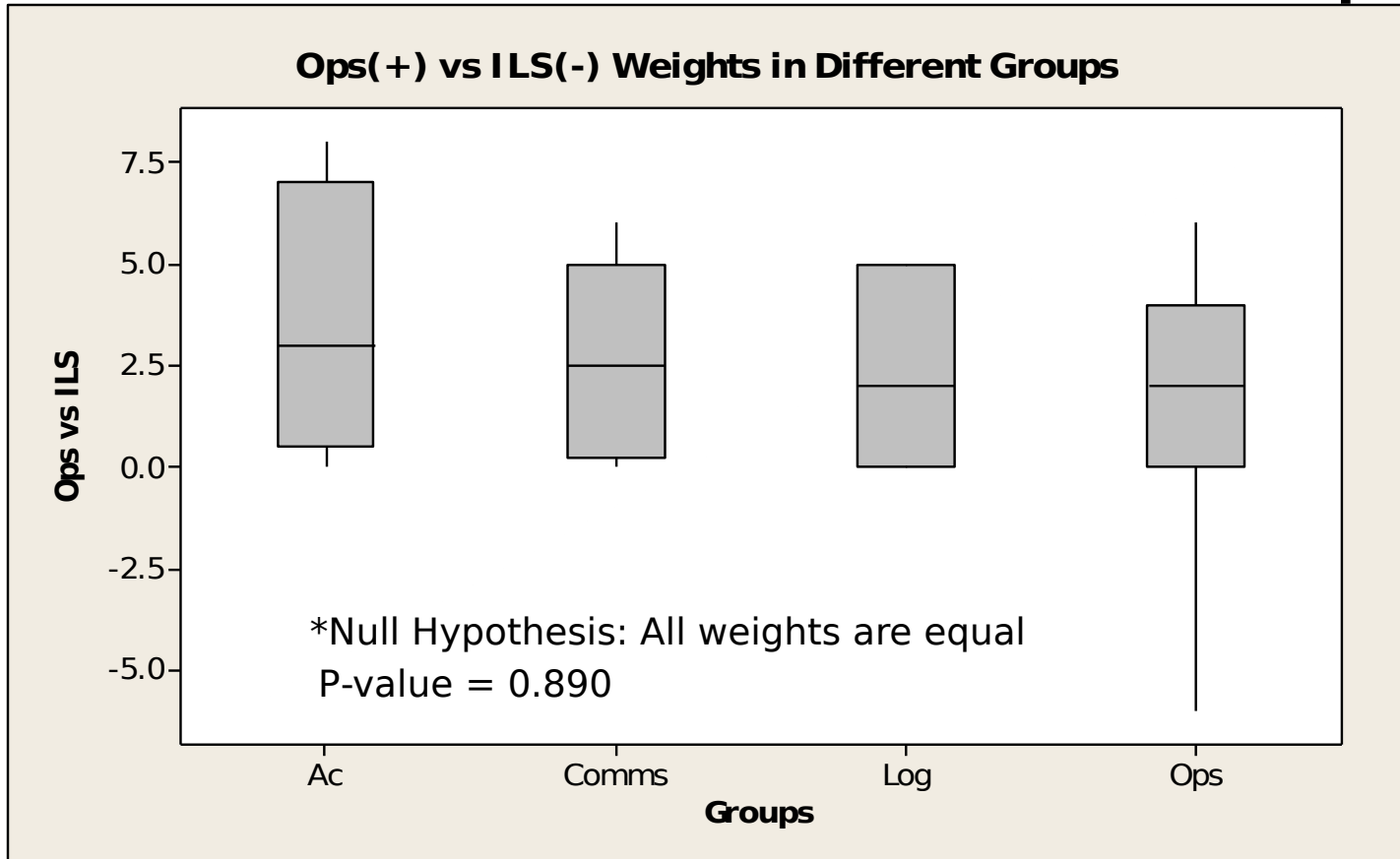

No statistical difference between the groups



1st Level Criteria Difference Between Groups

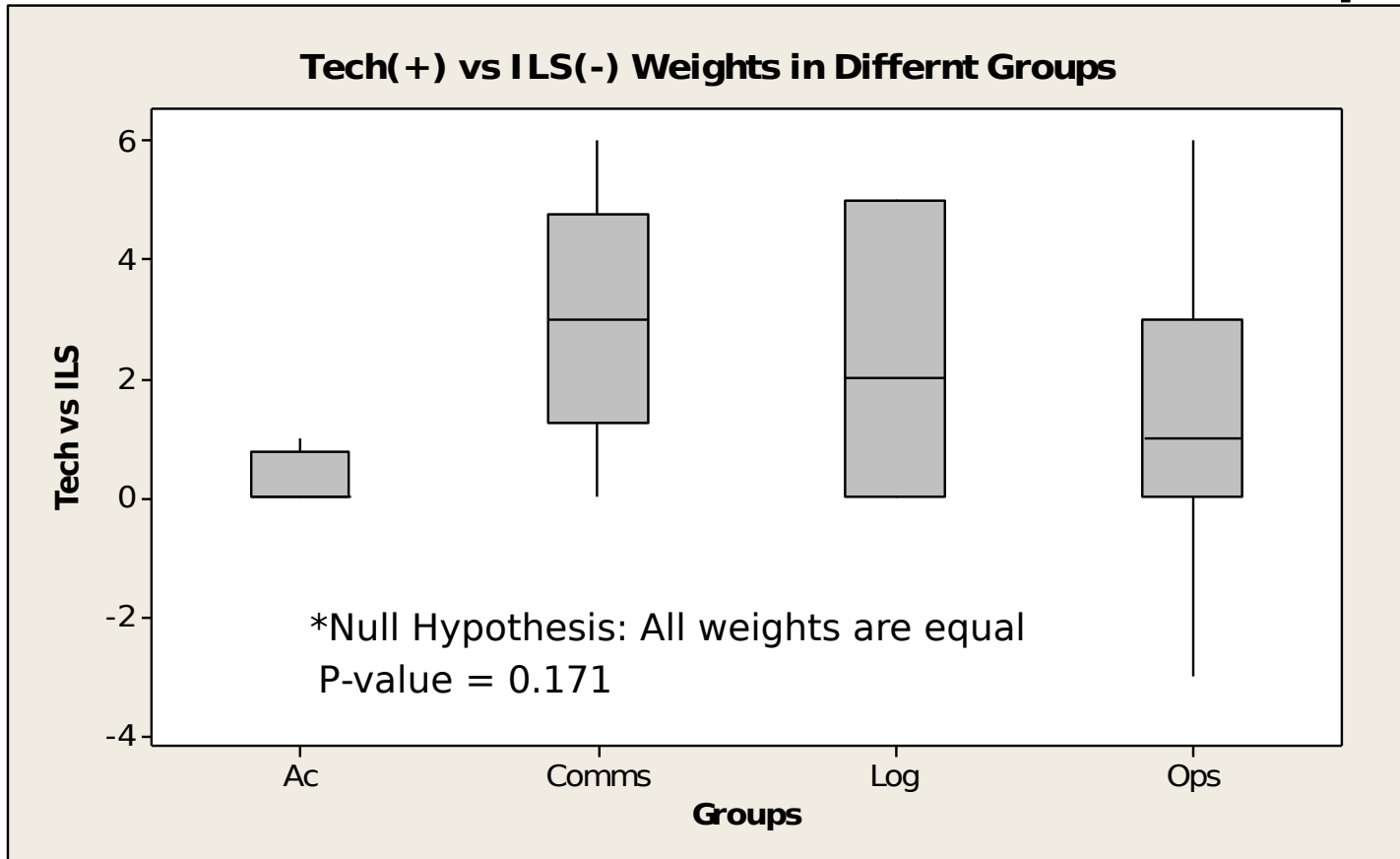

No statistical difference between the groups



The Overall Results

1st Level Criteria

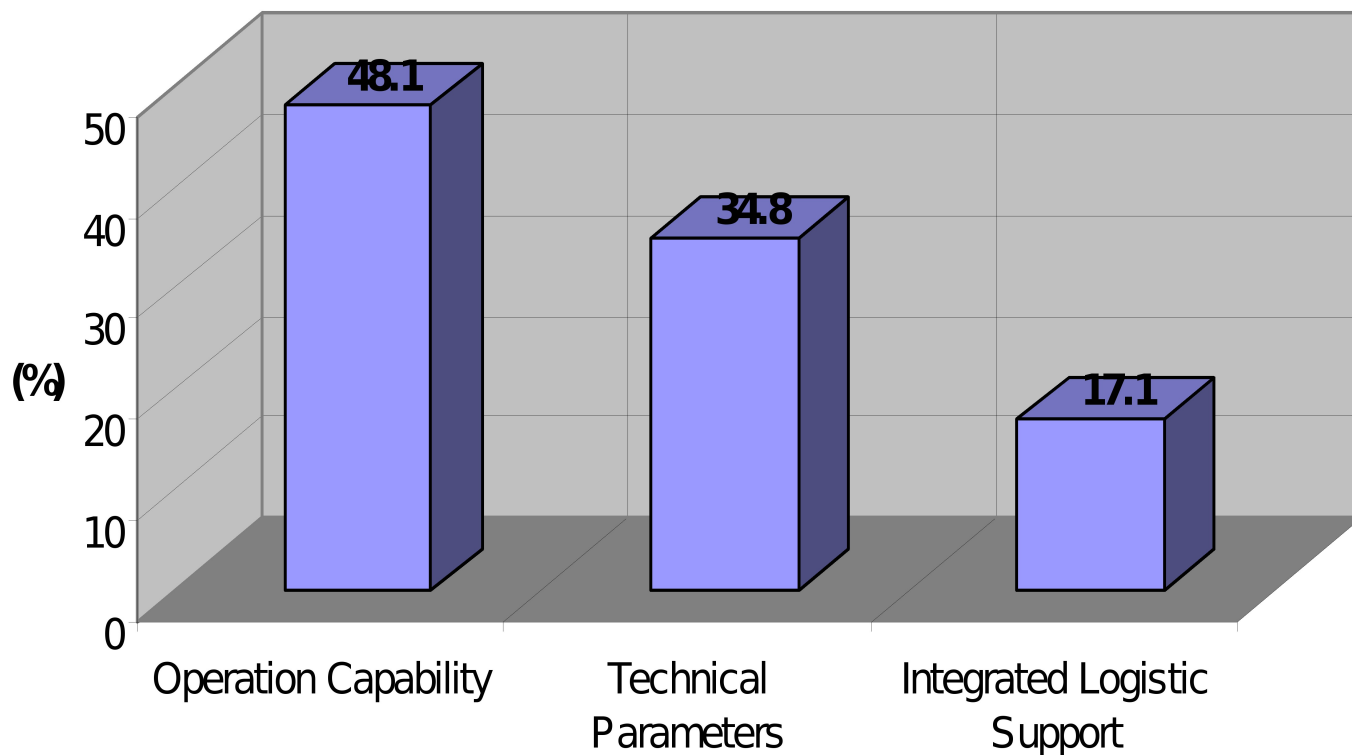

EC2

Sys Y

R2C2



Ops 2nd Level Criteria

Interoperability & Situational Awareness were ranked the 2nd

Ops Capability 2nd Level Criteria

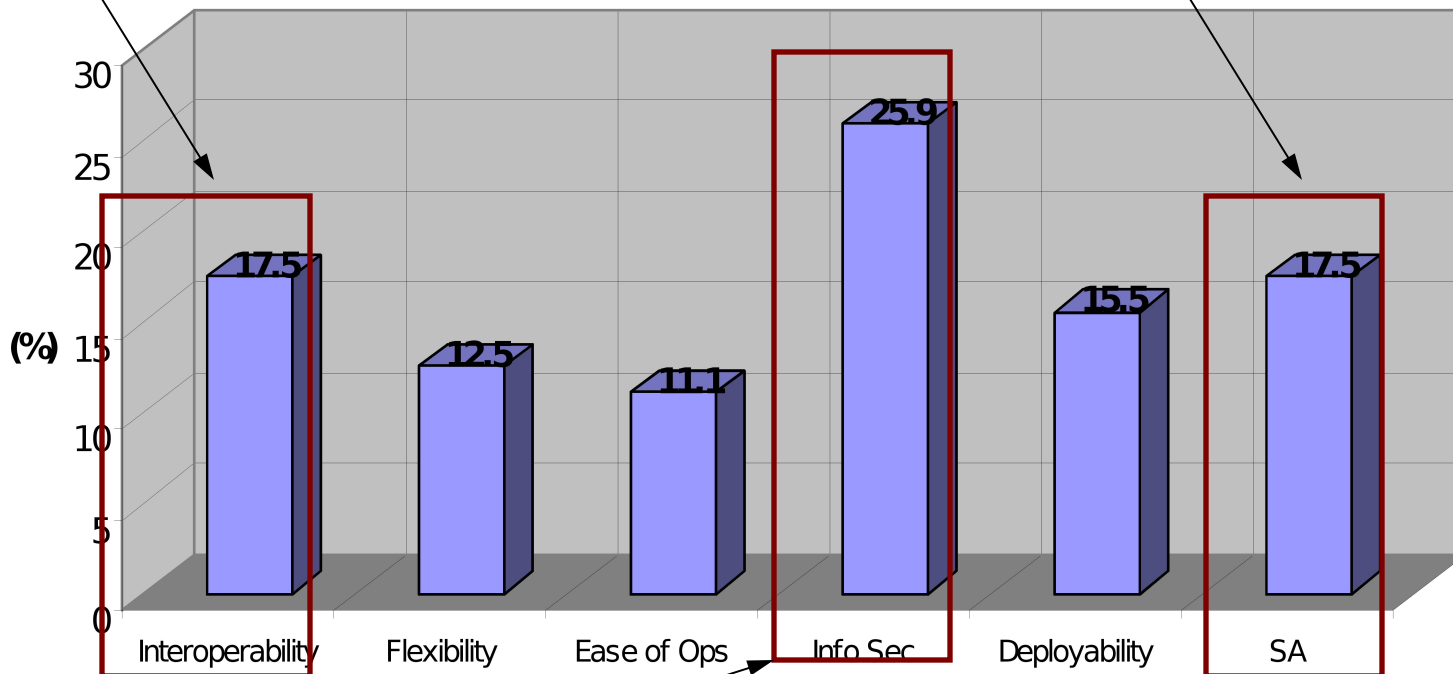

Information Security is the most important cr



Technical 2nd Level Criteria

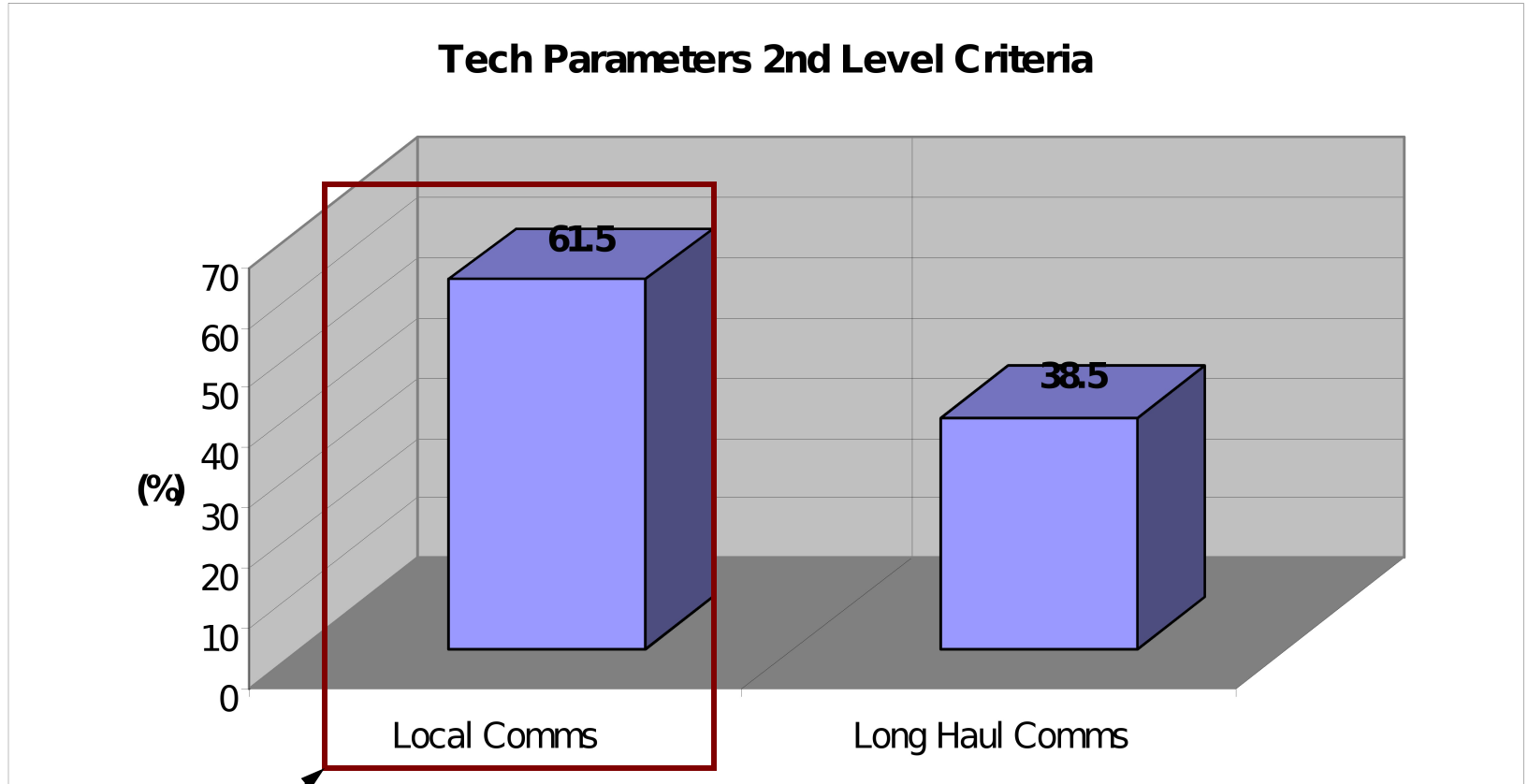

Local communication was more heavily weighted



ILS 2nd Level Criteria

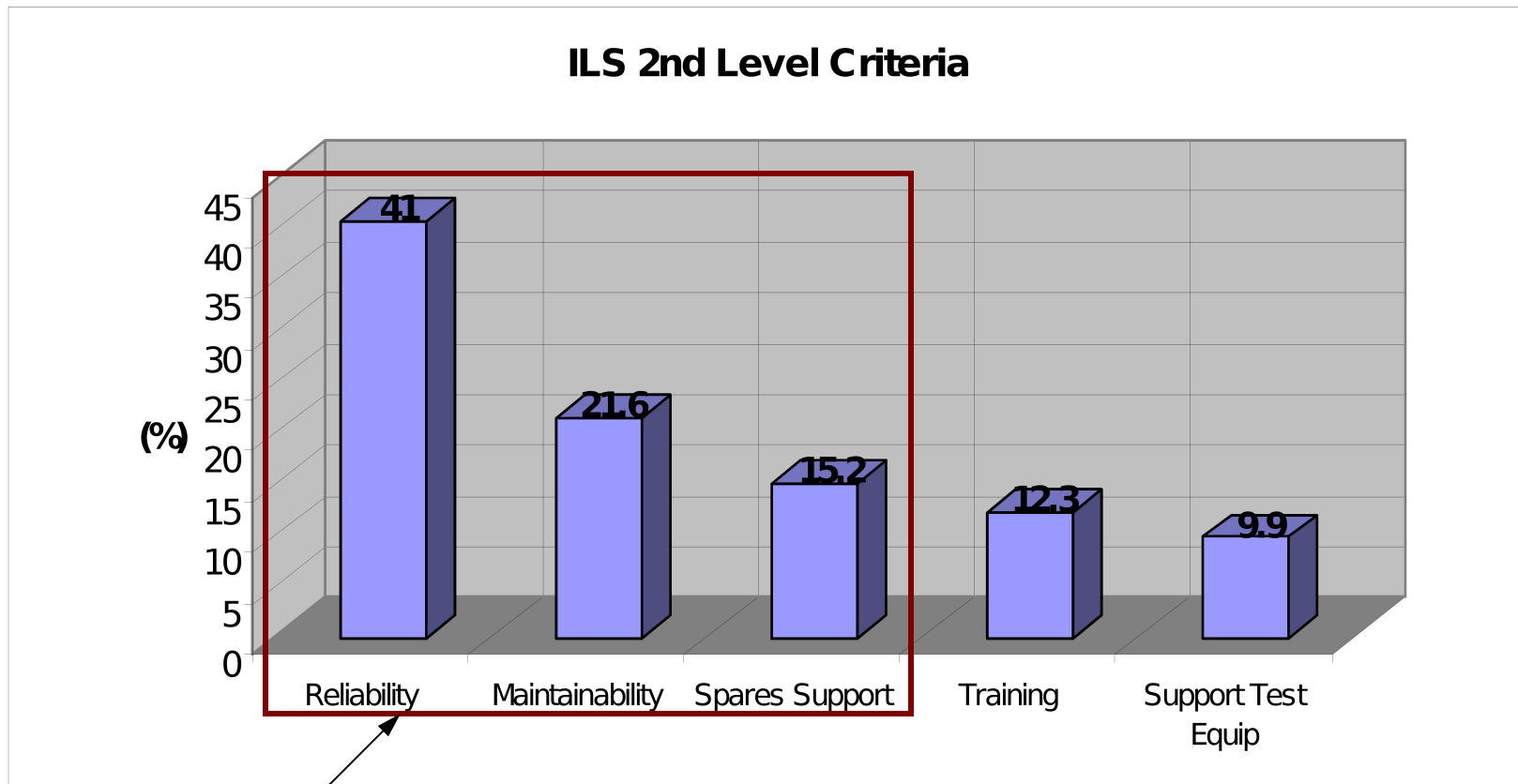

Reliability → Maintainability → Spares Support



Three Systems

- Executive Command & Control (EC2)
 - Developed in 2003 by Joint Systems Integration Command (JSIC)
 - Designed to provide RCCs and JTF commanders capability to host services on classified and unclassified networks to maintain situational awareness
 - Consists of laptops, routers, and other pieces of equipment that can be easily packed in a hard case
- System Y
 - One of the proprietary systems being proposed to DJC2 office in response to RRK requirements
 - Similar to R2C2 without the local communications capability
- Rapid Response Command & Control (R2C2)
 - Included the Primary, Local, and Civil/Military suites to provide long haul communications and reachback capabilities to the RCC, wireless data link capability for SA, and civil/military links



C20TM, System Y, and R2C2

EC2 has the best logistic support

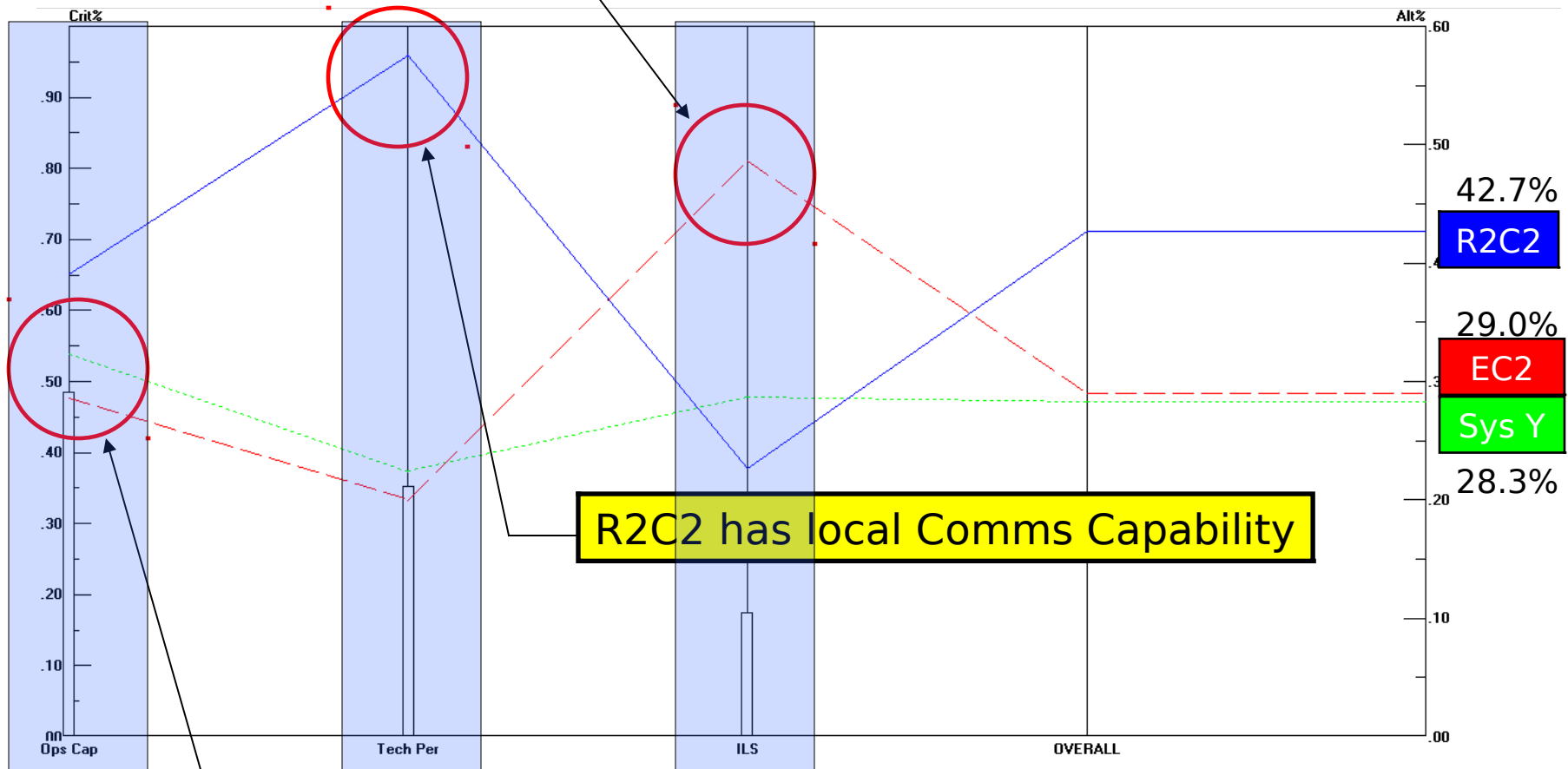

R2C2 has local Comms Capability

System Y has better operation capability over EC2



JSIC EC2, System Y, and R2C2 System Requirements Matrix

(1)

■ CPD
 ■ BAA
 ■ R2C2

	JSIC EC2	System Y	R2C2
State of the art agile and self contained			
Two Person Transportable			
Small footprint (Physical)			
Transportable in commercial and military aircraft			
Collaboration via reachback			
Marshall in 30 minutes			
Operational in 30 minutes			
Local physical storage (on one or more laptops)			
Transportable by commercial air or ground by two men			
Operable on standard electrical power			
Provide data and voice communications			
Support and Training Documentation			
Connect to commercial internet			
Provide secure means, physical security, data security, and network security, of passing tactical information to supported commander for situation assessment.			
Provide compact, rugged and mobile packaging.			
Provide flexibility for mission dependent software and hardware configurations.			



JSIC EC2, System Y, and R2C2 System Requirements Matrix (2)

■ CPD
 ■ BAA
 ■ R2C2

	JSIC EC2	Sys Y	R2C2
Satellite Connectivity	Yellow	Green	Green
Able to operate in austere locations	Yellow	Yellow	Green
Two Simultaneous Data Networks	Red	Green	Green
Limited rapid response communication capability to include: UHF TACSAT, INMARSAT, SHF SATCOM, Global Sat. Phone	Yellow	Yellow	Yellow
Wireless (objective)	Yellow	Green	Green
Utilize EOIP to include VTC	Yellow	Green	Green
Multi-Mode Operations (voice, data and video simultaneously)	Yellow	Green	Green
Provide 1.024 Mbps Threshold per Network (4.096 Mbps Objective)	Yellow	Green	Green
Provide capability of local and long haul communications	Yellow	Yellow	Green
Provide means of collecting data from organic or inorganic assets	Yellow	Yellow	Green
Provide self-supporting power supply in addition to capacity of operating on standard electrical power	Yellow	Yellow	Green
Provide capability for operators to receive, display, analyze, filter and pass simultaneous data from organic or inorganic assets	Red	Red	Green

Number of Requirements Met :
 16/28
 22/28
 27/28



Analysis Conclusions (1)

- AHP
 - Provided baseline for future Test and Evaluation Master Plan
 - Provided rankings of evaluation criteria
 - No statistical significant difference between the groups
 - Local communications ranked higher than Long Haul

Operation capability	48.1%
Information security	25.9%
Interoperability	17.5%
Situational awareness	17.5%
Technical parameters	34.8%
Local comms	61.5%
Long haul comms	38.5%
Integrated Logistic Support (ILS)	17.1%
Reliability	41.0%
Maintainability	21.6%
Spares support	15.2%



Analysis Conclusions (2)

- Traffic light comparison of three systems
 - Verified that R2C2 system met most of the requirements
 - Identified R2C2 to be the most suitable system

	AHP	Traffic light matrix
R2C2	42.7%	27/28
System Y	28.3%	22/28
JSIC EC2	29.0%	16/28



Conclusions

LCDR Lisa Sullivan



Project Conclusions (1)

- Analyzing decision making tools revealed that the results were consistent and that R2C2 outperformed other systems
 - R2C2 ranked highest in the AHP with 42.7% and captured the highest number requirements, 27 of 28
- Performing operational assessments of mission and environment determined if the operation was time-critical
 - 3 of 5 of the R2C2 briefed scenarios are time-critical
 - Requires additional 50 lbs of data link equipment per scout team
- Conducting additional weight calculations reduced the Primary Suite by 113 lbs, but not without potential risks



Project Conclusions (2)

- Utilizing a top down approach for developing requirements guaranteed traceability to strategic guidance and identified additional requirements for the system
- Capturing the needs of multiple users working in different missions and environments required in depth mission analysis and development of many scenarios to cover the broad spectrum of potential operations



Project Conclusions (3)

Due to modular design, the R2C2 provides the RCC with required flexibility and scalability to delivery a rapidly deployable command and control system to meet the range of military operations

Questions?





Back-up Slides



Weight Assumptions

- Airline Standard
 - Checked Luggage:
 - 62 linear inches
 - 100 lbs
 - Carry-on:
 - 45 linear inches
 - 50 lbs
- MIL-STD-1472F
 - Checked Luggage:
 - 18" wide x 18" high x 12" deep
 - 45% of body weight (Approx. 80 lbs) for marching
 - Carry-on:
 - Airline weight restriction is limiting factor in most cases