

# ORDER LOGISTICS FOR DISCRETE AND CONTINUAL PRODUCTION PROCESSES IN INDUSTRY 4.0 CONDITIONS

Received – Prispjelo: 2020-08-29

Accepted – Prihvaćeno: 2020-10-30

Original scientific paper – Izvorni znanstveni rad

The basic goal of the article is to define changes in production logistics and its essential part of order logistics at the transformation of the production system from an automated management system with the participation of first level logistics, managers and machine operators to a fully automated, unattended production system and at the same to define and compare the differences between discrete and continuous-discrete production typical for mining, metallurgical production processes. The solution applied the methodology of comparative analysis of the comparison of current systems of order logistics [1, 2], and its operation in terms of Industry 4.0. There were applied principles of production planning and programming of numerical control (NC) machines and robots and program-controlled fully automated production processes, especially in the continuous character of processes for the design of a new algorithm of custom logistics [3].

*Keywords:* industry 4.0, management, logistic, order, aggregate production planning

## INTRODUCTION

Industry 4.0 is one of the fundamental subsystems of the Fourth Industrial Revolution dealing with industrial production. Industry 4.0 is the next phase of manufacturing automation, based on the application of cybernetics and physical (technological) interconnection solutions, the application of the industrial Internet of Things (machines), cloud computing, artificial intelligence and other new science knowledge. The result of this phase of automation should be an “intelligent factory” [4-7].

It is created by operational production plans, monitoring and controlling of computer systems technological processes, through digital twin simulation of the course and results of production processes and it provides flexible decentralized management of their course in modularly structured factories, based on artificial intelligence of created models.

Industry 4.0 cannot be implemented without an appropriate level of industrial digital logistics that plans, coordinates, organizes and manages this flexibly-operatively system [4-6,8,9]. The article deals with changes and proposals for automation of one of the basic activities of production logistics. So called “Order logistics» deals with the process from the entry of orders into the information system of the company, through technological, material, capacity and economic appraisal, their processing into internal orders, operational production plan-

ning (cyber subsystem) and its transfer to the implementation of technology, transport and handling, storage operations and decentralized management systems of production centres (physical subsystem) [10,11].

Industry 4.0 brings space to create various applications that contribute to the growth of mutual cooperation, efficiency, resisting fluctuations in market requirements, or reducing business costs. Creation of online platform called the Cyber Industry Network (CIN), shared by many regional SMEs, which controls the available production capacity among involved companies, has a great importance to them. At the same time, the CIN platform enables the sharing of production capacities in the event of a shortage or surplus through a direct connection with the order logistics of each participating company [12,13]. The proposed algorithm, which is introduced in this article below (Figure 1), could become as a part of such systems.

## METHODOLOGY OF RESEARCH IN THE ORDER LOGISTICS

The flow chart of the order logistics describes the model of automation order flow in a company from their records to confirmation of purchase contracts and their preparation for operational planning models. This phase of production logistics can significantly influence the efficiency of the production process, it is not only the administrative processing of orders, but also part of the tactical management of the company [1]. The flow chart of order logistics in Industry 4.0 is shown in Figure 1.

**Creation of order database:** Orders are received in the company continuously. The set of orders for the next

D. Malindžak, Technical University of Košice, Slovakia, dusan.malindzak@tuke.sk,

P. Kačmár, Technical University of Košice, Slovakia

A. Gazda, Rzeszow University of Technology, Poland

E. Mihaliková, Pavol Jozef Šafárik University in Košice, Slovakia

planning period –  $T_N$  are closed regularly in a certain date before the start of the planning period. The order can request one or more product types. If the products are tied to the same delivery date for the same customer, this is called a so called “business case”. A customer can contact the manufacturer by e-mail, telephone, fax, letter, etc. (especially new customers).

Orders are registered and a record is created for each order-product, in an order file (database). Regular customers order goods within long-term contracts. Irregular customers order goods within the operational plans period. Result of this process is creation of an order database.

**Technical, technological and economic assessment:** Recorded orders must be appraised in technical and technological terms. There are technological process data in a file for each product manufactured before. It is one of the basic information files for production logistics. It defines sequence of production operations, their operating times, quantity and type of material used and other qualitative and quantitative data of a certain product.

If the product was manufactured in a company, it should have a technological process data and it can be produced from a technological point of view (if the conditions are not changed). If the product is new, the technical and technological conditions (block 2) for its production are defined by a man. All previous steps can be performed automatically.

**Aggregated (capacity) planning:** There are two approaches of the capacity planning.

a) **Model of the capacity planning with customer orientation**

The particular ordered product has its own production process which also determines the pro-

duction cycle, i.e. minimum time from the beginning of the production process to its completion. It must be included in advance on the production sections when placing the order into the planning period (month, week), that precede the last section so that the delivery date finish its production process

b) **Maximum production model**

However, a different approach is also possible. Ordered products are not assigned to planning periods, but a sequence from orders according to the delivery date is created. There are taken only the part of products from this sequence that a bottleneck of the production process is able to execute in this planning period. Other orders are pushed to following periods. This approach avoids of capacity smoothing. It should be noted that the bottleneck of the production process can vary according to the product range and quantity of the products ordered.

Orders become real contracts after the capacity planning. Material balance is carried out to determine the need for particular raw materials, materials, semi-products, preparations, accessories, etc.

Both models are fully automated today. The management decides which model is applied (it is a strategic decision).

**Cummulation, dosing, prioritization:** There can be combining the same products from different orders into larger groups according to a certain criterion within the same planning period ( $T_N$ ). This achieves greater series and productivity of work and this activity is called cummulation of products.

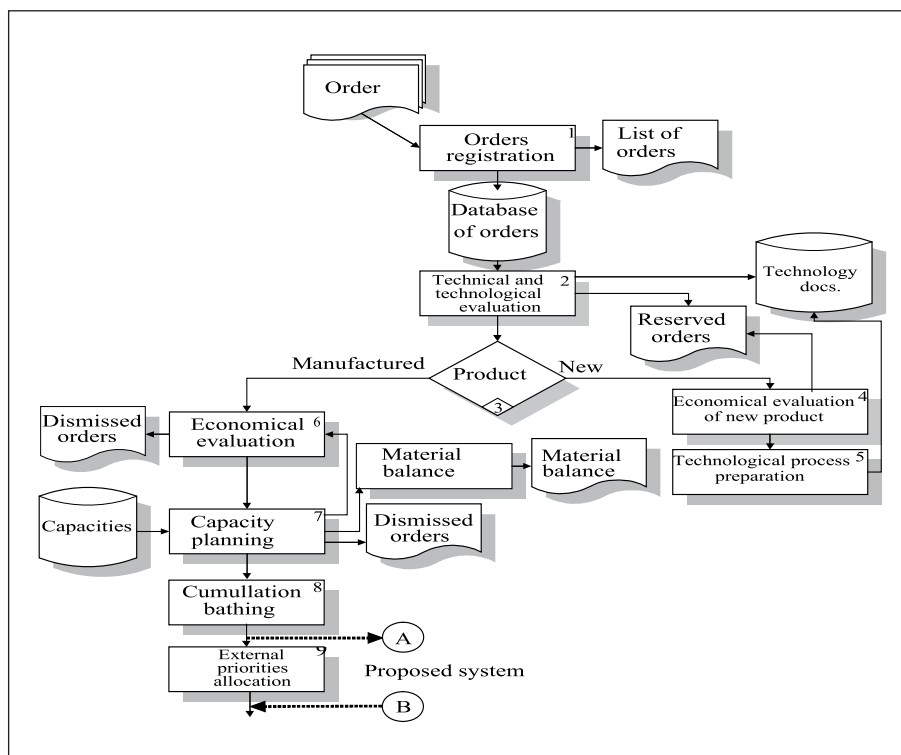

Figure 1 The flow chart of the automation of the custom logistics process [1]

A batch is a certain amount of products that are moved together among operations that are produced at the same parameters. The optimum batch size for a single device in a manufacturing process may vary. The dose is sometimes given by technology.

## RESULTS OF RESEARCH - AUTONOMOUS MANAGEMENT OF INTEGRATED PRODUCTION SYSTEM (IPS)

Production processes in Industry 4.0 are integrated into IPS (machines, robots, manipulators) (Figure 2). IPS is technologically oriented to individual product  $I$ . The control system of IPS (CSIPS) responds to the operational production plan presented by the product number  $I$  and the quantity of products  $I(Q_i)$ . IPS has the features of reconfiguration - rebuilding of devices according to product type  $I$ , flexibility-choice of control programs of autonomous control of individual devices from the controlling library of technological processes (CLTP) for individual products, devices ( $M_i$ ), input and output buffers ( $IB$ ,  $OB$ ). Control of service devices (robots, manipulators) is derived from machine control and coordination among machines and CSIPS.

The basic change of order logistics in Industry 4.0 and thus also in production logistics is in discrete production:

- It moves to a higher level of automation from the level of individual machine control to the entire custom logistics system i.e. from the moment of receiving of orders, through the process of technological, material, capacity and economic assessment and creation of an operational production plan and production schedule.
- Due to the change in the layout of production equipment into the IPS, the reconfigurability of the physical and cybernetic system, autonomy, artificial intelligence and the understanding of each product as a separate production task eliminate the phase of complex production scheduling that is transferred to CSIPS.

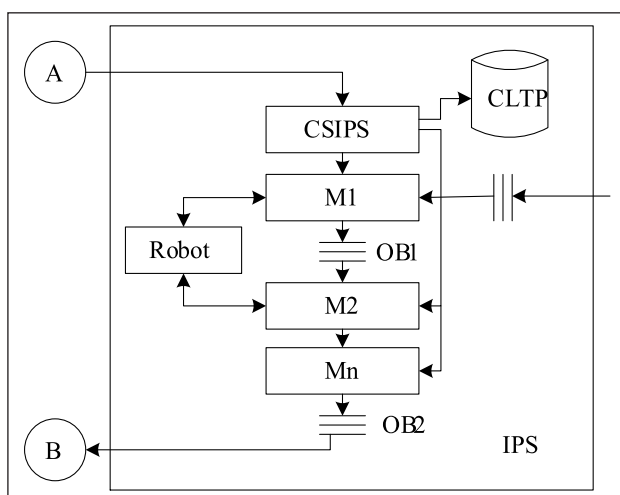

**Figure 2** The proposed Integrated Production System (IPS)

- The question is whether the activities mentioned at b) are to be carried out by logistics or robotics specialists or industrial engineers.

## CONCLUSION

The difference between continuous production and discrete production in Industry 4.0 conditions is that the discrete production process consists of NC machines, robots, manipulators, buffers, etc. In continuous-discrete production, there are big devices, aggregates, storage tanks that form program-automatically controlled production lines, where the movement among individual operations is realized on the basis of gravity, pressure and energy potential difference, which is largely realized without human intervention even in automated (non-automatic) production processes. The production process is also understood as one production unit in automated production, which has a central program for automatic control based on sensing and monitoring of quantities and their control to achieve the required parameters of the product. The direction is realized in the form of dispatch control combined with automatic control of tests (i.e. production of cement in the cement plant, production of iron in a blast furnace, production of electricity in a nuclear power plant, etc.). Management has the character of a predominantly control function as a decision-maker.

The methodology and algorithm presented in Chapter 3 describes the new proposed approach for conditions of Industry 4.0 and its comparison with the current production logistics system. Of course, this cannot be understood as a universal solution. There are differences between the control of discrete and continuous processes as described in Chapter 4.

## Acknowledgement

The submitted work is a part of the project VEGA 1/0317/19, "Research and development of new smart solutions based on principles of the Industry 4.0, logistics, 3D modelling and simulation for production streamline in the mining and building industry.", funded by the Scientific Grant Agency of the Ministry of Education, science, research and sport of the Slovak Republic and the Slovak Academy of Sciences."

## REFERENCES

- D. Malindžák, Production logistics I. Košice, Štroffek Publishing, 1998, pp. 78-90.
- D. Malindžák, P. Kačmáry, G. Ostasz, A. Gazda, B. Z. Madura, M. Lorek, Design of logistic systems (Theory and Application). New York, Open Science Publishers, 2015, p. 300.
- M. Hajduk, M. Sukop, J. Semjon, R. Jánoš, J. Varga, M. Vagaš, Principles of formation of flexible manufacturing systems. Technical Gazette 25 (2018)3, 649-654.
- P. Macurová, I. Ludvik and M. Žwaková, The Driving Factors, Risks and Barriers of the Industry 4.0 Concept. Journal of Applied Economic Science (2007)12, 203-211.

- [5] E. Hofmann, M. Rüscher, Industry 4.0 and the current status as well as future prospects on logistics. *Computer in Industry* (2017)89, 23-24.
- [6] M. Straka, M. Malindžaková, A. Rosová, P. Trebuna, The simulation model of the material flow of municipal waste recovery. *Przemysl chemiczny* (2016)95, 773-777.
- [7] J. Janeková, J. Fabianová, A. Rosová, Environmental and Economic Aspects in Decision Making of the Investment Project 'Wind Park'. *Polish Journal of Management Studies* 13 (2016)1, 90-100.
- [8] L. D. Xu, E. L. Xu and L. Li, Industry 4.0: state of the art and future trends. *International Journal of Production Research* (2018)56, 2941-2962.
- [9] Á. Bányai, B. Illés, E. Glistau, N.I.C. Machado, P. Tamás, F. Manzoor, T. Bányai, Smart cyber-physical manufacturing: Extended and real-time optimization of logistics resources in matrix production, *Applied Sciences-basel* 9 (2019)7, 1287.
- [10] P. Bindzár, S. Sang, E. Gasanov, R. Aliyarov, Sustainable Development as a Global Trend and an Economic Priority for the Nation. In *E3S Web of Conferences* (2018), 1-6.
- [11] A. Rosová, Indices system design of distribution logistics, transport logistics and materials flow as parts of controlling in enterprise's logistics, *Acta Montanistica Slovaca* (2010)15, 67-72.
- [12] S. Saniuk, A. Saniuk, Challenges of industry 4.0 for production enterprises functioning within cyber industry networks. *Management Systems in Production Engineering* (2018)26, 212-216.
- [13] D. Malindžák, J. Šaderová, D. Vítko, M. Malindžaková, A. Gazda, The methodology and model for in-process inventories calculation in the conditions of metallurgy production. *Metalurgija* 54(2015)1, 227-230.
- Note:** The responsible translator for English language is Ladislav Pivka, Institut of Computer technics, Technical University of Košice, Slovakia