



Article

# Power Quality Measurement and Active Harmonic Power in 25 kV 50 Hz AC Railway Systems

Yljon Seferi <sup>1,\*</sup> , Steven M. Blair <sup>1,2</sup> , Christian Mester <sup>3</sup>  and Brian G. Stewart <sup>1</sup> 

<sup>1</sup> Department of Electronic and Electrical Engineering, University of Strathclyde, Glasgow G1 1XQ, UK; steven.m.blair@strath.ac.uk (S.M.B.); brian.stewart.100@strath.ac.uk (B.G.S.)

<sup>2</sup> Synaptec Ltd., Glasgow G1 1XW, UK; steven.blair@synaptec

<sup>3</sup> Federal Institute of Metrology METAS, Lindenweg 50, 3003 Bern-Wabern, Switzerland; christian.mester@metas.ch

\* Correspondence: yljon.seferi@strath.ac.uk

Received: 8 October 2020; Accepted: 27 October 2020; Published: 30 October 2020



**Abstract:** Railway electrical networks rated at 25 kV 50 Hz are characterised by significant levels of voltage and current harmonics. These frequency components are also time varying in nature due to the movement of trains and changing operational modes. Processing techniques used to evaluate harmonic results, although standardised, are not explicitly designed for railway applications, and the smoothing effect that the standard aggregation algorithms have on the measured results is significant. This paper analyses the application accuracy of standardised power quality (PQ) measurement algorithms, when used to measure and evaluate harmonics in railway electrical networks. A shorter aggregation time interval is proposed for railway power quality measurement instruments, which offers more accurate estimated results and improved tracking of time varying phenomena. Harmonic active power present in railway electrical networks is also evaluated in order to quantify the impact it has on the energy accumulated by electrical energy meters installed on-board trains. Analysis performed on 12 train journeys shows significant levels of non-fundamental active power developed for short periods of time. As an energy meter will inadvertently absorb the financial cost of non-fundamental energy produced by other trains or other external power flows, results are provided to support recommendations for future standards to measure only fundamental frequency energy within train energy measurement meters.

**Keywords:** railway electrical networks; traction converter; power quality analysis; active power; harmonic power; electric energy meters

## 1. Introduction

Railway electrical networks are characterised by significant distortion levels that are very high compared to other public electrical networks. AC locomotives, depending on the converter system used, may draw or produce large harmonic currents and can be affected by the quality of the power supply voltage. As a phenomenon, harmonics are described and the possible sources of disturbances are presented in detail in the literature [1–6]. References [1,7] focused on harmonic patterns produced by different types of converters employed in locomotives.

Voltage and current harmonic behaviour in AC traction systems has previously been studied by a broad research community. In this context, much effort has been made in designing appropriate and representative 25 kV 50 Hz electric rail network models. Through simulations, the impact of harmonics generated by locomotives having either AC electric traction motors [8] or DC traction motors [9] on the 110 kV 50 Hz upstream power supply electric grid has been studied. It has been also possible to identify characteristic harmonics emission levels produced by traction units and quantify their

influence on the excitation of network components natural resonance frequencies [5,10,11]. The latter considerations have been particularly important for network planning, decision making or proposing relevant harmonic and resonance mitigation techniques on actual running rail networks [12–17].

Measurement based power quality (PQ) and harmonic analysis can be performed either by analysing recorded voltage and current quantities in railway electrical networks, as reported in [18–20] concerning different countries, with different supplied voltages and frequencies to identify relevant disturbances, or by using off-the-shelf PQ analysers [21–23] to then propose relevant mitigation techniques. Therefore, its common practice to evaluate the harmonic emission levels and other relevant PQ parameters in a real rail operating network by using standardised [24,25] PQ analysers and following general acceptable [26,27] recommendations. These instruments employ measurement methods described in international standards IEC 61000-4-30 [24] and IEC 61000-4-7 [25] with respect to 50/60 Hz public AC power supply systems.

However, these standards are not specially designed for railway applications, and presently, there is no standard or measurement procedure that defines acceptable metrics for electrified railway networks [28,29]. An initiative to define PQ metrics was presented in [28,29], where some PQ indices and their corresponding standardised measurement algorithms were discussed, slightly modified, and proposed to be applicable to AC 16.7 Hz and DC traction power supply systems.

In such a context and considering both the relevance of harmonics and the need for a more accurate assessment of their emission levels, this paper evaluates the accuracy of standard voltage and current harmonic measurement algorithms [24,25] when applied to 25 kV 50 Hz rail electrical signals. Correct and accurate application of harmonic measurement algorithms in railway power networks is needed to reflect the time varying nature of frequency components [18]. Therefore, different time-aggregation intervals for PQ instrumentals are investigated as part of this paper. This will allow a better characterisation of significant levels of distortion and consequently a better understanding of the negative effects such as overheating, losses, vibration, the malfunction of electronic devices, etc., caused by the presence of harmonics on the rail network components. Furthermore, having more accurate PQ measurement instruments will contribute to a more robust and accurate statistical definition of the electromagnetic compatibility (EMC) levels for individual harmonics for railway electrical networks [28]. Effective measurements will also enable improved compliance verification of equipment ratings with standardized local regulations.

In addition to real power, this paper also evaluates harmonic active power in 25 kV 50 Hz rail electrical networks and analyses harmonic power flow by considering the sign of active power harmonics [30,31]. Due to large levels of distortion produced by locomotives, harmonic active power cannot be considered negligible in AC traction systems, and it is shown for several real journeys that it reaches significant levels for short periods of time. The corresponding levels of harmonic energy will be measured by energy meters [32], specified by the European Commission [33] to be installed in all trains for the purpose of establishing a fairer trade of electrical energy based on real energy consumption. This harmonic energy will therefore be reflected in the electricity usage of the train as an added financial cost inadvertently absorbed due to the presence of non-fundamental energy generated by other trains or external disturbances. This absorption, and hence the financial cost, depends both on the train running mode and on the network topology. The cost can significantly increase when a train passes from one part of the railway network to another part with a more distorted electrical supply as in [19] or older locomotives having DC traction motors that operate under the same supplied section [9,21–23]. To prevent this power cost issue and establish a fairer trade of electrical energy, analysis performed on 12 train journey recordings is undertaken to demonstrate the need for improved energy meter strategies that reflect better the relevant cost of correct power usage. Preliminary results of this work were presented in [34] and presented internally at 16ENG04 MyRailS meetings.

The paper is structured as follows: Section 2 presents an overview of the possible harmonic sources in 25 kV 50 Hz AC railway networks. Section 3 presents examples of the harmonic analysis of recorded train voltage and current signals and evaluates the accuracy of standard PQ measurement

algorithms. Section 4 describes the method used to evaluate the non-fundamental active power, while Section 5 presents the results of non-fundamental active power present in rail electrical networks. Section 6 provides conclusions and recommendations from the paper.

## 2. Harmonic Sources in 25 kV 50 Hz Railway Systems

The distortion of voltage and current waveforms in AC traction systems is caused by many factors. The traction substation (TS) supplying power to the catenary wire is not a pure sinusoidal source itself. A certain quality of power is conveyed through the network feeding the TS and is affected by the number of non-linear devices present on the network and the unbalanced conditions of the power supply system [2,18,35]. Typical frequency spectra of the voltage signal measured under no load conditions in a TS indicate that the 2nd, 3rd, 5th, 7th, 11th and 13th harmonics are the main background harmonic voltages of the network [4].

Locomotive traction converters are the main generators of harmonic currents flowing into the overhead contact line (OCL). Generally, the characteristic harmonics produced by these converters are known. Phase controlled converters using thyristors produce low order harmonics comprising the 3rd, 5th, 7th, 11th and 13th order harmonics, whereas modern four-quadrant-converters (4QC) based on pulse-width modulation (PWM) control techniques generate high frequency components around the switching frequency and multiples of the switching frequency as characteristic harmonics [2,5,7]. A common 4QC power electronic system that is widely used in 25 kV 50 Hz locomotives is shown in Figure 1.

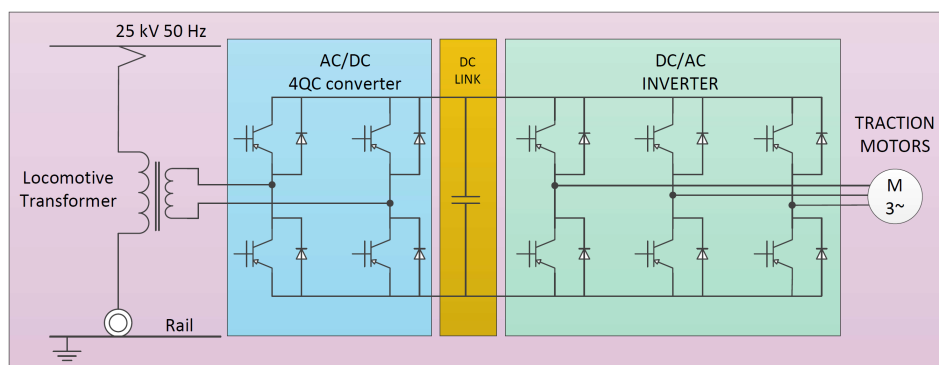

**Figure 1.** Four-quadrant-converters (4QC) power electronic system used in AC locomotives in 25 kV 50 Hz rail network.

In addition, auxiliary converters together with electronic devices with non-linear characteristics inside the train are all sources of distortion for incoming AC signals.

The inrush current of a locomotive transformer is another periodic harmonic source generator in AC traction systems. During a journey, a train has to pass several times under phase separation sections of the power supply network [36]. During this time, the feeding of the main transformer inside the locomotive is interrupted for several seconds [37]. After the train leaves one of the sections supplied by one phase and enters the next section supplied by the next phase, the main transformer of the locomotive is re-energized. The magnetizing current of the transformer produces low order current harmonic frequencies up to 300 Hz [2,26,38].

Less periodic, but frequent components are the harmonics and interharmonics injected by time varying phenomena. Arc events due to pantograph bounces [39], and other oscillatory transients, produce low to medium frequency components [5,35]. Series or parallel resonances also easily change the amplitude of the fundamental and harmonic components, influencing the overall frequency spectrum of the signals seen at the pantograph [5,18,36]. Other phenomenon such as rapid changes of the magnitude and phase angle of fundamental and harmonic components, related to the variability of the traction load and regenerative braking processes, are all temporary sources, which also give rise to

harmonics and interharmonics [24]. For convenience, Table 1 summarizes the harmonics encountered in 25 kV 50 Hz rail networks together with their sources. Figures 2 and 3 present typical voltage and current harmonic spectrums, representing a portion of the coasting phase of a running locomotive.

**Table 1.** Harmonic sources in 25 kV 50 Hz railway systems.

| Harmonics                    | Harmonic Sources   |
|------------------------------|--|
| Background harmonics         | Unbalance condition and the presence of non-linear devices in the power supply system    |
| Characteristic harmonics     | Locomotive traction converters of type phase controlled or 4QC                           |
| Characteristic harmonics     | Auxiliary converters of the train  |
| Current harmonics            | Electronic devices with non-linear characteristics                                       |
| Current harmonics            | Power supply interruption and re-energization of locomotive transformer                  |
| Harmonics and interharmonics | Initiated by time varying phenomena such as arcs, transients and resonances              |
| Harmonics and interharmonics | Due to rapid changes of magnitude and phase angle of fundamental and harmonic components |

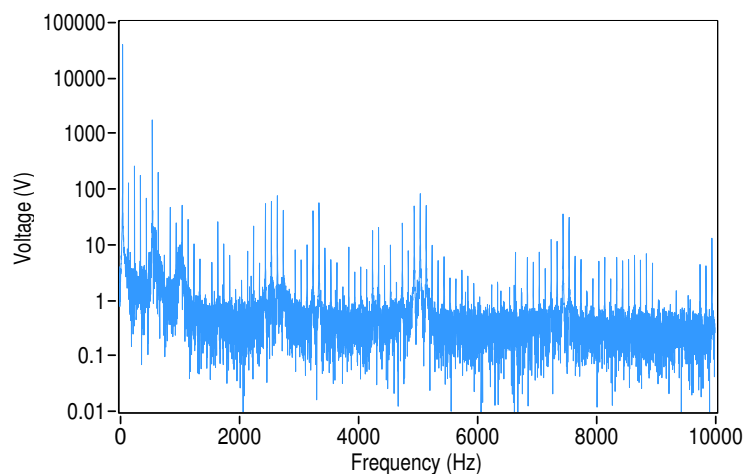

**Figure 2.** A typical voltage spectrum in 25 kV 50 Hz rail networks.

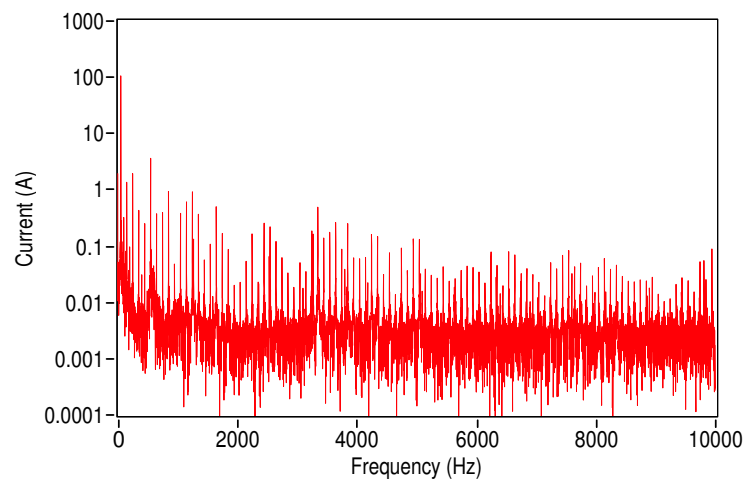

**Figure 3.** A typical current spectrum in 25 kV 50 Hz rail networks.

It can be observed that the low order voltage and current harmonics, below 1 kHz, have higher magnitudes than harmonics in the rest of the spectrum. This is probably due to the influence of characteristic harmonics generated by the locomotive traction converter. To understand present power measurement methods, the following section focuses on accuracy issues of the standard PQ algorithms applied to analyse voltage and current harmonics on a railway network.

### 3. Voltage and Current Harmonic Analysis

The measurement techniques used for the evaluation of harmonic voltages, harmonic currents and the calculation of the total harmonic distortion (THD) index are defined in IEC 61000-4-30 [24] and IEC 61000-4-7 [25]. For railway applications, a standard procedure for measuring and evaluating harmonic results has not yet been defined; however, the methods described in [24,25] are presently used for harmonic analysis of these grids. In this context, reference [18] discussed the advantage of using the short time Fourier transform (STFT) instead of the typical discrete Fourier transform (DFT) for harmonic analysis in rail applications. Despite improvements in the measurement techniques, an important factor to be considered is the accuracy of the processed output results. PQ measuring instruments that are in conformity with Class A measurement [24] are required to aggregate (using the square root of the arithmetic mean of the squared input values) the measurement results without time gaps in two time intervals of 150 cycles for 50 Hz signals and 10 min, before making them available to the end user. The smoothing effect that the aggregation process can have on the measurement results may be negligible when such PQ instruments are intended to analyse electrical networks with low and slowly varying levels of distortion. In contrast, rail electrical networks are characterised by signals having time dependent frequency components with large values of harmonics distortion. Hence, aggregation intervals shorter than 150 cycles are needed to better evaluate the presence of time varying harmonics in such networks.

This section presents the harmonic analysis of voltage and current signals measured at the pantograph level in various European 25 kV 50 Hz railway networks. It then presents a comparison of harmonic and THD measurement results obtained by the standard aggregation measurement method and when applying a shorter aggregate time interval. The signals used for this analysis are part of the waveform database of the 16ENG04 MyRailS project [40,41]. The project aims can be summarized as follows: to develop new calibration facilities and accurate measurement systems, together with new PQ and energy measurement algorithms and simulation models; to assess the metrological reliability of on-board energy measurement systems under highly distorted replicated signals; to provide new metrics for PQ phenomena characterising both AC and DC rail networks; to assess through real measurements and numerical simulations respectively the energy wasted in breaking rheostats and the impact the reversible substation has on the overall energy saved through transferring it back to the AC power supply system; and to support and validate, through accurate measurements, new economical driving algorithms.

The analysed signals are recorded by a data acquisition system (DAQ) sampling at 50 kS/s installed on-board the trains. The spectral analysis of the sampled voltage and current waveforms is performed by the STFT algorithm. A Hanning window function is chosen to reduce the spectral leakage and improve the accuracy of the fundamental and harmonics components. The size of the time window was chosen to be 10 cycles in order to maintain a frequency resolution of 5 Hz as recommended by IEC 61000-4-7 [25]. The signal and window function are multiplied and then processed by the algorithm in order to produce the Fourier coefficients. Next, the time window slides on the signal by a half cycle (10 ms) to better track the dynamics of the time varying components. Harmonics represented by their RMS values, for voltage and current waveforms, up to the 50th harmonic order are calculated as required by IEC 61000-4-30 [24].

Figure 4 presents an example of the fundamental voltage and current magnitudes for one selected train journey of approximately 9.5 min.

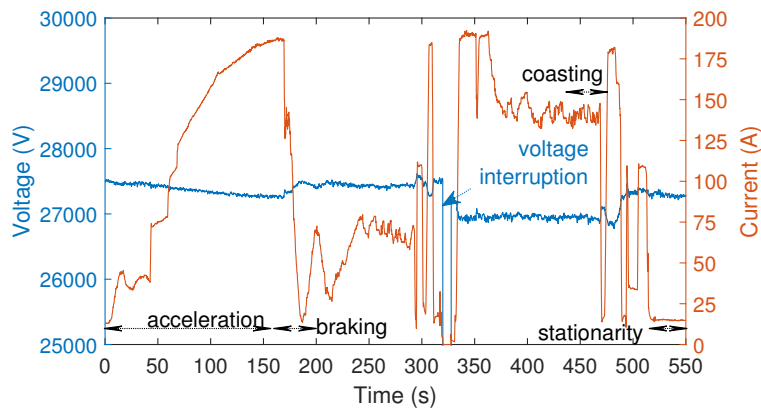

Figure 4. Voltage and current fundamental components.

The selected example exhibits the largest harmonic values from the available train journey recordings. Significant time variation of the load gives rise to the voltage variations seen in Figure 4. A voltage interruption occurred between 325 and 332 s, which was caused by the phase separation section of the power supply network. Different current absorption patterns are presented in Figure 4, caused by different operating modes of the train. These include: smooth acceleration; coasting; several braking stages; and stationary.

Figures 5 and 6 present respectively the results of harmonic voltage and current variability for the most significant harmonics during the considered train journey.

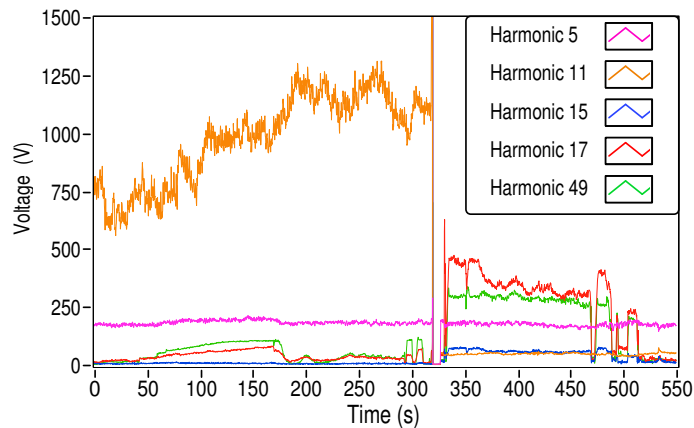

Figure 5. Voltage harmonics during the train journey.

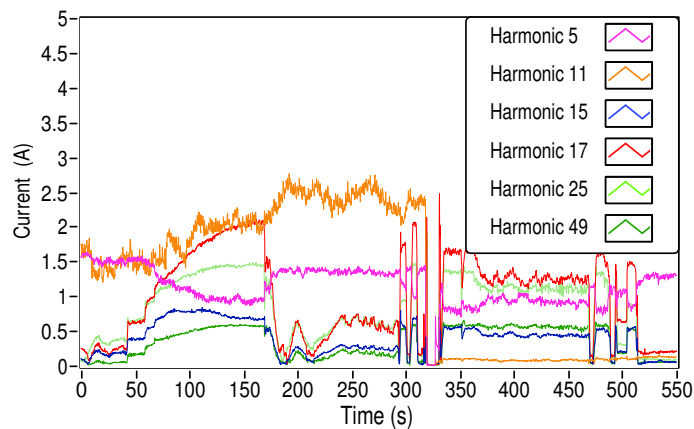

Figure 6. Current harmonics during the train journey.

The most dominant harmonics contained in the voltage and current signals are the odd harmonics, whereas even harmonics are negligible. In order to understand whether the current harmonics are generated by the locomotive traction converter or generated by the network, a correlation analysis for each of the current harmonics with respect to the fundamental current harmonic at 50 Hz is performed by using Pearson's correlation coefficient. The correlation analysis presented in Table 2 shows a strong positive correlation of the 15th, 17th, 25th and 49th current harmonics, graphically presented in Figure 6, with the fundamental current harmonic.

**Table 2.** Correlation analysis of fundamental harmonics.

| Harmonic Order | Pearson's Correlation Coefficient |
|----------------|-----------------------------------|
| 5              | −0.51                             |
| 15             | 0.91                              |
| 17             | 0.94                              |
| 21             | 0.88                              |
| 23             | 0.86                              |
| 25             | 0.98                              |
| 27             | 0.88                              |
| 31             | 0.71                              |
| 33             | 0.98                              |
| 35             | 0.78                              |
| 37             | 0.79                              |
| 43             | 0.76                              |
| 45             | 0.86                              |
| 49             | 0.95                              |

Less significant, but strongly correlated with the train operation conditions are also the rest of the current harmonics as denoted by their correlation coefficients in Table 2. It is clear that almost all these current harmonics are generated by the locomotive converter and are typical characteristic harmonics generated by a phase controlled converter. An exception (by looking at Figure 6) is the fifth harmonic current, which has a weakly negative correlation with the fundamental current. The fifth harmonic current, which does not follow the pattern of the fundamental current, may result from a possible combination of the harmonic current generated by the locomotive converter with the background harmonic of the same order. This is confirmed by a voltage correlation analysis, where a strong positive correlation of 0.86 exists between the fifth harmonic voltage and the voltage fundamental.

To appreciate the distortion levels, Figure 7 presents the voltage and current THD calculated from the RMS values of the harmonics.

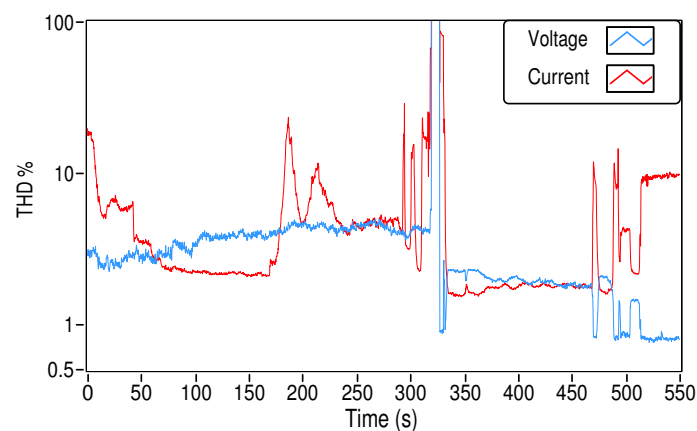

**Figure 7.** THD of voltage and current.

The large values of current distortion are expected in AC rail networks where a locomotive behaves as multiple current sources at several harmonic frequencies, giving rise to voltage distortions

at the pantograph level that propagate throughout the electric rail network. To prevent this unwanted phenomenon, several techniques are proposed to attenuate harmonic currents generated by traction converters or background harmonics coming from the three-phase upstream power grid by the research community. These include traditional passive filtering through a combination of single-tuned filters and high pass filters [5,14,21,22] or active filtering [2], an active compensation techniques using a static VAR compensator to improve power factor and regulate the voltage level, combined with filtering to attenuate the resulting harmonics [12,42], hybrid solutions consisting of a combination of active and passive filters [16,17] or from the locomotive traction drive itself by using one LCL filter to attenuate characteristic harmonics generated by the PWM locomotive converter [15]. Despite the proposed solutions, limiting the harmonic distortions in 25 kV 50 Hz rail networks still remains a challenge. This is because on one hand, there is still a variety of mixed old and new locomotives operating in the same network having different characteristic harmonics to deal with and, on the other hand, the simulated models employed for harmonic analyse and mitigation techniques do not fully represent all the possible loading and operating modes of the locomotives of a real rail network.

In Figure 7, the large spikes in voltage and current THD observed between 325 s and 332 s are associated with the voltage interruption caused by the phase separation section of the power supply network. As can be seen, the voltage and current signals are characterized by time varying frequency components. The STFT method used can continuously track the harmonic disturbances in shorter intervals and allows harmonic variability and THD changes to be established as a function of short time intervals.

In Figure 8, a comparison of the measurement results for the 17th harmonic current (being the most significant harmonic generated by the locomotive during the train journey) obtained by using different time intervals to aggregate the results is presented.

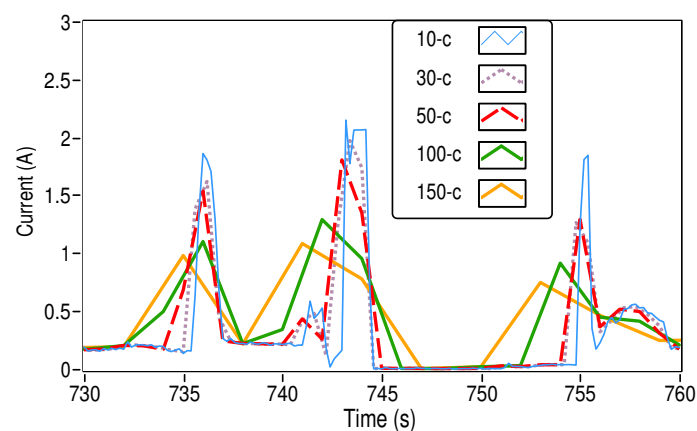
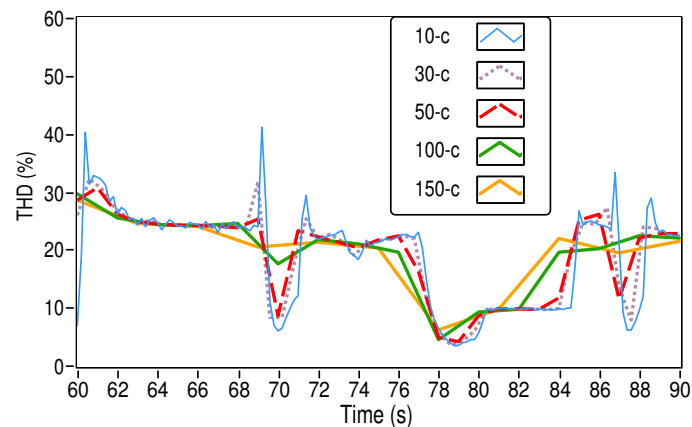

**Figure 8.** The 17th harmonic current measured over 10 cycles and aggregated over 30, 50, 100 and 150 cycles.

Figures 9 and 10 present examples of the THD results calculated over the same aggregation time intervals.

Significant differences of more than 10% can be observed from the figures between the measurement results obtained by aggregation over 10 cycles and over the standard 150 cycles. It is clear that harmonic and THD measurement results, aggregated in 150 cycle time intervals [24], cannot track the true dynamics of the signals. This is due to the significant smoothing effect that the standard aggregation algorithm [24] has on the measurement results, causing all time varying components to be underestimated. In addition, a long aggregation time interval introduces an integration slope error (slopes become more linear; compare for example the yellow curve with the red or blue curve in Figure 8) that results in different calculated areas under the curves, indicating that the results are not comparable.





**Figure 9.** Current THD results measured over 10 cycles and aggregated over 30, 50, 100 and 150 cycles representing 60 to 90 s time intervals.

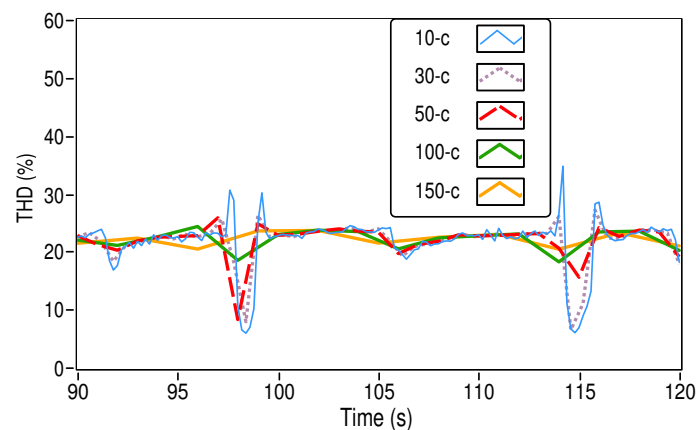

**Figure 10.** Current THD results measured over 10 cycles and aggregated over 30, 50, 100 and 150 cycles representing 90 s to 120 s time interval.

Instead, a shorter aggregation time interval equal to 50 cycles for 50 Hz signals offers improved accuracy of the estimated values and closer tracking of time varying components. Clearly, this is more useful for adoption in PQ instruments designed explicitly for railway applications. Shorter aggregation time intervals also have the ability to establish a closer correlation of the event or the phenomena with its time of occurrence. Therefore, a 50 cycle aggregation time interval can reduce the time localisation uncertainty by a factor of three compared to a 150 cycle aggregation. It is of course possible to reduce the aggregation time intervals even further, for example to 30 cycles instead of 150 cycles. The accuracy of the estimated results will be further improved with the expense of increasing the amount of data produced and reported by a factor of five.

#### 4. Non-Fundamental Active Power Calculation

Calculation of non-fundamental active power is based on the definitions of IEEE Std. 1459 [43]. The active power developed by a sinusoidal source is calculated by Equation (1) considering the average value of the instantaneous power during a selected measurement time interval:

$$P = \frac{1}{kT} \int_0^{kT} p(t) dt = \frac{1}{kT} \int_0^{kT} v(t) i(t) dt \quad (1)$$

where  $p(t)$  is the instantaneous power;  $v(t)$  and  $i(t)$  are the instantaneous values of pantograph voltage and current, respectively;  $T$  is the fundamental time period (20 ms) corresponding to a 50 Hz fundamental frequency; and  $k$  is a positive integer number.

In non-sinusoidal conditions, the instantaneous voltage and the corresponding instantaneous current are expressed by Equations (2) and (3), where  $v_0$  and  $i_0$  are the direct voltage and the direct current terms,  $v_1$  and  $i_1$  are the fundamental voltage and current terms, etc.

$$v(t) = v_0 + v_1(t) + v_2(t) + v_3(t) + \dots \quad (2)$$

$$i(t) = i_0 + i_1(t) + i_2(t) + i_3(t) + \dots \quad (3)$$

By considering that a non-sinusoidal source may contain also interharmonics, subsynchronous harmonics and direct voltage and current, Equations (2) and (3) can be written as:

$$v(t) = v_1(t) + v_H(t) \quad (4)$$

$$i(t) = i_1(t) + i_H(t) \quad (5)$$

where the terms  $v_H(t)$  and  $i_H(t)$  include all the frequency components contained in the signal except the fundamental. Applying Equations (4) and (5) to (1), the expression for active power takes the form:

$$P = \frac{1}{kT} \int_0^{kT} [v_0 + v_1(t) \dots] [i_0 + i_1(t) + \dots] dt = \sum_{s=0}^{\infty} \frac{1}{kT} \int_0^{kT} v_s i_s dt = \sum_{s=0}^{\infty} P_s \quad (6)$$

where  $v_s$  and  $i_s$  comprise direct terms, fundamental terms and harmonic terms respectively for the voltage and current signals; and  $P_s$  is the active power developed in the circuit by the  $s$ th harmonic order. Considering the presence of frequency components other than harmonics, Equation (6) can be rewritten as:

$$P = P_1 + P_H \quad (7)$$

where  $P$  is the active power;  $P_1$  is the fundamental active power; and  $P_H$  is the non-fundamental active power. The fundamental active power is calculated by Equation (8):

$$P_1 = V_1 I_1 \cos \theta_1 \quad (8)$$

where  $V_1$  and  $I_1$  are fundamental components of voltage and current extracted by applying the DFT algorithm to the voltage and current signals, and  $\theta_1$  is the angle difference between fundamental voltages and currents. The remaining non-fundamental active power  $P_H$ , which contains frequency components with and without an integer relationship to the fundamental, as well as any DC component, is calculated by Equation (9):

$$P_H = V_0 I_0 + \sum_{h=2}^{\infty} V_h I_h \cos \theta_h = P - P_1 \quad (9)$$

Equations (1), (8) and (9) are used to extract active power, fundamental active power and non-fundamental active power considering voltage and current signals.

## 5. Harmonic Power Flow Analysis

Non-fundamental active power impacting the measured electrical energy together with absorbed and regenerated active power for all the considered train journeys is evaluated in this section. The active power flowing bidirectionally during acceleration, coasting and regenerative braking is measured by energy meters to calculate consumed and regenerated electrical energy. Simultaneously, the harmonic active power, flowing from the train to the utility or exchanged between other trains

and vice versa, is also being measured. EN 50463-2 [32] considers the technical and metrological requirements for new energy meters to be installed in every train as required by the European Commission [33], for measurement and billing purposes. However, EN 50463-2 [32] does not prescribe a separation of the fundamental active energy from the active energy. As a consequence, energy meters will count both fundamental and non-fundamental energy generated by other trains, which, as will be demonstrated below, is not negligible. This leads to an erroneous evaluation of energy usage.

This section evaluates the non-fundamental active power to quantify the impact on the energy accumulated by any installed energy meters, with a view to recommend appropriate measurement procedures for a fairer measurement and costing of electrical energy.

As examples, Figures 11 and 12 represent the results of fundamental active power for two different train journeys (Journeys 1 and 12).

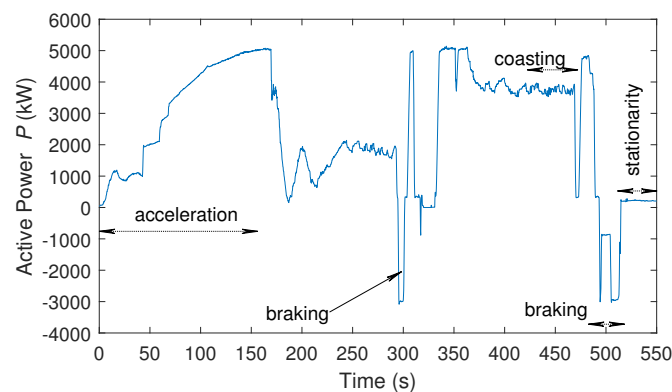

**Figure 11.** Fundamental active power consumed and regenerated: Journey 1.

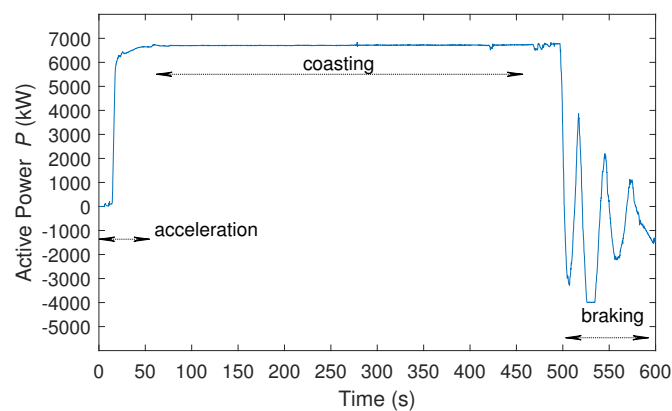

**Figure 12.** Fundamental active power consumed and regenerated: Journey 12.

Instantaneous voltages and currents are determined using the DFT algorithm over a 10 cycle measurement time interval as required by IEC 61000-4-30 [24]. Both figures indicate likely running modes of the train, that is acceleration, coasting characterized by constant active power and braking characterized by negative power where the fundamental active power is delivered back to the network.

Harmonic power flow variability for the two journeys is presented in Figures 13 and 14.

This analysis has considered harmonic power up to the 50th harmonic order. The figures represent the active power flow of the most dominant harmonics carrying considerable active power. As indicated by these figures, active harmonic power cannot be considered negligible in these traction systems and can flow in the same direction with the fundamental active power; for example, as can be seen in the case of the 11th harmonic (see Figure 13) or flow in the opposite direction as shown by the 17th harmonic of Journey 1 and Journey 12. In other words, this indicates harmonic power flows outside the train toward the network (distorting the network, given by a negative value), or from the network to the train (distorting the train, given by a positive value).

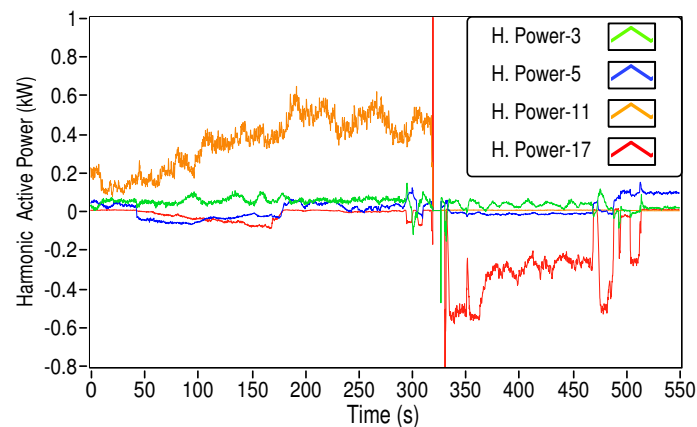

Figure 13. Harmonic power, 3rd, 5th, 11th and 17th, of Journey 1.

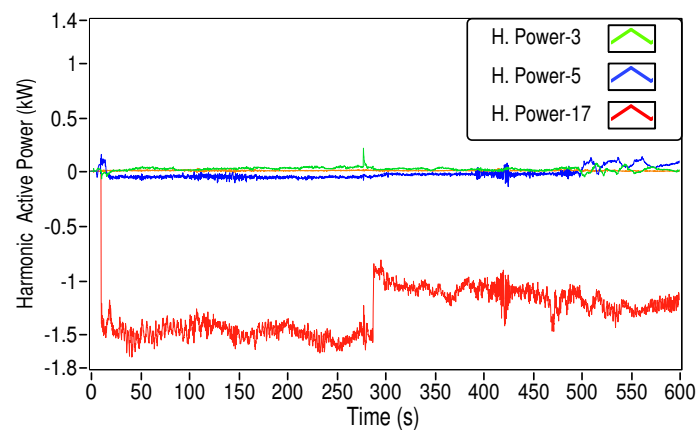

Figure 14. Harmonic power, 3rd, 5th, and 17th, of Journey 12.

Less dominant harmonics carrying negligible active power in Journey 1, are the 9th, 23rd, 25th, 35th, 45th and 49th harmonics. All these harmonic powers have a negative value, and consequently, the locomotive distorts the network at these corresponding frequencies. Harmonic powers of the order 5th, 7th, 13th and 19th fluctuate between positive and negative values during the journey. At these frequencies, the network and the locomotive continuously and interchangeably distort each other. It may be noted that the third harmonic power has a positive value, meaning that the network distorts the locomotive at this harmonic. Regarding Journey 12, harmonics carrying negligible active power are the 19th, 21th, 23rd, 25th, 27th and 49th harmonics, which have a negative value. Harmonic power of the orders 5th, 13th and 15th fluctuates between positive and negative values during the journey, whilst the third and the 33rd harmonic powers have a positive value.

Non-fundamental active power  $P_H$ , positive active power  $P_+$  (consumed power) and negative active power  $P_-$  (regenerated power) are calculated as average values of the instantaneous power over 10 cycle intervals and reported for the 12 recorded train journeys in Table 3.

The level of non-fundamental active power  $P_H$  reflects the active power carried by all frequency components of the signal, excluding the fundamental, for the reported period of time (journey time), which allows the total non-fundamental energy over the monitoring period to be calculated. As energy meters according to EN 50463-2:2017 [32] will not separate the non-fundamental energy from the total active energy, they will continuously count it as generated by other trains. This issue becomes even more significant when trains of different owners share the same network and pass from one part of the rail network to another with a more distorted electrical supply, as for example when they cross relevant borders and countries [19].

**Table 3.** Positive active power, negative active power and non-fundamental active power.

| Journey | Journey Duration (min) | $P_+$ (kW) | $P_-$ (kW) | $P_H$ (kW) |
|---------|------------------------|------------|------------|------------|
| 1       | 9.5                    | 2475.3     | −98.4      | 0.13       |
| 2       | 18.5                   | 1098.8     | −906.9     | −0.29      |
| 3       | 10.0                   | 2430.4     | −338.2     | 0.14       |
| 4       | 4.2                    | 4135.8     | 0.0        | 0.16       |
| 5       | 13.3                   | 3833.2     | −4.7       | 0.19       |
| 6       | 13.0                   | 5009.5     | −430.9     | 1.14       |
| 7       | 9.7                    | 2145.5     | −207.5     | −0.02      |
| 8       | 4.1                    | 3127.5     | 0.0        | 0.43       |
| 9       | 18.0                   | 2921.2     | −103.9     | 0.25       |
| 10      | 24.9                   | 4019.8     | −15.1      | 0.25       |
| 11      | 9.6                    | 467.4      | 0.0        | 0.05       |
| 12      | 10.0                   | 5299.7     | −222.1     | −1.25      |

This energy may constantly accumulate and cannot be considered negligible. Indeed, for several journeys, it may reach significant levels for short periods of time. The financial cost of both inward and outward energy flows of non-fundamental energy produced by other trains and other power sources will therefore be included within the power meter calculations on the train.

This evidence aims to support the recommendation that future rail network energy meters should consider measuring only the energy carried by the fundamental component as a fairer trade of electrical energy, based on the real consumption of the train.

This recommendation is not intended either to contradict any network operator policy that predicts extra charges for customers who distort the network above a certain level or exclude the cost of harmonic energy from being financially account. In such a context, if harmonic energy has to be considered, it should not be attributed to measurement registers of the meters devoted to determine the active energy.

The analysis of harmonic power flow is based on the evaluation of the sign of active harmonic powers [30,31], and besides the economical interest, it also has scientific importance. Trains running under the same supply section may be of different models and ages and employ different converter technologies on board or similar models under different operating modes at the same moment in time. For example, one train could be accelerating while another is coasting or braking. In this scenario, each locomotive will generate a set of characteristic harmonic currents of different magnitudes and at the same time will consume distorted currents generated by other locomotives. By evaluating the active power carried by each harmonic frequency, it is possible to indicate specific frequencies where the locomotive distorts the network and frequencies where the locomotive is affected by the network distortions, mainly produced by other locomotives. By periodically performing this evaluation, it is possible to quantify the significance of harmonic power and establish trends that indicate whether the network distortion influences are larger than those produced by the locomotive or vice versa. This will allow a better understanding of electrical and thermal stresses caused by harmonic presence on network components. In such a context, network operators can rely on these data and use them for a better evaluation of the life time of the network components, hence to schedule maintenance services more accurately. An example of this trend is presented in Figure 15, where the 3rd, 5th, 11th and 13th harmonic active power components are presented for each journey.

As can be seen, the third harmonic active power for all 12 journeys has a positive value indicating that the locomotive is affected by the network distortions. A more fluctuating behaviour is experienced for the fifth harmonic active power where the network has a larger influence on the locomotive in Journeys 1, 2, 3, 9 and 11, whereas the locomotive has a larger influence on the network in Journeys 4, 5, 6, 7, 8, 10 and 12. At the 11th and 13th harmonic frequencies, the network mainly distorts the locomotive except in Journeys 1 and 12 (for the 11th harmonic active power) and in Journeys 2, 3, 4

and 11 (for both harmonic frequencies) where no obvious influence of the network on the locomotive and vice versa is observed.

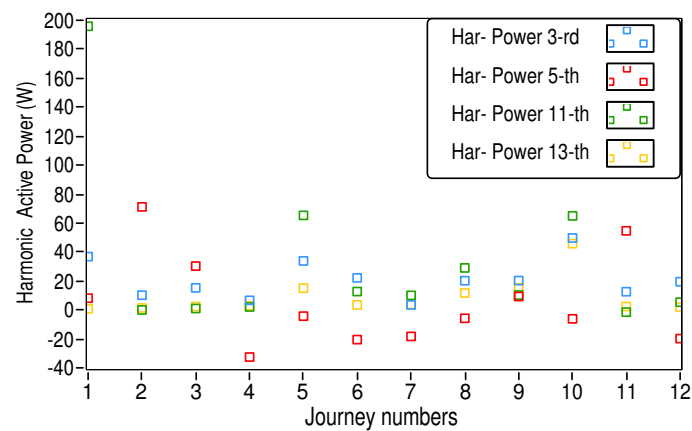

**Figure 15.** Trend of network influences. Harmonic active power, 3rd, 5th, 11th and 13th harmonics.

The magnitude of each active power harmonic changes during a journey (see Figures 10 and 11) and between journeys as it depends on the number of trains running under the same supply section; their position with respect to the each other; characteristic harmonics magnitudes and their respective phases; impedance variability of the OCL; and normally the presence and magnitudes of background harmonics. This variability at each active power harmonic indicates a larger network influence on the train when harmonic active power has a positive sign (i.e., harmonic power flowing into the train) or the locomotive has a larger influence on the network when harmonic active power has a negative sign (i.e., harmonic power flowing onto the network).

## 6. Conclusions

This paper evaluates the accuracy and applicability of standardised PQ measurement algorithms for the evaluation of harmonics in 25 kV 50 Hz rail electrical networks. It is demonstrated that a reduction in the number of cycles over which PQ measurements are made offers improved estimation accuracy of harmonic quantities and subsequently improved tracking of time varying frequency components. As a consequence, a shorter aggregation time interval, equal to 50 cycles for 50 Hz signals, is proposed for future PQ measurement rail instruments.

Based on the power analysis performed on 12 train journey recordings, evidence of non-negligible harmonic energy is provided to support the recommendation that future rail network energy meters should consider measuring only the energy carried by the fundamental component since there is significant variability in the harmonic power flow in and out of the trains. In doing so, trains will not absorb the financial cost of non-fundamental energy produced by other trains on the system, which will ensure a fairer trade of electrical energy based on the real energy consumption. Indeed, energy measurements based on evaluating harmonic energies and the sign of individual energy harmonic flows will enable a more accurate evaluation of total energy per harmonic to be accrued as appropriate.

It is also demonstrated that by evaluating harmonic active power, it is possible to identify specific harmonic frequencies at which a locomotive distorts the network, as well as harmonic frequencies where the locomotive is distorted by the network. Through trending the active harmonic power, it is therefore possible to measure and quantify the variability of the network distortion influences on both the network and on an individual locomotive, thus also permitting an understanding and appreciation of the potential electrical and thermal stresses of harmonics on rail system network components.

**Author Contributions:** Y.S. undertook the literature review and main writing of the paper; Y.S. and B.G.S. developed the PQ algorithms, analysed the signals and processed the results; C.M. and S.M.B. reviewed, commented and edited the whole document including the figures; B.G.S. edited the manuscript and guided the research work. All authors read and agreed to the published version of the manuscript.

**Funding:** The University of Strathclyde and METAS received funding under 16ENG04 MyRailS project, which has received funding from the EMPIR programme co-financed by the Participating States and from the European Union's Horizon 2020 research and innovation programme. This work also received funding from the European Union's Horizon 2020 research and innovation programme MEAN4SG under Marie Skłodowska-Curie Grant Agreement 676042.

**Acknowledgments:** The authors would like to thank the partners of the MyRailS project for making available the data for the analysis presented in this paper.

**Conflicts of Interest:** The authors declare no conflict of interest.

## References

- Brenna, M.; Foadelli, F.; Zaninelli, D. *Electrical Railway Transportation Systems*; John Wiley & Sons: Hoboken, NJ, USA, 2018.
- Bayliss, C.R.; Bayliss, C.; Hardy, B. *Transmission and Distribution Electrical Engineering*; Elsevier: Amsterdam, The Netherlands, 2012.
- Arrillaga, J.; Smith, B.C.; Watson, N.R.; Wood, A.R. *Power System Harmonic Analysis*; John Wiley & Sons: Hoboken, NJ, USA, 1997.
- Gao, S.; Li, X.; Ma, X.; Hu, H.; He, Z.; Yang, J. Measurement-based compartmental modeling of harmonic sources in traction power-supply system. *IEEE Trans. Power Deliv.* **2016**, *32*, 900–909.
- Hu, H.; Shao, Y.; Tang, L.; Ma, J.; He, Z.; Gao, S. Overview of harmonic and resonance in railway electrification systems. *IEEE Trans. Ind. Appl.* **2018**, *54*, 5227–5245.
- CIGRE Working Group 36-05. Harmonics, characteristic parameters, methods of study, estimates of existing values in the network. *Electra* **1981**, *77*, 35–54.
- Mohan, N.; Undeland, T.M.; Robbins, W.P. *Power Electronics: Converters, Applications, and Design*; John Wiley & Sons: Hoboken, NJ, USA, 2003.
- Milešević, B.; Uglešić, I.; Filipović-Grčić, B. Power quality analysis in electric traction system with three-phase induction motors. *Electr. Power Syst. Res.* **2016**, *138*, 172–179.
- Župan, A.; Teklić, A.T.; Filipović-Grčić, B. Modeling of 25 kV electric railway system for power quality studies. In Proceedings of the Eurocon 2013, Zagreb, Croatia, 1–4 July 2013; pp. 844–849.
- Brenna, M.; Foadelli, F.; Zaninelli, D. Electromagnetic Model of High Speed Railway Lines for Power Quality Studies. *IEEE Trans. Power Syst.* **2010**, *25*, 1301–1308, doi:10.1109/TPWRS.2010.2042979.
- Stackler, C.; Morel, F.; Ladoux, P.; Dworakowski, P. Modelling of a 25 kV–50 Hz Railway Infrastructure for Harmonic Analysis. *Eur. J. Electr. Eng.* **2020**, *22*, 87–96, doi:10.18280/ejee.220201.
- Hu, L.; Morrison, R.E.; Young, D.J. Reduction Of Harmonic Distortion And Improvement Of Voltage Form Factor In Compensated Railway Systems by Means of a Single Arm Filter. In Proceedings of the ICHPS V International Conference on Harmonics in Power Systems, Atlanta, GA, USA, 22–25 September 1992; pp. 83–88.
- Morrison, R.E. Power quality issues on AC traction systems. In Proceedings of the Ninth International Conference on Harmonics and Quality of Power (Cat. No. 00EX441), Orlando, FL, USA, 1–4 October 2000; Volume 2, pp. 709–714.
- Kusko, A.; Peeran, S.M. Tuned Filters for Traction Rectifier Sets. *IEEE Trans. Ind. Appl.* **1985**, *IA-21*, 1571–1579.
- Song, W.; Jiao, S.; Li, Y.W.; Wang, J.; Huang, J. High-Frequency Harmonic Resonance Suppression in High-Speed Railway Through Single-Phase Traction Converter With LCL Filter. *IEEE Trans. Transp. Electrif.* **2016**, *2*, 347–356.
- Tan, P.C.; Loh, P.C.; Holmes, D.G. A robust multilevel hybrid compensation system for 25-kV electrified railway applications. *IEEE Trans. Power Electron.* **2004**, *19*, 1043–1052.
- He, Z.; Zheng, Z.; Hu, H. Power quality in high-speed railway systems. *Int. J. Rail Transp.* **2016**, *4*, 71–97.
- Mariscotti, A. Measuring and analyzing power quality in electric traction systems. *Int. J. Meas. Technol. Instrum. Eng. IJMTIE* **2012**, *2*, 21–42.

19. Mariscotti, A. Results on the power quality of French and Italian  $2 \times 25$  kV 50 Hz railways. In Proceedings of the 2012 IEEE International Instrumentation and Measurement Technology Conference, Graz, Austria, 13–16 May 2012; pp. 1400–1405.
20. Mariscotti, A. Direct measurement of power quality over railway networks with results of a 16.7-Hz network. *IEEE Trans. Instrum. Meas.* **2010**, *60*, 1604–1612.
21. Popescu, M.; Bitoleanu, A.; Dobriceanu, M. Harmonic current reduction in railway systems. *WSEAS Trans. Syst.* **2008**, *7*, 689–698.
22. Vasanthi, V.; Ashok, S. Harmonic issues in Electric Traction system. In Proceedings of the 2011 International Conference on Energy, Automation and Signal, Bhubaneswar, India, 28–30 December 2011; pp. 1–5.
23. Sane, S.; Sharma, S.; Prasad, S.K. Harmonic analysis for AC and DC supply in Traction sub station of Mumbai. In Proceedings of the 2015 IEEE International Conference on Electrical, Computer and Communication Technologies (ICECCT), Coimbatore, India, 5–7 March 2015; pp. 1–5, doi:10.1109/ICECCT.2015.7225985.
24. IEC 61000-4-30:2015. *Electromagnetic Compatibility (EMC)—Part 4-30: Testing and Measurement Techniques—Power Quality Measurement Methods*; International Electrotechnical Commission, Geneva, Switzerland, 2015.
25. IEC 61000-4-7. *Electromagnetic Compatibility (EMC) —Part 4-7: Testing and Measurement Techniques—General Guide on Harmonics and Interharmonics Measurements and Instrumentation, for Power Supply Systems and Equipment Connected Thereto*; International Electrotechnical Commission, Geneva, Switzerland, 2008.
26. *IEEE Recommended Practice for Monitoring Electric Power Quality*; IEEE Std 1159-2019 (Revision of IEEE Std 1159-2009); Institute of Electrical and Electronics Engineers: Piscataway, NJ, USA, 2019; pp. 1–98, doi:10.1109/IEEESTD.2019.8796486.
27. *IEEE Recommended Practice and Requirements for Harmonic Control in Electric Power Systems*; IEEE Std 519-2014 (Revision of IEEE Std 519-1992); Institute of Electrical and Electronics Engineers: Piscataway, NJ, USA, 2014; pp. 1–29, doi:10.1109/IEEESTD.2014.6826459.
28. Femine, A.D.; Gallo, D.; Giordano, D.; Landi, C.; Luiso, M.; Signorino, D. Power Quality Assessment in Railway Traction Supply Systems. *IEEE Trans. Instrum. Meas.* **2020**, *69*, 2355–2366, doi:10.1109/TIM.2020.2967162.
29. Femine, A.D.; Gallo, D.; Landi, C.; Luiso, M. Discussion on DC and AC Power Quality Assessment in Railway Traction Supply Systems. In Proceedings of the 2019 IEEE International Instrumentation and Measurement Technology Conference (I2MTC), Auckland, New Zealand, 20–23 May 2019; pp. 1–6, doi:10.1109/I2MTC.2019.8826869.
30. Swart, P.; Van Wyk, J.D.; Case, M. On techniques for localization of sources producing distortion in three-phase networks. *Eur. Trans. Electr. Power* **1996**, *6*, 391–396.
31. Ferrero, A. Measuring electric power quality: Problems and perspectives. *Measurement* **2008**, *41*, 121–129.
32. CENELEC EN 50463-2:2017. *Railway Applications—Energy Measurement on Board Trains—Part 2: Energy Measuring*; European Committee for Electrotechnical Standardization: Brussels, Belgium, 2017.
33. *Commission Regulation (EU) No 1302/2014 of 18 November 2014 Concerning a Technical Specification for Interoperability Relating to the ‘Rolling Stock—Locomotives and Passenger Rolling Stock’ Subsystem of the Rail System in the European Union*; European Commission: Brussels, Belgium, 2014.
34. Seferi, Y.; Stewart, B.G. *Initial Summary of Analyses of Waveforms of 25 kV 50 Hz Railway System*; University of Strathclyde: Glasgow, UK, 2018.
35. Gazafrudi, S.M.M.; Langerudy, A.T.; Fuchs, E.F.; Al-Haddad, K. Power quality issues in railway electrification: A comprehensive perspective. *IEEE Trans. Ind. Electron.* **2014**, *62*, 3081–3090.
36. CENELEC EN 50388. *Railway Applications—Power Supply and Rolling Stock—Technical Criteria for the Coordination between Power Supply (Substation) and Rolling Stock to Achieve Interoperability*; European Committee for Electrotechnical Standardization: Brussels, Belgium, 2012.
37. Seferi, Y.; Clarkson, P.; Blair, S.M.; Mariscotti, A.; Stewart, B.G. Power quality event analysis in 25 kV 50 Hz AC railway system networks. In Proceedings of the 2019 IEEE 10th International Workshop on Applied Measurements for Power Systems (AMPs), Aachen, Germany, 25–27 September 2019; pp. 1–6.



38. Xie, C.; Tennakoon, S.; Langella, R.; Gallo, D.; Testa, A.; Wixon, A. Harmonic impedance measurement of 25 kV single phase AC supply systems. In Proceedings of the Ninth International Conference on Harmonics and Quality of Power. Proceedings (Cat. No. 00EX441), Orlando, FL, USA, 1–4 October 2000; Volume 1, pp. 214–219.
39. Crotti, G.; Delle Femine, A.; Gallo, D.; Giordano, D.; Landi, C.; Luiso, M.; Mariscotti, A.; Roccatò, P.E. Pantograph-to-OHL arc: Conducted effects in DC railway supply system. *IEEE Trans. Instrum. Meas.* **2019**, *68*, 3861–3870.
40. MyRailS Website. Available online: <https://myrails.it/> (accessed on 29 October 2020).
41. Giordano, D.; Clarkson, P.; Gamacho, F.; van den Brom, H.E.; Donadio, L.; Fernandez-Cardador, A.; Spalvieri, C.; Gallo, D.; Istrate, D.; Laporte, A.D.S.; et al. Accurate measurements of energy, efficiency and power quality in the electric railway system. In Proceedings of the 2018 Conference on Precision Electromagnetic Measurements (CPEM 2018), Paris, France, 8–13 July 2018; pp. 1–2.
42. Zanotto, L.; Piovan, R.; Toigo, V.; Gaio, E.; Bordignon, P.; Consani, T.; Fracchia, M. Filter design for harmonic reduction in high-voltage booster for railway applications. *IEEE Trans. Power Deliv.* **2005**, *20*, 258–263.
43. *IEEE Standard Definitions for the Measurement of Electric Power Quantities Under Sinusoidal, Nonsinusoidal, Balanced, or Unbalanced Conditions—Redline*; IEEE Std 1459-2010 (Revision of IEEE Std 1459-2000)—Redline; Institute of Electrical and Electronics Engineers: Piscataway, NJ, USA, 2010; pp. 1–52, doi:10.1109/IEEESTD.2010.5953405.

**Publisher’s Note:** MDPI stays neutral with regard to jurisdictional claims in published maps and institutional affiliations.



© 2020 by the authors. Licensee MDPI, Basel, Switzerland. This article is an open access article distributed under the terms and conditions of the Creative Commons Attribution (CC BY) license (<http://creativecommons.org/licenses/by/4.0/>).