

**COMPUTER PROGRAM FOR NONLINEAR LEAST SQUARE ANALYSIS OF IMPEDANCE AND ADMITTANCE DATA**

*SP MANOHARAN, S BIRLASEKARAN and C V SURYANARAYANA*

Central Electrochemical Research Institute, Karaikudi-623 006

Emeritus scientist, Anna University, Madras-600 025

**ABSTRACT**

A computer program to estimate the parameter value from the complex impedance data of the equivalent circuit is reported. Non-linear complex least squares fitting is made using a laboratory microcomputer (with real values). Different values are used as the initial guess in the iterative calculation of complex least-square method which fits both real and imaginary components of the actual impedance. The program is tested for simple RC circuits which are generally used to model the electrochemical system by introducing random experimental errors and it is found to converge within a few number of iteration.

**Key Words:** Complex least square method, impedance, computer program

**INTRODUCTION**

To study ionic transport characteristics in solid electrolyte, small signal ac impedance measurements [1-3] are being widely used. Besides, it is also used in understanding the electrochemical processes at the electrode/electrolyte interface [4-5] as well as in the study of the diffusion of species in mixed conductors. The plot of impedance (admittance) data in relation to frequency in the complex plane show distinct features to model them with appropriate equivalent circuits. Evaluation of the circuit elements of these equivalent circuits enable one to relate them to important electrochemical quantities of the system e.g. bulk conductivity of the material, mobilities of the species, double layer capacitance, grain boundary resistance, electrode reaction rate constant etc. which characterize interface and bulk behaviour of the system.

For analysis, geometrical fitting [6] is one of the most widely used classical techniques. This method has several limitations on the accuracy of fitting especially in fitting on two overlapping semicircles or in depressed semicircles. To overcome the above difficulties, computer aided least squares fitting techniques which are able to fit simultaneously the real and imaginary parts of impedance (admittance) data are reported. In this paper, following the nonlinear least squares fitting technique of Marquardt [7], computer programs to be used with a laboratory/home computer to do computer assisted curve fitting of impedance data of different equivalent circuits are presented. The impedance spectrum of depressed as well as overlapped semicircles are also analysed.

**EQUIVALENT CIRCUITS**

To model the electrical response of the electrode/electrolyte/electrode cell over a wide range of frequencies, suitable equivalent circuits are being used to evaluate the physical processes. The main contribution to the cell impedance originates from (a) bulk electrolyte impedance (b) electrode/electrolyte interfacial impedances and (c) measuring lead impedances. The simplified general equivalent circuit to represent the above is shown in Fig. 1

Here  $R_1$  represents the bulk resistance of the electrolyte and  $C_1$  represents the geometrical capacitance of the electrolyte (i.e. for the material having dielectric constant  $\epsilon$  and electrode separation  $L$  the capacitance ( $C_1$ ) is equal to  $\epsilon/4\pi L$  for highly conducting medium  $C_1$  is negligible)

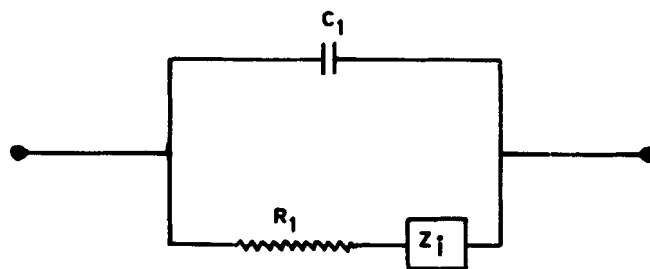

Fig. 1 : General equivalent circuit of an electrochemical cell

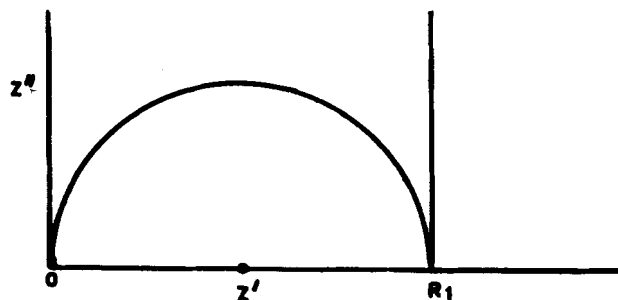
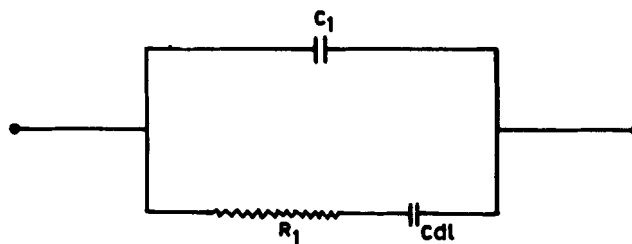

Fig. 2 : Equivalent circuit and resulting complex-plane impedance spectrum for the cell blocking electrode/electrolyte/blocking electrode

$Z_i$  represents the interfacial characteristics of the cell system. For a blocking electrode (e.g. Pt/Ag<sub>4</sub>RbI/Pt) the transfer of charge by conducting ions is blocked. Charge transfer mainly occurs due to the double layer capacitance. In that case  $Z_i = C_{dl}$  and the anticipated impedance diagram would be shown in Fig. 2.

In actual experimental condition, a charge transfer leak current is always present. This condition is accounted by a resistor in parallel with double layer capacitor. The equivalent circuit and its impedance spectrum are represented in Fig. 3.

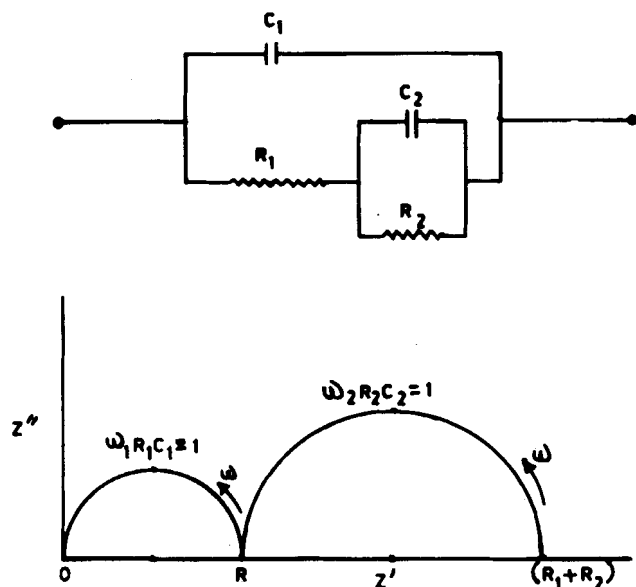

Fig.3 : Equivalent circuit and resulting complex-plane impedance spectrum for the case of charge transfer process represented by a single resistance and a double layer capacitance

If the electrode processes are controlled by the diffusion of ions or molecules towards or from the electrode/electrolyte interfaces, the interfacial impedance is characterized by the Warburg impedance ( $Z_w = (1-j)\sigma\omega^{-1/2}$ ) in which  $\sigma$  contains the diffusion coefficient of the reaction controlling species. In the case of both kinetic and diffusion (mass transfer) controlled reactions, the general impedance plot is shown in Fig.4. In practice, both regions may not be well defined.

If the chemical system is kinetically rather sluggish, it will show a large charge transfer resistance  $R_{ct}$ , and may display only a very limited frequency region. At the other extreme  $R_{ct}$  might be inconsequentially small by comparison to the ionic resistance, and the Warburg impedance over nearly the whole available range of  $\sigma$ . Then the system is kinetically so facile that mass transfer always plays a role, and the semicircular region is not well defined.

**Nonlinear Least-Square Analysis**

Many algorithms for the least squares estimation of nonlinear parameters have conferred about with anyone of the two approaches mentioned below. On the one hand, the model may be expanded as a "Taylor series" and corrections to the several parameters are calculated at each iteration on the assumption of local linearity. On the other hand, various modifications of the method of steepest-descent [8] have been used. Following Marquardt's model on Taylor series expansion, the complex impedance [ $Y_i$ ] is written as a function of angular frequency

$$Y = f(\omega; \theta) \tag{1}$$

where  $\theta = \theta_1, \theta_2, \theta_3, \dots, \theta_k$  are the parameters to be evaluated by minimizing the function

$$\phi = \sum_{i=1}^n |Y_i - Y_i|^2 \tag{2}$$

where  $Y_1, Y_2 \dots Y_n$  are n experimental data points

$$\phi = \sum_{i=1}^n [R_e(Y_i - Y_i)^2 + I_m(Y_i - Y_i)^2] \tag{3}$$

In the non linear least square curve fitting method,  $\phi$  is minimised by setting

$$\frac{\partial \phi}{\partial \theta_j} = 0 \text{ for } j = 1, 2, \dots, k.$$

Equation (3) reduces to the form

$$\frac{\partial \phi}{\partial \theta_j} = 0 = \sum_{i=1}^n [R_e(Y_i - Y_i)^2 R_e\left(\frac{\partial Y_i}{\partial \theta_j}\right) + I_m(Y_i - Y_i) I_m\left(\frac{\partial Y_i}{\partial \theta_j}\right)] \tag{4}$$

If the approximated parameter has a variation  $\Delta \theta$ , the Taylor series expansion of  $f(\omega; \theta)$  would be

$$f(\omega; \theta + \Delta \theta) = f(\omega; \theta) + \sum_{j=1}^k \left(\frac{\partial f}{\partial \theta_j}\right) \Delta \theta_j \tag{5}$$

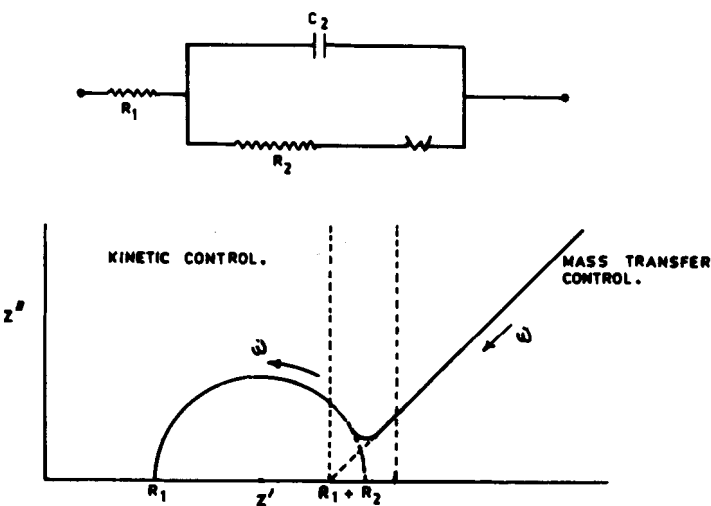

Fig.4 : Equivalent circuit and resulting complex-plane impedance spectrum for the case of both kinetic and diffusion controlled process

substituting (5) in (4) and rearranging in matrix form

$$\Delta\theta = A^{-1}G \quad (6)$$

Where,  $A = \left[ (Z_R)^T \cdot Z_R + (Z_I)^T \cdot Z_I \right]$

$$G = \left[ (Z_R)^T \cdot \Delta Y_R + (Z_I)^T \cdot \Delta Y_I \right]$$

$$[Z_R]_{ij} = R_e \left( \frac{\partial Y_i}{\partial \theta_j} \right)$$

$$[Z_I]_{ij} = I_m \left( \frac{\partial Y_i}{\partial \theta_j} \right)$$

$$[\Delta Y_R]_i = R_e (Y_i - Y_i)$$

$$[\Delta Y_I]_i = I_m (Y_i - Y_i)$$

In this  $\Delta\theta$  is (K x 1) matrix and A is (K x K) square matrix and G is (K x 1) matrix.

This yields K number of simultaneous linear equations which may be solved by a standard numerical method [9] to obtain the best value of the parameters.

**DESCRIPTION OF THE COMPUTER PROGRAM**

Computer program for nonlinear curve fitting is written in BASIC language to be used on any mini/micro computer system. The flow chart of the routine is presented in Fig. 5. Here experimental data are generated for 46 frequencies and two numbers of unknown parameters R and C. The tentatively estimated.

New values of R and C are determined using  $\Delta\theta$ . The difference estimated values are stored in  $Z_{T1}$ . Partial derivatives of real and imaginary in consecutive  $\phi$  values are estimated and if it lies with  $10^{-10}$  the values of  $Z_{T1}$  values with respect to R and C; transpose etc., are determined to R and C are printed out. Separate program following the same principle for estimate "A" matrix and "G" matrix (as given by eqn.6). the other equivalent circuits involving more unknown parameters have been Inverse of "A" matrix is determined and error in parameter value  $\Delta\theta$  is developed and tested for use.

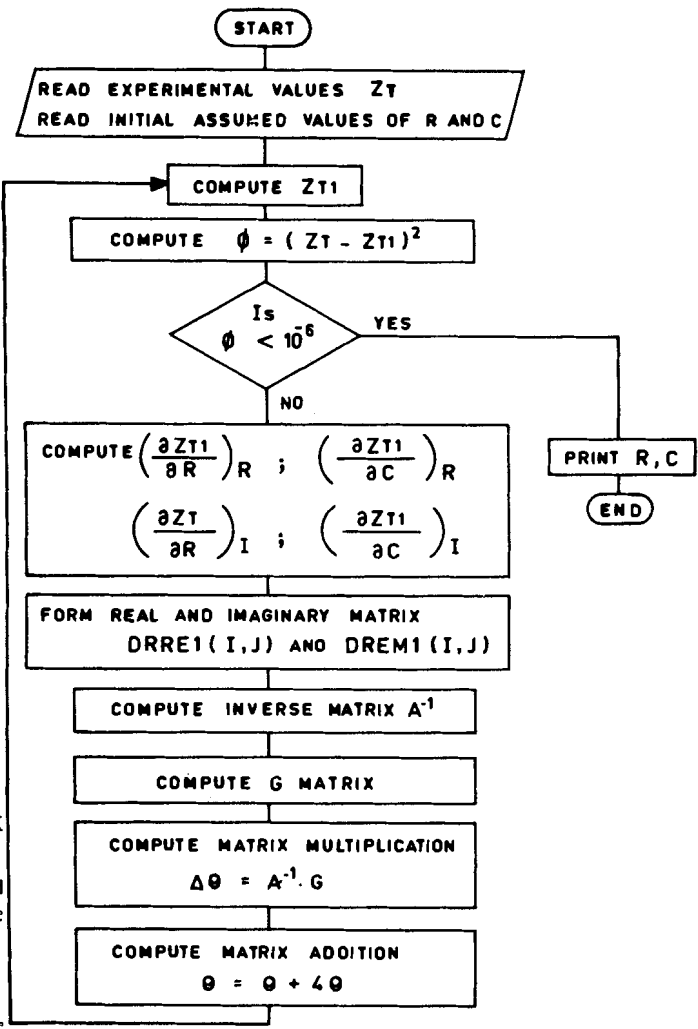

Fig.5 : The flow chart of the computer program

Table I: Nonlinear least squares fitting results for the impedance data of simple R-C network

No.	Initial value	Iteration				Actual value	
		(1)	(2)	(3)	(4)		
I	R (ohm)	500	926.088	999.518	999.999	1000	1000
	C (µf)	0.50	9.816	1.0044	9.9998	1.00	1.0
II	R (ohm)	1500	977.695	997.236	999.907	1000	1000
	C (µf)	0.5	1.286	9.619	9.994	1.00	1.0
III	R (ohm)	500	995.769	996.072	999.927	1000	1000
	C (µf)	0.5	7.613	9.674	9.996	1.00	1.0
IV	R (ohm)	500	995.769	998.588	999.992	1000	1000
	C (µf)	1.5	8.521	9.889	9.998	1.00	1.0

**RESULTS AND DISCUSSION**

Table I presents the complex nonlinear least square (CNLS) analysis results of the equivalent circuit comprising a parallel combination of resistance R and capacitance C as in Fig. 6. In that system impedance data, Z(w)

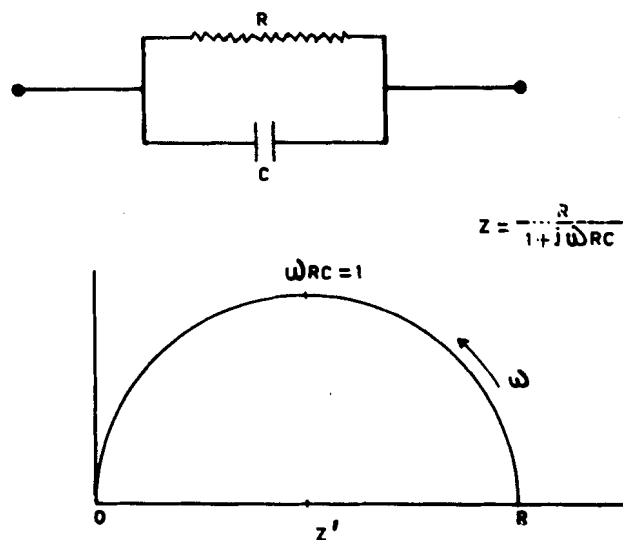

Fig.6 : Complex-plane impedance spectrum for the simple R-C network.

are artificially generated for R = 1 k  $\Omega$  and C = 1  $\mu$ f, over the frequency range of 1 Hz to 1 MHz with 9 data points per decade of frequency equally spaced on a logarithmic scale, using an expression

$$Z(\omega) = \frac{R}{1 + j\omega RC} \quad (7)$$

where  $\omega$  is the angular frequency and  $j = \sqrt{-1}$ . To establish the validity of the computer program for the CNLS analysis, four sets of values of R and C are chosen such that each parameter deviates 50% from its true value. In all these four tests, the initial values of R and C converge very rapidly to the actual value within four iterations.

In the case of the impedance spectrum of depressed semicircle, as shown in Fig.7, CNLS analysis is carried out using the expression [10] similar to Cole formula

$$Z(\omega) = Z_{\infty} + \frac{Z_0 - Z_{\infty}}{1 + (j \frac{\omega}{\omega_0})^{1-\alpha}} \quad (8)$$

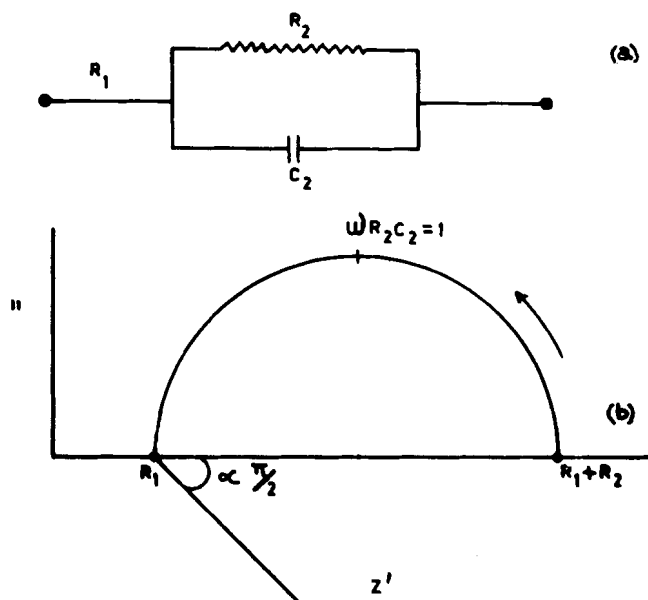

Fig.7 : Complex-plane impedance spectrum of depressed semicircle and proposed equivalent circuit Electro catalysis of hydrogen evolution

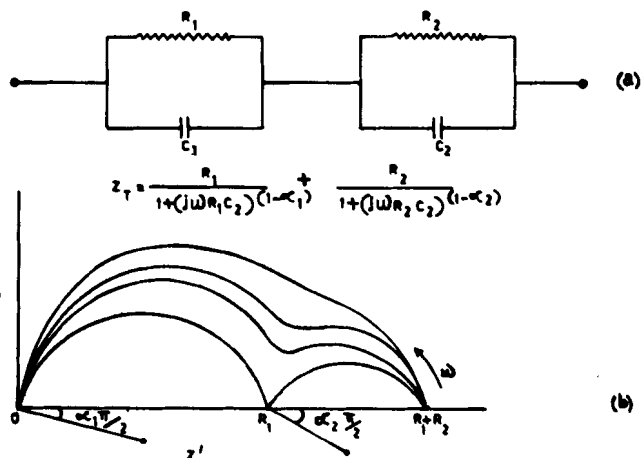

Fig.8 : Complex-plane impedance spectrum of two overlapping semicircles with finite depression angles and the corresponding equivalent circuit

Table II: Nonlinear least squares fitting results for the impedance data corresponding to fig.7

Iteration	R <sub>1</sub> (ohm)	R <sub>2</sub> (ohm)	C <sub>2</sub> ( $\mu$ f)	$\alpha$	$\phi$
Initial value	80.0000	1800.00	2.0000	0.200000	$3.6241 \times 10^6$
1.	47.4464	1137.45	1.5618	0.391648	$4.8006 \times 10^5$
2.	51.0467	1083.29	1.0674	0.177948	$8.2699 \times 10^4$
3.	50.4455	1112.00	1.2326	0.141120	$5.8336 \times 10^3$
4.	50.1365	1111.20	1.2339	0.123679	1.19423
5.	50.1234	1111.23	1.2340	0.123450	$1.0631 \times 10^6$
6.	50.1234	1111.23	1.2340	0.123450	$10^{-10}$
Actual value	50.1234	1111.23	1.2340	0.123450	—

where  $Z_{\infty}$  is the high frequency intercept of the arc with the real axis,  $Z_c$  the low frequency real axis intercept,  $\omega_0$  the relaxation angular frequency,  $\alpha$  the depression parameter. The impedance spectra can be modelled with an equivalent circuit (Fig. 7a) comprising a parallel combination of a resistance  $R_2$  and a frequency dependent capacitance  $C_2(\omega)$  in series with a resistance  $R_1$ . The results of each iteration of CNLS analyse are shown in Table II.

Table III shows the CNLS result of the impedance spectrum of two overlapped semicircles [11,12] as in Fig. 8b.

The corresponding equivalent circuit as shown in Fig. 8a, consists of a series combination of two "Vogid network". Each vogid network has a frequency

Table III: Nonlinear least squares fitting results for the impedance data of a two-arc system

Iteration	$R_1$ (ohm)	$R_2$ (ohm)	$C_1$ ( $\mu$ f)	$C_2$ ( $\mu$ f)	$\alpha_1$	$\alpha_2$	$\beta$
Initial value	150.0000	400.000	1.50000	0.450000	0.444000	0.666000	$2.61638 \times 10^5$
1.	127.3810	200.000	0.750000	0.225000	0.463396	0.426084	$1.73597 \times 10^4$
2.	98.9486	217.246	0.91614	0.264450	0.285196	0.32294	$1.56797 \times 10^3$
3.	99.8161	248.367	1.00250	0.301979	0.228637	0.349398	$3.88225 \times 10$
4.	100.0370	249.961	0.99989	0.300109	0.222140	0.332887	$8.28307 \times 10^{-3}$
5.	99.9999	250.000	1.00000	0.300000	0.222000	0.333000	$2.01989 \times 10^{-7}$
6.	100.0000	250.000	1.00000	0.300000	0.222000	0.333000	$10^{-10}$
Actual value	100.0000	25.000	1.00000	0.300000	0.222000	0.333000	—

dependent capacitance and a resistance. The analytical expression [13] of the equivalent circuit can be written as

$$Z(\omega) = \frac{R_1}{1 + \left(j \frac{\omega}{\omega_{0,1}}\right)^{1-\alpha_1}} + \frac{R_2}{1 + \left(j \frac{\omega}{\omega_{0,2}}\right)^{1-\alpha_2}} \quad (9)$$

where  $\omega_{0,1}$  and  $\omega_{0,2}$  are the relaxation angular frequencies and  $\alpha_1, \alpha_2$  the depression parameters for vogid network 1 and 2 of Fig. 8a.

Examination of Tables I - III reveals that the estimated equivalent circuit parameters are accurate within 0.1% even if the initial values of each parameter are 50% different from their actual values and also the number of iterations for getting best values depends upon the number of variables in the equivalent circuit. However all the parameters converge very rapidly to the theoretical value within a few iterations. Hence the above developed programs can be very effectively used to estimate the parameters of equivalent circuits more critically. By overlaying facility in the computer, a pictorial comparison of experimental and fitted results could be made.

**Acknowledgement:** We would like to acknowledge Dr V K Venkatesan, Head of the Division of Electrochemical Materials Science, Central Elec-

trochemical research Institute, Karaikudi for his keen interest in this work.

One of us (SP Manoheran) is indebted to CECRI for the award of Junior Research Fellowship.

### REFERENCES

1. R D Armstrong, T Dickinson and P M Willis, *J Electroanal Chem Interfacial Electrochem* 53 (1974) 389
2. K Funke, *Progr Solid State Chem* 11 (1976) 345
3. G G Farrington, *J Electrochem Soc*, 121 (1974) 1314
4. H S Isaacs, L J Olmer, E J L Schouler and C Y Yang, *Solid State Ionics* 34 (1981) 503
5. J A Harrison, *Electrochim Acta*, 29 (1984) 703
6. M Kleitz and J H Kennedy, *Fast ion transport in solids*, Eds. P Vashista, J N Mundy, G H Shenoy, North-Holland, Amsterdam (1979) pp. 185
7. Donald W Marquardt, *J Soc Indust Appl Math* 11 (1963) 431
8. I S Berezin and N P Zhidkom, *Computing methods*, Vol. II, Pergaman Press, NY (1965) pp 62
9. D R Hartree, *Numerical analysis* (1958) pp 166
10. D Ravaine and J L Souquet, *Compt Rend Acad Sc.* 277c, (1973) 489
11. K Kitahama and S Kawal, *Solid State Ionics*, 7 (1982) 317
12. J E Bauerle, *J Phys Chem Solids*, 30 (1969) 2657
13. Y T Tsai and D H Whitmore, *Solid State Ionics*, 7 (1982) 129