

**GOVERNMENT OF INDIA, THE PATENT OFFICE
214, ACHARYA JAGADISH BOSE ROAD
CALCUTTA-700017.**

Complete Specification No. 165977 dated 11th August, 1987

Application and Provisional Specification No. 663/Del/86 dated 23rd July, 1986

Acceptance of the complete specification advertised on 17th February, 1990

Index at acceptance— 70 A

International Classification— H 01 m 2/00

**TITLE : IMPROVED ELECTROLYTIC CELL FOR THE PRODUCTION OF CALCIUM
GLUCONATE.**

**APPLICANT : COUNCIL OF SCIENTIFIC AND INDUSTRIAL RESEARCH, Raft Marg,
New Delhi-110001, India, an Indian registered body incorporated
under the Registration of Societies Act. (Act. XII of 1860)**

**INVENTORS : KODETHOOR SHRIVARA UDUP, POOMINATHAN SUBBIAH, KRISHNAMOORTHY
JAYARAMAN, PACHIMUTHU THIRUNAVUKKARASU AND CHELLAMIER SESHADRI.**

The following specification describes the nature of this invention.

PRICE : TWO RUPEES

165977

This is an invention by Kodethoor Shrivara Udupa, Poominathan Subbiah, Krishnamoorthy Jayaraman, Pachaimuthu Thirunavukkarasu and Chellamier Seshadri all from Central Electrochemical Research Institute, Karaikudi - ~~623 006~~, Tamilnadu, India and all Indians citizens and relates to ~~an~~ improved electrolytic cell for the production of calcium gluconate.

Hitherto it has been proposed to oxidize glucose to calcium gluconate by an electrolytic process by using rotating anodes of graphite and stationary graphite cathodes in a Polyvinyl chloride/Polyvinyl chloride lined wooden tank as electrolyser.

Our prior India patent No.51189 describes a process of the type which consists in the electrolytic oxidation of glucose to gluconic acid in the presence of alkali bromide solution as electrolyte and the subsequent neutralisation of gluconic acid with the added calcium carbonate to give calcium gluconate. Indian Patent No.147524 describes an improved cell designs employing rotating anodes. The characteristic features of the above electrolytic cell uses that it ~~rotating~~ ^{stationary} graphite anodes. The anodes used are of cylindrical type and are rotated by suitable electrical motor arrangement. The rotating anodes are surrounded by ~~stationary~~ cathodes of graphite rods/plates arranged concentrically in a polygon around the anode.

This cell has the following drawbacks:

(i) it is not possible to operate the cells at voltages less than 10-12 as it is difficult to bring down the inter electrode distance to less than 12 mm.

(ii) the use of PVC cooling coil inside the electrolytic cell necessitates the use of refrigerant brine for maintaining electrolysis temperature within limits, thereby requiring

investment for refrigeration unit and also adding to the energy requirements for the process.

(iii) the cell requires a rotating assembly for rotating the electrodes and the use of mercury for giving electrical connection to the rotating anodes.

The main objective of the present invention is to obviate these disadvantages by the use of a flow type cell in which graphite electrodes are stacked inside a PVC housing separated from each other by thin PVC/Poly propylene spacers and the electrolyte is circulated through the electrode stack.

The improved cell of the present invention assures a uniform current distribution and enables an efficient circulation of the electrolyte through the electrodes packed inside the PVC housing. It also makes it possible to bring down the inter electrode gap to the minimum (1.5-2.5mm) thereby reducing the operating cell voltage to 3.5 to 4.5V with considerable saving on energy requirements for electrolysis.

The other objectives of the invention are:

(i) the improved design of the electrolytic cell enables the operation of the cells at lower voltages thereby saving on the cooling requirements.

(ii) the cooling of the cell contents can be accomplished by cooling water as compared to refrigerant brine used at present thereby saving on the investment and power requirements due to the use of the refrigeration unit.

The invention is further described in detail with reference to the drawing accompanying this specifications. In the drawings.

165977

Fig. 1 shows the elevation of the cell of the invention.

Figure. 2 shows the top view of the electrolytic cell of the present invention.

The electrodes shown in the Figure 1 are circular graphite plates (ii) packed inside the PVC housing. The PVC housing has provision for circulation of electrolyte. The electrical connection is given to the two end electrodes in the stack. The electrodes in the stack are separated by suitably positioned PVC/Polypropylene spacers (i). The electrolyte is prepared in a tank externally and is circulated through the electrolytic cell by means of a centrifugal pump. At the end of electrolysis, the electrolyte is processed for the recovery of the product.

The electrolyte consists of sodium bromide containing desctrone and calcium carbonate. The number of electrodes may be 8 and the current employed may be of 8-10 Amps. The current density may range from 5 Amp/dm² to 6.25 Amp/dm². The cell voltage may range from 25 to 28V and the voltage per gap may vary from 3.7 to 4.5V. Duration of the electrolysis may be for 12-14 hours.

The following are the main advantages of the invention:

(i) The inter electrode distance and consequently the cell voltage is reduced.

(ii) The power consumption for electrolysis is considerably reduced with consequent energy savings for the process.

(iii) The savings in power consumption also enables the load on heat exchanger to be reduced and the improved cell design facilitates the use of water as the coolant in place of refrigerated brine used at present thereby saving on investment and energy costs due to the use of the Refrigeration Unit.

165977

(iv) The improved cell can be easily assembled and dismantled for maintenance.

(v) The improved cell avoids the use of mercury for giving electrical contact.

(vi) The improved cell enables the continuous operation of the Electrolytic cell.

Dated this 27th day of June 1956.

N. R. Subbaram

(N.R. SUBBARAM)
JOINT ADVISER (PATENTS)
COUNCIL OF SCIENTIFIC AND INDUSTRIAL RESEARCH

5

165977

THE PATENTS ACT, 1970

COMPLETE SPECIFICATION

(Section-10)

TITLE: IMPROVED ELECTROLYTIC CELL FOR THE PRODUCTION OF CALCIUM GLUCONATE.

APPLICANT: COUNCIL OF SCIENTIFIC AND INDUSTRIAL RESEARCH, Rafi Marg, New Delhi-110 001, India, an Indian registered body incorporated under the Registration of Societies Act (Act XXI of 1860).

The following specification particularly describes and ascertains the nature of this invention and the manner in which it is to be performed :—

requirements for the process.

(iii) the cell requires a rotating assembly for rotating the electrodes and the use of mercury for giving electrical connection to the rotating anodes.

The main objective of the present invention is to obviate these disadvantages by the use of a flow type cell in which graphite electrodes are stacked inside a PVC housing separated from each other by thin PVC/Poly propylene spacers and the electrolyte is circulated through the electrode stack.

The improved cell of the present invention assures a uniform current distribution and enables an efficient circulation of the electrolyte through the electrodes packed inside the PVC housing. It also makes it possible to bring down the inter electrode gap to the minimum (1.5-2.5mm) thereby reducing the operating cell voltage to 3.5 to 4.5V with considerable saving on energy requirements for electrolysis.

The other objectives of the invention are:

(i) the improved design of the electrolytic cell enables the operation of the cells at lower voltages thereby saving on the cooling requirements.

(ii) the cooling of the cell contents can be accomplished by cooling water as compared to refrigerant brine used at present thereby saving on the investment and power requirements due to the use of the refrigeration unit.

Accordingly, the present invention provides improved electrolytic cell for use in the production of calcium gluconate comprising

165977

* stack of plurality of stationary graphite disc electrodes characterized in that the stationary graphite disc electrodes are packed inside a PVC housing and separated from each other by thin PVC/Polypropylene spacers with a gap of 1 to 2.5 mm, circulating the electrolyte such as herein described through the electrodes, the two end electrodes having electrical connection.

The invention is further described in detail with reference to the drawing accompanying the provisional specification. In the drawings. Fig. 1 shows the elevation of the cell of the invention.

Figure. 2 shows the top view of the electrolytic cell of the present invention.

The electrodes shown in the Fig. 1 are circular graphite plates (ii) packed inside the PVC housing. The PVC housing has provision for circulation of electrolyte. The electrical connection is given to the two end electrodes in the stack. The electrodes in the stack are separated by suitably positioned PVC/Polypropylene spacers (i). The electrolyte is prepared in a tank externally and is circulated through the Electrolytic cell by means of a centrifugal pump for electrolysis. At the end of electrolysis, the electrolyte is processed for the recovery of the product.

The electrolyte consists of sodium bromide solution containing dextrose and calcium carbonate. The number of electrodes may be 6-12 and the current employed may be of 6-25 Amps. The current density may range from 3 Amp/dm² to 8 Amp/dm². The cell voltage may range from 25 to 60V and the voltage per gap may vary from

165977

3.5 to 5.0V. Duration of the electrolysis may be for 6-18 hours.

The invention is further illustrated by the Examples given below which should not however be construed to limit the scope of the invention.

Example -I

Electrolyte	:	2% Sodium Bromide solution (15 litres) containing 3.0 kg Dextrose monohydrate and 1.2 kg Calcium carbonate.
Area of each electrode	:	1.6 dm ²
Number of electrodes	:	8
Current	:	10 amp
Current density	:	6.25 Amp/dm ²
Cell voltage	:	26 to 28 V
Voltage per gap	:	4 V
Current passed	:	805 A Hr
Calcium gluconate formed	:	2851 g
Current efficiency	:	84.7%
Energy consumption for electrolysis (KWH/Kg of product)	:	1.13 KWH/Kg

165977

Example - II

Electrolyte	:	2% Sodium Bromide solution (15 litres) containing 3.0 kg Dextrose monohydrate and 1.2 kg Calcium carbonate.
Area of each electrode	:	3.0 dm ²
Number of electrodes	:	9
Current	:	15 Amps
Current density	:	5 Amp/dm ²
Cell voltage	:	25-27V
Voltage per gap	:	3.5V
Current passed	:	758 AH
Calcium gluconate formed	:	2516 g
Current efficiency	:	79.4%
Energy consumption for electrolysis (KWH/Kg of	:	1.054 KWH /Kg

Example - III

Electrolyte	:	2% Sodium Bromide solution (15 litres) containing 3.0 kg Dextrose monohydrate and 1.2 kg Calcium carbonate.
Area of each electrode	:	3.0 dm ²
Number of electrodes	:	9
Current	:	20 Amps
Current density	:	6.6 Amp/dm ²
Cell voltage	:	27-29V
Voltage per gap	:	3.6V
Current passed	:	800 AH
Calcium gluconate formed	:	2251 g
Current efficiency	:	67.3%
Energy consumption for electrolysis (KWH/Kg	:	1.244 $\frac{\text{KWH}}{\text{kg}}$

165977

The following are the main advantages of the invention:

(i) The inter electrode distance and consequently the cell voltage is reduced.

(ii) The power consumption for electrolysis is considerably reduced with consequent energy savings for the process.

(iii) The savings in power consumption also enables the load on heat exchanger to be reduced and the improved cell design facilitates the use of water as the coolant in place of refrigerated brine used at present thereby saving on investment and energy costs due to the use of the Refrigeration Unit.

(iv) The improved cell can be easily assembled and dismantled for maintenance.

(v) The improved cell avoids the use of mercury for giving electrical contact.

(vi) The improved cell enables the continuous operation of the Electrolytic cell.

PROVISIONAL specification

NO. 165977

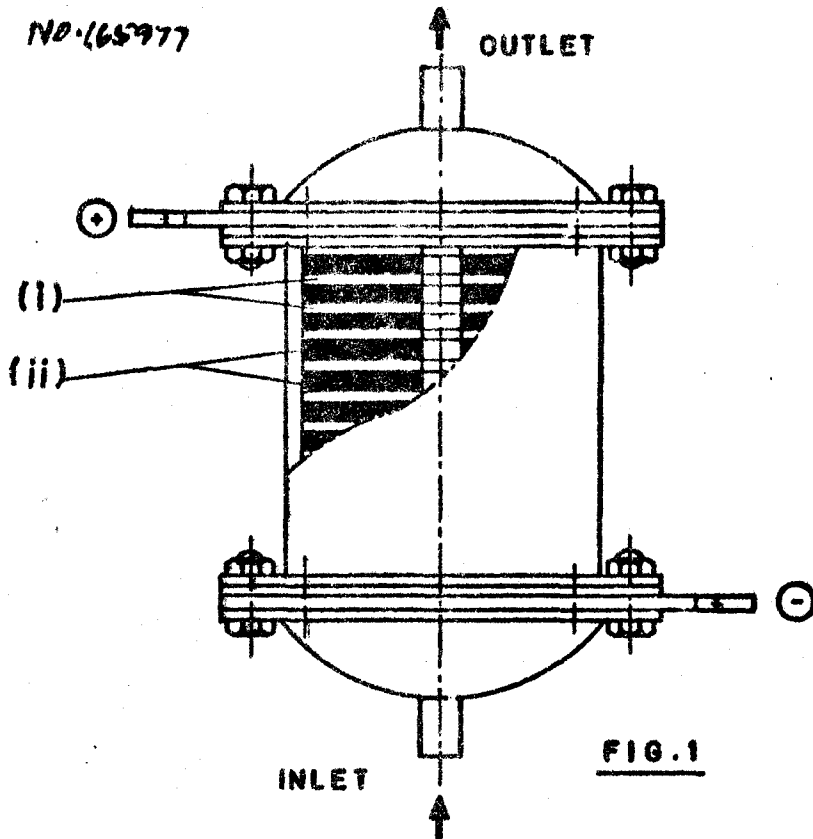

FIG. 1

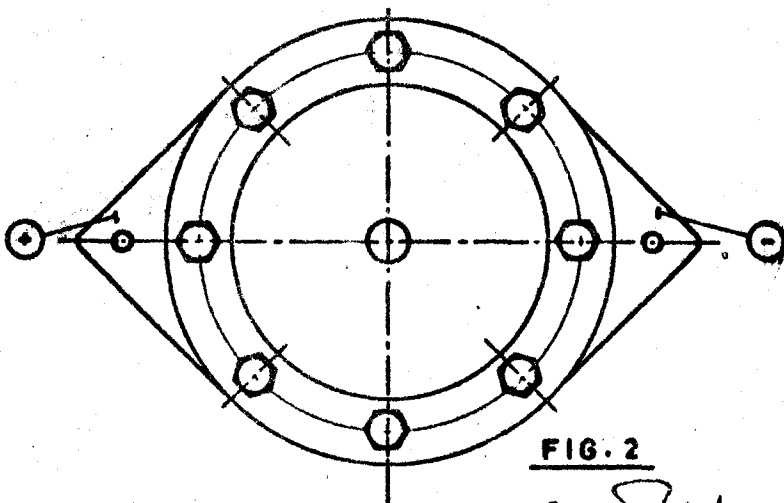

FIG. 2

N. R. Subram

N. R. SUBARAMI,

PATENTS OFFICER,

C S I R .