

Polyimide-coated fibre bragg grating (FBG) sensors for thermal mapping of electric machine windings

Shang, K., Galea, M., Brusica, V., Korposh, S., Zhang, Y.



**University of
Nottingham**
UK | CHINA | MALAYSIA

University of Nottingham Ningbo China, 199 Taikang East Road, Ningbo, 315100, Zhejiang, China.

First published 2020

This work is made available under the terms of the Creative Commons Attribution 4.0 International License:

<http://creativecommons.org/licenses/by/4.0>

The work is licenced to the University of Nottingham Ningbo China under the Global University Publication Licence:

<https://www.nottingham.edu.cn/en/library/documents/research/global-university-publications-licence-2.0.pdf>



**University of
Nottingham**

UK | CHINA | MALAYSIA

Polyimide-coated fibre Bragg grating (FBG) sensors for thermal mapping of electric machine windings

Kun Shang⁺, Michael Galea⁺⁺, Vladimir Brusic⁺, Serhiy Korposh^{*}, Yaping Zhang⁺

^{*}*The University of Nottingham, University Park, Nottingham, UK*

⁺*University of Nottingham Ningbo China, China*

⁺⁺*Key Laboratory of More Electrical Aircraft Technology of Zhejiang Province, China*

e-mail: yaping.zhang@nottingham.edu.cn

ABSTRACT

This paper presents a design concept and a prototype of a polyimide-coated Fibre Bragg Grating (FBG) thermal sensor system based on a fast scan tunable laser source (up to 1kHz sensing frequency). This system was deployed to perform a comprehensive 2-D real-time radial and axial thermal profiling of an electromagnetic coil – the short duty cycle electric machine (EM) windings. The thermal measurements were performed using an equivalent prototype consisting of an FBG interrogator, a multi-FBG string temperature sensor, power resistors (thermal objects), and conventional thermocouples used for measurement comparison. The FBG measurements of copper windings were subsequently carried out using a copper coil with FBG sensors system to map the radial and axial temperature distribution of the coil. The experimental results show that Polyimide-coated FBG sensor can be used for multi-point temperature monitoring of electromagnetic coils with a sensing temperature range of 20-200°C, a spatial resolution of 6cm, and a measurement error of $\pm 2\%$. The obtained thermal maps can be used for the identification of hot spot locations in electromagnetic coil systems.

I. INTRODUCTION

For electrical machines (EM), whether used as motors or generators, a main operational constraint is often the thermal limit [1]. The main bottleneck is maximum permissible hot-spot temperature in the EM windings [2]. Precise knowledge of the physical locations of these hot-spots and their absolute temperature values, can be used by machine designers to reduce the total weight of the EM and improve its lifespan, while providing for the same output power. Alternatively, a better management of operational parameters can prevent overheating and improve the longevity of EMs. For the development and testing of electrical machines, thermal aspects are traditionally monitored by arrays of conventional sensors such as thermocouples (TCs) or resistance thermal detectors (RTDs) [3]. These arrays are complex and costly to implement, and the physical dimensions of these sensors prevent obtaining a complete thermal map of the windings. Additionally, electric sensors are sensitive to electromagnetic interference (EMI), making them unreliable for use in EMs [4]. Therefore, new sensing means that can be embedded within the coils with immunity to EMI are needed for achieving accurate and comprehensive thermal mapping of EM windings.

A feasible alternative to the traditional sensors is the multi-grating FBG sensor system [4],[5]. These dielectric FBG sensors have intrinsic advantages with regards to EM thermal monitoring, including immunity to EMI and small dimensions (125 μ m diameter of optical fibre generally) [6]. Multiplexing techniques developed for FBG sensor systems, such as wavelength division multiplexing (WDM), enable concurrent sensing of a large number of discrete points [7].

An implementation of a Polyimide-coated FBG string system for comprehensive real-time thermal profiling of a short duty cycle electric machine winding, commonly used in EMs, is reported in this paper. Polyimide-coated silica-core FBG sensors allow for both high temperature tolerance (up to 300°C) and stable temperature linear response of spectral shifts at 11 pm/°C for temperatures under 300°C [8]. Our prototype for concurrent temperature measurement at multiple position along electromagnetic coils using multiplexed FBG sensors was developed, tested, and used for a comprehensive thermal mapping of EMs windings.

II. SENSING PRINCIPLE AND THERMAL SENSOR DESIGNS

1. Principles of FBG temperature sensor

The principle of FBG sensing is based on Bragg wavelength shift induced by both applied strain and temperature due to thermo expansion and thermo optic effects. Since our target object, i.e. EM windings, remains physically static in

our thermal experiments, wavelength shift induced by strain variation can be neglected. Consequently, the analytical expressions for reflected Bragg wavelength λ_B and the relationship between Bragg wavelength shift $\Delta\lambda_B$ and temperature variation ΔT can be expressed as:

$$\lambda_B = 2n_{eff}\Lambda$$

$$\frac{\Delta\lambda_B}{\Delta T} = 2n_{eff}\Lambda\left(\alpha_\delta + \frac{1}{n_{eff}}\frac{\Delta n_{eff}}{\Delta T}\right)$$

where n_{eff} is the effective refractive index of optical fibre and Λ is the Bragg grating period. α_δ and ξ_δ are thermal expansion and thermo-optic coefficients, respectively. Using a FBG interrogator from Arcopt Inc [9], we obtained wavelength shift $\Delta\lambda_B$ that can be converted to temperature measurement values of target objects. Polyimide-coated FBG string was chosen for EM temperature monitoring because they feature acceptable temperature range and have good mechanical properties (bend-resistance) [10]. Polyimide-coated FBG has temperature tolerance of up to 300°C for long duration, while pure silica FBG cannot tolerate more than 85°C for long duration sensing. Pure silica FBG with larger bending radius is more fragile compared to the Polyimide-coated FBG. Because FBG sensors need to be coiled tightly with EM windings, polyimide-coated FBG is a preferred option ensuring sensor system's robustness.

2. Equivalent prototype for EM windings hot-spots measurement

In the first experiment, four power resistors were connected in parallel to resemble distributed heat spots, as shown in Figure 1. Four power resistors from Tyco Electronics [11] with electric resistances of 220Ω, 150Ω, 68Ω, 22Ω, respectively, and were arranged in parallel and labelled as resistor 1 to 4 in Figure 1. This arrangement resembles four different heating powers, and therefore result in different surface temperatures. Our design covered the range of 20-200°C for temperature measurement. The power resistors were chosen to mimic practical heating power range of one stator tooth of EM windings with a natural air-cooling system, representing heating power range from 1 to 20 watts. Both the FBG sensors and conventional thermocouples (TCs) were fixed on the surfaces of each power resistor for temperature monitoring and the validation of FBG measurements.

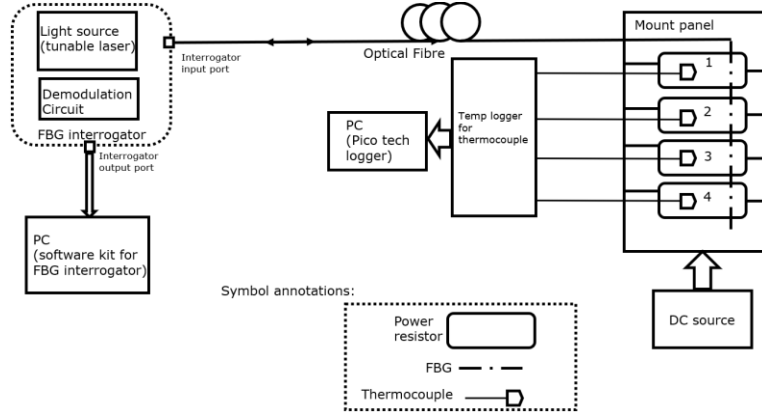

Figure 1 A prototype simulating EM windings for hot-spots temperature measurement

3. Prototype for EM windings embedded with multi-FBG string sensors

On completion of hot-spot experiment with power-resistor panel, a further experiment using copper coils as thermal targets was performed. Such coil resembles the bending conditions on real EM windings. The purpose of this experiment was to assess the feasibility of FBG sensor system for temperature monitoring when attached to EM coils. The configuration of one string of the Polyimide-coated multi-FBG is shown in Figure 2, which contains 8 serially ordered Bragg gratings of FBG sensors. During the second experiment, three such multi-FBG strings, coiled and buried in the middle of an EM copper windings connected to a DC voltage supply as shown in Figure 3, and the WDM technique of FBG Bragg wavelengths were implemented for the thermal monitoring of EM windings. Two thermal maps were generated- the axial thermal map of winding is shown in Figure 3 on the x-z plane while radial thermal map on the y-z plane.

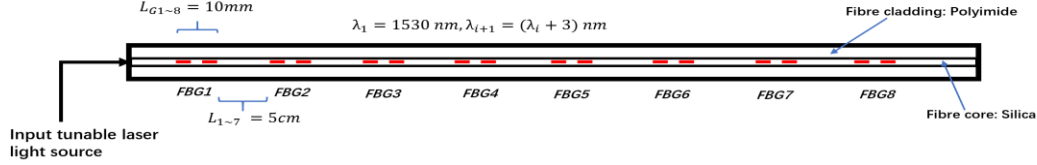

Figure 2 Structure of Polyimide-coated multi-FBG string

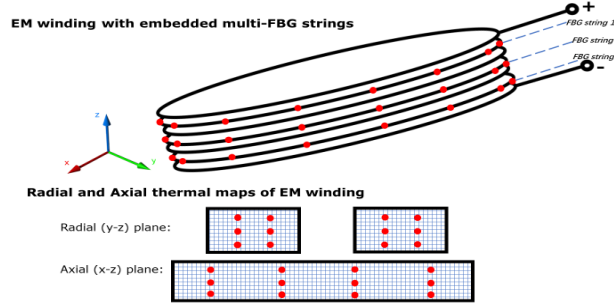

Figure 3 Schematic of three multi-FBG strings embedded together with an EM windings.

III. EXPERIMENTAL RESULTS

1. Thermal maps of the prototype resembling hot-spots

Thermal maps (Figure 4) were plotted by Matlab using temperature data from the FBG interrogator [9]. These data represent static temperature readings of four power resistors when $V_{DC} = 20$ volts was kept on for 20 minutes in a natural air-cooling environment. The experimental setup (Figure 1) was used under constant environmental temperature of 23 °C. The hot-spots thermal map measured by FBG sensors (Figure 4a) was compared with the thermal map measured by thermocouples (Figure 4b). The four temperatures measured by FBG sensors were 3.2% (3.5 ± 1.35) higher than these measured by thermocouples. The thermal maps showed four heat points with temperatures ranging from 35 to 202 °C. This temperature range has completely covered the temperature standard for four insulation classes (A, B, F and H) of electric machines defined by NEMA [12]. These experimental results illustrated that the Polyimide-coated FBG sensors are applicable for EM thermal monitoring with required measurement accuracy.

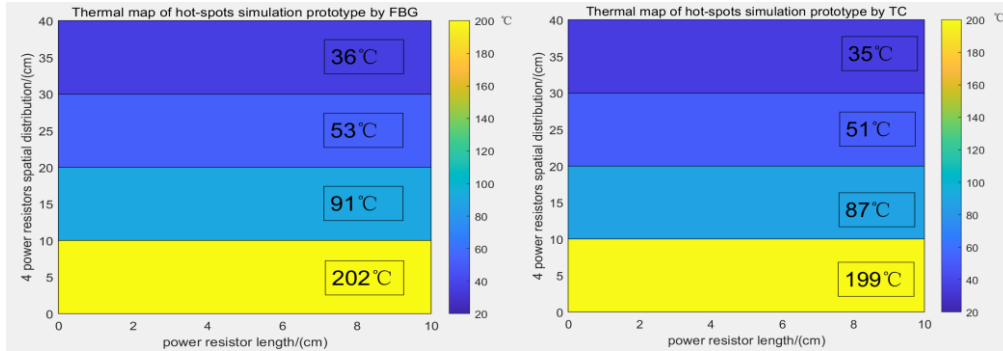

Figure 4 Thermal maps of equivalent hot-spots prototype measured by a) FBG sensors and b) thermocouples

2. Thermal maps of EM windings with multi-FBG string embedded prototype

For thermal mapping, sensors (FBGs) were attached to the real copper coils, as shown in Figure 3. The rest of the experiment setup was kept the same as that in the first experiment (shown in Figure 1). The hot spots shown in Figures 5a) (radial thermal maps) and 5b) (axial thermal maps), were located with a spatial resolution of 6 cm matching the FBG inter-grating distance shown in Figure 2. The locations of these hot-spots indicated that the central and end-winding positions within the EM copper coils are prone to the overheating problems. Spatial resolution can be

improved by either using denser spaced multi-FBG sensors or optimized locations of multi-FBG sensors based on mathematical modeling.

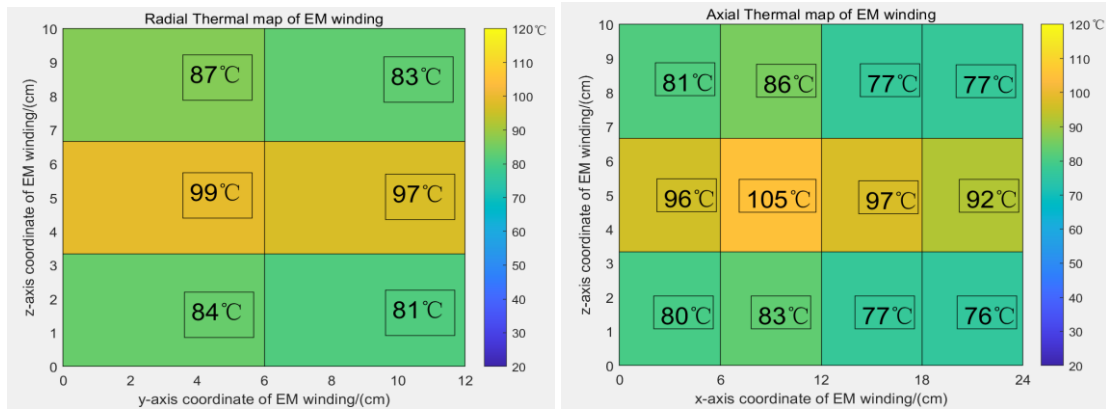

Figure 5 a) Radial thermal map (left panel), and b) axial thermal maps (right panel) of EM windings with multi-FBG string embedded prototype. The experimental parameters are shown in Figure 4.

IV. DISCUSSION AND CONCLUSION

Polyimide-coated multi-grating FBG sensor strings were used to construct a prototype for efficient measurement and real-time construction of 2-D thermal maps of electric machine copper windings, in both radial and axial directions. The FBG thermal sensing system prototype based on tunable laser technology demonstrated advantages for thermal mapping of EM coils: broad temperature detection range (20-200°C), adequate spatial resolution (6 cm) and fast wavelength sweeping frequency (up to 1kHz). Simultaneous thermal maps can be used for real-time monitoring of the distribution and spatial localisation of thermal hot spots within the EM windings. These hot-spot locations are the primary locations for the degradation of winding insulation, a principal cause of the lifespan reduction of the EMs. The design concept of FBG sensor system presented can be used to track thermally vulnerable points, select safe operational regimes, and optimize EM maintenance.

REFERENCE

- [1] V. Madonna, P. Giangrande, L. Lusuardi, A. Cavallini, C. Gerada, and M. Galea, "Thermal Overload and Insulation Aging of Short Duty Cycle, Aerospace Motors," *IEEE Trans. Ind. Electron.*, vol. 67, no. 4, pp. 2618–2629, 2020.
- [2] C. K. T. and L. M. S.-C. Tan, Y.M.Lai, "Review of condition monitoring of rotating electrical machines. Electric Power Applications," *IET Electr. Power Appl. Vol. 1, No. 1*, vol. 67, no. 4, pp. 263–270, 2008.
- [3] T. a Jankowski *et al.*, "Development and Validation of a Thermal Model for Electric Induction Motors," *IEEE Trans. Ind. Electron.*, vol. 57, no. 12, pp. 4043–4054, 2010.
- [4] J. Kumar *et al.*, "Distributed fiber Bragg grating sensor for multipoint temperature monitoring up to 500°C in high-electromagnetic interference environment," *Opt. Eng.*, vol. 55, no. 9, p. 090502, 2016.
- [5] M. Fabian, D. M. Hind, C. Gerada, T. Sun, and K. T. V. Grattan, "Comprehensive Monitoring of Electrical Machine Parameters Using an Integrated Fiber Bragg Grating-Based Sensor System," *J. Light. Technol.*, vol. 36, no. 4, pp. 1046–1051, 2018.
- [6] E. Udd, "The Emergence of Fiber Optic Sensor Technology," in *Fiber Optic Sensors: An Introduction for Engineers and Scientists*, Hoboken, NJ, USA: John Wiley & Sons, Inc., 2011, p. 512.
- [7] K. T. V. Grattan and T. Sun, "Fiber optic sensor technology: An overview," *Sensors Actuators, A Phys.*, vol. 82, no. 1, pp. 40–61, 2000.
- [8] TECHNICA.Ltd, "T20 / Polyimide Coated FBG sensor Datasheet," 2018.
- [9] Arcopt.Inc, "FBG Interrogator Datasheet," 2019.
- [10] FIBRECORE.Ltd, "Pure Silica Core SM Fiber Product specification," 2018.
- [11] T. Electronics, "High Power Resistors-Type SQ series," 2018.
- [12] NEMA, "NEMA MG 1-2016 Motors and Generators," 2018.