

(2.29)

*Joško Parunov, Maro Ćorak**University of Zagreb, Faculty of Mechanical Engineering and Naval Architecture I. Lučića 5,
10000 Zagreb*

USE OF NFEM IN STRUCTURAL DESIGN OF SHIPS WITH ICE NOTATION

Summary

The paper describes practical application of nonlinear finite element method (NFEM) in design of the side shell structure of an oil tanker with ice notation. Different structural configurations of the side shell are investigated in order to find solution that is in the same time the most convenient for the shipyard and acceptable by classification societies. The procedure is immediately applicable as it is prescribed by classification societies in the form of Guidelines Note. It may provide significant cost reduction for the shipyard, and keep safety needs on required level. Result of such calculations is optimum design which justifies usage of direct calculation methods. Computer package Femap with NX Nastran is employed in the study.

Key words: oil tanker, ice navigation, nonlinear finite element method.

PRIMJENA NMKE U PROJEKTIRANJU KONSTRUKCIJE BRODOVA ZA PLOVIDBU U LEDU

Sažetak

Opisan je postupak praktične primjene nelinearne metode konačnih elemenata u projektiranju konstrukcije oplata naftnog tankera namijenjenog plovidbi kroz led. Razne konfiguracije konstrukcije vanjske oplata su istražene s ciljem pronalaženja rješenja koje je istovremeno najpovoljnije za brodogradilište i prihvatljivo za klasifikacijska društva. Procedura je neposredno primjenjiva jer je propisana od klasifikacijskih društava u obliku Guidance Note. Postupak može brodogradilištu omogućiti značajne uštede, dok sigurnosne zahtjeve drži na zahtijevanoj razini. Rezultat takvih proračuna je optimalan projekt, koji u konačnici opravdava korištenje takvih direktnih metoda proračuna. U studiji je korišten kompjuterski program Femap s NX Nastranom.

Ključne riječi: naftni tanker, plovidba kroz led, nelinearna metoda konačnih elemenata

1. Introduction

Floating ice sheets introduce rather large horizontal forces to the side structures of vessels navigating in icy sea. Therefore, ship structures having some of ice notations have to be significantly strengthened. The focus of ice strengthening design is placed on the resistance of side shell structure subjected to lateral loads in the ice belt region. In principle, spacing of longitudinal stiffeners of ships with ice notation is to be 0.45m or less, while brackets have to be provided connecting stiffeners and transverse web frames or bulkheads. The additional steel weight increase of an Aframax oil tanker due to the various ice class notations could range from 2.5% to more than 5% [1]. Welding of brackets and producing panels with rather narrow span of stiffeners additionally contribute to the increasing cost of these vessels. Therefore, there is a great need for optimization of structural reinforcements due to the ice loads.

This fact is recognized by some of classification societies which proposed direct calculation procedure for structural assessment of side shell structure due to the ice impact [2]. Classification societies tolerate small yielding and even plastic deformations on the shell structures when ships navigate in ice. This is possible, since the ice induced loads can be considered as some kind of accidental loads that occurs seldom [3]. Proposed NFEM procedure allows designer to investigate several alternative structural configurations and to select the most convenient one. For example, designer might prefer to increase size of the longitudinal stiffeners with usual stiffener spacing rather than to use smaller longitudinals with rather narrow spacing. Similar considerations can be done for brackets that increase considerably production costs. Overall this procedure helps to solve the problem of imbalance between the strength of framing and shell plating.

This paper describes the practical applicability of the NFEM procedure on the simple example. The aim is to analyse side shell longitudinal stiffener and the side shell plating in the ice belt region and to investigate feasibility of the alternative structural arrangements.

2. Description of the model [2]

The three-dimensional structural model should represent the structural behaviour of the side structures subject to ice loads. In the longitudinal direction, the structural model is to extend a minimum of three webs (three-bay model) with an extra half-frame spacing on the forward and aft ends. In vertical extent the structural model is to extend between the two horizontal stringers that include the ice belt region. Typically, the ice belt is applied in the area of a single longitudinal frame that is halfway between the stringers. The model should contain at least one three-dimensional longitudinal frame above and below the frame of interest. In the transverse direction, the FE model extends from the side shell to the inner skin. Structures to be modelled include: side shell plating and side longitudinal stiffeners, web frames, web stiffeners and brackets and inner skin plating and attached longitudinals.

Only shell elements are used in the model. The mesh size is such to have at least three elements along web height of side shell longitudinal stiffeners. Quadrilateral elements are to be used whenever possible with aspect ratio of sides smaller than 3:1. Finite element model of side shell structure created according to the described principles is shown in the Figure 1.

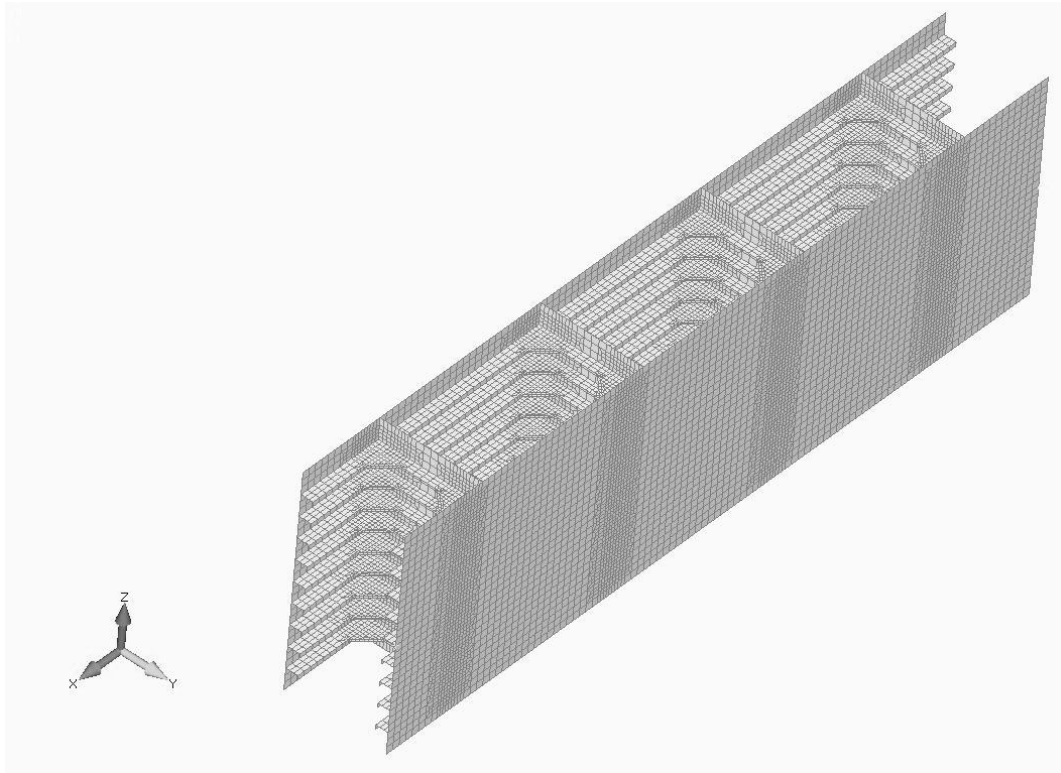

Fig. 1 Finite element model of side shell structure

Slika 1. Model konačnih elemenata konstrukcije boka broda

Boundary conditions prevent rigid body motion of the model while permitting the longitudinal frame to flex as it would if the entire structure had been modelled. Thus, the top and bottom cut planes apply complete translational fixity, but allow rotation about the vessel's longitudinal axis. This represents the rigidity of the horizontal stringers bounding the vertical model extent. The forward and aft cut planes apply a symmetric condition with respect to the plane perpendicular to the vessel's longitudinal direction. This represents that the structure is continuous in the vessel's longitudinal direction.

Material nonlinearity results from the nonlinear relationship between stress and strain once the elastic yield limit of the material has been reached. The behaviour of materials beyond yield is typically characterized by the slope of the stress-strain curve that indicates the degree of hardening. In general it is recommended to use an elastic-perfectly-plastic material model for shipbuilding steel that does not account for strain hardening effects. This simplification yields conservative results.

3. Loading of the model [2]

Designer goal is to achieve optimum design and to avoid heavier and less producible structure. Such balanced structure should be based on the realistic local load distribution. For the purpose of designing a side longitudinal and its end connections to web frames, the ice loads may be represented as line loads acting on the side longitudinal within the ice belt. The ice load per unit length used in calculating the scantlings is given as $F = p_{max} \cdot h$ where p_{max} is the ice pressure depending on the hull area, ship displacement and propulsion power, while h is a load height given by the ice class. The FE model loaded by the line load is presented in Figure 2.

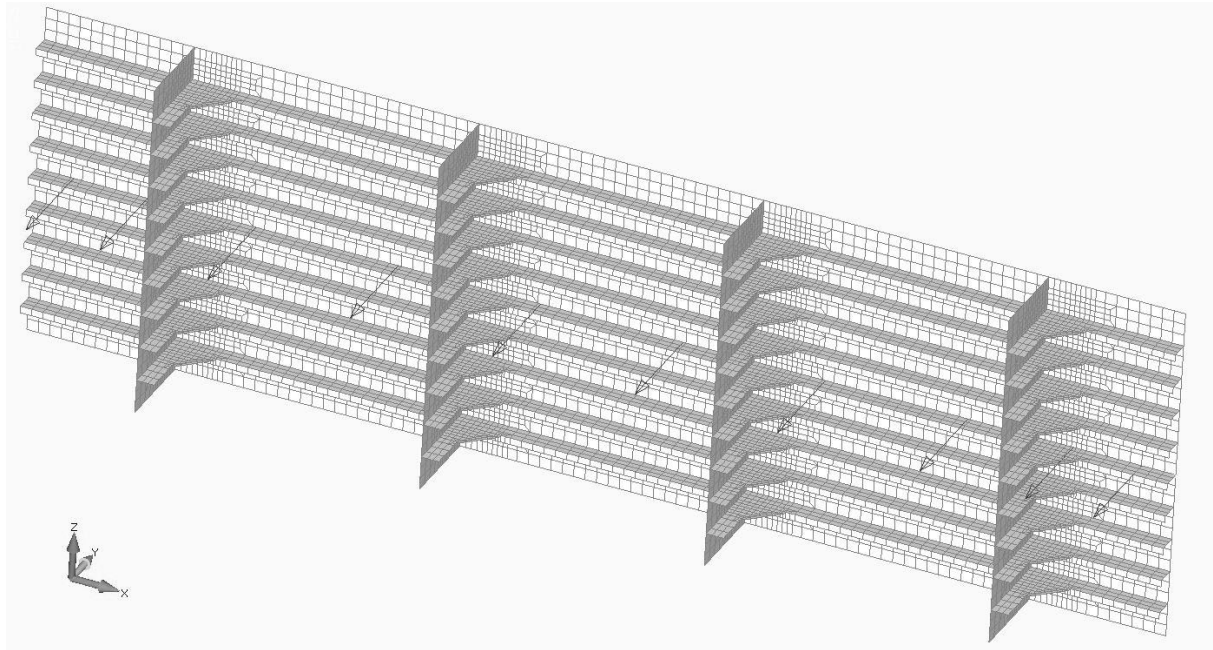

Fig. 2 Line load on the finite element model

Slika 2. Linijsko opterećenje modela konačnih elemenata

For the purpose of designing side shell plating, the applied extreme ice pressure is three times the standard design ice pressure defined in the ice class rules. The pressure is to be applied as patch load between two longitudinals, where load length is equal to two times the longitudinal spacing, while the load height is given by the ice class. The FE model loaded by the pressure load is presented in Figure 3.

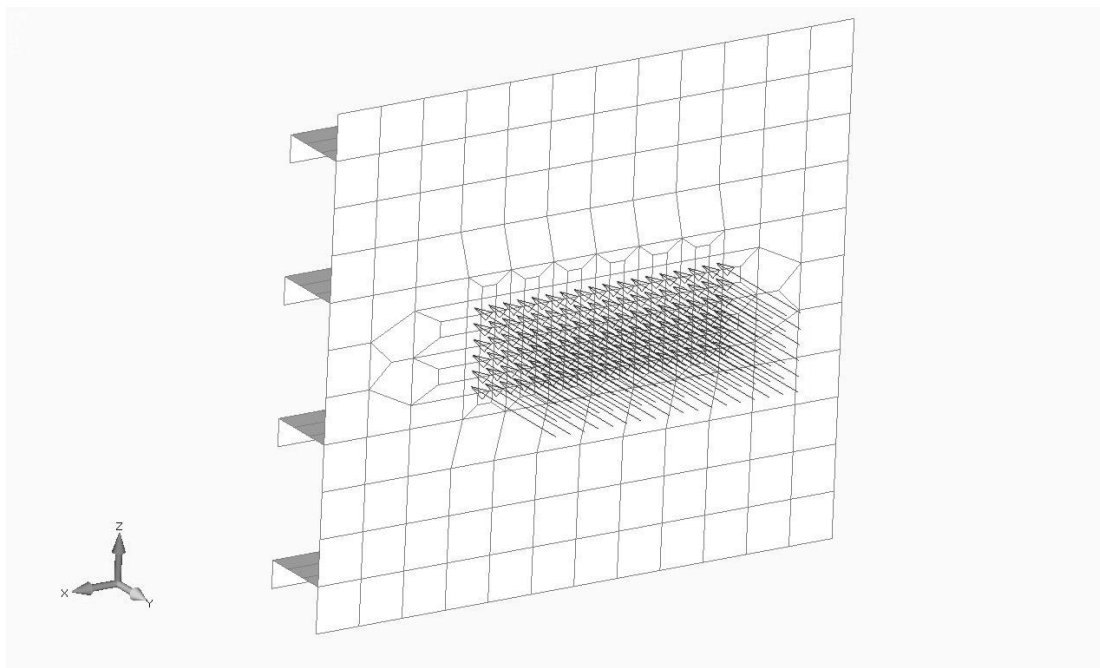

Fig. 3 Pressure load on the finite element model

Slika 3. Površinsko opterećenje modela konačnih elemenata

Nonlinear analysis is usually more time-consuming than linear analysis. The nonlinear solution, if yield stress is exceeded, will require a series of iterative steps where the load is incrementally applied. Within each load step, a series of sub-iterations may be required in order to reach equilibrium convergence with the current load step. At the end of each incremental step, deflection at any point of the structure may be obtained as a function of the load level. Usually, the maximum deflections are requested as well as permanent deflection remaining on structure after the unloading process. Loading and unloading of the model is schematically presented in the Figure 4 for the case of patch pressure on the side shell plating. Similar diagram is valid also for line load on side longitudinals.

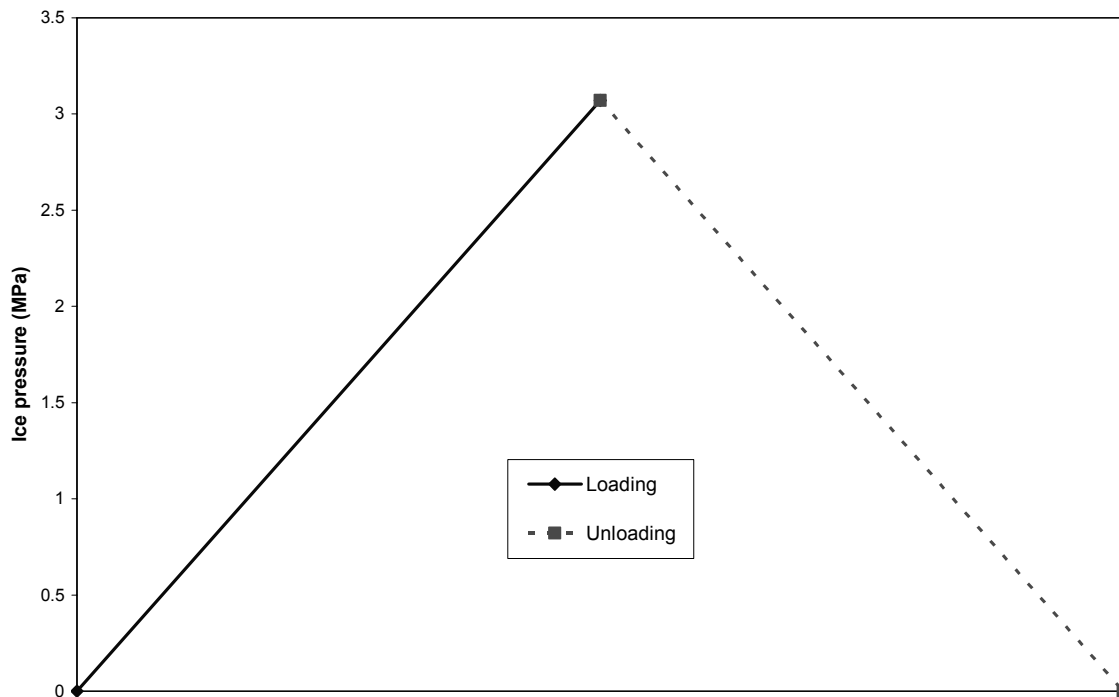

Fig. 4 Variation of the pressure load

Slika 4. Promjenjivost površinskog opterećenja

4. Acceptance criteria [2]

Following procedure is recommended to demonstrate acceptability of the proposed design of the side shell longitudinal:

1. design side shell according to the existing ice class rules. Normally, design includes reduced longitudinal spacing and brackets.
2. calculate load-deflection curve for "rule" design using described NFEM procedure.
3. re-design side shell structure usually with increased longitudinal spacing, increased size of longitudinals and with or without brackets.
4. calculate load-deflection curve for modified design using described NFEM procedure.
5. if maximum deflection and permanent plastic deformation of modified design are below values obtained for "rule" design, then re-designed structures is considered as acceptable.

The procedure for acceptance of side shell plating is simpler, as it is requested that permanent deformation is less than 2% of the longitudinal spacing.

5. Presentation of results

Side shell structure of the Aframax oil tanker analysed in the present paper is firstly designed for ICE-1C notation according to the rules for classification of ships ("rule" design). The structure is then re-designed and structural adequacy is checked using direct calculation by NFEM ("alternative" design).

The "rule" design has longitudinal spacing of 450mm, while brackets are used to connect longitudinals and web frame stiffeners. The "alternative" design has longitudinal spacing of 850mm. There are two main advantages of the "alternative" design comparing to the "rule" design:

the spacing of longitudinals is the same in the "ice belt" region as in other ship areas.

brackets connecting longitudinals and web frame stiffeners are not required.

These improvements could simplify fabrication procedure and reduce costs.

The NFEM analysis of the side shell structure is performed using Femap with NX Nastran software ver. 9.31. Design line load for shell longitudinals reads 312 kN/m, while design patch pressure for side shell plating reads 3.07MPa. Design loads are calculated according to the Guidance Notes [2].

Load-maximum deflection curves for side longitudinal for "rule" and "alternative" designs are presented in Figure 5. First, "alternative" design with initial shell thickness ($t=17.5$) is analysed, after which final "alternative" design is proposed with shell thickness increased in order to satisfy acceptance criteria of side shell plating. It may be seen that the maximal deflections and permanent deformations of proposed "alternative" design are lower than corresponding values of the "rule" design. Therefore, "alternative" design of the side longitudinals is acceptable.

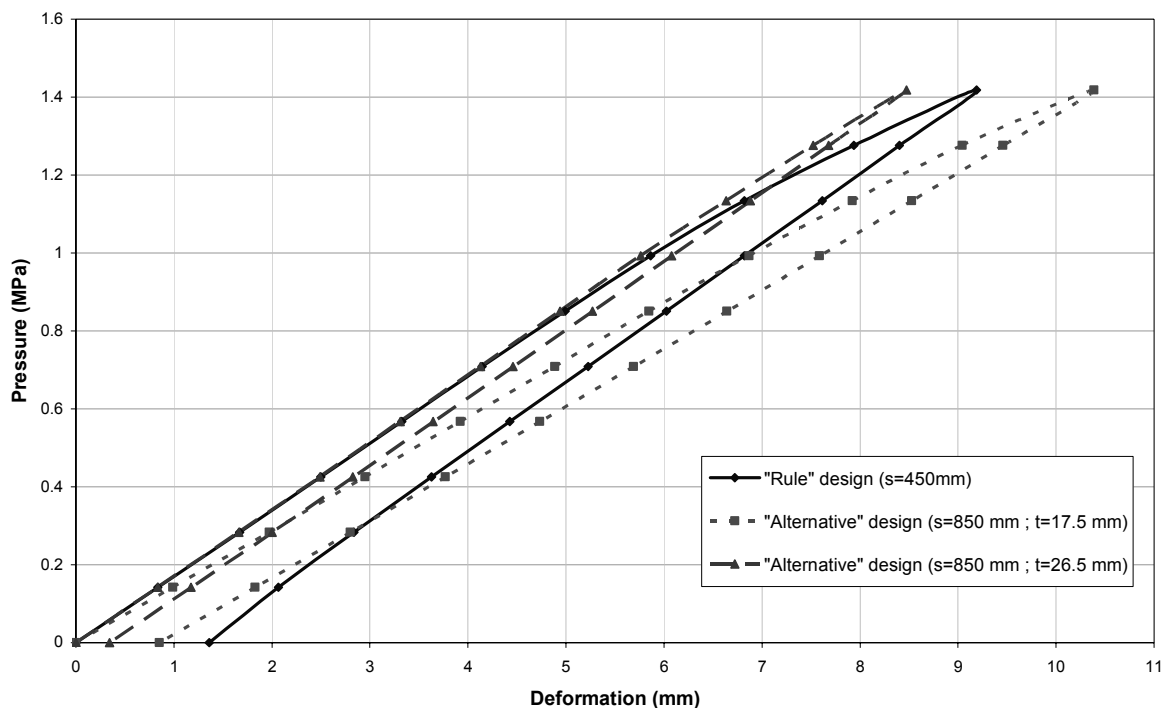

Fig. 5 Load-maximum deflection curves for the side shell longitudinal

Slika 5. Krivulje opterećenje-maksimalni progib za uzdužnjak vanjske oplate

Von Mises stresses on the deformed model are presented in the Figures 6 & 7 for "rule" and "alternative" designs respectively.

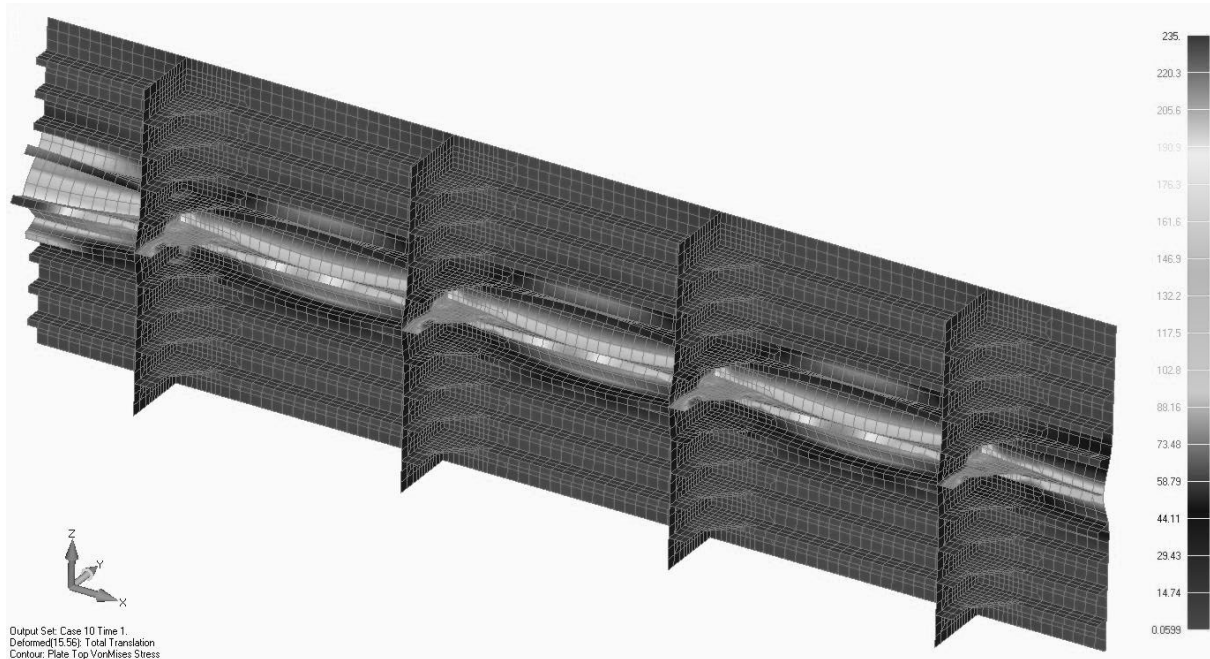

Fig. 6 Von Mises stresses on deformed model ("rule" design)

Slika 6. Von Misesova naprezanja na deformiranom modelu ("rule" projekt)

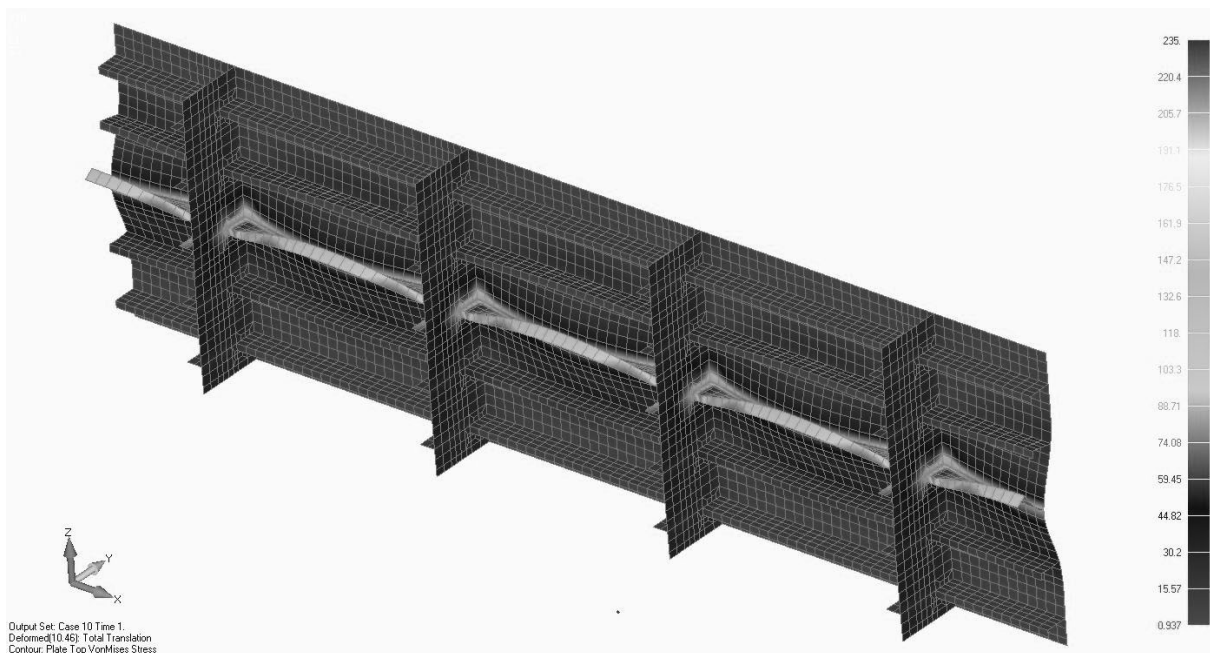

Fig. 7 Von Mises stresses on deformed model ("alternative" design)

Slika 7. Von Misesova naprezanja na deformiranom modelu ("alternative" projekt)

Besides side shell longitudinals, side shell plating is also affected by increasing spacing of longitudinals. Therefore, side shell plating thickness should be increased using similar design procedure as for the longitudinals. Side shell plate thickness of the "rule" design reads 17.5mm, while thickness of "alternative" design is increased to 26.5mm. Load-maximum deflection curves for side shell plating for "rule" and "alternative" designs are presented in

Figure 8. As permanent deformations of "alternative" design is less than 2% of stiffener spacing (17mm), it may be concluded that the "alternative" design is satisfactory and acceptable. Intermediate results, with increased spacing of longitudinals and initial thickness (17.5mm) are also shown in the Figure 8, leading to the unacceptable large deformations.

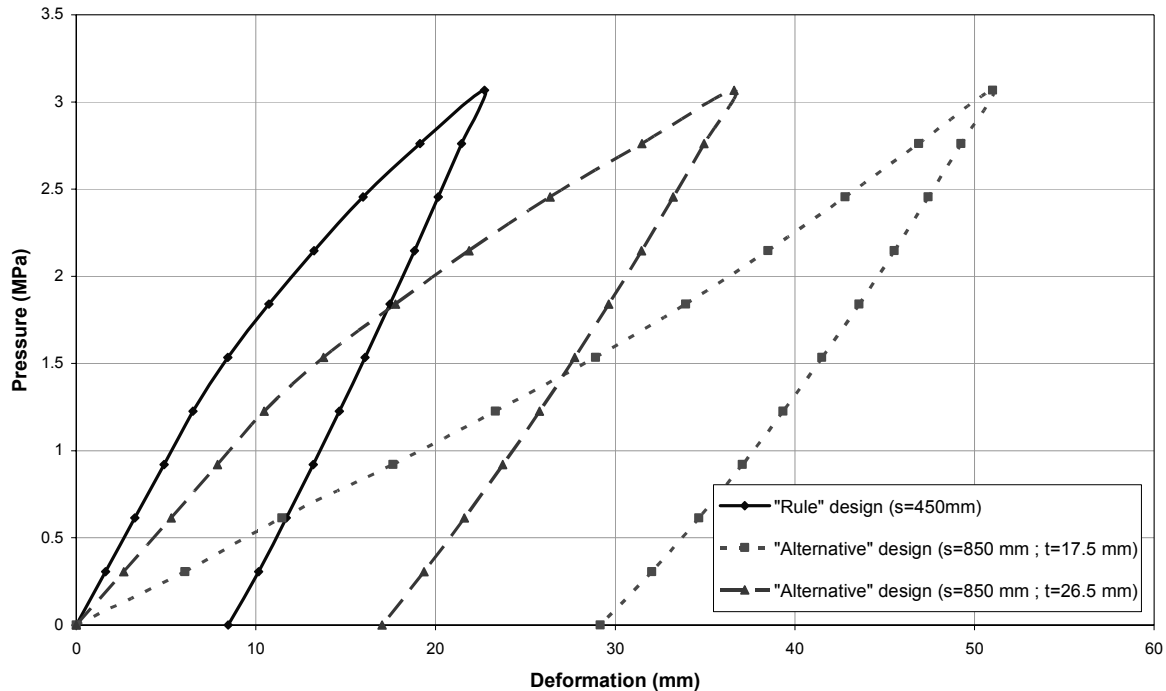

Fig. 8 Load-maximum deflection curves for the side shell plating

Slika 8. Krivulje opterećenje-maksimalni progib za oploćenje vanjske oplate

Von Mises stresses on the deformed model are presented in the Figures 9 & 10 for "rule" and "alternative" designs respectively.

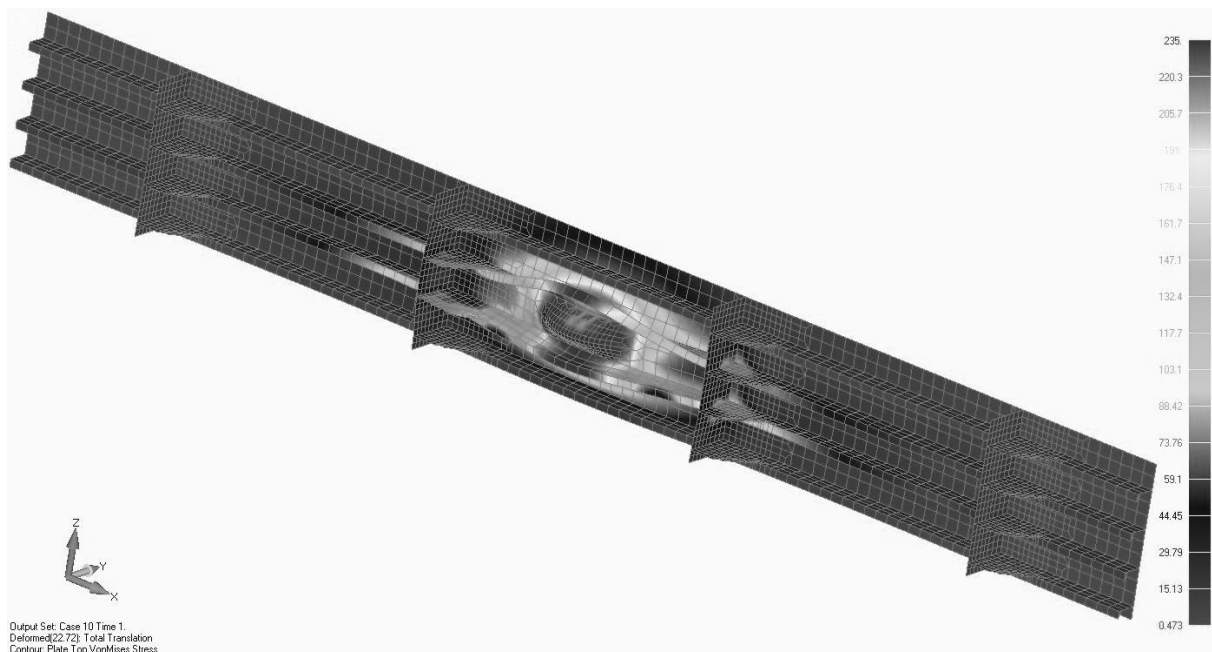

Fig. 9 Von Mises stresses on deformed model ("rule" design)

Slika 9. Von Misesova naprezanja na deformiranom modelu ("rule" projekt)

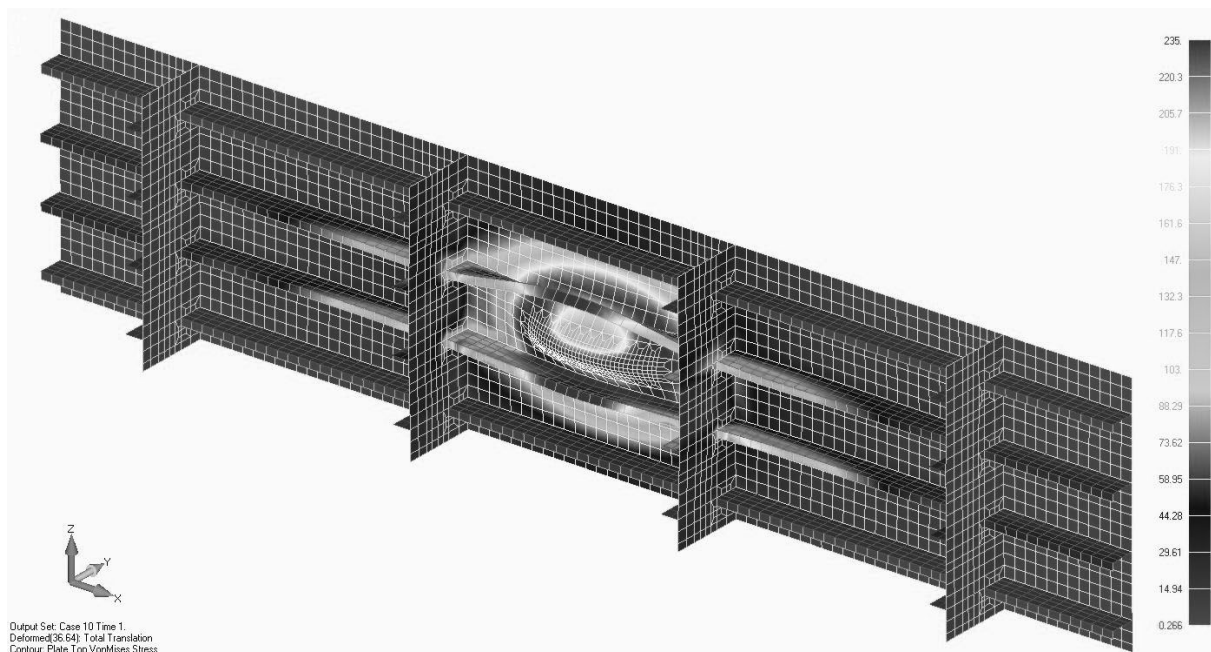

Fig. 10 Von Mises stresses on deformed model ("alternative" design)

Slika 10. Von Misesova naprezanja na deformiranom modelu ("alternative" projekt)

6. Conclusions

The paper describes procedure for designing side shell structure of an oil tanker with ice notation using NFEM. The approach is based on the requirement that the maximal and permanent deflections of such designed side shell structure due to the ice loads are similar to those of the structure designed according to the rule formulae.

The procedure is employed on the example Aframax tanker with ICE-1C notation and it is proved to be efficient tool for structural design optimization. It enables wider longitudinal spacing and design without brackets between longitudinals and web frame stiffeners. The proposed method enables also rational dimensioning of the side shell plating thickness. Eventually, NFEM could lead to the considerable reduction of fabrication costs and/or steel weight reduction of an oil tanker with ice notation comparing to the conventional rule approach.

REFERENCES

- [1] G. Wang & C.J. Wiernicki, Using Nonlinear Finite Element Method to Design Ship Structures for Ice Loads, *Transactions SNAME 112*, 2005., pp. 113-116.
- [2] ABS. *Guidance Notes on ICE Class*, 2005 (with 2008 updates).
- [3] P. Kujala, Safety of ice-strengthened shell structures of ships navigating in the Baltic Sea, in: *Advanced Ship Design for Pollution Prevention*, ed. Guedes Soares & Parunov, Taylor & Francis Group, London, UK, 2010.

*Paul Jurišić, Croatian Register of Shipping, Marasovićeve 67, Split,
Joško Parunov, University of Zagreb, Faculty of Mechanical Engineering and Naval
Architecture, I. Lučića 5, Zagreb*

LONG-TERM PREDICTION OF GLOBAL CORROSION WASTAGE OF OIL TANKERS

Summary

The paper describes investigation of global corrosion wastage of three oil tankers with single-hull structure built in eighties. Analysis of data is based on existing thickness measurements of hull elements reduction from Croatian Register of Shipping (CRS) file, gauged on periodic dry-docking and close-up surveys of ships in service after 10, 15 and 20 years. Hull girder section modulus (HGSM) is determined as function of time taking into account the lifetime of protective coatings. The obtained results are compared to the available theoretical non-linear corrosion models in order to predict the long-term corrosion wastage progression. The results of this study can be used when planning ship hull inspection of oil tankers in service.

Key words: corrosion wastage, hull girder section modulus (HGSM), oil tanker

DUGOROČNO PREDVIĐANJE GLOBALNIH ISTROŠENJA TRUPA TANKERA

Sažetak

Opisan je postupak analize korozivskih istrošenja tri tankera s jednostrukom oplatom izgrađenih osamdesetih godina. Obrada podataka temelji se na postojećim izmjerama debljina elemenata trupa iz baze Hrvatskog Registra Brodova (HRB) s periodičnih suhих dokovanja i pregleda brodova u službi nakon 10, 15 i 20 godina. S obzirom da su u model unesene vrijednosti korozivskih istrošenja u različitim fazama vijeka trajanja broda određen je gubitak momenta otpora poprečnog presjeka kao funkcija vremena, uzimajući u obzir vijek trajanja zaštitnog premaza. Za predviđanje napredovanja korozivskog istrošenja odnosno općenitog trenda smanjenja momenta otpora glavnog rebra na temelju rezultata dobivenih navedenom analizom, korišten je dostupni teorijski nelinearni korozivski model. Rezultati ove studije mogu se koristiti kod planiranja inspekcijskih pregleda brodskog trupa tankera u službi.

Ključne riječi: korozivska istrošenja, moment otpora poprečnog presjeka, tanker.

1. Introduction

Damages to ships due to corrosion are very likely and the possibility of accident increases with the aging of ships. Statistics reveal that corrosion is the number one cause for marine casualties in old ships. The consequences of corrosion wastage can be very serious in some circumstances. Severe corrosion can result in deck cracks across almost the entire ship width and also consequently result in the loss of ships. Figure 1 shows the underdeck area of 20-year-old tanker. The deck plates and longitudinals suffered various degrees of corrosion. In some locations, the web plate of deck longitudinal was totally wasted away. This caused loss of support of deck plates from longitudinals. The unsupported spans of the deck plate increased and effectively decrease in buckling strength. In heavy seas, buckling repeatedly occurred under the action of the cyclic wave loads. Plastic deformation accumulated and eventually cracks appeared.

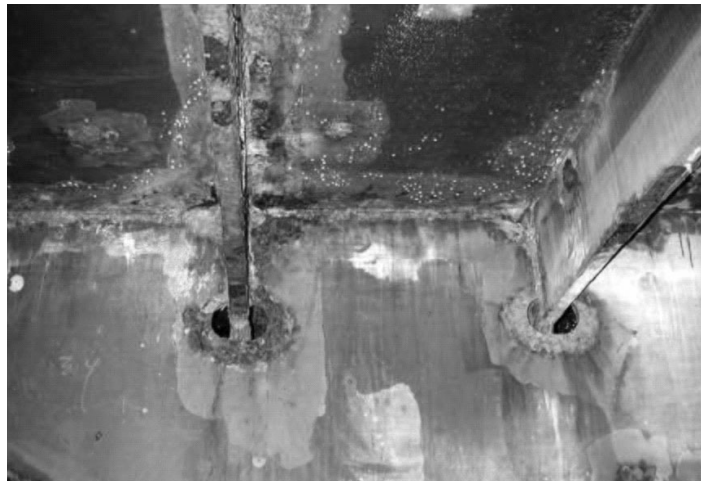

Fig. 1 Heavily corroded under-deck of 20 years old oil tanker

Slika 1. Uznepredovala korozija potpalublja 20 godina starog tankera

Hull girder section modulus (HGSM), as fundamental measure of the ship longitudinal strength deteriorate over time due to corrosion. Traditional engineering and analysis use simplified deterministic approaches to account for this time-variant random process. In most cases some nominal values are predefined for corrosion additions. Thus, ship classification rules, including newly developed Common Structural Rules (CSR) for Double-hull Oil Tankers assume constant loss of HGSM throughout the whole ship lifetime [1]. Structural assessment in the ship structural design phase is performed using such "net" HGSM. Although "rule" approach is practical, it is obviously not realistic, as HGSM loss is actually time-dependant non-linear function [2]. There is a clear tendency nowadays to adopt theoretical non-linear models in order to predict the long-term corrosion wastage progression and associated loss of HGSM. Such direct approach for corrosion progression could be useful tool for classification societies and ship owners in order to predict long-term behaviour of hull structure and to decide weather the renewal of the hull structure is necessary and when would be the optimal time for the repair [3]. Furthermore, such direct approach has potential to facilitate application of more accurate computational methods in design and analysis of oil tankers [5].

Practical applicability of the time-dependant HGSM concept is investigated in the present study. This is done in a way that HGSM losses of three ships in service are calculated

based on measurements after 10, 15 and 20 years. HGSM losses are then compared to the non-linear functions that are recently proposed based on measurements on large number of single hull oil tankers [2]. Furthermore, new functions are developed based on HGSM losses from the present study measured after 10 and 15 years. The main expected result of this research is the development of the method capable to predict HGSM after 20 or 25 years of service based on measurements collected in the history of each ship.

2. Assessment of HGSM loss

Structural configuration of all three analysed ships is typical for single-hull oil tankers, where central tanks along cargo hold areas are cargo oil tanks, while wing tanks can serve as ballast or cargo oil tanks, see Fig. 2.

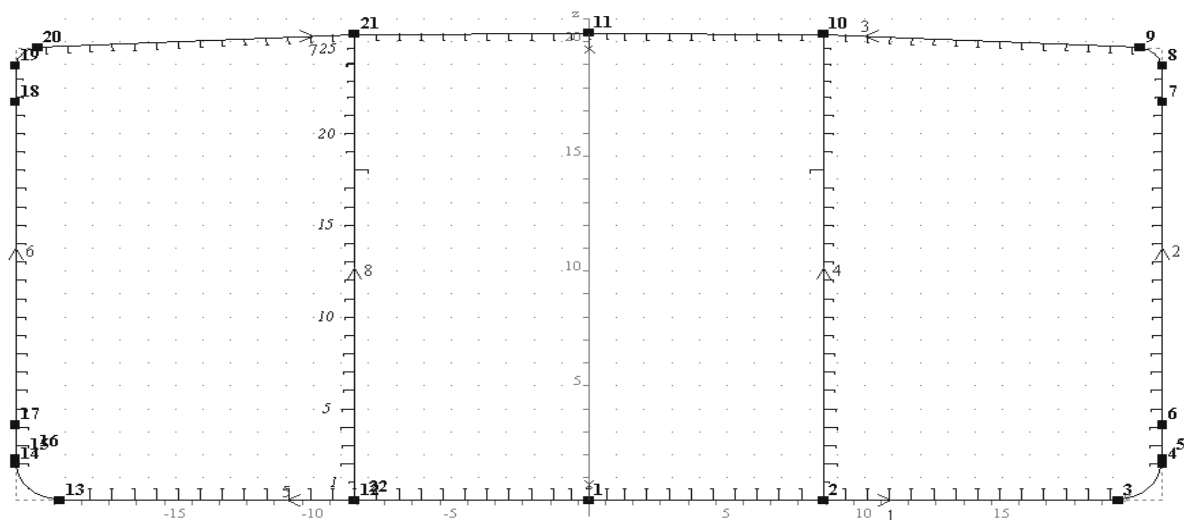

Fig. 2 Midship section of single-hull oil tankers

Slika 2. Glavno rebro tankera s jednostrukom oplatom

In the present study, HGSMs in cargo space are calculated with the program for the 2D sectional analysis MARS of classification society Bureau Veritas (BV) [8]. Firstly, the as-built HGSM is calculated. Then, thickness of structural elements (plates and longitudinals) contributing to the longitudinal strength are modified according to the results of thickness measurements from Croatian Register of Shipping (CRS) file. Gauging records were performed on periodic dry-dockings and close-up surveys of ships in service after 10, 15 and 20 years. Corrosion model of the ships was performed for the transverse sections with combination of central tanks as cargo oil tanks and wing tanks as ballast tanks.

Typical midship section of one of ships with corroded thickness of plate elements is presented in the Figure 3.

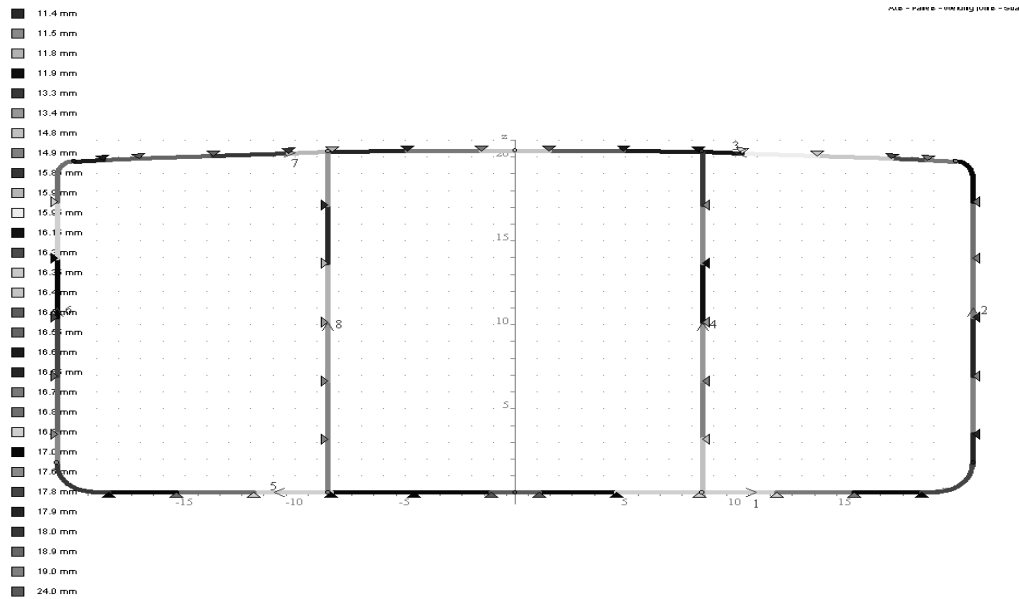

Fig. 3 Gauged plate's thickness of transverse section for 20 years old tankers.

Slika 3. Izmjerene debljine limova poprečnog presjeka 20 godina starog tankera

The aging effect is measured by the HGSM loss, which is the ratio of the as-gauged HGSM over the as built:

$$R(t) = 1 - \text{HGSM}(\text{as-gauged at year } t) / \text{HGSM}(\text{as-built}) \tag{1}$$

Results for measured $R(t)$ for three ships after 10, 15 and 20 years are presented in the Table 1.

Table 1 Measured $R(t)$ for three ships

Tablica 1. Izmjereni $R(t)$ za tri broda

Years of measured	$R(t)$ -Ship 1	$R(t)$ -Ship 2	$R(t)$ -Ship 3
10	0.0151	0.0145	0.0161
15	0.0225	0.0290	0.0445
20	0.0410	0.0470	0.0592

3. Time-dependant HGSM

HGSM loss is determined as a function of time taking into account the lifetime of protective coatings. The following equation for the HGSM loss after t years of ship service is proposed based on the gauging results from all longitudinally-effective structural components on 2195 transverse sections of 211 single-hull oil tankers [2]:

$$R(t) = C(t-t_0)^I \tag{2}$$

where $R(t)$ is the HGSM loss at age t , while t_0 is the year when HGSM starts to deviate from the as-built condition. C and index I are constants that can be determined according to the data set. Large data set is collected in ABS' Safe hull Condition Assessment Program (CAP) and results are presented as average parameters of the Equation (2) for four different levels of the corrosion severity, Table 2 and Figure 4 [2].

Table 2 Parameters of Equation (1) for different levels of corrosion severity

Tablica 2. Parametri jednadžbe (1) za različite razine oštine korozije

Corrosion severity	C	t ₀ , years	I
Slight	0.62	6.5	0.67
Moderate	0.80	5	0.75
Severe	0.84	3.5	0.83
Extreme	0.90	2	0.91

Results from the curves presented in Figure 4 indicate that corrosion loss of HGSM will be less than 10% during whole lifetime of the vessel, in cases of slight and moderate corrosion severities. For severe corrosion rate, HGSM will become less than 90% of its initial value after approximately 23 years while in extremely unfavourable corrosion conditions 10% loss limit will be exceeded after 18 years. This value of 10% of permissible loss of initial HGSM represents important industry standard that must be respected during whole lifetime of the ship.

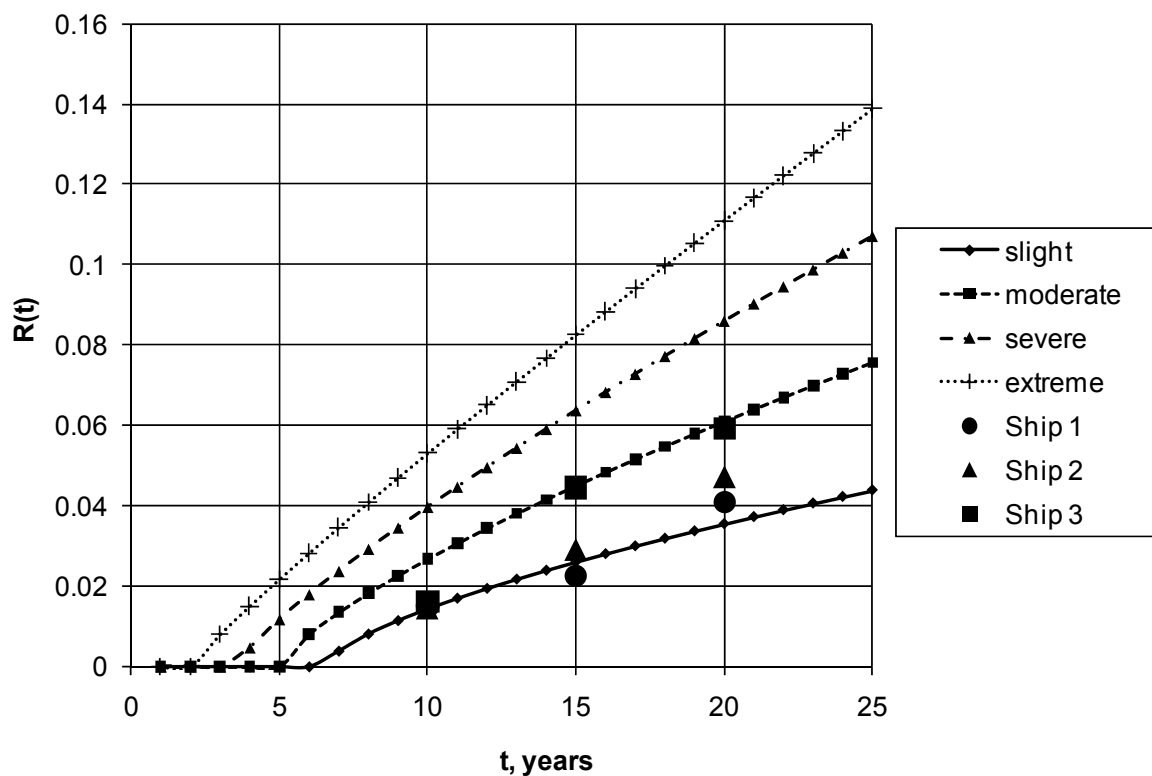

Fig. 4 HGSM loss for different levels of corrosion severity

Slika 4. Gubitak momenta otpora poprečnog presjeka za različite oštine korozije

In the Figure 4, measured results obtained for three oil tankers considered in the present study are also shown. It may be seen that measured corrosion loss is always between prediction curves for slight and moderate corrosion levels.

Ship no. 1 in Figure 4 (circles) has slight corrosion wastage for all three measurement points (10, 15 and 20 years) and prediction curve represent approximately least square fit through these measurement points.

Measurement points for ship no. 2 (triangles) lie approximately on straight line and in long-term prediction it could be expected that the corrosion approaches curve for moderate corrosion.

Results obtained for ship no. 3 (squares) are very interesting. Measurements points seem to be placed on the curve that starts to grow from zero at approximately 8 years, that could represent coating lifetime in that particular case. After expiration of the coating lifetime, the corrosion is developed quite rapidly (until about 15 years) but then corrosion rate is reduced and corrosion loss approximately follows curve for moderate corrosion.

In order to investigate further improvement of predictions, curves similar to those from Figure 4 are fitted through measurement points of HGSM loss at 10 and 15 years. Results are presented in the Table 3 and Figure 5.

Table 3 Parameters of Equation (1) for different ships based on measurement after 10 and 15 years

Tablica 3. Parametri jednadžbe (1) za različite brodove prema mjerenjima nakon 10 i 15 godina službe

Corrosion severity	C	t ₀ , years	I
Ship 1	0.60	5	0.58
Ship 2	0.44	6	0.86
Ship 3	0.92	8	0.81

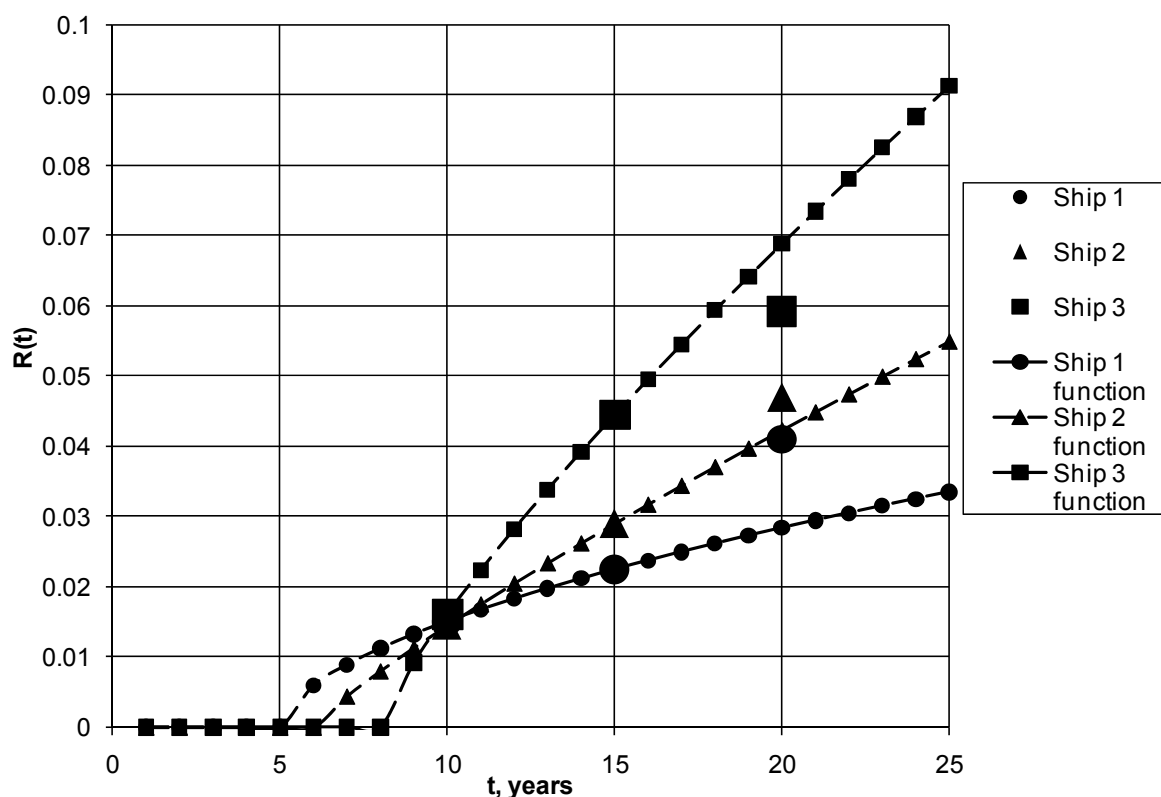

Fig. 5 Measured and predicted HGSM losses for different ships

Slika 5. Izmjereni i predviđeni gubitak momenta otpora poprečnog presjeka za različite brodove

It appears from Figure 5 that HGSM loss at 20 years for ship no. 1 is underestimated by prediction curve. Much better agreement is obtained by curve for slight corrosion from Figure 4.

Prediction of HGSM loss in 20 years for ship no. 2 is quite good. Curve is almost linear from time of coating breakdown (6 years).

Results for ship no. 3 indicate that the coating lifetime for that ship could be the longest, but after the breakdown of the coating corrosion progression is very fast. Prediction curve would overestimate actual HGSM loss.

It should be mentioned that there is a large uncertainty associated to HGSM loss as the corrosion loss is different for each transverse section of the ship hull. It may be assumed, however, that surveyors of analysed ships measured sections with representative (average) corrosion losses. More research is required to improve reliability of long-term predictions of corrosion losses.

4. Conclusion

Each individual oil tanker, particularly if it is an aged one of single side skin type, represents potential huge threat to the environment. Classification societies most seriously take into consideration the corrosion wastage as one of the very important degradation factors for ship structural strength [9][10]. Therefore, it is of interest to examine how the corrosion wastage of ship structural elements propagates through the years.

The present paper proposes the methodology how to efficiently anticipate long-term corrosion wastage using thickness measurement results from ship history. Long-term non-linear corrosion model is fitted through measured HGSM losses of three single hull tankers after 10 and 15 years of service and predictions are then compared to the measured HGSM losses after 20 years. This approach could lead to more refined and more rational inspection and repair planning of existing ships. The procedure represents an improvement compared to CSR, as the rules assume constant corrosion loss throughout whole ship's lifetime, being an unrealistic assumption.

It is shown in the paper that measured corrosion wastage generally agrees well with proposed curves for long-term HGSM loss. However, further researches are required since large uncertainties regarding the coating lifetime and rate of corrosion propagation are noticed.

REFERENCES

- [1] American Bureau of Shipping, Det Norske Veritas, Lloyd's Register, 2006. *Common Structural Rules for Double Hull Oil Tankers*.
- [2] G. Wang, A.-K. Lee, Lj. Ivanov, T.J. Lynch, C. Serratella, & R. Basu, 2008. *A statistical investigation of time-variant hull girder strength of aging ships and coating life*. Marine Structures 21, p. 240-256.
- [3] Y. Garbatov & C. Guedes Soares, Risk based maintenance of deteriorated ship structures accounting for historical data. in: *Advanced Ship Design for Pollution Prevention*, ed. Guedes Soares & Parunov, Taylor & Francis Group, London, UK, 2010. p.131-147.
- [4] J. Parunov, P. Mage, C. Guedes Soares, 2008, Hull girder reliability of an aged oil tanker, *Proceedings of the 27th International Conference on Offshore Mechanics and Arctic Engineering, (OMAE2008)*, ASME, Estoril, Portugal, Paper no. 57183.
- [5] J. Parunov, K. Žiha, P. Mage, Corrosion wastage of oil tankers – A case study of an aged ship // *IMAM 2007* / Guedes Soares & Kolev (ed.), Varna: Taylor & Francis Group, 2008. p. 271-276.

- [6] J. Parunov, K. Žiha, P. Mage, P. Jurišić, Hull girder fatigue of corroding oil tanker. in: *Advanced Ship Design for Pollution Prevention*, ed. Guedes Soares & Parunov, Taylor & Francis Group, London, UK, 2010. p.149-154.
- [7] IACS PR No. 34 (Rev.3 Corr.1 Jul. 2008) – Procedural Requirement on Application for the IMO Performance Standard for Protective Coatings (PSPC), *Resolution MSC.215(82)*, under IACS Common Structural Rules for Bulk Carriers and Oil Tankers.
- [8] Bureau Veritas 2003. MARS 2000, Paris.
- [9] Croatian Register of Shipping 2009. *Rules for the Classification of Ships, Part 2-Hull*.
- [10] International Maritime Organization (IMO), Resolution MSC.105(73), 2000. *The guidelines on the enhanced program of inspection during surveys of bulk carriers and oil tankers*, London.