



International Institute for  
Applied Systems Analysis  
www.iiasa.ac.at

# **Simulating the Socio-Economic and Biogeophysical Driving Forces of Land-Use and Land-Cover Change: The IIASA Land-Use Change Model**

**Fischer, G., Ermoliev, Y.M., Keyzer, M.A. and  
Rosenzweig, C.**

**IIASA Working Paper**

**WP-96-010**

**January 1996**



Fischer, G., Ermoliev, Y.M., Keyzer, M.A. and Rosenzweig, C. (1996) Simulating the Socio-Economic and Biogeophysical Driving Forces of Land-Use and Land-Cover Change: The IIASA Land-Use Change Model. IIASA Working Paper. WP-96-010 Copyright © 1996 by the author(s). <http://pure.iiasa.ac.at/5015/>

**Working Papers** on work of the International Institute for Applied Systems Analysis receive only limited review. Views or opinions expressed herein do not necessarily represent those of the Institute, its National Member Organizations, or other organizations supporting the work. All rights reserved. Permission to make digital or hard copies of all or part of this work for personal or classroom use is granted without fee provided that copies are not made or distributed for profit or commercial advantage. All copies must bear this notice and the full citation on the first page. For other purposes, to republish, to post on servers or to redistribute to lists, permission must be sought by contacting [repository@iiasa.ac.at](mailto:repository@iiasa.ac.at)

# Working Paper

**SIMULATING THE SOCIO-ECONOMIC AND  
BIOGEOPHYSICAL DRIVING FORCES OF  
LAND-USE AND LAND-COVER CHANGE:**

**THE IIASA LAND-USE CHANGE MODEL**

*Günther Fischer, Yuri Ermoliev,  
Michiel A. Keyzer and Cynthia Rosenzweig*

WP-96-010  
January, 1996



International Institute for Applied Systems Analysis • A-2361 Laxenburg • Austria

Telephone: +43 2236 807 • Fax: +43 2236 71313 • E-Mail: [info@iiasa.ac.at](mailto:info@iiasa.ac.at)

**SIMULATING THE SOCIO-ECONOMIC AND  
BIOGEOPHYSICAL DRIVING FORCES OF  
LAND-USE AND LAND-COVER CHANGE:  
THE IIASA LAND-USE CHANGE MODEL**

*Günther Fischer, Yuri Ermoliev,  
Michiel A. Keyzer\* and Cynthia Rosenzweig*

WP-96-010  
January, 1996

\* Professor Michiel Keyzer, Acting Director, Centre for World Food Studies, Vrije Universiteit (SOW-VU), Amsterdam, The Netherlands.

*Working Papers* are interim reports on work of the International Institute for Applied Systems Analysis and have received only limited review. Views or opinions expressed herein do not necessarily represent those of the Institute, its National Member Organizations, or other organizations supporting the work.



International Institute for Applied Systems Analysis • A-2361 Laxenburg • Austria  
Telephone: +43 2236 807 • Fax: +43 2236 71313 • E-Mail: [info@iiasa.ac.at](mailto:info@iiasa.ac.at)

## CONTENTS

1.	Introduction	1
2.	Previous modeling studies related to land-cover change	5
3.	On socio-economic and political driving forces	8
3.1	Urbanization	8
3.2	Policy issues	9
3.3	The role of technology	9
3.4	Regional land-use policy issues	10
4.	Basic concepts of welfare analysis and competitive equilibrium	13
4.1	A static competitive equilibrium model	13
4.2	Welfare programs and competitive equilibrium	15
4.3	Incorporating policy measures in welfare programs	17
4.4	Including trade in the welfare program	19
4.5	Non-rival consumption	20
5.	Spatial aspects of modeling land-use and land-cover change	21
5.1	Defining the spatial representation	21
5.2	Organization of spatial units	23
5.3	Representing commodity and resource flows	24
5.4	Implementation of the trade-pool approach	26
5.5	Construction of commodity balances	30
6.	Temporal aspects of land-use change	32
6.1	Intertemporal welfare analysis	33
6.2	T-period general equilibrium models	33
6.3	Specifying an intertemporal utility function	37
6.4	Population dynamics	38
6.5	Recursive dynamic equilibrium models	39
6.6	The welfare approach	40
7.	Modeling the dynamics of resource stocks	42
7.1	Production activities and resource dynamics	42
7.2	Resource accumulation and degradation	44
7.3	Resource migration	45
7.4	Resource conversion	46
8.	Representing land resources and land use	48
8.1	Describing land resources by site classes	48
8.2	Change in land characteristics over time	49
8.3	Defining land-use types and major land-use classes	49
8.4	Land-balance conditions and constraints on land use	52
8.5	Geographic representation of site classes	55

9.	Specification of supply and demand functions	57
9.1	Production in the LUC model	57
9.2	Modeling agricultural supply	59
9.3	Specifying yield relations	62
9.4	Consumer demand	64
10.	Risks and uncertainty	67
10.1	Sources of uncertainty	67
10.2	Variability in farm production conditions	69
10.3	Two-stage decision processes	70
10.4	Irreversible decisions	71
11.	Summary	74
	References	79

## 1. Introduction

In 1995, a new project *Modeling Land-Use and Land-Cover Changes in Europe and Northern Asia* (LUC) has been established at IIASA with the objective of analyzing the spatial characteristics, temporal dynamics, and environmental consequences of land-use and land-cover changes that have occurred in Europe and Northern Asia over the period 1900 to 1990 as a result of a range of socio-economic and biogeophysical driving forces. The analysis will then be used to project plausible future changes in land use and land cover for the period 1990 to 2050 under different assumptions of future demographic, economic, technological, social and political development. The study region, Europe and Northern Asia, has been selected because of its diversity in social, economic and political organization, the rapid changes in recent history, and the significant implications for current and future land-use and land-cover change.

Land-cover change is driven by a multitude of processes. Natural processes, such as vegetation dynamics, involve alterations in cover due to natural changes in climate and soils. However, changes of land cover driven by anthropogenic forcing are currently the most important and most rapid of all changes (Turner *et al.* 1990). Therefore, any sound effort to project the future state of land cover must consider the determinants of human requirements and activities, e.g., demand for land-based products such as food, fiber and fuel, or use of land for recreation.

In the past, major land-cover conversions have occurred as a consequence of deforestation to convert land for crop and livestock production; removal of wood for fuel and timber; conversion of wetlands to agricultural and other uses; conversion of land for habitation, infrastructure and industry; and conversion of land for mineral extraction (Turner *et al.* 1993). These human-induced conversions of land cover, particularly during the last two centuries, have resulted in a net release of CO<sub>2</sub> to the atmosphere, changes in the characteristics of land surfaces (e.g., albedo and roughness), and decreased biodiversity.

More subtle processes, termed land-cover modifications, affect the character of the land cover without changing its overall classification (Turner *et al.* 1993). For instance, land-cover degradation through erosion, overgrazing, desertification, salinization and acidification, is currently considered a major environmental problem. Although the effects

of land-cover modifications may be small at local scales, their aggregate impact may be considerable (Houghton 1991). For example, use of fertilizers locally has no significance for atmospheric concentrations of greenhouse gases. However, when practiced frequently in many locations, nitrogen fertilizer can make a significant contribution to emissions of nitrous oxide (N<sub>2</sub>O) globally.

The implementation of a comprehensive land-use change model poses a number of methodological challenges. These include the complexity of the issues involved and the large number of interacting agents and factors; the nonlinear interactions between prices, the supply of and the demand for land-based commodities and resources; the importance of intertemporal aspects; the intricacy of biogeophysical feedbacks; and the essential role of uncertainty in the overall evaluation of strategies.

The interaction mechanisms between biophysical cycles and economic processes have mainly been studied in dynamic simulation models that follow recursive chains of causation, where the past and present events determine what will happen tomorrow. Not surprisingly, many of these studies have led to dramatic predictions, basically because the agents whose behavior is described within the model are themselves assumed to be unable to predict at all. By contrast, in micro-economics it is usually assumed that agents do have the capacity to make informed predictions and to plan so as to avoid the probability of disaster in the future. However, even full information and rationality of individual choice are not always sufficient to avoid disaster. The coordination mechanisms that prevail among economic agents often tend to be of decisive importance.

The aim of this paper is to summarize the LUC project approach and to extend our earlier writings on modeling of land-use and land-cover change dynamics (Ermoliev and Fischer 1993; Fischer *et al.* 1993; Keyzer 1992, 1994). We discuss the adequacy and applicability of welfare analysis as a conceptual framework for the LUC project at IIASA. We recognize from the outset the complexity of socio-economic and environmental driving forces and the fundamental uncertainties involved in their spatial and temporal interactions (and outcomes). Unlike physical particles, economic agents have the ability to anticipate, and they possess the freedom to change their behavior. This inherent unpredictability, in particular the multiplicity of possible outcomes, calls for a normative approach, and for comparative policy analysis rather than exact prediction. Therefore, we



adopt an approach that enables the explicit representation of various policy measures, thus providing a means to search for 'better futures', i.e., for trajectories of future development that may alleviate environmental stresses while improving human welfare.

In applied studies, it is relatively easy to produce doomsday in a long-term model; a simple trend extrapolation will usually do. Finding an ideal solution is obviously more difficult, and also more challenging. We start from a first-best angle, assuming perfect foresight and perfect coordination through an intertemporal welfare program. By design, the analysis of intertemporal welfare programs provides ideal (i.e. best case) trajectories of demand, supply and resource use, in particular of land allocation. Then, no-action or business-as-usual scenarios are specified that start from present-day conditions and serve to highlight some of the threats that the system is currently facing. We call this 'bracketing' of the future between ideal and doomsday scenarios the *welfare approach*.

Welfare analysis has become an important tool in applied modeling studies. Welfare programs provide the opportunity to simulate social and economic driving forces of land-use change in a methodologically rigorous way. The adjustment of the program's welfare weights and other policy variables, to account for budget and other constraints of the agents, can lead to highly nonlinear processes. The sensitivity and robustness of these trajectories can be studied in comparison to analysis carried out with, for instance, recursive dynamic equilibrium models or other myopic approaches. The combination of defining an ideal reference solution derived from welfare analysis and the examination of its sensitivity to introducing myopic rules and behavioral assumptions seems to be a reasonable and policy-relevant approach to the comparative study of possible land-use and land-cover change trajectories.

In the following paper, Section 2 briefly describes various modeling studies with a strong relationship to land-cover change. Section 3 explains the basic ideas how to model the interactions between major driving forces and the allocation of land to competing alternative uses. A brief introduction to some concepts of competitive equilibrium and the welfare approach is given in Section 4. Spatial aspects of modeling land-use and land-cover change are discussed in Section 5. Section 6 deals with the temporal aspects of the LUC study. Section 7 introduces the concepts of resource accumulation and degradation. In Section 8 we elaborate on how to include land resources in the LUC model, and how to

specify various types of constraints related to land resources and land use. Next, Section 9 proceeds with the representation of land-based production sectors, agriculture and forestry, in the LUC model. We review the modeling of agricultural supply and propose methods to include technical and structural information in the model specification. In Section 10 we discuss various sources of uncertainty and their importance to making long-term strategic decisions. We also briefly discourse on unpredictability resulting from possible multiple equilibria and uncertainty of behavioral factors. Finally, in Section 11, we summarize the approach adopted in the LUC project.

## 2. Previous modeling studies related to land-cover change

It is hardly conceivable that any single model is capable of providing a comprehensive global, yet geographically detailed, assessment of land-use and land-cover change addressing all the complex issues involved. Yet, LUC-related regional, continental and global-scale models are not without exemplars. Such models have generally been built for specific purposes and have applied a wide range of methodological approaches and theoretical rigor.

Ever since the early calculations by Thomas Malthus in 1798 on the relation between land availability and population growth (Malthus 1982), many such models have been constructed. The Club of Rome models (Forrester 1971; Meadows *et al.* 1972) of the early 1970s marked a revival of this type of investigation that has subsequently been pursued by many researchers. Global climate change has more recently been a major impetus for land-use/land-cover studies.

Early climate change impact studies addressed only a few aspects of the Earth system, but were later refined by including the transient response of ecosystems and agrosystems and by accounting for the direct physiological effects of increasing atmospheric carbon dioxide on vegetation growth and water use. Early studies of the impacts of climatic change projected significant effects on the location and extent of natural ecosystems and agrosystems (e.g., Emanuel *et al.* 1985; Solomon 1986; Parry *et al.* 1988a,b). These studies focused on the biophysical processes that drive potential vegetation shifts, but most did not account explicitly for changes in land use driven by human demands and economic activities.

An example of a combined biophysical and economic national assessment is the study of the effects of global climate change on U.S. agriculture (Adams *et al.* 1993). The study used a spatial optimization model representing production and consumption of 30 primary agricultural products including both crop and livestock commodities. The model consists of two components, a set of micro or farm-level models integrated with a national sector model. Production behavior is described in terms of the physical and economic environment of agricultural producers for some 63 production regions of the United States. Availability and use of land, labor and irrigation water is determined by supply curves

defined at the regional level. The study evaluated the direct effects of potential climate change on U.S. agriculture, but did not investigate other driving forces such as urbanization nor possible implications and feedbacks of land-use change on the dynamics of the resource base such as the potential for competing demands for water.

An ambitious attempt to model complex relationships between agriculture and the rest of the economy is the IIASA global model of the world food and agriculture system (Fischer *et al.* 1988). The Basic Linked System (BLS) consists of a number of linked national models based on welfare economics and applied general equilibrium. The model system includes the dynamics of population and rural-urban migration, socio-economic factors, capital accumulation, and market clearing conditions, to project demand, supply and agriculture land use at aggregate national level. Recently, results from elaborate process crop models have been linked to the IIASA model to project climate change impacts on world food supply, demand, trade and risk of hunger (Rosenzweig *et al.* 1993; Fischer *et al.* 1994a). The BLS studies emphasized climate change impacts on agriculture only and did not assess future changes in land use and land cover associated with other sectors. Also, since land is only included as an aggregate resource and production factor in the BLS, the studies could not project environmental consequences of land-use change.

An integrated economic analysis of the potential impact of global warming on a four-state region of the United States (Missouri, Iowa, Nebraska, Kansas) is known as the MINK study (Rosenberg and Crosson 1991). The study included four sectors of the economy (agriculture, forestry, water, and energy) in the analysis, and aimed for a spatial representation of the relationships among these sectors and the interdependencies with regard to climatic conditions.

FASOM (forest and agriculture sector optimization model) is a dynamic, multi-market, multi-period, nonlinear programming model of the forest and agricultural sectors in the United States (Adams *et al.* 1994). The model employs 11 supply regions and a single national demand region. FASOM depicts the allocation of land to competing activities in both the forest and agricultural sectors. It has been developed to evaluate the welfare effects on producers and consumers and the market impacts of alternative policies for sequestering carbon in trees. Dealing with one aggregate consumer only, the model ignores income-formation processes. Also, it pays only limited attention to the spatial

aspects of land-use and land-cover change and the processes of resource accumulation or degradation.

Yet another set of models has been developed to assess the availability of natural resources suitable for food production and forestry. The basis of many of these models is the FAO Agro-ecological Zones (AEZ) approach (FAO 1978; FAO/IIASA/UNFPA 1982; Brinkman 1987; FAO/IIASA 1993). The AEZ approach estimates the capability of land units to grow crops and raise livestock, by comparing climate and soil characteristics to crop and livestock requirements. The method has been used in several applications, e.g., to analyze land use in the context of national and regional development planning (FAO/IIASA 1993; van Velthuis *et al.* 1995) and to determine crop distribution and yields under different climates (Leemans and Solomon 1993; Fischer *et al.* 1995).

Representing a process-oriented modeling approach applicable to larger regions, the CENTURY model assesses vegetation cover and soil organic matter dynamics in managed and unmanaged grassland ecosystems (Parton *et al.* 1987, 1988, 1993).

An integrated model system that explicitly addresses changes in land use and land cover at the global scale is IMAGE 2 (Alcamo 1994). The model includes a rule-based land-cover change module that is driven by the changing demand for agricultural commodities (Zuidema and van den Born 1994). The model aims to simulate the transient dynamics of atmospheric greenhouse gases, accounting for the major interactions within the Earth's system. The human driving forces are derived from assumed scenarios of future demographic, economic and technological developments projected on a broad regional basis.

Although IMAGE 2 is an ambitious starting point to integrating human and biogeophysical driving forces for projecting changes in land cover, it does not internally generate feedbacks among prices, demand behavior, supply response, and policy measures. Outcomes of these interactions are numerically sensitive and can hardly be captured by simple rules. Yet, these interactions represent important adjustment and adaptation mechanisms. The goal of the LUC model is to include such mechanisms within the dynamic structure of the simulation.

### **3. On socio-economic and political driving forces**

As mentioned in Section 1, human-driven alterations of land cover are currently the most important of all land-cover changes. There is a multitude of 'driving forces' of land-cover change to be captured in the LUC analysis. Researchers have grouped the anthropogenic forces driving land-use and land-cover changes into several categories: population change; level of affluence; technological change; economic growth; political and economic structure; and attitudes and values (Stern *et al.* 1992; Turner *et al.* 1993).

On the macro scale, the dominant driving force for land-use and land-cover change in most developing countries has been (and will continue to be) growth of consumer demand for agricultural and forestry products (Norse 1993). Consumer demand itself is a function of population size and income growth. In the developed countries, however, where growth in population and per capita demand for food and wood products is rather stagnant, the dominant driving force of land-use change is often policy-induced contraction of surplus production (for example, in the European Union) and privatization and economic restructuring (for example, in Eastern Europe and the former USSR).

#### **3.1 Urbanization**

Urbanization has been a global phenomenon over the last decades (e.g., Simpson 1993). Rapidly growing numbers of urban consumers are more and more determining the demand for food, fiber, fuel, and timber. A significant and growing fraction of production from agriculture and forestry is exchanged through domestic and international markets. Hence, commercial production and markets will play an increasingly important role as compared to the needs of rural subsistence producers. Consequently, prices of commodities and production inputs (seed, fertilizer, etc.) will ever more influence the decisions of consumers and producers in regard to land use and resource allocation. These factors must be adequately captured in order to model land-use and land-cover change realistically.

### **3.2 Policy issues**

The main economic actors, producers and consumers, operate within the legal and institutional frameworks created by governments and international agencies<sup>1</sup>. Subsidies and taxation create economic incentives and distortions that affect resource allocation and levels of use. The many-fold increase of soybean production in Brazil during the 1970s and 1980s and the dramatic destruction of tropical rainforests are often-cited examples of far-reaching consequences of governmental intervention policies on land use (e.g., in FAO 1995). Environmental standards for pollutants, as well as legal and economic instruments to achieve them, provide stimuli to technological innovation and to more environmentally benign land use. Also, regulations may protect environments by limiting certain production activities and land uses.

The principal policy issues to be addressed by the LUC project include the proper valuation of land resources, food security, sustainable agricultural development, and environmental protection. The region of Northern Eurasia, as defined for this project, represents a critical mass both for analyzing regional driving forces of global processes and for analyzing regional implications of global processes when addressing these policy issues. Major imbalances in the food production and supply systems of the study region might lead to significant direct impacts via the market mechanism and to important secondary impacts through modified resource use and land degradation patterns, e.g., accelerated deforestation in other world regions.

### **3.3 The role of technology**

As late as last century, almost all of the increases in world food production were obtained by bringing new land into production. By the end of this century, almost all of the necessary increase in world food production will have to come from higher yields (Ruttan and Hayami 1988). This view is confirmed by FAO which estimates that about 80 percent of the production increases in developing countries, between 1990 and 2010, will result from yield increases and intensification of land use (FAO 1995). In developed countries, productivity increases are likely to result in a decline of agricultural areas.

---

<sup>1</sup> When institutions fail to enforce regulations, this may not be entirely true.

Technological progress in crop production has brought about intensification in both space and time. Higher yields per hectare of harvested area have resulted from improved seeds, increased application of fertilizers, better plant protection, and improved tools and mechanization. Cropping intensity has also increased, i.e., the average number of days per year that land is used for crop production has increased due to irrigation and reduced fallow periods.

Technology is used here in the broadest sense of the word to embrace all innovative processes that enable land, in whatever application, to continuously meet all the demands on it, at socially acceptable costs. Such innovations may involve movement along existing production levels by exploiting opportunities for factor substitution (e.g., capital for land and labor), or movement from one production mode to another, with implications for resource-use efficiency and profitability, land-cover attributes and material balances.

In most existing models, the process by which technological change occurs has been treated as being outside the economic system. Several authors suggest that technological change is largely induced within the economic system (see Hayami and Ruttan 1985; Binswanger and Ruttan 1978; Tiffen and Mortimore 1992). For example, pressures from scarcities and environmental constraints are known to drive technological innovation. Given that technological change is an essential part of growth and a major determinant of future land use, it is desirable to introduce the mechanisms of technological progress directly into a model of land-use and land-cover change.

### **3.4 Regional land-use policy issues**

In Western Europe, the single most important driving force for future land-use changes will be the Common Agricultural Policy (CAP) of the European Union (see Kitamura *et al.* 1994). Policies within the CAP are multifaceted, focusing on supply management, environmental sanity, rural incomes, and avoidance of agricultural trade conflicts. In the midst of sharply contradicting interests and arguments (e.g., Folmer *et al.* 1995), it will be important for those who shape the future of CAP to consider the environmental and land-resource implications of the various policy proposals. The LUC project intends to build the essential analytical tools and to create the necessary datasets required for such integrated economic and environmental policy analyses.



In the former centrally planned economies of Russia and Eastern Europe the land-use situation is perhaps even more complex. The policy discussion relates to a number of issues: establishment of an efficient market system, privatization, modernization in agriculture and forestry, contamination of soils and water bodies, and the need for stability of political institutions. Large-scale reprivatization of land is taking place. Responding to urban unemployment, many people are trying to secure their livelihood from farming small plots without any previous experience in agriculture. The near-term result of these processes could be an extremely diverse picture of ownership patterns of land, machinery and other fixed assets, as well as of farm-management experience. Left unguarded, a series of bankruptcy and ownership concentration cycles may characterize the medium-term development. However, the overall process of economic transition and the agricultural policies of governments in these countries could make a major difference in their pace and direction. Results of the LUC project are expected to provide useful tools and analytical results for governments of countries in Eastern Europe and the former Soviet Union to formulate their land-use policies.

In the past, Chinese agriculture has been able to support a steadily growing population by step-wise increases in productivity and total output. The most recent jump in the first half of the 1980s was due to the 1979 rural reform. The impressive growth in output, however, carried a heavy environmental price tag. Focal issues are quality and quantity of water supply, soil erosion, deforestation, air pollution and aridification. In addition, initial studies on the potential impacts of climate change on Chinese agriculture (Guang and Zhi-hong 1993; Jin *et al.* 1995) and natural ecosystems (Hulme *et al.* 1992) indicate both serious threats and significant opportunities. The dilemma now faced by Chinese policy-makers is to identify environmentally compatible development paths for Chinese agriculture and, in more general terms, for managing land resources in China. The outputs of the LUC project could contribute to formulating such policies.

This brief discussion shows that any sound effort to project<sup>2</sup> future states of land use and land cover must include the interplay between the supply of and the demand for major agricultural and forestry products, as well as the influence of various policy measures on

---

<sup>2</sup> Note the difference between projection and forecast. A forecast is a scenario whose outcome is considered most likely to occur. A projection is a quantitative assessment based on a number of assumptions, not necessarily the most probable ones from the point of view of their joint occurrence.

these interactions. A decentralized representation of a large number of ‘representative’ agents in the model system seems most appropriate to support the overall objectives of the LUC project. This allows for the inclusion of social and political organization through the implementation of market clearing conditions, national or regional constraints on commodity and resource flows, environmental standards and agreements, and budget constraints. It also allows for a fair amount of flexibility within the model to include geographic, socio-economic or cultural specificities of different regions. In the following sections, we outline a framework that provides for the interplay among prices, supply and demand, government interventions, and resource use.

## 4. Basic concepts of welfare analysis and competitive equilibrium

Various large-scale linear and nonlinear programming models have been used to simulate allocation of land between competing activities in agriculture and forestry, two major economic sectors causing land-cover conversions and modifications. Such models usually assume fixed prices and demands. Of course, when dealing with long-term projections of land use, such assumptions are unreasonable and too restrictive, because interrelations between prices and supply-demand balances change over time and should be considered explicitly. These relationships can be assessed in equilibrium models. The partial equilibrium approach is based on the assumption that demand generated in the economy is only affected by commodity prices and that secondary effects, such as changes in incomes of certain segments of consumers, can be ignored. However, when modeling land use and resource allocation, the generation and distribution of incomes may be critically important to investment and capital accumulation among different regions and hence to the dynamics of the production capacity and resource base. Also, consideration of equity and social welfare require simulation of income generation and distribution. Such concerns are incorporated in the general equilibrium approach.

Since unpredictability and uncertainty create a fundamental complexity in the projection of socio-economic and environmental interactions, a valuable contribution that modeling can provide is the comparative analysis of projected impacts from various policy measures. The modeling framework of the LUC project, which combines welfare analysis and the general equilibrium approach can explicitly represent policy variables as will be illustrated below.

### 4.1 A static competitive equilibrium model

Before discussing dynamic aspects, we will first consider a static competitive equilibrium model. We distinguish a number of commodities, indexed  $k=1,\dots,K$ , including both goods and factors such as various foods, fibers, timber, energy, labor, capital goods, services, etc. It is assumed that each commodity  $k$  is exchanged at a single price  $p_k$ . Not all the commodities may be traded nationally or internationally. Demand is generated by a finite number of consumers, indexed  $i=1,\dots,I$ . In the model, there is also a finite number of producers,  $j=1,\dots,J$ .

At a given vector of prices  $p = (p_1, \dots, p_K)$ , let  $y_j(p) = (y_{j1}(p), \dots, y_{jK}(p))$  denote the net production of producer  $j$ , where outputs of the production activity are denoted by positive elements of  $y_j(p)$  and inputs by negative ones. Consumers own commodity endowments  $w_i$ , which they may offer for exchange, and at given prices  $p$ , they demand commodity bundles  $x_i(p) = (x_{i1}(p), \dots, x_{iK}(p))$ . Then, an excess demand vector  $z$  is defined by

$$z(p) = \sum_i x_i(p) - \sum_j y_j(p) - \sum_i w_i \quad (4.1)$$

and a natural solution concept is to require that prices will be adjusted until no commodity is in excess demand, i.e.,  $z(p) \leq 0$ . Each producer  $j$  operates within specific technology options, which can be represented by a set of possible (i.e., feasible) production plans  $Y_j$ . The competitive equilibrium model assumes that producers choose production levels  $y_j$  that maximize their profit  $\pi_j$ , defined as<sup>3</sup>

$$\pi_j = \langle p, y_j \rangle = \sum_k p_k y_{jk} \quad (4.2)$$

and

$$\Pi_j(p) = \max_y \{ \langle p, y_j \rangle \mid y_j \in Y_j \} \quad (4.3)$$

is the resulting maximum profit function. One could introduce various other rules to select a feasible solution from  $Y_j$ , but then a meaningful evaluation of the resulting performance would be difficult and questionable. Profit maximization provides a well defined ‘best case’ perspective.

The choice of consumption bundles that can be made by consumer  $i=1, \dots, I$  is restricted by a budget constraint: consumer  $i$  cannot spend more than what is his<sup>4</sup> income  $h_i$ . His income  $h_i$  consists of two elements: the proceeds  $\langle p, w_i \rangle$  of selling the endowments  $w_i$  and his share in profit  $\Pi_j$ . It is assumed that consumer  $i$  owns a non-negative share  $\theta_{ij}$  in firm  $j$  and that he receives dividends  $\theta_{ij} \Pi_j(p)$ . Furthermore, we assume that  $\sum_i \theta_{ij} = 1$ , for all  $j=1, \dots, J$ , i.e., profits of all firms are fully distributed. Consumer preferences are

---

<sup>3</sup> By  $\langle p, y \rangle$  we denote the inner product of the two vectors  $p$  and  $y$ :  $\langle p, y \rangle = \sum_k p_k y_k$ .

<sup>4</sup> For the sake of simplicity we will not use both forms of gender - his/her - in the description.

expressed by means of a utility function  $u_i(x_i)$ <sup>5</sup>. For a given price vector  $p$  and income  $h_i$ , each consumer chooses a consumption bundle  $x_i(p, h_i)$  so as to maximize his utility  $u_i(x_i)$  subject to a budget constraint  $h_i$ :

$$\begin{aligned} \max_{x_i} u_i(x_i) \\ x_i \geq 0 \\ \langle p, x_i \rangle \leq h_i. \end{aligned} \tag{4.4}$$

The consumers and producers are linked, because income is defined by

$$h_i = \langle p, w_i \rangle + \sum_j \theta_{ij} \langle p, y_j \rangle, \tag{4.5}$$

and because an equilibrium occurs at a price vector  $p^* \geq 0, p^* \neq 0$ , when markets clear,

$$z(p^*) = \sum_i x_i(p^*, h_i(p^*)) - \sum_j y_j(p^*) - \sum_i w_i \leq 0. \tag{4.6}$$

According to this model, agents acting as in (4.3) and (4.4), only react to price signals  $p$ , and the conditions on excess demand (4.6) are satisfied at equilibrium. For applied modeling, it is important to realize that the vector of equilibrium prices  $p^*$  may not be unique. However, under suitable regularity conditions, it is possible to ensure that the number of solutions is finite and thus locally unique. Each of these solutions is Pareto-efficient. This means that it is impossible to find other feasible consumption bundles and production plans that make any actor better off without making at least one other actor worse off. In other words, multiple equilibrium solutions do not dominate each other.

## 4.2 Welfare programs and competitive equilibrium

There are important relationships among models of competitive equilibrium, the concept of Pareto-efficiency and optimal welfare programs. For a given vector of welfare weights,  $\alpha = (\alpha_1, \dots, \alpha_I) \geq 0, \sum_i \alpha_i = 1$ , consider the following welfare program:

$$\begin{aligned} W(\alpha) = \max_{x, y} \sum_i \alpha_i u_i(x_i) \\ x_i \geq 0, y_j \in Y_j \end{aligned}$$

subject to commodity balance equations, (4.7)

---

<sup>5</sup> Consumer behavior could possibly be described by various other rules; but again, the assumption of utility maximization provides for an idealized, yet well-defined behavior. Through the choice of appropriate utility functions, a wide range of demand behavior can be depicted.

$$\sum_i x_i - \sum_j y_j \leq \sum_i w_i \quad (\text{shadow price } p).$$

We note that the solution of such a welfare program is meaningful without any specific assumptions on the specification of utility functions or production sets. In the general case, however, a central coordination of agents may be required to achieve the welfare maximum. When meeting some additional properties, the welfare program can be decentralized and the solution be calculated by competitive equilibrium. Assume that the production set  $Y_j$  allows for inaction, i.e.,  $0 \in Y_j$ , and is compact and convex. Furthermore, assume that the utility functions  $u_i$  are continuous, concave, increasing, and that  $u_i(0) = 0$  and  $\sum_i w_i > 0$ . Then, according to the Second Welfare Theorem (for instance, see Gunning and Keyzer 1995), for every vector of welfare weights  $\alpha$  there exists a corresponding vector of transfers among consumers,  $b_i$ , with  $\sum_i b_i = 0$ , such that an optimal solution of the welfare program, say  $x^*$  and  $y^*$ , is equivalent to a competitive equilibrium with transfers  $b_i$  among consumers. With transfers, incomes, and hence budget constraints, are modified to:

$$h_i = \langle p, w_i \rangle + \sum_j \theta_{ij} \langle p, y_j \rangle + b_i, \quad i = 1, \dots, I. \quad (4.8)$$

In this way, a competitive equilibrium with transfers can account for equity considerations and is Pareto-efficient at the same time. The transfers between consumers are also referred to as lump-sum subsidies (when positive) or lump-sum taxes (when negative). Also, any competitive equilibrium without transfers is Pareto-efficient and corresponds to a choice of welfare weights  $\alpha > 0$  such that  $b_i = 0, i = 1, \dots, I$ .

When demand is described at an aggregate, say national, level without specifying income distribution, the equilibrium model is reduced to the single consumer case as is often assumed in applied models. Then, if there is only one consumer, the optimum of a convex welfare program is a competitive equilibrium solution (since transfers are necessarily zero), and computing an equilibrium solution is achieved by analyzing and solving a convex optimization problem.

This brief discussion shows that for given ownership of endowments and for fixed shares in firms, a competitive equilibrium without transfers will be Pareto-efficient but may be considered unacceptable from an equity perspective. A competitive equilibrium

with transfers accounts for equity considerations without losing efficiency. Furthermore, let us notice that the Pareto-optimal outcomes of welfare maximization and competitive equilibrium models suggest that these concepts are socially desirable. Even if individual producers become sufficiently powerful to affect prices, they would not be able to improve upon the Pareto-optimal outcome of a competitive equilibrium (albeit they will most likely improve their own welfare). Of course, multiple Pareto-optimal outcomes will in general be different in various respects, for example, equity considerations. Welfare analysis aims at the consideration of such issues.

### **4.3 Incorporating policy measures in welfare programs**

Traditionally, general equilibrium models have dealt with cases where all commodities, goods and factors, are exchanged on competitive markets. Of course, this assumption is not always valid, especially when considering environmental resources. In this case we must include a central agency in the model, for instance government, responsible for optimally setting levels of taxes, subsidies, norms (e.g., environmental standards and regulations) and other policy measures. From a formal point of view this case can again be treated within the general equilibrium framework. The government can be considered as an additional actor: it may own endowments and receives income from taxes and tariffs. It may own firms, but these firms should operate like private firms (i.e., be profit maximizing), not as price-setters. The government has the authority to impose taxes, provide subsidies and administrate lump-sum transfers. The government uses its income to finance public consumption and investment, and to redistribute the proceeds from taxation among producers and consumers. Let the consumption bundle of the government be denoted by  $x_g$  and let the preferences of the government be described by a utility function  $u_g(x_g)$ . Like other actors, government maximizes its objective function subject to a budget constraint.

Let us now consider some possible government policies. For example, when considering a commodity tax (or subsidy) at rate  $\tau_k$ , the consumer price  $p_k^c$  of commodity  $k$  is related to the clearing price  $p_k$ , i.e., to the variable associated with the market clearing conditions, according to:

$$p_k^c = (1 + \tau_k) p_k \tag{4.9}$$

where the rate  $\tau_k$  is positive for a tax and negative in case of subsidies. The budget constraint of consumer  $i$  thus reads:

$$\sum_k (1 + \tau_k) p_k x_{ik} \leq h_i \quad (4.10)$$

where income  $h_i$  is defined as in (4.8).

Of course, taxes can also be made consumer or producer specific, e.g., to assist a specific group of producers such as farmers. In practice, various measures like taxes, subsidies and quotas have been introduced by governments to support specific groups of agents by means of price supports rather than by direct income transfers, or to protect particular activities, say growing of rice, from the effects of international competition. Taxes and subsidies, in general, discourage or promote the production and use of specific commodities. Governments use the proceeds of taxes,  $T = \sum_k \tau_k p_k \sum_i x_{ik}$ , to finance public consumption  $x_p$ , price subsidies (when  $\tau_k < 0$ ), and lump-sum transfers  $b_i$ . Tax-ridden prices  $p^c$  can also be generated directly by a welfare program (e.g., see Ginsburgh and Keyzer (forthcoming), Fischer *et al.* 1988):

$$W(\alpha) = \max_{x,y} \sum_i \alpha_i u_i(x_i) - \langle \xi, x \rangle$$

$$x, \xi \geq 0, \quad x_i \geq 0, \quad i = 1, \dots, I, \quad y_j \in Y_j, \quad j = 1, \dots, J$$

subject to (4.11)

$$x - \sum_j y_j \leq \sum_i w_i \quad (\text{shadow price } p)$$

$$x \geq \sum_i x_i \quad (\text{shadow price } p^c)$$

where we define a vector of nominal taxes,  $\xi = (\xi_1, \dots, \xi_K)$ , by a feedback relationship, so as to obtain in equilibrium taxes  $\xi_k = \tau_k p_k$ , where  $\tau_k$  is fixed. Then, the welfare weights  $\alpha_i$  are set in such a way that every consumer, private or public, meets his budget constraint:

$$\langle p^c, x_i \rangle \leq \langle p, w_i \rangle + \sum_j \theta_{ij} \Pi_j(p) + b_i, \quad i = 1, \dots, I,$$

$$T = \sum_i b_i = \langle \xi, \sum_i x_i \rangle.$$

Any equilibrium solution with taxes will be optimal for the welfare program. Note that indirect taxes on producers can be treated in the same way. However, from (4.11) it is



clear that any such taxes and subsidies will hamper efficiency of resource allocation and thus reduce welfare.

#### 4.4 Including trade in the welfare program

So far we have dealt with a closed economy, now we will extend the model formulation to include trade. The possibility to exchange commodities with the ‘outside world’ can be modeled in the following way: Let ‘imports’ and ‘exports’ be denoted by vectors  $z_+$  and  $z_-$ , respectively, and let  $p_+$  and  $p_-$  represent given import and export prices,  $p_+ \geq p_- \geq 0$ . Then the welfare program is formulated as,

$$W(\alpha) = \max_{x,y,z} \sum_i \alpha_i u_i(x_i)$$

$$x_i \geq 0, y_j \in Y_j, z_+ \geq 0, z_- \geq 0$$

subject to (4.12)

$$\sum_i x_i - \sum_j y_j - z_+ + z_- \leq \sum_i w_i \quad (\text{shadow price } p)$$

$$p_+ z_+ - p_- z_- \leq 0 \quad (\text{shadow price } \lambda)$$

where weights  $\alpha_i$  are set to ensure that the budget constraints of agents are met. This formulation can be made more general, allowing for a non-zero trade balance  $\kappa$ , and for nominal tariffs on imports and taxes on exports,  $\xi_+$  and  $\xi_-$ , such that,

$$\xi_+ = \tau_+ p_+$$

$$\xi_- = \tau_- p_-$$
(4.13)

where  $\tau_+$ ,  $\tau_-$  are fixed rates, and where trade is constrained by:

$$0 \leq \tilde{z}_+ \leq z_+ \leq \hat{z}_+$$

$$0 \leq \tilde{z}_- \leq z_- \leq \hat{z}_-$$
(4.14)

Then, the objective function in (4.12) is modified to account for tariffs, and the welfare program is written accordingly:

$$W(\alpha) = \max_{x,y,z} \sum_i \alpha_i u_i(x_i) - \xi_+ z_+ - \xi_- z_-$$

$$x_i \geq 0, y_j \in Y_j, z_+ \geq 0, z_- \geq 0$$

subject to (4.15)

$$\sum_i x_i - \sum_j y_j - z_+ + z_- \leq \sum_i w_i \quad (\text{shadow price } p)$$

$$p_+z_+ - p_-z_- \leq \kappa \quad (\text{shadow price } \lambda)$$

$$0 \leq \check{z}_+ \leq z_+ \leq \hat{z}_+$$

$$0 \leq \check{z}_- \leq z_- \leq \hat{z}_-$$

Obviously, budget constraints of consumers must be modified to include transfers:

$$h_i = pw_i + \sum_j \theta_{ij} y_j + T_{ij}$$

and

$$T = \sum_i T_{ij} = \kappa + \xi_+ z_+ + \xi_- z_-$$

In this case it is also required to specify a ‘tax’ function, i.e., how tariff income and net flow from abroad will be distributed (for  $T > 0$ ) or financed by the consumers (for  $T < 0$ ).

#### 4.5 *Non-rival consumption*

The competitive equilibrium model, as discussed so far, is defined in terms of commodities that directly give utility to a particular consumer or that enter as inputs in the production process. In the case of non-rival goods<sup>6</sup>, as is typical for many environmental resources and services, e.g., fresh air, public demand  $x_g$  affects the utilities of many consumers, i.e.,  $u_i(x_i, x_g)$ , so that the optimal level of  $x_g$  should be chosen collectively. Again, the study of a corresponding welfare program allows to decentralize decisions through specific economic signals, Lagrange multipliers of the optimization problem known as Lindahl prices (e.g., see Gunning and Keyzer 1995). Since these economic signals will be derived from welfare maximization, the resulting equilibrium is Pareto-efficient and provides variables that decentralize the optimal choice of  $x_g$  to the decisions of the individual agents. The derivation of Lindahl prices may be viewed as an idealized political process. Yet, as is the case with the process of market clearing in the standard competitive equilibrium, the process of reaching agreement on public consumption and clearing prices is left unspecified by the computation of Lindhal prices.

---

<sup>6</sup> Non-rival consumption means that goods benefit several consumers without being distributed among them. For instance, a beautiful landscape can be admired (i.e. ‘consumed’) by many individuals without loosing its beauty. In contrast, rival goods, such as a loaf of bread, are distributed in the process of consumption and provide utility only to a single consumer.

## **5. Spatial aspects of modeling land-use and land-cover change**

In the economic framework being developed in the LUC project we represent human activity as variations of three types of economic agents: consumers (e.g., rural and urban households), producers (e.g., firms, representative farms, forestry sector enterprises) and government. Of course, the representation of individual consumers and producers is an impossible task; rather, we describe representative 'homogenous' groups of consumers and producers, termed agents of the model. As will be elaborated later on, a 'consumer' may be a segment of the population, a social class, national or local governments, an international agency, or a foreign economic agent with demand for export commodities. Consumers can be differentiated with regard to geographic location, level and source of income, habits, and value system. Differentiation into income strata is relevant to analyzing social impacts, for instance of poverty and hunger, and hence of economic hardship which may lead to exploitation of marginal areas and environmental degradation.

Classes of consumers represent specific segments of the population and are characterized in terms of their preferences and budgets. At minimum, rural and urban households in each geographical unit will be distinguished in the LUC model, and perhaps be organized into different income strata. Consumer preferences will be expressed through demand systems using nested expenditure categories (see Section 9, Table 9.1), with broad commodity groups at the highest level, including foods, wood products, energy, industrial goods, housing, services, and recreation. Expenditure categories with a strong link to land use must be further subdivided. For instance, in the food category we distinguish consumption of different crop commodities (cereals, root crops, vegetable oils, etc.) and livestock products (meat and milk).

Similarly, producers are grouped according to distinguishing characteristics, such as sector of the economy, level of management and technology, or kind and adequacy of resource endowment.

### **5.1 Defining the spatial representation**

A model for studying land-use and land-cover changes must be geographically explicit. The geographical representation should allow for sufficient differentiation of

geobio-physical determinants of land productivity, and hence of land use, such as climatic conditions, soil characteristics, and landform (i.e., physiography, relief intensity, slope, aspect). Representation of social, economic and political organization, e.g., national and regional administrative boundaries, is essential as well. To reflect, yet structure, the wide range of heterogeneity of the real-world system it is helpful to consider the concept of compartments in the LUC model.

The approach we adopt is based on subdividing the study region into compartments, i.e. sub-regions. Actors and processes in each compartment ideally are to be represented by a stochastic and dynamic model of the kind discussed in the later sections of this paper. Depending on scale, a compartment may correspond to a collection of farms, to a watershed, a zone within a country, or a group of provinces. Compartments are defined to reflect structured entities, i.e., sub-systems, of the broader region under consideration and their economic and other interactions. Since the kind and degree of organization of social and economic systems may change over time, as may the biogeophysical properties of land, the specification of compartments must avoid being geographically static. In applied studies such as the LUC project, modeling is usually accomplished on the basis of spatial data sets organized on rectangular grids. Compartments are defined as collections of grid cells, and can possibly vary over time. The basic level of spatial organization is thus the grid cell. Note that areas not subject to direct human forcing, e.g., wilderness areas, form separate compartments with land cover derived from simulated trajectories of natural vegetation<sup>7</sup>.

The notion of a compartment, as used here, does not exclude internal heterogeneity of certain characteristics, such as soil or landform; a compartment may itself be subdivided into smaller homogenous land management units to form the basis for a meaningful biogeophysical evaluation<sup>8</sup>. For instance, a valley in a mountainous region that

---

<sup>7</sup> These compartments may still impact upon agents of other compartments by providing utility (e.g., recreation, clean air, 'beautiful' landscape) or affecting joint constraints. For instance, if policy regulations demand a certain water quality in the wilderness area, then shadow prices (e.g., of environmental taxes, or of emission permits) in neighboring compartments will be affected when appropriate regional environmental constraints are imposed.

<sup>8</sup> In land evaluation as carried out by FAO and others (e.g., FAO/IIASA 1993), such basic land units have been termed agro-ecological cells. Because of scale of analysis, these cells often cannot be geo-coded precisely but are known (in a statistical sense) to represent a land quality within the geo-referenced map unit, e.g., a map unit of the FAO/UNESCO soil map.

economically depends on forestry, dairy production and tourism may become a compartment even though there is likely to be a large heterogeneity of resources within that compartment, e.g., in terms of steepness of slopes, soil type and even climate zones. Land management units within the compartment should refer to relevant combinations of such heterogeneous attributes. Section 8 discusses the representation of land in more detail.

## **5.2 Organization of spatial units**

Compartments will be organized hierarchically, e.g., provinces, countries, groups of countries with formal economic and political collaboration (e.g., the European Union), broad regions, etc. Since agents in the model are identified at the compartment level, technological, environmental and financial constraints can be specified at various levels of aggregation within the hierarchy. That way, much descriptive realism can be introduced into the model specification. Decision-making can be represented at the appropriate administrative level, and local, national, and international markets can be simulated. Environmental constraints and mechanisms to enforce environmental agreements can be depicted at the relevant spatial and administrative level. Thus, the proposed structure allows for much flexibility in modeling driving forces operating at different spatial and organizational scales.

In practice, compartments will often be derived by superimposing maps of different aspects of the land, e.g., administrative boundaries, social and economic organization, climate zones, landforms, etc., and then drawing boundaries that best reflect the most important distinctions among these map layers. Geographical information systems (GIS) provide powerful assistance in storing and manipulating geo-referenced data. The details of defining and characterizing compartments will, in general, vary with the purpose of a study and the scale of the study area. In the LUC project, several geographic layers for the continental model are being assembled at a scale of 1:4 million. Climate, landform, soil, and vegetation maps form the backbone of the biogeophysical land characterization. The description of compartments and their agents must refer to relevant endowments, applicable economic and physical balance equations (like budget constraints, balance of commodity demand and supply, or consistency of resource use and availability), with identification of 'immobile' resources (e.g., soil, climate) of each compartment and the

'mobile' resources (e.g., labor, capital, minerals, water) which can be redistributed or 'traded'.

In the LUC model, compartments (i.e., their economic agents) interact through commodity trade and financial markets, and flows of mobile resources. They compete for allocation of limited public resources and foreign investment. They are jointly affected by government policies, regulations and other regional constraints. Compartments also interact through material transport and transboundary flows of pollutants. Human migrants, mostly rural to urban migration, may generate demographic flows across compartment boundaries.

### **5.3 Representing commodity and resource flows**

With respect to the interaction of different compartments, due consideration must be given to an adequate representation of the physical flows of commodities in the LUC model system. Two aspects need to be mentioned: (i) transformation of commodities through processing when flowing from the production site, e.g., farm-gate, to the consumer, and (ii) transportation requirements to bridge distance when flowing to markets in different locations. For a tractable implementation, some simplifications are adopted in both respects.

As to the transformation of commodities, one approach to dealing with processing is to represent all levels of processed commodities separately in all markets. This would most likely constitute a large burden to data collection, model specification and parameter estimation. Another approach, recommended here, is to treat processed commodities as consisting of raw materials, produced at farm-gate or forest enterprise, plus a non-agricultural commodity which accounts for processing activities and transportation. When the non-agriculture sector is sufficiently disaggregated in its description, these can be separate inputs. The prices seen by consumers in different markets will therefore consist of a raw material component, a processing margin, transportation margins, and possibly taxes or subsidies, and tariffs. Such an approach has been applied, for instance, in Fischer *et al.* (1988) and Folmer *et al.* (1995).

Transportation requirements, in particular, are critical since the LUC study must give due consideration to comparative advantage among producers resulting from differences in

geographic location. Consumer prices of land-based products, i.e., of most food stuffs and wood products, typically contain only a small raw material component. Therefore, differences in transportation requirements related to different geographic locations will largely determine the viability of export and import strategies. Export cropping will be rather unlikely in remote locations. On the other hand, some land uses which might otherwise not be competitive may become viable or even necessary because of prohibitive transport requirements.

In the most elaborate representation of these aspects, the modeler tries to maintain product heterogeneity with regard to a vector of physical commodity characteristics, location of origin, and location of use. Hence, maize produced in France and used in Russia would be listed as a separate commodity, different from maize produced in Hungary and used in Poland. Such a treatment may be required, for instance, if one wishes to keep track of bilateral trade flows, or of some forms of preferential trade agreements. However, such a treatment of heterogeneity has a dire cost in terms of the number of decision variables generated and the number of commodity balances that must be cleared. For instance, if a model specification deals with only 25 tradable commodities and 20 regions, then in a free routing case, i.e., when all bilateral flows are technically possible and unrestricted, the number of trade flow variables is  $20 \times 19 \times 25 = 9500$ . The situation may improve somewhat with constrained routing. When additional information is available, e.g., indicating technical impossibility or political undesirability of trade, bounds on specific trading activities can be set to reduce the number and limit the volume of bilateral trade flows.

For applied modeling, researchers have developed simplifying assumptions that are geared to overcoming the difficulties of commodity heterogeneity and the associated vast data requirements. Two methods have been widely used and are especially relevant for consideration in the LUC project, the Armington approach and the trade-pool approach.

Following the Armington approach (Armington 1969), the modeler postulates that sectors differentiate among imported commodities according to the country of origin, and among domestic and imported varieties. The Armington structure has been criticized as being unnecessarily restrictive. However, it has been widely used in world trade models, allowing, in a straightforward manner, to combine trade in similar goods with conditions of less-than-perfect import demands (Hertel 1995).

A common approach to reduce the complexity of a full trade matrix and to avoid possible indeterminacy of trade flows is to assume a trade pool into which all exports flow and from which all imports originate. This approach eliminates bilateral trade flows but allows to retain information on transportation costs as well as constraints on routes to and from the pool. Transportation is thus interpreted as a means to homogenize commodities that differ by location only and have identical physical characteristics otherwise (Ginsburgh and Keyzer, forthcoming).

#### **5.4 Implementation of the trade-pool approach**

As a starting point in the LUC modeling effort, we follow the trade-pool approach and distinguish four levels of commodity transformation: raw materials (basic products as obtained at the production site), processed commodities in the local (regional) market, commodities processed and transported to the national level market, and commodities transported to and obtained from the world market. Policy measures and restrictions to commodity flows are conceivable at all of these levels. It is important to ensure that the commodity mapping between levels is kept consistent in both physical and value terms. An illustration of the resulting spatial hierarchy is shown in Figure 5.1 and Figure 5.2.

Let the transformations between different commodity levels be described by matrices  $T^f, T^r, T^n$ , respectively. For instance, mapping  $T^r$  is applied to convert trade flows from national retail level  $z^n$  to regional level  $z^r$ , and mapping  $T^n$  to go from international trade level  $z^{nw}$  to national retail level  $z^n$ . Furthermore, let  $p^f, p^r, p^n$ , and  $p^w$ , denote the respective prices. If only transportation activities are involved, e.g., to convert from national retail level  $z^n$  to the local retail level  $z^r$ , the transformation matrix  $T^r$  has a very specific form. For instance, in the case of four retail commodities, with the third sector providing transportation services of  $t_k^r$ ,  $k = 1, \dots, K$ , units per unit of commodity  $k$  transported, the mapping matrix becomes:

$$T^r = \begin{pmatrix} 0 & 0 & 0 & 0 \\ 0 & 0 & 0 & 0 \\ t_1^r & t_2^r & 0 & t_4^r \\ 0 & 0 & 0 & 0 \end{pmatrix}$$



Then, the following relationships (or similar ones, depending on model specification) between prices and physical quantities must hold for consistency of the mappings:

$$\begin{aligned}
p_-^n &= p_-^w(I - T^n) \\
p_-^r &= p_-^n(I - T^r) && \text{for exported commodities,} \\
p_-^f &= p_-^r(I - T^f)
\end{aligned} \tag{5.4a}$$

and similarly for prices of imported commodities,  $p_+$ ,

$$\begin{aligned}
p_+^n &= p_+^w(I + T^n) \\
p_+^r &= p_+^n(I + T^r) && \text{for imported commodities.} \\
p_+^f &= p_+^r(I + T^f)
\end{aligned} \tag{5.4b}$$

For physical volumes at different levels of the spatial hierarchy we obtain dual relationships for exported and imported commodities,  $z_-$  and  $z_+$ , respectively:

$$\begin{aligned}
z_-^n &= (I - T^n)z_-^{nw} && z_+^n = (I + T^n)z_+^{nw} \\
z_-^r &= (I - T^r)z_-^n && \text{and} && z_+^r = (I + T^r)z_+^n \\
z_-^f &= (I - T^f)z_-^r && z_+^f = (I + T^f)z_+^r
\end{aligned} \tag{5.5}$$

The relationships in (5.5) indicate how commodities must be accounted for at different levels of the spatial hierarchy in order to maintain consistency of physical flows. For instance, import of commodity vector  $z_+^{nw}$  from the global commodity pool will result in a vector  $z_+^n$  to enter the national commodity pool. Note that the  $T$ -mappings in (5.4) and (5.5) could be differentiated according to the direction of trade, i.e., separate mappings for exports and for imports. Figure 5.1 shows in a simplifying way how regional production, denoted by  $q$ , gets transformed to the regional retail level, where it may be used for consumption,  $d$ , or as intermediate production input,  $v$ , or may enter or leave stocks,  $s$ . In the figure, the local commodity pool is linked to the national level by means of a region-specific transformation,  $T_r^{hs}$  ( $h$  referring to country index and  $s$  denoting a region within country  $h$ ), and further to the international market through a country specific mapping,  $T_n^h$ . Figure 5.2 illustrates that in this spatial hierarchy commodity flows can be limited and prices be distorted by policy measures<sup>9</sup>.

---

<sup>9</sup> There may also be reasons of physical infrastructure that limit commodity flows.

Figure 5.1: Physical flow of commodities in LUC Core Model.

# LUC - CORE MODEL SPATIAL HIERARCHY

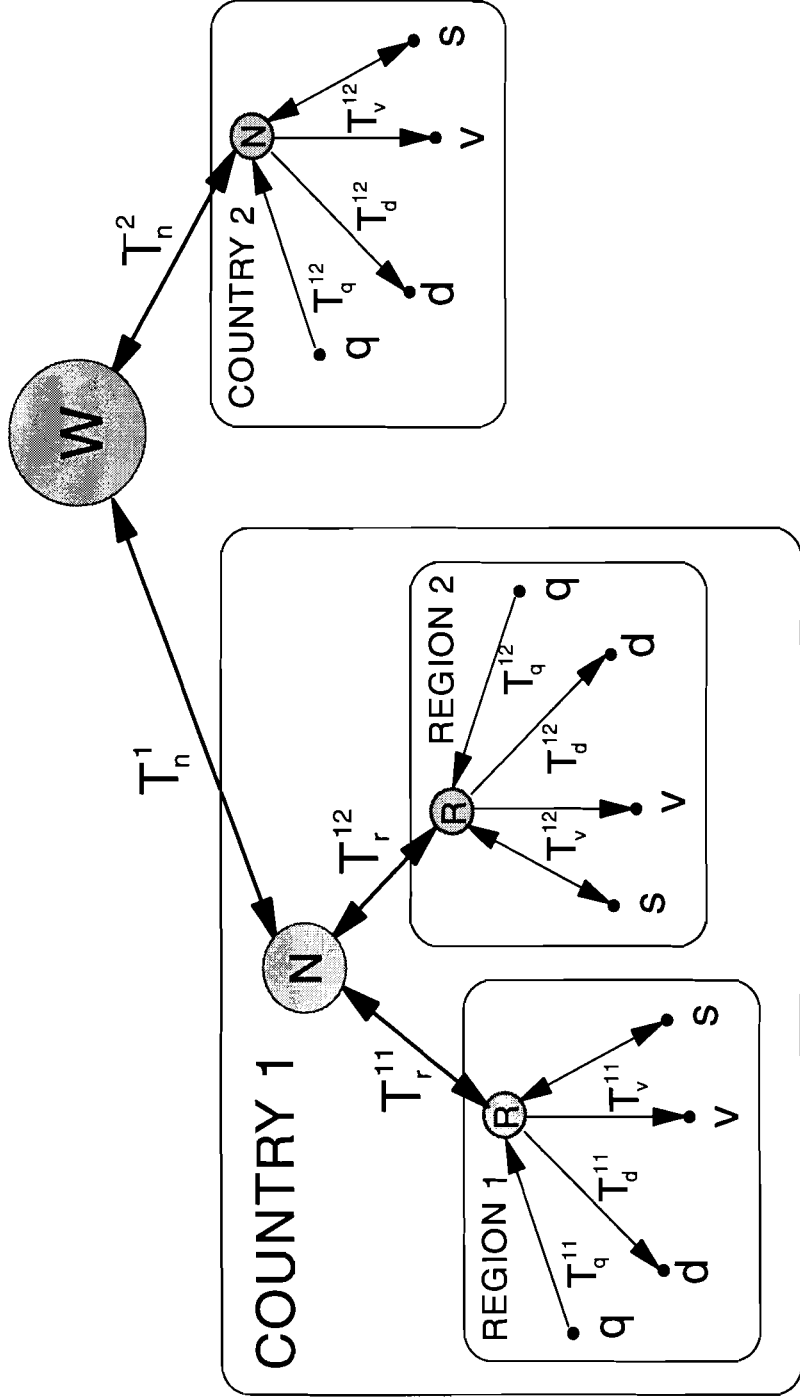
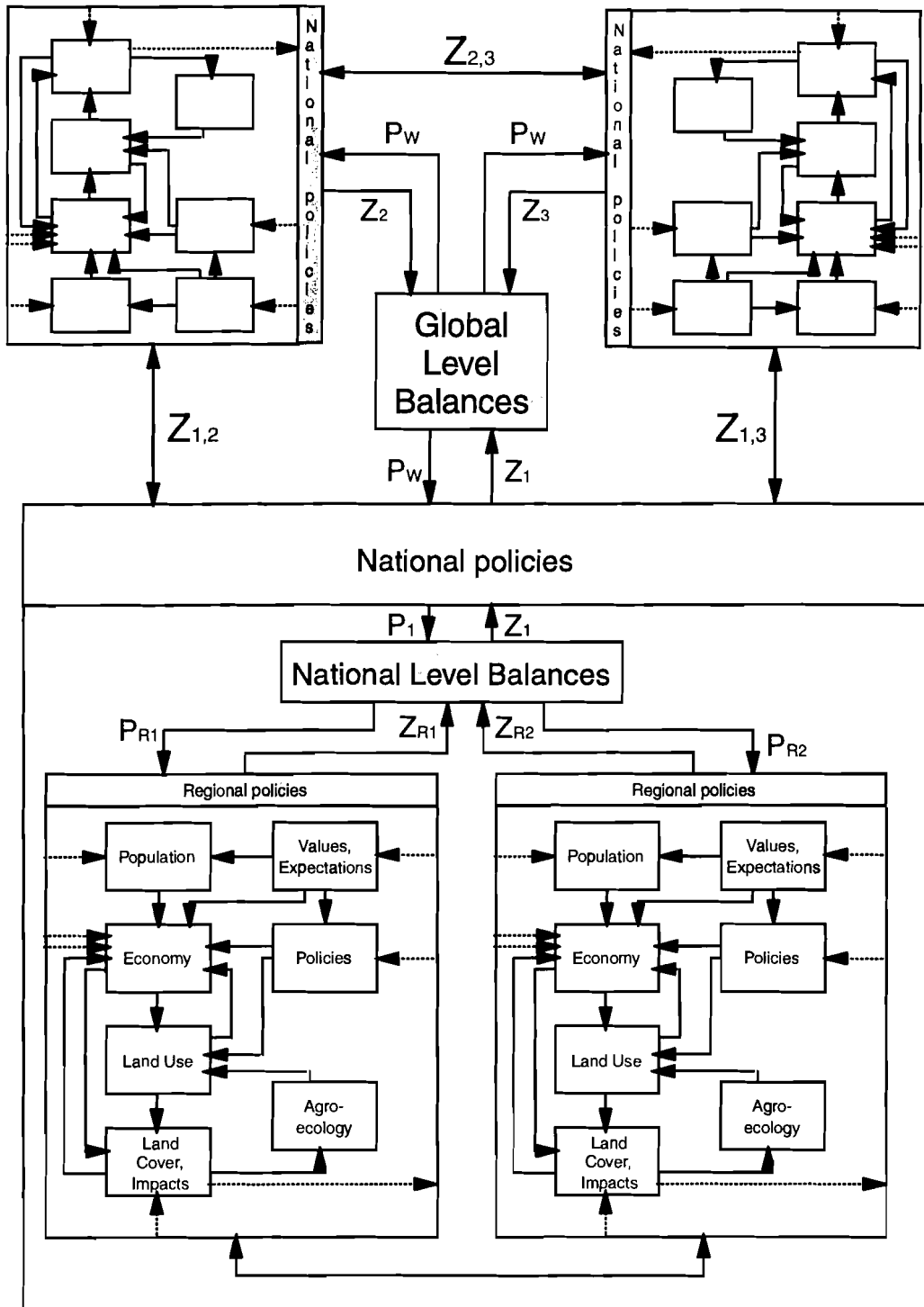

Figure 5.2: Spatial hierarchy in LUC modeling system



## 5.5 Construction of commodity balances

Figure 5.1 and the discussion in Section 5.4 have indicated the flows and processing transformations of commodities, from the production site, e.g., farm or forest enterprise, to the final demand destination. We have also introduced the concepts of market-clearing conditions in Section 4 (e.g., see (4.5)). We can now construct commodity balances, at different levels of the spatial hierarchy, which constitute fundamental relationships in applied general equilibrium models. For this, we recapitulate the variables that enter the commodity balances of each sub-region  $r$ :

$q^r$	vector of production in region $r$ ,
$s_+^r$	sales from stocks,
$s_-^r$	purchases to stocks,
$z_+^r$	imports to sub-region $r$ ,
$z_-^r$	exports from sub-region $r$ ,
$d^r$	final consumption in sub-region $r$ ,
$v^r$	intermediate inputs in sub-region $r$ ,
$i^r$	investment <sup>10</sup> in sub-region $r$ .

Then, commodity balances at sub-regional, national and world level are, respectively, obtained as,

Commodity balance in sub-region:

$$q^r + s_+^r - s_-^r + z_+^r - z_-^r \geq d^r + v^r + i^r \quad (5.6)$$

National commodity balance:

$$q^n + s_+^n - s_-^n + z_+^n - z_-^n \geq d^n + v^n + i^n \quad (5.7)$$

Consistency of trade within country:

$$z_+^n = \sum_{r \in I_n} z_+^{rn}, \quad z_-^n = \sum_{r \in I_n} z_-^{rn}, \quad (5.8)$$

Consistency of global trade:

$$0 = z_+^w = \sum_n z_+^{nw}, \quad 0 = z_-^w = \sum_n z_-^{nw}, \quad (5.9)$$

---

<sup>10</sup>Note that investment (as all other variables) refers to physical commodities, not value terms.

where variables  $z_+^f, z_+^n, z_-^f, z_-^n$  and  $z_+^{nw}, z_+^n, z_-^{nw}, z_-^n$  are related as in (5.5). Furthermore, we may impose specific limits on commodity flows at the country or regional level by requiring that (5.10) holds in addition to (5.6) - (5.9):

$$\begin{aligned} \tilde{z}_+^r &\leq z_+^r \leq \hat{z}_+^r, & \tilde{z}_-^r &\leq z_-^r \leq \hat{z}_-^r \\ \tilde{z}_+^n &\leq z_+^n \leq \hat{z}_+^n, & \tilde{z}_-^n &\leq z_-^n \leq \hat{z}_-^n \end{aligned} \quad (5.10)$$

## 6. Temporal aspects of land-use change

A main task of the LUC project is to study the sensitivity of land-use and land-cover change dynamics to various policies, behavioral assumptions, demographic and socio-economic developments, and to environmental conditions. Hence, dynamics is a critical issue in the modeling effort. The time-span of the analysis covers the period from 1990 to 2050, which is subdivided into 5-year intervals. Thus, the model is of discrete time with thirteen time steps,  $t = 1, \dots, 13$ . The initial step, with  $t = 1$ , refers to year 1990 and the final step,  $t = 13$ , refers to the end of the model horizon, i.e., to the beginning of year 2050.

We turn now to discussing temporal aspects of modeling consumer and producer behavior in the LUC model. For this we discuss the role of model-endogenous and model-exogenous dynamics and introduce intertemporal specifications of consumers' utility function and the producers' profit function. The aim is to describe how variables of interest change over time. There are many factors that may cause such changes. We group them into two sets: factors exogenous to the welfare analysis and factors endogenous in it. For instance, time-dependent exogenous factors include variables such as parameters that describe the shift in technology, e.g., of production functions, changes in characteristics of agents, e.g., changes in life-styles expressed through shifts in parameters and functional forms of the demand system, or changes in policy variables, like trajectories of tax levels. Exogenous dynamic factors are easily implemented, by allowing for time-dependent functions in the model. Their introduction does not lead to any essential methodological complications and can be dealt with effectively by simple extensions of the static framework (see Section 4) by means of recursive dynamic simulation. This involves computing a sequence of single-period equilibrium solutions for periods  $t = 1, 2, \dots$  which are related through the updating of some parameters and exogenous variables.

When dynamics depend on endogenous factors, such as on allocation decisions of consumers (e.g., allocation of income to savings and consumption) and of producers (e.g., decisions on investment and resource use), a static model formulation is clearly insufficient. This section mainly serves the discussion of endogenous dynamics in the LUC model.

## 6.1 Intertemporal welfare analysis

Ideally, intertemporal welfare analysis should start from an infinite time-horizon. Two conceptually different approaches exist to implement infinite-horizon models and to perform such an analysis:

- (i) To deal with a finite number of infinitely lived agents. For example, the initial population of a geographical unit and its descendants can be interpreted in this way. This kind of representation is called dynastic model. The basic mechanism to deal with intertemporal aspects of consumer decisions is to include so-called time-recursive consumer preferences. Each agent's (i.e., each dynasty's) well-being,  $u_i^t$ , in period  $t$ , is described as depending on current consumption,  $x_i^t$ , as well as next period's well-being,  $u_i^{t+1}$ , through:

$$u_i^t = U_i(x_i^t, u_i^{t+1}) \quad t = 1, 2, \dots \quad (6.1)$$

- (ii) To consider an infinite number of generations of finitely-lived agents. Each generation lives (at least) two time periods, e.g., labeled 'young' and 'old'. Also, generations overlap, i.e., the 'old' of generation one live together with the 'young' of generation two, etc. Because of this feature, such models are termed overlapping generations models.

Various specifications of both types of models are discussed in Gunning and Keyzer (1995) and Ginsburgh and Keyzer (forthcoming). In the LUC project, we start from the dynastic model specification. It is generally impossible to solve numerically a model with an infinite number of unknown variables or equations, as occur in infinite-horizon dynastic and overlapping generations models. Infinite-horizon models and the proposed solution techniques suffer also from various other theoretical and practical problems (e.g., as discussed in Gunning and Keyzer 1995). Therefore, in the LUC project we aim to implement a finite-horizon approximation of the infinite problem.

## 6.2 T-period general equilibrium models

A competitive general equilibrium setup where agents decide on current and future periods over a finite time horizon,  $t = 1, \dots, T$ , is referred to as T-period competitive equilibrium. A critical disadvantage of finite horizon models is that the state of the system

beyond period  $T$  is irrelevant to the decisions of the agents unless some valuation is introduced through imposing appropriate terminal conditions in the model. Let  $\{\hat{x}_i^t\}$  denote an optimal trajectory of consumption by the  $i$ -th consumer and  $\{\hat{y}_j^t\}$  be optimal net supply from the  $j$ -th producer. Excess demand at time  $t$  is defined as,

$$z^t = \sum_i \hat{x}_i^t - \sum_j \hat{y}_j^t - \sum_i w_i^t \quad t = 1, 2, \dots, T$$

The allocation  $\hat{x}_i^t, \hat{y}_j^t$  supported by the price vector  $\hat{p}^t \geq 0, \hat{p}^t \neq 0$  is a  $T$ -period competitive equilibrium solution if the following conditions are satisfied:

- (a) Producers and consumers react to prices only, without trying to affect them, i.e., they are price-takers;
- (b) Consumers are limited by a budget constraint,  $h_i^t$ , consisting of the following parts: the proceeds  $\langle \hat{p}^t, w_i^t \rangle$  of exchanging endowments  $w_i^t$ , and distributed profits. It is assumed that consumer  $i$  owns a non-negative share  $\theta_{ij}^t \geq 0$  in firm  $j$ , such that  $\sum_i \theta_{ij}^t = 1$ , for all  $j = 1, \dots, J$ , and that he receives respective dividends  $\theta_{ij}^t \langle \hat{p}^t, \hat{y}_j^t \rangle$  from this firm. In addition, we assume that consumer  $i$  associates with each trajectory of consumption bundles  $\{x_i^t\}$  a utility level  $u_i(x_i^1, \dots, x_i^T)$  and chooses  $\{\hat{x}_i^t\}$  so as to maximize utility  $u_i^t(x_i^t)$  subject to a feasibility constraint  $x_i^t \geq 0$  and subject to his budget  $h_i^t$ .
- (c) Each producer  $j$  operates with a technology defining the set of feasible production plans  $Y_j^t$ . Producers maximize the sum of discounted profits. The technology set of producers, production levels, and accumulation of resource stocks are represented by agent-specific transformation constraints:

$$\begin{aligned} g_j^t(t, y_j^t, k_j^t, k_j^{t+1}) &\leq 0 \\ y_j^t &\in Y_j^t, \quad t = 1, \dots, T \\ k_j^t &\geq 0, \quad t = 1, \dots, T+1 \end{aligned} \tag{6.2}$$

where technological relationships, environmental constraints and transformation of the resource stocks are described by functions  $g_j^t(\cdot)$ . Vector  $y_j^t$  denotes the net



supply of commodities to the market,  $k_j^t$  is the stock of resources (including capital, labor, land, etc.). Vector  $k_j^{t+1}$  is the stock of resources that, given  $y_j^t$  and  $k_j^t$ , will be made available in period  $t+1$ . Some of the components of the stock of resources will be produced in period  $t$  or may use inputs of stock  $k_j^t$ , others may grow or deplete at a natural rate or be generated by production processes.

There may also be joint constraints on total outputs from all producers  $j = 1, \dots, J$ , e.g., on total emissions of  $\text{CO}_2$ , or on deposition of  $\text{SO}_2$  at a given receptor. Note that such constraints may be decentralized through implementation of ‘production’ permits, possibly tradable permits that can be exchanged between producers.

When dealing with a finite number of time periods  $T$ , it is critical to include appropriate terminal conditions. These may significantly affect the trajectories of allocations until period  $T$ .

(d) Markets are in equilibrium for all periods  $t = 1, \dots, T$ :

$$\begin{aligned} \sum_i \hat{x}_i^t - \sum_j \hat{y}_j^t - \sum_i w_i^t &\leq 0, \\ \langle \hat{p}^t, \sum_i \hat{x}_i^t - \sum_j \hat{y}_j^t - \sum_i w_i^t \rangle &= 0, \\ \hat{p}^t &\geq 0, \quad \hat{p}^t \neq 0 \end{aligned} \tag{6.3}$$

An important aspect of T-period competitive equilibrium models is intertemporal Pareto-efficiency, i.e., they generate trajectories of allocations such that no agent can be made better off without somebody else losing. As discussed in Section 4 for static models, an equivalent intertemporal welfare program can be formulated as maximization of:

$$\begin{aligned} \max_{x,y} \sum_i \alpha_i u_i(x_i^1, \dots, x_i^T) \\ x_i^t \geq 0, \quad y_j^t \in Y_j^t \end{aligned}$$

subject to constraints for periods  $t = 1, \dots, T$ : (6.4)

$$\begin{aligned} \sum_i x_i^t - \sum_j y_j^t - \sum_i w_i^t &\leq 0 \\ g_j^t(t, y_j^t, k_j^t, k_j^{t+1}) &\leq 0 \\ k_j^t &\geq 0, \quad t = 1, \dots, T+1. \end{aligned}$$

Taxes and international trade can easily be incorporated within this dynamic model, trade balances can be written as an intertemporal constraint:

$$\sum_t (\langle p_t^-, z_t^- \rangle - \langle p_t^+, z_t^+ \rangle) \leq \kappa \quad (6.5)$$

where  $\kappa$  is the overall trade deficit of a compartment, and other trade-related variables are defined as in previous sections. Furthermore, the trade balance can also be written in the form of a sequence of constraints rather than as an aggregate constraint:

$$\langle p_t^-, z_t^- \rangle - \langle p_t^+, z_t^+ \rangle \leq \kappa^t, \quad t = 1, \dots, T \quad (6.6)$$

where  $\kappa^t$  is the deficit in any particular period  $t$ , possibly with an additional requirement, equivalent to (6.5):

$$\sum_t \kappa^t \leq \kappa. \quad (6.7)$$

Example 6.1: Let us consider two simple examples of actor-based intertemporal decision plans. For instance, using the notation of the previous sections, we can describe a smallholder subsistence agricultural system by an intertemporal maximization problem:

$$\begin{aligned} & \max_{y,x} u(x^1, \dots, x^T) \\ & x_t \leq y_t \\ & g(t, y^t, k^t, k^{t+1}) \leq 0 \\ & x^t \geq 0, \quad t = 1, \dots, T \\ & k^t \geq 0, \quad t = 1, \dots, T+1 \end{aligned} \quad (6.8)$$

where  $u(\cdot)$  denotes the utility function of the farm household,  $y$  is net farm output,  $x$  is a vector of final consumption, and  $k$  refers to the quality and quantity of resource stocks. In this specification, the subsistence household is assumed to maximize discounted utility over the entire period,  $t = 1, \dots, T$ . Consumption is determined by net farm output, i.e., production less intermediate consumption (seed, feed, waste). Production  $y^t$  is constrained by the available technology and resource endowment  $k^t$  and the need to maintain resources  $k^{t+1}$ , as specified in transformation function  $g(\cdot)$ . Note that in this formulation the optimal decision of the farm household is independent of markets and government-imposed financial measures, such as taxes or price subsidies. Government can influence optimal decisions under subsistence farming only if it is able to affect the technology set or to

interfere in the dynamics of resource accumulation, i.e. the trajectory of vector  $k^t$ . In the model sketched above this means either public investment directed to compartments featuring subsistence farming, or manipulating the technology set.

In contrast, a commercial farm household can be described<sup>11</sup> as a utility-maximizing consumer obtaining income as a profit-maximizing producer (i.e.,  $\theta_{ij} = 1$ , for respective subscripts  $i$  from the set of consumers and  $j$  from the set of producers). Let trajectories of income tax levels  $\{\psi^t\}$ , prices  $\{p^t\}$ , and transfers  $\{b^t\}$ ,  $t = 1, \dots, T$ , be exogenously given; then the optimal program for this farm type can be written as in (6.9) and (6.10):

(a) maximize discounted profit  $\pi$ ,

$$\begin{aligned} \Pi &= \max_y \pi(p^1, \dots, p^T, y^1, \dots, y^T) \\ g(t, y^t, k^t, k^{t+1}) &\leq 0 \\ k^t &\geq 0, \quad t = 1, \dots, T+1 \end{aligned} \tag{6.9}$$

(b) maximize discounted utility  $u$ ,

$$\begin{aligned} \max_x & u(x^1, \dots, x^T) \\ \langle p^t, x^t \rangle &\leq h^t \\ x^t &\geq 0, \quad t = 1, \dots, T \end{aligned} \tag{6.10}$$

where

$$h^t = (1 - \psi^t)(\langle p^t, y^t \rangle + b^t), \quad t = 1, \dots, T$$

In this example, unlike in the case of subsistence farmers, the optimal solution for commercial farm households depends directly on markets and government measures, i.e., prices, including commodity taxes and subsidies, level of income tax, and lump-sum transfers. Note also, that in the presence of joint regional constraints commercial farmers and subsistence farmers will affect each other, for instance, through shadow prices or the level of environmental taxes in equilibrium derived from such constraints.

### 6.3 Specifying an intertemporal utility function

We return to the utility function defined in (6.1). It assumes a special recursive separability, namely that intertemporal utility can be written in a nested form as:

$$u_i(x_i^1, x_i^2, \dots) = U(x_i^1, U(x_i^2, U(x_i^3, \dots, U(x_i^t, u_i^{t+1}(x_i^{t+1}))) \dots))) \tag{6.11}$$

---

<sup>11</sup>To keep notation simple, we ignore credits or sale of assets in the example.

This representation is very practical for implementation as it allows to concentrate on a series of linked single-period sub-problems. A special form of the intertemporal utility function commonly used in applied studies is obtained from (6.11) under the simplifying assumption that the terms of consumers' utility involving current consumption and utility in future periods are separable and linearly related, such that:

$$u_i^t = U(x_i^t, u_i^{t+1}) = f(x_i^t) + \mu_i u_i^{t+1} \quad (6.12)$$

If  $0 < \mu_i < 1$  is constant over time<sup>12</sup>, (6.11) simply becomes

$$u_i(x_i^1, x_i^2, \dots) = \sum_i (\mu_i)^{t-1} f_i(x_i^t) \quad (6.13)$$

This specification assumes that past consumption levels influence future ones only via the budget constraint, and that utility in period  $t$  is not affected by consumption in earlier periods. More complicated forms of the intertemporal utility function can cope with these restrictions.

#### **6.4 Population dynamics**

A third type of dynamics relates to the changing number and composition of agents in the LUC model. We adopt the assumption that the agents in the model fall within homogenous groups. To avoid theoretical problems of indivisibility, we further require these homogenous groups to be relatively large. For instance, we assume the initial population of each geographical unit to form such homogenous groups. Over time, the size of each group is adjusted through two mechanisms: (i) demography of births and deaths, and (ii) transition and migration between groups, e.g., rural to urban, or between geographic units.

This is important, since one fundamental endowment of each group of agents, namely labor, depends on the number of group members. Apart from having their endowments move among locations and social classes, consumers changing group membership will usually also change life-styles and demographic characteristics. When taking group membership into account it is convenient to assume that utility functions are separable over time and by social groups to which an individual may belong, and to define the well-

---

<sup>12</sup> In this case  $\mu$  is usually interpreted as discount factor.

being of each homogenous group  $i$  in terms of per capita utility multiplied by the number of members in each group, i.e.,

$$u_i(x_i^1, x_i^2, \dots, x_i^T) = u_i(n_i^1 u_i^1(x_i^1 / n_i^1), \dots, n_i^T u_i^T(x_i^T / n_i^T)) \quad (6.14)$$

where  $n_i^t$  represents the number of members in group  $i$  in period  $t$ ,  $x_i^t$  is total consumption of group  $i$ , and  $u_i^t(x_i^t / n_i^t)$  denotes utility of an individual in period  $t$  being member of group  $i$ . In the LUC project, we will start by describing demographic transitions and migration, i.e., trajectories of  $n_i^t$ , exogenously<sup>13</sup>. However, the LUC approach is flexible and allows to endogenize group membership later on, for instance, making it dependent on relative wages among sectors of the economy as well as among geographical units.

### **6.5 Recursive dynamic equilibrium models**

When assuming that agents have complete and perfect foresight, the solution of the welfare program provides best-case Pareto-efficient trajectories of future development. Myopic models, e.g., recursive dynamic equilibrium models, are easier to calibrate and solve than T-period optimization models. However, their solution path is driven by expectations and, in general, intertemporal efficiency of allocations is lost. In recursive dynamic equilibrium models<sup>14</sup>, agents use only expectations of future prices instead of prices derived from intertemporal optimization and market clearing. Since there exist infinite possibilities to choose expectations, the meaning and relevance of simulation results from such models can be difficult to evaluate. The expectation functions can depend on past and current prices and other variables, but not on future prices and allocations. Also, consumers are assumed to form expectations on the dividends of future periods. As to equilibrium conditions of recursive dynamic models, it is only required that markets in current period  $t$  are cleared.

When building applied models they are often used for scenario analysis. Usually a reference solution is computed; then some parameters or exogenous assumptions are changed, a new solution is calculated and this is compared with the reference solution.

---

<sup>13</sup>Note that this will still affect inter-temporal allocations and efficiency. Thus, it cannot be dealt with in a recursive dynamic structure.

<sup>14</sup>An example of an applied recursive dynamic equilibrium model is IIASA's Basic Linked System (see Fischer *et al.* 1988).

Such comparative analysis, of course, can use various types of dynamic equilibrium models, both T-period and recursive dynamic.

### **6.6. The welfare approach**

The formulation of a welfare program is the conceptual centerpiece of the LUC modeling activity. Therefore, we recapitulate the main features that were elaborated in section 4 and throughout this section. The welfare program is written as an optimization problem that maximizes the weighted sum of the utilities of the participants, i.e., the consumers. There are four types of constraints to be specified in a welfare program:

- (i) The utility constraint which specifies how the utility of a given group  $i$  of consumers in period  $t$  depends on its consumption in that period as well as on its utility in the next period. This is a characterization of the preferences of every group.
- (ii) The transformation constraints describe the set of net supplies in period  $t$  and resources in period  $t+1$  that are feasible at the given level of resources in period  $t$ . This is a characterization of the technology of the economy, i.e., of its capacity to produce commodities by means of produced commodities, labor and natural resources. All the resource dynamics are part of this set of constraints. For example, if there is a given stock of trees in the forest and some are cut and sold, this cutting will together with replanting determine the stock of trees in the next period. If there is no replanting and the cleared land is allocated to agriculture, there will also be a change in the stocks of land: a reduction in the area under forest and an increase in the agricultural land of a particular type. In the LUC project, a substantial part of the data collection and analysis is being devoted to adequately specifying this set of constraints describing the technology and resource dynamics that govern the main land-based sectors of the economy, agriculture and forestry.
- (iii) The commodity balance: for every commodity, the net demand by the consumers cannot exceed the net supply that is feasible in the transformation constraint and from trading.
- (iv) Stock consistency: for every resource, the level used in period  $t+1$  should not exceed the level carried over from period  $t$ .

A welfare program may look like a central plan that would be implemented in a command economy. Clearly, this is not our aim. On the contrary, one of the main advantages of the welfare approach is that it has a clear interpretation as a decentralized model in which every agent can decide for himself. This decentralized model has the following structure:

- (v) Every consumer maximizes his own utility, subject to a budget constraint that spans the time-horizon of the model.
- (vi) Every producer maximizes his own profits, subject to his technology constraint.
- (vii) Commodity markets clear (the equivalent of (iii) of the welfare program above).
- (viii) Resource utilization matches resource availability (as in (iv) above).

Hence, the welfare program defines a standard competitive model, in which the consumers, i.e., in the simplest case the regions in the model, own the commodities and exchange these on markets, at prices that are taken as given by every agent in (v) and (vi) and set so as to ensure that (vii) and (viii) hold. A mathematical description of this model is given in the Appendix. We note that although we use the term ‘competitive’, one may expect that several biophysical relations will possess technical characteristics which rule out decentralization through prices or taxes and will require quantity rationing by a central agency, the government, due to the non-convexity of the relationships. These issues will have to be addressed and decided upon later as experts in the LUC team will submit their proposed specifications on specific issues.

It is important to recall that the welfare program and its decentralized competitive equivalent are normative with respect to the institutions. Private ownership and the existence of all markets is a requirement for decentralization, not necessarily a description of present-day reality in all parts of Eurasia. To derive non-ideal scenarios, distortions will be incorporated in the welfare program and its decentralized counterpart. The realities of present-day economies and societies will be approximated through additional distortion terms in the objective function, e.g., such as discussed in Section 4.3 and 4.4, and through additional sets of constraints.

## **7. Modeling the dynamics of resource stocks**

Studying global change generally involves dealing with long-term phenomena, i.e., projections of economic and natural processes into the second half of the next century. Under such premises the explicit description of resource accumulation processes becomes important, because feedbacks and cumulative impacts (such as soil erosion over an extended period) on the productivity of land could be essential.

### **7.1 *Production activities and resource dynamics***

Modeling production activities relevant to land-use and land-cover change in a way that takes into account both the environmental as well as socio-economic conditions and changes is a challenging and ambitious task. The aim of the production component of the LUC model is to depict spatial and intertemporal allocation of land to various regional activities, such as crop agriculture, livestock grazing, forestry, energy production and mining, settlements and infrastructure, manufacturing, recreation and nature reserves.

The LUC model must allow integration of information from biogeophysical and biogeochemical process models with the economic model. This requires careful selection and definition of compatible variables among the modeling components, as well as appropriate temporal and spatial scales. Emphasis is placed on consistent methods of linking, not merely technical feasibility. This involves far more than bringing various equations into a single computer program.

Land-cover change under near natural conditions (i.e., without significant human influence) can be estimated from modeling vegetation under various projections of biogeochemical processes of the Earth's system, and in particular of the climate system. Although such an estimation is complex by itself and involves partly unresolved scientific issues, it is nevertheless conceptually much simpler than projecting land-cover change managed by human agents. Transformations possible under intensively managed land uses are constrained by natural conditions, but are highly dependent on technological development, economic conditions, and demographic trends. This relates to intensification of production systems within major land-use classes (especially agriculture), and also to conversion of major land uses (e.g., conversion of arable land to non-agricultural purposes). The goal of the supply component of the LUC model is to simulate producer responses under a wide



range of situations and policies. Where possible, historical data and statistical analyses will be used to derive parameter estimates and to validate functional relationships.

The production component of the LUC model includes processes of resource accumulation and degradation, feedbacks and cumulative impacts on land productivity. The term 'resource' is used here in a general sense. Resources include human resources (e.g., with attributes such as population number, distribution, age structure, migration flows, fertility, skill level, etc.), renewable and non-renewable natural resources (e.g., soils, minerals, water, air), biological resources (e.g., biodiversity), and economic resources (e.g., capital stocks and machinery). The model will include both accumulation and degradation processes. The latter encompass physical degradation (e.g., soil erosion, degradation of soil structure, change in level of groundwater table) and chemical degradation (e.g., acidification, salinization, toxification of soils; depletion of the ozone layer; nitrification of groundwater).

The model is solved for a sequence of time periods. Capital and environmental stocks in the current period serve as inputs in the production process. Net supplies of consumer goods and of stock levels at the beginning of the subsequent period are the results of production and investment activities. Hence, environmental resources enter as inputs into production and are, at the same time, affected by these production processes. In this context, pollution is represented as a use of resources, e.g., of clean air. Production activities are specified in terms of quantity and quality of relevant resources. By explicitly dealing with resource accumulation, feedback mechanisms that act slowly on long time-scales (e.g., soil erosion, aquifer depletion) can be represented.

However, the quality of environmental resources not only affects production processes. It also has an effect on the well-being of the population: directly, through health effects of, say a reduction in the ozone layer, or indirectly because consumers may care about the well-being of future generations. We represent such collective dependency on the status of the environment as non-rival consumption. As indicated in Section 4.5, elements of the resource stock representing non-rival goods are not distributed among consumers but many consumers may benefit from them at the same time. For implementation in the model, health effects caused by global change and influenced - positively or negatively - by land-cover change can be treated in two ways. First, they can be included in the utility function of consumers and thus be valued. Secondly, they can be handled by means of

constraints on production, e.g., by enforcing environmental quality standards or by issuing pollution permits. Since the latter is more easy to implement, we will begin in the LUC model with including environmental constraints linked to land-use types (see Section 8), and we will explore the possibility to include some of health effects in the utility function of consumers.

## **7.2 Resource accumulation and degradation**

In the LUC model, commodity supply in each compartment is generated by a number of producers, indexed  $j = 1, \dots, J$ . Production requires various inputs, goods and factors, such as capital  $K_j$ , labor  $L_j$ , energy  $E_j$ , input materials  $M_j$  and sector-specific resources  $A_j$ , e.g., land and water. Both energy and material inputs are aggregates of intermediate goods which in turn may be aggregates of imported and domestic commodities. The outputs also depend on management, like the level of mechanization, or technological progress. The specification of production from land-based sectors of the economy as a function of the extended resource vector  $k_j = (K_j, L_j, E_j, M_j, A_j)$  is a major task of the LUC project. The model should represent present and anticipated practices and conditions in the study region.

There are several methodological difficulties to be resolved. First, biological and biophysical relations that are often represented through complex computer simulation programs, e.g., crop yields derived from dynamic process models, have to be given a more convenient, formal mathematical specification. Secondly, substitution effects between variables that are commonly treated in isolation have to be specified explicitly. Finally, formal estimation methods are needed to quantify and test the validity of the functional relationships in a spatial setting. This requires the application and perhaps a further elaboration of statistical methods, for instance, co-kriging methods.

Producers, e.g., decision-makers of representative farm types, are described as dynamic systems in terms of objectives, natural production conditions (climate, soils, landform), endowments, resource accumulation, and relevant constraints (technology, resources, input use, capital, environment, etc.). In a formal mathematical way, farm pro-

duction options and impacts on resource stocks can be described by a transformation vector-function  $g(\cdot)$ <sup>15</sup>,

$$g(t, y, k^t, k^{t+1}) \leq 0 \quad (7.1)$$

where  $t$  refers to time,  $y$  denotes net output, and  $k$  denotes stocks of resources, such as land types, capital, labor, etc. In practice, vector function  $g(\cdot)$  will be used to specify a set of simultaneous (possibly non-linear) equations and inequalities, to describe a feasible set of production activities. In general, function  $g(\cdot)$  is also affected by uncontrolled, stochastic variables; which are discussed in Section 10.

For instance, the capital stock  $K_j$  of producer  $j$  changes according to investment  $I_j$  and the rate of capital depreciation  $\delta_j$ :

$$K_j^{t+1} = K_j^t + I_j^t - \delta_j K_j^t, \quad t = 1, \dots, T \quad (7.2)$$

where  $K_j^1$  is the initial capital stock. Of course, there may be many ways of choosing input variables (in this example investment  $I_j$ ), such as empirically derived choices or rule-based schemes. However, profit maximization leads to efficiency and can thus provide a reference trajectory of development. In the normative approach, each producer chooses trajectories of inputs,  $L_j^t, E_j^t, M_j^t, A_j^t$  and  $I_j^t$ , so as to maximize discounted profits.

### 7.3 Resource migration

The dynamics of resource accumulation and depletion becomes more complicated in the case of multiple resources and many competing production activities in each compartment. Let us define the vector of available resources in the  $c$ -th compartment of the region,  $c = 1, \dots, C$ , at time  $t$  by  $k_c^t = (K_c^t, L_c^t, E_c^t, M_c^t, A_c^t)$ <sup>16</sup>. In a spatial context it is important to consider also the flow of resources between compartments. Let us denote the outflow (or 'export') of resources from compartment  $c$  to another compartment  $h$  by vector  $r_{ch}^t \geq 0$  and inflow (or 'import') of mobile resources from compartment  $h$  into compartment  $c$  by vector  $r_{hc}^t \geq 0$ . Assume that the flows of resources are constrained to  $r_{ch}^- \leq r_{ch}^t \leq r_{ch}^+$ ; in particular, we may also require that  $r_{ch}^- = r_{ch}^+ = 0$ , in which case no migration of resources

<sup>15</sup>We note that the transformation function, i.e., the description of technology and resource constraints, is agent specific. The subscript denoting agents has been dropped for convenience.

<sup>16</sup>Unless explicitly mentioned, we drop the producer index  $j$  to keep notation simple.

between compartments  $c$  and  $h$  would occur. The total net migration of resources into compartment  $c$  is obtained by summation:

$$R_c^t = \sum_{h=1}^C r_{hc}^t - \sum_{h=1}^C r_{ch}^t \quad (7.3)$$

and thus

$$k_c^{t+1} = k_c^t + R_c^t, \quad k_c^t \geq 0, \quad t = 1, \dots, T \quad (7.4)$$

where  $k_c^1$  is the initial stock of resources in compartment  $c$ . These equations can be used to depict such diverse processes as the flows of capital, labor, or of pollutants.

#### 7.4 Resource conversion

Land conversion within a compartment  $c$  is caused by resource allocation decisions. Let us denote the level of conversions of the  $k$ -th resource to the  $m$ -th resource in compartment  $c$  by  $c_{c,km}^t \geq 0$ . Then total net conversion  $C_{c,m}^t$  into resource  $m$  is obtained as:

$$C_{c,m}^t = \sum_k c_{c,km}^t - \sum_k c_{c,mk}^t, \quad c_{c,km}^- \leq c_{c,km}^t \leq c_{c,km}^+ \quad (7.5)$$

Let us note that the lower and upper bounds  $c_{c,m}^-, c_{c,m}^+$  used in (7.5) provide restrictions on resource conversions. Thus,  $c_{c,m}^- = c_{c,m}^+$  represents fixed levels of conversion; if  $c_{c,m}^+ = 0$ , then no conversion is feasible. This information can be reflected in matrix form, for instance, as is illustrated for land classes in Table 8.1, in the following section of this paper. Defining the vector of resource conversions  $C_c^t = (C_{c,1}^t, C_{c,2}^t, \dots, C_{c,K}^t)$ , resource accumulation processes can be written as:

$$k_c^{t+1} = k_c^t + C_c^t + R_c^t - \delta_c^t k_c^t \quad (7.6)$$

Note that the dynamics of  $k_c^t$  must also take into account depreciation of capital stocks, decay of natural resources, etc.; in the resource accumulation equation (7.6) given above this is indicated by the last term, where  $\delta_c^t$  denotes a vector of depreciation rates.

A feasible allocation  $\Phi_c^t = (\Phi_{ck}^t)$  of resources among a finite number of competing activities, indexed  $k = 1, \dots, K$ , in compartment  $c$  is defined by a set of equations,

$$\sum_k \Phi_{ck}^t \leq k_c^t, \quad c = 1, \dots, C, \quad t = 1, \dots, T \quad (7.7)$$

where  $\Phi_{ck}^t$  is a vector of resources allocated to the  $k$ -th activity. In general, the choice of variables  $r_{ch}^t, c_{c,km}^t, \Phi_{ck}^t \geq 0$  can be modeled in a number of ways. Trajectories could be specified as model assumptions, as part of a scenario framework, or some of the components could be represented as stochastic processes, for instance using Markov chains. In a fully developed normative framework the migration and conversion of resources are deemed decision variables and can be derived from welfare maximization. A critical requirement for this approach is quantitative information on the productivity of each activity  $k$  when carried out by different producers,  $j = 1, \dots, J$ , expressed as a function of respective resource inputs  $k_j = (K_j, L_j, E_j, M_j, A_j)$ .

As mentioned before, such response functions require detailed information such as farm surveys, agronomic experimental data, as well as GIS layers of resource distribution. We realize that a major data collection and estimation effort is required to derive reliable estimates of production functions both for managed as well as unmanaged vegetation. However, detailed classification of land types, of other resources, and of production units is meaningless if the associated production functions cannot depict differences in productivity. Once response functions are available, the model will allow the simulation of responses to a range of policies. For example, we could evaluate the system response to new production alternatives and technologies versus traditional practices. It is also possible to analyze the impacts of certain restrictions on production or their relaxation, or to investigate the consequences of improving infrastructure both within and across compartments.

In summary, land-use models appropriate for the analysis of long-term aspects of global change should account for changes, over time, in the level and quality of environmental resources, socio-economic constraints, and technological conditions. While the dynamics of resource accumulation and degradation call for a multi-period approach, the study of vulnerability, resilience and irreversibility requires a stochastic framework. The latter is discussed in Section 10.

## 8. Representing land resources and land use

The LUC project is particularly concerned with the future of land resources. Therefore, we now extend the considerations discussed in the previous section and elaborate on how land is adequately characterized in the economic model. We also describe how land-use change is tracked in the model and how land-use constraints are implemented to ensure consistency with the resource base.

### 8.1 Describing land resources by site classes

One can think of many diverse attributes by which to characterize land. Care should be taken to differentiate between factors that are intrinsic to land and those that are attached to a particular land use. For instance, soil type is an intrinsic property of a tract of land, whereas fertilizer input is an attribute of land use. To differentiate land resources with regard to land productivity in the LUC model according to physical properties, we define a number of *site classes*,  $a_s$ ,  $s = 1, \dots, S$ , in terms of intrinsic land properties. Attributes that are considered include:

- temperature regime
- moisture regime
- landform and slope
- soil type, soil phase, soil texture, etc.
- land accessibility (e.g., approximated by road density, population density, etc.)

To facilitate the creation of adequate site classes, the LUC project is currently developing several continental-scale databases in a GIS, including climatic variables, vegetation, and land resources. Land characterization is described according to the specifications for global and national soils and terrain digital databases (SOTER) which were recently developed (UNEP/ISSS/ISRIC/FAO 1995) and are gaining wide acceptance. In the SOTER approach, the main differentiating criteria for land characterization are physiography, terrain components and soil components. These criteria '*... are applied in a step-by-step manner, each step leading to a closer identification of the land area under consideration*' (UNEP/ISSS/ISRIC/FAO 1995).

## 8.2 Change in land characteristics over time

Land characteristics, for various reasons, may change over time. Therefore, the concept of site classes must be dynamic and the LUC model will generate consistent trajectories of the extents of different site classes. There are both natural processes and anthropogenic causes that may change the properties of land, and thereby the site class to which a particular tract of land belongs. Let us denote the transfer of land from site class  $s$  to class  $w$  in year  $t$  by  $\Delta a_{sw}^t \geq 0$ . Such a transfer can be caused by:

- Land improvement, e.g., through amelioration and drainage projects, because of irrigation projects, or by terracing. In general, land improvement requires investment, and we indicate the cost per unit of area converted from site class  $s$  to class  $w$ , in period  $t$ , by a cost coefficient  $\gamma_{sw}^t$ .
- Allocation of a site class  $s$  to a particular activity, e.g., land use of type  $h$ , can cause degradation that may eventually lead to a lower site class, for instance, caused by soil erosion.
- Climate change may imply transfer of land to a different site class as it may change, for example, the temperature or soil moisture regime.

Extents of site classes and transfers between site classes must fulfill simple accounting relationships:

$$a_s^t = a_s^{t-1} + \sum_{k \neq s} \Delta a_{ks}^t - \sum_{k \neq s} \Delta a_{sk}^t, \quad s = 1, \dots, S \quad (8.1)$$

$$\Delta a_{ss}^t = 0, \quad s = 1, \dots, S,$$

and the cost of land transfers,  $\Delta C^t$ , is:

$$\Delta C^t = \sum_{s=1}^S \sum_{k=1}^S \gamma_{sk}^t \cdot \Delta a_{sk}^t. \quad (8.2)$$

## 8.3 Defining land-use types and major land-use classes

Land use is best described in a hierarchical, nested way. At the highest level of the hierarchy, we define trajectories of major land uses,  $A_{s,h}^t$ ,  $h = 1, \dots, H$ , in each of the site classes,  $a_s^t$ ,  $s = 1, \dots, S$ . Major land uses are defined by the set {natural/unused, protected, agriculture, grassland, forestry, residence, infrastructure, mining}. Within each of the

major land-use classes, several land uses are described by a list of land-use types. For instance, a nested sequence of describing a particular mode of maize production consists of: agriculture (major land use) - irrigated crop production (land use) - high input, single-crop maize production (land-use type).

The two main processes of land-use/cover change - land conversion and land modification - are then described at different levels of this hierarchy. *Land conversion* is indicated by transferring land in a particular site class  $a_s^t$ , from the  $h$ -th major land-use class,  $A_{s,h}^t$ , to another major land-use class, say the  $l$ -th class  $A_{s,l}^t$ . For example, areas in the natural/unused major land-use class could be transferred to the agriculture class. After that, a land allocation decision within agriculture determines what land-use type to practice on that land, specifying the respective operation sequence and input/output relationships. *Land modification* occurs within major land-use classes and results from changing the allocation of land-use types, be it due to changes in management practices or changes in the crop mix.

In other words, what we propose is twofold. First, to describe land resources in terms of a number of site classes, sufficiently detailed to match these site classes to major land uses. Second, to define land-use types that form the basic objects of analysis and decision-making in the model. These land-use types are described in terms of the relevant economic and physical attributes needed for economic assessment and quantification of land-cover impacts.

Several conditions and consistency relationships must be imposed on any feasible land allocation decision. For discussing examples of such land balance constraints, we define a few additional variables used in describing the basic relationships:

- $A_{s,h}^t$  extent of site class  $s$  in major land use  $h$ , in period  $t$ .
- $\Delta A_{s,hm}^t$  land in site class  $s$  converted in period  $t$  from major land use  $h$  to major land use  $m$ ,  $\Delta A_{s,hm}^t \geq 0$ .
- $AR_{s,k}^{t,\tau}$  establishment (e.g., after harvest or conversion) of land-use type  $k$  in period  $t$  for harvest in period  $\tau \geq t$ , on site class  $s$ .
- $AH_{s,k}^t$  non-destructive harvesting of land-use type  $k$  on site class  $s$ , in period  $t$ .
- $AL_{s,k}^t$  destructive harvesting ('logging') of land-use type  $k$  on site class  $s$ , in period  $t$ .



A few remarks and qualifications may be helpful:

- Conversion of land within a site class, say from the  $h$ -th major land use to the  $m$ -th major land use, variable  $\Delta A_{s,hm}^t$ , may:
  - be restricted by law (e.g., protected areas);
  - be impossible for reasons of the physical environment (for example, hyperarid natural/unused land cannot be converted to rainfed agriculture);
  - require substantial investments (e.g., clearing and leveling of land, etc.).

Therefore, it will be appropriate to define for each site class  $s$ ,  $s = 1, \dots, S$ , a matrix that indicates for each pair of major land uses the feasibility of conversion and indicates the associated investment requirement, as illustrated in Table 8.1. Note that conversion of major land uses within site classes is different from and in addition to transferring land between site classes.

Table 8.1: Example of land conversion options within a site class.

Site class $s$	natural/unused	protected	rainfed agriculture	irrigat. agriculture	grassland	forestry	residence	infrastruct.	mining
natural/unused	0	$c_{1,2}$	$c_{1,3}$	-	$c_{1,5}$	$c_{1,6}$	$c_{1,7}$	$c_{1,8}$	$c_{1,9}$
protected	-	0	-	-	-	-	-	-	-
rainfed agriculture	-	-	0	$c_{3,4}$	-	-	$c_{3,7}$	$c_{3,8}$	-
irrigated agriculture	-	-	-	0	-	-	$c_{4,7}$	-	-
grassland	$c_{5,1}$	-	$c_{5,3}$	-	0	-	$c_{5,7}$	$c_{5,8}$	$c_{5,9}$
forestry	$c_{6,1}$	$c_{6,2}$	-	-	$c_{6,5}$	0	$c_{6,7}$	$c_{6,8}$	$c_{6,9}$
residence	-	-	-	-	-	-	0	-	-
infrastruct.	-	-	-	-	-	-	-	0	-
mining	$c_{9,1}$	-	-	-	-	-	-	-	0

- = not feasible,  $c_{hj}$  = cost of converting land in site class  $s$  from major land use  $h$  to major land use  $j$ .

- Establishment of a land-use type  $k$  in site class  $s$  may involve intertemporal planning, particularly in forestry. Therefore, we define three types of decision variables:
  - (i) activities denoting establishment of a land-use type  $k$  on a site class  $s$  in (current) period  $t$  for harvesting in (a future) period  $\tau$ ,  $AR_{s,k}^{t,\tau}$ ;
  - (ii) non-destructive harvesting activities,  $AH_{s,k}^t$ , where the main produce can be obtained repeatedly without destroying the plant in the process of harvesting after establishment of the land-use type. This applies, for example, to orchards, vineyards and various perennial plantation crops in agriculture;
  - (iii) destructive harvesting ('logging') activities,  $AL_{s,k}^t$ , where by harvesting the primary produce, the land cover is removed so that it has to be followed by some re-establishment activity before another harvest is possible; for instance, clear-cutting of forest.
- In the case of annual crops, establishment and harvest (destructive harvesting in our terminology, since the plant is removed by harvesting) fall into one period, i.e.  $AL_{s,k}^t = AR_{s,k}^{t,t}$ . Hence, the description can be simplified by including, by definition, the establishment activities and costs with the harvesting activity.
- Logging activities in forestry require proper establishment of land-use types, sometimes many periods in advance.
- For annual crops, by definition, we observe:

$$AR_{s,k}^{t,\tau} = \begin{cases} AL_{s,k}^t, & \tau = t \\ 0, & \text{else} \end{cases},$$

for perennial crops and forestry we impose:

$$AR_{s,k}^{t,\tau} = 0, \quad \tau \leq t + \Delta t_{s,k}^R$$

where  $\Delta t_{s,k}^R$  denotes the minimum time required for establishing land-use type  $k$  in site class  $s$ .

#### **8.4 Land-balance conditions and constraints on land use**

With these types of site class and land-use variables, as defined above, we proceed with formulating land balance constraints that must be observed in the land allocation

procedure. First, we note that land allocated to different major uses in a site class  $s$  is limited by the availability of that land quality<sup>17</sup>:

$$\sum_h A'_{s,h} = a'_s, \quad s = 1, \dots, S \quad (8.3)$$

In general, there will be conversion of land between major land-use categories, described by variables  $\Delta A'_{s,hm} \geq 0$ . All land in a site class  $s$  must fall into one of the defined major land-use categories:

$$A'_{s,h} = A'^{t-1}_{s,h} + \sum_{l=1}^H \Delta A'_{s,lh} - \sum_{l=1}^H \Delta A'_{s,hl} \quad s = 1, \dots, S \quad (8.4)$$

There is a limit as to how much land can be transferred in any period between major land uses<sup>18</sup>:

$$\sum_{h=1}^H \sum_{l=1}^H \Delta A'_{s,lh} \leq \rho'_s a'_s \quad s = 1, \dots, S \quad (8.5)$$

It is further assumed that conversion of land between major use categories is limited to land either newly entering the particular site class or having been subject to a destructive harvesting ('logging') activity<sup>19</sup> in the previous period:

$$\sum_{h=1}^H \sum_{l=1}^H \Delta A'_{s,lh} \leq \sum_{h \neq s} \Delta a'_{hs} - \sum_{h \neq s} \Delta a'_{sh} + \sum_{k=1}^K AL'^{t-1}_{s,k} \quad s = 1, \dots, S \quad (8.6)$$

Land available for establishment activities of various land-use types is limited by land in a major land-use class, either available from previous destructive harvesting activities, or resulting from net conversions between major land-use classes. In the specification of these constraints, index sets  $I_h$  denote the set of land-use types  $k$  that belong to major land-use class  $h$ , e.g. wheat and potato cultivation are both land-use types belonging to crop agriculture:

$$\sum_{k \in I_h} \sum_{\tau=t}^T AR'^{t,\tau}_{s,k} \leq \sum_{l=1}^H \Delta A'_{s,lh} - \sum_{l=1}^H \Delta A'_{s,hl} + \sum_{k \in I_h} AL'^{t-1}_{s,k} \quad s = 1, \dots, S, \quad h = 1, \dots, H \quad (8.7)$$

<sup>17</sup> Since we have defined a natural/unused major land-use class, we may assume an equality rather than an inequality to hold in (8.3).

<sup>18</sup> The formulation of land conversion flexibility constraints shown here is just one possible specification.

<sup>19</sup> Recall that annual crops are always subject to 'logging'.

Land available for harvesting activities is limited to land previously established<sup>20</sup>:

$$AH'_{s,k} + AL'_{s,k} \leq AH'_{s,k} + \sum_{\tau=1}^t AR'_{s,k} \quad s = 1, \dots, S, \quad k = 1, \dots, K \quad (8.8)$$

The treatment of land availability and land-use types, as introduced above, makes it easy to extend the specification of constraints to also include livestock production. This is particularly relevant with regard to ruminants. In that case two approaches can be considered: (i) either the number of ruminant livestock units and estimated (generally site-class specific) land requirements per livestock unit enter the respective land balance equations above, or (ii) grasses (and other fodder crops) are defined as land-use types, and the area and production of green-fodder is determined through a livestock feed-balance constraint (e.g., see Fischer *et al.* 1994b). As outlined in Section 9, the latter approach is more flexible and will be pursued in the LUC model.

In general, there will be limited resources other than land, e.g., irrigation water supply, that are also essential to successful cultivation of various land-use types. In the LUC model, we can distinguish two types of water supply that may exist in site class  $s$ , say  $WF'_s$  and  $WV'_s$ , denoting water supply available in fixed amounts and at a fixed cost (e.g., surface water), and variable water supply (e.g., pumped water described by a convex price-dependent supply function), respectively. Let  $w_{s,k}$  denote water requirements of land-use type  $k$  on site class  $s$ , and  $p_s^{WV}$  the respective price of pumped water. Then we impose the following set of constraints:

$$\sum_k \left( w_{s,k}^R \cdot \sum_{\tau=1}^T AR'_{s,k} + w_{s,k}^H \cdot AH'_{s,k} + w_{s,k}^L \cdot AL'_{s,k} \right) - WF'_s \leq WV'_s (p_s^{WV}) \quad s = 1, \dots, S \quad (8.9)$$

Note that constraint (8.9) could be used as a market-clearing condition to endogenize variable water supply in the model, i.e., derive the price of pumped water from balancing demand and supply.

---

<sup>20</sup>How the allocation of extents in different major land-use classes to harvesting and logging activities of various land-use types can be modeled based on economic principles will be discussed in the next section.

In a similar way, labor input constraints in terms of family labor LF (fixed) and hired labor LV (with a variable and price responsive supply) can be included, with  $l_{s,k}$  denoting labor requirements of land-use type  $k$  on site class  $s$ .

$$\sum_k \left( l_{s,k}^R \cdot \sum_{\tau=t}^T AR_{s,k}^{t,\tau} + l_{s,k}^H \cdot AH_{s,k}^t + l_{s,k}^L \cdot AL_{s,k}^t \right) - LF_s^t \leq LV_s^t(p_s^{LV}) \quad s = 1, \dots, S \quad (8.10)$$

Finally, environmental accounting and constraints can also be based on the concepts of site classes and land-use types. For instance, let  $e_{s,km}$  denote emissions of type  $m$  per unit of area of land-use type  $k$ , in site class  $s^{21}$ . Given a maximum tolerable amount of emissions of type  $m$  from site class  $s$ ,  $\bar{e}_{s,m}^t$ , the respective constraints would read:

$$\sum_k \left( e_{s,km}^R \cdot \sum_{\tau=t}^T AR_{s,k}^{t,\tau} + e_{s,km}^H \cdot AH_{s,k}^t + e_{s,km}^L \cdot AL_{s,k}^t \right) \leq \bar{e}_{s,m}^t \quad s = 1, \dots, S, \quad m = 1, \dots, M \quad (8.11)$$

In the model, these relationships (i.e., water supply, labor, and environmental constraints) are reflected in the set of constraints that we have termed the transformation function constraint in Section 6. Some of them apply to individual agents of the model; others induce joint constraints for groups of agents. When decentralizing the welfare program, the constraints will be implemented in the model through shadow price mechanisms, or through ‘trading’ type of processes (like pollution permits), or through rationing by a central institution (e.g., the government), depending on the characteristics of each constraint.

### **8.5 Geographic representation of site classes**

In the discussion on how to characterize and represent land resources and land use, we did not have to make any assumptions on what geographic representation, e.g., square mesh of grid points or polygon-shaped map units, would be best suited for modeling. If the grid size is not fixed ex-ante, as is often done in global change research (e.g., to  $1^\circ \times 1^\circ$  latitude - longitude grids), then any size polygons can be sufficiently well approximated by adjusting the grid dimensions. Conversely, data on any grid size can be converted into polygons. In the LUC model, we utilize pixel data in a gridded format. The advantage of pixel-wise representation in a grid is twofold:

---

<sup>21</sup> Emission coefficients can be time dependent. For convenience, we omit a time superscript.

- gridded data sets are easier and more practical to use in application programs;
- gridded data sets more readily allow the approximation of a continuous gradient of geographic features (e.g., Keyzer 1992).

This second point is especially important. When working with gridded data, the framework of site classes presented so far in this section remains valid, except that we have to somewhat generalize the interpretation of site classes. Rather than being fixed (and assumed homogenous) map units, site classes refer to a collection of grid points over which certain attributes vary within a defined (narrow) range. Consequently, relationships involving extents of site classes involve numerical integration, i.e., summation over a set of grid points, say index set  $I_s$ , of which a particular site class is comprised. For instance, constraints in (8.11) could be written as:

$$\sum_{g \in I_s} \sum_k \left( e_{g,km}^R \cdot \sum_{\tau=t}^T AR_{g,k}^{t,\tau} + e_{g,km}^H \cdot AH_{g,k}^t + e_{g,km}^L \cdot AL_{g,k}^t \right) \leq \bar{e}_{s,m}^t \quad (8.11a)$$

However, there is also a cost to such increased accuracy and flexibility, when working on a square mesh, since there will likely be a large increase in the number of decision variables relating to the resource allocation problem.

## 9. Specification of supply and demand functions

Interactions between the supply of land-based commodities and their consumption is a main driving force of land-cover change. In previous sections we have discussed this in more general terms. In this section we set forth some model specifications and illustrate the concepts with a few examples.

### 9.1 *Production in the LUC model*<sup>22</sup>

In economic models, production activities are usually organized in terms of economic sectors. For instance in the LUC model, at the highest aggregation level, the following sectors are distinguished: agriculture, forestry, and other non-agriculture. Sectors with a strong relation to land use are further subdivided. In particular, this applies to agriculture and forestry. The LUC sector representation is shown in Table 9.1.

In each sector a number of production conditions are distinguished. For example, agricultural production in a compartment is described as cumulative output from a collection of representative farms<sup>23</sup>. Such differentiation should reflect major differences in production conditions (agro-ecology, farm resources, infrastructure, etc.) and – for the purpose of modeling land-use and land-cover change in the LUC project – relate to the dominance of various driving forces. To be empirically founded, this requires appropriate data sets and advanced methods of spatial statistical analysis, and builds on in-depth analysis at representative case-study sites. Below we explain the approaches we use in modeling the agriculture sector. These approaches are based on economic principles, are consistent with the overall LUC modeling concept, allow the inclusion of technological and structural information, and deal explicitly with yields, input use and land allocation.

---

<sup>22</sup>This section draws heavily on Keyzer (1982, 1987) and Folmer *et al.* (1995).

<sup>23</sup>For economy of data collection and model building, the number of agents should be kept as small as possible, focused on the study objectives.

Table 9.1: Economic sectors in the LUC model.

Number	Aggregate Sector	Sector	Sub-sector	Product
1	agriculture	crops	cereals	wheat rice maize other
			root & tubers	potato other
			oilseeds	soybean other
			other food	sugar fruits vegetables
			non-food	cotton other
		livestock	ruminants	sheep goats cattle buffalo other
			non-ruminants	pigs poultry&eggs other
		fish	marine	fish
			inland	fish
		2	forestry	softwood
hardwood	logwood pulpwood fuelwood			
3	other	energy	biofuel	power
			other	power
		manufacturing		
		construction		
		transportation		
		other		



## 9.2 Modeling agricultural supply

There are several approaches to modeling agricultural supply. At least four different types have been widely used:

- (i) econometric models
- (ii) linear programming (LP) models
- (iii) simulation models of the systems dynamics type
- (iv) revenue function approaches.

Traditional econometric models are inappropriate for the purposes of the LUC project as they do not easily allow the inclusion of *a priori* technological information and structural relationships and constraints. In comparison, LP models follow an almost opposite approach. The LP modeler specifies structural relationships, resource constraints, *a priori* information on technology, etc., and assumes a rational 'farmer' who optimizes a measure of economic efficiency, e.g., net revenue. The disadvantage of the LP approach is that the resulting supply function is generally not a continuous function of input parameters, such as prices and resource stocks, i.e., right-hand sides of the constraint matrix. This is undesirable in the context of a welfare program because it complicates the solution procedure. System dynamics simulation models are inconsistent with welfare analysis because they are generally not based on accepted micro-economic principles. This class of models can easily exhibit unacceptable properties and should be avoided in the normative approach.

The representation of agricultural supply in the LUC model is based on a combination of nonlinear optimization and the revenue function approach, specifying the agricultural supply model in a mixed primal-dual form derived from the general formulation (6.9) in Section 6. It aims at maintaining the properties of the full primal mathematical program, yet simplifies the solution procedures and parameter estimation by decomposing the program (6.9) into several sub-problems. The sub-problems deal separately with, for instance, input use and yield levels, acreage allocation to different cropping activities, livestock feed-mix, and livestock activity levels. These sub-problems are related by means of feedback relationships that operate through linking constraints with known coefficients<sup>24</sup>. This enables us to impose *a priori* information, like land balances or feed balance constraints.

---

<sup>24</sup>As opposed to dual relationships that require parameter estimation.

The emphasis on decomposition is both for methodological considerations as well as for reasons of efficient solution algorithms. Decomposition of (6.9) exploits the structure of the full primal program to partition it into several sub-problems which are solved one by one and, in general, are related to each other through feedback variables. Some obvious advantages of such decomposition are:

- Each of the sub-problems is usually of a much smaller dimension than the full program and may be solved more efficiently.
- Testing of specifications and parameter estimation greatly benefit from reducing the dimensionality of the problem.
- Parameter estimation of resource allocation programming problems specified in primal form may be impossible due to lack of data on crop-specific input use (e.g., see Folmer *et al.* 1995). For that reason (amongst others), economists have developed dual approaches to facilitate model estimation.
- Solution algorithms can be tailored to exploit the specific features of individual sub-problems.

Fortunately, the structure of an agricultural supply model may be conveniently decomposed into several sub-problems. Let us start from the primal formulation of the agricultural supply program. For a profit-maximizing producer, the supply program can be written as in (6.9)<sup>25</sup>:

$$\Pi = \max_y \pi(p^1, \dots, p^T, y^1, \dots, y^T)$$

subject to: (9.1)

$$y^t \in Y^t$$

$$g(t, y^t, k^t, k^{t+1}) \leq 0$$

$$k^t \geq 0, \quad t = 1, \dots, T + 1$$

Net production  $y^t$  must be chosen from a feasible set  $Y^t$  subject to: (i) constraints defined by a transformation vector-function  $g(\cdot)$  describing the available technology, (ii) being consistent with available resource stocks  $k^t$ , and (iii) the need to maintain stocks of resources  $k^{t+1}$  for later time periods. In order to generate net outputs  $y^t$ , producers allocate

---

<sup>25</sup>For convenience of notation we drop the agent sub-script  $j$ .

resources  $k^t$  to alternative production activities, each of which generates output of one<sup>26</sup> commodity  $Q_k^t$ ,  $k = 1, \dots, K$ . A feasible allocation of resources  $\Phi_c^t = (\Phi_{ck}^t)$  of resources in compartment  $c$ , at time  $t$ , is defined according to (9.5)<sup>27</sup> (see also Section 7),

$$\sum_k \Phi_k^t \leq k^t, \quad t = 1, \dots, T \quad (9.2)$$

In Section 7 we defined the vector of resource stocks in a fairly broad sense, including capital, machinery, labor, energy, input materials, land resources, water, etc. When decomposing the full program (9.1), the aim is to partition the activity and resource vectors  $\Phi^t$  and  $y^t$  such that meaningful sub-problems can be solved separately. To exploit specific features of the structure of agricultural supply, the general scheme of (9.1) requires further specification. We model agriculture as consisting of two sub-sectors, i.e., crop cultivation and the livestock sub-sector. These are linked through competition for some of the scarce resources in the region (e.g., labor, capital, water, land). The crop sub-sector provides feedstuffs (green fodder as well as marketed feed concentrates) to the livestock sub-sector. In addition, the livestock sector may provide fertilizer and draught power to the crop sector. Therefore, with some additional assumptions about the structure of the agricultural sector we can rewrite the profit function and constraint set of (9.1) as<sup>28</sup>:

$$\begin{aligned} \Pi &= \max_y \pi(p, y) = \\ &= \max_{A, N, V, q} \sum_{k \in I_C} p_k A_k q_k + \sum_{k \in I_L} p_k N_k q_k - \sum_{k \in I_C \cup I_L} \sum_h \bar{p}_h V_{hk} \end{aligned} \quad (9.3)$$

subject to:

$$\begin{aligned} q_k &\geq f_k^C(p, V_k), \quad k \in I_C \\ g_C(A_1, \dots, A_{K_C}) &\leq 0 \\ q_k &\geq f_k^L(p, V_k), \quad k \in I_L \\ g_L(N_1, \dots, N_{K_L}) &\leq 0 \\ f(A_1, \dots, A_{K_C}, N_1, \dots, N_{K_L}) &\leq 0 \end{aligned} \quad (9.4)$$

where the vector functions  $f_k(\cdot)$  are yield response functions (see Section 9.3 below),  $q_k$  is yield,  $p_k$  is the farm-gate price of output  $k$ ,  $A_k$  refers to area cultivated for activity  $k$ ,

<sup>26</sup>Without loss of generality, we ignore the case of joint products which can be dealt with in the same way.

<sup>27</sup>For the sake of simplicity we omit the compartment sub-script  $c$ .

<sup>28</sup>To simplify the presentation, let us now consider only one time period and drop, where not necessary for the understanding, the super-script indicating time.

belonging to the set of cropping activities,  $k \in I_C$ , and  $N_k$  denotes livestock units for  $k$  belonging to the set of livestock activities,  $k \in I_L$ .  $V$  denotes the matrix of production inputs  $V_{hk}$  of type  $h$  into activity  $k$ , and  $\bar{p}_h$  is price of input type  $h$ . The vector functions  $g_C(\cdot)$  and  $g_L(\cdot)$  are transformation constraints for the crop and livestock sub-sectors, respectively. Vector function  $f(\cdot)$  describes the constraints linking the two sub-sectors. The specification of constraints in (9.4) decomposes the agriculture supply model into five sub-problems: (i) determination of crop yields and inputs; (ii) land allocation in crop sub-sector; (iii) determination of livestock yields and feed-mix; (iv) determination of livestock numbers, i.e., allocation of operating capacity in livestock sub-sector; (v) allocation of resources to crop and livestock sub-sector. The sub-problems are linked through feedback relationships derived from optimality conditions. For instance, the shadow price of green-fodder obtained by taking the derivative of the cost-function for the livestock sub-sector with respect to feed requirement constraints must be consistent with the price used for revenue calculation in the crop sub-sector model.

Clearly, decomposition and the solution procedure become more complicated when we allow for possible transfers of resources between compartments or sub-sectors, as in equation (7.6), and when intertemporal allocations are considered. Also, activities in the forest sector may in some areas compete for common resources, such as land. Then, the same type of decomposition technique is needed to deal with linkages between agriculture and forestry.

### **9.3 Specifying yield relations**

We turn now to one of the sub-problems of the agricultural supply model, the specification of yield relationships and the determination of input use. In the LUC model, agronomic information on crop yields are specified by a system of yield relations  $F_{hk}(V_{hk}, V_0)$ ,  $k = 1, \dots, K$ ,  $h = 1, \dots, H$ . Each of these relations indicates how much output  $Q_k$  will be obtained for a given combination of input  $V_{hk}$  with a reference input  $V_0$ , if other inputs are not constraining. The reference input  $V_0$ , in our case land or animal units, is the input which is common to all yield relations in the system. Since the system of yield relations refers to the same output  $Q_k$  and reference input  $V_0$ ,

$$Q_k = \min_h [F_{hk}(V_{hk}, V_0)], \quad h = 1, \dots, H, \quad k = 1, \dots, K \quad (9.5)$$

we can define output and input intensities,  $q_k$  and  $v_{hk}$ , respectively:

$$q_k = \frac{Q_k}{V_0}$$

and

$$v_{hk} = \frac{V_{hk}}{V_0} \quad h = 1, \dots, H, \quad k = 1, \dots, K.$$

Assuming linear homogeneity of  $F_{hk}$ , i.e.,  $F_{hk}(\lambda V_{hk}, \lambda V_0) = \lambda F_{hk}(V_{hk}, V_0)$ , we can define yield relations in relative form by:

$$f_{hk}(v_{hk}) = F_{hk}\left(\frac{V_{hk}}{V_0}, 1\right), \quad h = 1, \dots, H, \quad k = 1, \dots, K \quad (9.6)$$

and

$$q_k = \min_h [f_{hk}(v_{hk})] \quad (9.10)$$

The functions<sup>29</sup>  $f_h(\cdot)$  are termed branches of the system of yield relations. Each must be defined for  $v_h > v_h^{\min} \geq 0$ , have a fixed maximum yield, be continuous and single valued, and with a positive and non-increasing slope, i.e.,

$$\begin{aligned} f_h(v_h^{\min}) &> 0 \\ f_h(v_h) &= f_h^{\max} && \text{for all } v_h > v_h^{\max} \\ \frac{df_h(v_h)}{dv_h} &\geq 0 && \text{for all } v_h^{\min} < v_h < v_h^{\max} \\ \left. \frac{df_h(v_h)}{dv_h} \right|_{v_{1h}} &\geq \left. \frac{df_h(v_h)}{dv_h} \right|_{v_{2h}} && \text{for all } v_{1h} \leq v_{2h} \text{ and strict inequality for at least one } h. \end{aligned} \quad (9.7)$$

When such a system of yield relations is used in a programming model, the efficiency of the optimal allocation decision guarantees that inputs are not applied unnecessarily. A multidimensional yield relation is characterized by the assumption of non-substitutability between inputs of different branches, i.e., if the input intensity in the  $h$ -th branch is constraining then only an increase in the application of that input can increase yield fur-

---

<sup>29</sup>We drop the commodity index  $k$  for convenience of notation.

ther. For the broad categories of inputs to be represented in the LUC model (e.g., solar radiation, water, energy, fertilizer), this seems warranted. For instance, it is acceptable to assume that fertilizers cannot be substituted for water, nor can nitrogen fertilizer be substituted for phosphates. One can then model agricultural supply, for example, by net revenue maximization. For a set of crops  $k = 1, \dots, K$ , given output prices  $p_k$  and input prices  $p_h$ , and levels of reference input  $V_{ok} > 0$  (here the common input  $A_k = V_{ok}$  denotes acreage allocated to crop  $k$ ), we can write:

$$\max_V \sum_k (p_k q_k - \sum_h p_h v_{hk}) A_k$$

subject to: (9.8)

$$q_k = \min_h [f_{hk}(v_{hk})] \quad k = 1, \dots, K.$$

We define the cost function  $c_k(q_k)$  of producing crop  $k$  with yield intensity  $q_k$ :

$$c_k(q_k) = \sum_h p_h v_{hk}(q_k)$$

where  $v_{hk}(q_k)$  is the inverse function of  $f_{hk}(v_{hk})$ , indicating how much input of type  $h$  is required to obtain a given yield  $q_k$ . Revenue maximization can then be obtained by solving for an optimal solution  $q^*$  so as to equate marginal costs with marginal revenue:

$$\left. \frac{dc_k(q_k)}{dq_k} \right|_{q^*} = p_k \quad k = 1, \dots, K. \quad (9.9)$$

With some additional complication of mathematical notation and algebra, the system of yield relations can also be formulated to handle aspects such as joint products, constraints on inputs, substitution between human and machine labor, and livestock production (e.g., see Keyzer 1982).

#### 9.4 Consumer demand

Recall from the previous sections that we distinguish a number of commodities, indexed  $k = 1, \dots, K$ . A list of commodities to be considered at the retail level is shown in Table 9.2. The consumption of consumer  $i$  in time period,  $t = 1, \dots, T$ , is described by a consumption vector  $x_i^t = (x_{i1}^t, \dots, x_{iK}^t)$ . The consumer is limited by a budget constraint. Suppose the market price of commodity  $k$  at time  $t$  is  $p_k^t$  and  $p^t = (p_1^t, \dots, p_K^t)$  is a vector

of commodity prices. Income  $h_i^t$  of consumer  $i$  at time  $t$  is generated from exchange of endowments  $w_i^t$  (i.e., resources, sales of stocks, wage labor) and transfer payments  $b_i^t$  :

$$h_i^t = \langle p^t, w_i^t \rangle + \langle p^t, \sum_j \theta_{ij}^t y_j^t \rangle + b_i^t, \quad (9.10)$$

where  $\theta_{ij}^t$  is the share of consumer  $i$  in firm  $j$  at time  $t$ . (For the sake of simplicity of notation we do not consider taxation policies here). Therefore, the cost of the respective consumption bundle  $x_i^t$  is  $\langle p^t, x_i^t \rangle = \sum_k p_k^t x_{ik}^t$ , and the budget constraint at time  $t$  reads  $\langle p^t, x_i^t \rangle \leq h_i^t$ .

Table 9.2: Example of retail commodities in the LUC model.

Number	Sector	Sub-sector	Commodity	#
1	agriculture	cereals	wheat	1
			rice	2
			other grains	3
		roots and tubers	roots	4
		oils and fats	vegetable oil	5
			animal fat	6
		other food	sugar	7
			fruits	8
			vegetables	9
		non-food	cotton	10
			other	11
		meat	bovine and ovine	12
			pork, poultry, eggs	13
		milk	dairy products	14
		fish	fishery products	15
2	forestry	wood products	logwood	16
			pulpwood	17
			fuelwood	18
3	other	energy	fuel	19
			electricity	20
		manufacturing		21
		construction		22
		transportation		23
other		24		

Any vector  $x_i' \geq 0$  satisfying the budget constraint is regarded as a feasible demand of consumer  $i$ . Note that the feasibility of a demand trajectory  $x_i = (x_i^0, \dots, x_i^T)$  depends on prices  $p = (p^0, \dots, p^T)$  and income  $h_i = (h_i^0, \dots, h_i^T)$ . Any vector function  $x_i(p, h_i)$  satisfying the budget constraints for given  $p$  and  $h_i$  can be considered a *demand system*. Demand systems are typically obtained through econometric estimation. Various specifications have been derived from utility maximization, based on flexible specifications of the utility function. Assume the preferences of consumer  $i$  are described by an intertemporal utility function  $u_i(x_i)$ . Then, the vector function  $x_i(p, h_i)$  comprising the optimal solutions obtained by maximizing utility  $u_i(x_i)$  subject to budget  $h_i$  represents a demand system.

Various specifications befitting econometric estimation of parameters have been proposed in the literature. A well-known (and particularly simple) example is the demand system derived from a log-linear specification of the utility function, the Stone-Geary utility function, that has been often used in applied modeling. It is of the following form (dropping for convenience the subscript for consumer  $i$ ):

$$u(x) = \prod_{k=1}^K (x_k - \theta_k)^{\varepsilon_k} \quad (9.11)$$

which results in an explicit representation of the demand system  $x(p, h)$  as:

$$p_k x_k = p_k \theta_k + \varepsilon_k \left( h_i - \sum_{h=1}^K p_h \theta_h \right), \quad k = 1, \dots, K \quad (9.12)$$

When a large number of commodities is considered, as in the LUC model, nesting of the commodity tree is a standard technique for obtaining more robust estimates. For instance, Michalek and Keyzer (1992) discuss a two-stage approach applied to modeling (per capita) consumer behavior in the member countries of the EU, where at the higher level aggregate demand was estimated using an Almost Ideal Demand System, and for each commodity group separately (yet consistently) a Linear Expenditure System like in (9.12) was specified.



## 10. Risks and uncertainty

Up to now, we have assumed that the agents in the model have perfect foresight and act under full certainty. Of course, in reality, consumers, producers and governments do not have access to all the information they need to maximize intertemporal utility and profit. They are faced with uncertainty about their external environment (prices, markets, weather) and about their own production set (productivity of workers, reliability of equipment). Insurance schemes, a common mechanism to cope with and share risks, cannot be introduced for all possible uncertainties and risks involved. In practice, the aim is to combine economic schemes (like insurances), where they are feasible, with the choice of policies that are robust against possible ‘surprises’.

Uncertainty can be incorporated into optimization models, although this often leads to formulations which are intractable for applied work unless specialized tools are developed. However, disregarding uncertainty completely may lead to extreme supply reactions and over-specialization. For example, unrealistic combinations of crops entering the optimal solution is a common problem in deterministic optimization problems. It is often the case that the optimal solution in some compartment is dominated by crop specialization if uncertainty is ignored. In practice, risks associated with weather and the effects of other ‘exogenous’ and sometimes transient variables lead to diversification in crop mixes.

The land-use change study has to deal with at least two quite different types of uncertainties: (i) Objective uncertainty, say about rainfall in a particular year. A model builder shares this type of uncertainties with the agents (farmers, etc.) in the real world; (ii) Uncertainties of the model builder with respect to the quantification and specification of relationships, to the value of certain technical parameters, or to the political feasibility of implementing intended policies.

### 10.1 Sources of uncertainty

Uncertainty (and hence risk) exists due to a variety of reasons. We list examples of some important real-world sources of risk:

Variability of climate is a major concern of farmers in many parts of the world. In arid and semi-arid regions, rainfed agriculture is particularly sensitive to drought risks, and to variability in amount and distribution of rainfall. In other areas, notably fertile and densely

populated flood plains, the risk of flooding and water logging influences land-use strategies. Other risks, e.g., typhoons, hailstorms and frost, threaten human lives and crops with varying intensity. Global warming may increase the risk of the occurrence of extreme events.

Biological processes involved in agricultural production are also subject to environmental variations which can be difficult to control and give rise to unstable supplies. For instance, agriculturists in less developed regions face the risk of damage from pests and diseases that may be beyond their means of control.

The institutional and political setting within which decisions on land use take place may be uncertain as well. The future orientation of the Common Agricultural Policy (CAP) in the European Union may be as uncertain to many EU farmers as is the success of economic transformation and privatization in Eastern Europe and the former Soviet Union. There may also be uncertainties as to future environmental standards and limitations on land use. For example, the scientific uncertainty about the impacts of greenhouse gas emissions and potential global warming also affects planning and development in agriculture and forestry. A consequence of industrialization and increased use of fossil fuels is often acidification of soils which may hamper their buffering capacity and magnify the risk of 'chemical time-bombs, i.e., the rapid release of toxic substances from soils to the surrounding environment, in particular to groundwater.

There is also uncertainty about longer-term technological progress. What kind of technologies will be available to produce food, fibers and timber, or to cope with environmental problems and clean-up? At what cost will such technologies be available?

Furthermore, there are various uncertainties that relate to behavioral aspects of societies and economic agents. For instance, the dynamics of value systems and hence the preference structure of consumers cannot be known with certainty. Also, economic agents as well as governments may not be willing to reveal information to each other. Therefore, the future prospects of markets may be difficult to judge, resulting in major uncertainties as to future costs and benefits of investments. Investment decisions may involve irreversible transformations of the environment, or at least may be characterized as extremely costly in terms of options to reverse their impacts, but such consequences are difficult to predict.

Finally, there are methodological uncertainties. Non-stationarity and dynamics of disequilibrium have often been quoted as driving forces of economic processes. The existence of a unique equilibrium solution has been proven only under fairly strong assumptions about functional relationships describing demand and supply of commodities. When multiple equilibrium solutions exist there is uncertainty as to what processes lead to the selection of particular solutions and what the sensitivity is of this solution with regard to initial conditions.

We have listed a range of uncertainties that limit our ability, in fact render it impossible, to predict the future path of the interacting socio-economic and environmental systems. Some of the uncertainties can be included formally in the specification of the model components, i.e., the description of particular agents. Others are dealt with in a more general way by means of scenario assumptions and a policy framework. Rather than computing one solution for every possible outcome, which would lead to insurmountable problems of screening results, the study follows a stochastic programming approach, incorporating major uncertainties and appropriate economic mechanisms within the stochastic optimization model itself (Ermoliev and Fischer 1993).

## ***10.2 Variability in farm production conditions***

Traditional models often ignore possible variability in production conditions, simply by averaging them. This is equivalent to dealing with only one scenario of possible developments. In general, however, there may be an infinite number of scenarios, and the challenge is to find policies robust against all or most eventualities. Averaging deprives us of the diversity which may be necessary to meet risks, and may lead to wrong conclusions. Let us illustrate this by the following examples:

Example 10.1: Suppose there are two farms with the same crop structure and average yields, but with different variability of yield, e.g., due to weather conditions. It is clear that the farm with a larger variance in yields is more vulnerable and may be less profitable, but it is impossible to distinguish them on the basis of averaged data.

Example 10.2: Suppose there is only one type of soil and two crops, A and B. Crop A performs better in dry seasons, and crop B outperforms crop A in wet seasons. On average, the weather condition may only be dry or wet, implying a mono-cropping structure as an

optimal solution, i.e. cultivation of only crop A or only crop B. By taking into account probabilities for both weather conditions, dry and wet, the structure of the optimal solution is changed to a multicropping structure. Crop A and crop B are both included in the optimal solution in proportions related to frequencies of wet and dry seasons, prices on the market, etc.

### **10.3 Two-stage decision processes**

In the short term, the sustainable supporting capacity of a region, limited by prevailing conditions in 'bad' years, depends on the region's ability to adapt to changing conditions, e.g., through additional land management measures, food storage, or finance of additional imports and infrastructure for distribution. In the longer term, strategic decisions are needed to keep pace with the changing needs in a region. In the LUC model, these aspects are taken care of by incorporating two types of mechanisms:

- Long-term (ex-ante) strategic decisions such as investment in machinery, irrigation schemes, storage facilities, major land improvements, structure of livestock and cropping patterns, and
- Short-term adaptive (ex-post) decisions such as use of irrigation water, level of fertilizer application, allocation of manual labor and machinery in a given situation, change of planting dates, replanting of crops, etc.

Yields of crops and livestock are a result of human activity and management skills involving both ex-ante and ex-post decisions, and of natural endowments and characteristics, some of which are uncertain, like the occurrence of extreme events such as floods, droughts, or accidents.

Assume that each of these uncertain factors can be characterized by a finite number of scenarios with weights describing associated frequency distributions. For example, weather conditions could be classified by three<sup>30</sup> situations (scenarios): (1) dry season with frequency  $F_1$ , (2) wet season with frequency  $F_2$ , and (3) 'normal' season with frequency  $F_3$ . Other uncertain elements, such as technological innovations, could also be represented by a number of scenarios with subjective probabilities. Therefore, generally speaking, each

---

<sup>30</sup>Of course, more details could be incorporated, like characterizing weather conditions as 'dry and cold', 'dry and hot', 'wet and cold', etc.

scenario can be described by a vector  $s$  of integer numbers,  $s = (s_1, \dots, s_N)$ , where the components  $s_1, \dots, s_N$  are random variables assuming a finite number of integer values with given frequencies (probabilities). For example,  $s_1 \in \{s_{11}, s_{12}, \dots\}$  may represent scenarios of weather,  $s_2 \in \{s_{21}, s_{22}, \dots\}$  describes scenarios of flood hazard,  $s_3 \in \{s_{31}, s_{32}, \dots\}$  models scenarios of possible technological innovations, etc. Note that although the number of possible situations (scenarios) is finite, it may easily become very large.

Another important question relates to the dynamic aspects of the system and the timing of decisions. The ex-ante decision variables can be thought of as trajectories of strategic decisions over periods  $t = 1, \dots, T$ . The notion of ex-ante time dependent decisions is related to each particular period  $t$  and scenario  $s$ .

A scenario  $s$  then is itself comprised of a trajectory,  $s = (s(1), \dots, s(T))$ , where the components  $s(1), \dots, s(T)$  are random vectors. For instance, each  $s(t)$  may assume values  $s_1, s_2, \dots, s_S$  with probabilities  $F_1, F_2, \dots, F_S$  (which may themselves depend on time). Such types of models, even when the number of possible situations  $S$  for a given time period  $t$  is small, may require special stochastic optimization techniques, as the number of all possible combinations for  $t = 1, \dots, T$  may become astronomical. Hence, it may prove impossible or impractical to list and evaluate all possible combinations of situations, as would be required to solve the optimal decision problem by conventional optimization tools.

### **10.3 Irreversible decisions**

There is yet another issue of risk and uncertainty to be discussed. Strategic (ex-ante) decisions are defined as those which cannot be altered in response to an observed situation. In order to ensure flexibility of a system under such decisions, they are supplemented by a set of corrective (ex-post) decisions. Some strategic decisions, for instance, such as placing a dam, the use of nuclear energy, deforestation of tropical rainforests, etc., may involve irreversible transformations of the environment, or at least may be characterized as extremely costly in terms of options to reverse their impact. There is often considerable uncertainty at the time when a decision must be taken, as to future costs and benefits associated with the irreversible decision.

In order to reduce the risks involved in irreversible decisions, Arrow and Fisher (1974) suggested that, in the presence of uncertainty, decisions should be only partially accepted and applied in the initial stage, and can then be corrected by learning from experience. For example, under-investment can be remedied before the second time-period; uneconomic over-investments, although impossible to be corrected, would be limited so as to avoid costly losses. The challenge is to determine the robust elements of irreversible decisions for adoption during the initial stage.

We consider now a simple example illustrating that an otherwise appropriate formulation of a supply model may be inadequate and degenerate to simplistic conclusions without consideration of an (at least) two-stage decision process. For example, the productivity of land at a given geographical location is an indicator of the local economic conditions and environmental properties. These are subject to stochastic variation as well as dynamic changes. Land productivity may be affected, for instance, by variations in water supply which may be due to seasonal or inter-annual fluctuations, i.e., stochastic, or to a changing climate, i.e., a dynamic change manifesting itself in a gradual change of stochastic properties, e.g. frequency of droughts or floods. The example demonstrates that the value of land in a particular region is a rather complicated function of different factors. An analysis of the sensitivity of this function to potential climate change, through variations of water resources, may reveal that their relevance to the welfare of the region is negligible as compared to, for instance, mismanagement of regional capital resources or accidental pollution (Ermoliev and Fischer 1993).

Consider a region with only two compartments. The agricultural performance of the first compartment can be improved by irrigation, whereas in the second compartment additional water resources are not available. Furthermore, the maximum level and efficiency of irrigation depends on the water level of the river. If the water level is characterized by its average amount, the decision to use irrigation is trivial and depends, for instance, on whether the net revenue per hectare of irrigated area in the first compartment is greater than the profit from a hectare without use of irrigation. The stochastic variation of the river water level creates essential differences. In situations of low water levels, the land prepared in advance can only be partially supplemented with additional water. Besides these physical limitations, profits will also be affected by variations in water price. It is possible

that in a dry season the use of irrigation water may become unprofitable although irrigation is beneficial at average conditions.

## 11. Summary

The LUC project is aimed at the analysis of spatial and intertemporal interactions among various socio-economic and biogeophysical factors that drive land-use and land-cover change. Exact prediction of such complex systems over medium and long time-horizons is impossible. Instead, we emphasize the role of comparative studies of the impacts from various demographic, economic and political factors on the dynamics of land-use and land-cover change. Taking this into account, a model specification where policies and decisions of economic agents are explicitly introduced becomes essential.

From an economic perspective, the interactions between climate, land resources and vegetation are part of physical transformation processes of resource and capital stocks induced by human investments and dis-investments. A key interest is in describing patterns and conditions of land resources development and investment that are Pareto-efficient, i.e., such that no one could be better off without someone else being worse off. In this analysis, equity considerations are obviously relevant as well. Otherwise, these investments may leave certain regions without sufficient resources or deprive future generations.

In the LUC project, the intention is to describe such socially desirable and economically efficient trajectories of investments and resource use. These trajectories represent a welfare optimum in which the levels of investments are determined and with weights on the individual agents' utilities set so as to have them satisfy their budgetary (and other) constraints. Though such a solution may be regarded an unachievable ideal, it can serve to draw a line between real-world problems (i) that are due to fundamental technical relations, or to incompatible dynamics, e.g., of population growth, and (ii) those which are attributable to specific modes of social organization and institutional setting. While the former will persist in any projected trajectories of future development, the latter only appear as one introduces imperfections in the decentralization of the welfare optimum. After the specification of technical relations, and the characterization and computation of a welfare optimum, the issue of decentralization can be addressed. Here, the focus lies on external effects in production, i.e., effects on resource accumulation that are not conveyed through commodity prices, in which case corrective policy actions may be required.



The task poses some essential methodological challenges of this task. The study of spatial and intertemporal interactions and the computation of consistent welfare weights leads to large-scale nonlinear problems where uncertainty and unpredictability play an essential role in the overall evaluation of different policies.

External effects are present in virtually all environmental problems, because at present, resources, like fresh air and clean water, are often not being priced appropriately, i.e., valuations do not take into account all the services that are directly or indirectly provided to society. Hence, excessive utilization by some will always have external effects on others. The LUC project aims to make this notion more precise in several respects. For example, simulations with the LUC model may illustrate that due to its beneficial effect on climate, any land with an intact vegetation cover produces valuable 'output', even if no human activity is undertaken on it.

Once an adequate mode of decentralization has been found, an attempt will be made to incorporate the real-world imperfections that explain the difference between observed trends and welfare-optimal trajectories. This part of the analysis may have to be crude, due to paucity of data and also due to the necessary level of aggregation in the continental-scale LUC model. Yet, this final part of the analysis should go beyond the formulation of 'ideal' policies and suggest policies that are both realistic and conducive to reaching long-term sustainability.

To achieve the objectives outlined in this paper, the activities of the LUC project in the continental-scale study are organized at three broad levels, as shown in Figure 11.1. The most general stratum is termed the *scenario framework*. Data collection and analysis at this level serve (i) to embed the study region in the wider geographical global context, and (ii) to develop trajectories of variables which are not dealt with inside the LUC model, but that are important to the decisions of consumers, such as income derived from non-land-based economic sectors (i.e., other than agriculture and forestry), and to the decisions of land-managers, including policy-formulation, technological development, and possible changes of the climate system (Toth 1995).

The second stratum of the organization refers to the continental-scale study region. At this level, a *geographic information system and databases*, the LUC-GIS, is being developed that will allow for various biogeophysical assessments in relation to the

dynamics of natural vegetation (van Minnen *et al.* 1995), land productivity (Rosenzweig *et al.* 1995), land degradation, and hydrology, and for the analysis of socio-demographic factors (Heilig 1995). These analyses are essential inputs to the database and parameterization of the centerpiece of the LUC study, the *LUC Core Model*, which has been outlined in this paper.

In parallel to and in support of the development of the continental-scale LUC model, several case studies in representative ecological and socio-economic settings are being undertaken. These case studies are implemented by local study teams and provide the opportunity for in-depth analysis of regionally specific land-use issues. A number of case study areas have been identified and collaborating teams established in China, Japan and Russia. Figure 11.2 shows the geographical distribution of the case study sites within the continental-scale study region.

Figure 11.1: LUC Modeling Framework

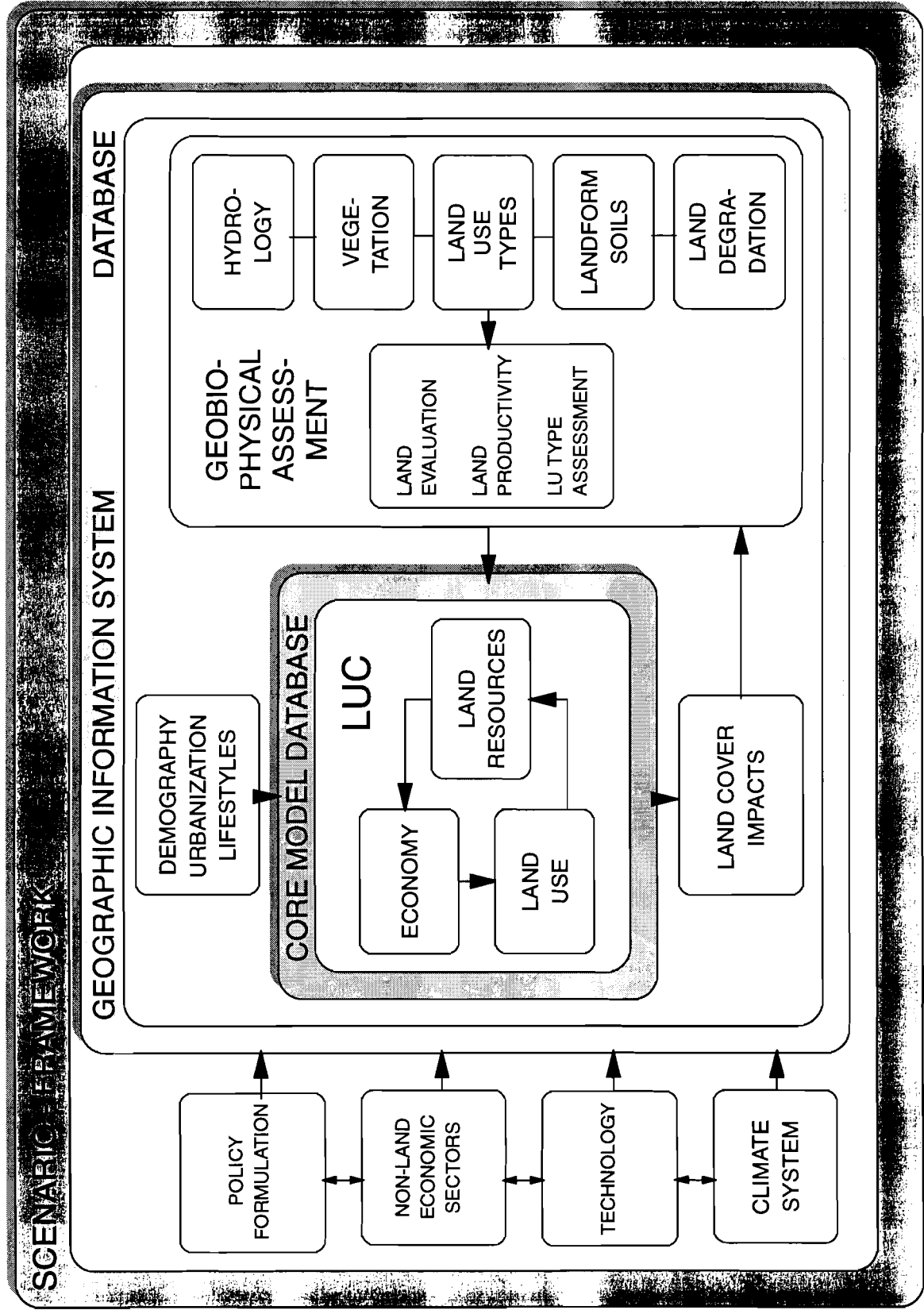

# LUC IIASA Case Studies

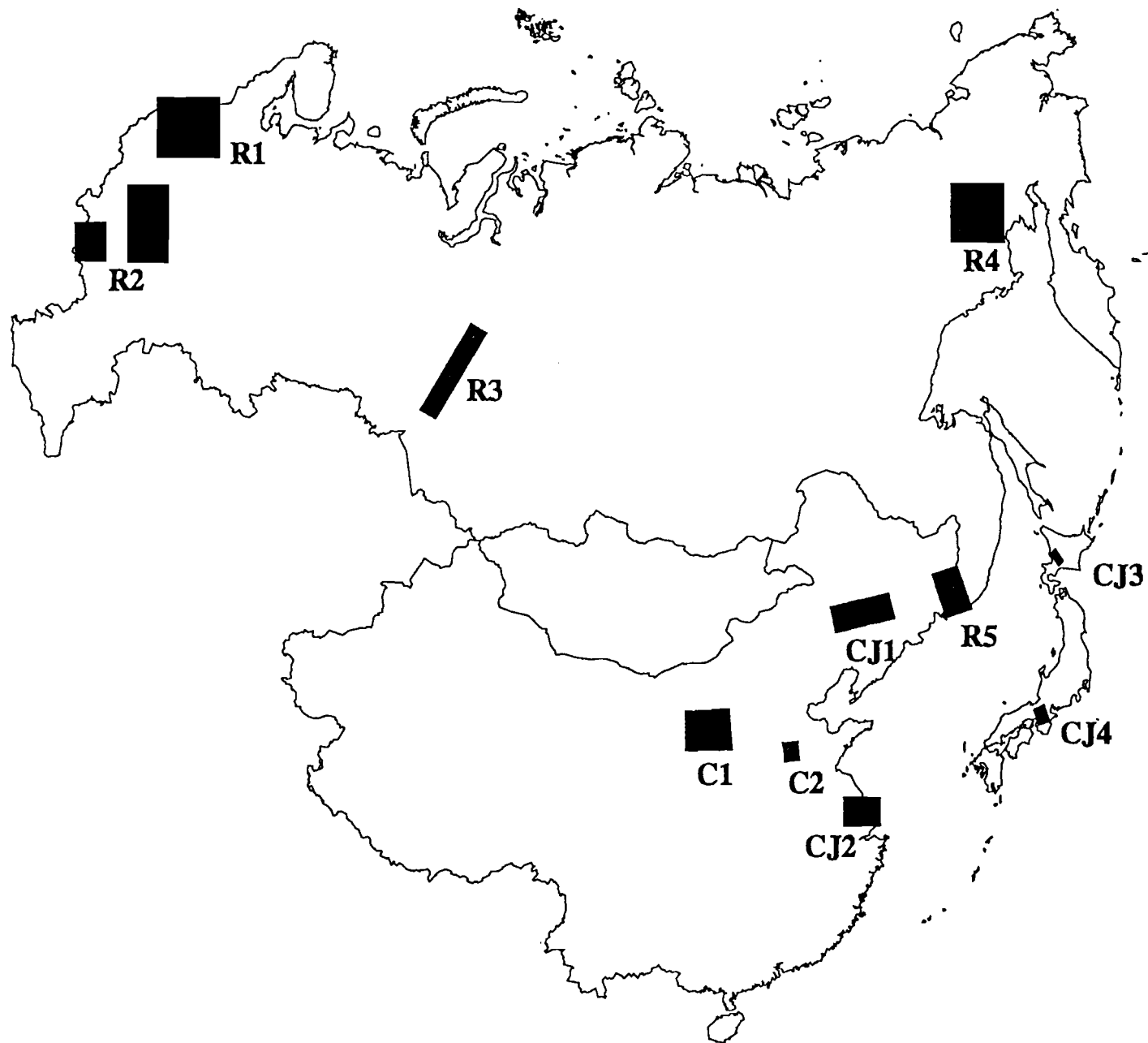

- Case Studies in RUSSIA
  - R1: North-Western
  - R2: Central European
  - R3: Western Siberian
  - R4: North-Eastern
  - R5: Far-Eastern
- Case Studies in CHINA
  - C1: Yulin Prefecture
  - C2: Liaocheng
- Case Studies in JAPAN and CHINA  
(financed by Japanese institutions)
  - CJ1: Changchun Area
  - CJ2: Shanghai and Nanjing Area
  - CJ3: Central Part of Hokkaido Island
  - CJ4: Hanshin metropolitan area

Figure 11.2: LUC IIASA Case Studies

## References

- Adams, D.M., R. Alig, J.M. Callaway, B.A. McCarl, 1994. *Forest and Agriculture Sector Optimizaion Model: Model Description*. RCG/Hagler Bailly, PO Drawer O, Boulder, CO 80306-1906.
- Adams, R.M., R.A. Fleming, C. Chang, B.A. McCarl, and C. Rosenzweig, 1993. *A Reassessment of the Economic Effects of Global Climate Change on U.S. Agriculture*. Oregon State University.
- Alcamo, J. (ed.), 1994. *IMAGE 2.0: Integrated Modeling of Global Climate Change*. Kluwer Academic Publishers, Dordrecht.
- Binswanger, H. P. and V. W. Ruttan, 1978. *Induced innovation: Technology, institutions and development*, Johns Hopkins University Press, Baltimore.
- Armington, P.A., 1969. *A theory of demand for products distinguished by place of production*. IMF Staff Papers, (16):159-178.
- Arrow, K. J. and A. C. Fisher, 1974. *Environmental Preservation, Uncertainty and Irreversibility*. The Quarterly Journal of Economics, 2, 312-319, 1974.
- Brinkman, R., 1987. *Agro-ecological characterization, classification and mapping. Different approaches by the international agricultural research centres*. In: A.H. Bunting (eds.), *Agricultural Environments. Characterization, Classification and Mapping*. C.A.B. International, Wallingford, UK, pp. 31-42.
- Brooke, A., D. Kendrick and A. Meeraus, 1992. *GAMS, a User's Guide, Release 2.25*. Danvers, MA: International Thomson Publishing.
- Burmeister, E., 1980. *Capital theory and dynamics*. Cambridge University Press, Cambridge.
- Debreu, G., 1959. *Theory of value*. Wiley, New York.
- Emanuel, W.R., Shugart, H.H. and Stevenson, M.P., 1985. *Climatic change and the broad-scale distribution of terrestrial ecosystems complexes*. *Climatic change*, 7: 29-43.
- Ermoliev, Y. M. and G. Fischer, 1993. *Spatial modeling of resource allocation and agriculture production under environmental risk and uncertainty*. WP-93-11, International Institute for Applied Systems Analysis, Laxenburg, Austria, 38 pp.
- FAO, 1978. *Report on the agro-ecological zones project*. Vol 3. Methodology and results for South and Central America. World Soil Resources Report 48/3. , Food and Agricultural Organization of the United Nations, Rome, pp. 251.
- FAO, 1995. *World Agriculture: Towards 2010, An FAO Study*. Edited by N. Alexandratos, Food and Agricultural Organization of the United Nations and J. Wiley & Sons, England, pp. 488.
- FAO/IIASA, 1993. *Agro-ecological assessments for national planning: the example of Kenya*. FAO Soils Bulletin 67, FAO, Rome.
- FAO/IIASA/UNFPA, 1982. *Potential population supporting capacities of lands in the developing world*. Technical Report on Project INT/513, FAO, Rome.
- Fischer G., K. Frohberg, M.A. Keyzer, and K.S. Parikh, 1988. *Linked national models: A tool for international policy analysis*. Kluwer Academic Publishers, Netherlands,

214 pp.

- Fischer, G., Y. Ermoliev, M.A. Keyzer, 1993. *Towards integrated modeling of land-use and land-cover change under environmental risk and uncertainty*. Paper prepared for Oxford Workshop on Land-Use/Cover Change (IGBP-HDP), Oxford 16-19 November, 27 pp.
- Fischer, G., K. Froberg, M. L. Parry, and C. Rosenzweig, 1994a. *Climate change and world food supply, demand and trade: Who benefits, who loses?*, *Global Environmental Change* 1994 4(1):7-23.
- Fischer, G. and J. Antoine, 1994b. *Agro-ecological land resources assessment for agricultural development planning, A case study of Kenya, Making land use choices for district planning*. World Soil Resources Report 71/9, Food and Agriculture Organization, Rome, and International Institute for Applied Systems Analysis, Laxenburg, Austria, 84 pp.
- Fischer, G. and H.T. van Velthuis, 1995. *Climate change and global agricultural potential, A case study of Kenya*. WP-95-??, International Institute for Applied Systems Analysis, Laxenburg, Austria, (forthcoming), 50 pp.
- Folmer, C., M.A. Keyzer, M.D. Merbis, H.J.J Stolwijk, and P.J.J Veenendaal, 1995. *The Common Agricultural Policy beyond the MacSharry Reform*. Elsevier Science, North-Holland, Amsterdam.
- Forrester, J.W., 1971. *World Dynamics*. Wright Allen Press.
- Ginsburgh, V. and M.A. Keyzer, (forthcoming). *The structure of Applied General Equilibrium Models*. Cambridge, Mass.: MIT-Press.
- Guang, X. and W. Zhihong, 1993. *Climate change and its technical and institutional adaptations: China's perspective*. Workshop on Mitigation, Impacts and Adaptation to Climate Change, International Institute for Applied Systems Analysis, Laxenburg, Austria.
- Gunning, J.W. and M.A. Keyzer, 1995. *Applied general equilibrium models for policy analysis*, in: J. Behrman and T.N. Srinivasan (eds.), *Handbook of Development Economics*, Vol. IIIA, Amsterdam: North Holland.
- Hayami, Y. and V. W. Ruttan, 1985. *Agricultural development: An international perspective*. Johns Hopkins University Press, Baltimore.
- Heilig, G., 1995. *Anthropogenic Driving Forces of Land-use Change in China*. Working Paper, International Institute for Applied Systems Analysis, Laxenburg, Austria, 41pp.
- Hertel, T.W. (ed.), 1995. *Global trade analysis: Modeling and applications*. Cambridge University Press, (forthcoming).
- Houghton, R.A., 1991. *Releases of carbon to the atmosphere from degradation of forests in Tropical Asia*. *Canadian Journal of Forestry Research*, 21: 132-142.
- Hulme, M., Wigley, T., Jiang, T., Zhao, Z.-c., Wang, F., Ding, Y., Leemans, R. and Markham, A., 1992. *Climate change due to the greenhouse effect and its implications for China*. WWF, Gland, Switzerland, 57 pp.
- Jin Z., D. Ge, H. Chen, and J. Fang, 1995. *Effects of Climate Change on Rice Production and Strategies for Adaptation in Southern China*. In: *Climate Change and Agriculture: Analysis of Potential International Impacts*, edited by C. Rosenzweig,

- J.T. Ritchie, J.W. Jones, G.Y. Tsuji, and P. Hildebrand, ASA Special Publication Number 59.
- Keyzer, M.A., 1982. *On the representation of technical information in an agricultural programming model*. Staff working paper SOW-82-5, Centre for World Food Studies SOW-VU, Free University, Amsterdam.
- Keyzer, M.A., 1987. *On the specification and parameter estimation of a decomposed, mixed primal-dual model of agricultural supply*. Staff working paper SOW-87-15, Centre for World Food Studies SOW-VU, Free University, Amsterdam.
- Keyzer, M.A., 1992. *Land evaluation: Towards a model representation*. Staff working paper SOW-92-05, Centre for World Food Studies SOW-VU, Free University, Amsterdam.
- Keyzer, M.A., 1994. *Resource conservation in overlapping generation models*. Invited paper at the EAAE-Seminar held in Vienna on *The role of agricultural externalities in high income countries*. Staff working paper SOW-94-06, Centre for World Food Studies, Amsterdam.
- Kitamura, T., M.L. Parry, G. Fischer, R. Leemans, V. Rojkov, Y. Satoh, V. Stolbovoy, F. Toth, and Y. Liu, 1994. *Modeling land use/cover change in Europe and Northern Asia*. A proposal to the International Institute for Applied Systems Analysis, International Institute for Applied Systems Analysis, Laxenburg, Austria, (unpublished).
- Leemans, R. and Solomon, A.M., 1993. *The potential response and redistribution of crops under a doubled CO<sub>2</sub> climate*. *Climate Research*, 3: 79-96.
- Malthus, T.R., 1982. *An Essay on the Principle of Population, as it effects the future improvement of society* (1798). Hammondsworth: Penguin Classics.
- Meadows, D.H., D.L. Meadows, J. Randers and W.W. Behrens, 1972. *The Limits to Growth: A report for the Club of Rome's project on the predicament of mankind*. London: Earth Island.
- Norse, D., 1993. *Towards a design for a LUCC modelling system*. Briefing Paper prepared for the Oxford Workshop on Land-Use/Cover Change (IGBP-HDP), Oxford 16-19 November, 7 pp.
- Parry, M.L., Carter, T.R. and Konijn, N.T. (eds.), 1988a. *The Impact of Climatic Variations on Agriculture*. Volume 1: Assessments in Cool Temperate and Cold Regions. Kluwer Academic Publishers, Dordrecht. 876 pp.
- Parry, M.L., Carter, T.R. and Konijn, N.T. (eds.), 1988b. *The Impact of Climatic Variations on Agriculture*. Volume 2: Assessments in Semi-arid Regions. Kluwer Academic Publishers, Dordrecht. 764 pp.
- Parton, W. J., D. S. Schimel, C. V. Cole and D. S. Ojima, 1987. *Analysis of factors controlling soil organic matter levels in Great Plains grasslands*. *Soil Sci. Soc. Am. J.* 51:1173-1179.
- Parton, W. J., J. W. B. Stewart, and C. V. Cole, 1988. *Dynamics of C, N, P and S in grassland soils: a model*. *Biogeochemistry* 5: 109-131.
- Parton, W. J., J. M. O. Scurlock, D. S. Ojima, T. G. Gilmanov, R. J. Scholes, D. S. Schimel, T. Kirchner, J.-C. Menaut, T. Seastedt, E. G. Moya, A. Kamnalrut, and J. I. Kinyario, 1993. *Observations and modeling of biomass and soil organic mat-*

- ter dynamics for the grassland biome worldwide.* Global Biogeochemical Cycles, 7:785-809.
- Rosenberg, N. J., and P. R. Crosson, 1991. *The MINK project: A new methodology for identifying influences of, and responses to, increasing atmospheric carbon dioxide and climate change.* Environmental Conservation, 18:313-322.
- Rosenzweig, C., M.L. Parry, G. Fischer, and K. Frohberg, 1993. *Climate change and world food supply.* Research Report No. 3., Environmental Change Unit, University of Oxford, Oxford, 28 pp.
- Rosenzweig, C. and A. Iglesias, 1995. *Modeling land-use and land-cover changes in Russia and Northern China. Research protocol for agricultural assessment.* Working Paper, International Institute for Applied Systems Analysis, Laxenburg, Austria.
- Ruttan, V. W. and Y. Hayami, 1988. *Induced technical change in agriculture.* in: Agricultural productivity measurement and explanation, S. M. Capalbo and J. M. Antle (eds.), Resources for the Future, Washington D.C.
- Simpson, J. R., 1993. *Urbanization, agro-ecological zones and food production sustainability.* Outlook on Agriculture 22(4):233-239.
- Solomon, A.M., 1986. *Transient responses of forests to CO<sub>2</sub>-induced climate change: simulation modeling in eastern North America.* Oecologia (Berlin), 68: 567-579.
- Stern, P. C., O. R. Young, and D. Druckman (eds.), 1992. *Global environmental change: understanding the human dimensions.* National Research Council Report, Washington D. C.
- Tiffen, M. and M. Mortimore, 1992. *Environment, population growth and productivity in Kenya: A case study of Machakos district.* Development Policy Review, vol. 10, pp. 359-387.
- Toth, F., 1995. *The socio-economic context of land-use changes in Europe and Northern Asia.* Working Paper, International Institute for Applied Systems Analysis, Laxenburg, Austria.
- Turner, B.L., II, Clark, W.C., Kates, R.W., Richards, J.F., Mathews, J.T. and Meyer, W.B. (eds.), 1990. *The Earth as transformed by Human Action: Global and Regional Changes in the Biosphere over the past 300 years.* Cambridge university Press, Cambridge. 725 pp.
- Turner, B.L., II, Moss, R.H. and Skole, D.L., 1993. *Relating Land Use and Global Land-Cover Change: A Proposal for an IGBP-HDP Core Project.* IGBP Rep. No. 24 and HDP Rep. No. 5., International Geosphere-Biosphere Programme and the Human Dimensions of Global Environmental Change Programme, Stockholm, pp. 65.
- UNEP/ISSS/ISRIC/FAO, 1995. *Global and national soils and terrain digital databases (SOTER), Procedures manual (revised edition).* V.W.P. van Engelen and T.T. Wen (eds.), International Soil Reference and Information Centre, Wageningen, The Netherlands, 125 pp.
- van Minnen, J.G., G. Fischer, and V. Stolbovoi, 1995. *A Land-Cover Classification for Modeling Natural Land Cover within the IASA LUC Project,* Working Paper, International Institute for Applied Systems Analysis, Laxenburg, Austria.
- van Velthuisen, H.T., G. Fischer, M.M. Saleem, M.M. Shah, and R. von Kaufmann, 1995. *Potential of forage legumes in land-use intensification. Towards sustainable crop-*



- livestock systems in West Africa. Vol.1 Primary land productivity assessment.* WP-95-80, International Institute for Applied Systems Analysis, Laxenburg, Austria, 109 pp.
- Vloedveld, M. and Leemans, R., 1993. *Quantifying feedback processes in the response of the terrestrial carbon cycle to global change - the modeling approach of IMAGE-2.* Water Air and Soil Pollution, 70: 615-628.
- WRI, 1992, *World Resources 1992-93, A Guide to the Global Environment.* The World Resources Institute, Oxford University Press.
- Young, A., 1993. *Land use and land cover: principles, glossary and an outline classification.* Draft Interim Report , FAO, Rome, pp. 74.
- Zuidema, G. and van den Born, G.J., 1994. *Simulation of global land-cover changes as affected by economic factors and climate.* Water, Air and Soil Pollution, Vol. 76, Nos. 1-2, 1994.