

Modeling and Explaining the Phosphorus Dynamics of Lake Balaton, 1976-1979

Leonov, A.V.

**IIASA Research Report
March 1985**



Leonov, A.V. (1985) Modeling and Explaining the Phosphorus Dynamics of Lake Balaton, 1976-1979. IIASA Research Report. Copyright © March 1985 by the author(s). <http://pure.iiasa.ac.at/2600/> All rights reserved. Permission to make digital or hard copies of all or part of this work for personal or classroom use is granted without fee provided that copies are not made or distributed for profit or commercial advantage. All copies must bear this notice and the full citation on the first page. For other purposes, to republish, to post on servers or to redistribute to lists, permission must be sought by contacting repository@iiasa.ac.at

**MODELING AND EXPLAINING THE PHOSPHORUS DYNAMICS
OF LAKE BALATON, 1976–1979**

Alexander Leonov

*International Institute for Applied Systems Analysis,
Laxenburg, Austria and Institute of Water Problems,
Academy of Sciences of the USSR, Moscow, USSR*

RR-85-3

March 1985

**INTERNATIONAL INSTITUTE FOR APPLIED SYSTEMS ANALYSIS
Laxenburg, Austria**

International Standard Book Number 3-7045-0075-5

Research Reports, which record research conducted at IIASA, are independently reviewed before publication. However, the views and opinions they express are not necessarily those of the Institute or the National Member Organizations that support it.

Copyright © 1985
International Institute for Applied Systems Analysis

All rights reserved. No part of this publication may be reproduced or transmitted in any form or by any means, electronic or mechanical, including photocopy, recording, or any information storage or retrieval system, without permission in writing from the publisher.

Cover design by Martin Schobel

Printed by Novographic, Vienna, Austria

SUMMARY

This report describes a mathematical modeling and systems study of the eutrophication problem in Lake Balaton, Hungary. Since it is generally agreed that phosphorus exerts a major influence on the direction of trophic change within the lake, the work focused on the dynamics of the phosphorus level in the lake ecosystem over the period 1976–1979. The Balaton Sector Model (BALSECT), one of three ecological models developed at IIASA for examining phosphorus dynamics and phytoplankton growth in the lake ecosystem, was used to simulate the basic biological and chemical interactions between phosphorus compartments in the aquatic environment. BALSECT also considers sediment–water phosphorus exchange and horizontal phosphorus transfer between the different basins of the lake by advective and wind-induced water flows.

The study addressed five specific topics. First, the adequacy of the model was assessed by means of statistical tests. Second, the phosphorus flows, external and internal, in the Balaton ecosystem were analyzed. Third, quantitative estimates were made of the role of sediment in overall phosphorus dynamics and in the phosphorus balance between major compartments. Fourth, the dynamics and mean values of turnover times for each phosphorus compartment were evaluated. Finally, simulations of phosphorus load changes were carried out, in order to assess the responses of the lake and to identify simple correlations between phosphorus loading and concentrations of major phosphorus fractions in the lake water as well as internal phosphorus flows within the system.

Biochemical interactions between the five phosphorus compartments of major importance in the Lake Balaton ecosystem (dissolved inorganic, dissolved organic, inanimate particulate organic, phytoplankton, and bacterial) are explicitly represented in BALSECT. The model was applied to a set of original field observations of water temperature, wind, solar radiation, and water balance to investigate the dynamics of each compartment in the four basins of the lake during the period 1976–1979. Model results for each compartment were calculated as monthly, seasonal, and annual mean values, the standard deviations of these means were also calculated to assess the dynamic properties of each phosphorus fraction.

Three statistical tests were used to assess the adequacy of the model. In the first test, the ratio of variances between simulated and observed phosphorus data was estimated to vary in the range 48.5–122.2% (mean 51.5%) for the period 1976–1979. In the second test, the quantitative relationship between phosphorus compartment levels in the observed and simulated time series was studied by regression analysis, both simple and weighted. On the basis of this test, the model described reasonably well the ranges of fluctuation of all the phosphorus compartments as well as the basic trends underlying temporary changes in phosphorus concentration in the individual basins of the lake. Theil's inequality coefficient was calculated in the third test for each phosphorus compartment on the basis of field observations and simulation results. Overall errors in modeling phosphorus compartment dynamics were evaluated in this test as 0.276, 0.277, 0.219, and 0.307

for the years 1976–1979, respectively, and as 0.279 for the entire four-year period.

Special calculations of phosphorus flows were performed for all phosphorus-dependent activities and sources in the watershed area. The resulting time distributions and other quantitative information on phosphorus load were used in the comparative analysis of the phosphorus contributions from each of the external sources considered.

The role of sediments as a source of phosphorus was evaluated in some detail. Sediments appear to be of major importance in the Lake Balaton phosphorus cycle and specifically in the process of eutrophication. Overall there was a continual and marked tendency for phosphorus to accumulate in the sediments in all seasons during the period studied, 1976–1979. Net particulate phosphorus losses to the sediments as a result of the imbalance between resuspension and sedimentation were estimated to be higher in the spring and summer months, when the rates of the ecological phosphorus transformation processes are highest and the total amount of particulate phosphorus formed biochemically is most significant. The amount of dissolved inorganic phosphorus released from the sediment was found to be significant only during the spring and summer months, but even this process only partially compensated for the total phosphorus losses caused by sedimentation.

The phosphorus cycle in Lake Balaton was examined further by analyzing four different types of phosphorus flux. This involved separate estimates of external input–output, system, compartment, and total phosphorus flux for each basin of the lake, and made it possible to assess the relative importance of external loading as opposed to internal transformation processes. External loading was found to have its most pronounced effect on the fluxes of dissolved inorganic phosphorus in Basin I (Keszthely Bay), presumably because this is where the Zala river joins the lake, but it was not found to play such a major role elsewhere. In contrast, for dissolved organic phosphorus the process of internal phosphorus cycling appeared to be of much greater importance than external loading throughout the lake. A stable balance was found to exist between all the processes, external and internal, that supply particulate phosphorus, and the role of hydrodynamic transport varied very little, either between basins or in different years.

The main features of the lake ecosystem and the roles of individual compartments in the phosphorus cycle were also analyzed by considering simulated phosphorus dynamics and fluxes. Flux rates, pool sizes, and turnover times were computed for individual phosphorus compartments. Overall, the turnover times reflected the complex relationships existing between environmental conditions, nutrient loading, and the limnetic properties of the water body. It was shown that observed patterns in the daily mean turnover-time dynamics are specific to definite biological and chemical compartments. Phosphorus pools appear to turn over fastest in the biological compartments, bacteria and phytoplankton, and for the inanimate particulate organic phosphorus that is directly dependent on microorganism activity.

The turnover times calculated show that all phosphorus fractions are much more mobile in Basin I (Keszthely Bay) than in the other basins of the lake, as a result of the higher watershed nutrient loading and higher phosphorus concentrations in the water there, as well as the higher level of phytoplankton activity in

the water of Basin I. Fluctuations of turnover time within individual seasons, as well as the seasonal differences in this parameter for phytoplankton-P, DIP, and DOP, all increase on moving from Basin I to Basin IV. During the summer months, daily variations in turnover time are much less pronounced than in other seasons. From year to year some seasonal differences in the phosphorus cycle could be observed on examining the monthly mean turnover times for individual compartments in each basin, but the annual mean values indicate that approximately similar environmental and phosphorus loading conditions persisted throughout the four-year study period.

Finally, the response of the lake to changes in phosphorus load was estimated in model runs using information on water temperature, solar radiation, and water balance, averaged over several years. The expected in-lake concentration of each of the major phosphorus compartments was computed on the basis of various possible phosphorus loads from what was considered to be the major controllable source, namely the Zala river. These data were then generalized as simple correlation equations describing the seasonal and annual phosphorus levels as functions of phosphorus loadings. Phosphorus flows along the individual transformation pathways considered in the BALSECT model were also evaluated as simple functions of the input loads from the Zala river.

PREFACE

Man-made eutrophication has emerged over the past 10–20 years as perhaps the single most serious water-quality problem affecting lakes. Increasing discharges of wastewater and the intensive use of agricultural fertilizers are among the major causes of this undesirable phenomenon. The symptoms of eutrophication – including sudden algal blooms, water discoloration, dead fish, and the excretion of toxic substances – can place severe limitations on the use of lake water for domestic, agricultural, industrial, and recreational purposes, and may reduce the economic and environmental value of the lake-shore region.

The eutrophication of deep lakes is better understood than that of shallow lakes, which exhibit much more irregular behavior. Comprehensive research into the problems of shallow lakes is also necessary because of the great economic importance of these lakes and their surrounding regions, particularly in Europe. These factors led IIASA's Resources and Environment Area to initiate a research project on the man-made eutrophication of shallow lakes. This project began in 1978 and the work was completed in 1982.

One of the largest shallow lakes in the world, Lake Balaton in Hungary, was already at that time showing unfavorable symptoms of man-made eutrophication, and it was selected for a major IIASA case study. Several reasons lay behind this decision. Lake Balaton is in many respects a "typical" shallow lake and a significant amount of scientific data was available even at the beginning of the study. There had also already been considerable research and practical work on the problem within Hungary. Moreover, serious economic interests were associated with a successful solution to the problem of lake eutrophication, particularly as Balaton is the major recreational area in Hungary. Thus, the problem facing Lake Balaton raised important scientific *and* practical questions and offered the possibility of deriving general conclusions that might well be of value elsewhere.

From the Hungarian side, there was active participation in the cooperative IIASA study from various research institutes of the Hungarian Academy of Sciences and the Hungarian National Water Authority. In addition to the permanent contribution of IIASA staff members, a number of collaborative links were established through IIASA to outside experts and to institutes such as MIT, the Twente University of Technology, and the Computer Center of the USSR Academy of Sciences.

A number of groups of topics made up the research agenda for the project. Nutrient loads and watershed development, sediments and their interaction with the water, and the biochemical and biological processes in the lake (dynamics of phosphorus, nitrogen, and phytoplankton; phosphorus and nitrogen metabolism; etc.) were examined in detail. The role of water circulation and mass transport in eutrophication and the influence of stochastic environmental factors (both controllable and uncontrollable) were studied, while special attention was paid to data collection and the impacts of various uncertainties. *In situ* and laboratory experiments and mathematical models were employed in the study. Most of the

information was built into the lake eutrophication model, describing spatial and temporal changes in water quality. On a more macroscopic level, the planning-type eutrophication management model was used to determine the "optimal" control strategy in light of the given dynamic processes, stochastic effects, control alternatives, costs, and other constraints specified.

From a methodological point of view, the study covered a wide range of individual techniques (and combinations thereof), including the method of finite differences and finite elements for hydrodynamic modeling, parameter estimation and model structure identification procedures (for example, Kalman filtering), methods for analyzing uncertainty (Monte Carlo simulation and others), and various optimization methods.

IIASA's work was perhaps broader in scope than other water-quality studies, since it covered in an integrated manner disciplines ranging from biochemistry to economics, all of which are in some way related to man-made eutrophication. However, this breadth was complemented wherever necessary by in-depth expertise in individual disciplines through the participation of a number of Hungarian research institutes.

The study provided answers to several scientific questions related to the eutrophication of shallow lakes. But a number of other questions remained – at least partially – unresolved and further gaps were discovered in the existing research. The role of sediments and the prediction of structural ecosystem changes are perhaps of particular importance in this respect.

The Lake Balaton study has had a definite impact on policy making. In the course of 1982 recommendations were prepared for the Hungarian government on how to revise and modify the existing "management action plan" for water quality control and regional development. The "optimal" control strategy developed in the study and other conclusions derived from the work were especially helpful in elaborating these recommendations, which were approved by the Hungarian Council of Ministers in January 1983.

The present report by Alexander Leonov describes one part of the report, analyzing the lake's phosphorus cycle and phosphorus dynamics. The BALSECT model is one of a number of alternative biochemical models developed for Lake Balaton. Readers interested in a summary of the research related to Lake Balaton are referred to L. Somlyody, S. Herodek, and J. Fischer (Eds.), *Eutrophication of Shallow Lakes: Modeling and Management. The Lake Balaton Case Study*, published by IIASA as Collaborative Proceedings CP-83-S3.

LASZLO SOMLYODY
Leader, 1980-82
Lake Balaton Case Study

MODELING AND EXPLAINING THE PHOSPHORUS DYNAMICS OF LAKE BALATON, 1976–1979

Alexander Leonov

*International Institute for Applied Systems Analysis,
Laxenburg, Austria and Institute of Water Problems,
Academy of Sciences of the USSR, Moscow, USSR*

1. INTRODUCTION

This report presents a mathematical modeling and systems approach to the study of the eutrophication problem in Lake Balaton, Hungary. Since it is generally agreed that phosphorus exerts a major influence on the direction of trophic change within the lake, the work described here focuses on the dynamics of the phosphorus level in the lake ecosystem over the period 1976–1979. The research was carried out within the framework of the Lake Balaton Case Study at the International Institute for Applied Systems Analysis (IIASA), whose principal goal was to develop mathematical models at various levels of sophistication and complexity to describe phosphorus transformation and the general question of water-body eutrophication. This report describes the results obtained using BALSECT (the Balaton Sector Model), which is one of three ecological models developed at IIASA for examining phosphorus dynamics and phytoplankton growth in the Lake Balaton ecosystem. BALSECT simulates the basic biological and chemical interactions between phosphorus compartments in the aquatic environment, as well as considering sediment–water phosphorus exchange and horizontal interbasin phosphorus transfer by advective and wind-induced water flows.

A detailed description of BALSECT has been given elsewhere (Leonov 1980), so that only a brief review of its main features and nomenclature is presented here. Other preliminary papers have reported the results of applying BALSECT to reproducing and analyzing the phosphorus dynamics in different parts of Lake Balaton over the period 1976–1978, assessing the role of sediment in the phosphorus balance, studying the model's sensitivity to changes in environmental factors such as temperature, radiation, and nutrient loading, and evaluating the turnover-time values for individual phosphorus compartments (Leonov 1981a, 1982).

During 1980 and 1981, great efforts were made by our Hungarian colleagues in the quantitative assessment of the influence of the watershed area on Lake Balaton eutrophication. As a consequence of these studies, an improved version of the watershed phosphorus load model was developed toward the end of 1981; this was

used in the final stage of the Lake Balaton Case Study and is the version described here. Simulations of the phosphorus dynamics in different parts of the lake were performed for the period 1976–1979.

The study addressed five specific topics. First, we assessed the adequacy of the model by means of statistical tests. Second, the phosphorus flows, external and internal, in the Lake Balaton ecosystem were analyzed. Third, we made quantitative estimates of the role of sediment in overall phosphorus dynamics and in the phosphorus balance between major compartments. Fourth, the dynamics and mean values of turnover times for the phosphorus compartments actually modeled were evaluated. Finally, we carried out simulations of phosphorus load changes, in order to assess the responses of the lake and to identify simple correlations between phosphorus loading and concentrations of major phosphorus fractions in the lake water as well as internal phosphorus flows within the system.

2. THE MODEL

Because it was agreed that phosphorus is the key element in Lake Balaton eutrophication, the phosphorus transformation model BALSECT was selected for the study. This model includes interactions between five phosphorus compartments, namely inanimate particulate organic-P (PD), dissolved organic-P (DOP), bacterial-P (B), dissolved inorganic-P (DIP), and phytoplankton-P (F), as shown in Figure 1. In general terms, BALSECT considers those processes that have particular importance in the phosphorus cycle and phytoplankton growth:

- (i) *Phytoplankton production and nutrient uptake*, which are dependent on temperature and light conditions as well as DIP content;
- (ii) *Bacterial production*, which is temperature dependent and an important step in DOP transformation and DIP regeneration;
- (iii) *Metabolic excretion of DOP and DIP*, by phytoplankton and bacteria, respectively;
- (iv) *Nonpredatorial mortality of phytoplankton and bacteria*, as essential mechanisms in the phosphorus cycle in the aquatic environment;
- (v) *Decomposition of inanimate particulate organic-P*, which is an important stage in phosphorus transformation and in the release of chemical energy stored in detritus;
- (vi) *Phosphorus exchange through the sediment–water interface*, which includes the resuspension–sedimentation of inanimate particulate organic-P and the release of dissolved inorganic-P from the sediments.

The model considers these processes for each of four specific basins of Lake Balaton, namely Keszthely Bay (I), Szigliget (II), Szemes (III), and Siófok (IV), of which Basin I (Keszthely Bay) represents the most polluted area of the lake (van Straten *et al.* 1979).

Full details of the nomenclature used in BALSECT are given in the Appendix. The general form of the model expression, written as an ordinary differential equation, is

$$\frac{dC_{i,j}}{dt} = R_{i,j} + LOAD_{i,j} + TR_{i,j} \quad (1)$$

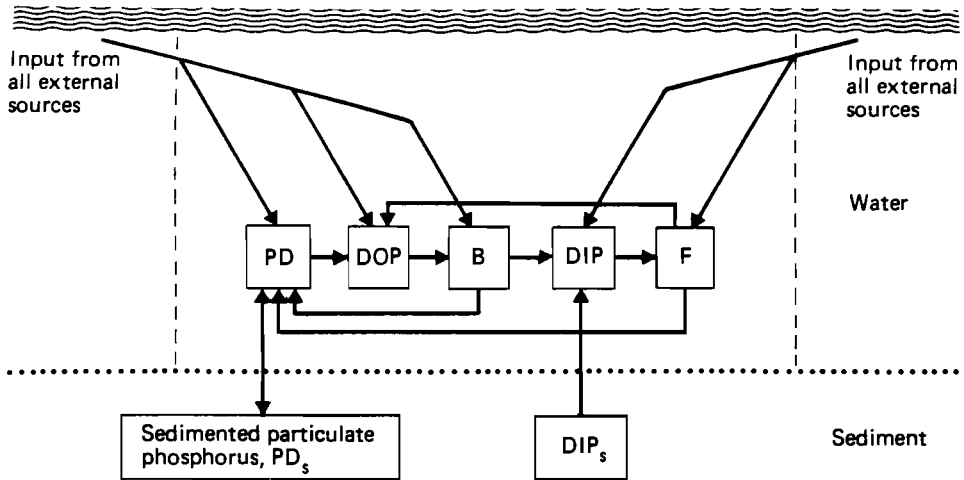

FIGURE 1 Diagram of the phosphorus compartment interactions considered in the BALSECT model.

Rates of biochemical transformations of the individual phosphorus fractions ($R_{i,j}$) in each of the basins are given by the following equations

$$\text{for PD: } i = 1 \quad R_{PD_j} = M_{F_j} \cdot F_j + M_{B_j} \cdot B_j - K_3 \cdot PD_j - S_j \quad (2)$$

$$\text{for DOP: } i = 2 \quad R_{DOP_j} = K_3 \cdot PD_j + L_{F_j} \cdot F_j - UP_{B_j} \cdot B_j \quad (3)$$

$$\text{for B: } i = 3 \quad R_{B_j} = (UP_{B_j} - L_{B_j} - M_{B_j}) \cdot B_j \quad (4)$$

$$\text{for DIP: } i = 4 \quad R_{DIP_j} = L_{B_j} \cdot B_j - UP_{F_j} \cdot F_j \quad (5)$$

$$\text{for F: } i = 5 \quad R_{F_j} = (UP_{F_j} - L_{F_j} - M_{F_j}) \cdot F_j \quad (6)$$

The equations used in the model to describe microorganism functions – nutrient uptake, metabolite excretion, and nonpredatorial mortality – plus those for detritus decomposition and sedimentation, are shown in Table 1.

The phosphorus load term ($LOAD_{i,j}$) takes into account the following sources: atmospheric pollution for DIP, DOP, and PD, sewage load for DIP, and urban runoff, tributary, and sediment loads for DIP and PD. For the individual phosphorus compartments the loading terms are as follows

$$\text{for PD: } i = 1 \quad LOAD_{PD_j} = PD_z \cdot (\gamma_{1_j} + \gamma_{2_j}) \cdot (V_1/V_j) + PD_r \cdot (4.3/d_j)^2 \cdot W^U + C_{PD}^r \cdot (Q_{pr_j}/V_j) \quad (7)$$

$$\text{for DOP: } i = 2 \quad LOAD_{DOP_j} = C_{DOP}^r \cdot (Q_{pr_j}/V_j) \quad (8)$$

$$\text{for DIP: } i = 3 \quad LOAD_{DIP_j} = C_{DIP}^r \cdot (Q_{pr_j}/V_j) + DIP_z \cdot (y_{1_j} + y_{2_j}) \cdot (V_1/V_j) + CZ_{DIP_j} + DIP_r \cdot \exp(K_{tr} \cdot T) \cdot W \quad (9)$$

The interbasin horizontal transport ($TR_{i,j}$) of the phosphorus fractions is considered in the model as the result of two prevailing mechanisms, namely net hydrological transport and transport by wind-induced water flow. The general expression for the transport term is written as

TABLE 1 Model equations used to describe ecological processes in Lake Balaton.

Ecological process	Main equation	Additional terms
1. Microorganism growth		
• phytoplankton	$UP_{F_j} = \frac{K_1 \cdot R_{TF} \cdot R_{IF}}{1 + F_j / (\beta \cdot DIP_j)}$	$R_{IF} = (e / K_e \cdot h) [\exp(-r_x) - \exp(-r_1)]$ $r_1 = I / I_{opt}$ $r_x = r_1 \exp(-K_e \cdot h) $ $K_e = K_a + K_b \cdot (\mu g \text{ chlorophyll } l^{-1})$ $I = I_{max} \cdot h \cdot \left[1 + \cos \frac{2\pi(t_n - t_p)}{f} \right]$ $I_{max} = 2 \cdot I_{av} / f$ $R_{TF} = 0.2 + \frac{0.022 \cdot (e^{0.21 \cdot T} - 1)}{1 + 0.028 \cdot e^{0.21 \cdot T}}$ $R_{TB} = 0.3 + \frac{3.68 \cdot 10^{-3} (e^{0.403 \cdot T} - 1)}{1 + 5.25 \cdot 10^{-3} e^{0.403 \cdot T}}$
• bacteria	$UP_{B_j} = \frac{K_2 \cdot R_{TB}}{1 + B_j / DOP_j}$	
2. Microorganism metabolic excretion		
• phytoplankton	$L_{F_j} = r_{F_j} \cdot UP_{F_j}$	$r_{F_j} = \frac{(\alpha_1 / \alpha_2) \cdot UP_{F_j}}{(1 / \alpha_2) + UP_{F_j}} + (1 - \alpha_1 / \alpha_2)$
• bacteria	$L_{B_j} = r_{B_j} \cdot UP_{B_j}$	$r_{B_j} = \frac{(\alpha_3 / \alpha_4) \cdot UP_{B_j}}{(1 / \alpha_4) + UP_{B_j}} + (1 - \alpha_3 / \alpha_4)$
3. Microorganism mortality		
• phytoplankton	$M_{F_j} = v_1 \cdot F_j / UP_{F_j}$	
• bacteria	$M_{B_j} = v_2 + v_3 \cdot B_j / UP_{B_j}$	
4. Temperature-dependent rate of detritus decomposition	$K_3 = \frac{1.2 \cdot 10^{-4} (e^{0.351 \cdot T} - 1)}{1 + 3.0 \cdot 10^{-4} e^{0.351 \cdot T}}$	
5. Detritus sedimentation	$S_j = K_{sed} \cdot (4.3 / d_j) \cdot PD_j$	

$$\begin{aligned}
TR_{i,j} = & C_{i,j-1} \cdot (Q_{in,j} + Q_{win,j}^a) / V_j - C_{i,j} \cdot (Q_{out,j} + Q_{wout,j}^b) / V_j \\
& - C_{i,j} \cdot (Q_{wout,j}^a) / V_j + C_{i,j+1} \cdot (Q_{win,j}^b) / V_j
\end{aligned} \tag{10}$$

The rate of wind-induced flow that brings about phosphorus exchange through the interbasin cross-sections is calculated on the basis of wind data using the equation

$$Q_w = \text{abs} | k \cdot W \cdot A_j \cdot \cos(\tau - 30) | \tag{11}$$

Equations (1)–(11), together with those presented in Table 1, provide a complete description of the structure of the BALSECT model. Detailed explanations of the model equations have been given elsewhere (Leonov 1980, 1982).

3. THE DATA BASE

Once again, we present here only a relatively brief description of the data used in the study. van Straten *et al.* (1979) reviewed at some length the data available for Lake Balaton.

The data used in the study can be subdivided into three distinct groups:

- (i) Physical, meteorological, and hydrological data;
- (ii) Nutrient loading data;
- (iii) Observed phosphorus, nitrogen, and phytoplankton levels in different areas of the lake.

The first group of data contains daily mean values of the water temperature and solar radiation, and three-hour measurements of wind directions and speeds. It also includes water balance data, comprising daily measurements of the discharge flow rates of the Zala river, monthly average input and output flow rates, and precipitation rates for the different basins of the lake. All the data from the first group are used as factors regulating the rates of biochemical phosphorus conversion in the aquatic environment in the simulation of the lake's phosphorus dynamics.

The second group of data comprises nutrient loads from the following sources: Zala river discharge water, urban runoff, sewage, tributaries, rainfall, and sediments. In the water discharged by the Zala river, concentrations of total phosphorus and dissolved orthophosphate-phosphorus were measured daily. Measurements of chlorophyll-a in the Zala river discharge water were performed at irregular intervals over the same period, 1976–1979, and then converted into the equivalent phytoplankton phosphorus levels. The concentration of bacterial phosphorus in the Zala river water was assumed to be constant throughout the period studied and equal to $4 \times 10^{-4} \text{ mg P l}^{-1}$, while the DOP concentration, due to a lack of data, was assumed to be negligibly low (Leonov 1980). The concentration of inanimate particulate organic phosphorus in water discharged to the lake from the Zala river is calculated as the difference between total phosphorus and the levels of all other phosphorus forms, DIP, F, and B.

The rainfall load takes into account phosphorus inputs in the form of DIP, DOP, and PD. The concentrations of these phosphorus fractions in the rainfall were assumed to be constant for the period 1976–1979 and equal to 0.04, 0.06, and

0.08 mg P l⁻¹, respectively. Together with the water balance information, these phosphorus loading data were used in the simulation runs where they quantitatively account for the direct influence of the Zala river and atmospheric precipitation on phosphorus circulation in Lake Balaton.

The influence of sewage as a DIP source was also taken into consideration in this study. Table 2 shows the rates of sewage DIP load averaged for each month of the year. These rates, which were assumed to be similar for each year within the period 1976–1979, were evaluated on the basis of assumptions about the four-basin extrapolation of the Zala river DIP load and the time distribution of the sewage DIP load (Jolankai and Somlyody 1981). These rates take into account monthly variations in both the direct sewage load and the mixed sewage load that relates to the annual average values.

TABLE 2 Monthly average values of sewage DIP loading (mg P l⁻¹ day⁻¹) used in the simulation runs.

Month	Basin			
	I	II	III	IV
January	0.00002	0.00001	0.00014	0.00007
February	0.00002	0.00001	0.00014	0.00007
March	0.00002	0.00001	0.00014	0.00007
April	0.00002	0.00001	0.00014	0.00007
May	0.00004	0.00002	0.00002	0.00014
June	0.00004	0.00002	0.00002	0.00014
July	0.00006	0.00003	0.00003	0.00021
August	0.00006	0.00003	0.00003	0.00021
September	0.00004	0.00002	0.00002	0.00014
October	0.00002	0.00001	0.00035	0.00007
November	0.00002	0.00001	0.00014	0.00007
December	0.00002	0.00001	0.00014	0.00007

In later stages of the study, the inputs of DIP and PD from all tributaries and urban runoff were also incorporated. These inputs were considered to be proportional to that from the Zala river, based on the hypothesis of a longitudinal distribution of nonpoint sources over the four basins of Lake Balaton (from Keszthely Bay to Siófok), as discussed by van Straten and Somlyody (1980) and Jolankai and Somlyody (1981). The values of the tributary phosphorus-load coefficients γ_1 (particulate-P) and ν_1 (DIP) are shown in Table 3. These coefficients were assumed to be similar for each year in the period studied.

The urban-runoff load coefficients are calculated in two steps. In the first step, estimates of the particulate-P and DIP loads for the Zala river and for the lake as a whole are used to calculate the ratios R_1 and R_2 , as shown in Table 4. The numbers 210 and 29 represent, respectively, the average PD and DIP loads in kg day⁻¹. In the second step, R_1 and R_2 are used to calculate the final urban-runoff phosphorus load coefficients, γ_2 and ν_2 , as shown in Table 5. The values of the coefficients γ_1 , γ_2 , ν_1 , and ν_2 presented in Tables 3 and 5 are incorporated in the phosphorus load terms in eqns. (7) and (9).

The sediments represent an additional source of nutrients. The time-averaged flux of DIP from lake sediments, evaluated on the basis of field measurements, was assumed to be equal to 1.45×10^{-5} , 0.52×10^{-5} , 0.42×10^{-5} , and

TABLE 3 Proportionality coefficients describing tributary phosphorus loading used in the simulation runs.

Coefficient		Basin			
		I	II	III	IV
γ_1	Particulate-P	1.0	0.71	0.42	0.06
y_1	DIP	1.0	0.80	0.17	0.03

TABLE 4 Ratios R_1 and R_2 used in the calculation of urban runoff load coefficients, based on annual Zala river loads.

Year	Particulate-P load PD_Z (kg day ⁻¹)	R_1 (210 / PD_Z)	DIP load DIP_Z (kg day ⁻¹)	R_2 (29 / DIP_Z)
1976	81	2.593	69	0.4200
1977	129	1.628	86	0.3372
1978	115	1.826	105	0.2762
1979	176	1.190	128	0.2260

TABLE 5 Final values of the urban runoff phosphorus load coefficients γ_2 and y_2 used in the simulation runs.

Basin	Proportionality coefficient for urban runoff load ^a	Particulate-P coefficient (γ_2)				DIP coefficient (y_2)			
		1976	1977	1978	1979	1976	1977	1978	1979
I	0.10	0.2593	0.1628	0.1826	0.1190	0.0420	0.0337	0.0276	0.0226
II	0.24	0.6223	0.3909	0.4384	0.2859	0.1010	0.0808	0.0662	0.0540
III	0.30	0.7779	0.4883	0.5474	0.3569	0.1263	0.1007	0.0832	0.0679
IV	0.36	0.9335	0.5862	0.6578	0.4284	0.1510	0.1216	0.0990	0.0814

^aThe proportion of urban runoff load associated with each basin of the lake.

0.33×10^{-5} mg P l⁻¹ day⁻¹ for Basins I, II, III, and IV, respectively. The time-averaged flux of inanimate particulate-P from the sediment to the water was taken as 7×10^{-4} mg P l⁻¹ day⁻¹ for all four basins during the years 1976–1979. It should be noted that the actual phosphorus fluxes from the sediment to the water are considered in this model to be dependent on environmental factors, so that the resuspension of inanimate particulate-P is regulated by wind, while sediment-DIP release is controlled by temperature and wind conditions.

The third group of data includes direct measurements of phosphorus compartments in the four basins of Lake Balaton. The fractions directly measured are orthophosphate-P (PO₄), which is considered to be equivalent to DIP,* total dissolved phosphorus (TDP), particulate inorganic phosphorus (PIP)** and total phosphorus (TP). The concentrations of other phosphorus components that are

*There is insufficient quantitative information for the lake to consider DIP and PO₄ as individual fractions.

**PIP is not taken into account in the BALSECT model.

important when considering the behavior of the phosphorus system can be calculated from those directly measured:

- (i) Dissolved organic phosphorus: $DOP = TDP - PO_4$;
- (ii) Particulate phosphorus: $PP = TP - TDP$;
- (iii) Particulate organic phosphorus: $POP = PP - PIP$.

The data from the third group were only used for comparisons with the simulation results for the period 1976–1979. Because of the varying numbers of sampling stations in the different basins of Lake Balaton (van Straten *et al.* 1979), the average concentrations of the phosphorus compartments mentioned above were calculated separately for each basin.

4. THE SIMULATIONS

The BALSECT mathematical model described above, formulated as a set of ordinary differential equations, was coded in FORTRAN and implemented on IIASA's VAX 11/780 computer. The model equations were solved numerically using the Runge–Kutta-4 procedure and a time step of 0.1 days.

The initial values of the phosphorus compartment concentrations for the simulation runs were taken from the Lake Balaton observation file available at IIASA. These concentrations correspond to the observed environmental conditions of January 1, 1976 and they are shown in Table 6. Values of all the rate coefficients used in the model were determined earlier, during a model application to simulate phosphorus transformation in the different parts of Lake Balaton under the observed environmental conditions of 1977 (Leonov 1980). However, in the present work similar values of rate coefficients were used to simulate the phosphorus dynamics in all of the basins of Lake Balaton, in contrast to earlier studies (Leonov 1980, 1981a) where phytoplankton activity was assumed to decrease from Keszthely Bay to the Siófok basin. Thus it was assumed that only the structure of phosphorus inputs from external sources in the watershed and the internal phosphorus circulation within the water body were important in determining phytoplankton growth and phosphorus levels in the different areas of the lake. The values of the rate coefficients used in this part of the study are shown in Table 7.

TABLE 6 Initial concentrations (mg P l^{-1}) of the phosphorus compartments used in the simulations.

Phosphorus compartment	Symbol	Basin			
		I	II	III	IV
Dissolved inorganic phosphorus	DIP	0.0020	0.0020	0.0015	0.0010
Dissolved organic phosphorus	DOP	0.0050	0.0100	0.0050	0.0040
Phytoplankton phosphorus	F	0.0050	0.0030	0.0025	0.0020
Bacterial phosphorus	B	0.0010	0.0008	0.0007	0.0006
Inanimate particulate organic phosphorus	PD	0.0100	0.0040	0.0030	0.0020

TABLE 7 Values of rate coefficients and other model parameters used in the simulation runs.

Parameter	Symbol	Unit	Value
Maximum uptake rate for phytoplankton	K_1	day ⁻¹	2.3 at 20°C
Excretion efficiency for phytoplankton	$\left\{ \begin{array}{l} \alpha_1 \\ \alpha_2 \end{array} \right.$	day day	0.057 0.075
Phytoplankton mortality as a function of biomass and nutrient content of water	ν_1	(mg P l ⁻¹) ⁻¹ day ⁻²	0.2
Coefficient of substrate conversion by phytoplankton	β	dimensionless	0.6
Maximum uptake rate for bacteria	K_2	day ⁻¹	0.3 at 20°C
Excretion efficiency for bacteria	$\left\{ \begin{array}{l} \alpha_3 \\ \alpha_4 \end{array} \right.$	day day	0.3 0.45
Natural bacterial mortality	ν_2	day ⁻¹	0.053
Bacterial mortality as a function of biomass and nutrient content of water	ν_3	(mg P l ⁻¹) ⁻¹ day ⁻²	1.0
Detritus decomposition rate	K_3	day ⁻¹	0.1 at 20°C
Extinction coefficient	$\left\{ \begin{array}{l} K_a \\ K_b \end{array} \right.$	m ⁻¹ m ⁻¹ ($\mu\text{g Chl l}^{-1}$) ⁻¹	1.7 0.0088
Rate constant of detritus sedimentation	K_{sed}	day ⁻¹	0.25
Rate constant of phosphorus transformation in sediments	K_{tr}	day ⁻¹	0.125
Empirical coefficient for the dependence of detritus resuspension on wind speed	U	dimensionless	1.0
Proportionality transport coefficient of wind-induced water flow	k	dimensionless	0.0018
Ratio of phytoplankton-P to chlorophyll-a	α	mg P ($\mu\text{g Chl}$) ⁻¹	0.00047

Together with the data on environmental factors and phosphorus loads discussed above, the input data in Tables 6 and 7 made it possible to simulate the phosphorus dynamics of the lake for the four-year period 1976–1979. A comparison of the simulated and observed phosphorus-concentration dynamics for the individual basins of Lake Balaton over this period is shown separately in Figures 2–6 for particulate organic-P (that is, the sum of phytoplankton-P, bacterial-P, and PD), DIP, DOP, total dissolved P, and total P, respectively. All observed phosphorus levels are plotted in the figures as arithmetic means, with the indicated range of fluctuations from minimum to maximum in the measured phosphorus concentrations from the different sampling stations within Basins II, III, and IV. As regards Basin I (Keszthely Bay), since there was only one sampling station in this area, the expected range of analytical error in the phosphorus measurements was assumed to be $\pm 10\%$, as indicated in Figures 2–6.

Another form of data obtained in the simulation is given in Table 8, namely, seasonal and annual mean phosphorus concentrations, and standard deviations of these means, for each basin and year studied. This method of presenting the simulation results is particularly convenient for the comparison of the various ecological models, such as BEM (the Balaton Eutrophication Model), SIMBAL (the Simple Balaton Model), and BALSECT, developed at IIASA and applied in the study of the Lake Balaton ecosystem.

The simulation results presented in Figures 2–6 and Table 8 permit quantitative estimates to be made of the basic trends in phosphorus compartment concentration changes that took place in different areas of Lake Balaton during 1976–1979 as a consequence of environmental fluctuations and varying phosphorus inputs from the external sources taken into account in the study.

5. THE ADEQUACY OF THE MODEL

BALSECT was developed to provide an acceptable description of the behavior of phosphorus compartments and to gain insight into how the lake ecosystem operates. Therefore an analysis of the adequacy of the model formed an important part of the research.

A preliminary analysis, on the basis of a number of statistical methods, was reported earlier (Leonov 1981a). In the present work a similar analysis was made to compare the phosphorus observations available for Lake Balaton with the simulation results obtained using the improved representation of external phosphorus loadings for 1976–1979.

Three statistical tests were used for this purpose. In the first, all the phosphorus data available for individual phosphorus compartments are combined to obtain statistically significant results and the variances calculated for both samples – observations and modeling results – are compared. Then a measure of the model error (M_e) is calculated using the formula

$$M_e = (\sigma_e^2 / \sigma_d^2) \cdot 100\% \quad (12)$$

where σ_e and σ_d are standard deviations for the simulated and observed samples, respectively, derived from the relations

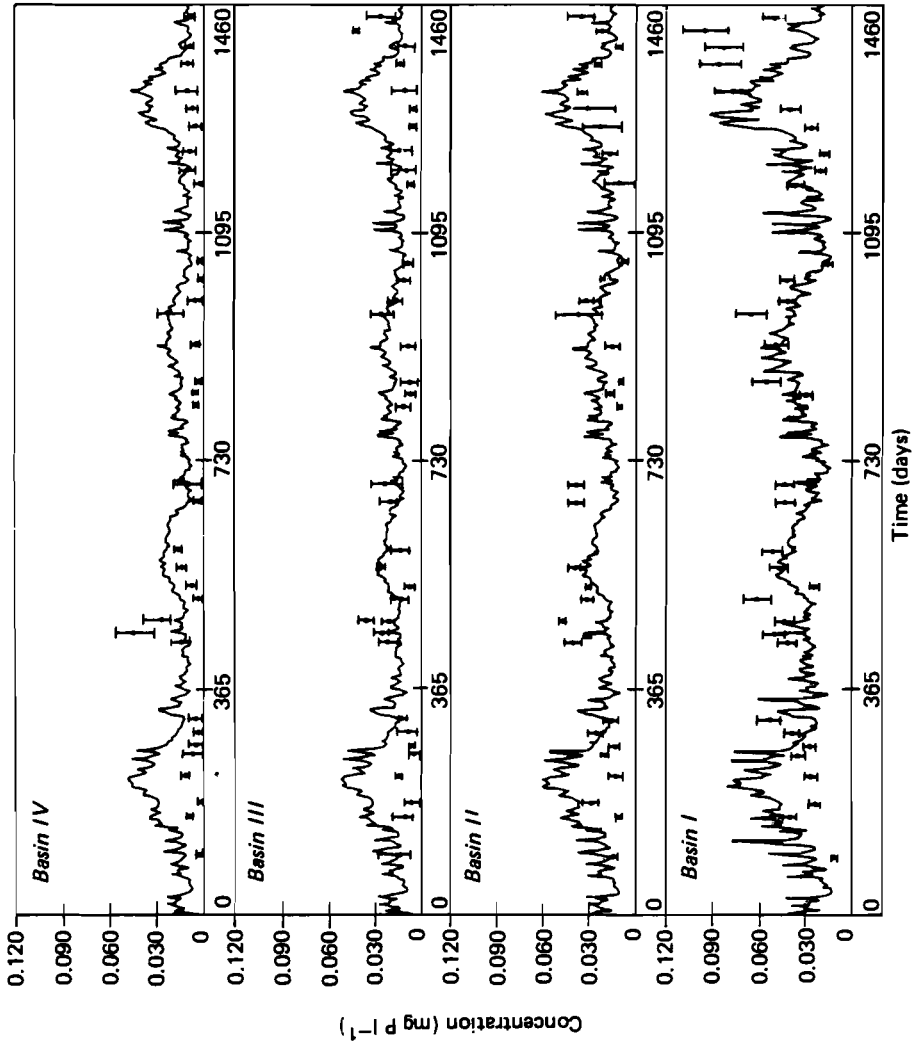

FIGURE 2 Comparison of model calculations (curves) and observed data for particulate organic phosphorus, Lake Balaton Basins I-IV, 1976-1979.

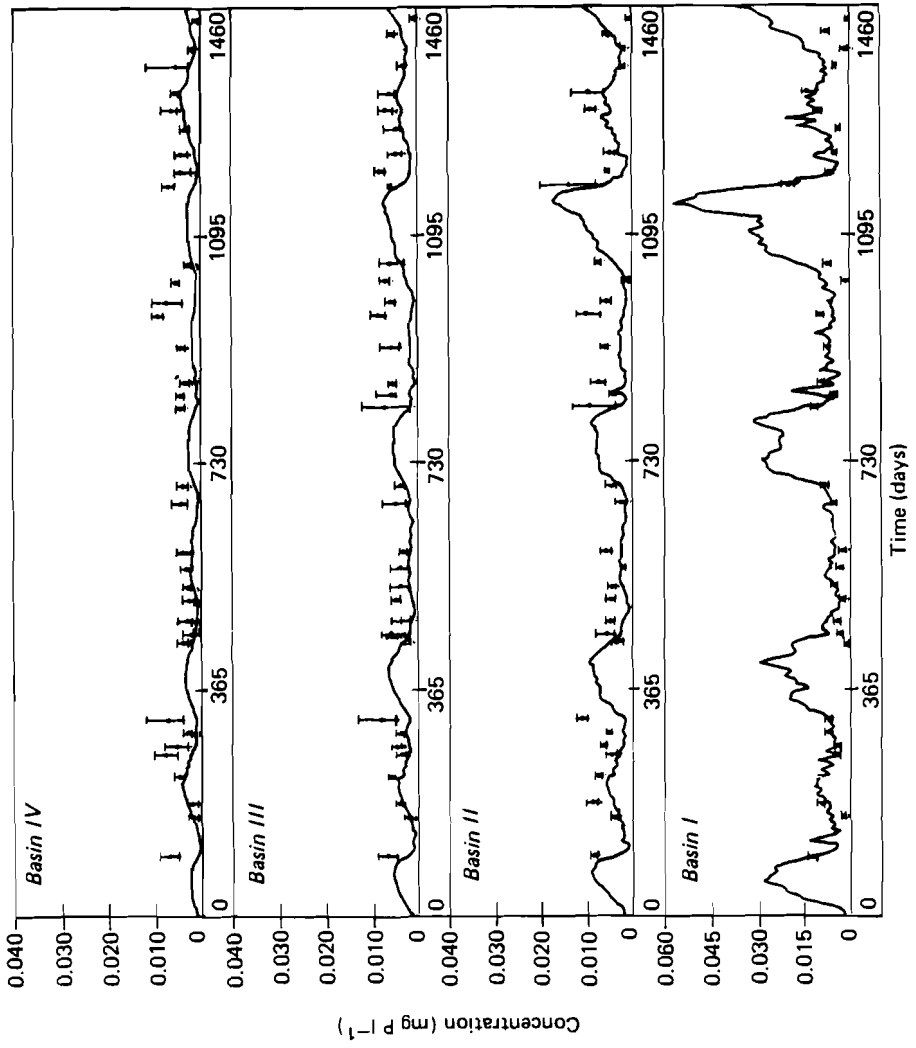

FIGURE 3 Comparison of model calculations (curves) and observed data for dissolved inorganic phosphorus, Lake Balaton Basins I-IV, 1976-1979.

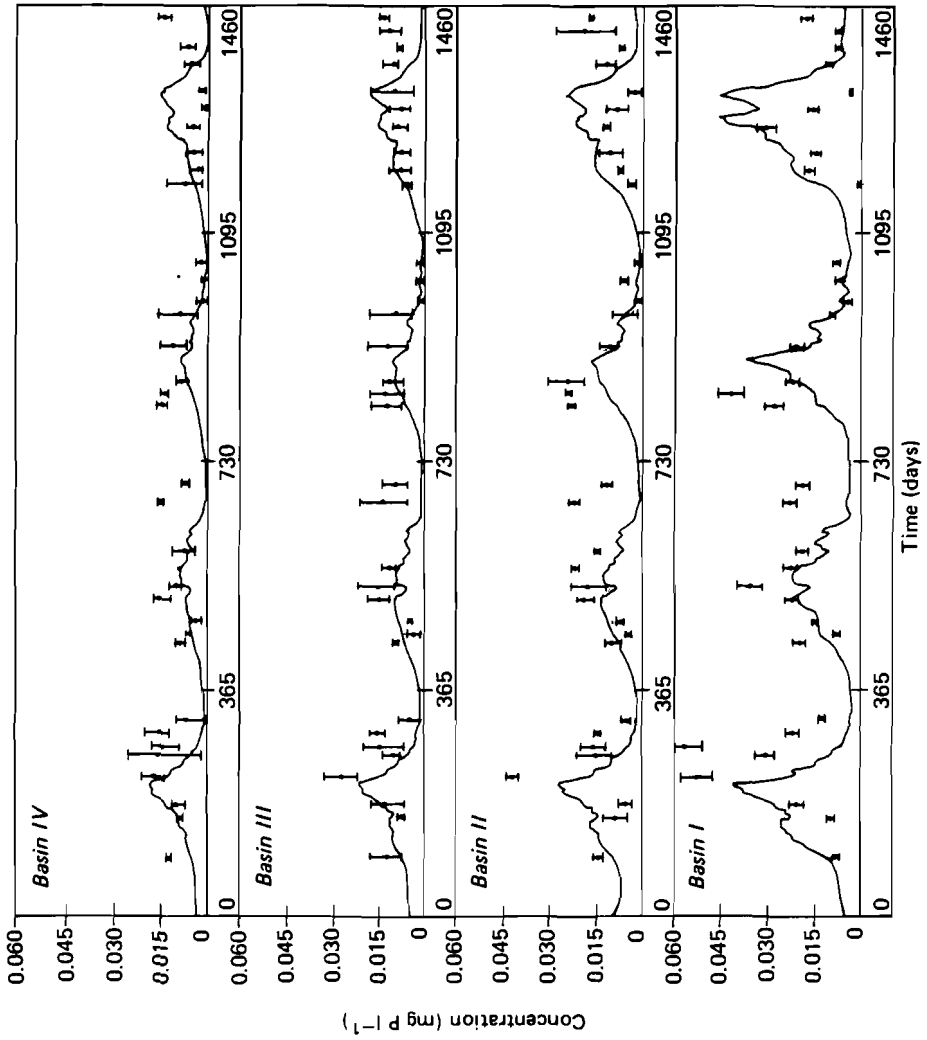

FIGURE 4. Comparison of model calculations (curves) and observed data for dissolved organic phosphorus, Lake Balaton Basins I-IV, 1976-1979.

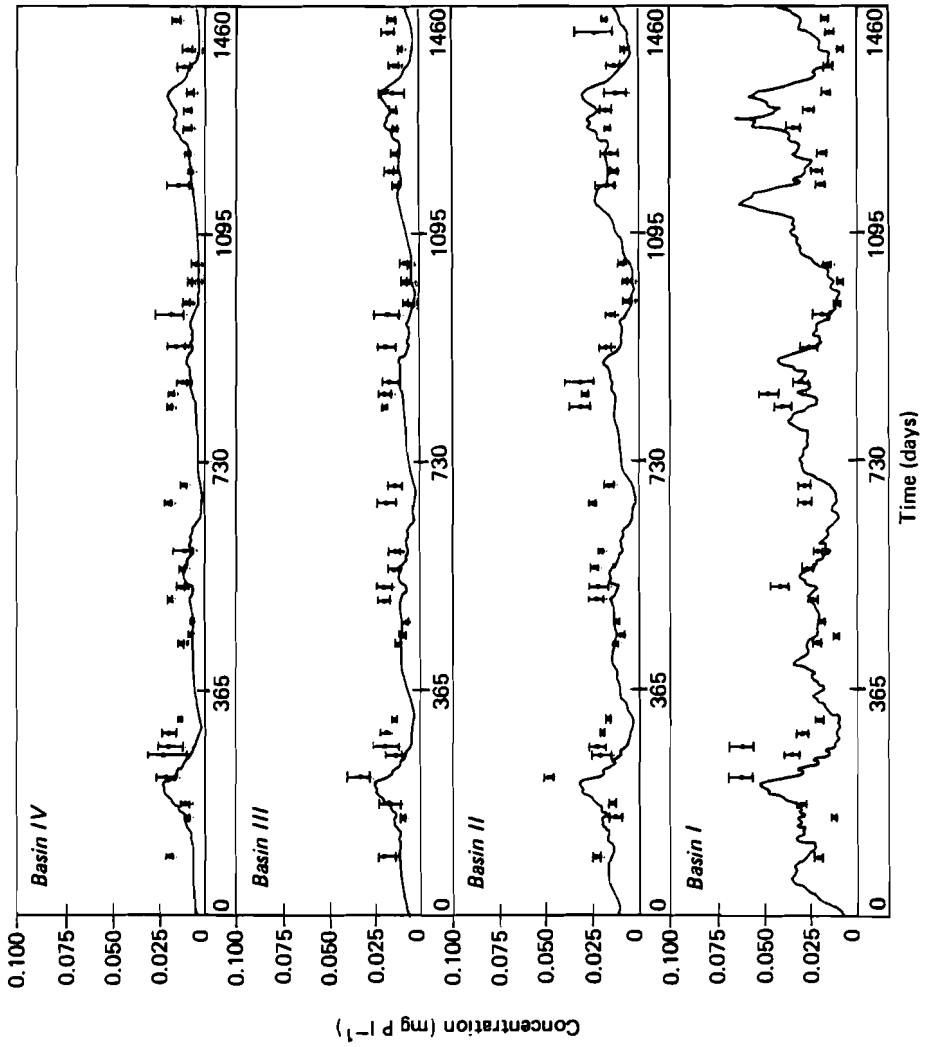

FIGURE 5 Comparison of model calculations (curves) and observed data for total dissolved phosphorus, Lake Balaton Basins I-IV, 1976-1979.

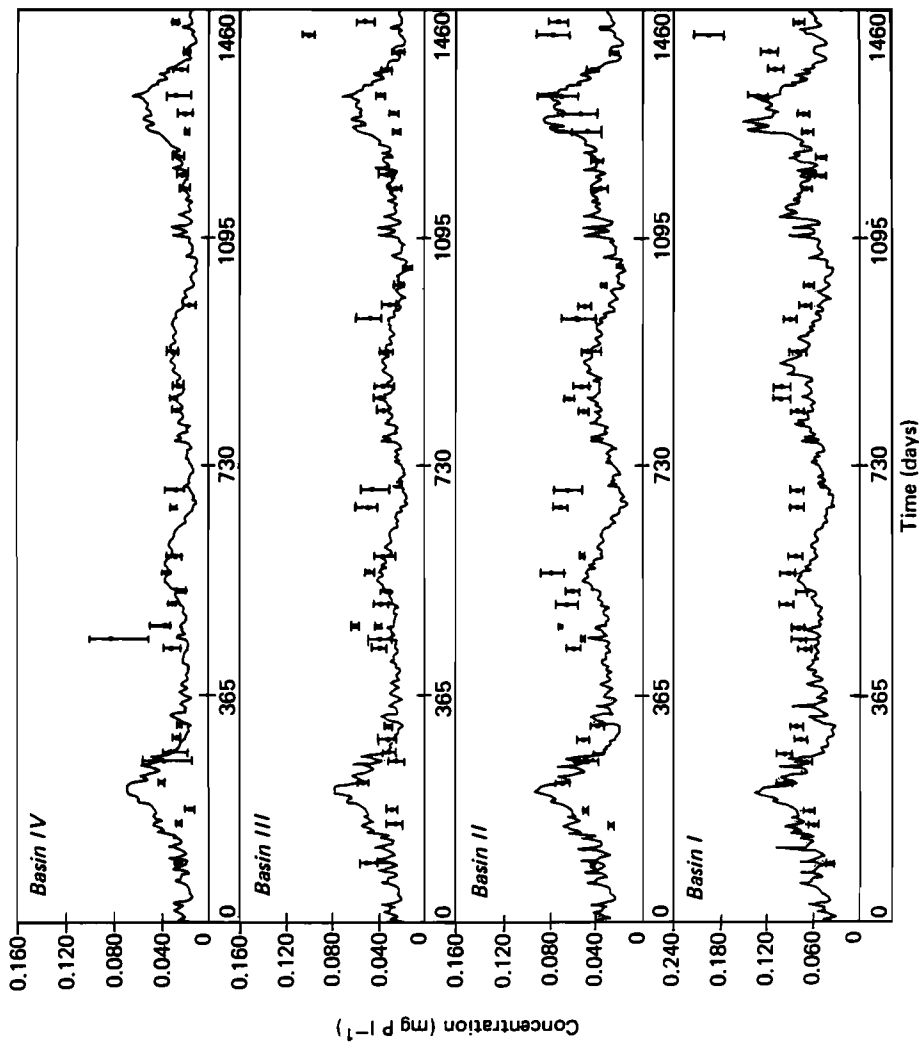

FIGURE 6 Comparison of model calculations (curves) and observed data for total phosphorus, Lake Balaton Basins I-IV, 1976-1979.

TABLE 8 Simulation results for Lake Balaton, 1976–1979: seasonal and annual mean phosphorus concentrations (μ) and standard deviations (σ), all in $\mu\text{g P l}^{-1}$.

Year	Basin	Form of phosphorus	Winter, Jan–Mar		Spring, Apr–Jun		Summer, Jul–Sep		Autumn, Oct–Dec		Annual	
			μ	σ	μ	σ	μ	σ	μ	σ	μ	σ
1976	I	DIP	18.2	8.4	8.0	3.0	8.8	2.0	10.9	5.4	11.4	6.7
		DOP	7.2	1.1	21.3	4.8	24.7	11.2	4.3	0.9	14.4	10.7
		POP	24.8	8.5	42.7	12.9	59.4	11.6	31.3	9.0	39.6	16.9
		F	5.2	1.8	14.3	2.6	19.7	3.5	7.7	2.5	11.7	6.3
		TP	50.3	11.1	72.0	15.6	92.9	21.7	46.4	11.0	65.5	24.3
	II	DIP	6.3	2.5	3.0	1.1	4.5	1.2	3.9	2.1	4.4	2.2
		DOP	7.9	0.7	14.6	2.4	16.4	7.4	2.7	0.6	10.4	6.8
		POP	19.3	6.4	30.4	9.8	46.1	8.7	21.9	6.0	29.4	13.2
		F	3.6	1.0	8.5	2.5	13.7	2.8	4.6	1.4	7.6	4.5
		TP	33.6	6.7	48.0	11.8	67.0	15.3	28.4	6.3	44.3	18.4
	III	DIP	4.4	1.1	2.1	0.8	3.5	1.0	3.5	1.2	3.4	1.3
		DOP	6.0	0.6	10.9	1.7	13.2	5.9	2.4	0.5	8.1	5.3
		POP	16.9	5.4	25.8	8.4	40.3	7.5	20.0	5.1	25.8	11.2
		F	3.0	0.7	6.9	2.2	11.7	2.5	4.6	1.7	6.6	3.8
		TP	27.3	5.6	38.9	9.8	57.1	12.7	25.9	4.9	37.3	15.3
	IV	DIP	2.3	0.4	1.7	0.7	3.4	0.9	1.9	0.7	2.3	1.0
		DOP	4.1	0.2	8.1	2.1	11.8	5.0	17.2	0.5	6.4	4.7
		POP	14.3	4.5	22.2	7.6	37.6	6.5	16.6	4.5	22.7	10.8
		F	2.2	0.3	5.9	2.5	11.4	2.3	3.4	1.3	5.7	4.0
		TP	20.8	4.6	32.0	9.8	52.8	10.8	20.2	4.5	31.5	15.4
1977	I	DIP	19.2	4.9	6.3	1.8	6.3	0.9	13.8	8.0	11.4	7.2
		DOP	7.1	3.0	17.9	3.3	13.3	4.3	4.3	0.4	10.6	6.1
		POP	29.2	5.2	33.4	6.2	40.5	4.4	24.6	5.6	31.9	7.9
		F	7.8	2.7	12.6	3.0	16.5	2.2	8.8	3.0	11.4	4.4
		TP	55.4	6.5	57.6	8.0	60.0	9.1	42.8	5.8	53.9	10.0
	II	DIP	7.3	2.1	2.2	0.6	2.6	0.5	3.6	2.3	3.9	2.6
		DOP	6.1	2.1	11.9	1.4	7.7	2.6	1.9	0.3	6.9	4.0
		POP	17.8	3.5	21.8	5.1	28.2	3.4	15.8	3.7	20.9	6.2
		F	4.7	1.0	7.0	2.5	9.9	1.5	4.4	1.1	6.5	2.8
		TP	31.2	3.4	35.9	5.6	38.5	6.2	21.3	3.9	31.7	8.2
	III	DIP	5.2	1.6	1.6	0.4	1.9	0.3	2.9	1.3	2.9	1.7
		DOP	5.1	1.7	8.9	1.3	6.1	2.0	1.6	0.1	5.4	3.0
		POP	15.1	2.9	18.3	4.1	23.7	2.7	14.3	3.2	17.8	4.9
		F	3.9	0.6	5.6	2.0	8.0	1.3	4.2	1.3	5.4	2.2
		TP	25.3	2.7	28.8	4.3	31.6	4.8	18.8	2.9	26.1	6.1
	IV	DIP	2.8	0.9	1.3	0.4	2.0	0.3	1.4	0.7	1.9	0.9
		DOP	3.6	1.0	6.6	1.1	5.8	1.7	1.1	0.2	4.3	2.4
		POP	12.2	2.4	15.9	3.9	23.2	2.2	11.4	3.0	15.7	5.5
		F	2.8	0.3	5.0	2.2	8.3	1.1	2.8	0.8	4.7	2.6
		TP	18.6	2.3	23.8	4.9	31.0	4.0	13.9	3.1	21.8	7.4

TABLE 8 *Continued.*

Year	Basin	Form of phosphorus	Winter, Jan-Mar		Spring, Apr-Jun		Summer, Jul-Sep		Autumn, Oct-Dec		Annual	
			μ	σ	μ	σ	μ	σ	μ	σ	μ	σ
1978	I	DIP	24.1	4.0	8.0	3.0	6.4	1.4	18.9	8.5	14.3	8.9
		DOP	6.9	2.7	23.0	6.8	11.3	4.2	4.7	0.8	11.4	8.2
		POP	28.8	7.2	42.0	7.6	41.0	5.7	23.5	6.8	33.8	10.5
		F	7.4	2.3	14.3	3.2	15.8	2.3	7.9	2.9	11.4	4.6
		TP	59.7	8.6	73.1	12.2	58.7	10.0	47.1	6.9	59.6	13.3
	II	DIP	7.3	1.2	2.4	0.6	2.2	0.5	4.7	2.5	4.1	2.5
		DOP	4.8	2.0	13.1	2.3	5.6	2.1	1.8	0.4	6.3	4.6
		POP	21.1	5.3	26.2	5.0	26.1	4.0	14.9	3.9	22.1	6.5
		F	4.7	1.1	7.5	2.2	8.5	1.5	4.0	1.0	6.2	2.4
		TP	33.2	6.0	41.7	5.0	33.8	6.1	21.4	4.4	32.5	9.1
	III	DIP	4.7	1.0	1.5	0.4	1.4	0.3	3.8	1.3	2.8	1.7
		DOP	3.4	1.4	8.7	1.6	4.1	1.6	1.6	0.2	4.4	2.9
		POP	18.0	4.3	21.1	3.8	20.9	3.1	13.3	3.2	18.3	4.8
		F	3.7	0.6	5.5	1.5	6.4	1.2	3.8	1.1	4.8	1.6
		TP	26.1	4.6	31.4	3.3	26.4	4.6	18.8	3.1	25.6	6.0
	IV	DIP	2.2	0.5	1.2	0.3	1.6	0.3	1.6	0.7	1.6	0.6
		DOP	2.0	0.8	6.2	1.3	3.9	1.4	0.9	0.3	3.2	2.3
		POP	14.7	3.5	18.0	3.4	20.4	2.6	10.5	2.8	15.9	4.8
		F	2.4	0.3	4.7	1.8	6.8	1.1	2.4	0.7	4.1	2.2
		TP	19.0	3.7	25.4	3.6	25.9	4.1	13.0	2.9	20.8	6.4
1979	I	DIP	37.0	11.8	8.3	3.3	10.9	3.0	19.8	8.3	18.9	13.5
		DOP	8.5	4.1	28.0	7.0	30.1	11.5	6.1	0.5	18.2	13.0
		POP	31.2	10.7	43.9	14.7	64.0	11.9	29.7	8.0	42.2	18.0
		F	8.9	3.7	16.9	5.2	23.2	3.8	9.8	3.1	14.7	7.0
		TP	76.7	13.8	80.2	23.0	104.9	24.8	55.6	8.3	79.4	25.7
	II	DIP	11.7	3.9	3.0	1.3	4.7	1.1	5.0	2.6	6.1	4.1
		DOP	6.7	3.1	16.8	2.2	16.4	6.0	2.5	0.6	10.6	7.2
		POP	20.7	6.2	28.5	9.4	44.4	7.8	17.7	4.6	27.9	12.6
		F	5.9	1.7	9.5	3.7	14.3	2.3	4.9	1.3	8.6	4.4
		TP	39.2	6.1	48.3	12.5	65.5	14.0	25.3	4.9	44.6	17.8
	III	DIP	5.8	1.6	2.0	0.8	3.2	0.7	3.6	1.1	3.6	1.8
		DOP	4.7	2.0	11.6	2.1	12.2	4.3	1.9	0.4	7.6	5.1
		POP	16.6	5.0	23.1	7.4	36.7	6.1	15.5	4.1	23.0	10.3
		F	4.2	0.9	7.3	2.9	11.4	1.8	4.3	1.4	6.9	3.5
		TP	27.1	4.6	36.7	10.0	52.2	10.3	21.0	4.0	34.3	14.2
	IV	DIP	2.5	0.7	1.6	0.9	3.1	0.6	1.6	0.6	2.2	0.9
		DOP	2.8	1.1	8.4	2.8	10.7	3.6	1.2	0.5	5.8	4.5
		POP	13.0	4.1	19.4	6.8	33.9	4.9	12.3	3.9	19.7	10.1
		F	2.6	0.4	6.2	3.1	11.0	1.6	2.9	1.1	5.7	3.8
		TP	18.3	3.9	29.4	10.1	47.7	8.4	15.2	4.2	27.7	14.6

$$\sigma_e^2 = \sum_{t=1}^n (\Delta P - \mu_e)^2 / (n - 1) \quad (13)$$

and

$$\sigma_d^2 = \sum_{t=1}^n (P_{\text{obs}} - \bar{P}_{\text{obs}})^2 / (n - 1) \quad (14)$$

where P_{obs} is the observed phosphorus concentration, ΔP is the difference between observed and simulated phosphorus values, \bar{P}_{obs} is the mean observed phosphorus concentration, given by

$$\bar{P}_{\text{obs}} = \sum_{t=1}^n P_{\text{obs}} / n \quad (15)$$

μ_e is the mean difference between phosphorus concentrations in the observed and simulated time series, given by

$$\mu_e = \sum_{t=1}^n (P_{\text{obs}} - P_{\text{sim}}) / n \quad (16)$$

and P_{sim} is the simulated phosphorus concentration.

The criterion M_e makes it possible to estimate how well the model describes dynamic changes in phosphorus concentration within each of the samples (observed and simulated), and to determine how fluctuations in phosphorus fractions in both samples correspond with one another. According to Beck (1978), reasonable agreement between modeling results and observations may be assumed for cases where the model error M_e , calculated according to eqns. (12)–(16), lies in the range 25–75%. Results of model error calculations for the present model, reported in Table 9, show that the errors in most cases lie within this range. The exceptions are the values 121.8% and 168.1% (Basins III and IV, 1976), 129.4% and 291.0% (Basins III and IV, 1979), and 122.2% (Basin IV, 1976–1979). Table 9 also indicates that a better model description of observed phosphorus concentrations is obtained for 1978 than for other years, and that for the period 1976–1979 the mean error for the whole lake is 51.5%.

In the second test, regression analysis is used to find a quantitative relationship between the concentrations of phosphorus fractions in the observed and simulated time series. The simplest form of the relationship is represented by the simple regression equation

$$P_{\text{sim}} = a + b \cdot P_{\text{obs}} \quad (17)$$

where a and b are regression coefficients, given by the intercept and slope, respectively.

The following principles were employed in performing the regression analysis:

- (i) Each phosphorus observation should have an individual weight in keeping with the characteristics of the raw measurement;
- (ii) The weight of an observation with a large variance should be lower than that of one with a small variance;

TABLE 9 Model errors calculated using eqns. (12)–(16) for observed and simulated total phosphorus data.

Basin	Data sample	1976			1977			1978			1979			1976–1979		
		μ	σ	M_e	μ	σ	M_e	μ	σ	M_e	μ	σ	M_e	μ	σ	M_e
I	Observed	35.3	26.8	62.1	35.4	27.6	25.8	34.7	28.5	21.3	37.8	40.4	58.8	35.9	31.6	48.5
	Simulated	29.2	21.1		25.7	14.0		26.6	13.2		40.5	31.0		30.9	22.0	
II	Observed	21.9	16.2	74.3	27.6	21.8	36.3	20.7	16.8	30.3	20.7	18.1	66.0	22.9	18.5	78.5
	Simulated	20.4	13.9		15.2	13.1		14.5	9.2		14.5	14.7		18.3	16.4	
III	Observed	16.1	11.6	121.8	17.6	14.2	34.5	14.4	10.8	45.4	16.0	16.2	129.4	16.1	13.5	90.4
	Simulated	17.3	12.8		12.3	8.3		11.7	7.3		16.9	18.4		14.5	12.9	
IV	Observed	13.9	10.0	168.1	15.4	14.7	73.2	11.4	9.6	69.6	10.0	7.2	291.0	12.7	10.9	122.2
	Simulated	15.0	12.9		10.9	12.6		6.8	8.0		14.4	12.2		12.5	12.0	
Whole lake	Observed	21.8	19.2	67.2	23.7	21.5	33.3	20.3	20.0	24.7	21.5	26.1	51.6	21.9	22.1	51.5
	Simulated	20.5	15.7		15.8	12.4		15.6	9.9		23.7	20.4		19.0	15.8	

TABLE 10 Regression analysis statistics^a calculated using eqn. (17) with the total phosphorus data sets.

Year	Basin	Number of data	Data sample	μ (mg P l ⁻¹)	σ (mg P l ⁻¹)	Regression coefficients					
						Simple regression			Weighted regression		
						a	b	R^2	a	b	R^2
1976	I	40	Observed	0.0358	0.0269	0.0088	0.578	0.425	0.0084	0.586	0.429
			Simulated	0.0296	0.0239		(5.2)			(5.2)	
	II	40	Observed	0.0222	0.0162	0.0039	0.762	0.454	0.0037	0.804	0.543
			Simulated	0.0208	0.0183		(5.5)			(6.5)	
	III	40	Observed	0.0163	0.0116	0.0047	0.791	0.345	0.0013	0.945	0.527
			Simulated	0.0176	0.0157		(4.3)			(6.3)	
	IV	40	Observed	0.0141	0.0100	0.0052	0.717	0.241	-0.0025	1.182	0.454
			Simulated	0.0153	0.0146		(3.4)			(5.5)	
	Whole lake	160	Observed	0.0218	0.0192	0.0062	0.656	0.437	0.0053	0.668	0.480
			Simulated	0.0205	0.0191		(16.0)			(12.0)	
1977	I	45	Observed	0.0362	0.0274	0.0044	0.593	0.810	0.0044	0.594	0.797
			Simulated	0.0259	0.0181		(13.2)			(12.7)	
	II	45	Observed	0.0281	0.0217	0.0022	0.472	0.722	0.0032	0.467	0.700
			Simulated	0.0154	0.0121		(10.3)			(9.8)	
	III	53	Observed	0.0179	0.0141	0.0024	0.557	0.670	0.0037	0.523	0.735
			Simulated	0.0124	0.0096		(10.0)			(11.6)	
	IV	45	Observed	0.0156	0.0148	0.0058	0.321	0.297	0.0023	0.522	0.368
			Simulated	0.0108	0.0087		(4.2)			(4.9)	
	Whole lake	188	Observed	0.0238	0.0215	0.0030	0.538	0.715	0.0029	0.556	0.741
			Simulated	0.0158	0.0137		(21.5)			(22.9)	
1978	I	40	Observed	0.0353	0.0287	0.0051	0.617	0.854	0.0046	0.624	0.859
			Simulated	0.0269	0.0192		(14.5)			(14.8)	
	II	40	Observed	0.0210	0.0169	0.0017	0.626	0.702	0.0021	0.567	0.628
			Simulated	0.0148	0.0126		(9.2)			(7.8)	
	III	40	Observed	0.0146	0.0109	0.0020	0.683	0.565	-0.0014	0.872	0.703
			Simulated	0.0119	0.0099		(6.8)			(9.2)	
	IV	40	Observed	0.0116	0.0097	0.0029	0.583	0.400	0.0023	0.629	0.632
			Simulated	0.0096	0.0089		(4.9)			(7.9)	
	Whole lake	160	Observed	0.0203	0.0200	0.0026	0.643	0.777	0.0023	0.646	0.800
			Simulated	0.0156	0.0147		(23.3)			(24.9)	

1979	I	50	Observed	0.0382	0.0408	0.0022	0.484	0.420	0.0022	0.497	0.437
			Simulated	0.0408	0.0305		(5.7)			(6.0)	
	II	50	Observed	0.0210	0.0183	0.0063	0.766	0.493	0.0001	0.858	0.500
			Simulated	0.0224	0.0199		(6.7)			(6.8)	
	III	50	Observed	0.0162	0.0163	0.0120	0.320	0.109	0.0131	0.304	0.133
			Simulated	0.0172	0.0159		(2.4)			(2.6)	
	IV	45	Observed	0.0101	0.0072	0.0031	1.147	0.314	0.0031	0.980	0.326
			Simulated	0.0147	0.0148		(4.3)			(4.5)	
	Whole lake	195	Observed	0.0214	0.0262	0.0109	0.594	0.439	0.0099	0.596	0.462
			Simulated	0.0237	0.0235		(12.2)			(12.8)	
1976– 1979	I	175	Observed	0.0360	0.0317	0.0112	0.549	0.515	0.0113	0.551	0.514
			Simulated	0.0310	0.0242		(13.5)			(13.4)	
	II	175	Observed	0.0228	0.0185	0.0044	0.606	0.468	0.0032	0.588	0.503
			Simulated	0.0183	0.0164		(12.2)			(13.1)	
	III	183	Observed	0.0162	0.0136	0.0061	0.520	0.286	0.0061	0.513	0.345
			Simulated	0.0146	0.0132		(8.5)			(9.7)	
	IV	170	Observed	0.0127	0.0109	0.0061	0.512	0.210	0.0033	0.660	0.396
			Simulated	0.0126	0.0122		(6.6)			(10.4)	
	Whole lake	703	Observed	0.0219	0.0221	0.0060	0.595	0.503	0.0058	0.596	0.531
			Simulated	0.0190	0.0185		(26.6)			(28.2)	

^at-Statistics are given in parentheses.

- (iii) The weight of an observation recorded in a basin where there are more sampling stations per unit area (i.e., where the "density coefficient of observation" is higher) should be higher than that for one in a basin with a lower density of observations;
- (iv) The weight of an observation with a high mean value should be higher than that for one with a low mean value.

The application of weights is generally accepted in regression analysis when the observations are known to include some measurement errors or when state variables do not quite correspond to those specified in the model (Allard 1977). According to the principles formulated above, the weight, WG , of individual phosphorus observations may be computed as

$$WG = (N/S) \cdot \frac{P_m^t}{P_{\max}^t - P_{\min}^t} \quad (18)$$

where N is the number of sampling stations in the basin considered, S is the surface area of the basin considered, and P_{\max}^t , P_{\min}^t , and P_m^t are, respectively, maximum, minimum, and mean phosphorus concentrations at time t in a raw measurement set.

Uncertainties in the observations (or measurement errors in the original data set) will increase the dispersion of the P_{obs} measurements around their expected value for each value of P_{sim} in the regression relationship. The standard linear regression statistics, both with and without correction for the weight of individual observations, were computed using eqn. (17). Model adequacy may be estimated from the regression analysis on the basis of statistical values of the mean (μ) and standard deviation (σ), as well as the values of R^2 , a , b , and the t-statistic (Allard 1977).

The results of the analysis for combined time series for all phosphorus compartments are summarized in Table 10; t-statistics are shown in parentheses. On the basis of the data presented in Table 10, the following conclusions may be drawn:

- (i) The model describes reasonably well the observed fluctuations in all the phosphorus fractions;
- (ii) The weighting procedure increases the mean values of all the phosphorus fractions and slightly changes the values of the standard deviations in the time series of phosphorus compartment observations;
- (iii) Satisfactory correlation between phosphorus concentrations in observed and simulated time series is found, with a tendency for regression coefficient a to be close to or slightly larger than zero,* and the relationship between the phosphorus fractions in the two series is considered to be quite adequate;
- (iv) The R^2 values show that the model description of the trends in temporary changes in concentration of the phosphorus fractions in individual basins over the period 1976-1979 is acceptable.

* The order of magnitude of a is comparable with that of the standard error of regression.

TABLE 11 Theil's inequality coefficient for individual phosphorus compartments and for combined phosphorus data.

Year	Basin	TP	POP	TDP	DIP	DOP	Combined P-data
1976	I	0.211	0.251	0.374	0.116	0.468	0.267
	II	0.182	0.359	0.289	0.407	0.396	0.255
	III	0.200	0.503	0.325	0.371	0.331	0.296
	IV	0.225	0.596	0.410	0.476	0.387	0.338
	Whole lake	0.205	0.361	0.353	0.299	0.429	0.276
1977	I	0.214	0.222	0.223	0.395	0.314	0.223
	II	0.336	0.295	0.347	0.318	0.400	0.330
	III	0.252	0.225	0.326	0.367	0.344	0.259
	IV	0.373	0.375	0.385	0.500	0.407	0.377
	Whole lake	0.271	0.262	0.288	0.402	0.350	0.277
1978	I	0.189	0.198	0.161	0.296	0.327	0.198
	II	0.205	0.252	0.347	0.394	0.326	0.241
	III	0.151	0.323	0.367	0.394	0.300	0.232
	IV	0.164	0.441	0.468	0.467	0.411	0.291
	Whole lake	0.187	0.244	0.272	0.349	0.332	0.219
1979	I	0.284	0.305	0.285	0.414	0.376	0.292
	II	0.240	0.262	0.263	0.306	0.434	0.256
	III	0.389	0.494	0.227	0.361	0.335	0.400
	IV	0.334	0.545	0.340	0.350	0.497	0.360
	Whole lake	0.294	0.336	0.276	0.384	0.394	0.307
1976- 1979	I	0.242	0.262	0.279	0.352	0.382	0.259
	II	0.251	0.288	0.304	0.355	0.391	0.273
	III	0.289	0.408	0.307	0.375	0.329	0.319
	IV	0.293	0.474	0.396	0.446	0.415	0.351
	Whole lake	0.255	0.309	0.299	0.362	0.381	0.279

In the third statistical test of model adequacy, Theil's inequality coefficient (Theil 1971) is computed using the formula

$$\rho = \frac{\left[1/n \sum_{i=1}^n (P_{\text{obs}} - P_{\text{sim}})^2 \right]^{1/2}}{\left[1/n \sum_{i=1}^n (P_{\text{obs}})^2 \right]^{1/2} + \left[1/n \sum_{i=1}^n (P_{\text{sim}})^2 \right]^{1/2}} \quad (19)$$

This coefficient measures the degree to which a simulation model describes the observations; it varies between 0 and 1, with a value of zero implying that the model description is perfect. The values of the coefficient calculated for individual phosphorus fractions, for each basin and for each year studied, as well as for combined phosphorus data and the entire study period, 1976-1979, are shown in Table 11. Summarizing the results in the table we see that:

- (i) The ranges of errors in the simulation of phosphorus dynamics are 0.205-0.294 (mean 0.255) for total phosphorus, 0.244-0.361 (mean 0.309) for particulate organic-P, 0.272-0.353 (mean 0.299) for total dissolved-P, 0.299-0.402 (mean 0.362) for DIP, and 0.332-0.429 (mean 0.381) for DOP;

TABLE 12 Monthly and annual phosphorus inputs (in mg P l⁻¹ and expressed as percentages of total phosphorus load) to Keszthely Bay from the Zala river.

Year	Month	PD		DIP		F		B		Total phosphorus	
		mg P l ^{-1a}	%	mg P l ^{-1a}	%	mg P l ^{-1a}	%	mg P l ^{-1a}	%	mg P l ^{-1a}	%
1976	Jan	0.0258	52.1	0.0224	45.3	0.0012	2.4	0.00008	0.2	0.04948	7.4
	Feb	0.0019	4.3	0.0402	91.2	0.0019	4.3	0.00009	0.2	0.04409	6.6
	Mar	0.0030	8.4	0.0296	82.9	0.0030	8.4	0.00011	0.3	0.03571	5.3
	Apr	0.0497	54.5	0.0387	42.4	0.0027	3.0	0.00009	0.1	0.09119	13.7
	May	0.0527	62.7	0.0292	34.8	0.0020	2.4	0.00010	0.1	0.08400	12.6
	Jun	0.0326	63.8	0.0172	33.7	0.0012	2.4	0.00007	0.1	0.05107	7.7
	Jul	0.0156	58.1	0.0104	38.8	0.0008	3.0	0.00003	0.1	0.02683	4.0
	Aug	0.0069	28.5	0.0168	69.3	0.0005	2.1	0.00003	0.1	0.02423	3.6
	Sep	0.0143	41.5	0.0190	55.2	0.0011	3.2	0.00004	0.1	0.03444	5.2
	Oct	0.0074	26.6	0.0196	70.4	0.0008	2.9	0.00005	0.1	0.02785	4.2
	Nov	0.0192	43.9	0.0234	53.5	0.0011	2.4	0.00007	0.2	0.04377	6.6
	Dec	0.1238	80.2	0.0278	18.0	0.0027	1.7	0.00017	0.1	0.15447	23.1
Annual		0.3529	52.9	0.2943	44.1	0.0190	2.9	0.00093	0.1	0.66713	100.0
1977	Jan	0.1362	79.6	0.0313	18.3	0.0035	2.0	0.00019	0.1	0.17119	18.0
	Feb	0.1265	71.6	0.0415	23.6	0.0084	4.7	0.00026	0.1	0.17666	18.6
	Mar	0.0477	54.2	0.0333	37.9	0.0068	7.7	0.00015	0.2	0.08795	9.2
	Apr	0.1063	73.7	0.0333	23.1	0.0045	3.1	0.00016	0.1	0.14426	15.1
	May	0.0268	41.3	0.0308	47.5	0.0072	11.1	0.00007	0.1	0.06487	6.8
	Jun	0.0197	44.5	0.0238	53.8	0.0007	1.6	0.00004	0.1	0.04424	4.6
	Jul	0.0043	11.1	0.0330	85.0	0.0015	3.8	0.00003	0.1	0.03883	4.1
	Aug	0.0077	21.8	0.0253	71.6	0.0023	6.5	0.00003	0.1	0.03533	3.7
	Sep	0.0049	15.7	0.0247	79.1	0.0016	5.1	0.00002	0.1	0.03122	3.3
	Oct	0.0102	19.7	0.0401	77.3	0.0015	2.9	0.00005	0.1	0.05185	5.4
	Nov	0.0224	41.6	0.0306	56.8	0.0008	1.5	0.00005	0.1	0.05385	5.6
	Dec	0.0174	32.3	0.0357	66.3	0.0007	1.3	0.00008	0.1	0.05388	5.6
Annual		0.5301	55.6	0.3834	40.2	0.0395	4.1	0.00113	0.1	0.95413	100.0

1978	Jan	0.0196	45.4	0.0230	53.3	0.0005	1.2	0.00006	0.1	0.04316	4.4
	Feb	0.0360	45.3	0.0428	53.9	0.0006	0.7	0.00008	0.1	0.07948	8.1
	Mar	0.0161	28.1	0.0405	70.8	0.0006	1.0	0.00010	0.1	0.05730	5.8
	Apr	0.0579	55.0	0.0447	42.5	0.0025	2.4	0.00013	0.1	0.10523	10.7
	May	0.1043	66.4	0.0488	31.0	0.0040	2.5	0.00012	0.1	0.15722	16.0
	Jun	0.1153	70.2	0.0453	27.6	0.0034	2.1	0.00011	0.1	0.16411	16.8
	Jul	0.0469	48.9	0.0472	49.2	0.0017	1.8	0.00008	0.1	0.09568	9.8
	Aug	0.0184	41.8	0.0238	54.0	0.0018	4.1	0.00004	0.1	0.04404	4.5
	Sep	0.0240	39.7	0.0342	56.6	0.0022	3.6	0.00004	0.1	0.06044	6.2
	Oct	0.0288	40.1	0.0407	56.7	0.0022	3.1	0.00006	0.1	0.07176	7.3
	Nov	0.0136	27.7	0.0344	70.2	0.0010	2.0	0.00005	0.1	0.04905	5.0
	Dec	0.0195	37.1	0.0319	60.7	0.0011	2.1	0.00007	0.1	0.05257	5.4
Annual		0.5004	51.0	0.4573	46.7	0.0216	2.2	0.00094	0.1	0.98024	100.0
1979	Jan	0.0675	60.6	0.0429	38.5	0.0009	0.8	0.00010	0.1	0.11140	8.1
	Feb	0.1538	66.6	0.0751	32.6	0.0017	0.7	0.00027	0.1	0.23087	16.6
	Mar	0.0331	37.7	0.0537	61.2	0.0009	1.0	0.00015	0.1	0.08785	6.4
	Apr	0.0678	62.5	0.0381	35.1	0.0025	2.3	0.00012	0.1	0.10852	7.8
	May	0.0663	57.7	0.0452	39.4	0.0032	2.8	0.00010	0.1	0.11480	8.3
	Jun	0.0899	63.6	0.0493	34.8	0.0021	1.5	0.00009	0.1	0.14139	10.2
	Jul	0.0649	50.5	0.0617	47.9	0.0019	1.5	0.00010	0.1	0.12860	9.3
	Aug	0.0528	58.2	0.0346	38.2	0.0032	3.5	0.00007	0.1	0.09067	6.6
	Sep	0.0179	33.4	0.0331	61.8	0.0025	4.7	0.00005	0.1	0.05355	3.9
	Oct	0.0280	33.4	0.0534	63.8	0.0023	2.7	0.00006	0.1	0.08376	6.1
	Nov	0.1121	71.1	0.0428	27.2	0.0025	1.6	0.00013	0.1	0.15753	11.4
	Dec	0.0293	40.0	0.0412	56.3	0.0026	3.5	0.00017	0.2	0.07327	5.3
Annual		0.7834	56.7	0.5711	41.3	0.0263	1.9	0.00141	0.1	1.38221	100.0

^aPer month or per year, as appropriate.

- (ii) The range of errors in the simulation of combined phosphorus dynamics for Basin I is 0.198–0.292 (mean 0.259), while for Basins II–IV it is 0.241–0.330 (mean 0.273), 0.232–0.400 (mean 0.319), and 0.291–0.377 (mean 0.351), respectively;
- (iii) The error in the simulation of phosphorus fractions is estimated as 0.276 for 1976, 0.277 for 1977, 0.219 for 1978, and 0.307 for 1979, and 0.279 for the overall four-year study period.

Thus the results of the different statistical tests applied allow us to conclude that, on the whole, the simulation results represent reasonably well the phosphorus transformation phenomena at work in Lake Balaton, so far as we can tell from the relatively sparse phosphorus measurements available for each individual year within the period studied.

6. ANALYSIS OF PHOSPHORUS TRANSFORMATION PATHWAYS IN THE LAKE BALATON ECOSYSTEM

During the analysis of the simulation results obtained for 1976–1979, it also appeared worthwhile to try to derive additional information that might increase our understanding of the role of external sources in phosphorus loading as well as the significance of individual processes in the internal phosphorus cycling and other mechanisms within the Lake Balaton ecosystem. Quantitative assessments of the phosphorus loading from identified sources, phosphorus exchange in the sediment–water layer, and phosphorus turnover in the different areas of the lake are prerequisites for the scientific understanding and explanation of the internal phosphorus cycling in the lake and the eutrophication of the water body.

This section of the report analyzes the main phosphorus transformation pathways in the Lake Balaton ecosystem that are evaluated by the model.

6.1. Phosphorus Loading

6.1.1. Inputs from the Zala River

Among the different sources of phosphorus load, the BALSECT model explicitly considers the phosphorus inputs from the Zala river and other tributaries, from rainfall, and from external nonpoint sources (watershed P-load). From the input data used in the simulation runs, the model calculates the quantities of the different forms of phosphorus entering the lake from these sources. Table 12 presents the monthly and annual average inputs of each type of phosphorus arriving in Keszthely Bay from the Zala river, as evaluated by the model. These inputs are expressed in units of $\text{mg P l}^{-1} \text{ month}^{-1}$ or $\text{mg P l}^{-1} \text{ year}^{-1}$, as appropriate. The table also reports each of these data in the form of a percentage of the total amount of phosphorus that the river carries into Keszthely Bay in each month or each year, respectively; in the discussion below, these percentages are given in brackets [·] after the corresponding input amounts.

It is immediately evident that the total average phosphorus input from water discharged by the Zala river significantly increases from 0.667 in 1976 to 0.954 $\text{mg P l}^{-1} \text{ year}^{-1}$ in 1977, primarily as a result of an increase in the amount of inanimate particulate organic-P. The inputs of inanimate particulate organic-P and DIP

in the river's phosphorus load for 1976 were estimated as 0.353 [corresponding to 52.9% of the total annual load] and 0.294 mg P l⁻¹ year⁻¹ [44.1%], respectively. For 1977 these values were 0.530 [55.6%] and 0.383 mg P l⁻¹ year⁻¹ [40.2%], respectively.

Between 1977 and 1978 the average total input of phosphorus from the water discharged to the lake by the Zala river increased slightly to 0.980 mg P l⁻¹ year⁻¹. However, in contrast to 1977, the proportions of inanimate particulate organic-P and DIP in the total phosphorus load changed, so that in 1978 the annual inputs were 0.500 [51%] for inanimate particulate organic-P and 0.457 mg P l⁻¹ year⁻¹ [46.7%] for DIP.

In 1979 the proportions of inanimate particulate organic-P and DIP in the total load from the Zala river were close to the 1977 values. However, the absolute inputs of phosphorus from the water discharged by the river were significantly higher in 1979: the total input from all sources was 1.382 mg P l⁻¹ year⁻¹, of which 0.783 [56.7%] was in the form of inanimate particulate organic-P and 0.571 [41.3%] was contributed by DIP.

The data in Table 12 also show that the time distribution within the year of total phosphorus load from the Zala river varied from 1976 to 1979. In 1976 the highest phosphorus loading occurred in April, May, and December, whereas 1977 saw the highest loadings taking place in the period January–April. In 1978 the highest loading from the Zala river occurred in April–July, while in 1979 the phosphorus input from the river was highest in February, May–July, and November.

In addition, the data in Table 12 make it possible to estimate quantitatively the roles of inanimate particulate organic-P and DIP as major components of the Zala river's phosphorus load for individual months during the period studied. In 1976 inanimate particulate organic-P was markedly predominant over DIP in May, June, and December, whereas DIP was predominant in February, March, August, and October. For the remaining months of 1976, the contributions of these two components to the total Zala river phosphorus load were more evenly balanced.

In 1977 inanimate particulate organic-P predominated over DIP during the period January–April. In May 1977 the inputs of particulate-P and DIP from the Zala river discharge water were almost equivalent. Over the period June–December 1977, the concentration of DIP was considerably higher than that of particulate-P. In 1978 particulate-P was only markedly predominant in May and June; in turn, DIP was the major contributor in March, November, and December. In the other months of the year, the inputs of each of these two phosphorus fractions from the Zala river to the lake showed less marked differences.

In 1979 the inanimate particulate organic-P input was higher than the DIP input in January, February, April–June, August, and November. DIP contributed significantly more than particulate-P to the total phosphorus load in the months of March, September, and October.

6.1.2. *Inputs from External Sources*

Model assessments of the annual phosphorus inputs to each of the four basins of Lake Balaton over the period 1976–1979 from external sources are shown in Table 13. For DIP the model considers five groups of sources: rivers and streams, urban runoff, sewage, atmospheric pollution, and sediments. For particulate-P the model calculates the contributions from rivers and streams, urban runoff, atmospheric pollution, and sediments.

TABLE 13 Annual phosphorus inputs (in mg P l⁻¹ year⁻¹) to the four basins of Lake

Source	1976				1977			
	I	II	III	IV	I	II	III	IV
<i>I. DIP from:</i>								
Tributaries	0.2943	0.0464	0.0068	0.0009	0.3834	0.0606	0.0088	0.0011
Urban runoff	0.0123	0.0059	0.0051	0.0045	0.0129	0.0061	0.0053	0.0047
Sewage (direct plus mixed)	0.0114	0.0055	0.0396	0.0395	0.0114	0.0055	0.0396	0.0395
Atmospheric pollution	0.0111	0.0083	0.0074	0.0068	0.0110	0.0082	0.0073	0.0067
Sediments	0.2278	0.0649	0.0467	0.0321	0.1227	0.0349	0.0252	0.0173
Total DIP load	0.5569	0.1310	0.1056	0.0838	0.5413	0.1154	0.0862	0.0695
<i>II. DOP from:</i>								
Atmospheric pollution	0.0166	0.0125	0.0111	0.0102	0.0164	0.0124	0.0110	0.0101
<i>III. PD from:</i>								
Tributaries	0.3529	0.0497	0.0201	0.0021	0.5301	0.0748	0.0302	0.0032
Urban runoff	0.0915	0.0435	0.0376	0.0336	0.0863	0.0395	0.0355	0.0317
Atmospheric pollution	0.0222	0.0167	0.0148	0.0136	0.0219	0.0165	0.0147	0.0134
Sediments	3.1109	1.9728	1.5555	1.1983	1.7942	1.1378	0.8971	0.6911
Total PD load	3.5775	2.0827	1.6280	1.2476	2.4325	1.2686	0.9775	0.7394
Total phosphorus load	4.1510	2.2262	1.7447	1.3416	2.9902	1.3964	1.0747	0.8190

6.2. Phosphorus Exchange in the Sediment–Water Layer

It is well known that sediments play a significant role in the various nutrient cycles and their importance as a potential source of nutrients in the development of water-body eutrophication has been recognized (Leonov 1981b). However, according to many researchers, phosphorus exchange through the sediment–water interface has not been directly demonstrated because phosphorus sedimentation and resuspension are difficult to measure. In the present study, a quantitative assessment of the influence of sediments on phosphorus dynamics in the various basins of Lake Balaton was made, on the basis of the model and a number of theoretical assumptions. Table 13 shows the annual phosphorus inputs, both DIP and inanimate particulate organic-P, from the sediments. These sediment contributions are then compared with total external phosphorus load in Table 14.

On the basis of the simulation results it seems reasonable to assume that, in Lake Balaton, the sediments play a dominant role in both the phosphorus cycle and in water-body eutrophication as a whole. Table 15 summarizes the modeling results for phosphorus exchange in the sediment–water layer for each basin studied and for individual seasons within the period 1976–1979. The table includes the rates of PD resuspension and sedimentation, DIP release from sediments, and

Balaton from external sources, as evaluated by the model.

1978				1979			
I	II	III	IV	I	II	III	IV
0.4573	0.0723	0.0105	0.0014	0.5710	0.0903	0.0131	0.0017
0.0126	0.0060	0.0052	0.0046	0.0129	0.0061	0.0053	0.0047
0.0114	0.0055	0.0396	0.0395	0.0114	0.0055	0.0396	0.0395
0.0096	0.0072	0.0064	0.0059	0.0106	0.0080	0.0071	0.0065
0.1112	0.0317	0.0228	0.0157	0.1901	0.0541	0.0390	0.0268
0.6021	0.1227	0.0846	0.0671	0.7960	0.1640	0.1041	0.0793
0.0144	0.0108	0.0096	0.0088	0.0159	0.0119	0.0106	0.0098
0.5004	0.0706	0.0285	0.0030	0.7834	0.1105	0.0447	0.0048
0.0914	0.0434	0.0375	0.0336	0.0932	0.0443	0.0383	0.0342
0.0192	0.0145	0.0129	0.0118	0.0211	0.0159	0.0141	0.0130
2.2826	1.4475	1.1413	0.8792	2.2548	1.4299	1.1274	0.8685
2.8936	1.5760	1.2202	0.9276	3.1525	1.6006	1.2245	0.9205
3.5101	1.7095	1.3144	1.0035	3.9644	1.7765	1.3392	1.0096

TABLE 14 Estimated contribution of sediments to phosphorus loading in each basin of Lake Balaton, 1976–1979.

Year	Sediment contribution (%) in each basin			
	I	II	III	IV
<i>Percentage of total DIP loading</i>				
1976	40.9	49.5	44.2	38.3
1977	22.6	30.2	29.2	24.9
1978	18.5	25.8	26.9	23.4
1979	23.9	33.0	37.5	33.8
<i>Percentage of total PD loading</i>				
1976	87.0	94.7	95.5	96.0
1977	73.7	89.7	91.8	93.5
1978	78.9	91.8	93.5	94.8
1979	71.5	89.3	92.1	94.3

TABLE 15 Seasonal phosphorus exchanges^a through the sediment-water interface, as evaluated by the model.

Basin	Season	Year	PD			DIP release from sediment	Net phosphorus losses to sediment		
			Resus- pension	Sedimen- tation	Net loss to sediment		(kg P day ⁻¹)		
I	Winter (Jan-Mar)	1976	0.77189	0.80821	0.03632	0.00913	0.02719	24.7	
		1977	0.51694	0.88846	0.37152	0.01033	0.36119	329.1	
		1978	0.78269	0.88366	0.10097	0.01383	0.08714	79.4	
		1979	0.62359	0.92530	0.30171	0.01214	0.28957	263.8	
	Spring (Apr-Jun)	1976	0.84344	1.03969	0.19625	0.07556	0.12069	110.0	
		1977	0.48396	0.71738	0.23342	0.04505	0.18837	171.6	
		1978	0.64713	1.02994	0.38281	0.04021	0.34260	312.1	
		1979	0.57123	0.87431	0.30308	0.06659	0.23649	215.5	
	Summer (Jul-Sep)	1976	0.85169	1.02297	0.17128	0.12009	0.05119	46.6	
		1977	0.36543	0.52457	0.15914	0.05284	0.10630	96.8	
		1978	0.41672	0.67223	0.25551	0.04599	0.20952	190.9	
		1979	0.63297	0.96651	0.33354	0.09809	0.23545	214.5	
	Autumn (Oct-Dec)	1976	0.64389	0.87365	0.22976	0.02305	0.20671	188.3	
		1977	0.42786	0.56561	0.13775	0.01444	0.12331	112.3	
		1978	0.43610	0.58150	0.14540	0.01121	0.13419	122.3	
		1979	0.42701	0.71898	0.29197	0.01326	0.27871	253.9	
	II	Winter (Jan-Mar)	1976	0.48949	0.51182	0.02233	0.00260	0.01973	90.5
			1977	0.32782	0.42579	0.09797	0.00294	0.09503	436.1
			1978	0.49634	0.53612	0.03978	0.00394	0.03584	164.5
			1979	0.39545	0.48412	0.08867	0.00346	0.08521	391.0
Spring (Apr-Jun)		1976	0.53487	0.59710	0.06223	0.02152	0.04071	186.8	
		1977	0.30690	0.37562	0.06872	0.01310	0.05562	255.2	
		1978	0.41038	0.51741	0.10703	0.01145	0.09558	438.6	
		1979	0.36224	0.44140	0.07916	0.01897	0.06019	276.2	
Summer (Jul-Sep)		1976	0.54009	0.63504	0.09495	0.03422	0.06073	278.9	
		1977	0.23173	0.30466	0.07293	0.01506	0.05787	265.6	
		1978	0.26426	0.36024	0.09598	0.01311	0.08287	380.3	
		1979	0.40139	0.52883	0.12744	0.02794	0.09950	456.6	
Autumn (Oct-Dec)		1976	0.40832	0.49509	0.08677	0.00657	0.08020	368.0	
		1977	0.27132	0.32497	0.05365	0.00411	0.04954	227.3	
		1978	0.27655	0.32430	0.04775	0.00319	0.04456	204.5	
		1979	0.27079	0.36157	0.09078	0.00379	0.08699	399.2	

^aIn mg P l⁻¹ per quarter (i.e. 3 months), unless otherwise specified.

TABLE 15 *Continued.*

Basin	Season	Year	PD			DIP release from sediment	Net phosphorus losses to sediment		
			Resus- pension	Sedimen- tation	Net loss to sediment		(kg P day ⁻¹)		
III	Winter (Jan-Mar)	1976	0.38594	0.40174	0.01580	0.00187	0.01393	92.9	
		1977	0.25847	0.32011	0.06164	0.00212	0.05952	396.8	
		1978	0.39135	0.41655	0.02520	0.00284	0.02236	149.1	
		1979	0.31180	0.36206	0.05026	0.00249	0.04777	318.5	
	Spring (Apr-Jun)	1976	0.42172	0.45750	0.03578	0.01550	0.02028	135.2	
		1977	0.24198	0.28428	0.04230	0.00923	0.03307	220.5	
		1978	0.32355	0.38073	0.05718	0.00831	0.04887	325.8	
		1979	0.28560	0.32530	0.03970	0.01365	0.02605	173.7	
	Summer (Jul-Sep)	1976	0.42585	0.49464	0.06879	0.02463	0.04416	294.4	
		1977	0.18272	0.23145	0.04873	0.01084	0.03789	252.6	
		1978	0.20836	0.26341	0.05505	0.00943	0.04562	304.1	
		1979	0.31648	0.39278	0.07630	0.02012	0.05618	374.5	
	Autumn (Oct-Dec)	1976	0.32194	0.39105	0.06911	0.00472	0.06439	429.3	
		1977	0.21393	0.25810	0.04417	0.00292	0.04120	274.7	
		1978	0.21805	0.25008	0.03203	0.00230	0.02973	198.2	
		1979	0.21351	0.27890	0.06539	0.00272	0.06267	417.8	
	IV	Winter (Jan-Mar)	1976	0.29732	0.30623	0.00891	0.00129	0.00762	67.9
			1977	0.19912	0.23544	0.03632	0.00146	0.03486	310.6
			1978	0.30148	0.31431	0.01283	0.00195	0.01088	96.9
			1979	0.24020	0.26514	0.02494	0.00171	0.02323	207.0
Spring (Apr-Jun)		1976	0.32488	0.34561	0.02073	0.01064	0.01009	89.9	
		1977	0.18641	0.21434	0.02793	0.00635	0.02158	192.3	
		1978	0.24926	0.28800	0.03874	0.00567	0.03307	294.7	
		1979	0.22002	0.23944	0.01942	0.00939	0.01003	89.4	
Summer (Jul-Sep)		1976	0.32806	0.39245	0.06439	0.01693	0.04746	422.9	
		1977	0.14076	0.19130	0.05054	0.00745	0.04309	384.0	
		1978	0.16051	0.21690	0.05639	0.00648	0.04991	444.7	
		1979	0.24381	0.30795	0.06414	0.01420	0.04994	445.0	
Autumn (Oct-Dec)		1976	0.24801	0.29771	0.04970	0.00323	0.04647	414.1	
		1977	0.16480	0.19500	0.03020	0.00204	0.02816	250.9	
		1978	0.16797	0.19140	0.02343	0.00158	0.02185	194.7	
		1979	0.16447	0.20814	0.04367	0.00186	0.04181	372.6	

net phosphorus losses to sediments, making it possible to analyze seasonal variations in the movement of phosphorus between water and sediment in the different parts of the lake. The following conclusions may be drawn:

- (i) In 1976 the amount of phosphorus resuspended was markedly higher than in 1977–1979; this may be explained by the influence of wind, because wind speeds were much higher in 1976 than in the later years.
- (ii) Resuspension of inanimate particulate organic-P was higher in the winter and spring months than in summer and autumn.
- (iii) Phosphorus sedimentation was higher in the spring and summer months than in autumn and winter.
- (iv) Net inanimate particulate organic-P losses to sediment through the continued effects of resuspension and sedimentation were higher in the spring and summer months (as with sedimentation), when the rates of ecological phosphorus transformation processes were high and the amount of particulate-P formed by biochemical processes significant; strong winds, such as those recorded in 1976, may have decreased overall particulate-P losses by increasing the intensity of sediment resuspension.
- (v) The amount of DIP released from the sediments was highest during the spring and summer months as a result of conditions favorable to phosphorus conversion in the sediments, primarily the higher temperature; during the autumn and winter months the sediment DIP release was 5–10 times smaller than in the spring and summer.
- (vi) The amount of DIP released by the sediment was not sufficient to compensate the phosphorus losses due to the sedimentation of inanimate particulate organic-P, and the contribution of sediment DIP release to the total phosphorus budget was only of any real, quantitative significance during the spring and summer months.
- (vii) There is a general tendency toward phosphorus accumulation in the sediments throughout all seasons of the year, although this may be perturbed during periods with strong winds, such as the winter and spring of 1976, when the fluxes of inanimate particulate organic-P due to resuspension and to sedimentation were almost in balance.

6.3. Phosphorus Cycling in Lake Balaton

The principal goal of our study was to understand how the conversion of phosphorus between compartments develops in the water body, in order to obtain quantitative information on phosphorus cycling as a whole. This is necessary to assess the relative importance of the natural phosphorus cycle in aquatic ecosystem behavior and in water body eutrophication, and particularly the influence of additional phosphorus entering the water body from the watershed area.

In this study, the model used recognizes five phosphorus compartments (DIP, DOP, PD, F, and B) and makes it possible to evaluate the quantities of phosphorus in the individual phosphorus fractions (or phosphorus pools) and also the phosphorus flows from one compartment to another. The model also estimates the various fluxes of the phosphorus cycle during each year studied, on the basis of the

empirical data supplied. The following phosphorus fluxes were considered of particular interest in the case of Lake Balaton:

- (i) *External input-output phosphorus fluxes* ($EF_i - OF_i$), which take into account the total transport of phosphorus through the basins of the lake;
- (ii) *System phosphorus flux* (SPF), measuring the external phosphorus input and the total amount of phosphorus transported by advective and wind-induced water flows;
- (iii) *Compartment fluxes of phosphorus* (CF_i), measuring the amounts of phosphorus transferred through each compartment by internal transformation mechanisms and input from all external sources;
- (iv) *Total phosphorus flux* (CF_{TP}), the sum of flows for all phosphorus compartments.

Information on external input-output phosphorus fluxes, based on an improved model representation of watershed phosphorus loading as well as on direct measurements on Zala river discharge water in 1976–1979, is summarized in Table 16. The external input fluxes taken into account here are:

- (i) DIP from Zala river discharge water, watershed load (sewage, tributaries, urban runoff), rainfall load, and sediment load;
- (ii) DOP from rainfall;
- (iii) PD from Zala river discharge water, watershed load (tributaries and urban runoff), and sediment load;
- (iv) Phyto-P (F) and bacterial-P (B) from Zala river discharge water.

Examination of Table 16 shows that phosphorus is removed from the aqueous environment in all four basins by sedimentation and in Basin IV also by advective water flow. The estimated values for the total balance in external input-output fluxes show that it is stable and positive for Basin I as a result of the permanent inflow of phosphorus from the Zala river; for Basins II–IV it may be negative or close to zero, depending on the data or the hypothesis utilized to describe external phosphorus loading.

In quantitative terms, the total external phosphorus input for Basin I is 1.11–1.14 times larger than the output for the period 1976–1979. For Basins II–IV this ratio is 0.97–1.0 for the same years. Estimates of the total phosphorus balance for the whole lake show that in 1976 the external input flux was higher than the output flux by 67.6 kg P day⁻¹; in 1977 the output flux was 42.9 kg P day⁻¹ higher than the input, whilst in 1978 and 1979 the input and output fluxes were almost in balance, with net input fluxes of 6.7 and 0.6 kg P day⁻¹, respectively.

On the basis of the simulation results, it is possible to evaluate the dependence of the phosphorus cycle in each basin of the lake on each of the interactions considered in the model. The phosphorus flux through the entire system depends on the total flux across all of the phosphorus compartments and the extent and nature of coupling between the compartments. Table 17 compares estimates of each phosphorus compartment flux taken into account in the model. The ratios between compartment and external fluxes, also shown in Table 17, demonstrate the role of the various internal transformation processes in the overall

TABLE 16 Comparison of external input-output phosphorus fluxes^a for the four basins of Lake Balaton for 1976–1979, as calculated by the model.

Year and basin	Input fluxes (EF _i)						Output fluxes (OF _i)						Total P balance	EF _{TP} /OF _{TP}	
	DIP	DOP	PD	F	B	Total P	DIP	DOP	PD	F	B	Total P			
<i>1976</i>															
I	0.5569	0.0166	3.5775	0.0189	0.0009	4.1708	–	–	3.7445	–	–	3.7445	0.4256	1.11	
II	0.1310	0.0125	2.0827	–	–	2.2262	–	–	2.2390	–	–	2.2390	–0.0128	0.99	
III	0.1056	0.0111	1.6280	–	–	1.7447	–	–	1.7449	–	–	1.7449	–0.0002	1.00	
IV	0.0836	0.0102	1.2476	–	–	1.3416	0.0008	0.0016	1.3420	0.0013	0.0007	1.3464	–0.0060	1.00	
Whole lake ^b	628.3	58.4	8577.8	4.2	0.2	9268.9	1.8	3.5	9191.6	2.9	1.5	9201.3	67.6	1.01	
<i>1977</i>															
I	0.5413	0.0164	2.4325	0.0397	0.0011	3.0308	–	–	2.6960	–	–	2.6960	0.3351	1.12	
II	0.1154	0.0124	1.2686	–	–	1.3964	–	–	1.4310	–	–	1.4310	–0.0347	0.98	
III	0.0862	0.0110	0.9775	–	–	1.0747	–	–	1.0939	–	–	1.0939	–0.0192	0.98	
IV	0.0695	0.0101	0.7394	–	–	0.8190	0.0012	0.0015	0.8362	0.0013	0.0004	0.8406	–0.0215	0.97	
Whole lake ^b	546.6	58.0	5213.5	8.9	0.2	5827.2	2.6	3.3	5860.4	2.9	0.9	5870.1	–42.9	0.99	
<i>1978</i>															
I	0.6021	0.0144	2.8936	0.0217	0.0009	3.5327	–	–	3.1673	–	–	3.1673	0.3658	1.12	
II	0.1227	0.0108	1.5760	–	–	1.7095	–	–	1.7381	–	–	1.7381	–0.0286	0.98	
III	0.0846	0.0096	1.2202	–	–	1.3144	–	–	1.3249	–	–	1.3249	–0.0105	0.99	
IV	0.0671	0.0088	0.9276	–	–	1.0035	0.0005	0.0014	1.0106	0.0017	0.0011	1.0153	–0.0117	0.99	
Whole lake ^b	560.6	50.5	6477.5	4.9	0.2	7093.7	1.1	3.1	7076.7	3.7	2.4	7087.0	6.7	1.00	
<i>1979</i>															
I	0.7960	0.0159	3.1525	0.0265	0.0014	3.9923	–	–	3.4851	–	–	3.4851	0.5078	1.14	
II	0.1640	0.0119	1.6006	–	–	1.7765	–	–	1.8159	–	–	1.8159	–0.0394	0.98	
III	0.1041	0.0106	1.2245	–	–	1.3392	–	–	1.3590	–	–	1.3590	–0.0198	0.98	
IV	0.0793	0.0098	0.9205	–	–	1.0096	0.0009	0.0018	1.0207	0.0017	0.0011	1.0262	–0.0166	0.98	
Whole lake ^b	709.8	56.0	6554.9	5.9	0.3	7326.9	2.0	3.9	7314.3	3.7	2.4	7326.3	0.6	1.00	

^aIn units of mg P l⁻¹ year⁻¹, unless otherwise specified.

^bIn units of kg P day⁻¹.

TABLE 17 Comparison of phosphorus fluxes^a determined by internal cycling within Lake Balaton for 1976–1979.

Year and basin	Compartment fluxes (CF _i)						System phosphorus flux (SPF)	Flux ratios (CF _i /EF _i)				CF _{TP} /SPF	SPF/EF _{TP}
	DIP	DOP	PD	F	B	Total-P		DIP	DOP	PD	Total-P		
<i>1976</i>													
I	0.8562	0.6465	4.4137	0.7977	0.5131	7.2272	4.5571	1.5	38.9	1.2	1.73	1.58	1.09
II	0.3742	0.4240	2.6207	0.3970	0.3957	4.2116	2.5246	2.9	33.9	1.3	1.89	1.67	1.13
III	0.2931	0.3442	2.0449	0.3059	0.3323	3.3204	1.9115	2.8	31.0	1.3	1.90	1.74	1.10
IV	0.2402	0.2832	1.5715	0.2460	0.2819	2.6228	1.3931	2.9	27.8	1.3	1.96	1.88	1.04
Whole lake ^b	1625.3	1813.1	10771.4	1671.7	1728.6	17610.2	10283.5	2.6	31.0	1.3	1.90	1.71	1.11
<i>1977</i>													
I	0.7524	0.4410	3.0482	0.7080	0.3572	5.3068	3.2550	1.4	26.9	1.2	1.75	1.63	1.07
II	0.2742	0.2651	1.6277	0.2907	0.2487	2.7064	1.5635	2.4	21.4	1.3	1.94	1.73	1.12
III	0.2030	0.2100	1.2464	0.2129	0.2032	2.0755	1.1619	2.3	19.1	1.3	1.93	1.79	1.08
IV	0.1688	0.1789	0.9582	0.1746	0.1780	1.6585	0.8488	2.4	17.7	1.3	2.02	1.95	1.04
Whole lake ^b	1183.9	1137.4	6680.8	1221.6	1086.7	11310.5	6975.4	2.2	19.6	1.3	1.94	1.80	1.08
<i>1978</i>													
I	0.7858	0.4454	3.5243	0.7074	0.2922	5.7551	3.7659	1.3	30.9	1.2	1.63	1.53	1.07
II	0.2569	0.2408	1.9032	0.2703	0.1917	2.8629	1.8853	2.1	22.3	1.2	1.67	1.52	1.10
III	0.1713	0.1737	1.4462	0.1798	0.1479	2.1189	1.4016	2.0	18.1	1.2	1.61	1.51	1.07
IV	0.1389	0.1338	1.0991	0.1417	0.1257	1.6392	1.0319	2.1	15.2	1.2	1.63	1.59	1.03
Whole lake ^b	1054.0	952.1	7737.6	1071.8	801.8	11617.1	7550.5	1.9	18.8	1.2	1.64	1.54	1.06
<i>1979</i>													
I	1.1666	0.7752	4.1350	1.0572	0.6189	7.7529	4.3471	1.5	48.7	1.3	1.94	1.78	1.09
II	0.4406	0.4592	2.1659	0.4592	0.4305	3.9554	2.0315	2.7	38.6	1.3	2.23	1.95	1.14
III	0.2987	0.3490	1.6303	0.3137	0.3393	2.9310	1.4677	2.9	32.9	1.3	2.19	2.00	1.10
IV	0.2367	0.2855	1.2372	0.2441	0.2834	2.2869	1.0492	3.0	29.1	1.3	2.26	2.18	1.04
Whole lake ^b	1771.7	1894.7	8778.1	1809.1	1806.5	16060.3	7993.4	2.5	33.8	1.3	2.19	2.01	1.09

^aIn units of mg P l⁻¹ year⁻¹, unless otherwise specified.

^bIn units of kg P day⁻¹.

phosphorus cycle. For example the ratio for DIP, CF_{DIP}/EF_{DIP} , was fairly constant at 1.3–1.5 throughout the period studied in Basin I, where the role of external sources in total DIP load is much more important than in the other basins. For Basins II–IV the ratio CF_{DIP}/EF_{DIP} varied from 2.3 to 3.0 in 1976, 1977, and 1979 and from 2.0 to 2.1 in 1978. For DOP the role of internal cycling was assumed to be much more significant than the external load, because only a single external source, rainfall, was taken into account; the ratio CF_{DOP}/EF_{DOP} ranged from 15.2 to 48.7 for Basins I–IV during the period studied. The ratio CF_{PD}/EF_{PD} was quite stable at 1.2–1.3 for all the basins throughout the period. For total phosphorus the ratio was more or less constant at 1.75–2.02 in 1976 and 1977; in 1978 it decreased to 1.61–1.67, while in 1979 it increased again to 1.94–2.26.

The ratio CF_{TP}/SPF indicates the role in the phosphorus cycle of chemical and biological transformation as compared to external phosphorus loading and the effects of hydrodynamic transport. This ratio varied within the ranges 1.6–1.9 for 1976 and 1977, 1.5–1.6 for 1978, and 1.8–2.2 for 1979.

Finally, the ratio SPF/EF_{TP} evaluates the contribution of hydrodynamic transport of total phosphorus in the overall phosphorus loading for each basin of Lake Balaton. This ratio varied only within relatively narrow ranges during the period studied, namely 1.07–1.09, 1.1–1.14, 1.07–1.1, and 1.03–1.04 for Basins I–IV, respectively.

6.4. Phosphorus Turnover Times

It is known (Pomeroy 1970) that a better understanding of the phosphorus cycling in a given system may be obtained by analyzing the turnover times of total phosphorus and individual phosphorus fractions. In the case of Lake Balaton, the study of phosphorus cycling as a key element in the eutrophication of the lake is of major importance in explaining observed features of the phosphorus budget and determining the functioning of the lake ecosystem. Preliminary assessments of phosphorus turnover times for Lake Balaton were made on the basis of an intermediate model version of watershed phosphorus loading (Leonov 1982); in the present report, the phosphorus turnover times are evaluated using later, improved data on external phosphorus loads.

Because assessments of turnover times and flux rates strongly depend upon model structure and the coupling between the model compartments (Watson and Loucks 1979), all instantaneous internal *and* external phosphorus fluxes were considered when calculating instantaneous turnover times for individual phosphorus compartments; in contrast, only external instantaneous flows were taken into account when estimating the turnover time for total phosphorus. Turnover times were calculated for each time step during the numerical solution of the model equations by the computer. Instantaneous pool sizes for each of the phosphorus compartments were divided by instantaneous input–output flux rates through the pool concerned, to obtain instantaneous turnover times. Then, the values of turnover times calculated in this way were averaged over daily, monthly, and annual periods.

Analysis of the daily mean turnover times for the various phosphorus fractions shows that:

- (i) All of the phosphorus fractions are much more mobile in Basin I than in the other basins;
- (ii) Amplitudes of turnover-time fluctuations, as well as the seasonal differences in turnover time values for F, DIP, and DOP, increase from Basin I to Basin IV; this is caused by the varied phosphorus loadings and phosphorus concentrations in different parts of the lake water and the consequent variations in phytoplankton activity in different basins of the lake;
- (iii) Variations in turnover times for all phosphorus fractions are much less pronounced in summer than in other seasons for each of the years between 1976 and 1979.

The turnover time of system total phosphorus was also calculated as an instantaneous measure, by dividing the average pool size of total phosphorus in the system by the sum of the external flux rates for every time step considered. Consequently the instantaneous turnover time of system total phosphorus does not take into account internal phosphorus interconversion; it is based on combined data, namely model output data (or temporary levels of system total phosphorus) and empirical observations (all external phosphorus inputs to the lake).

Seasonal and annual mean values of the turnover times evaluated by the model for each year studied are summarized in Table 18. Values of the standard deviations of the phosphorus compartment turnover times are also presented in the same table. The following general conclusions may be drawn.

The turnover of phosphorus pools appears to be fastest for the biological compartments, bacteria and phytoplankton, and in the inanimate particulate organic-P compartment, which is directly dependent on microorganism activity and strongly influenced by environmental factors, primarily the wind. In the summer season, phosphorus turnover is accelerated so that both the differences in the values of phosphorus turnover times and their standard deviations are significantly reduced; the phosphorus turnover in all compartments, except that for inanimate particulate organic-P, is much more variable during the winter months than in the spring, autumn, and especially the summer.

The phosphorus pool in the phytoplankton compartment turns over during autumn and winter in approximately 7–10, 10–15, 12–17, and 15–20 days in Basins I–IV, respectively. In the spring and summer, the biomass of phytoplankton-P turns over somewhat more quickly, with turnover times of 4–7 days (Basin I), 6–8 days (Basin II), and 7–11 days (Basins III and IV). The standard deviations in phytoplankton-P turnover time can fluctuate in the ranges 3–5 days (winter) and 1–2 days (summer) as a result of changes in environmental factors and phosphorus loading. The annual mean turnover time of phytoplankton-P for the period 1976–1979 was approximately 7, 10, 12, and 14 days for Basins I–IV, respectively. The annual mean standard deviation of phytoplankton-P turnover time was 3, 4, 4.4, and 6 days for the same basins. The order of magnitude of the turnover times for phytoplankton-P calculated here appears to be in agreement with those estimated by Gächter (1968).

In the spring and summer months, the bacterial-P pool exhibits a turnover time on the order of 3–6 days in all four basins. During the autumn and winter, the turnover of bacterial-P becomes slower, with times of 6–12 days. The standard deviations of bacterial-P turnover time lie in the ranges 0.6–1.4 days

TABLE 18 Seasonal and annual mean phosphorus turnover times (μ) and standard deviations (σ) (both in days), as evaluated by the model for 1976–1979.

Year	Basin	Form of phosphorus	Winter, Jan–Mar		Spring, Apr–Jun		Summer, Jul–Sep		Autumn, Oct–Dec		Annual mean	
			μ	σ	μ	σ	μ	σ	μ	σ	μ	σ
1976	I	F	9.0	3.2	5.9	1.8	5.3	1.5	8.5	2.8	7.1	2.9
		B	7.1	1.1	4.2	1.0	4.5	0.8	7.3	1.4	5.7	1.8
		PD	2.1	0.7	2.0	0.6	1.9	0.5	2.1	0.5	2.0	0.6
		DOP	25.6	15.0	16.1	12.6	6.3	1.3	12.3	6.3	15.0	12.4
		DIP	14.5	6.5	4.1	3.5	2.8	1.4	10.4	7.8	7.9	7.2
		TP	5.7	2.8	6.3	2.6	8.5	3.6	4.9	1.8	6.4	3.1
	II	F	12.4	4.3	8.0	2.4	6.6	1.7	11.4	3.6	9.6	4.0
		B	8.1	0.8	4.7	1.0	5.2	0.9	8.9	1.4	6.7	2.1
		PD	2.8	0.9	2.6	0.8	2.4	0.6	2.7	0.7	2.6	0.8
		DOP	48.0	23.2	20.4	17.2	6.0	1.0	13.1	7.0	21.7	21.7
		DIP	17.6	8.3	4.0	3.9	2.7	1.3	11.3	8.9	8.9	8.7
		TP	6.5	2.8	7.8	3.2	10.7	4.7	5.7	2.1	7.7	3.8
	III	F	14.3	4.7	9.4	2.9	7.4	2.0	12.5	4.1	10.9	4.5
		B	8.5	0.6	5.0	1.0	5.5	1.0	9.4	1.4	7.1	2.2
		PD	3.2	1.0	3.0	0.9	2.7	0.7	3.1	0.8	3.0	0.9
		DOP	50.8	24.0	20.8	17.8	5.8	1.0	13.9	6.9	22.6	22.8
		DIP	17.9	7.4	3.9	3.4	2.7	1.2	11.3	7.5	8.9	8.3
		TP	6.9	2.8	8.5	3.4	12.0	5.2	6.7	2.4	8.5	4.2
	IV	F	18.2	5.7	11.2	3.9	7.9	2.2	15.6	4.9	13.2	5.9
		B	9.2	0.3	5.3	1.0	5.8	1.1	10.7	1.6	7.8	2.5
PD		3.7	1.2	3.5	1.1	3.0	0.9	3.6	0.9	3.4	1.0	
DOP		66.0	23.9	21.1	17.7	6.0	1.0	19.9	6.9	26.5	27.7	
DIP		18.9	7.8	3.8	3.1	2.8	1.2	11.4	7.7	9.2	8.7	
TP		7.1	2.7	9.4	3.9	14.6	5.9	7.2	2.6	9.6	5.0	
1977	I	F	7.7	2.5	6.3	1.8	5.9	1.6	9.1	3.3	7.2	2.7
		B	6.8	1.1	4.6	1.3	5.1	0.8	7.8	1.3	6.1	1.7
		PD	2.1	0.5	2.0	0.5	1.9	0.5	2.2	0.7	2.1	0.6
		DOP	24.2	12.5	18.5	14.4	5.9	1.4	15.4	9.7	16.0	12.6
		DIP	14.3	6.7	3.9	2.6	2.7	1.3	12.7	10.2	8.3	8.0
		TP	5.1	1.7	7.4	3.5	11.0	4.5	7.3	3.0	7.7	4.0
	II	F	11.4	3.9	9.0	2.6	7.9	2.0	12.6	4.2	10.2	3.8
		B	7.9	1.1	5.2	1.4	6.0	1.0	9.6	1.0	7.2	2.1
		PD	2.8	0.8	2.6	0.8	2.4	0.7	2.9	1.0	2.7	0.8
		DOP	37.2	17.0	24.8	23.0	5.3	1.0	14.0	9.1	20.2	19.2
		DIP	18.1	9.5	4.0	2.9	2.7	1.2	11.9	10.4	9.1	9.5
		TP	6.8	2.3	9.6	4.7	13.6	6.1	7.1	3.1	9.3	5.1
	III	F	12.9	4.2	10.5	3.1	8.9	2.2	13.9	4.8	11.6	4.2
		B	8.3	1.1	5.6	1.4	6.4	1.1	10.1	1.1	7.6	2.1
		PD	3.1	0.9	3.0	0.9	2.7	0.8	3.3	1.1	3.0	0.9
		DOP	39.0	15.8	25.8	24.6	5.2	1.0	14.2	8.6	20.9	19.8
		DIP	18.3	9.0	4.0	2.8	2.6	1.2	11.5	8.8	9.0	9.0
		TP	7.5	2.5	10.4	5.1	15.1	6.9	8.0	3.5	10.3	5.7
	IV	F	15.9	4.9	12.2	4.2	9.0	2.2	17.7	5.7	13.7	5.6
		B	8.7	1.1	5.9	1.5	6.6	1.2	11.3	0.8	8.1	2.4
PD		3.7	1.1	3.4	1.1	3.0	0.8	3.8	1.3	3.5	1.1	
DOP		42.7	13.5	27.6	26.3	5.3	1.0	14.1	8.8	22.3	20.9	
DIP		18.4	9.3	3.9	2.8	2.6	1.2	11.5	8.8	9.1	9.1	
TP		7.7	2.5	11.6	5.6	17.9	7.1	8.1	3.4	11.3	6.4	

TABLE 18 *Continued.*

Year	Basin	Form of phosphorus	Winter, Jan-Mar		Spring, Apr-Jun		Summer, Jul-Sep		Autumn, Oct-Dec		Annual mean	
			μ	σ	μ	σ	μ	σ	μ	σ	μ	σ
1978	I	F	8.8	3.5	5.9	1.8	6.0	1.7	9.6	3.2	7.6	3.1
		B	7.3	1.3	4.5	1.1	5.4	0.9	8.4	1.2	6.4	1.9
		PD	2.2	0.7	2.0	0.4	2.0	0.5	2.2	0.6	2.1	0.6
		DOP	28.0	16.4	18.9	10.8	6.2	1.6	20.9	10.4	18.4	13.6
		DIP	18.2	9.6	3.9	2.6	2.9	1.4	16.3	10.5	10.3	10.1
	TP	6.0	2.4	6.0	2.2	8.1	2.7	7.6	2.7	6.9	2.6	
	II	F	11.5	4.1	8.5	2.4	8.4	2.2	13.6	4.4	10.5	4.0
		B	8.3	1.2	5.2	1.2	6.5	1.1	10.2	1.4	7.6	2.2
		PD	2.9	1.0	2.6	0.7	2.6	0.7	2.9	0.9	2.8	0.8
		DOP	36.2	18.7	23.0	15.5	5.4	1.2	17.5	8.5	20.4	16.9
		DIP	19.6	11.6	3.7	2.4	2.8	1.3	15.6	10.8	10.4	10.8
	TP	6.1	2.4	7.8	3.3	9.7	3.5	6.9	2.7	7.7	3.3	
	III	F	13.5	4.7	10.3	2.9	9.9	2.6	14.9	4.9	12.1	4.4
		B	8.7	1.2	5.5	1.2	7.0	1.2	10.6	1.3	8.0	2.2
		PD	3.3	1.2	3.0	0.8	3.0	0.8	3.3	1.0	3.1	1.0
		DOP	38.1	18.0	22.5	15.9	5.3	1.1	19.0	8.8	21.1	17.3
		DIP	19.0	9.6	3.7	2.2	2.7	1.3	16.1	9.6	10.3	10.0
	TP	6.3	2.4	8.2	3.5	10.5	3.9	7.8	3.0	8.2	3.6	
	IV	F	17.6	5.8	12.0	3.9	9.9	2.6	19.3	6.2	14.7	6.2
		B	9.5	1.2	5.8	1.3	7.2	1.2	12.3	1.8	8.7	2.8
PD		3.9	1.4	3.5	1.0	3.3	0.9	3.8	1.2	3.6	1.1	
DOP		41.4	16.0	23.2	16.6	5.4	1.2	16.5	7.2	21.5	17.8	
DIP		19.0	9.7	3.6	2.2	2.7	1.2	15.2	9.0	10.1	9.8	
TP	6.3	2.3	9.2	4.2	12.7	4.3	7.5	3.1	8.9	4.3		
1979	I	F	8.2	3.3	5.7	1.7	4.9	1.4	8.4	2.7	6.8	2.8
		B	6.8	1.2	4.0	0.6	4.3	0.7	7.9	1.1	5.8	1.9
		PD	2.2	0.7	2.0	0.6	1.9	0.5	2.1	0.5	2.0	0.6
		DOP	26.8	15.7	16.5	12.7	6.4	1.2	18.6	9.7	17.0	13.3
		DIP	18.4	9.8	3.3	2.0	2.7	1.2	13.3	7.9	9.4	9.2
	TP	7.4	3.4	8.5	4.2	10.0	3.9	7.2	2.6	8.3	3.7	
	II	F	10.7	3.9	8.0	2.4	6.5	1.7	12.1	3.8	9.3	3.8
		B	7.8	1.2	4.6	0.6	5.1	0.8	9.7	1.2	6.8	2.3
		PD	2.9	1.0	2.6	0.9	2.4	0.7	2.8	0.8	2.7	0.9
		DOP	39.2	21.4	19.7	17.2	5.9	0.8	16.2	8.5	21.0	18.7
		DIP	20.9	12.4	3.1	1.8	2.6	1.1	12.9	8.4	9.8	10.6
	TP	8.2	3.8	11.1	5.7	12.9	5.7	7.2	2.9	9.9	5.2	
	III	F	12.8	4.3	9.4	2.9	7.4	1.9	13.7	4.4	10.8	4.4
		B	8.2	1.2	4.8	0.5	5.5	0.8	10.4	1.2	7.2	2.4
		PD	3.3	1.1	2.9	1.0	2.7	0.8	3.2	0.9	3.0	1.0
		DOP	41.4	20.0	18.6	15.9	5.4	0.7	16.1	7.7	20.3	18.7
		DIP	19.3	10.1	3.0	1.5	2.5	1.1	13.0	7.7	9.4	9.5
	TP	7.8	3.3	11.9	6.3	14.3	6.5	7.9	3.2	10.5	5.8	
	IV	F	16.8	5.3	11.1	4.0	7.8	2.0	17.5	5.7	13.3	6.0
		B	8.7	1.1	5.0	0.6	5.8	0.8	11.7	1.5	7.8	2.8
PD		3.9	1.4	3.6	1.3	3.0	0.9	3.7	1.1	3.5	1.2	
DOP		46.3	18.0	18.0	14.6	5.5	0.7	15.1	7.1	21.1	19.4	
DIP		18.7	9.6	2.9	1.5	2.6	1.1	12.6	7.5	9.2	9.1	
TP	7.5	3.0	13.1	7.1	17.1	7.0	8.0	3.4	11.4	6.8		

(Basin I), 0.4–1.7 days (Basins II and III), and 0.2–2.0 days (Basin IV) for the autumn and winter months, while in spring and summer these estimates are reduced to 0.1–1.3 days for all four basins. Changes in bacterial-P turnover time from day to day are essentially the same in all four basins, and the amplitudes are estimated as 2–3 days, regardless of season. Annual mean values of bacterial-P turnover appear to be about 6–8 days in the Lake Balaton ecosystem.

Inanimate particulate organic-P exhibits daily mean turnover times of 0.6–4.2, 0.7–5.3, 0.7–5.9, and 0.8–6.8 days in Basins I through IV, respectively. Daily fluctuations of detrital-P in shallow water bodies are to a large extent dependent on the sediment–water interactions with respect to phosphorus exchange. The rapid circulation of detrital-P is strongly influenced by the action of wind, which was the subject of specific attention in our study. According to the simulation results, during strong winds (i.e. those of more than $8\text{--}10\text{ m s}^{-1}$) the turnover time of detrital-P is shortest, while it appears to be longest when light winds prevail. The annual mean values of turnover times for detrital-P were evaluated as 2.1, 2.7, 3.0, and 3.5 days for Basins I–IV, respectively. The annual mean standard deviations of detrital-P turnover times were found to be 0.575, 0.827, 0.952, and 1.127 days for the same basins. The seasonal variations show a slight lowering of the detrital-P turnover time in the summer months, manifested more strongly in Basins III and IV than in Basins I and II. The assessments of turnover times for detrital-P obtained in this study may not be completely analogous with those in the literature because of the great variety of model structures and functions used here and elsewhere to describe the dynamic behavior of the detrital-P. For example, Watson and Loucks (1979) estimated a turnover time of 10 days for suspended detrital-P, but without taking into account the effect of wind on phosphorus exchange in the sediment–water layer.

The dynamics of DOP turnover show marked seasonal trends in all four basins. During the winter and spring, the turnover time fluctuates in relatively wide ranges – 4.4–79.3 days (Basin I), 4.3–119.4 days (Basin II), 4.0–122.8 days (Basin III), and 4.4–121.5 days (Basin IV). In the summer months, the DOP turnover time fluctuates much less, because of the higher microorganism activity, which significantly accelerates internal phosphorus cycling through compartments. The mean turnover times for the summer period are 5–8 days (with standard deviations of 0.6–2.3 days) for the different basins of Lake Balaton during 1976–1979. The annual mean values of DOP turnover time fluctuate for individual years in the ranges 15.0–18.4 (Basin I), 20.1–21.7 (Basin II), 20.3–22.7 (Basin III), and 21.1–26.5 days (Basin IV). The corresponding standard deviations are 12.4–13.6, 16.9–21.7, 17.3–22.8, and 17.8–27.7 days for the same basins.

The turnover of DIP is almost identical in all four basins during the period 1976–1979. In the winter and spring months, the turnover time lies in the ranges 3.1–19.4 days (Basin I), 2.6–24.0 days (Basin II), 3.1–21.6 days (Basin III), and 2.8–24.2 days (Basin IV). The corresponding values for the summer months are between 2.2 and 2.7 days in all four basins. According to the simulation results the turnover of DIP in the summer months is very rapid, indicating the limiting phosphate conditions and the high level of microorganism activity. Because, as observed, the phosphate levels are more or less equal at $0.004\text{--}0.006\text{ mg P l}^{-1}$ in the different basins during the summer, the assessment of DIP turnover time makes it possible to arrive at better estimates of the equilibrium between all the processes responsible for phosphate levels in the waters of Lake Balaton. The

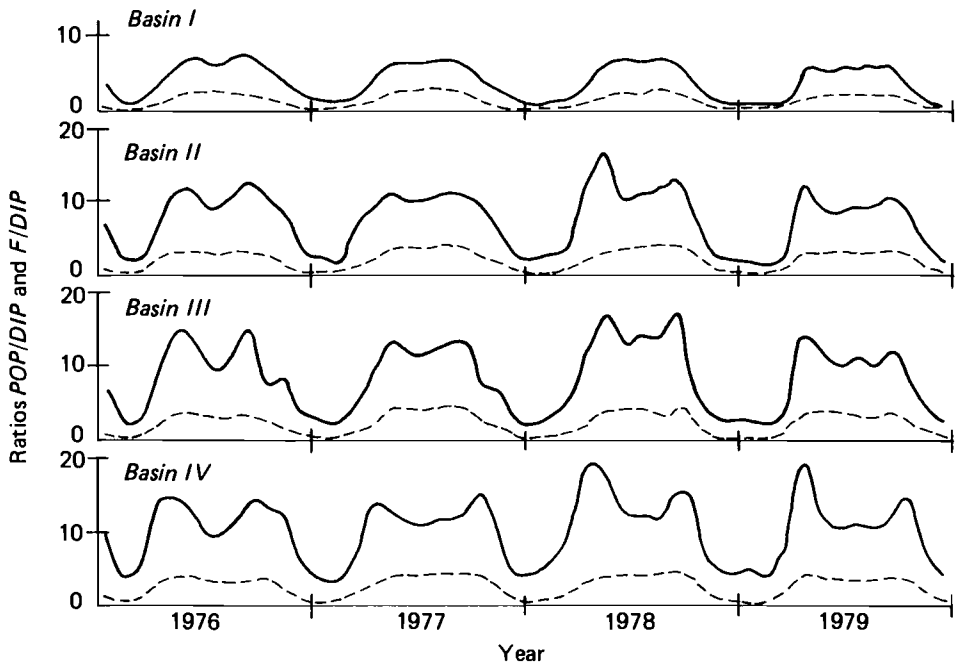

FIGURE 7 Dynamics of the concentration ratios POP/DIP (—) and F/DIP (---), Lake Balaton Basins I-IV, 1976-1979.

seasonal development of the turnover time for DIP evaluated by the model suggests that rapid DIP fluxes are typical of the summer months, during the period of high microorganism activity, and that input-output flux rates through this compartment are even more important than absolute levels of DIP in maintaining the high rates of organic production and phosphorus conversion as a whole in the lake. DIP turnover in the Lake Balaton ecosystem may be further explained through analysis of the ratio of particulate phosphorus fractions to DIP. Three particulate phosphorus compartments (inanimate particulate organic-P, bacterial-P, and phytoplankton-P) were considered in the model, and two ratios – total particulate organic-P (including all the particulate-P compartments) to DIP and phytoplankton-P to DIP – were computed on the basis of the monthly mean phosphorus concentrations obtained in the simulation runs. The first ratio, POP/DIP, shows the dominance of particulate phosphorus as the most important and mobile fraction in the phosphorus pool as a whole, while the second ratio shows the seasonal changes in the phosphate requirements of phytoplankton or, in other words, the dynamics of the phosphate limiting process. Figure 7 illustrates the seasonal changes of these ratios in the different basins of Lake Balaton during the years 1976-1979. Thus, in Basin I the level of particulate organic-P is approximately 5.0-7.5 times higher than that of DIP during the summer months. In Basins II-IV the POP level is 9-19 times greater than that of DIP for the same period. This means that phosphate limitation is more pronounced in Basins II-IV than in Basin I. The range of the phytoplankton-P to DIP ratio in the summer months during 1976-1979 is 2.3-3.0 for Basin I, but it is higher in other parts of the lake, where

it lies in the range 3.5–5.0. During the winter period, when the role of the living components of the particulate organic-P appears to be less important and the DIP content of the water tends to be higher than in the summer, these ratios differ from each other by only 1–3 times (Basin I) and 2–5 times (Basins II–IV).

As mentioned above, the order of magnitude of the DIP turnover time in existing assessments is dependent on the measurement or calculation techniques used, and the available estimates are not always directly comparable with each other (Leonov 1982). However, the assessments of phosphate turnover time made by Patten *et al.* (1975) and Watson and Loucks (1979) and those made in this study for the summer period show reasonable agreement with one another.

The turnover time of total phosphorus is defined by the external phosphorus fluxes and primarily by the inanimate particulate organic-P and DIP levels, since according to our hypothesis, the role of other phosphorus compartments in the external phosphorus load is not very important. The role of internal phosphorus cycling in the turnover of total phosphorus is essential only for the regulation of the intermediate concentrations of individual compartments within the phosphorus system. According to the available data and the simulation results, the annual changes in total phosphorus concentrations are very specific to each basin, and ranges of possible annual fluctuations of total phosphorus are estimated as 0.03–0.14, 0.02–0.09, 0.015–0.08, and 0.012–0.07 mg P l⁻¹ in Basins I–IV, respectively. At the same time, there is a certain trend common to all the basins in the annual changes of total phosphorus, namely a slight but noticeable progressive increase in total phosphorus levels during the productive seasons in each of the years 1976–1979.

It is reasonable to assume that the actual equilibrium between all the processes responsible for the phosphorus levels in the lake water constantly varies within each year. This feature of the annual dynamics of total phosphorus is to a large degree illustrated by examination of total phosphorus turnover time, which may fluctuate by an order of magnitude within a given season. For example, in the winters from 1976–1979, the turnover time of total phosphorus fluctuates from 1.2 to 19.2 days (Basin I), from 1.5 to 21.7 days (Basin II), from 1.6 to 18.7 days (Basin III), and from 1.5 to 16.5 days (Basin IV). In the spring and autumn months the corresponding ranges were estimated as 1.4–19.9, 1.5–32.4, 2.0–35.8, and 2.1–40.3 days, for the same basins. For the summer period, the turnover time ranges were 1.8–25.1, 1.7–34.2, 1.7–39.0, and 2.4–42.7 days for Basins I through IV, respectively. Analysis of the monthly mean turnover times for total phosphorus for 1976–1979 shows that in Basin I the turnover is shortest in January (3.5–6.5 days, mean 5.2 days) and in April (4.8–6.4 days, mean 5.5 days). In Basins II–IV the shortest turnover times were observed for November, December, and January, with mean turnover times of 6, 6.6, and 6.7 days, respectively. According to model calculations, July and August are characterized by increased turnover times for total phosphorus, with mean times of 10 days (range 8.2–12.5 days), 12.6 days (10.2–15.7 days), 14 days (11–17.6 days), and 16.8 days (13.2–20.4 days) for Basins I–IV, respectively. This increase in the turnover time during the summer period may be explained primarily by the significant reduction in external phosphorus loading (see Table 12) and by some increase in the total phosphorus concentrations in the lake water caused by intensified biological processes in the overall phosphorus transformation within the water body. The fluctuations of the turnover time for total phosphorus within the summer period depend principally

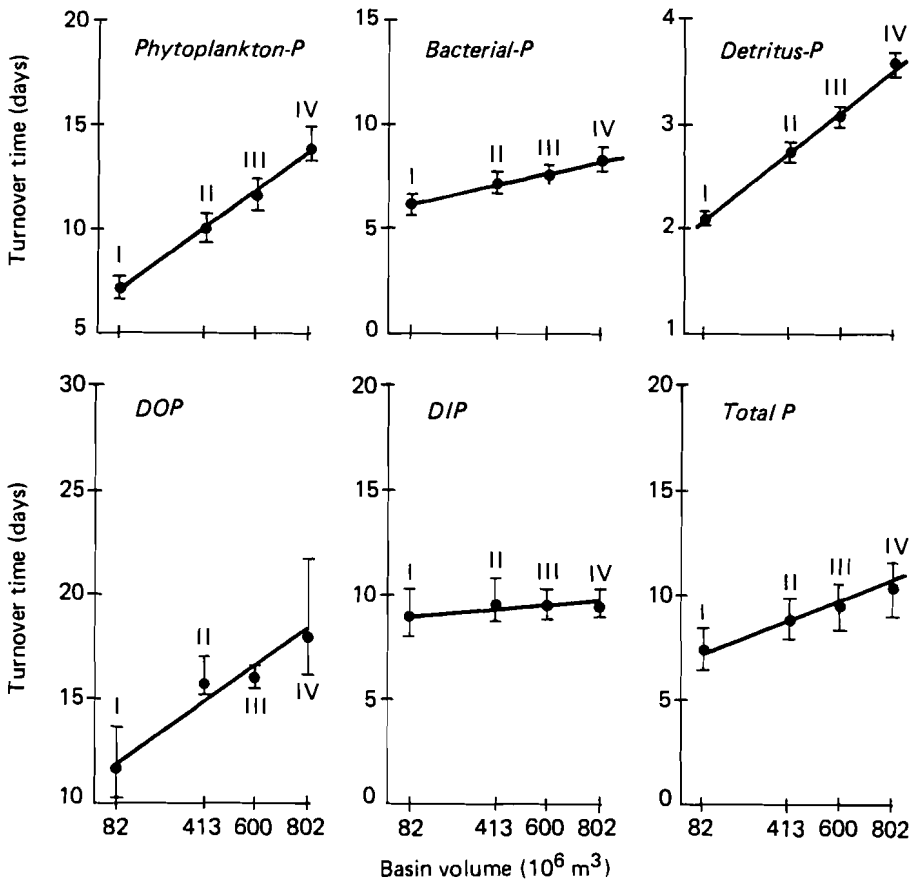

FIGURE 8 Dependence of phosphorus compartment turnover time on basin water volume, Lake Balaton Basins I-IV, *average* for 1976-1979.

on the rapid, wind-regulated phosphorus exchange through the sediment-water interface, while the effect of the other processes in the phosphorus supply is considered to be extremely low.

Analysis of the turnover times for each phosphorus compartment considered in this study shows that, for the environmental conditions obtaining in 1976-1979, the annual phosphorus circulation in Lake Balaton exhibited no significant variation from year to year. The model calculations indicate that the annual mean values of the phosphorus turnover times throughout the four-year period are essentially functions of the basin volumes. Figure 8 shows the annual mean turnover times of the individual phosphorus compartments and that for total phosphorus as functions of the water volumes of each basin. The range of fluctuations in these estimated turnover times is also shown in the figure. It is clear from Figure 8 that there appears to be a linear dependence of annual mean turnover time on basin volume for all the phosphorus compartments. Application of more recent, improved information on external phosphorus loading seems to indicate that the corresponding dependences for the chemical compartments, DIP and DOP, are also

linear, in contrast to our earlier conclusions, which were based on a less sophisticated representation of external phosphorus loading (Leonov 1982).

On the basis of these model calculations of annual phosphorus turnover times, we therefore conclude that the conditions of phosphorus circulation are similar in the different parts of Lake Balaton and that the actual turnover times for individual phosphorus compartments are functions of the volume of the basin considered. Some differences in phosphorus turnover for individual seasons within the years 1976–1979 were noted as a result of annual changes in weather conditions and external loading (see Table 18). Model calculations show that the largest differences in turnover times occurred in the winter, while the smallest differences were noted for the summer period.

7. MODELING OF PHOSPHORUS LOAD CHANGE

The principal objective of IIASA's Lake Balaton Case Study was the analysis of the lake's response to changes, whether reductions or increases, in the overall phosphorus load, because phosphorus is generally agreed to be the main eutrophication-control factor for the Lake Balaton ecosystem. The analysis was intended to identify any simple correlations that may exist between phosphorus loading and biological and chemical responses in the water body, as measured by changes in phosphorus compartment levels as well as phosphorus flows from one compartment to another. It is hoped that knowledge of these interrelationships will improve our understanding of the quantitative links between phosphorus supply and resultant phosphorus concentrations in the lake water and help to explain the major phosphorus flows in the aquatic system, thus providing a basis for sound water quality management.

Preliminary applications of BALSECT to questions of water quality management were reported by Kindler (1981). In the present study the model was used to examine the lake's response to phosphorus load changes along lines suggested by Laszlo Somlyódy (IIASA internal memoranda and personal communications).

Simulations of phosphorus load change were conducted by running the model with varying phosphorus load contributions from the Zala river, first because it is the primary source of the phosphorus that reaches the lake and second because, in this study, the river is considered to be a controllable factor in Lake Balaton eutrophication.

The annual distribution of Zala river discharge rates was evaluated on the basis of the data available for 1973–1978, while the monthly mean values of Zala river flow rates presented in Table 19 were used in the phosphorus load-change simulations. Using simple regression analysis, relationships were established between monthly average Zala river phosphorus loads (for total phosphorus and orthophosphate-P separately) in kg P day⁻¹ and monthly Zala river discharge rates in m³ s⁻¹. These relations are, respectively

$$L_{TP} = 71 + 11.4 \cdot Q^{1.3} \quad (20)$$

$$L_{PO_4} = 31 + 23.5 \cdot Q^{0.5} \quad (21)$$

TABLE 19 Monthly average Zala river discharge flow rates used in the load-change simulations.

Month	$Q(\text{m}^3 \text{s}^{-1})$	Month	$Q(\text{m}^3 \text{s}^{-1})$
January	11.4	July	6.0
February	11.6	August	3.7
March	12.4	September	3.7
April	7.7	October	6.1
May	7.2	November	8.2
June	7.3	December	9.4

TABLE 20 Values of reduction coefficients (ϵ) and phosphorus loads of Basin I used in the load-change simulations.

ϵ	Total-P load		DIP load		PD load	
	$\text{mg P l}^{-1} \text{ year}^{-1}$	kg P day^{-1}	$\text{mg P l}^{-1} \text{ year}^{-1}$	kg P day^{-1}	$\text{mg P l}^{-1} \text{ year}^{-1}$	kg P day^{-1}
1.00	1.077	241.7	0.427	95.9	0.607	136.5
0.25	0.269	60.5	0.107	24.0	0.120	27.0
0.50	0.538	121.0	0.213	47.9	0.283	63.5
0.75	0.808	181.4	0.320	71.9	0.445	100.0
1.50	1.615	362.9	0.604	143.9	0.932	209.5
2.00	2.111	474.4	0.854	191.8	1.215	273.5

Equations (20) and (21) were used in phosphorus load-change simulations to calculate the overall phosphorus loads per unit of basin volume

$$TP_Z = \epsilon \cdot L_{TP} \cdot 10^3 / V_1 \quad (22)$$

$$DIP_Z = \epsilon \cdot L_{PO_4} \cdot 10^3 / V_1 \quad (23)$$

$$PD_Z = TP_Z - DIP_Z - \Sigma P_{liv} \quad (24)$$

where TP_Z , DIP_Z , and PD_Z are Zala river loads for total phosphorus, DIP, and PD, respectively in $\text{mg P l}^{-1} \text{ day}^{-1}$, ϵ is a reduction coefficient (dimensionless), and ΣP_{liv} is the phosphorus load of the living biological compartments, primarily phytoplankton and bacterial (both in $\text{mg P l}^{-1} \text{ day}^{-1}$). ΣP_{liv} was in fact assumed in all runs to be equal to its 1977 values (see Table 12).

In the simulation runs, the reduction coefficient ϵ varied in the range 0.25–2.0* (Table 20), resulting in a variation in the total phosphorus load of Basin I from 0.269 to 2.111 $\text{mg P l}^{-1} \text{ year}^{-1}$ (60.5–474.4 kg P day^{-1}). Table 20 also shows the DIP and PD loads on Basin I, which are the major fractions of the Zala river phosphorus load. These values of the DIP and PD loads were used in the load-change simulations to calculate the external phosphorus loads from urban runoff for Basins I–IV, as was done earlier for the results from 1976–1979 (see Tables 4 and 5). Sewage and tributary phosphorus loads were taken unchanged from Tables 2 and 3, respectively. Note that the overall phosphorus loads of Basins II–IV were almost the same in all the load-change simulations.

Natural factors such as water temperature, solar radiation, and rates of water flow and precipitation were considered as noncontrollable factors in the

*At $\epsilon = 1$, the model represents the phosphorus load of an "average year".

load-change simulations. The annual dynamics of each of these factors were represented by long-term averages of empirical observations for Lake Balaton during 1973–1978.

Thus, the annual distribution of water temperature in degrees Celsius is given by

$$T(t) = 11 \cdot \left\{ 1 + \sin \left[\frac{2\pi}{365} (t - 16) - \frac{\pi}{2} \right] \right\} \quad (25)$$

where t is the current time in days, starting from January 1. Similarly, the annual development of incident solar radiation in $\text{cal cm}^{-2} \text{ day}^{-1}$ is given by

$$R(t) = 280 + 235 \cdot \sin \left[\frac{2\pi}{365} (t_w + 1) - \frac{\pi}{2} \right] \quad (26)$$

Equation (26) represents the weekly average value of incident solar radiation at various times of the year, with t_w as the number of the week, starting from the first week in January. Input–output flow rates for interbasin cross-sections, as well as precipitation rates for each basin, were taken to be exactly the same as those for 1977, which was considered to be a normal year with respect to water supply and water balance as a whole. The wind data for the phosphorus load-change simulations were also taken from the file for 1977.

The initial values of the phosphorus compartments for these simulations are presented in Table 21; they correspond to those evaluated earlier for January 1, 1977. The values of the model coefficients were not changed for the simulations and they remain as shown in Table 7.

All of the results obtained in the phosphorus load-change simulations have been expressed in terms of annual mean concentrations of the major phosphorus compartments, DIP, DOP, and F, and also in terms of the aggregated phosphorus fractions, POP and total phosphorus. These concentrations, and their standard deviations, are shown in Table 22. It is assumed that the phosphorus fractions mentioned are related most directly to the water quality issues of primary concern in Lake Balaton.

The results of the phosphorus load simulations are also presented separately for Basins I–IV. Annual mean phosphorus concentrations in Lake Balaton showed a significant response to load changes only in Basin I, and not in other parts of the lake. For example, a two-fold increase in phosphorus load resulted, for Basin I, in increases in annual mean concentrations of 87.6% (DIP), 45.9% (DOP), 30.7% (F), 26.4% (POP), and 44% (total phosphorus). For Basin II the annual mean phosphorus compartment concentrations increased by between 3% and 20% under the same two-fold load increase, while in Basins III and IV they remained practically unchanged in all the phosphorus load simulations.

Seasonal variations in the phosphorus concentrations in Basin I evaluated in the load-change simulations are presented in Table 23. These data make it possible to estimate minimum, maximum, and mean values for the main phosphorus compartments for each season and for any value of the reduction coefficient ϵ .

Tables 24–26 summarize the results of the simulations under varying phosphorus loads expressed in terms of simple correlations and R^2 values. Table 24 shows the relations found between annual phosphorus loads from controllable sources (for PD and total phosphorus separately) and phosphorus compartment concentrations averaged for annual and various seasonal periods. Table 25

TABLE 21 Initial values of phosphorus concentrations (mg P l^{-1}) used in the load-change simulations.

Phosphorus compartment	Symbol	Basin			
		I	II	III	IV
Dissolved inorganic phosphorus	DIP	0.01490	0.00730	0.00590	0.00340
Dissolved organic phosphorus	DOP	0.00450	0.00360	0.00290	0.00220
Phytoplankton phosphorus	F	0.00480	0.00360	0.00310	0.00240
Bacterial phosphorus	B	0.00070	0.00073	0.00070	0.00058
Inanimate particulate organic phosphorus	PD	0.02420	0.01820	0.01580	0.01350

TABLE 22 Annual mean phosphorus concentrations (μ) and standard deviations (σ) (both in $\mu\text{g P l}^{-1}$) evaluated by the model in the load-change simulations.

ϵ	Basin	DIP		DOP		F		POP		Total P	
		μ	σ	μ	σ	μ	σ	μ	σ	μ	σ
1.00	I	12.9	8.6	10.9	6.2	11.4	4.5	32.2	8.7	56.1	10.5
	II	4.3	3.0	6.7	3.9	6.4	2.6	20.7	6.2	31.7	7.9
	III	3.0	1.9	5.1	2.8	5.2	1.9	17.4	4.7	25.5	5.6
	IV	1.9	0.9	3.9	2.2	4.5	2.4	15.2	5.3	21.0	6.8
0.25	I	6.4	3.5	8.2	4.9	8.7	3.9	28.0	7.8	42.6	10.8
	II	4.3	2.8	6.8	3.8	6.5	2.8	22.1	6.2	33.2	8.3
	III	3.5	2.2	5.7	3.1	5.5	2.1	19.4	4.9	28.5	6.0
	IV	2.3	1.1	4.5	2.6	4.8	2.6	17.3	5.3	24.2	7.2
0.50	I	8.1	4.8	8.7	4.9	9.5	4.0	28.3	8.0	45.2	10.2
	II	4.1	2.7	6.5	3.6	6.3	2.7	20.8	6.2	31.4	7.9
	III	3.1	2.0	5.2	2.8	5.3	2.0	17.9	4.7	26.3	5.7
	IV	2.0	0.9	4.1	2.3	4.7	2.5	15.8	5.3	21.9	6.9
0.75	I	10.4	6.5	9.7	5.5	10.5	4.2	30.2	8.3	50.3	10.1
	II	4.2	2.8	6.6	3.7	6.3	2.6	20.6	6.2	31.4	7.9
	III	3.0	1.9	5.2	2.8	5.2	1.9	17.5	4.7	25.7	5.6
	IV	1.9	0.9	4.0	2.2	4.5	2.5	15.4	5.3	21.3	6.8
1.50	I	18.4	13.0	13.3	7.8	13.3	5.2	36.5	9.5	68.2	12.2
	II	4.7	3.4	7.2	4.3	6.6	2.6	20.9	6.3	32.8	8.2
	III	3.0	1.9	5.2	2.9	5.2	1.9	17.2	4.7	25.4	5.6
	IV	1.8	0.9	3.9	2.2	4.5	2.4	15.0	5.3	20.7	6.7
2.00	I	24.2	17.9	15.9	9.6	14.9	5.9	40.7	10.3	80.8	14.9
	II	5.2	3.9	7.7	4.8	6.8	2.7	21.3	6.5	34.2	8.6
	III	3.0	1.9	5.3	3.0	5.2	1.9	17.2	4.7	25.5	5.6
	IV	1.8	0.9	3.9	2.1	4.4	2.4	14.9	5.2	20.6	6.7

TABLE 23 Seasonal values of the phosphorus concentrations (mg P l⁻¹) in Basin I obtained in the load-change simulations.

ε	Form of phosphorus	Winter (January–March)						Spring (April–June)					
		Minimum		Mean	Maximum		Minimum		Mean	Maximum			
		Date	Value		Date	Value	Date	Value		Date	Value		
1.00	DIP	31.3	0.0146	0.0233	7.2	0.0272	17.5	0.0040	0.0065	1.4	0.0150		
	DOP	8.1	0.0042	0.0070	31.3	0.0136	1.6	0.0135	0.0182	16.5	0.0205		
	F	3.1	0.0046	0.0072	28.3	0.0123	17.4	0.0104	0.0136	30.6	0.0203		
	POP	7.2	0.0188	0.0268	30.3	0.0509	4.5	0.0243	0.0344	27.6	0.0520		
	TP	8.1	0.0445	0.0571	30.3	0.0796	4.5	0.0479	0.0592	28.6	0.0788		
0.25	DIP	31.3	0.0062	0.0109	1.1	0.0149	3.5	0.0021	0.0037	28.6	0.0064		
	DOP	15.1	0.0042	0.0056	31.3	0.0095	1.4	0.0095	0.0132	30.6	0.0171		
	F	6.1	0.0045	0.0054	31.3	0.0076	28.4	0.0070	0.0100	30.6	0.0166		
	POP	7.2	0.0165	0.0241	31.3	0.0457	4.5	0.0193	0.0291	27.6	0.0458		
	TP	7.2	0.0330	0.0407	31.3	0.0617	4.5	0.0347	0.0459	28.6	0.0675		
0.50	DIP	31.3	0.0083	0.0142	22.1	0.0164	17.5	0.0027	0.0044	1.4	0.0085		
	DOP	12.1	0.0042	0.0060	31.3	0.0106	1.4	0.0105	0.0141	30.6	0.0172		
	F	6.1	0.0045	0.0060	28.3	0.0090	17.4	0.0080	0.0110	30.6	0.0174		
	POP	7.2	0.0160	0.0237	31.3	0.0458	4.5	0.0201	0.0298	27.6	0.0464		
	TP	7.2	0.0369	0.0439	31.3	0.0649	4.5	0.0374	0.0483	28.6	0.0687		
0.75	DIP	31.3	0.0112	0.0185	5.2	0.0214	17.5	0.0033	0.0054	1.4	0.0115		
	DOP	8.1	0.0042	0.0065	31.3	0.0120	1.4	0.0120	0.0160	30.6	0.0186		
	F	6.1	0.0046	0.0066	28.3	0.0107	17.4	0.0092	0.0123	30.6	0.0188		
	POP	7.2	0.0172	0.0251	31.3	0.0481	4.5	0.0221	0.0320	27.6	0.0490		
	TP	8.1	0.0413	0.0501	31.3	0.0717	4.5	0.0424	0.0534	28.6	0.0733		
1.50	DIP	1.1	0.0149	0.0336	18.2	0.0401	17.5	0.0054	0.0089	1.4	0.0230		
	DOP	6.1	0.0042	0.0079	31.3	0.0165	1.4	0.0165	0.0230	17.5	0.0263		
	F	2.1	0.0046	0.0081	28.3	0.0158	28.4	0.0127	0.0162	30.6	0.0232		
	POP	7.2	0.0220	0.0304	30.3	0.0566	4.5	0.0288	0.0394	27.6	0.0581		
	TP	1.1	0.0491	0.0719	30.3	0.0967	4.5	0.0592	0.0713	28.6	0.0906		
2.00	DIP	1.1	0.0149	0.0447	18.2	0.0543	17.5	0.0068	0.0115	1.4	0.0324		
	DOP	6.1	0.0043	0.0086	31.3	0.0192	1.4	0.0192	0.0282	25.5	0.0326		
	F	2.1	0.0046	0.0090	28.3	0.0179	28.4	0.0149	0.0185	30.6	0.0259		
	POP	7.2	0.0251	0.0339	30.3	0.0623	18.5	0.0330	0.0443	27.6	0.0641		
	TP	1.1	0.0491	0.0873	30.3	0.1150	30.4	0.0707	0.0839	1.4	0.1067		

presents correlations between annual DIP load and mean phosphorus fractions, with DIP load subdivided into three groups: the first represents the DIP load from controllable sources according to the load-change simulations, the second shows the total DIP load from all controllable and uncontrollable sources considered in the model, while the third takes into account corrections to the total DIP load related to the amounts of DIP transferred from basin to basin by water- and wind-induced flows. Finally, Table 26 includes simple correlations between annual DIP, PD, and total phosphorus loads on the one hand, and the quantities of phosphorus transformed by the individual ecological processes considered in the model on the other.

TABLE 23 *Continued.*

ϵ	Form of phosphorus	Summer (July–September)					Autumn (October–December)				
		Minimum		Mean	Maximum		Minimum		Mean	Maximum	
		Date	Value		Date	Value	Date	Value		Date	Value
1.00	DIP	22.9	0.0045	0.0062	23.7	0.0090	1.10	0.0048	0.0159	31.12	0.0336
	DOP	30.9	0.0044	0.0134	2.7	0.0211	8.10	0.0038	0.0048	31.12	0.0056
	F	30.9	0.0116	0.0167	2.7	0.0207	12.12	0.0061	0.0082	1.10	0.0122
	POP	23.9	0.0307	0.0420	23.7	0.0532	31.10	0.0184	0.0256	27.11	0.0395
	TP	30.9	0.0404	0.0617	1.7	0.0797	31.10	0.0317	0.0464	4.12	0.0639
0.25	DIP	22.9	0.0027	0.0044	23.7	0.0069	1.10	0.0027	0.0068	31.12	0.0134
	DOP	30.9	0.0032	0.0111	2.7	0.0178	2.11	0.0022	0.0030	31.12	0.0037
	F	30.9	0.0087	0.0136	2.7	0.0171	12.12	0.0047	0.0058	1.10	0.0091
	POP	23.9	0.0257	0.0367	23.7	0.0477	31.10	0.0134	0.0219	27.11	0.0366
	TP	30.9	0.0322	0.0522	23.7	0.0691	31.10	0.0192	0.0317	27.11	0.0476
0.50	DIP	22.9	0.0032	0.0048	23.7	0.0074	1.10	0.0032	0.0092	31.12	0.0187
	DOP	30.9	0.0035	0.0113	2.7	0.0179	2.11	0.0028	0.0035	31.12	0.0043
	F	30.9	0.0096	0.0143	2.7	0.0179	12.12	0.0052	0.0066	1.10	0.0100
	POP	23.9	0.0267	0.0374	23.7	0.0482	31.10	0.0144	0.0223	27.11	0.0267
	TP	30.9	0.0341	0.0536	23.7	0.0701	31.10	0.0222	0.0350	4.12	0.0510
0.75	DIP	22.9	0.0038	0.0055	23.7	0.0081	1.10	0.0040	0.0124	31.12	0.0258
	DOP	30.9	0.0039	0.0123	2.7	0.0193	8.10	0.0033	0.0041	31.12	0.0049
	F	30.9	0.0106	0.0155	2.7	0.0192	12.12	0.0057	0.0074	1.10	0.0111
	POP	23.9	0.0286	0.0396	23.7	0.0505	31.10	0.0164	0.0239	27.11	0.0380
	TP	30.9	0.0371	0.0574	23.7	0.0743	31.10	0.0268	0.0404	4.12	0.0571
1.50	DIP	12.9	0.0059	0.0078	23.7	0.0107	1.10	0.0064	0.0234	31.12	0.0504
	DOP	30.9	0.0054	0.0160	2.7	0.0251	8.10	0.0048	0.0063	20.11	0.0071
	F	30.9	0.0135	0.0190	3.7	0.0235	28.12	0.0069	0.0097	1.10	0.0144
	POP	30.9	0.0348	0.0470	23.7	0.0587	31.12	0.0213	0.0292	27.11	0.0425
	TP	30.9	0.0472	0.0708	1.7	0.0913	31.10	0.0420	0.0589	31.12	0.0835
2.00	DIP	12.9	0.0073	0.0094	23.7	0.0125	1.10	0.0082	0.0314	31.12	0.0683
	DOP	30.9	0.0065	0.0188	2.7	0.0296	8.10	0.0058	0.0078	12.11	0.0090
	F	30.9	0.0154	0.0212	3.7	0.0262	28.12	0.0074	0.0109	1.10	0.0165
	POP	30.9	0.0386	0.0520	23.7	0.0643	31.12	0.0240	0.0326	8.10	0.0458
	TP	30.9	0.0540	0.0802	1.7	0.1035	1.11	0.0523	0.0719	31.12	0.1052

The R^2 values shown in Tables 24–26 indicate the fraction of the variation in phosphorus concentrations and phosphorus flows described by the regression relationship concerned. Taken together, the relationships summarized in Tables 24–26 may be used to evaluate the probable effects of changes in phosphorus load, resulting, for example, from water management strategies, on phosphorus concentrations or flows along individual transformation pathways or in any specific basin of the lake.

TABLE 24 Simple correlations between annual phosphorus loads^a and mean phosphorus concentrations^b in Lake Balaton.

Phosphorus fraction and season	Regression on annual PD load		Regression on annual TP load	
	$Y = a + bX$	R^2	$Y = a + bX$	R^2
<i>TP</i>				
Annual	$Y = 0.0201 + 0.0470X$	0.970	$Y = 0.0206 + 0.0267X$	0.988
Spring	$Y = 0.0230 + 0.0474X$	0.966	$Y = 0.0235 + 0.0268X$	0.982
Summer	$Y = 0.0283 + 0.0424X$	0.974	$Y = 0.0290 + 0.0239X$	0.977
Autumn	$Y = 0.0117 + 0.0457X$	0.960	$Y = 0.0121 + 0.0260X$	0.986
<i>DIP</i>				
Annual	$Y = 0.0176X$	0.926	$Y = 0.0101X$	0.965
Spring	$Y = 0.0002 + 0.0083X$	0.952	$Y = 0.0003 + 0.0048X$	0.983
Summer	$Y = 0.0013 + 0.0064X$	0.975	$Y = 0.0013 + 0.0036X$	0.993
Autumn	$Y = -0.0013 + 0.0234X$	0.912	$Y = -0.0013 + 0.0135X$	0.955
<i>DOP</i>				
Annual	$Y = 0.0040 + 0.0090X$	0.955	$Y = 0.0041 + 0.0051X$	0.976
Spring	$Y = 0.0057 + 0.0166X$	0.899	$Y = 0.0058 + 0.0095X$	0.939
Summer	$Y = 0.0048 + 0.0112X$	0.983	$Y = 0.0050 + 0.0063X$	0.987
Autumn	$Y = 0.0010 + 0.0050X$	0.936	$Y = 0.0010 + 0.0029X$	0.971
<i>POP</i>				
Annual	$Y = 0.0162 + 0.0204X$	0.962	$Y = 0.0166 + 0.0115X$	0.962
Spring	$Y = 0.0167 + 0.0225X$	0.968	$Y = 0.0170 + 0.0127X$	0.972
Summer	$Y = 0.0222 + 0.0248X$	0.965	$Y = 0.0226 + 0.0139X$	0.964
Autumn	$Y = 0.0121 + 0.0170X$	0.966	$Y = 0.0124 + 0.0096X$	0.966
<i>F</i>				
Annual	$Y = 0.0045 + 0.0085X$	0.958	$Y = 0.0046 + 0.0048X$	0.974
Spring	$Y = 0.0047 + 0.0111X$	0.961	$Y = 0.0048 + 0.0063X$	0.980
Summer	$Y = 0.0074 + 0.0115X$	0.963	$Y = 0.0075 + 0.0065X$	0.970
Autumn	$Y = 0.0028 + 0.0066X$	0.945	$Y = 0.0028 + 0.0038X$	0.967

^aPhosphorus loads X are expressed in $\text{mg P l}^{-1} \text{ year}^{-1}$.

^bSeasonal mean phosphorus concentrations Y are expressed in mg P l^{-1} .

8. CONCLUSIONS

This report has presented results obtained using the Balaton Sector Model (BALSECT). The model describes the biochemical interaction between the five phosphorus compartments (dissolved inorganic-P, dissolved organic-P, inanimate particulate organic-P, phytoplankton-P, and bacterial-P) of major importance in the Lake Balaton ecosystem, and takes into account phosphorus exchange through the sediment-water interface as well as the horizontal interbasin transport of the phosphorus compartments by advective and wind-induced water flows. The model was applied to a set of original field observations of water temperature, wind, solar radiation, and water balance, together with an improved representation of external phosphorus loading, in order to investigate the dynamics of the five phosphorus compartments in the four basins of Lake Balaton during the period 1976-1979.

The behavior of the main phosphorus compartments considered in the model, together with field observations for 1976-1979, was illustrated with a series of

TABLE 25 Simple correlations between annual DIP loads^a and mean phosphorus concentrations.^b

Annual DIP load X from	Form of phosphorus	Regressions for seasonal mean concentrations Y ($Y = a + bX$)							
		Annual		Spring		Summer		Autumn	
		$a + bX$	R^2	$a + bX$	R^2	$a + bX$	R^2	$a + bX$	R^2
Controllable sources	POP =	0.0189 + 0.0276X	0.884	0.0195 + 0.0307X	0.905	0.0255 + 0.0334X	0.882	0.0144 + 0.0230X	0.883
	DOP =	0.0050 + 0.0127X	0.958	0.0073 + 0.0242X	0.967	0.0062 + 0.0153X	0.922	0.0015 + 0.0074X	0.986
	DIP =	0.0015 + 0.0257X	0.996	0.0011 + 0.0120X	0.992	0.0020 + 0.0089X	0.959	0.0008 + 0.0345X	0.997
	F =	0.0056 + 0.0118X	0.926	0.0060 + 0.0155X	0.942	0.0087 + 0.0158X	0.894	0.0035 + 0.0093X	0.932
	TP =	0.0255 + 0.0659X	0.961	0.0284 + 0.0662X	0.951	0.0338 + 0.0577X	0.906	0.0159 + 0.0660X	0.979
All sources, including both controllable and uncontrollable	POP =	0.0173 + 0.0255X	0.937	0.0177 + 0.0283X	0.951	0.0235 + 0.0309X	0.937	0.0130 + 0.0212X	0.940
	DOP =	0.0044 + 0.0116X	0.976	0.0061 + 0.0217X	0.965	0.0054 + 0.0140X	0.965	0.0011 + 0.0066X	0.989
	DIP =	0.0004 + 0.0230X	0.988	0.0005 + 0.0108X	0.997	0.0015 + 0.0081X	0.988	0.0308X	0.983
	F =	0.0044 + 0.0146X	0.976	0.0045 + 0.0192X	0.984	0.0073 + 0.0196X	0.961	0.0026 + 0.0115X	0.975
	TP =	0.0220 + 0.0600X	0.985	0.0249 + 0.0602X	0.977	0.0304 + 0.0532X	0.955	0.0133 + 0.0588X	0.993
All sources, with correction for DIP transport by water- and wind-induced flows	POP =	0.0161 + 0.0350X	0.947	0.0166 + 0.0375X	0.954	0.0221 + 0.0420X	0.947	0.0120 + 0.0288X	0.949
	DOP =	0.0039 + 0.0156X	0.983	0.0051 + 0.0294X	0.972	0.0047 + 0.0190X	0.971	0.0008 + 0.0090X	0.991
	DIP =	0.0006 + 0.0310X	0.987	0.0146X	0.997	0.0012 + 0.0110X	0.991	-0.0021 + 0.0414X	0.979
	F =	0.0049 + 0.0108X	0.984	0.0052 + 0.0142X	0.977	0.0079 + 0.0145X	0.953	0.0030 + 0.0085X	0.969
	TP =	0.0193 + 0.0811X	0.990	0.0222 + 0.0816X	0.984	0.0280 + 0.0720X	0.963	0.0107 + 0.0794X	0.995

^aDIP loads X are expressed in mg P l⁻¹ year⁻¹.

^bSeasonal mean phosphorus concentrations Y are expressed in mg P l⁻¹.

TABLE 26 Simple correlations between phosphorus transformation by individual processes (Y) and annual phosphorus loads (DIP_L , PD_L , and TP_L).^a

Process modeled	Regression on DIP_L		Regression on PD_L		Regression on TP_L	
	$Y = a + bDIP_L$	R^2	$Y = a + bPD_L$	R^2	$Y = a + bTP_L$	R^2
Phytoplankton DIP uptake	$Y = 0.1366 + 0.8418DIP_L$	0.994	$Y = 0.1126 + 0.6555PD_L$	0.965	$Y = 0.1186 + 0.3731TP_L$	0.989
Bacterial DOP uptake	$Y = 0.1729 + 0.2506DIP_L$	0.949	$Y = 0.1630 + 0.2001PD_L$	0.968	$Y = 0.1660 + 0.1126TP_L$	0.971
Bacterial DIP excretion	$Y = 0.0933 + 0.1430DIP_L$	0.947	$Y = 0.0876 + 0.1142PD_L$	0.967	$Y = 0.0894 + 0.0643TP_L$	0.970
Detritus decomposition to DOP	$Y = 0.0586 + 0.2088DIP_L$	0.941	$Y = 0.0559 + 0.1569PD_L$	0.850	$Y = 0.0559 + 0.0907TP_L$	0.901
Phytoplankton DOP excretion	$Y = 0.0333 + 0.2178DIP_L$	0.994	$Y = 0.0271 + 0.1695PD_L$	0.982	$Y = 0.0287 + 0.0965TP_L$	0.990
Phytoplankton contribution to detritus	$Y = 0.1158 + 0.5444DIP_L$	0.986	$Y = 0.1750 + 0.3361PD_L$	0.684	$Y = 0.1034 + 0.2422TP_L$	0.989
Bacterial contribution to detritus	$Y = 0.0796 + 0.0844DIP_L$	0.941	$Y = 0.0763 + 0.0673PD_L$	0.957	$Y = 0.0773 + 0.0379TP_L$	0.961
Net detritus sedimentation	$Y = 0.1030 + 1.6200DIP_L$	0.965	$Y = 0.0904 + 1.2307PD_L$	0.995	$Y = 0.0915 + 0.7080TP_L$	0.994

^aQuantities transformed in each of the processes modeled, as well as the phosphorus loads, are expressed in $mg\ P\ l^{-1}\ year^{-1}$.

dynamic curves. Model results for each of the phosphorus compartments were presented as monthly, seasonal, and annual mean values; the standard deviations of these means were also calculated to assess the dynamic properties of each phosphorus fraction within the Lake Balaton ecosystem. This data set has considerable value in comparing the different ecological models developed for studying the eutrophication of Lake Balaton resulting from the input of phosphorus to the water body from the area of the Balaton watershed.

The adequacy of the model in representing phosphorus compartment dynamics within the period studied was evaluated using three statistical tests. The first test compared the variances between modeling results and observations on combined sets of data for all phosphorus fractions. The ratio of variances between simulated and observed phosphorus data was estimated to vary in the range 48.5–122.2% (mean 51.5%) for the period 1976–1979. In the second test, the quantitative relationship between phosphorus compartment levels in the observed and simulated time series was studied by regression analysis, both simple and weighted. Here, model adequacy was assessed in terms of statistical criteria such as the mean, standard deviation, regression equation coefficients a and b , and R^2 and t -statistics. On the basis of these statistics it was shown that the model describes reasonably well the ranges of fluctuation of all the phosphorus compartments as well as the basic trends underlying temporary changes in phosphorus concentration in the individual basins of Lake Balaton during the study period. In the third statistical test, Theil's inequality coefficient was calculated for each phosphorus compartment on the basis of field observations and simulation results. This coefficient shows that the ranges of error in modeling the dynamics of each phosphorus compartment were 0.187–0.294 (mean 0.255) for total-P, 0.244–0.361 (0.309) for particulate organic-P, 0.272–0.353 (0.299) for total dissolved P, 0.299–0.402 (0.362) for DIP, and 0.332–0.429 (0.381) for DOP. The ranges of error in simulating the phosphorus dynamics in different parts of the lake were 0.198–0.292 (mean 0.259) for Basin I, 0.241–0.33 (0.273) for Basin II, 0.232–0.4 (0.319) for Basin III, and 0.291–0.36 (0.351) for Basin IV. The overall errors in modeling the phosphorus compartment dynamics were evaluated as 0.276, 0.277, 0.219, and 0.307 for 1976–1979, respectively, and as 0.279 for the entire four-year period.

To analyze the simulation results from the point of view of explaining phosphorus dynamics, special calculations of phosphorus flows were performed for all phosphorus-dependent activities and sources. This made it possible to obtain time distributions and quantitative information on phosphorus load for the comparative analysis of the phosphorus contributions from each of the external sources considered in the model.

The role of sediments as a source of phosphorus was also evaluated in some detail. Based on the simulation results it was concluded that sediments are of major importance in the Lake Balaton phosphorus cycle and specifically in the process of eutrophication. Overall there was a continual and marked tendency for phosphorus to accumulate in the sediments in all seasons during the period studied, 1976–1979. Net particulate-P losses to the sediments as a result of the imbalance between resuspension and sedimentation were estimated to be higher in the spring and summer months, when the rates of the ecological phosphorus transformation processes are highest and the total amount of particulate-P formed biochemically is most significant. The amount of DIP released from the sediment is

considered as significant only during the spring and summer months, but even this process only partially compensates for the total phosphorus losses caused by sedimentation.

The process of phosphorus cycling in Lake Balaton was further investigated by considering external input-output ($EF_i - OF_i$), system (SPF), compartment (CF_i), and total (CF_{TP}) phosphorus fluxes for each basin of the lake. In this analysis the ratio CF_i/EF_i was used to measure the importance of internal phosphorus transformation in providing phosphorus as opposed to external loading. The ratio for DIP was quite stable (1.3–1.5) during 1976–1979 in Basin I, where the role of external loading (primarily from the Zala river) is significantly higher than in Basins II–IV; for the latter basins the ratio CF_{DIP}/EF_{DIP} was 2.7–3.9 for 1976 and 1979 and 2.0–2.4 for 1977 and 1978. For DOP, internal phosphorus cycling was considered much more important than external loading and the ratio CF_{DOP}/EF_{DOP} was estimated as lying in the range 15.2–48.7 for all basins and all four years. For inanimate particulate organic-P the corresponding ratio appears to have been almost constant at 1.2–1.3 for all basins in 1976–1979, which testifies to a definite and stable balance between all the processes providing external and internal input of particulate-P. The ratio CF_{TP}/SPF , showing the relative importance of biochemical cycling as opposed to loading by external inputs and hydrodynamic transport, was estimated to lie in the ranges 1.6–1.9 for 1976 and 1977, 1.5–1.6 for 1978, and 1.8–2.2 for 1979. The role of hydrodynamic transport in phosphorus loading was approximated by the ratio SPF/EF_{TP} , which varied relatively little at 1.07–1.14 for Basins I–III and 1.03–1.04 for Basin IV throughout the study period.

The main features of the lake ecosystem as well as the roles of individual compartments in the phosphorus cycle were analyzed by considering the simulated phosphorus dynamics and fluxes. Flux rates, pool sizes, and turnover times were computed for individual phosphorus compartments. The turnover time was useful here in interpreting the processes of phosphorus transformation and the cycling of individual phosphorus compartments. Overall, the turnover time reflects the complex relationship existing between environmental conditions (or factors), nutrient loading, and the limnetic properties of the water body considered. Turnover times were averaged on a daily, monthly, and annual basis. It was shown that the temporary patterns of daily mean turnover-time dynamics are specific to definite biological and chemical compartments. Phosphorus pools appear to turn over fastest in the biological compartments, bacteria and phytoplankton, and in the inanimate particulate organic-P that is directly dependent on microorganism activity.

The turnover time values show that all phosphorus fractions are much more mobile in Basin I than in the other basins as a result of the higher watershed nutrient loading and higher phosphorus concentrations in the water there, as well as the higher level of phytoplankton activity in the water of Basin I. Fluctuations of turnover time within individual seasons, as well as the seasonal differences in this parameter for phytoplankton-P, DIP, and DOP, all increase from Basin I to Basin IV as a result of the different, combined effects of all the factors influencing phosphorus transformation and the turnover of individual compartments in the different areas of the lake. During the summer months the daily variations in turnover time are much less pronounced than in other seasons. From year to year some seasonal differences in the phosphorus cycle may be seen on examining the monthly mean turnover times for individual compartments in Basins I–IV. These

differences are a consequence of changes in environmental conditions and external phosphorus loading within the period 1976–1979. However, the annual mean turnover times indicate that approximately similar conditions influencing the phosphorus cycle persisted throughout the study period.

The response of the lake to changes in phosphorus load was estimated in model runs using environmental data, including information on water temperature, solar radiation, and water balance, averaged for several years. The expected in-lake concentration of each of the major phosphorus compartments was computed on the basis of various possible phosphorus loads from a controllable source, namely the Zala river. These data were then generalized as simple correlation equations describing the seasonal and annual phosphorus levels as functions of phosphorus loadings. Phosphorus flows along the individual transformation pathways considered in this model were also evaluated as simple functions of the input loads from the Zala river.

In conclusion, we feel that IIASA's Balaton Case Study has provided some valuable insight into the behavior of the Lake Balaton ecosystem, and that this will prove useful in the development of future policies for the management and control of phosphorus levels and eutrophication within the lake.

REFERENCES

- Allard, R.J. (1977) *An Approach to Econometrics*. Philip Allan, London.
- Beck, M.B. (1978) *A Comparative Case Study of Dynamic Models for DO-BOD-Algae Interaction in a Freshwater River*. Research Report RR-78-19. International Institute for Applied Systems Analysis, Laxenburg, Austria.
- Gächter, R. (1968) Phosphorhaushalt und planktonische Primärproduktion im Vierwaldstättersee (Horder Bucht). *Schweizerische Zeitschrift für Hydrologie*, 30(1):1–66.
- Jolankai, G. and Somlyódy, L. (1981) *Nutrient Loading Estimate for Lake Balaton*. Collaborative Paper CP-81-21. International Institute for Applied Systems Analysis, Laxenburg, Austria.
- Kindler, J. (1981) Toward integrated policies for water-resources management. *IIASA Reports*, 3(1):117–133.
- Leonov, A.V. (1980) *Mathematical Modeling of Phosphorus Transformation in the Lake Balaton Ecosystem*. Working Paper WP-80-149. International Institute for Applied Systems Analysis, Laxenburg, Austria.
- Leonov, A.V. (1981a) *Applying the Balaton Sector Model for Analysis of Phosphorus Dynamics in Lake Balaton, 1976–1978*. Working Paper WP-81-118. International Institute for Applied Systems Analysis, Laxenburg, Austria.
- Leonov, A.V. (1981b) *A Review of Mathematical Models of Phosphorus Release from Sediments*. Working Paper WP-81-153. International Institute for Applied Systems Analysis, Laxenburg, Austria.
- Leonov, A.V. (1982) *Transformation and Turnover of Phosphorus Compounds in the Lake Balaton Ecosystem, 1976–1978*. Working Paper WP-82-27. International Institute for Applied Systems Analysis, Laxenburg, Austria.
- Patten, B.C. *et al.* (1975) Total ecosystem model for a core in Lake Texoma. In B.C. Patten (Ed.), *System Analysis and Simulation in Ecology*, vol. 3. Academic Press, New York.
- Pomeroy, L.R. (1970) The strategy of mineral cycling. *Annual Review of Ecology and Systems*, 1:171–190.
- Theil, H. (1971) *Applied Economic Forecasting*. North-Holland, Amsterdam.

- van Straten, G., Jolankai, G., and Herodek, S. (1979) *Review and Evaluation of Research on the Eutrophication of Lake Balaton – A Background Report for Modeling*. Collaborative Paper CP-79-13. International Institute for Applied Systems Analysis, Laxenburg, Austria.
- van Straten, G. and Somlyódy, L. (1980) *Lake Balaton Eutrophication Study: Present Status and Future Program*. Working Paper WP-80-187. International Institute for Applied Systems Analysis, Laxenburg, Austria.
- Watson, V. and Loucks, O. (1979) An analysis of turnover time in a lake ecosystem and some implications for system properties. In E. Halfon (Ed.), *Theoretical System Ecology*, pp. 355–383. Academic Press, New York.

APPENDIX: BALSECT Nomenclature

Model Variables

A_j	Cross-sectional area between basins j and $j + 1$ (m^2)
$C_{i,j}$	Concentration of phosphorus compartment i in basin j ($mg\ P\ l^{-1}$)
d_j	Average depth of basin j (m)
$DIP_{r,j}$	Variable time-average flux of DIP from sediments in basin j ($mg\ P\ l^{-1}\ day^{-1}$)
DIP_Z	Zala river DIP load ($mg\ P\ l^{-1}\ day^{-1}$)
C_{DIP}^r	Concentration of DIP in rainwater ($mg\ P\ l^{-1}$)
C_{DOP}^r	Concentration of DOP in rainwater ($mg\ P\ l^{-1}$)
C_{PD}^r	Concentration of PD in rainwater ($mg\ P\ l^{-1}$)
CZ_{DIP}	Sewage DIP load ($mg\ P\ l^{-1}\ day^{-1}$)
f	Daily period of sunlight (hours)
i	Phosphorus compartment, equal to 1 (PD), 2 (DOP), 3 (B), 4 (DIP), or 5 (F)
I	Current light intensity ($cal\ cm^{-2}\ day^{-1}$)
I_{av}	Daily mean light intensity ($cal\ cm^{-2}\ day^{-1}$)
I_{max}	Maximum light intensity ($cal\ cm^{-2}\ day^{-1}$)
I_{opt}	Optimal light intensity ($cal\ cm^{-2}\ day^{-1}$)
j	Basin of Lake Balaton, $j = 1, 2, 3, 4$
K_e	Light extinction coefficient (m^{-1})
$L_{B,j}$	Specific rate of metabolic excretion by bacteria in basin j (day^{-1})
$L_{F,j}$	Specific rate of metabolic excretion by phytoplankton in basin j (day^{-1})
$LOAD_{i,j}$	Net rate of phosphorus loading in compartment i and basin j ($mg\ P\ l^{-1}\ day^{-1}$)
$M_{B,j}$	Specific rate of nonpredatorial mortality of bacteria in basin j (day^{-1})
$M_{F,j}$	Specific rate of nonpredatorial mortality of phytoplankton in basin j (day^{-1})

PD_{r_j}	Time-average flux of PD from sediments in basin j ($\text{mg P l}^{-1} \text{ day}^{-1}$)
PD_Z	Zala river PD load ($\text{mg P l}^{-1} \text{ day}^{-1}$)
Q_{in_j}	Input flow rate for basin j ($\text{m}^3 \text{ day}^{-1}$)
Q_{out_j}	Output flow rate for basin j ($\text{m}^3 \text{ day}^{-1}$)
Q_{pr_j}	Precipitation rate for basin j ($\text{m}^3 \text{ day}^{-1}$)
$Q_{win_j}^a$	Input rate of wind-induced flow through left interbasin cross-sectional area for basin j
$Q_{win_j}^b$	Input rate of wind-induced flow through right interbasin cross-sectional area for basin j
$Q_{wout_j}^a$	Output rate of wind-induced flow through left interbasin cross-sectional area for basin j
$Q_{wout_j}^b$	Output rate of wind-induced flow through right interbasin cross-sectional area for basin j
τ_{B_j}	Excretion activity of bacteria in basin j (dimensionless)
τ_{F_j}	Excretion activity of phytoplankton in basin j (dimensionless)
$R_{i,j}$	Net rate of biochemical phosphorus transformation in compartment i and basin j
R_{IF}	Light reduction factor for phytoplankton uptake rate (dimensionless)
R_{TB}	Temperature reduction factor for bacterial uptake rate (dimensionless)
R_{TF}	Temperature reduction factor for phytoplankton uptake rate (dimensionless)
S_j	Rate of detritus sedimentation in basin j ($\text{mg P l}^{-1} \text{ day}^{-1}$)
τ	Wind direction
t_n	Time of day (hours)
t_p	Time of maximum light intensity ($t_n = 12$)
T	Water temperature (degrees Celsius)
TP_Z	Zala river total phosphorus load ($\text{mg P l}^{-1} \text{ day}^{-1}$)
$TR_{i,j}$	Net rate of horizontal phosphorus transport for compartment i in basin j ($\text{mg P l}^{-1} \text{ day}^{-1}$)
UP_{B_j}	Specific rate of nutrient uptake by bacteria in basin j (day^{-1})
UP_{F_j}	Specific rate of nutrient uptake by phytoplankton in basin j (day^{-1})
V_j	Volume of basin j (m^3)
W	Wind speed (m s^{-1})

Model Coefficients $\alpha_i, k, v_i, y_i, K_i, U, \alpha, \beta, \gamma_i, \varepsilon.$

THE AUTHOR

Alexander Leonov joined IIASA in September 1977 from the State Institute of Oceanography in Moscow. From then until December 1981 he carried out research into the construction of mathematical models within the Resources and Environment Area. At the end of 1981 he returned to the Soviet Union to take up an appointment at the Institute of Water Problems of the USSR Academy of Sciences in Moscow.

Dr. Leonov received his Candidate of Chemical Science degree (1975) from the Hydrochemical Institute in Novochoerkassk. His research interests include the modeling of biochemical oxygen demand (BOD), the transformation of chemical organic and inorganic compounds, the dynamics of microorganisms in natural waters, and the kinetic description of BOD in natural water bodies and sewage with special reference to the control of water quality.

