



Model of European Natural Gas Production, Trade, and Consumption

Nakicenovic, N. and Strubegger, M.

IIASA Working Paper

WP-84-053

September 1984



Nakicenovic, N. and Strubegger, M. (1984) Model of European Natural Gas Production, Trade, and Consumption. IIASA Working Paper. WP-84-053 Copyright © 1984 by the author(s). <http://pure.iiasa.ac.at/2465/>

Working Papers on work of the International Institute for Applied Systems Analysis receive only limited review. Views or opinions expressed herein do not necessarily represent those of the Institute, its National Member Organizations, or other organizations supporting the work. All rights reserved. Permission to make digital or hard copies of all or part of this work for personal or classroom use is granted without fee provided that copies are not made or distributed for profit or commercial advantage. All copies must bear this notice and the full citation on the first page. For other purposes, to republish, to post on servers or to redistribute to lists, permission must be sought by contacting repository@iiasa.ac.at

NOT FOR QUOTATION
WITHOUT PERMISSION
OF THE AUTHOR

**MODEL OF EUROPEAN NATURAL GAS
PRODUCTION, TRADE, AND CONSUMPTION**

N. Nakicenovic
M. Strubegger

September 1984
WP-84-53

Working Papers are interim reports on work of the International Institute for Applied Systems Analysis and have received only limited review. Views or opinions expressed herein do not necessarily represent those of the Institute or of its National Member Organizations.

INTERNATIONAL INSTITUTE FOR APPLIED SYSTEMS ANALYSIS
2361 Laxenburg, Austria

PREFACE

This working paper represents the first in the series to be published as a description of ongoing activities in the IIASA International Gas Study. Thus, the paper represents a report of one particular task that is nearing completion. The working papers will be presented as individual research activities, although they form only one part of the overall study.

This particular paper describes one approach of addressing natural gas production, trade, and use in Europe. For this purpose Europe was divided into five regions in order to distinguish between different endowments with natural gas resources, energy requirements, levels of economic development, and economic infrastructures.

The basic objective of the approach was to develop a simple model that can describe future natural gas production, trade, and use on an interactive basis with the analyst. Thus, the model represents a flexible tool that helps identify important issues and questions that could be addressed by other activities within the International Gas Study.

H-H. Rogner
Leader
International Gas Study

CONTENTS

INTRODUCTION	1
CURRENT NATURAL GAS USE IN EUROPE	2
REPRESENTATION OF END USE	9
REPRESENTATION OF NATURAL GAS TRADE	9
THE ENVISAGED STRUCTURE OF THE ENERGY SYSTEM	11
THE MULTI-OBJECTIVE APPROACH	14
CONCLUSION	17

MODEL OF EUROPEAN NATURAL GAS PRODUCTION, TRADE, AND CONSUMPTION

N. Nakicenovic and M. Strubegger

INTRODUCTION

Natural gas is a promising future source of energy in Europe. Unlike other fossil energy forms, natural gas produces limited particulate and sulfur emissions and even these could be reduced substantially by use of relatively simple measures. Unfortunately, natural gas is not as easy to transport over long distances and distribute to the final user as crude oil and its products due to its gaseous form at ambient temperatures. Natural gas use is therefore invariably associated with the need for elaborate infrastructures for long distance transport, storage, and distribution for various uses. In addition, in its gaseous form natural gas cannot be stored in compact reservoirs so that its use is limited to stationary devices with a direct connection with the distribution grid. Similar limitations are also present on the supply side of the energy system. Natural gas is transported by two technologies—pipelines, usually for continental links, and LNG, usually for intercontinental links. Natural gas pipelines and LNG vessels and facilities are capital-intensive and, once installed, they represent a commitment for the lifetime of the facilities on the order of 15 to 20 years.

These potential opportunities and limitations in the widespread use of natural gas in Europe point to the need for prudent planning on the side of both the consumer and the supplier. Investments in inappropriate systems could not only be devastating for the utilities and natural gas suppliers, but they could also have a major impact on general energy availability and use in Europe. In order to understand the requirements that will be imposed on future natural gas use and supply and on the whole energy system in Europe, it is necessary to investigate not only one but a number of different futures that look plausible given the past and current developments. It is proposed here to invent such plausible futures in form of scenarios because *the* actual future is not known. Scenarios offer an attractive alternative to attempts to predict the unknown future, since they permit the comparison of different assumptions about the structure and form of the future energy system in Europe. In fact, it is probably advisable to investigate a whole range of extreme and even conflicting future developments in order to analyze many of the critical characteristics of possible future energy systems and the role of natural gas. In other words, it is suggested that a number of different scenarios should be developed and that the comparisons of various strategies should be evaluated within and among them.

In order to facilitate the scenario writing and actual quantitative evaluations, a system of models have been designed representing what are, in the view of the authors, the most crucial features of the European energy system relevant for natural gas supply and use. Europe was divided into five regions in

order to distinguish between different endowments with natural gas resources, energy requirements, levels of economic development, and economic systems. The regional division of Europe consists of North, Central, South, and East Europe and also encompasses the USSR as the fifth region. For these regions a model of the energy system was developed which includes all important phases of natural gas extraction, trade, transport, conversion, distribution, and end use and that also includes other competing fuels and facilities. The models of North, Central, South and East Europe are completed and the work on the USSR model is in progress.

Together these models comprise the skeleton of this basic approach. They provide an easy-to-use tool for guaranteeing consistency of assumptions and changes foreseen by the analyst for the future. Thus, it is possible to introduce modifications of both the structure of the envisaged energy system and the specifications of energy availability and demand, or the specifications of various technologies and processes. Because complex systems such as the European energy system do not operate under a single goal or objective, the possibility to optimize the future structure of the system under different and perhaps even conflicting objectives has been incorporated in this approach. Thus, this model set offers an interactive tool for investigating many possible strategies for natural gas supply and use.

The model was primarily developed in order to provide a deeper understanding of the opportunities of wider substitution of other fuels by natural gas in end use and electricity generation, while at the same time permitting analysis of changing patterns in natural gas trade and extraction. Because the specification of multiple objectives are allowed to be imposed on the structure of the system in addition to constraints and strict bounds, it is possible to address such seemingly different questions simultaneously. Thus, a typical strategy of an exporting region may be to maximize revenues, while at the same time it could be also preferred to minimize the actual volume of exports. Consuming regions may, on the other hand, wish to maximize the energy use in certain sectors of the economy while they may at the same time desire to avoid the adverse effects of increased energy consumption such as sulfur emissions. They could also be interested in avoiding excessive expenditures by minimizing the cost of energy supply and use, and so on. Many such different objectives could easily be generated. This approach offers a tool that transforms such objectives into criteria for determining consistent energy system structure and energy flows within and among the five regions of Europe and major natural gas exporting areas.

CURRENT NATURAL GAS USE IN EUROPE

Historically speaking natural gas has achieved some of the fastest growth rates of any primary energy form in Europe. This rapid introduction of natural gas as an important source of energy is in part due to its premium qualities as a fuel and still relatively low prices compared with crude oil. It was, however, also due to the gas distribution infrastructure already available in many metropolitan areas of Europe "left over" from the days of city gas manufacture from coal and heavy oil products. Thus, at the beginning of its widespread market introduction, natural gas benefited from existing distribution infrastructure so that its initial penetration rates were indeed very impressive, ranging up to two-digit growth rates over an extended number of years in many cases. This phase of natural gas expansion within the energy system is now almost com-

pleted in Europe, so that additional growth in its use can only be achieved by addition and expansion of existing supply and distribution systems.

Table 1 shows that in 1980 natural gas contributed almost 15 percent to primary energy use in Europe. The natural gas share was highest in Central Europe, reaching almost 18 percent. Considering that natural gas reached only a two percent share in total primary energy twenty years earlier (i.e., 1960), the market penetration rate was indeed rapid during this early introduction phase.

Table 1. Primary Energy Consumption, 1980 (GWyr/yr).

Europe	Solids	Crude Oil	Natural Gas	Nuclear ^a	Hydro ^a	Elec- ^a tricity-	Total
North	21.0	64.7	2.4	11.4	40.9	0.2	140.6
Central	311.1	593.7	216.0	57.8	53.3	-0.6	1231.3
South	65.2	251.2	39.4	2.4	33.6	0.9	392.7
East	323.5	144.1	89.2	7.8	9.1	5.4	579.1
Total	720.8	1053.7	347.0	79.4	136.9	5.9	2343.7

^aGiven as primary energy equivalent.

This extensive use of natural gas as an important source of energy is possible in most of the European countries primarily through exploitation of Western European resources in the North Sea and the Netherlands, and through imports from overseas. The Soviet Union is the most important exporter of natural gas to the four natural gas importing regions of Europe, and if most of the current plans materialize it will maintain this role at least during the next decades. A much less important overseas source of natural gas in Europe is North Africa. Most of the Algerian and Libyan natural gas is supplied in liquefied form (LNG) by sea routes in LNG tankers, but there is also a direct pipeline from North Africa to Italy in operation.

Table 2 illustrates how much natural gas was imported by the four European regions in 1980 from the USSR, the North Sea, Central Europe (Netherlands) and North Africa. In 1980, Finland imported about 1.2 GWyr/yr* of natural gas from the Soviet Union by a pipeline and the other two North European countries, Norway and Sweden, consumed only small amounts of domestically produced gas. It should be observed that, although Norway exploits some of the richest natural gas sites in the North Sea, most of this gas is piped to Central Europe (i.e., to the UK and to the European gas grid). In the regional partition of Europe, it was assumed that the Norwegian North Sea is an external source of natural gas for North Europe and other regions. This, however, is an abstraction in the model that helps simplify the treatment of regional gas trade and was not intended to represent anything but a model-specific measure.

An additional pipeline is due to become operational during 1985 from Denmark to Sweden with a capacity of about 0.5 GW. Currently, the Finnish pipeline from the Soviet Union is used only at about one half capacity, so that total

*One GWyr/yr of natural gas corresponds to about 850 million cubic meters or about 30 billion cubic feet.

Table 2. Natural Gas Imports, 1980 (GWyr/yr).

Europe	North Sea	Central Europe	USSR	North Africa	Total
North			1.2		1.2
Central	32.3	53	22.2	2.3	109.8
South		7	10.4	3.8	21.2
East			33.3		33.3
Total	32.3	60	67.1	6.1	165.5

natural gas imports by North Europe could amount to almost 3 GWyr/yr by the end of 1985 without the need for additional transport infrastructure.

The largest source of natural gas imported to Central Europe is the North Sea (i.e., the Norwegian part of the North Sea, since the UK production is used domestically) with a total volume of more than 32 GWyr/yr in 1980. The Netherlands exported even more natural gas in 1980, amounting to almost 60 GWyr/yr, but most of these exports (53 GWyr/yr) went to other Central European countries (Belgium, France, FRG, Luxembourg, and Switzerland). Only about 7 GWyr/yr of Dutch natural gas exports to Italy are treated as effective exports to South Europe.

The Soviet Union exported about 22 GWyr/yr of natural gas to Central Europe in 1980 and another 10 GWyr/yr to South Europe (Italy and Yugoslavia). Most of these exports were transported via a pipeline across the border between Czechoslovakia and Austria. These exports could be expanded substantially in the near future, because the new Soviet pipeline, with a maximal capacity of about 40 GW, is completed, and another four pipelines could be built before the turn of the century, which could bring the total export capacity of the Soviet Union to more than 120 GW.

East Europe imports natural gas exclusively from the Soviet Union and, at a level of about 33 GWyr/yr, accounts for more than one half of all Soviet natural gas exports. This is even slightly higher than the Central European imports from the North Sea and constitutes the highest natural gas trade between any two regions of Europe.

Natural gas imports from North Africa (today mainly from Libya and Algeria) amount to less than 4 GWyr/yr to South Europe (Spain and Italy) and to less than 2.5 GWyr/yr to Central Europe (UK and France in LNG form). Thus, North Africa represents only a marginal source of natural gas when compared with other exporting regions such as the North Sea and the USSR. In the future scenarios, North African natural gas exports would include other potential natural gas imports to Western Europe. For example, LNG imports from the Pacific Basin or a pipeline from the Gulf Area are such alternative sources of additional natural gas imports to Western Europe.

Table 3 summarizes the 1980 natural gas balances in the four importing regions of Europe by listing the domestic production, imports, and exports. The exports by the three West European regions are relatively small and consist of 7 GWyr/yr exported from the Central (Netherlands) to the Southern (Italy) region. In addition, the North Sea exports more than 32 GWyr/yr to Central Europe, as was shown in Table 2, but due to the fact that the Norwegian part of the North Sea is treated as a separate supply source, it is not included in

Table 3. Domestic production is the lowest in South Europe when compared with total consumption, and is the highest in Central Europe. In other words, although Central Europe is the largest natural gas importing region, it is the least import-dependent on natural gas due to its relatively large domestic production (mostly concentrated in the Netherlands and the UK part of the North Sea).*

Table 3. Natural Gas Balance, 1980 (6 GWyr/yr).

Europe	Production	Import	Export	Consumption
North	1.2 ^a	1.2		2.4
Central	166.2	56.8	7.0	216.0
South	18.2	21.2		39.4
East	55.9	33.3		89.2
Total	241.5	112.5	7.0	347.0

^aAnother 32.3 GWyr/yr of natural gas is produced in the Norwegian part of the North Sea and exported directly to Central Europe, see Table 2.

The net import dependence on natural gas is actually lower than on oil imports and its products. Table 4 indicates that the overall import dependence for crude oil reaches almost 90 percent in Central and East Europe and actually exceeds 99 percent in the South. Only North Europe shows an apparent self-sufficiency with respect to crude oil imports due to relatively large production in the Norwegian North Sea fields. In comparison, the natural gas import dependence is still below 30 percent and is only slightly higher than the dependence on imports of solid fuels (mainly coal). In fact, if the Norwegian natural gas production in the North Sea were to be included as a domestic source, the natural gas import dependence in North Europe would appear to be even lower than that shown in Table 4.

Table 4. Primary Energy Net Import Dependence, 1980 (percent)^a.

Europe	Solids	Crude Oil	Natural Gas	Total ^b
North	42.1	57.3	50.0 ^c	33.6
Central	18.3	85.9	23.1	50.0
South	40.9	99.7	53.7	76.1
East		86.9	37.3	27.9
Total	23.3	174.5	65.3	82.4

^aOnly net imports are shown (i.e., imports-exports).

^bNuclear energy and hydro are imported only to the extent that electricity is traded.

^cNorwegian North Sea natural gas is not considered in this case.

*The gas flows between the member countries of the Commission of European Communities will be analyzed in collaboration with the GD XII of the EEC and Y. Smeers of the Center for Operations Research and Economics, University of Louvain.

Until now only the natural gas supply to Europe has been considered; in the following the actual use of the domestically available and imported natural gas will be considered. Table 5 shows the primary energy inputs to electricity generation in the four regions of Europe. In the three regions of Western Europe natural gas was by far the least used primary energy source in electricity generation, except in South Europe, where slightly more natural gas was used than nuclear energy. In East Europe, on the other hand, natural gas was the second most important source of electricity, preceded only by coal.

Table 5. Primary Energy Inputs to Electricity Generation, 1980 (GWyr/yr).

Europe	Solids	Petroleum Products	Natural Gas	Nuclear ^a	Hydro ^a	Total
North	5.1	5.8	0.5	11.4	40.9	63.7
Central	198.5	51.2	29.7	57.8	53.3	390.5
South	24.4	59.0	3.4	2.4	38.5	127.7
East	106.7	8.5	14.3	7.8	9.1	146.4
Total	334.7	124.5	47.9	79.4	141.8	728.3

^aGiven as primary energy equivalent, calculated on the basis of the amount of fossil energy that would be needed to generate the same amount of electricity.

On the aggregate level of the whole of Western Europe only about 13 percent of consumed natural gas was used for electricity generation. In East Europe it was slightly higher at about 16 percent. The share of natural gas consumption used for electricity generation for whole Europe is comparable to the share of crude oil consumption used for electricity generation (primarily in the form of heavy fuel oils) although the absolute amount of oil used in electricity generation exceeds the natural gas use by two and a half times. This indicates that natural gas is used as a premium fuel and is reserved to supply thermal uses in industry, households and services. Table 5 indicates that the opposite is true for coal--almost 60 percent of coal consumption was due to electricity generation. Nuclear energy and hydropower, naturally, were used exclusively for electricity generation.

Table 6 gives the installed capacity of electric power plants in Europe and Tables 7a and 7b the actual amounts of electricity generated by various primary energy sources. Therefore, Table 4 indicates the total energy inputs to electricity generation and Table 6 the achieved average output of electricity, so that the implicit efficiencies of electricity generation can be determined. Simple calculations indicate that natural gas was by far the most efficient source of electricity in the three regions of Western Europe, with an average conversion efficiency of 41 percent, followed by petroleum products with an efficiency of a little less than 37 percent and coal with 31 percent.

After primary energy is converted to secondary energy forms such as electricity and district heat, the secondary energy forms are transported to the vicinity of consumption centers and then distributed for final use. Energy transport and distribution cause losses so that the final energy actually available to the consumer represents a fraction of the original primary energy inputs to the system. Table 8 shows final energy consumption in the four regions of Europe. It indicates that about 27 percent of the original primary inputs were used in conversion, transport, and distribution steps throughout

Table 6. Maximum Net Installed Capacity of Electric Power Plants, 1980 (GW(e) installed).

Europe	Thermal	Nuclear	Hydro	Total
North	14.6	6.8	36.6	58.0
Central	202.1	33.6	50.7	286.4
South	58.1	2.8	39.0	99.9
East	65.6	3.9	10.4	79.9
Total	340.4	47.1	136.7	524.2

Table 7a. Electricity Generation Output by Primary Energy Source, 1980 (GWyr/yr of electricity).

Europe	Solids	Petroleum Products	Natural Gas	Nuclear	Hydro	Total
North	2.0	1.7	0.2	3.9	17.4	25.2
Central	62.5	19.7	12.2	19.8	18.2	132.4
South	7.2	21.5	1.5	0.8	13.8	44.8
Total	71.7	42.5	13.9	24.5	49.4	202.4

Table 7b. Electricity Generation Output, 1980 (GWyr/yr of electricity).

Europe	Thermal	Nuclear	Hydro	Total
East	48	2.6	3.0	53.6

Table 8. Final Energy Consumption, 1980 (GWyr/yr).

Europe	Solids	Petroleum Products	Natural Gas	Electricity	Total
North	15.2	56.1	0.7	24.2	96.2
Central	93.3	498.3	179.5	118.1	889.2
South	32.3	178.1	35.1	39.8	285.3
East	216.8	124.1	69.8	41.9	452.6
Total	357.6	856.6	285.1	224.0	1723.3

the energy system. In terms of total final energy consumption, natural gas has the third largest share after petroleum products and coal. In Western Europe it is the second most important final energy form after petroleum products. Such high shares of natural gas in final energy, compared with its low share in total primary energy, are due to the fact that it is not used heavily for electricity generation and because pipelines are a relatively efficient means of energy

transport. More than 82 percent of original primary natural gas is actually delivered to final use as natural gas and the rest is used for transport, dissipated as losses, or converted to electricity. In case of petroleum products more than 81 percent of consumed crude oil reaches the final consumer as a refined product. Only about 50 percent of solid fuels are directly consumed, most of the other 50 percent is used for electricity generation. In Western Europe almost 70 percent of primary solids are used to generate electricity.

Final energy is itself also not used directly, it has to be converted at the site of the user into useful forms such as heat or light. Table 9 reproduces the final energy consumption in Europe disaggregated by the type of end use. All of the specific electricity uses are grouped together. They include all uses of electricity that cannot be provided economically by other energy forms in the foreseeable future. Examples are the electricity uses for lighting or electrical appliances in the households. Also grouped together are all uses of light petroleum products in the transportation sector that cannot be replaced easily by nonliquid energy forms. Examples are diesel and gasoline fuels for automobiles, airplane fuel and so on. All other nonspecific final energy needs are shown in Table 9 under the two broad sectors of the economy--the household/commercial and industrial sectors. These energy uses basically include thermal energy needs such as low- and high-temperature heat in industry or air conditioning in private households or offices. The final energy consumption for thermal purposes is also given in the form of useful energy. Useful energy represents the actual heat needed to provide the service that results after the final energy is used in an end-use device such as a heating stove or a steel furnace. Thermal energy could be, at least in principle, provided by any final energy form: electricity, natural gas, crude oil products and solid fuels. Therefore, the useful energy requirements offer the largest potential market for additional uses of natural gas in the future in addition to more intensive electricity generation. The substitution process between natural gas and other final energy forms in thermal energy supply is usually called "burner tip competition". In the approach taken here of analyzing the future role of natural gas in Europe both with respect to natural gas trade at the primary side of the energy system and at the level of final use, structural changes throughout the energy system will be allowed that could lead to different trade and end use patterns.

Table 9. Final Energy Use, 1980 (GWyr/yr).

Europe	Thermal Uses ^a				Specific Electricity	Light Petroleum Products	Total
	Household/Commercial		Industrial				
North	25.4	(17.3)	27.0	(19.2)	17.2	26.6	96.2
Central	300.4	(201.3)	214.7	(154.4)	83.9	290.2	889.2
South	63.6	(42.4)	95.3	(68.4)	29.1	97.2	285.3
East	150.1	(88.3)	217.9	(150.6)	31.6	53.0	452.6
Total	539.5	(349.3)	554.9	(392.6)	161.8	467.0	1723.3

^aNumbers in brackets refer to useful energy.

REPRESENTATION OF END USE

In order to be able to analyze the possible changes in natural gas trade and end use patterns under different assumptions about the plausible futures, most of the relevant parts of the energy system of each region have been modeled by including all important natural gas conversion, transport and distribution stages as well as the equivalent transformation of other energy sources that compete with natural gas. On the other hand, not included with any degree of detail were final energy uses which are not likely to be supplied by natural gas. For example, it was assumed that natural gas will not compete with light petroleum products in providing motive power for automobiles, utility vehicles, and aircraft at least until the turn of the century. It was also assumed that natural gas will not compete *directly* in end use with specific uses of electricity such as light and power for appliances in households. However, it is possible that natural gas could be used more extensively to generate electricity.

As the two above examples about the simplification of end use of specific electricity and light petroleum products indicate, significant abstractions from the actual structure of the end use were assumed in order to emphasize the areas where natural gas has a substantial potential to increase its contribution to total energy consumption. Before proceeding with a more detailed description of this simplified and schematic representation of the regional energy systems as they are defined in our modeling approach, let us return briefly to the "front end" of the energy system and outline the representation of possible natural gas trade patterns in Europe.

REPRESENTATION OF NATURAL GAS TRADE

Table 10 gives the list of natural gas pipelines that were taken into service up to 1982 in Europe. Only the major pipelines that connect the regions are included. Table 10 indicates that a rather sophisticated grid for natural gas trade is already in place in Europe, allowing, at least in principle, a connection between any two regions (although not always in a direct way, but via some other regions). The Soviet Union can export to all four regions of Europe: it exports to Finland in the North and directly to East Europe, and through Czechoslovakia and Austria to both Central and South Europe. The Norwegian part of the North Sea is connected to the Central grid and therefore also to the South via Central Europe. North Africa is connected to Italy in South Europe with a pipeline and to Central and also South Europe by LNG routes.

Figure 1 illustrates all pipeline connections that have been considered between the five regions of Europe and the natural gas exporting areas. In addition to the links already in place described above, it is envisaged that during the next thirty years additional links could be established. A pipeline between Central and North Europe is already planned (from Denmark to Sweden). It is assumed that North Sea gas could be exported also to North and South Europe (perhaps both through Central Europe). Figure 1 also shows that the direct connections between any two regions are assumed to be only one-way with the exception of the possibility of a two-way flow between Central and South Europe. This is due to the fact that natural gas from the Soviet Union and the North Sea can be transported to the South through Central Europe. In addition, Central Europe already exports domestic gas to the South (the Netherlands to Italy). North Sea gas could reach the South also by an alternative direct link. In the opposite direction double paths are also possible: a direct path from North Africa to Central Europe and one via South Europe. Natural gas imports to East

Table 10. List of Interregional Pipelines in Europe.

Origin and Destination	Length (km)	Diameter (inch)	Capacity ^a (GW)
USSR to East			
Orenburg (SU) - Oujgorod (SU/CS)	4800	56	21.3 (33)
Medvezhe (SU) - Minsk (SU/CS)	3600	56,48	68.5 (106)
USSR to North (SU-SF)			
			1.2 (2.4)
USSR to Central			
Baumgarten (CS/A) - Oberkappel (A)	250	32	4.7
Oberkappel (A) - Ersching (D/F)	630	36,48	
Ersching (D/F) - Voisines (F)	704	30,32,36	
USSR to South			
Baumgarten (CS/A) - Tarvisio (I)	795	38-34	
North Sea to Central			
Ekofisk - Emden (D)	440	36	13.0 (31)
Frigg - St-Fergus (UK)	360	32,32	17.7 (24)
Brent - St-Fergus (UK)	510	36	5.9 (13)
Central to South			
Bocholtz (NL) - Mortara (I)	828	38-34	7.7 (12)

^aNumbers in brackets represent maximal capacity.

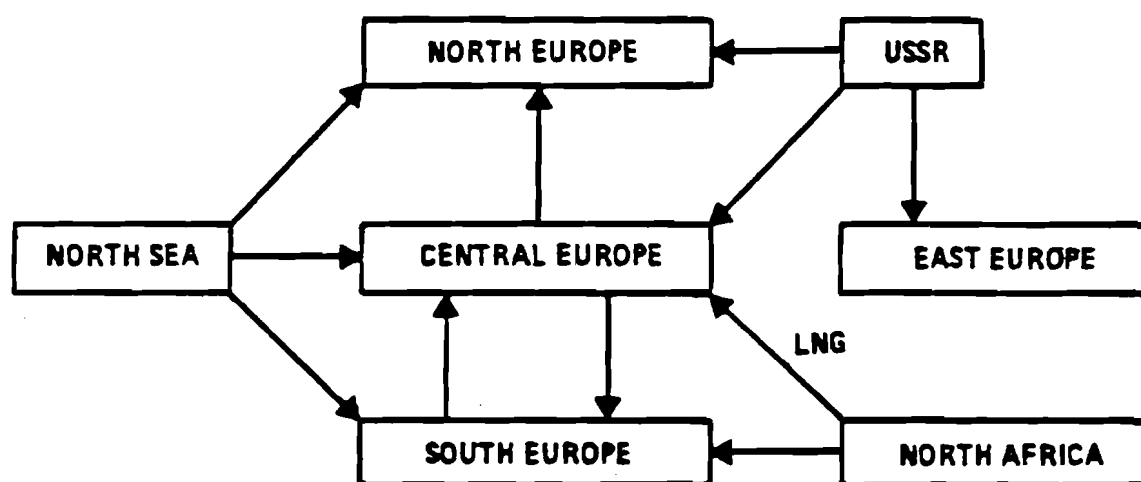

Figure 1. Possible Gas Flows.

Europe are assumed to come only from USSR and no other exporting area. Finally, in the current version of the model it is not envisaged that North Sea or Soviet gas could reach Central Europe through North Europe. The Project Gas Transit (PGT)* considers the possibility of transporting the North Sea gas through Sweden to Central Europe. Such additional connections between various parts of Europe may be incorporated at some later stage of the analysis.

The actual natural gas exchange that can take place through the links installed by a particular point in time is assumed to depend on the demand and the level of export prices which are intended to be similar to the current practice of FOB pricing. Natural gas is assumed to be sold to importing regions in Western Europe at market and not cost prices. Estimated "export earnings" are added to the extraction and transport costs incurred by the time natural gas reaches the border of an importing region. Thus, the actual difference between the costs of delivered natural gas and the price at which it is exchanged in the model (i.e., the export earnings) is exogenous. Here, it should also be mentioned that the crude oil price levels are assumed to represent "world market prices", and they are also specified exogenously. These price levels constitute two of the most important scenario specifications in our approach. As already mentioned in the introduction, a central point of the analysis involves the possibility of structuring the future energy system in Europe in compliance with more than one objective, thus the importance of costs and prices for the model results should not be overstressed. Nevertheless, they do play an important role in overall allocations and in the case where only a single objective of cost minimization is used, the relative prices especially of natural gas and crude oil would play a crucial role as well. Thus, the determination of the FOB natural gas prices over the level of actual natural gas delivery costs to the border of an importing region and the level of world crude oil prices constitute important exogenous parameters, but the rest of the price-formation process throughout the energy system is endogenous all the way to the level of end use.

After this brief description of the envisaged natural gas trade between the five regions of Europe and the natural gas exporting areas, let us return to the description of the energy systems internal to the regions. As mentioned, crude oil is assumed to be available in desired quantities on the international markets at a given price level. Natural gas availability is a more dynamic process that is dependent both on the actual extraction and transport costs and the "mark-up" of the costs to match FOB prices in North and South Europe. Coal imports are handled in a similar fashion as crude oil imports. It is assumed that coal is available in desired quantities on international markets at a uniform price. In Central and East Europe, on the other hand, the domestic coal extraction is considered explicitly in addition to coal imports. These three primary energy sources constitute the menu of envisaged imports by the regions.

THE ENVISAGED STRUCTURE OF THE ENERGY SYSTEM

Figure 2 illustrates schematically the possible configurations of the energy systems of North, Central, South and East Europe. In the Appendix the flow charts are reproduced in the same style for each region separately, but because they differ from each other only with respect to a few details, in Figure 2 we present a generalized form of the regional energy system that

*The Project Gas Transit (PGT) provides the basic decision data about a proposed route of a possible transit pipeline from northern Norway through Sweden.

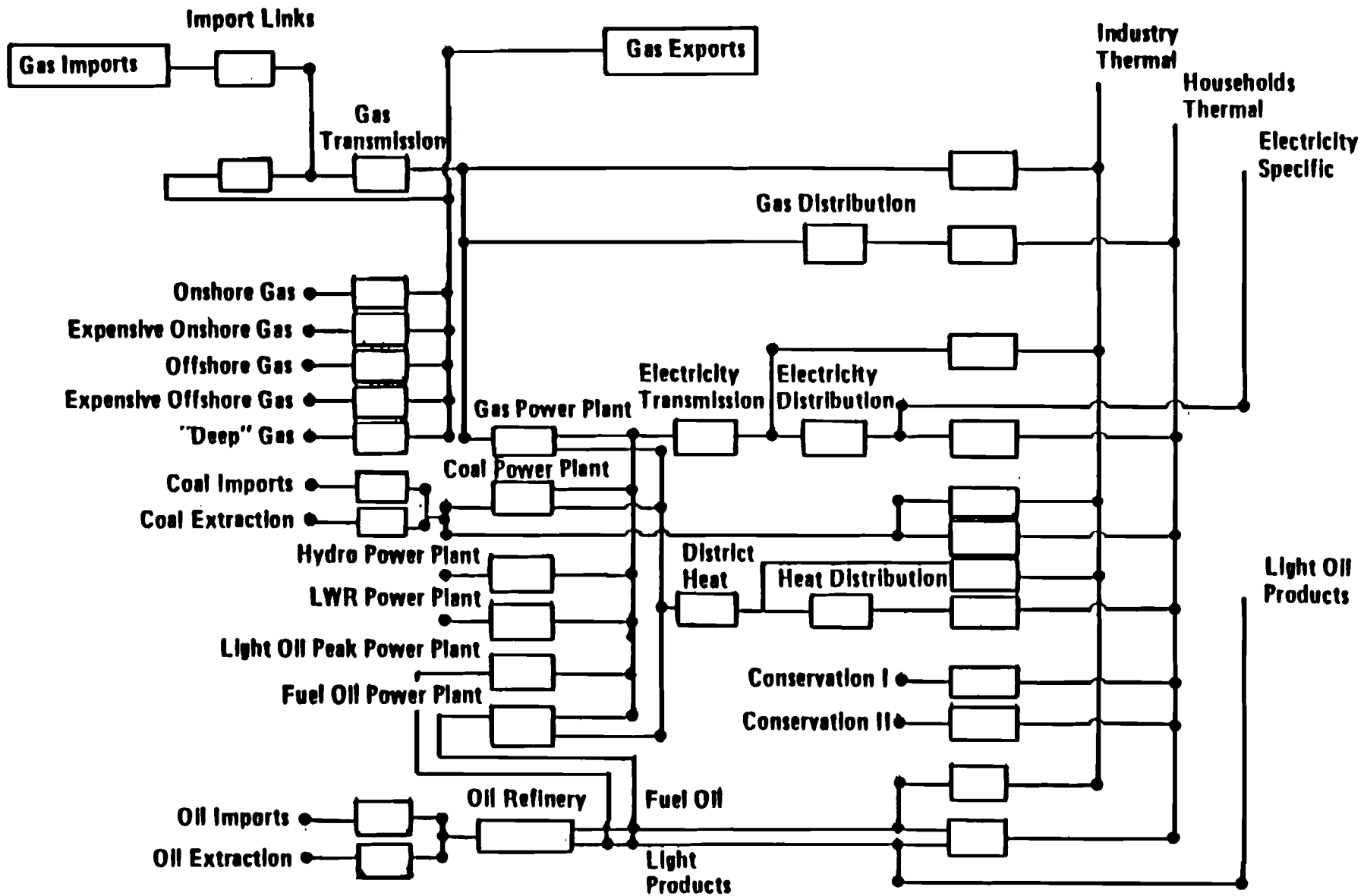

Figure 2. The Regional Energy System.

includes all features present in the four regions of Europe. The possible natural gas import links from Figure 1 are given in the left upper corner of the flow chart. In general the left side of the flow chart represents the primary energy inputs and conversion. Toward the right hand side of the chart, the flows represent energy transportation and distribution and the conversion of the resulting final energy to fulfill the useful energy requirements.

In addition to energy imports on the left side of the chart, the extraction of domestic energy resources is also given. Due to the fact that Central Europe includes both the UK and the Netherlands, it is provided with sophisticated possibilities for natural gas extraction both for offshore and onshore resources. In addition, the onshore and offshore gas extraction technologies are divided into an expensive and a less expensive class in order to represent the "easy" and the "difficult" extraction regimes. South Europe is assumed to be endowed only with onshore domestic extraction consisting of rather limited quantities of cheap gas and slightly more abundant amounts of expensive resources. East Europe is assumed to be able to continue domestic natural gas extraction and is assumed to have by additional reserves of more expensive resources. In the case of North Europe it is stressed again that the Norwegian North Sea gas is not included, neither in domestic gas extraction nor as a domestic resource. Thus, the only significant domestic natural gas extraction possible is the deep gas that could be discovered in the future. A point in case is the speculation about a deep gas find in the vicinity of the Siljan Crater northwest of Stockholm. South, East, and Central Europe are also assumed to have a potential of utilizing some "deep" (in the current version of the model very expensive) domestic gas resources.

In addition to coal imports, also domestic coal extraction in Central, South, and East Europe is envisaged. North Europe has only insignificant amounts of coal, so that for the purposes of this study it was not necessary to assume domestic extraction, although there are large efforts in North Europe to intensify wood and peat use both for generation of electricity and heat.

Coal is used in all four regions to generate electricity and heat. The thermal uses of coal are allocated endogenously between thermal uses in industry, and households and commercial sector.

Nuclear energy and hydropower are used exclusively for electricity generation today and, in the model, no other significant uses during the next three decades are envisaged with the exception perhaps of some applications of nuclear energy to low and high temperature heat. Accordingly the treatment of nuclear and hydropower is relatively simple. Each technology is represented by one homogeneous process in the flow charts.

Crude oil is assumed to be imported in all four regions. In fact the domestic extraction of oil is significant in Europe, but, nevertheless, because almost 90 percent of consumed oil is imported (see Table 4), the representation of domestic production and oil imports as one activity in the model is not a very unrealistic assumption for the purposes of this study. As already mentioned, crude oil is available to all regions at two uniform price levels. Total crude oil inputs are refined to produce two products in variable proportions--the light derivatives (such as gasoline) and heavy fuel oils.

The demand for light fuel products in the transportation sector is exogenously specified, but they can be used also to meet some of the thermal needs in households and the commercial sector. There is an additional possibility of employing light oil products in an electric peak power plant.

Heavy fuel oil is used both in electricity generation and to meet thermal energy needs in industry. In Central Europe it is also available for thermal uses to the household and commercial sector.

After conversion of primary energy, all resulting secondary energy forms are transported and distributed to final uses. As was explained above these uses consist of useful thermal energy needs in industry and in the household and commercial sector. Various final energy forms (i.e., electricity, natural gas, etc.) compete in meeting useful energy demands, each through its specific final conversion device such as electric air conditioning or natural gas heaters. An additional feature at the final energy level are the two "conservation technologies" which are associated with costs and represent energy savings achievable by two levels of better insulation of buildings and other similar conservation measures.

The specific electricity and light oil product demands are specified explicitly at the final energy level. Thus, this approach allows dynamic changes at the level of useful energy which then result in different allocations of various primary energy inputs to meet the demands after the necessary conversion, transport, and distribution stages. Different energy allocations also cause a restructuring of the energy system as such, because they usually necessitate investments in infrastructure and equipment. Because the whole system is interdependent, the cause of changes made throughout the energy system could also originate at the level of energy imports, for example, after a change in relative prices of crude oil and natural gas imports. However, in this approach prices need not be the (only) criterion for allocation because allowance is made for specification of multiple objectives with or without explicit cost minimization.

A last component of the energy system in each region constitutes the sulfur oxide emissions that result from the use of fossil energy forms. The schematic representation of energy flows (see Figure 2) from primary to useful energy does not illustrate this accounting of emissions. Here again, a simplified approach is adopted by treating each energy form as a homogeneous source of sulfur emissions, but it accounts for different emission levels due to different technological possibilities at all stages of energy conversion. For example, the possibility of employing scrubbers to reduce emissions of coal power plants is provided for.

In the next section a brief description is given of the principle method to derive a multiobjective criteria to determine the optimal structure of natural gas trade and energy system configuration in the five regions of Europe.

THE MULTI-OBJECTIVE APPROACH

Like most other models that are used to describe complex systems, the model set represents a flexible tool for analysis. Consequently, the user has a multitude of control mechanisms available for the description of general scenarios about the future and his objectives. In the extreme case, almost the whole structure of the models could be changed. Such extreme possibilities could include, for example, the introduction of new technologies for energy conversion or trade not foreseen in the current structure of the regional models. Another example would be the introduction of a new allocation criterion that is not available in a particular realization of all theoretically possible objectives. While all such changes could be implemented, they would necessitate new links throughout the energy system or a new set of relations

specifying the new objective. Depending on particular details, they may require additional modeling effort and would not constitute mere input changes.

A primary goal of this effort was to simplify the introduction of changes that do not require the restructuring of potential links between regions and technologies or introduction of completely new objectives. Such changes can be implemented instantaneously and should require only a few minutes of run-time before a new solution is obtained. The available potential structure of the energy system that can be used without the need for major changes is described in the previous section. All components of the described systems could be included by the user in an interactive mode with the model.

All of the objectives that are available to the user as criteria for the allocation of energy systems modeled in our approach are "built-in" options just as the described potential structure of the energy systems. As was mentioned above, the introduction of new objectives would necessitate additional model changes that cannot be implemented in an interactive mode.

First a description is given of the possible objectives and then an illustration on how they can be combined to generate an optimal solution. The available objectives could be grouped in two classes: the objectives that are defined for single regions and those that are defined for all regions. In fact all of these objectives refer to possible natural gas export strategies by the three exporting areas. It is assumed that the USSR would maximize its total revenues from natural gas exports (i.e., total export volume times average price). This objective would be consistent with an attempt to maximize the foreign currency returns through natural gas exports, but it need not be consistent with profit maximization. On the other hand, it is assumed that North Sea and North African exports would be guided by the profit maximization principle (i.e., total revenue minus total costs). The logic behind such diverse export criteria is rather simple. The USSR has vast natural gas resources when compared with the maximal potential consumption of whole Europe accumulated over the time horizon of three decades. Thus, here it would make little sense to maximize production, since the realization of such a strategy in the model would flood the European natural gas "market". In the case of North Africa and the North Sea, the potential export volumes are less impressive (due to limited potential transport possibilities to Europe in the case of North Africa and limited resources of moderately priced gas in case of the North Sea). Therefore, in the case of these two exporters it makes sense to maximize profits or to follow a given natural gas revenue trajectory.

The second set of objectives refers to other parts of the energy system and concerns all regions in the same way. First of all, the possibility of cost minimization of the whole regional energy system has been included. This is the classical objective of most modeling efforts. At the same time, the objective of minimizing sulfur emissions resulting from the use of fossil energy sources has been included. If enforced, this objective would tend to enforce the proliferation of natural gas use because of its advantageous environmental qualities (in this case low sulfur content).

The last objective on the list is perhaps controversial. It specifies the maximization of useful energy consumption of the household and commercial sector. At face value this objective may appear to be contrary to the efforts to reduce energy consumption. This is not necessarily so, because conservation is included in the energy system as one of the ways of providing useful energy in the household and commercial sector. In addition, the maximization of useful

energy leads to the evaluation of the upper limit on future energy availability as specified in the models.

The actual specification of the criteria is preceded by the determination of the important scenario characteristics. The most important of them specify the relative cost structure of various technologies and their market penetration constraints, the future development of energy demand, and the resource availability. All of these specifications are, of course, provided in the "reference" scenario and they need not be changed, but the model provides the possibility to specify these scenario characteristics in an interactive mode. In particular, the relative prices of crude oil and natural gas represent some of the most important specifications as far as the structure of the resulting energy system and natural gas trade is concerned. The specification of future energy demand involves the definition of useful energy needs in industry and household/commercial sectors and the definition of the final energy requirements for specific uses of electricity and light oil products. These demand trajectories over the time horizon of three decades are also given in the reference scenario. They are based on the IIASA'83 Global Scenario of Energy Development (see, Rogner 1983), but if changed they would tend to have a substantial influence on the structure of energy end use and natural gas trade.

Once these scenario characteristics are specified, the model can provide a set of indicators for the "achievability" of various objectives that were specified above. By this it is meant, for example, that the model can determine the cost minimal energy system still compatible with the scenario specifications, the minimal sulfur emissions achievable under the given constraints, or the maximal revenues to be reached from natural gas sales, and so on. At the same time, the model can also provide the "worst case" values for these objectives, i.e., the worst imaginable result in the direction of each particular objective within the given constraints. Thus, the user can be provided with a set of maximal and minimal values for each objective over the time horizon of thirty years. Using these extreme values as bounds, the user can specify a trajectory for each of the objectives that should be followed by the model as close as possible.

This multiobjective optimization approach is described in detail in Wierzbicki (1983) and Grauer (1983). Here only an indication is given on how it works. A linear modeling approach is used to represent the energy system structure of the four regions of Europe and also the same technique for modeling the natural gas trade between the regions and exporting areas. Once all characteristics of the linear modeling structure and possible objectives are defined, the model determines the solution that would correspond to the achievement of all objectives. Due to various constraints and limitations imposed on various activities, such a point is usually not feasible but it represents a hypothetical case where all aspirations materialize. Appropriately it is called the utopia point.

The other extreme situation, called nadir point, represents the worst value of each objective obtained by optimizing the values of all other objectives one after the other. This situation is definitely least desirable, but it is interesting to note that it could also be infeasible because there may be a conflict with bounds set on some activities. The model generates the utopia and nadir points for all time steps and the user has the option to specify the trajectories for each of the objectives that stay within the bounds provided by the utopia and nadir points. The model then determines the solution that is the "closest" to the specified objectives but still consistent with constraints and limitations set on the activities. A more technical reader is referred to an

illustrative introduction to the topic of multiobjective analysis by Grauer, Lewandowski, and Schrattenholzer (1982), Grauer (1983), and Wierzbicki (1983).

CONCLUSION

The model of natural gas production, trade, and use that was described in this paper was developed to be used interactively for the analysis of different scenarios of natural gas projects in Europe during the next thirty years. The intention was not to develop a single set of model results. Instead, a modeling tool has been developed that can assist the user to define his images of the future interactively using the model. The model presented in this paper offers the structure for the analysis in a similar way as the computer is used by a programmer. The main advantage of such an approach is that it is possible to generate many different scenarios with basically the same consistency criteria and similar basic philosophy. Thus, it is possible to investigate the effects of changing various assumptions about the natural gas production, trade, and use in Europe. The comparison of such different scenarios can help to identify sensitive issues and critical aspects of more extensive use of natural gas in the future.

The basic structure that is invariant from one scenario to another is the base year description, the choice of possible objectives to use in a given scenario, the type and general characteristics of technologies included in the energy system, and so on. The user can specify according to his preferences the trajectories of various objectives to be achieved (to the extent possible) by the optimization, he can specify the structure of energy costs and prices, especially the international price of crude oil and the FOB price of natural gas, natural gas reserves available to various regions in Europe and gas exporting areas, etc. Like any other tool, the model needs external analysis for appropriate application, and it is envisaged that this information would be provided by the user. In the next Working Paper, we will present some interesting scenarios of the natural gas future in Europe that were developed with the help of the model. It will probably be necessary with time to introduce some modifications in the whole approach in order to offer new possibilities that will be discovered by the use of the current version of the model. From this point of view, the use of the model is envisaged as an ongoing activity that would serve to identify further topics of research that cannot be adequately addressed at the present time.

References

- Grauer, M. (1983) *A Dynamic Interactive Decision Analysis and Support System*. WP-83-060. Laxenburg, Austria: International Institute for Applied Systems Analysis.
- Grauer, M., A. Lewandowski, and L. Schrattenholzer (1982) *Use of the Reference Level Approach for the Generation of Efficient Energy Supply Strategies*. WP-82-019. Laxenburg, Austria: International Institute for Applied Systems Analysis.
- Organisation for Economic Cooperation and Development (OECD)(1982) *Energy Balances of the OECD Countries*. Paris, France.
- Rogner, H-H. (1983) *IIASA'83 Scenario of Energy Development: Summary*. Laxenburg, Austria: International Institute for Applied Systems Analysis.
- United Nations (UN)(1983) *Yearbook of World Energy Statistics*. New York.
- Valais, M., P. Boisserpe, and J.L. Gadon (1982) *The World Gas Industry*. Fourth Edition. Paris: Institut Francais du Petrole.
- Wierzbicki, A. (1983) *Negotiation and Mediation in Conflicts I: The Role of Mathematical Approaches and Methods*. WP-83-106. Laxenburg, Austria: International Institute for Applied Systems Analysis.

Appendix

NORTH EUROPE

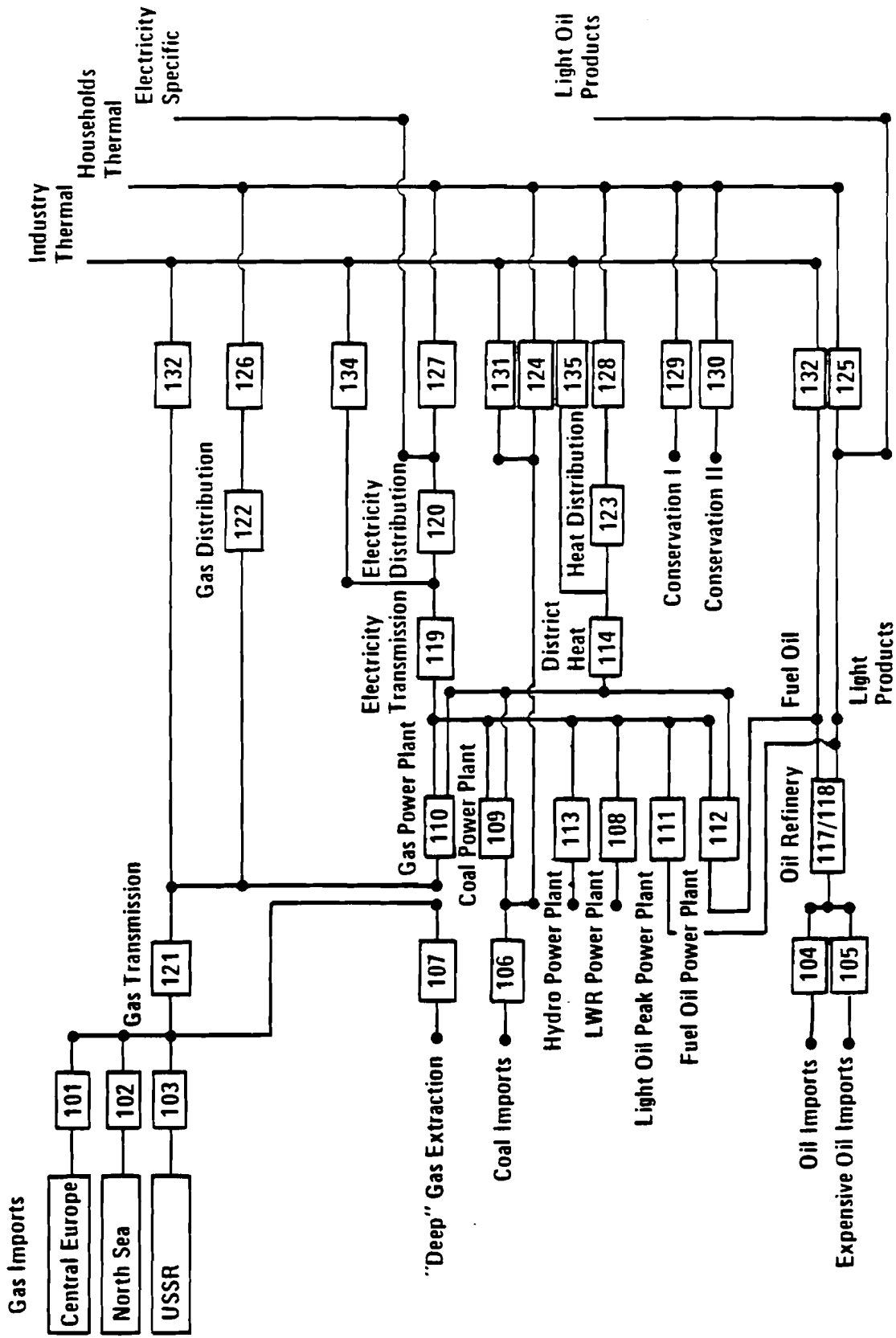

CENTRAL EUROPE

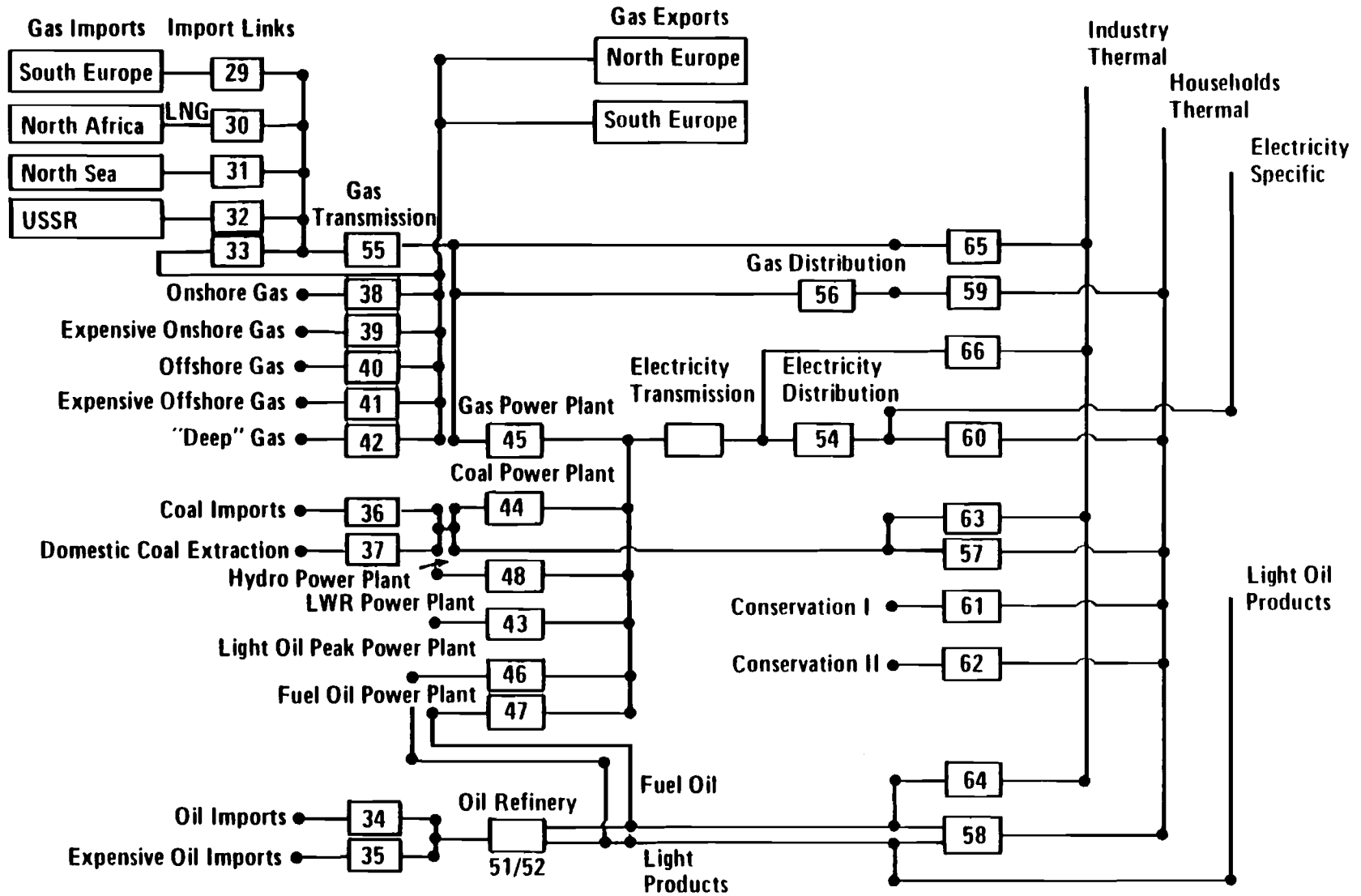

EAST EUROPE

Gas Imports Import Links

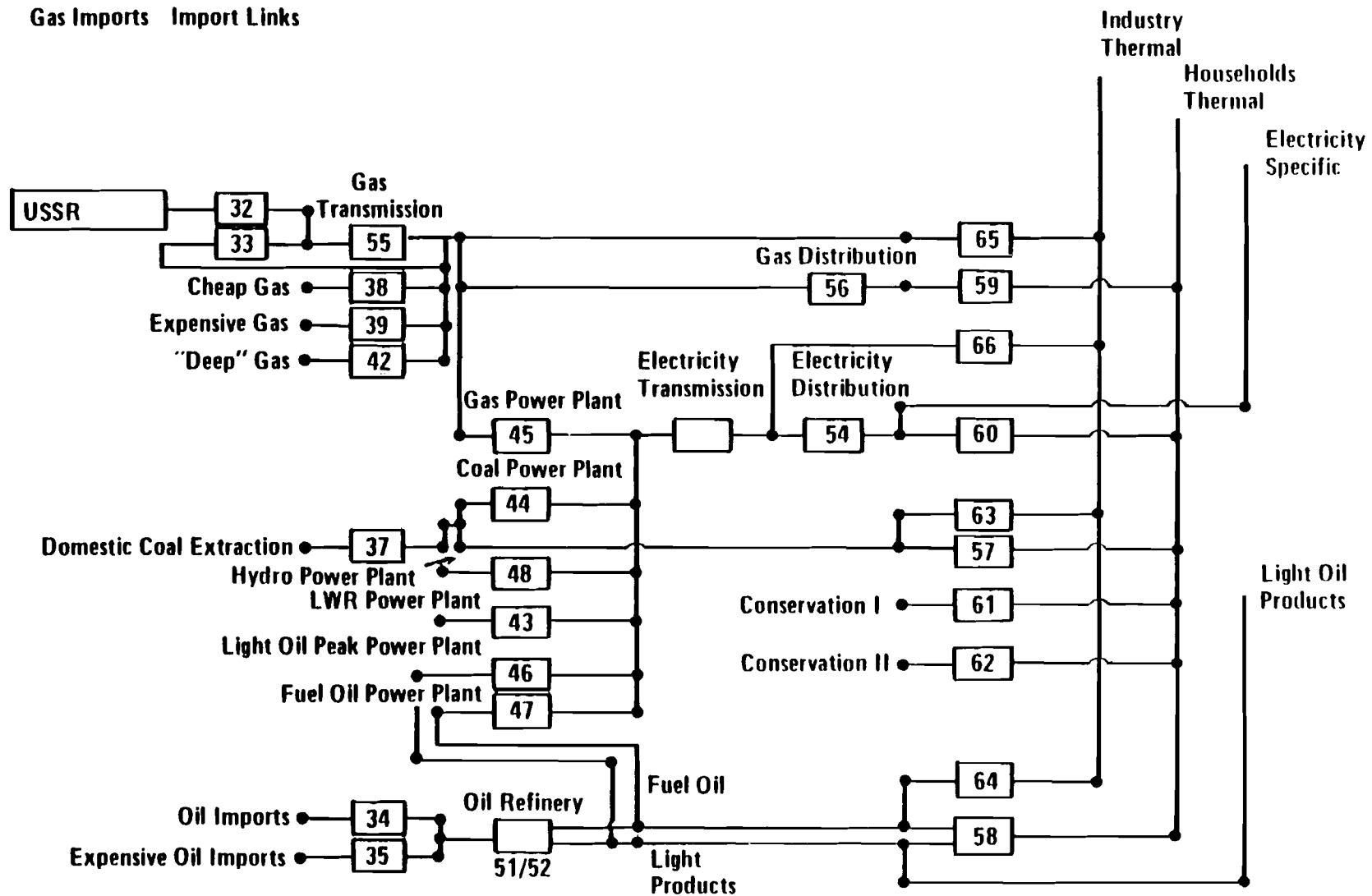

SOUTH EUROPE

