

# **The Tuscany Interregional Input- Output Model (TIM): Mathematical Structure and Preliminary Results**

**Martellato, D.**

**IIASA Collaborative Paper  
June 1982**



Martellato, D. (1982) The Tuscany Interregional Input-Output Model (TIM): Mathematical Structure and Preliminary Results. IIASA Collaborative Paper. Copyright © June 1982 by the author(s).  
<http://pure.iiasa.ac.at/2088/> All rights reserved. Permission to make digital or hard copies of all or part of this work for personal or classroom use is granted without fee provided that copies are not made or distributed for profit or commercial advantage. All copies must bear this notice and the full citation on the first page. For other purposes, to republish, to post on servers or to redistribute to lists, permission must be sought by contacting [repository@iiasa.ac.at](mailto:repository@iiasa.ac.at)

NOT FOR QUOTATION  
WITHOUT PERMISSION  
OF THE AUTHOR

THE TUSCANY INTERREGIONAL INPUT-  
OUTPUT MODEL (TIM): MATHEMATICAL  
STRUCTURE AND PRELIMINARY RESULTS

Dino Martellato \*

June 1982  
CP-82-30

\* Faculty of Economics and Commerce  
University of Venice  
Venice, Italy

*Collaborative Papers* report work which has not been performed solely at the International Institute for Applied Systems Analysis and which has received only limited review. Views or opinions expressed herein do not necessarily represent those of the Institute, its National Member Organizations, or other organizations supporting the work.

INTERNATIONAL INSTITUTE FOR APPLIED SYSTEMS ANALYSIS  
A-2361 Laxenburg, Austria



## PREFACE

Specialization is one of the foremost traits of modern industrial development. Technical and commercial factors have interacted to make large-scale production more profitable than earlier. This process has been concomitant with a regional concentration of production activities according to the prevailing comparative advantages. Even large, and strong, economic regions tend to have an insufficiently differentiated economy. In Tuscany, Italy, it is the leather, footwear, and textile industries that constitute the economic backbone of the region. They are complemented by, and competitive with, the traditional tourist industry.

Technical progress and the development of factor costs have entailed a shift in international and interregional comparative advantages. Those industries demanding only low-skilled labor have expanded in low cost countries or regions. How these factors will affect the long-term development is a general problem of strongly specialized regions in industrialized countries.

Such questions are also at the core of the case study of systems analysis for regional industrial development undertaken by the Regional Development Group, IIASA, in collaboration with the Regional Institute for Economic Planning of Tuscany (IRPET). A third party in this collaboration is the Institute for Applied Systems Analysis (IASI) of the National Research Council, Rome. In the case study, a system of economic forecasting and policy evaluation models that address the above-mentioned development issues are being built. The models have a stronger emphasis on interregional and international dependencies than earlier regional studies. Moreover, the role of the regional authorities in policy generation and evaluation is more clearly designed here than elsewhere. The aim of the work is to develop a computerized model system for more or less permanent use, with a direct applicability to other urbanized regions of the Tuscany type.

The Tuscany interregional input-output model (TIM) described in this paper forms the core of the economic forecasting and policy-evaluation model system. TIM is a linear static recursive system of equations of small dimensions that is intended as a tool for analyzing the trade relations of Tuscany. Tuscany and the Rest-of-Italy are considered as two regions in TIM. Each one is linked to the rest of the world where exports are exogenously determined. Foreign trade is taken into account by distinguishing between national and international flows. Complementarity and competitiveness of imports are considered in this model.

Laxenburg, June 1982  
Boris Issaev  
Leader  
Regional Development  
Group  
IIASA

THE TUSCANY INTERREGIONAL INPUT-OUTPUT  
MODEL (TIM): MATHEMATICAL STRUCTURE  
AND PRELIMINARY RESULTS

Dino Martellato

1. THE SCOPE OF THE INTERREGIONAL INPUT-OUTPUT  
MODEL OF TUSCANY (TIM)

The decision to carry out an in-depth study of the linkages of Tuscany with the rest of Italy and the world, with special reference to trade relations, is based on two factors. The first is that trade is extremely important for Tuscany. It does not make sense to study--however accurately--its economic system in isolation. The second is that a number of regional growth disparities can be explained simply by the competitive position of the export sectors of the different Italian regions.

The increasing popularity of interregional input-output analysis can be attributed to its capacity to deal with these phenomena. In such an analysis the emphasis is diverted from the movement of production factors to the movement of products.\*

---

\* It concentrates on the equilibratory (or disequilibratory) effects of the mobility of products rather than of the production factors. A surplus region often has a more rapid growth in output. The growth in productivity and the introduction of innovations will, accordingly, be more sustained. These factors will enhance the comparative advantage of the region and probably polarize the mobility of labor and capital.

Furthermore, it is quite important to pay attention to the balance of trade at the regional level, even if there are no problems for a balance of payments in foreign exchange. The regional balance of trade may be significant from another point-of-view. It may be asserted that the tighter the trade linkages, the stronger will be the instability of a system of regions.

Because of the lack of a foreign exchange constraint and the high regional mobility of capital, a region can become steadily in deficit. This will not necessarily be an advantage because its deficit has to be counterbalanced by income and capital transfers. The income transfers are, however, usually channeled through the public sector and the capital transfers through the credit and public sector. This means that the central (tight) fiscal and monetary policies will not be spatially neutral. To summarize:

- it is useful to concentrate on trade rather than on factor mobility because the latter may simply be a result of the former;
- the stronger the regional connectivity, the higher the instability of the system of regions;
- regional trade may be permanently imbalanced and this means cumulative growth in the surplus regions and/or non-spatial neutrality of fiscal and monetary policies.

The main focus of the analysis carried out with the inter-regional input-output model will then be on the trade linkages of Tuscany. This means that from the outset of the analysis consistency between production and trade will be embedded in the model.\* In the following stage of the analysis, more attention will be given to consistency between production and final internal demand. Underlying this approach is the assumption that the internal level of economic activity is strongly connected with trade, while consumption and investment show weaker linkages with the level of production. Internal consumption is indeed dependent also on income transfers, and investment may certainly be pulled by the level of current

---

\*The model will have a simultaneous solution only for production and trade, with a given exogenous demand.



production, but would tend to have a high import content. Thus, the building of an interregional input-output model with a strong orientation to the analysis of trade relations is expected to require a considerable amount of information on the trade relations of the region (Cavaliere 1980).

At the present time, however, this information is not available in sufficient detail, particularly for trade with the rest of Italy. IRPET\* will, in any case, produce the necessary basic statistics with its direct input-output table for 1978. As regards foreign trade, considerable improvements with respect to the 1975 table have already been obtained with the indirect 1977 input-output table, while further insights will also be provided by the current research done by IRPET.

Because the interregional input-output model for Tuscany (TIM) is intended as a tool for both accounting and policy analysis, it has to accept the statistical conventions used by the current system of national accounts. It should also present its results in a way that is clear to the policy-maker.

This means that the treatment of imports and production at a regional level deserves much attention, because we have to choose between a number of accounting procedures that have different effects on the multipliers. The usefulness of the model for policy analysis rests not only on its ability to represent the actual working of the system accurately, but also on the seemingly minor accounting characteristics given to the model. For import flows, for instance, we have a range of solutions. If, from the outset, we are able to make a distinction between what is produced internally and what is imported, we can accommodate all the imports in a row at the bottom of the input-output table. In this case, we can make a pure complementarity hypothesis, which enables the actual internal impact of the level of production to be measured. This solution has, however, two drawbacks: insomuch as part of the imports are competitive in nature,

---

\* IRPET is the acronym for Istituto Regionale per la Programmazione Economica della Toscana. The institute is located in Florence, Italy.

the computed column coefficients will be unstable; furthermore, its statistical requirements are quite demanding. Conversely, if we consider all the intermediate flows, disregarding their geographical origin, the computed coefficients are more stable and the statistical requirements are reduced.

In this purely competitive hypothesis, however, we have to subtract from the exogenous vector of final demand the vector of total imports. The implication in this case is clear: we have to forecast exogenously the level of imports by sector, which is the solution that is expected from the model. The basic idea of the interregional input-output model is exactly this: to specify appropriate side conditions in order to make interregional imports and foreign imports endogenous. The model has also to make an unbiased split of total imports into regional and foreign imports if the available data does not distinguish between interregional and international trade, as occurs often.

Similar arguments can be put forward for production\*. When we refer to a single vector, its effective production ( $x$ ) is different from its distributed production ( $p$ ) by an amount ( $z$ ) equal to the value of its by-products and joint-products:

$$p = x + z \quad . \quad (1)$$

For the region as a whole, there is no difference because the transfers of production between sectors simply sum to zero. The distinction is relevant for the computation of Leontief coefficients for the different sectors. If we compute these coefficients over distributed production, the intermediate consumption is  $\bar{A}p$ , and the equilibrium relation for disposable resources

$$p = \bar{A}p + f$$

has an obvious solution. In this case, the vector of transfers of production does not appear in the model, but we cannot call the elements of  $\bar{A}$  technical coefficients.

---

\* We disregard imports for the moment.

We can compute such coefficients only over the effective production, but the equilibrium identity is still defined for distributed production. The system of equations

$$p = Ax + f$$

can be solved only if we insert definition (1):

$$x = (I-A)^{-1}(f-z) \quad . \quad (2)$$

This is certainly more stable than the preceding relation because the matrix  $(I-A)^{-1}$  is a true Leontief inverse. Nevertheless, it can be used for forecasting purposes only if one has a forecast for  $f$  and for  $z$ .

A rather crude assumption of homogeneity will be made in the following

$$z = Zx, \quad (3)$$

which allows us to circumvent the difficulty in obtaining a forecast for  $x$ , because the diagonal matrix  $Z$  is simply kept fixed at its historical level.

A third, and more difficult, problem is encountered when constructing an input-output model from an input-output table built according to the so-called EEC methodology. It is the treatment of the sectoral input of credit services. Their amount, which is considerable, is not distributed among the rows, but is kept in a dummy column as intermediate consumption. The dummy industry then has a negative value added and a zero production. In this way the national value is corrected for its positive bias due to the fact that the intermediate consumption of the  $n-1$  sectors is negatively biased. This is, however, only an accounting trick, which does not help the modeler because he has to choose between two ill-posed alternatives: invert a rectangular  $[n \cdot (n+1)]$  matrix, or after consolidation of the credit column with the dummy column, invert a square matrix, which is no longer a Leontief matrix. The coefficients of the credit column indeed add up to a number greater than one, the inverse is no longer non-negative everywhere and the solution

vector may be negative in some of its elements. We choose to keep the value of the dummy column out of the invertible matrix. Then we solve the model for the reference year (1975) in the usual way and check the production obtained with the known vector. The discrepancy (which is always negative and in most cases negligible) gives a clear measure of the bias of the computed multipliers. They are then corrected by a coefficient, greater than unity, equal to the bias and kept constant along rows. In this way, unbiased Leontief multipliers can be obtained from biased inter-industry flows.

## 2. FROM THE LIMITED INFORMATION TABLE TO THE FULL INFORMATION TABLE WITH A TOP-DOWN APPROACH

The purpose of TIM from a pure accountancy point-of-view is to build (firstly for 1975, and in the future for 1978) a full information (FI) system of input-output tables for Tuscany and the rest of Italy.

Before defining full (or limited) information tables, it is useful to note that both for 1975 and 1978 a top-down approach will be used, the difference being that in the latter case the amount of fresh data gathered at the regional level is much greater.

For 1975, IRPET has developed a limited information (LI) table (MIT 75) by regionalizing a corresponding national table for 1974 on the basis of some indirect information at the regional level (Marliani 1981). We then computed residually the table for the rest of the country (Figure 1).

IRPET then estimated the table for 1977 (see Figure 1). Unfortunately, the national table for 1977 will not become available; the construction of an LI biregional table for the year will therefore be impossible. The 1977 table will, however, be used for a sensitivity analysis of the model (TIM 75) built upon the 1975 data base.

IRPET is currently building a direct table for the year 1978. When the corresponding official national table becomes available, the LI table and the corresponding model (TIM 78) will immediately be obtained simply by using the procedures

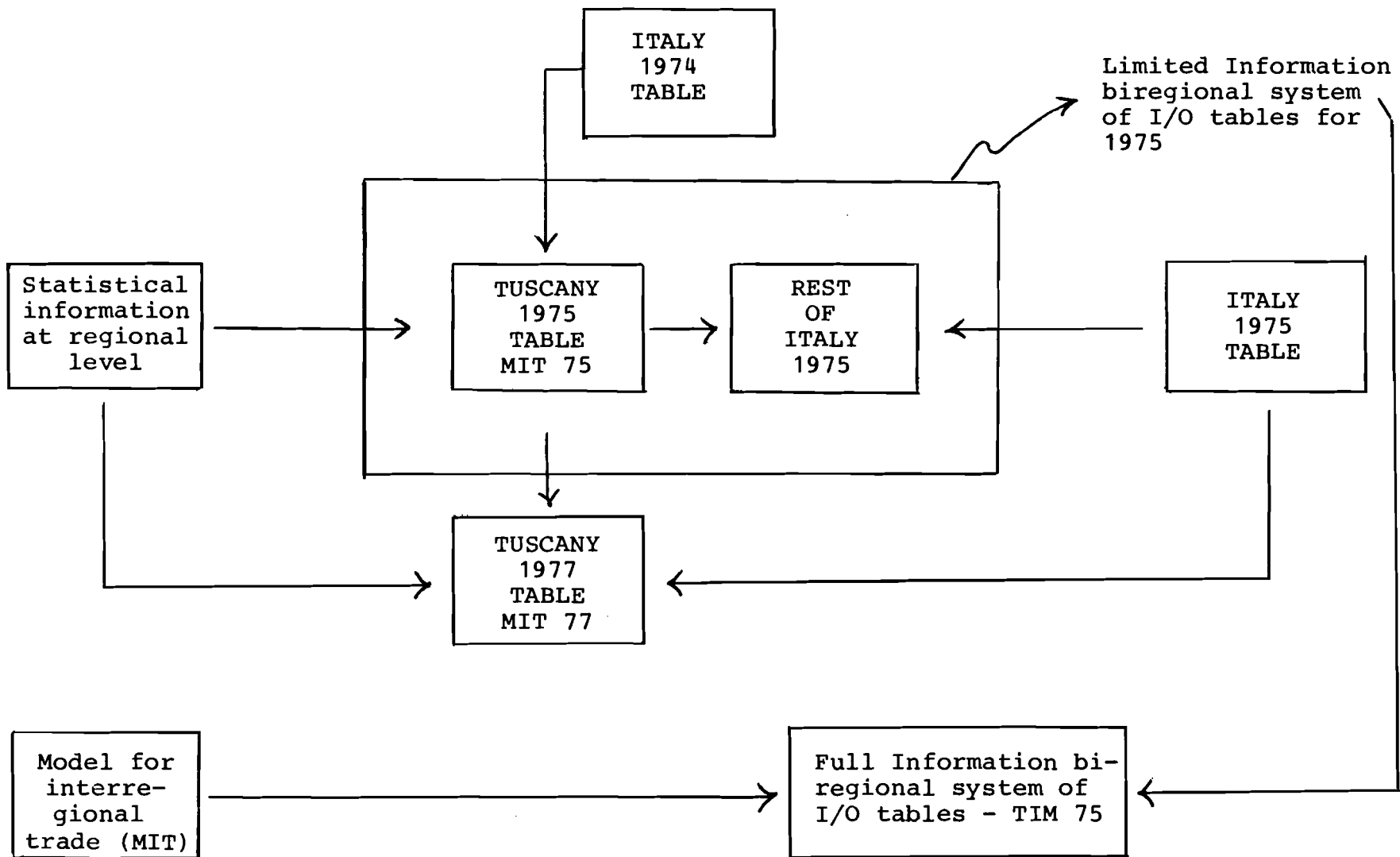

Figure 1. The derivation of TIM 1975.

implemented for 1975. It is now clear why the analysis rests on a top-down approach for 1975: both regional tables are obtained from a break-down of the national table.

We will now clarify the terms limited information (LI) and full information (FI) tables (see Table 1).

INTERNAL INTERMEDIATE FLOWS TUSCANY	INTERMEDIATE EXPORTS FROM TUSCANY TO REST OF ITALY	PRIVATE CONSUMPTION	PUBLIC CONSUMPTION	TOTAL INVESTMENT	REGIONAL EXPORTS TO THE FINAL SECTOR	REGIONAL IMPORTS TO THE FINAL SECTOR	FOREIGN IMPORTS	FOREIGN EXPORTS	DISTRIBUTED PRODUCTION DEP. USINE	EFFECTIVE PRODUCTION DEP. USINE	INDIRECT TAXES	IVA	TRANSFERS OF PRODUCTION AVAILABLE RESOURCES DEP.	USINE	
INTERMEDIATE IMPORTS TO TUSCANY FROM REST OF ITALY	INTERNAL INTERMEDIATE FLOWS REST OF ITALY														
1	31 32	62	63	64	65	66	67	68	69	70	71	72	73	74	75

Table 1. A Full Information input/output table.

In an LI biregional system of tables, production in every sector of every region is equal to total intermediate and final demand in the region (disregarding geographical origin) plus exports to the other region and plus exports abroad.

In an FI biregional system, on the other hand, the same level of production is decomposed into intermediate demand satisfied in Tuscany, intermediate demand satisfied in the rest of Italy, final demand in Tuscany, final demand in the rest of Italy, exports abroad, imports from abroad, and available resources.

It is now clear why an FI table gives much more information on the internal production structure and on trade flows between regions. Considering, furthermore, that a part of regional trade is actually a kind of indirect foreign trade, we will also try to disentangle this component in the FI table. The result is a break-down for one year between the two regions of all the considered economic aggregates.

The possibility of transforming the LI table into an FI table rests basically on the availability of the interregional trade flows. The estimation of these flows is not possible, however, if interregional shipments are not statistically observed. This is why IRPET has derived a vector of net regional trade balances only. The vector has been obtained simply as a residual, taking as a constraint official regional economic accounts and data on foreign trade, which means that the residual is gross of inventory change and indirect taxes on foreign imports (Marliani 1981). IRPET has an estimate of the gross absolute value of interregional exports and imports that will be used in the first implementation of TIM. The methodology used in this estimation will be considered in Section 5 in connection with an illustration of the possibilities for improving the estimate of trade coefficients.

### 3. THE CHOICE OF MODEL

We can now present the structure of the interregional model based on the statistical information discussed above. First, we have to decide what should be considered as exogenous and what should be endogenous in the model. Then, we have to choose between a fixed trade pattern coupled with a flexible production pattern and a flexible trade pattern coupled with a fixed production pattern. The first point obviously depends upon the degree of interaction we wish to develop in the model at the present time. It should be mentioned that this degree will, for the moment, be well below that of the consistency we desire for the forecasts. The reason being that this degree of consistency

requires the solution of a consistent set of models, which are currently being developed.\*

The second problem has strong connections with the specific economic context with which we have to deal. If we have to face a situation of full utilization of capacity, it seems more appropriate to have a fixed-output flexible-trading pattern in the model. But if the economy is running below its potential, we must resort to a flexible-output with a fixed-trading pattern (Martellato 1981). In this case, the fixed-trading pattern is simply the observed (almost indirectly) pattern of regional trade.

At the present stage of the study, we are only prepared to make production, regional trade, foreign imports and employment, which are the standard features of an interregional input-output model, endogenous. However, as mentioned previously, the ongoing research on the Tuscany case study should allow us to develop a system of models for forecasting exports abroad, consumption, and the supply of labor.

In the context of the specific submodel presented in this paper, more attention will be given in the future to the endogenous treatment of private investment and to the relation of the stability assumption of trade coefficients.

Thus, we will start with a flexible-output and fixed-trade pattern model of the Chenery-Moses family. Essentially, we have a set of supply equations, a set of demand equations, and a set of regional trade balances.

We use the following notation for vectors (small letters) and matrices (capital letters):

x = effective production;  
f = internal final demand plus exports abroad;  
m = foreign imports;  
g = f - m;

---

\* We refer to models for the labor market, for foreign exports, for consumption and for investment, which should be appended to the interregional model.



$d$  = total demand (net of regional exports);  
 $A = \{_{ij}a_s\}$  technical coefficients in region  $s$ ;  
 $B = \{_{i}b_{ts}\}$  regional trade coefficients: (4)  

$$\sum_t \{_{i}b_{ts}\} = 1 ;$$
 $Z = \{_{i}z_s\}$  correction coefficients for efficient  
 production in region  $s$ ;  
 $s, t, r$  = regions;  
 $i, j$  = sectors.

The supply equations for Tuscany ( $t$ ) and for the rest of Italy ( $r$ ) are:

$$\begin{aligned}
 (1+z_t)x_t &= b_{tt}d_t + b_{tr}d_r , \\
 (1+z_r)x_r &= b_{rt}d_t + b_{rr}d_r .
 \end{aligned}
 \tag{5}$$

The demand equations are:

$$\begin{aligned}
 d_t &= A_t x_t + g_t , \\
 d_r &= A_r x_r + g_r ,
 \end{aligned}
 \tag{6}$$

while the vector of trade balances is:

$$u = b_{tr}d_r = b_{rt}d_t . \tag{7}$$

At this stage, we note that foreign trade has received only scant attention and, particularly, that all foreign imports are exogenous as if they were all competitive. Clearly, the model should be more sophisticated from this point-of-view to allow a sensible analysis of a region such as Tuscany. Section 4 will be devoted to an improved treatment of foreign trade. Interregional trade will also be analyzed below in more detail.

In the present formulation of the model, we utilize a simplified treatment of shipments between regions. This is because of the severe limitation on statistical information available. Two basic assumption are made. The shipments of goods for consumption (both final and intermediate) and for investment are assumed

to show a common pattern. The supply pattern of region t to region r is the same for each production sector.

The resulting matrix B is then formed by diagonal blocks. This implies that for every sector i we have a share submatrix of four coefficients with unity column sums.

It would be interesting to check the robustness of the results with regards to this specification of the trading pattern, if the results of the survey for the direct table were already available. Although simple, this treatment of regional trade has some interesting properties.

By combining the demand and supply equations:

$$\begin{aligned} (1+z_t)x_t + b_{tt}m_t + b_{tr}m_r &= b_{tt}d_t + b_{tr}A_r x_r + b_{tr}f_r , \\ (1+z_r)x_r + b_{rr}m_r + b_{rt}m_t &= b_{rr}d_r + b_{rt}A_t x_t + b_{rt}f_t , \end{aligned} \tag{8}$$

one can observe that the last term of both equations implies (by the definition of  $f_t$  and  $f_r$ ) that a foreign export of one region can be sustained simply by an import from the other.

This is the case for imports from abroad. If we consider, for instance, the term  $b_{tr}m_r$  in the first equation, we can observe that if production in region t is discontinued (by an assumption of comparative advantages), the demand of region t can still be sustained by imports from region r if  $b_{tr}$  is not zero. This possibility could be very important if the model were implemented with data obtained from regional trade statistics. But this is not the case for the present version of the model. Besides, it is important to note that a bias arises in the arrangement of customs statistics, in which it cannot be ascertained whether a flow observed in region t is actually pertinent to another region r.

Furthermore, there is room for some improvements, to be used in Section 4, in at least two aspects. The hypothesis of pure competitiveness of foreign imports, for instance, can be removed with appropriate functions. There is, in equation (8) the possibility of a short circuit on foreign trade: the flow of imports  $b_{tt}m_t + b_{tr}m_r$  can produce exports abroad, which are included, by definition, in  $d_t$  and  $f_t$ . This is however a minor problem.

The causal structure of the model is shown in Figure 2.

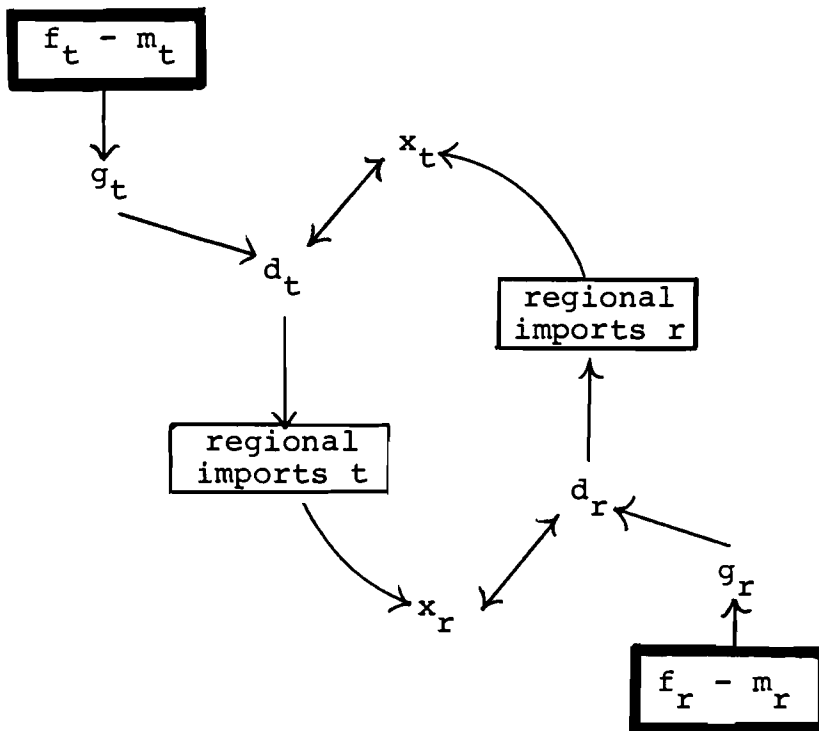

Figure 2. Causal structure of the simplest version of TIM 75 (t = Tuscany, r = the rest of Italy).

From Figure 2, it is now clear that for a given exogenous final demand and foreign trade vector and for a given or fixed trading pattern B, the model gives consistency between production and interregional shipments.

#### 4. THE TREATMENT OF FOREIGN TRADE WITHIN THE INTERREGIONAL INPUT-OUTPUT MODEL

If all foreign imports are in fact competitive, we are allowed to keep the corresponding value exogenous, and the solution for effective production is simply:

$$x = (I+Z-BA)^{-1} B(f-m) \quad . \quad (9)$$

Here we can observe that while the negative direct effect on the production of region t of a certain amount of competitive imports is given by  $(b_{tt}m_t + b_{tr}m_r)$ , its total negative effect is

$h_{tt}(b_{tt}m_t + b_{tr}m_r) + h_{tr}(b_{rt}n_t + b_{rr}m_r)$ , where  $h_{tt}$  is the upper left block of the partitioned inverse  $H = [I - (BA - Z)]^{-1}$  and  $h_{tr}$  is the upper right block. This kind of model can be used for forecasting purposes only if it is possible to know in advance the vector  $m$ , which is a part of the solution. This could be a problem if one does not have available a submodel with which to obtain a forecast for  $m$ , for a given path of the terms of trade, and for a given path of productive capacity.\*

Because (9) is the first solution of the model, it is necessary to consider the effects of hypothesis (3) on the existence of the inverse  $H$ . Normally, the diagonal matrix  $Z$  should have small figures in relation to those of the technical matrix  $A$  and, consequently, there should not be a violation of mathematical conditions for the existence of an inverse  $H$  with non-negative elements only.

For the sectors where there are significant secondary products ( $z_i$  is negative), the resulting diagonal element may be small when compared with the corresponding row elements.

In this case, the invertible matrix tends to have a less dominant positive principal diagonal and, thus, to have a less rapid convergence rate in the iterative solution, but should always have an inverse with non-negative elements. We note that the Leontief matrix obtained from the Tuscany and rest-of-Italy tables is reducible. This implies that some elements of the Leontief inverse are zero.

The pure competition hypothesis is not very realistic because several resources are produced neither in the region considered nor in the other regions and, therefore, have to be imported. The model with foreign complementary imports only is:

$$(I+Z)x = B(Ax+f) - MBx - NBq, \quad (10)$$

where  $M$  and  $N$  are diagonal matrices of coefficients and  $q$  is the final demand  $f$  net of exports abroad  $e$ .

---

\* When demand is higher than capacity, there will be more imports from abroad.

The solution is:

$$x = [I+Z-(I-M)BA]^{-1} [(I-N)Bf+NBe] \quad . \quad (11)$$

This model shows a higher degree of endogeneity even if the multipliers of the new inverse are smaller than those computed in (9). For a given vector  $x$  here we have actually smaller multipliers with a higher final demand. A more realistic solution is the mixed one where both competitive and complementary imports are present. Thus, the system of equations:

$$(I+Z)x + MBAx + NBq + Bm = BAx + Bf \quad ,$$

has the solution:

$$x = [I+Z-(I-M)BA]^{-1} [(I-N)Bf+NBe-Bm] \quad . \quad (12)$$

The degree of endogeneity is the same, but the final demand vector is reduced by the exogenous amount  $Bm$  which has to be forecasted by a side model.

It is useful to write the same model in an extended way. Some insights are gathered on the indirect linkages of Tuscany with the rest of the world:

$$\begin{aligned} (I+Z_t)x_t + M_t B_{tt} A_t x_t + N_t B_{tt} q_t + B_{tt} m_t + B_{tr} m_r \\ + M_t B_{tr} A_r x_r + N_t B_{tr} q_r = B_{tt} (A_t x_t + q_t) \\ + B_{tr} (A_r x_r + q_r) + B_{tt} e_t + B_{tr} e_r \quad . \end{aligned}$$

In this formulation, we find with the last two terms before the equal sign, the possibility that a good imported by Tuscany from abroad is simply sent to the rest of Italy. The last term of the equation implies instead that a good exported abroad from the rest of Italy is sustained by Tuscany's production. It is obvious that similar flows are present in the equation for the rest of Italy.

Furthermore, the same decomposition shows the absence of any short circuit in foreign trade, which seems to be present in the reduced form (12). The vector  $[(I-N)Bf + NBe - Bm]$  is indeed equal to  $(Bf - NBq - Bm)$  by the definition of  $q$  as a vector of final demand net of foreign exports and also equal to  $[(I-N)Bq + B(e-m)]$ . This means that the final demand component can be defined in three different ways.

## 5. TREATMENT OF REGIONAL TRADE

Also for the shipments between the two regions one must decide if it is better to consider them as competitive or as complementary. If we consider the low degree of self-sufficiency of the regional economic system, we should conclude that imports from the other region are more complementary than competitive. It does not make sense to postulate a real price competitiveness between regions, because the share of the regional market is so limited for the sector in which there is regional trade that a firm cannot face an indefinite price competition from other regions. We are then inclined to assume complementarity in regional trade. If full capacity is reached and demand is rigid, the most probable outcome will be--by a similar argument--an increase in imports (competitive in this case) from foreign countries.

If we are unable to distinguish the import content of intermediate consumption and of final demand and if we assume complementarity, we can relate regional imports simply to the level of production using a diagonal matrix of coefficients  $V$ . With this and by changing some definitions:

$V = \{ {}_r v_i \}$  regional trade coefficients (complementary);

$f$  = total final demand (internal demand plus exports abroad and plus regional exports);

$q = f - e$ ;

$d = Ax + f$  total demand;

we obtain the model:

$$x = [I + Z + V - (I-M)A]^{-1} [(I-N)q + (e-m)] \quad . \quad (13)$$

The causal structure of the model is shown in Figure 3. It highlights not only the tight interdependences between the two regions, but also the existence of indirect linkages between a region and the rest of the world.

Let us, for example, consider Tuscany: its foreign exports are linked to its regional imports, whereas a part of its foreign imports are linked to its regional exports.

If we admit a certain degree of substitutability between internal and external production, it is preferable to follow the hypothesis already made in the preceding paragraphs. In this case, interregional trade flows are dependent on total demand ( $d$  in this case is net of regional exports) and the solution is given by (12). The conclusion is that foreign and regional trade are treated with a kind of asymmetry, which should be clear from Table 2 (where  $q$  and  $d$  imply a different definition of  $f$ ).

Table 2. The treatment of foreign and regional trade.

	COMPLEMENTARY IMPORTS	COMPETITIVE IMPORTS
REGIONAL TRADE	$Vx$	$Bd$
FOREIGN TRADE	$MBx + NBq$	$m$ exogenous

The fact is that competitiveness of imports means substitution between the two possible locations of production. In an interregional input-output model, substitution between regions is possible using  $Bd$  (see system (5)), but substitution between countries is not possible because only one national production is considered and this is why  $m$  is exogenous.

We now focus attention on the estimation of trade flows between regions. This problem is common to all interregional models. In our case, there are only two regions; this is a very special situation and should therefore be simpler to handle. More precisely, the purpose of our analysis is to improve the estimate of flows between the two regions already obtained (Marliani 1981) and used in the application of system (12). This estimate

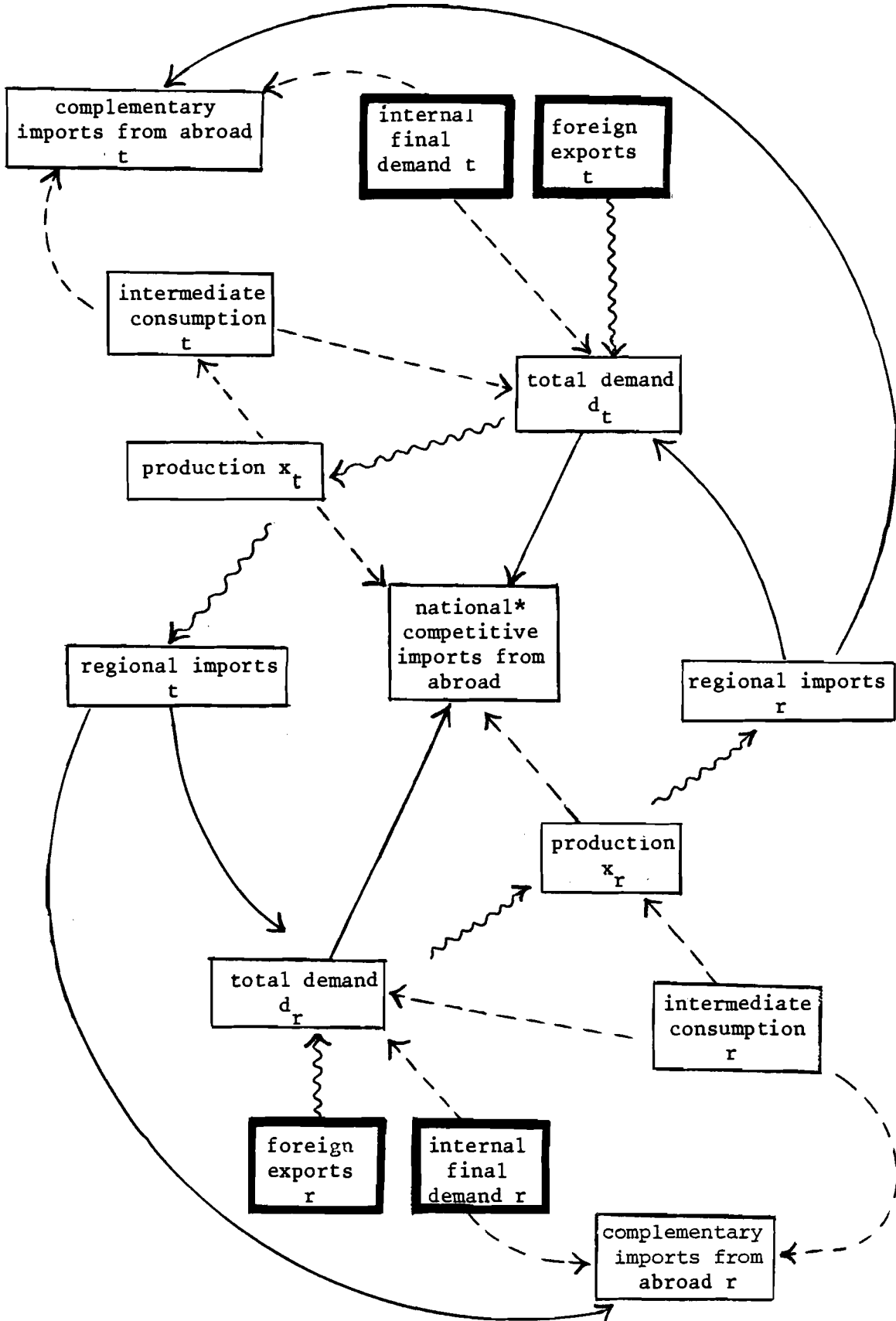

Figure 3. Causal structure of TIM when regional imports are complementary (  $t$  = Tuscany,  $r$  = the rest of Italy).  
\*(Foreign competitive imports depend, in this case, on the excess in demand over capacity.)



does not admit, by definition, crosshauling effects. Basically, it has been assumed that exports are equal to a surplus, exports and imports equal to a deficit balance.

Now, if we consider the basic system (5), we can immediately say that for a given  $x$  and  $d$  this assumption minimizes the interaction between the two regions. In order to grasp the problem better, let us consider one specific sector,  $i$ . The system will be

$$\left\{ \begin{array}{l} i^x_t = i^{b_{tt}} d_t + i^{b_{tr}} d_r \quad , \\ i^x_r = i^{b_{rt}} d_t + i^{b_{rr}} d_r \quad , \\ i^{b_{tt}} + i^{b_{rt}} \equiv i^{b_{tr}} + i^{b_{rr}} = 1 \quad . \end{array} \right. \quad (14)$$

If we ignore for a moment the estimate of IRPET, the unknowns are the trade coefficients  $i^B$ , with  $i^x$  and  $i^d$  as given.

The first two equations of (14) allow for a substitutability between Tuscany and the rest of Italy that can be used to define two transformation functions, while the third gives the constraints  $b_{tr} = 1 - b_{rr}$ .\*

$$\left\{ \begin{array}{l} b_{tt} = x_t/d_t - b_{tr} d_r/d_t \quad , \\ b_{rt} = x_r/d_t - b_{rr} d_r/d_t \quad , \\ b_{tr} = 1 - b_{rr} \quad . \end{array} \right. \quad (15)$$

These equations are represented in Figure 4, where the attainable area for the trade parameters is delimited by ABCDEO.

The two transformations (straight lines) are represented on the lateral planes. Their location is clearly related to the relative value of the two demands  $d_r/d_t$  and to their composition within national production.

---

\*The fourth constraint  $b_{tt} + b_{rt} = 1$  and the trade balance (7) are redundant. In the following we omit the  $i$ .

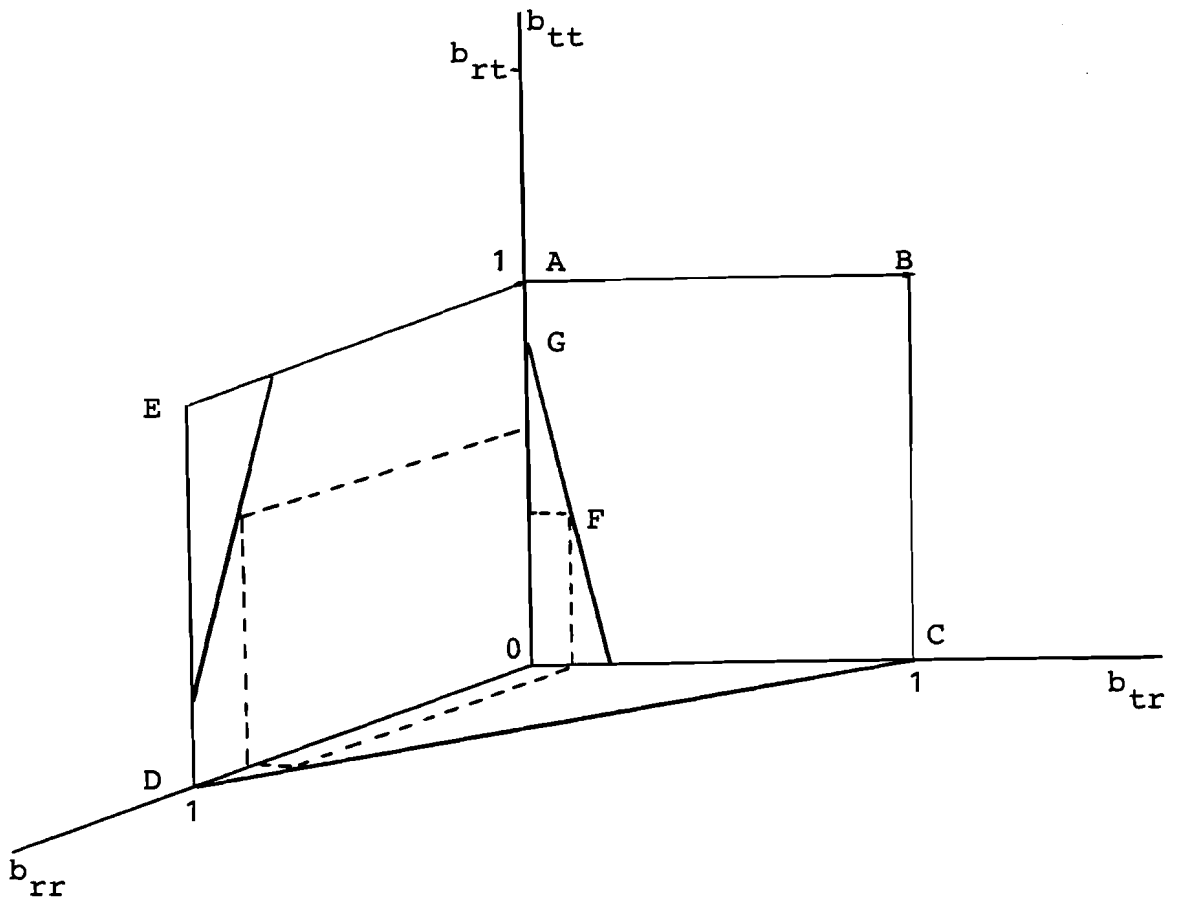

Figure 4. Parameter space for trade coefficients of a Chenery-Moses model with two regions ( $t =$  Tuscany,  $r =$  rest of Italy).

There is clearly a latitude of choice and with no information other than that on the trade balance, the parameters for every sector  $i$  cannot be determined.

If we are able to fix the existing degree of freedom (for instance, by choosing the point  $F$ ), the solution is immediately obtained along the dotted line. But there are many possibilities. IRPET has chosen one particular solution. It is characterized by the corner solution  $G$ , which is below  $A$  if Tuscany has a deficit balance and to the right of  $A$  (between  $A$  and  $B$ ) if Tuscany has a surplus. If we now repeat exactly the same procedure for a different year, we obtain two different lines of transformation. If they intercept the former lines inside the

admissible area OABCDE, we can assume stability for the trade parameters and solve the problem immediately.

If we reject this hypothesis or if the new lines do not intercept the old lines in the feasible area, we have four different possible situations (Figure 5).

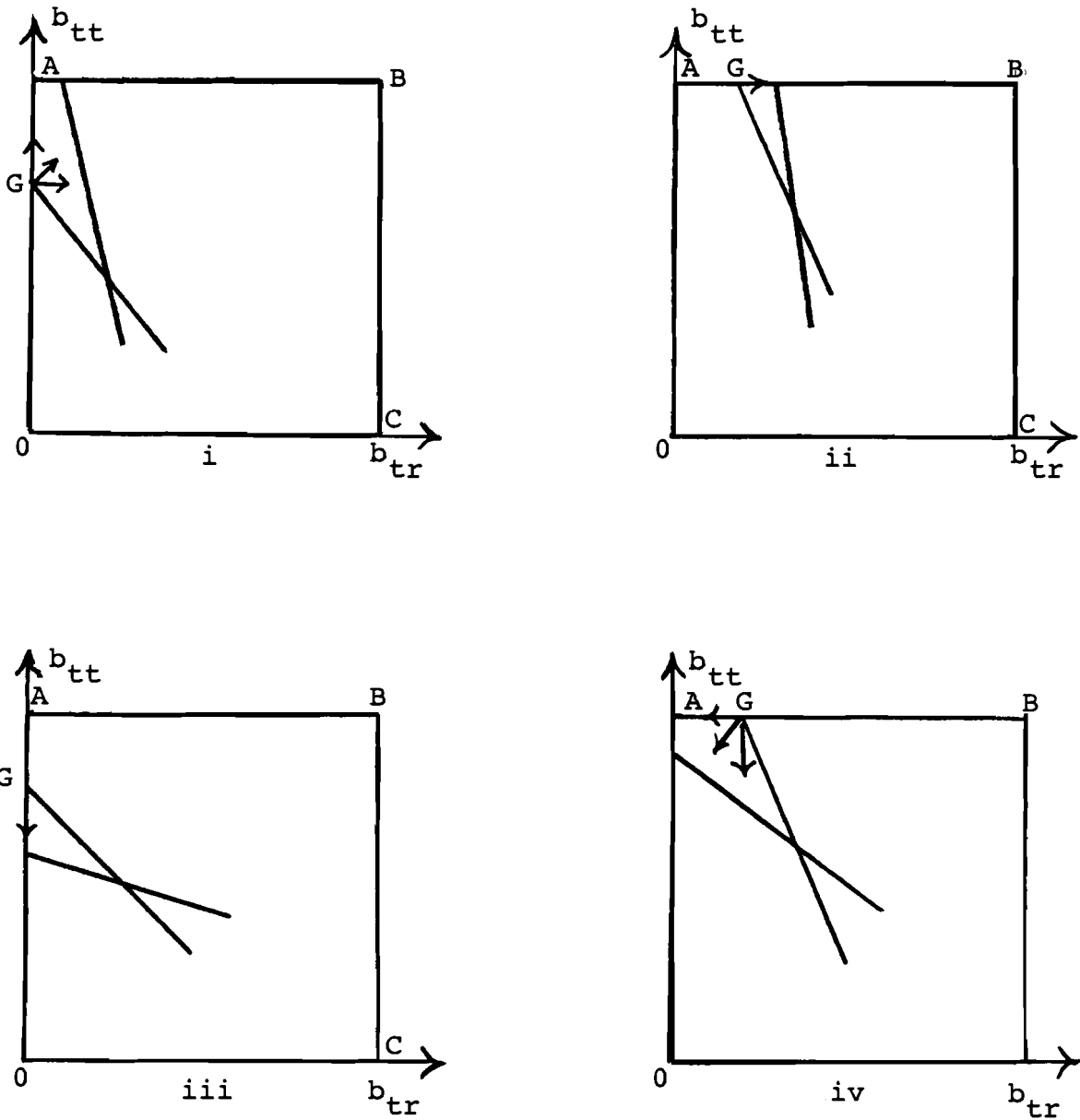

Figure 5. Shifting trade coefficients of a Chenery-Moses model with two regions.



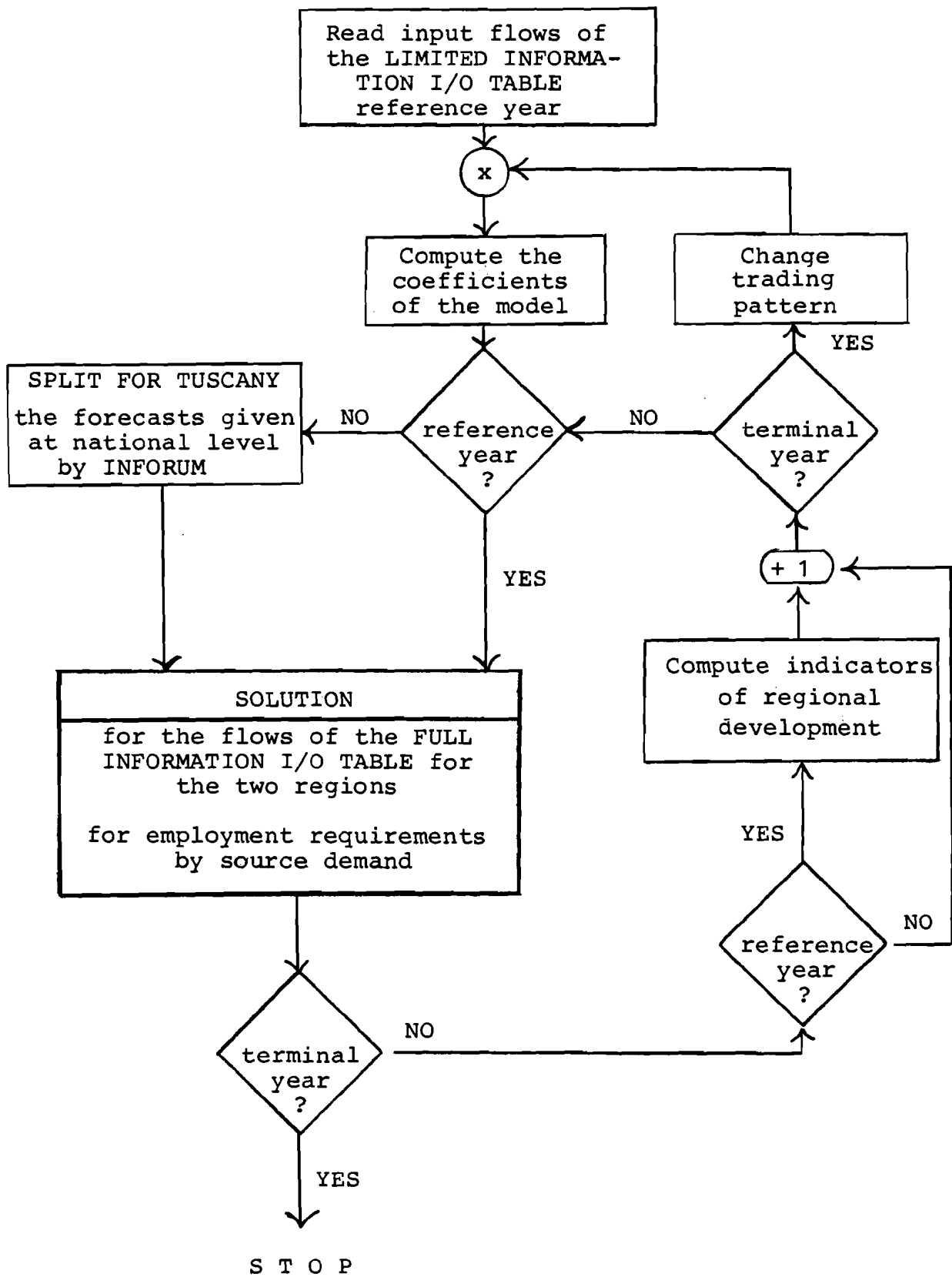

Figure 6. Flow chart of the preliminary analysis carried out using TIM 75.

Then follows a structural analysis of the degree of interdependence of the two regions. This is based upon indexes obtained from the upper block summing the matrices along the rows (Martelato 1980):

$$(I-M_r)B_{rt} [I+Z_t - (I-M_t)B_{tt}A_t]^{-1} ,$$

$$(I-M_t)B_{tr} [I+Z_r - (I-M_r)B_{rr}A_r]^{-1} .$$

The results show that the total index of dependence of Tuscany on the other region is almost 20 times that of the rest of Italy on Tuscany (see Table 4).

Table 4. Regional dependence by sector, 1975.

Sector		Tuscany upon rest of Italy	Rest of Italy upon Tuscany
Agriculture	1	0.519	0.
Coal and oil	2	0.988	0.
Other energy forms and water	3	0.002	0.004
Minerals	4	0.	0.047
Minerals, non-metal.	5	0.	0.019
Chemicals	6	0.158	0.
Metal products	7	0.	0.004
Machinery for industry, agr.	8	0.058	0.
Other machinery	9	0.011	0.
Electrical equipment	10	0.116	0.
Transport equipment	11	0.046	0.002
Meat	12	0.139	0.
Milk	13	0.070	0.
Other food products	14	0.	0.015
Beverages	15	0.	0.001
Tobacco	16	0.	0.
Textiles	17	0.	0.013
Footwear	18	0.013	0.
Wood and Furniture	19	0.	0.015
Paper and paper products	20	0.145	0.
Rubber and rubber products	21	0.173	0.
Other manufactures	22	0.002	0.
Construction	23	0.	0.
Commerce	24	0.053	0.003
Hotels	25	0.	0.
Transport	26	0.035	0.013
Communications	27	0.	0.002
Credit and insurance	28	0.112	0.
Housing	29	0.	0.
Other marketable services	30	0.054	0.001
Non-marketable services	31	0.	0.
T O T A L		2.694	0.139

At this stage, while maintaining the coefficients constant, forecasts are performed for given values of  $f$  (that is, for consumption, investment, and foreign exports).

Another exercise is to keep everything constant at the level of 1975 except for final demand in Tuscany, which is obtained from the table for 1977. In this way, it is possible to assess--for every component of the exogenous vector--its effect on the level of employment in Tuscany and in the rest of Italy and, hence, the regional spillover of the global demand effect of Tuscany, valued at current prices.

Let us consider the national employment effect first. For a given 1% increase in private consumption, public consumption, investments and foreign exports of Tuscany, we get an increase in Italy of 3.2%, 3.5%, 4.8%, and 5.8%, respectively. On this basis, we should conclude that the most effective demand component is foreign exports.

Let us, however, consider the results in terms of elasticity (Table 5).

Table 5. Elasticities of employment increase with respect to four categories of final demand in Tuscany only (1977).

Final demand	Employment increase
Private consumption	0.93
Public consumption	0.98
Investment	0.87
Foreign exports	0.78

We may note that the elasticity of public consumption is the highest (which is not surprising), but also that the elasticity of foreign exports is the lowest (which is surprising).

The explanation could be that the leakage is stronger for export-oriented sectors in Tuscany. We observe that the elasticities are below unity, which means that the positive effect of the increased production in the rest of Italy is not sufficiently strong to counterbalance the spillover effect of Tuscany in favor of the rest of Italy.

Now let us move to a more traditional exercise related to evaluating the impact of an increase (1978) on the final demand in both regions at constant prices (1975).

The first outcome of the construction of the Tuscany direct input-output table for 1978 is the availability of final demand. Having obtained comparable data for Italy from national accounting statistics, and having deflated the flows, we computed the set of elasticities shown in Table 6.

Table 6. Elasticities of employment increase with respect to four categories of final demand, 1978.

Final demand	Employment increase	
	Tuscany	Rest of Italy
Private consumption	1.68	2.40
Public consumption	1.00	0.99
Investment	0.82	1.16
Foreign exports	0.95	1.09

With respect to the preceding simulation, the increase in the final demand of the rest of Italy allows us to compute the elasticities for this region and to adjust the elasticities of Tuscany. These elasticities depend in this case both on the direct and the indirect effects. The first is that produced locally by the increase in local final demand, whereas the second is generated by the feedback given by interregional trade.

The difference between the two elasticities is strong only in two cases: private consumption, and investment. In the remaining two cases, the relative increase in the level of employment is very close to the relative increase in the final demand component.

For private consumption and investment, the demand effects seem to favor the rest of Italy. This is clearly a result of the lower self-sufficiency of Tuscany, especially in light industry. In both regions, finally, the employment effect of private consumption is twice that of investment, which is to be expected.



## 7. FUTURE DEVELOPMENT OF TIM

In the first section, the relevance of analyzing the trade relations of a region such as Tuscany, rather than analyzing the factor mobility of price relations, has been stressed. The hypothesis has been that the level of internal economic activity in a very open region is necessarily strongly influenced by its trade relations.

One may wonder whether the results discussed in the preceding section are sufficiently clear and convincing to validate our hypothesis. Certainly, we have to take account of this, which means that we have to be prepared to reject the hypothesis. There is another argument in favor of an analysis focused on trade relations. It is that the fundamental task of TIM and other models developed within the Tuscany case study is to aid in a sufficiently comprehensive assessment of the economic impact of national policies at the regional level. It is doubtful whether such an assessment could indeed be made without considering the interindustrial and interregional relations of that region. Without these dimensions, a model cannot give a correct estimate of the income or employment multipliers and regional spillovers.

It should be clear that TIM alone cannot comprehensively evaluate the regional effects. It constitutes the starting point and can be considered as the core of a system of models. In this way, we are induced to state some possible future developments of the current version of TIM having as a kernel the interregional trade pattern.

In so doing, we find at least three different avenues of future research. These future developments will imply solution procedures that differ from those that are currently used.

A. In its present state, TIM is a linear static recursive system of equations of small dimensions. Because of the limitations of the data base, the treatment of trade relations is very simple both for regional and foreign relations. It is solved in a way that tries to take advantage of its intrinsic recursiveness. Firstly, the solution for production is obtained by straight inversion, then the vectors of

employment, regional imports, and foreign imports are computed for given parameters and vectors of exogenous demand.

- B. One way to improve the features of the model could be a more sophisticated treatment of trade: differentiation of trade patterns for intermediate consumption and final use, and within this, for final consumption and investment. For foreign trade it would also be useful to separate competitive imports from complementary imports. This would imply a richer data base (direct table for 1978), but the solution procedure described under A would still remain valid. These improvements are internal improvements to a model that can give only short-term forecasts.
- C. A second way would be to relax the assumption of parameter stability, in order to make the model capable of giving long-range projections. Aside from the obvious possibility of changing the technical coefficients, particular attention should be given to the stability hypothesis for the regional trade coefficients, because of their high degree of instability and because of the possibility of obtaining endogenously a better estimate of regional trade. Since the method of doing this has been presented elsewhere (Martellato 1981b), we need only mention here that consistency of equilibrium between the production allocation and trade patterns has to be reached. The model becomes non-linear because some of its parameters are simultaneously determined in the course of the solution of the production level.

There are essentially four possibilities:

- to break the simultaneity by specifying exogenously a trend for the trade parameter using employment data or lagged production data by sector and region;
- to assume optimization behavior for the economic agents and to minimize total transport costs;
- to assume conservative behavior of agents and to minimize the information given by the new pattern of production and trade in relation to the old patterns for a given exogenous demand;
- to use an iterative technique of power expansion of the inverse of the current coefficient matrix of the model.

D. The third avenue for possible future developments is that of increasing the scope of the model itself. This can imply an increased consistency within TIM as it currently stands. This can be done by transferring--where possible--some of the current final demand components from the exogenous vector to the invertible matrix: consumption, investment, exports abroad. Alternatively, it can require the implementation of satellite models to be appended to TIM. This can be done for consumption, investment, and foreign exports, but also for the demographic-migration component, housing investment, energy and environmental aspects, water demand, financial markets, public finance. An alternative would be to build a satellite model for investment (the same as for exports and consumption) aiming to find the share of Tuscany within a forecasted national total. This kind of model has already been used for some regions in Italy (Martellato, 1980).

All these possibilities imply that the model will become much larger. A more appropriate solution procedure is therefore in order, because the model would stand as a large linear model with many equations and a sparse matrix of coefficients.

One should try to solve it by inversion using an appropriate routine for sparse matrix inversion or try to take advantage of the causal structure of the matrix. Thus, one could solve part of the model recursively and then use a Gauss-Seidel iteration for the simultaneous part of it.

E. A special case of point D occurs when the investment is made endogenous within the input-output model via a matrix of capital coefficients (following the work of Leontief). In this case, there are two problems. The first is the estimation of these coefficients, the second is the solution procedure, which requires special attention. The model becomes dynamic and its structural matrix is no longer invertible because the capital stock coefficients matrix is typically singular.

While the second problem can be solved in several ways, the first is a challenging one without a direct measure of the stock of capital, and the potential output by sector. This problem, however, can be tackled with procedures advanced, for example, by Andersson and Martellato (1980). Why should we challenge the difficulties of the implementation of a bi-regional dynamic input-output model? Or, in other words, why do we consider a static model to be unsatisfactory and try to obtain its dynamic counterpart?

The static input-output model clearly provides a powerful and flexible approach more suited to regional economic problems than a more aggregated technique. However, there are at least three arguments in favor of the dynamic input-output model.

The first is the fact that the multipliers of a static model do not provide any information about the time path of the economic system, they simply give the impact of the first period and disregard the lagged response of the system.

The second argument is related to the short-term characteristics of static input-output analysis. Because regional growth disparities are always strong and often related to business cycles, and because regions inevitably show deep interactions, we should also pay attention to the regional growth linkages. However, a static model cannot trace the dynamic (or long-run) feedbacks.

Finally, with a static model, we are forced to give a regional and sectoral breakdown only of the trade flows generated by intermediate consumption, disregarding those linked to capital formation. It follows that only with a dynamic input-output model can we obtain unbiased interregional multipliers.

## REFERENCES

- Andersson, Å.E. and D. Martellato. 1980. Estimation of Parameters of Dynamic Input-Output Models with Limited Information. WP-80-118. Laxenburg, Austria: International Institute for Applied Systems Analysis.
- Cavalieri, A. 1980. Development paths and placement within the international and intranational and national context: the Tuscany case. Paper presented at the First Italian Regional Science Conference, Rome.
- Cavalieri, A. 1981. International Trade Linkages in Interregional I/O Economic Modeling: The Model for the Tuscany Case Study. WP-81-150. Laxenburg, Austria: International Institute for Applied Systems Analysis.
- Lundqvist, L. 1981. Multisectoral and multiregional analysis of a small open economy: the Swedish case. Paper presented at the International Conference on "Structural Economic Analysis and Planning in Time and Space", Umeå, Sweden, June 22-26.
- Marliani, G. 1981. La matrice toscana del 1977: alcune verifiche statistiche sulle ipotesi di costruzione e sui metodi di stima. Florence: IRPET.
- Martellato, D. 1981a. Structural analysis with an updated interregional input-output model for Italy, 1977. Ricerche Economiche 35 (1,2).
- Martellato, D. 1981b. Consistency and feasibility in interregional input-output projections. Paper presented at the International Conference on "Structural Economic Analysis and Planning in Time and Space", Umeå, Sweden, June 22-26.
- Snickars, F. 1981. Interregional and International Linkages in Multiregional Economic Models. WP-81-00. Laxenburg, Austria: International Institute for Applied Systems Analysis.
- Snickars, F. and A. Granholm. 1981. A Multiregional Planning and Forecasting Model with Special Regard to the Public Sector. WP-81-00. Laxenburg, Austria: International Institute for Applied Systems Analysis.